

MATRIX

**T5X-07 TREADMILL
SERVICE MANUAL**

TABLE OF CONTENTS

CHAPTER 1: SERIAL NUMBER LOCATION	1
CHAPTER 2: IMPORTANT SAFETY INSTRUCTIONS	
2.1 Before Getting Started	2
2.2 Read and Save These Instructions	3
2.3 Electrical Requirements	4
CHAPTER 3: PREVENTATIVE MAINTENANCE	
3.1 Recommended Cleaning Tips	5
3.2 Check for Damaged Parts	5
3.3 Care and Maintenance Instructions	6
3.4 Auto Calibration Procedure	7
3.5 Adjusting the Running Belt	7
CHAPTER 4: USING THE CONSOLE AND PROGRAM DESCRIPTION	
4.1 Console Description	8
4.2 Manual Workout Operation	9
4.3 Operating Level Based Programs	9
4.4 Heart Rate Control Workout Operation	10
4.5 Fitness Test Workout Operation	10
CHAPTER 5: MANAGER MODE	
5.1 Using Manager Mode	12
5.2 Manager Mode Overview	12
CHAPTER 6: ENGINEERING MODE	
6.1 Using Engineering Mode	13
6.2 Engineering Mode Overview	13
CHAPTER 7: SERVICE MODE:	
7.1 Using Service Mode	14
7.2 Service Mode Overview	14
CHAPTER 8: TROUBLESHOOTING	
8.1 Electrical Diagram	15
8.2 Motor Control Board (MCB) LED Instructions	18
8.3 MCB Wiring	19
8.4 0140 / 01A0 / 01A2 Error Troubleshooting	20
8.5 01A3 Error Troubleshooting	20
8.6 01A8 / 02B6 / 02B7 / 02B8 Error Troubleshooting	21
8.7 01AD Error Troubleshooting	21
8.8 02AD Error Troubleshooting	22
8.9 02B2 Error Troubleshooting	22
8.10 02B9 / 02BA / 02BD Error Troubleshooting	23
8.11 04A0 Error Troubleshooting	23
8.12 Troubleshooting - No Power To The Console	24
8.13 Troubleshooting - Heart Rate Issues	25
8.14 Troubleshooting - Speed Shown is Higher than Belt Speed	26
CHAPTER 9: PART REPLACEMENT GUIDE	
9.1 Motor Cover and Lower Shroud Removal	27
9.2 Rear Roller Replacement	28
9.3 Deck Removal	29
9.4 Deck Cushion Replacement	30
9.5 Front Roller Replacement	31
9.6 Running Belt Removal	32
9.7 Side Rail Replacement	33
9.8 Motor Control Board (MCB) Replacement	34
9.9 Motor Replacement	35
9.10 Drive Belt Replacement	36
9.11 Incline Motor Replacement	38
9.12 Console Replacement	39
9.13 Console Mast Arm Replacement	40
9.14 Console Cable Replacement	43

TABLE OF CONTENTS

9.15	Handlebar Service.....	45
9.16	Emergency Stop Switch Replacement.....	46
9.17	Heart Rate Board Replacement	47
9.18	Blower Motor Replacement	48
9.19	Overlay Replacement.....	49

CHAPTER 10: TREADMILL SPECIFICATIONS AND ASSEMBLY GUIDE

10.1	Treadmill Specifications	51
10.2	Fasteners and Assembly Tools	52
10.3	Assembly Instructions	53
10.4	Leveling the Unit	57

CHAPTER 11: SOFTWARE UPGRADE INSTRUCTIONS

11.1	Software Upgrade Instructions.....	58
------	------------------------------------	----

1.1 SERIAL NUMBER LOCATION

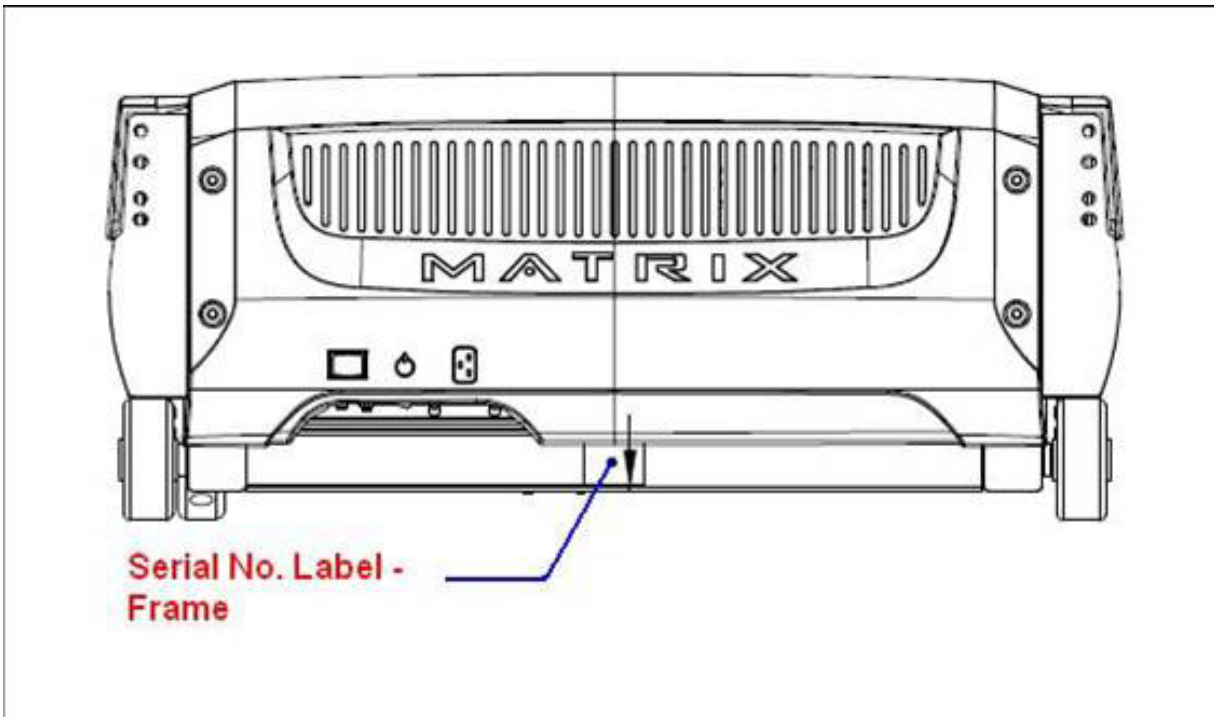

CHAPTER 2: IMPORTANT SAFETY INFORMATION

2.1 BEFORE GETTING STARTED

This treadmill is intended for commercial use. To ensure your safety and protect the equipment, read all instructions before operating the Matrix Treadmill.

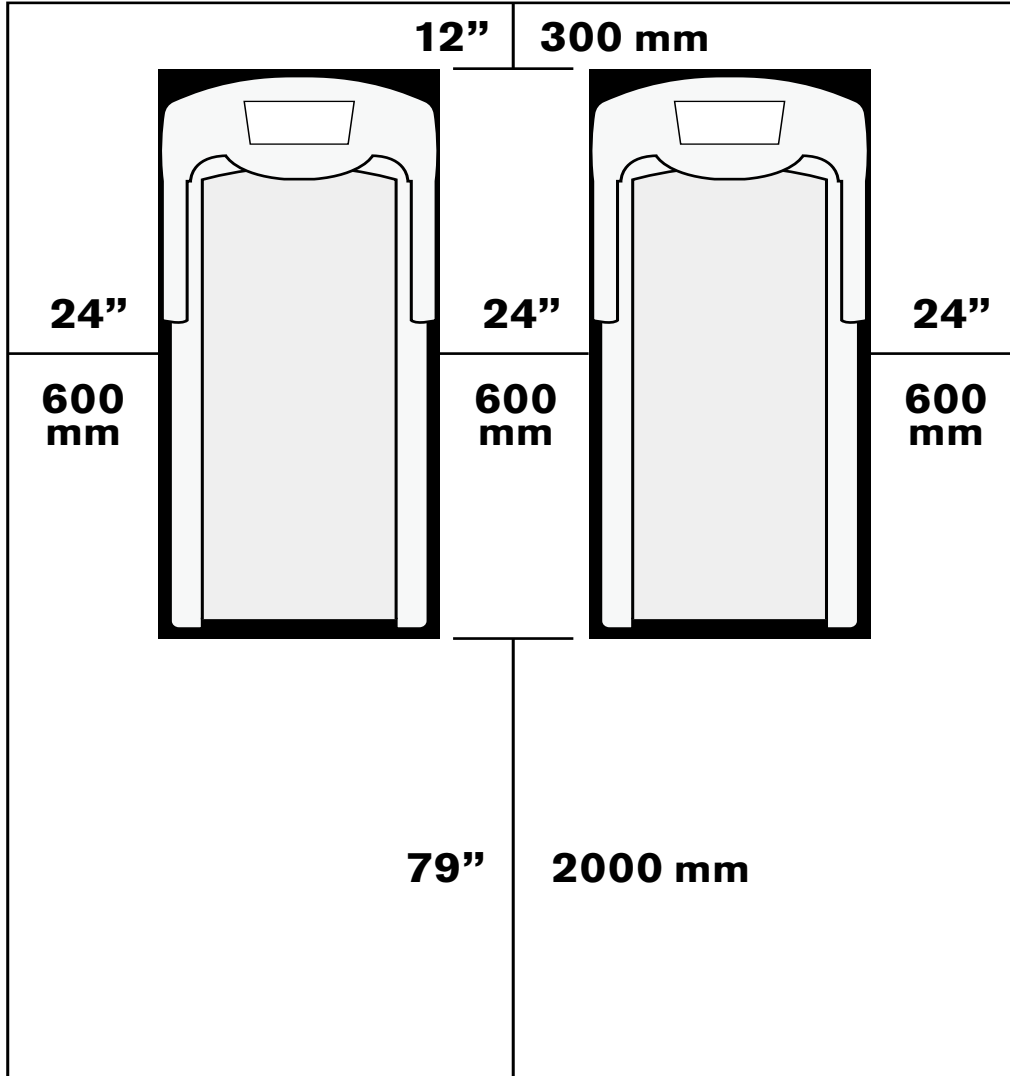

Place the treadmill on a level and stable surface away from direct sunlight. The intense UV light can cause discoloration on the plastics. Locate your treadmill in an area with cool temperatures and low humidity. Please leave a clear zone behind the treadmill that is at least the width of the treadmill and at least 79" (2000 mm) long. This zone must be clear of any obstruction and provide the user a clear exit path from the machine. For ease of access, there should be an accessible space on both sides of the treadmill of at least 24" (600 mm) to allow a user access to the treadmill from either side. Do not place the treadmill in any area that will block any vent or air openings. The treadmill should not be located in a garage, covered patio, near water or outdoors.

2.2 READ AND SAVE THESE INSTRUCTIONS

This treadmill is intended for commercial use. To ensure your safety and protect the equipment, read all instructions before operating the MATRIX T5x-04 treadmill.

When using an electrical product, basic precautions should always be followed including the following:

DANGER: To reduce the risk of electric shock: Always unplug this equipment from the electrical outlet immediately after using and before cleaning.

WARNING: To reduce the risk of burns, fire, electrical shock or injury to persons that may be associated with using this product.

An appliance should never be left unattended when plugged in. Unplug from the outlet when not in use and before putting on or taking off parts.

This product must be used for its intended purpose described in this service manual. Do not use other attachments that are not recommended by the manufacturer. Attachments may cause injury.

To prevent electrical shock, never drop or insert any object into any opening.

Do not remove the console covers. Service should only be done by an authorized service technician.

Never operate the treadmill with the air opening blocked. Keep the air opening clear, free of lint and hair.

Never operate product if it has a damaged cord or plug, if it is working improperly, if it has been damaged, or immersed in water.

Do not carry this unit by its supply cord or use the cord as a handle.

Keep any power cord away from heated surfaces.

Close supervision is necessary when the treadmill is used by or near children or disabled persons.

Do not use outdoors.

Do not operate where aerosol (spray) products are being used or when oxygen is being administered.

To disconnect, turn all controls to the off position, then remove plug from the outlet.

Connect this treadmill to properly grounded outlets only.

CAUTION: If you experience chest pain, nausea, dizziness or shortness of breath, STOP exercising immediately and consult a physician before continuing.

- Do not use the equipment in any way other than designed or intended by the manufacturer. It is imperative that all Matrix Fitness System's equipment is used properly to avoid injury.
- Keep hands and feet clear of moving parts at all times to avoid injury.
- Unsupervised children must be kept away from this equipment.
- Do not wear loose clothing while on equipment.

CHAPTER 2: IMPORTANT SAFETY INFORMATION

2.3 ELECTRICAL REQUIREMENTS

For your safety and to ensure good treadmill performance, the ground on this circuit must be non-looped. Please refer to NEC articles 210-21 and 210-23. Your treadmill is provided with a power cord with a plug listed below and requires the listed outlet. Any alterations of this power cord could void all warranties of this product..

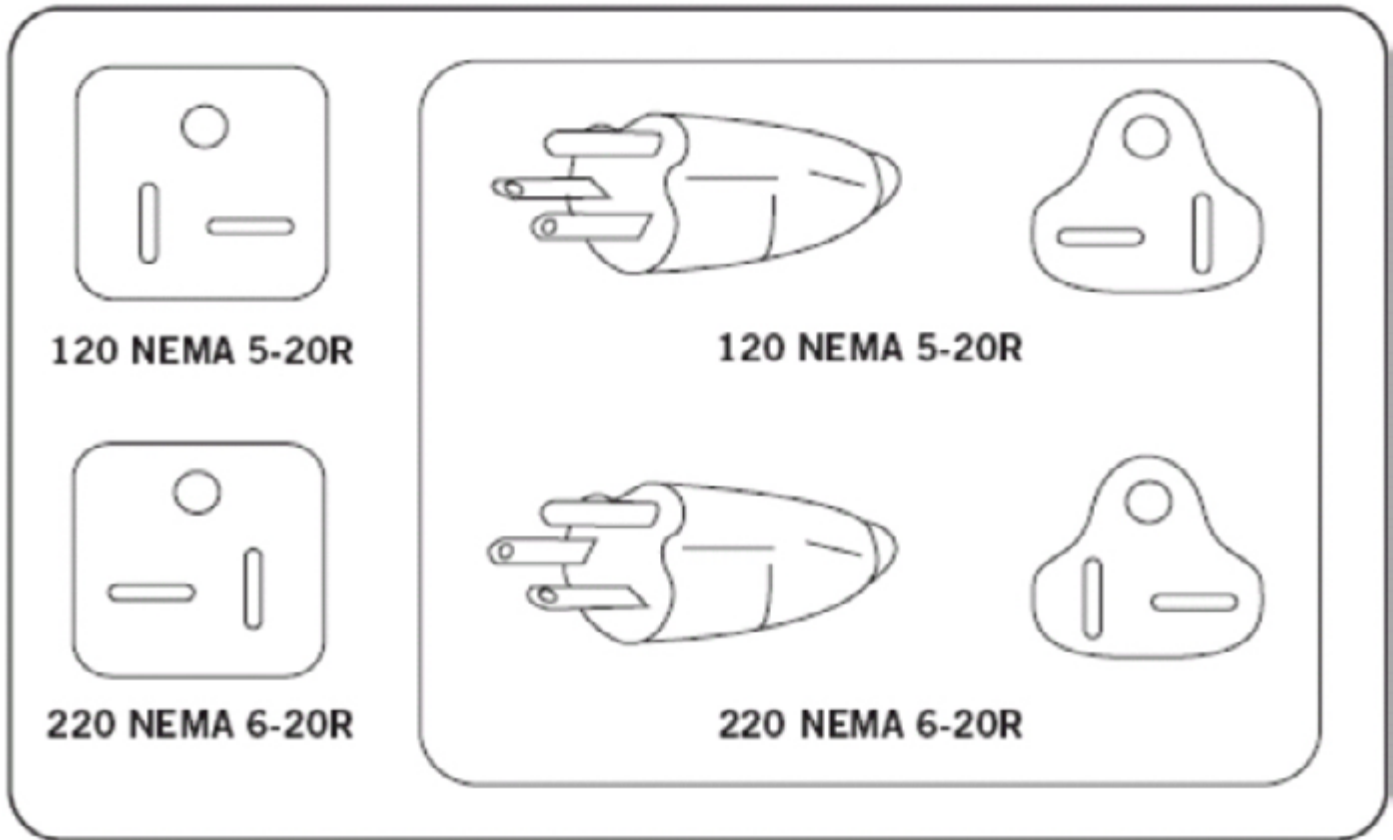

MATRIX DEDICATED CIRCUIT/ELECTRICAL REQUIREMENT INFO

All Matrix treadmills require the use of a 20 amp "dedicated circuit" with a non-looped (isolated) neutral / ground for the power requirement. Quite simply this means that each outlet you plug your treadmill into should not have anything else running on that same circuit. The easiest way to verify this is to locate the main circuit breaker box, and turn off the breaker(s) one at a time. Once a breaker has been turned off, the only thing that should not have power to it is the treadmill. No lamps, vending machines, fans, sound systems, or any other item should lose power when you perform this test.

Non-looped (isolated) neutral / grounding means that each circuit must have an individual neutral / ground connection coming from it, and terminating at an approved earth ground. You cannot "jumper" a single neutral / ground from one circuit to the next.

In addition to the dedicated circuit requirement, the proper gauge wire must be used from the circuit breaker box, to each outlet that will have the maximum number of units running off of it. If the distance from the circuit breaker box, to each outlet, is 100 feet or less, then 12 gauge wire may be used. For any distance greater than 100 feet from the circuit breaker box to the outlet, 10 gauge wire must be used.

3.1 RECOMMENDED CLEANING TIPS

Preventative maintenance and daily cleaning will prolong the life and look of your MATRIX T5x-04 Treadmill.

Please read and follow these tips.

- Position the equipment away from direct sunlight. The intense UV light can cause discoloration on plastics.
- Locate your equipment in an area with cool temperatures and low humidity.
- Clean with a soft 100% cotton cloth.
- Clean with soap and water or other non-ammonia based all purpose cleaners.
- Wipe foot rails, console, heart rate grips, and handlebars clean after each use.
- Do not pour liquids directly onto your equipment. This can cause damage to the equipment and in some cases electrocution.
- Check running belt for proper tension and routing.
- Adjust leveling feet when equipment wobbles or rocks.
- Maintain a clean area around equipment, free from dust and dirt.

3.2 CHECK FOR DAMAGED PARTS

DO NOT use any equipment that is damaged or has worn or broken parts. Use only replacement parts supplied by Matrix Fitness Systems.

MAINTAIN LABELS AND NAMEPLATES. Do not remove labels for any reason. They contain important information. If unreadable or missing, contact Matrix Fitness Systems for a replacement at 866-693-4863 or www.matrixfitness.com.

MAINTAIN ALL EQUIPMENT. Preventative maintenance is the key to smoothly operating equipment. Equipment needs to be inspected at regular intervals. Defective components must be kept out of use until they are repaired. Ensure that any person(s) making adjustments or performing maintenance or repair of any kind is qualified to do so. Matrix Fitness Systems will provide service and maintenance training at our corporate facility upon request or in the field if proper arrangements are made.

CHAPTER 3: PREVENTATIVE MAINTENANCE

3.3 CARE AND MAINTENANCE INSTRUCTIONS

In order to maximize life span, and minimize down time, all Matrix Fitness System's equipment requires regular cleaning, and maintenance items performed on a scheduled basis. This section contains detailed instructions on how to perform these items, the frequency of which they should be done, and a check list to sign off on each time service is completed for a specific machine. Some basic tools and supplies will be necessary to perform these tasks which include (but may not be limited to):

- * Metric Allen wrenches
- * #2 Phillips head screwdriver
- * Adjustable wrench
- * Torque wrench (capability to read foot lbs and inch lbs)
- * Lint free cleaning cloths
- * Teflon based spray lubricant such as "Super Lube" or other Matrix approved products.
- * Mild water soluble detergent such as "Simple Green" or other Matrix approved products
- * Vacuum cleaner with an extendable hose and crevasse tool attachment.

Please find the worksheet sample for our equipment provided in this manual and make copies as needed, keeping them up to date as required service / maintenance items are performed. It is critical that you also log the accumulated amount of miles or running hours on the equipment each time service or maintenance is performed.

You may periodically see addendums to this document, as the Matrix Technical Support Team identifies items that require specific attention, the latest version will always be available on the Matrix web site at www.matrixfitness.com.

DAILY MAINTENANCE ITEMS

- 1) Clean the entire machine using water and mild detergent such as "Simple Green", or other Matrix approved solutions (cleaning agents MUST be alcohol and ammonia free).
- 2) Check the emergency stop button and cord for proper operation.

MONTHLY MAINTENANCE ITEMS

- 1) Inspect the power cord for damage, inspect hand grip areas, and inspect the emergency stop button and cord for proper operation.
- 2) Check the running belt for proper tension, adjust as needed.

QUARTERLY MAINTENANCE ITEMS

- 1) Remove the front plastic cover, and vacuum the motor area of machine. Be careful when working around the MCB not to bump any wires or connections loose.
- 2) Check the drive belt for visible wear, ie, cracking, tears, etc. The belt should be replaced if there are any visible signs of damage. Proper alignment of the pulley / tensioner should be verified at this time as well.
- 3) Remove the plastic shroud at the front of the machine. Start the unit and raise incline settings to maximum height. Turn the power switch off at the front of the machine to prevent it from lowering accidentally. Lubricate incline motor Acme screw (Matrix recommends Super Lube brand grease with PTFE additive).

BI-ANNUAL MAINTENANCE ITEMS

- 1) Remove wax build up from the front and rear rollers of the machine.
- 2) Inspect the underside of the running belt for damage, check for cracking or glazed surfaces.
- 3) If the belt has damage or wear to it that warrants replacement, note that the running deck must also be flipped when a new belt is installed. If the deck has previously been flipped and no longer has an unused side available, it needs to be replaced when the new belt is installed. A new belt must ALWAYS be installed to run on a new deck surface in order to maximize the lifespan of both items.
- 4) During normal operating conditions, the running belt replacement and deck service should be done every 25,000 miles.

3.4 AUTO CALIBRATION INSTRUCTIONS

Run Auto Calibration to calibrate incline after assembly and after replacing any electronic component.

AUTO CALIBRATION PROCEDURE:

- 1) Press and hold the INCLINE DOWN and SPEED DOWN keys for three seconds until Manager Mode appears on the middle LED display.
- 2) Press any UP arrow key and Engineering Mode will appear on the display.
- 3) Press ENTER once Engineering Mode is displayed.
- 4) Scroll between programs in the Engineering Mode using any UP or DOWN arrow key until Auto Calibration appears on the middle LED display.
- 5) Press ENTER once Auto Calibration is displayed., you should not be standing on the running belt.
- 6) After completion, the display will state whether the Auto Calibration passed or failed.

3.5 ADJUSTING THE RUNNING BELT

After placing the treadmill in the position it will be used, the belt must be checked for proper tension and centering. The belt may need to be adjusted after the first 2 hours of use. Temperature, humidity, and use cause the belt to stretch at different rates. If the belt starts to slip when a user is on it, be sure to follow the directions below.

STEP 1: Locate the two hex head bolts on the rear of the treadmill. The bolts are located at each end of the frame at the back of the treadmill. These bolts adjust the rear roller. Do not adjust until the treadmill is on. This will prevent over tightening of one side.

STEP 2: The belt should have equal distance on either side between the frame. If the belt is touching one side, do not start the treadmill. Turn the bolts counter clockwise approximately one full turn on each side. Manually center the belt by pushing the belt from side to side. Tighten the bolts the same amount as when the user loosened them, approximately one full turn. Inspect the belt for damage.

STEP 3: While the treadmill is running at 3 mph, observe the belt position. If it is moving to the right, tighten the right bolt by turning it clockwise 1/4 turn, and loosen the left bolt 1/4 turn. If it is moving to the left, tighten the left bolt by turning it clockwise 1/4 turn and loosen the right 1/4 turn. Repeat Step 3 until the belt remains centered for several minutes.

STEP 4: Check the tension of the belt. The belt should be very snug. When a person walks or runs on the belt, it should not hesitate or slip. If this occurs, tighten the belt by turning both bolts clockwise 1/4 turn. Repeat if necessary.

4.1 CONSOLE DESCRIPTION

The Matrix T5x-07 Treadmill is inspected before it is packaged. It is shipped in four pieces: the base, the upright console supports, the handlebar, and the console. Carefully unpack the unit and dispose of the box material.



WORKOUT KEYS: Simple program view and selection buttons. Press the Fitness Test button to cycle through available tests.

QUICK START / GO: One touch Start and Quick Start.

ENTER: To confirm each program setting.

UP / DOWN INCLINE: Easy information and incline selection.

UP / DOWN SPEED: Easy information and speed selection.

UP / DOWN TIME: Easy information and time adjustment.

EMERGENCY STOP / IMMOBILIZATION: To stop all functions and immobilize the unit. The emergency stop on this treadmill must be returned to its original position in order to allow normal operation of the unit.

STOP: Ends workout and shows workout summary data.

PAUSE: Pauses workout. Pause duration can be set in Manager Mode.

NUMBER KEYPAD: Workout data input for workout setup. Speed adjustment during workout.

COOL DOWN: Puts treadmill into Cool Down mode. Cool Down time is dependent on the length of the workout. Workouts 19 minutes and shorter will have a cool down length of 2 minutes. Workouts 20 minutes and longer will have a cool down length of 5 minutes.

FAN: Allows for fan speed selection (fan has 3 operating speeds).

Language: Select Language.

4.2 MANUAL WORKOUT OPERATION

QUICK START OPERATION

Press the GO or QUICK START button(s) and the treadmill will enter into a manual mode of operation. All energy expenditure values will be calculated using the default weight measurement.

MANUAL WORKOUT OPERATION

Manual is a workout that allows you to manually adjust the speed and incline values at anytime. The manual workout also contains a setup screen which allows you to input your weight to help calculate a more accurate caloric burn rate.

To enter into this Manual Workout:

- 1) Choose MANUAL WORKOUT by selecting the manual workout button and press ENTER.
- 2) Enter the desired workout length using the ARROW KEYS or the NUMBER KEYPAD and press ENTER.
- 3) Enter user weight (user weight is used to calculate the caloric expenditure value-providing an accurate weight helps to ensure an accurate caloric expenditure rating for each user) using the ARROW KEYS or the NUMBER KEYPAD and press ENTER.
- 4) Enter the desired initial incline value using the ARROW KEYS or the NUMBER KEYPAD and press ENTER.
- 5) Enter the desired start speed using the ARROW KEYS or the NUMBER KEYPAD and press ENTER.
- 6) Press GO or QUICK START to begin workout.

4.3 OPERATING LEVEL BASED PROGRAMS

Your Matrix T5x-04 Treadmill offers a variety of level-based workouts to challenge users of all fitness levels. The following information will briefly explain the workouts and how to program the treadmill for each workout selection.

ROLLING HILLS WORKOUT OPERATION

Rolling Hills is a level based workout that automatically adjusts the incline value to simulate walking or running up hills.

- 1) Choose ROLLING HILLS by selecting the rolling hills workout button and press ENTER.
- 2) Enter the desired intensity using the ARROW KEYS or the NUMBER KEYPAD and press ENTER.
- 3) Enter the desired workout length using the ARROW KEYS or the NUMBER KEYPAD and press ENTER.
- 4) Enter user weight (user weight is used to calculate the caloric expenditure value, providing an accurate weight helps to ensure an accurate caloric expenditure rating for each user) using the ARROW KEYS or the NUMBER KEYPAD and press ENTER.
- 5) Press GO or QUICK START to begin the workout.

FAT BURN WORKOUT OPERATION

Fat Burn is a level-based workout that is designed to help users burn fat through various incline changes.

- 1) Choose FAT BURN by selecting the fat burn workout button and press ENTER.
- 2) Enter the desired intensity level using the ARROW KEYS or the NUMBER KEYPAD and press ENTER.
- 3) Enter the desired workout length using the ARROW KEYS or the NUMBER KEYPAD and press ENTER.
- 4) Enter user weight (user weight is used to calculate the caloric expenditure value, providing an accurate weight helps to ensure an accurate caloric expenditure rating for each user) using the ARROW KEYS or the NUMBER KEYPAD and press ENTER.
- 5) Press GO or QUICK START to begin the workout.

4.4 HEART RATE CONTROL WORKOUT OPERATION

Your Matrix T5x-04 Treadmill offers a heart rate control workout mode. The heart rate control workout mode allows the user to program their desired heart rate zone and maximum allowable incline and the treadmill will automatically adjust the incline based upon the user's heart rate. The heart rate zone is calculated using the following equation: $(220 - \text{Age}) * \% = \text{target heart rate zone}$. The user must wear a telemetric heart rate monitor or continually hold onto the contact heart rate grips for his workout.

- 1) Choose TARGET HEART RATE by selecting the target heart rate workout button and press ENTER.
- 2) Enter age using the ARROW KEYS or the NUMBER KEYPAD and press ENTER.
- 3) Enter the desired percent of maximum heart rate using the ARROW KEYS or the NUMBER KEYPAD and press ENTER.
- 4) Enter user weight (user weight is used to calculate the caloric expenditure value, providing an accurate weight helps to ensure an accurate caloric expenditure rating for each user) using the ARROW KEYS or the NUMBER KEYPAD and press ENTER.
- 5) Press GO or QUICK START to begin the workout.

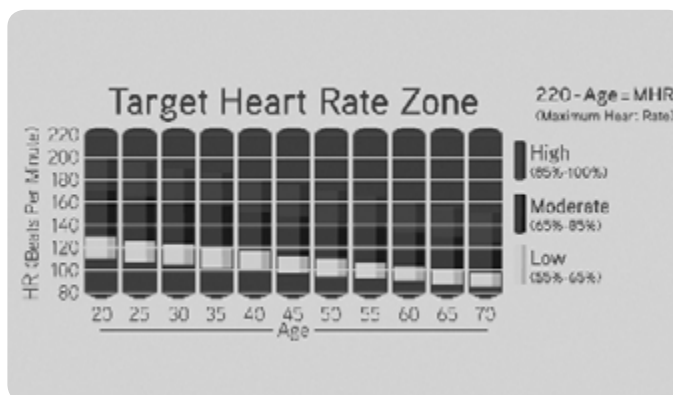

4.5 FITNESS TEST WORKOUT OPERATION

Your Matrix T5x-04 Treadmill offers a variety of fitness tests - the Gerkin Firefighter Protocol, the Army, Navy, USMC, and USAF as well as the Physical Efficiency Battery (PEB).

The Gerkin Protocol was developed by Dr. Richard Gerkin of the Phoenix (Arizona) Fire Department. It is a sub-maximal graded treadmill evaluation used by many fire departments across the United States to assess the physical condition of the firefighters. The test requires constant monitoring of the user's heart rate so the use of a telemetric chest strap is highly encouraged. The workout operates as follows:

- WARM UP:** The warm up is 3 minutes long and runs at 3.0 mph (4.8 kph) and 0% incline.
- STAGE 1:** At the 3 minute mark, the treadmill will gradually increase speed to 4.5 mph (7.2 kph). The actual test begins at 4.5 mph (7.2 kph).
- STAGE 2:** After one minute, the treadmill incline will increase to 2%.
- STAGE 3:** After one minute, the treadmill speed increases to 5.0 mph (8.0 kph).
- STAGES 4 THROUGH 11:** After every odd minute the treadmill incline will increase by 2%. After every even minute the treadmill speed will increase by 0.5 mph (0.8 kph). Once the user's heart rate exceeds the target heart rate (85% of maximum as determined by the equation $(220 - \text{Age}) * \% = \text{target heart rate zone}$), the individual continues the evaluation for an additional 15 seconds. During the 15 second period, the evaluation remains at the stage where the target heart rate is exceeded, without any change to speed or incline. If the heart rate does not return to or below the target heart rate, the evaluation ends and the final evaluation stage is recorded. If the heart rate returns to or below the target heart rate, the program continues at the point where it would have been had the program not stabilized for 15 seconds.
- TEST COMPLETION:** The test is completed when user's heart rate exceeds the target for more than 15 seconds or when the user completes all 11 stages, whichever occurs first. The treadmill will enter a cool down cycle for 3 minutes at 3.0 mph (4.8 kph), 0% incline.

- 1) Choose the GERKIN TEST by pressing the fitness test workout button until Gerkin is shown in the message window and press ENTER.
- 2) Enter user's age using the ARROW KEYS or the NUMBER KEYPAD and press ENTER.
- 3) The message window will display your target heart rate based upon your age and the target heart rate zone of 85%.
- 4) Select gender using the ARROW KEYS and press ENTER.
- 5) Enter user weight (user weight is used to calculate the caloric expenditure value, providing an accurate weight helps to ensure an accurate caloric expenditure rating for each user) using the ARROW KEYS or the NUMBER KEYPAD and press ENTER.
- 6) The message window will notify the user that the start speed is 3.0 mph (4.8 kph) and 0% incline during the warm-up.
- 7) Press GO or QUICK START to begin workout.

CHAPTER 4: CONSOLE OVERLAY AND WORKOUT DESCRIPTION

4.5 FITNESS TEST WORKOUT OPERATION - CONTINUED

SUB MAXIMAL TREADMILL EVALUATION CONVERSION TABLE

Stage	Time	Converted VO2max
1	1:00	31.15
2.1	1:15	32.55
2.2	1:30	33.6
2.3	1:45	34.65
2.4	2:00	35.35
3.1	2:15	37.45
3.2	2:30	39.55
3.3	2:45	41.3
3.4	3:00	43.4
4.1	3:15	44.1
4.2	3:30	45.15
4.3	3:45	46.2
4.4	4:00	47.5
5.1	4:15	48.6
5.2	4:30	50
5.3	4:45	51.4
5.4	5:00	52.8
6.1	5:15	53.9
6.2	5:30	54.9
6.3	5:45	56
6.4	6:00	57
7.1	6:15	57.7
7.2	6:30	58.8
7.3	6:45	60.2
7.4	7:00	61.2
8.1	7:15	62.3
8.2	7:30	63.3
8.3	7:45	64
8.4	8:00	65
9.1	8:15	66.5
9.2	8:30	68.2
9.3	8:45	69
9.4	9:00	70.7
10.1	9:15	72.1
10.2	9:30	73.1
10.3	9:45	73.8
10.4	10:00	74.9
11.1	10:15	76.3
11.2	10:30	77.7
11.3	10:45	79.1
11.4	11:00	80

CARDIOVASCULAR FITNESS PERCENTILES

Males:	VO2 max (ml/kg/min)			
	0-29	30-39	40-49	50-59
SUPERIOR	>58.8	>58.9	>55.4	>52.5
	54.0	52.5	50.4	47.1
EXCEL- LENT	51.4	50.3	48.2	45.3
	48.2	46.8	44.1	41.0
GOOD	46.8	44.6	41.8	38.5
	44.2	42.4	39.9	36.7
FAIR	42.5	41.0	38.1	35.2
	41.0	38.9	36.7	33.8
POOR	39.5	37.4	35.1	32.3
	37.1	35.4	33.0	30.2
VERY POOR	34.5	32.5	30.9	28.0
	31.6	30.9	28.3	25.1

Females:	VO2 max (ml/kg/min)			
	20-29	30-39	40-49	50-59
SUPERIOR	>53.0	>48.7	>46.8	>42.0
	46.8	43.9	41.0	36.8
EXCEL- LENT	44.2	41.0	39.5	35.2
	41.0	38.6	36.3	32.3
GOOD	38.1	36.7	33.8	30.9
	36.7	34.6	32.3	29.4
FAIR	35.2	33.8	30.9	28.2
	33.8	32.3	29.5	26.9
POOR	32.3	30.5	28.3	25.5
	30.6	28.7	26.5	24.3
VERY POOR	28.3	26.5	25.1	22.3
	25.9	25.1	23.5	21.1

The Military Test programs and the Physical Efficiency Battery (PEB) provide workouts of a preset distance. These distances are established by the various branches of the Military with the objective of each test to complete the distance as quickly as possible. At the completion of the test, a time-based score as defined by the respective Military branch will be shown on the console.

- 1) Choose your desired Military test by pressing the FITNESS TEST WORKOUT button until your desired branch test is shown in the message window and press enter.
- 2) Enter user's age using the ARROW KEYS or the NUMBER KEYPAD and press ENTER.
- 3) Select gender using the ARROW KEYS and press ENTER.
- 4) Enter user weight (user weight is used to calculate the caloric expenditure value, providing an accurate weight helps to ensure an accurate caloric expenditure rating for each user) using the ARROW KEYS or the NUMBER KEYPAD and press ENTER.
- 5) Enter the desired start speed using the ARROW KEYS or the NUMBER KEYPAD and press ENTER.
- 6) Press GO or QUICK START to begin the workout.

CHAPTER 5: MANAGER MODE

5.1 USING MANAGER MODE

- 1) To enter Manager Mode, press & hold INCLINE DOWN and SPEED DOWN at the same time for 3-5 seconds until Manager Mode appears on the display.
- 2) To enter the Manager Mode, press ENTER once Manager Mode appears on the display.
- 3) To scroll between programs in the Manager Mode, press any UP or DOWN arrow key.
- 4) Press ENTER to modify the program settings once displayed.
- 5) Press any UP or DOWN arrow key to change value.
- 6) Once program setting is correct, press ENTER to save.
- 7) Press the EMERGENCY STOP to exit Manager Mode..



5.2 MANAGER MODE OVERVIEW

CUSTOM SETTINGS	DEFAULT	MINIMUM	MAXIMUM	UNIT	DESCRIPTION
MAXIMUM TIME	60	5	99	MINUTE	Maximum workout duration.
DEFAULT TIME	60	5	99 (LIMITED TO MAX TIME SETTING)	MINUTE	Default start time in all programs.
DEFAULT LEVEL	1	1	10	LEVEL	Default start level in all programs.
DEFAULT AGE	30	15	100	AGE	Default age used in HR programs.
DEFAULT WEIGHT	150 LB / 68 KG	50 LB / 23 KG	400 LB / 182 KG	POUND / KILOGRAM	Default weight used in calorie calculations and HR programs.
ACCUMULATED DISTANCE	N/A	N/A	65,000 MILES / 104,000 KM	MILE / KILOMETER	Total distance on treadmill, not editable. TO RESET: Press and hold INCLINE DOWN and SPEED DOWN for 3-5 seconds.
ACCUMULATED TIME	N/A	N/A	65,000 HOURS	HOUR	Total time on treadmill, not editable. TO RESET: Press and hold INCLINE DOWN and SPEED DOWN for 3-5 seconds.
SOFTWARE	N/A	N/A	N/A	N/A	Software Version, not editable.
START SPEED	0.5 MPH / 0.8 KPH	0.5 MPH / 0.8 KPH	1.4 MPH / 2.3 KPH	MPH / KPH	Controls the starting speed for all programs (does not affect minimum speeds).
MAXIMUM SPEED	12 MPH / 20 KPH	2.0 MPH / 3.2 KPH	15 MPH / 24.1 KPH	MPH / KPH	Controls the maximum speed for all programs.
DEFAULTCHANNEL	1	1	30	CHANNEL	Controls the default channel for entertainment wired through the C-Safe port.
TIMER MODE	DOWN	DOWN	UP	N/A	Controls whether the user time counts up or down.
SPEED MODE	MILE	MILE	KILOMETER	N/A	Measurement unit used for calorie calculations, distance, and speed.
OUT OF ORDER	NO	NO	YES	N/A	Locks the machine.
GENDER	MALE	MALE	FEMALE	N/A	Sets the user's gender.
LANGUAGE	ENGLISH	N/A	N/A	N/A	Sets the language shown on the console.
SOUND MODE	ON	ON	OFF	N/A	Controls whether the display broadcasts chime when buttons are pressed.
NAVY TEST SITE	0	0	1	N/A	This option controls the default altitude used in the fitness test score calculations. 0: Test site elevation less than 5000 ft above sea level. 1: Test site elevation more than 5000 ft above sea level.
BELT STOP	OFF	OFF	90	SECONDS	Belt Stop function for user's existence detect.

CHAPTER 6: ENGINEERING MODE

6.1 USING ENGINEERING MODE

1. To enter Engineering Mode, hold the INCLINE DOWN and SPEED DOWN keys for three seconds until Manager Mode appears on the middle LED display.
2. Press any UP arrow key and Engineering Mode will appear on the display.
3. Press ENTER once Engineering Mode is displayed.
4. To scroll between programs in the Engineering Mode, press any UP or DOWN arrow key.
5. Press ENTER to modify the program settings once displayed.
6. Press any UP or DOWN arrow key to change value.
7. Once program setting is correct, press ENTER to save.
8. Press the EMERGENCY STOP to exit Engineering Mode.

6.2 ENGINEERING MODE OVERVIEW

CUSTOMSETTING	DEFAULT	MINIMUM	MAXIMUM	UNIT	DESCRIPTION
Disable Errors	OFF	ON	OFF	N/A	ON - Shows A-C class error codes. OFF - Shows only C class error codes.
Elevation Minimum	28	20	239	N/A	Controls the low incline parameter.
Elevation Maximum	230	20	239	N/A	Controls the high incline parameter.
Auto Calibration	N/A	N/A	N/A	N/A	This function is to calibrate the treadmill incline.
Speed Units	MILE	MILE	KILOMETER	DISTANCE	Measurement unit used for calorie calculations, distance, and speed.
Pause Time	5 MINUTES	30 SECONDS	10 MINUTES	SECONDS / MINUTES	Controls the maximum time the treadmill can be paused during a workout.
Serial Number	N/A	N/A	N/A	N/A	<p>Serial Number input is available for both the Console and Frame. Use the number keys and UP / DOWN LEVEL keys to enter Engineering Mode. Due to the limited LED characters, 2 layers are used to enter the serial number. First Layer:</p> <ul style="list-style-type: none"> - P P P P P V - P P P P P is the product name. - V is the version. If the version is A, just leave this blank. <p>Second Layer</p> <ul style="list-style-type: none"> - Y Y M M n n n n n - Y Y is the year (11, 12). - M M is the month (e.g. 08, 09, 10). - n n n n n is the actual serial number. <p>Use the UP / DOWN LEVEL keys to navigate the layers and the number keys to input the serial number. The product name is dependent on the Machine Type setting.</p> <p>For example, the console is TM519 with ver. A and the manufactured date is 2012.09 with 18765. The frame is TM501 with ver. E and the manufactured date is 2012.09 with 12345. Their serial numbers are: Console SN: TM519 1st layer, 120918765 2nd layer. Frame SN: TM501E 1st layer, 120912345 2nd layer.</p>
Reset Default	N/A	N/A	N/A	N/A	Reset default data to original.
Club ID	63	N/A	N/A	N/A	This sets the club ID for clubs using Asset Management.
Audio Source	OFF	OFF / TV / PCTV / REMOTE TV		N/A	a. Off – no TV (keypad will not operate) b. TV – All normal MYE TVs. c. PCTV – All PCTVs (net based TV). d. Remote TV – Wall mounted TVs with 900MHz receiver.
Volume Control	OFF	A. INPUT DEFAULT :15 B. MAX DEFAULT :32 C. OUTPUT DEFAULT :13		N/A	Controls the default TV volume for entertainment wired through the C-Safe port. a. Input Default (DF : 15 / Range : 1 ~ 15) b. Max Default (DF : 32 / Range : 1 ~ 32) c. Output Default (DF : 13 / Range : 1 ~ Max) Remote TV support a / b / c item. TV and PCTV only support c item.
AM System	RF RADIO			N/A	To select AM output device by WIFI or RF Radio.
ERP mode (Sleep time)	OFF	OFF OR 0:01(MINUTES)~0:30(MINUTES)		N/A	If there is no use of the machine over a period of time, the console LEDs will turn off (go into sleep mode).

CHAPTER 7: SERVICE MODE

7.1 USING SERVICE MODE

1. To enter Service Mode, hold the INCLINE DOWN and SPEED DOWN keys for three seconds until Manager Mode appears on the middle LED display.
2. Press any DOWN arrow key and Service Mode will appear on the display.
3. Press ENTER once Service Mode is displayed.
4. To scroll between programs in the Service Mode, press any UP or DOWN arrow key.
5. Press ENTER to modify the program settings once displayed.
6. Press any UP or DOWN arrow key to see value.
7. Press the EMERGENCY STOP to exit Service Mode.

7.2 SERVICE MODE OVERVIEW

CUSTOM SETTINGS	DEFAULT	OPTIONS	DESCRIPTION
Service 1	Display Test		Press the ENTER key repeatedly to check each set of LEDs on the display sequentially.
Service 2	Keypad Test		Press any key and the display should show the corresponding message.
Service 3	Accumulated Distance / Accumulated Time	Distance: Mile 0 - 99999 Kilometer 0 - 160898 Time: 0 - 999999	Manually sets the Accumulated Distance and Time.
Service 4	CSafe / RF Test		Press the ENTER key to test CSAFE. Press the ENTER key again to test the RF.
Service 5	Error Log Message		Shows the last 10 errors. Press and hold INCLINE DOWN and SPEED DOWN keys for 3 seconds to clear the errors.
Service 6	Setting the PCB System Date Data		Displays the current time
Service 7	Export and Import Parameter		Export parameter : Export all parameter to USB Import parameter 1: Import parameters to console without accumulated distance and time and serial number. Import parameter 2: Import parameters to console Include accumulated distance and time and serial number.
Service 8	WiFi Function		Automatically detects the available IP address and displays it.

8.1 ELECTRICAL DIAGRAMS

Digital Communication Wire

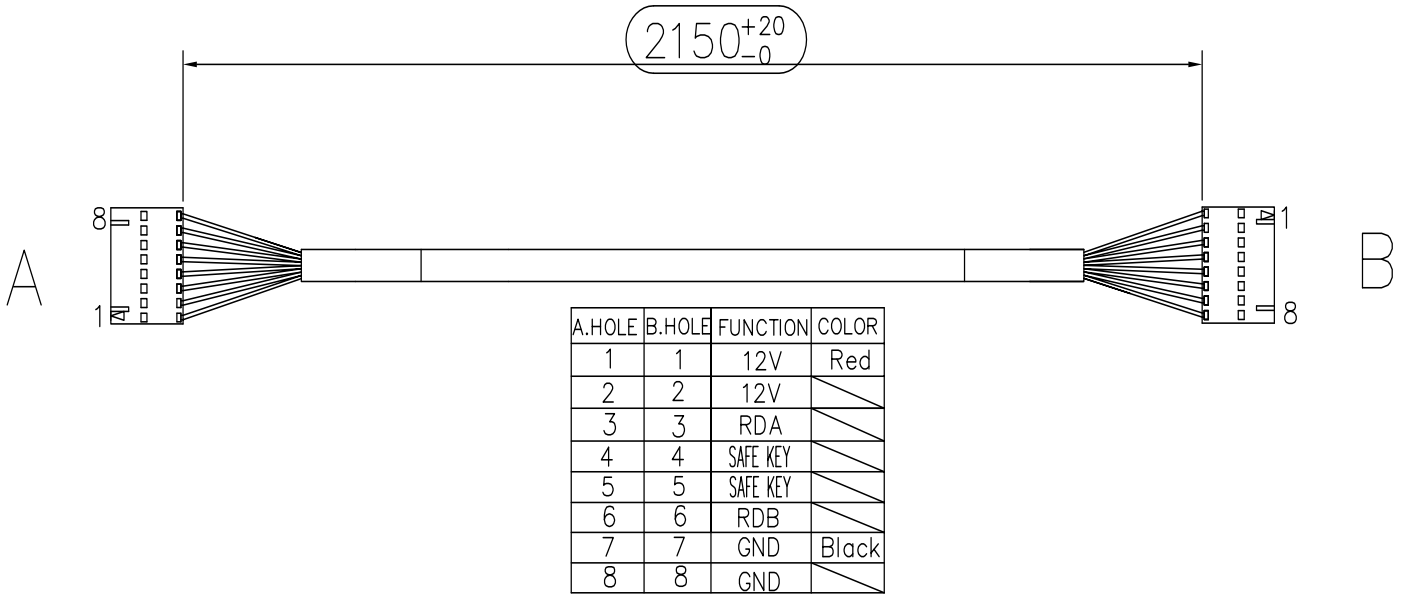

UCB Little Board Wire

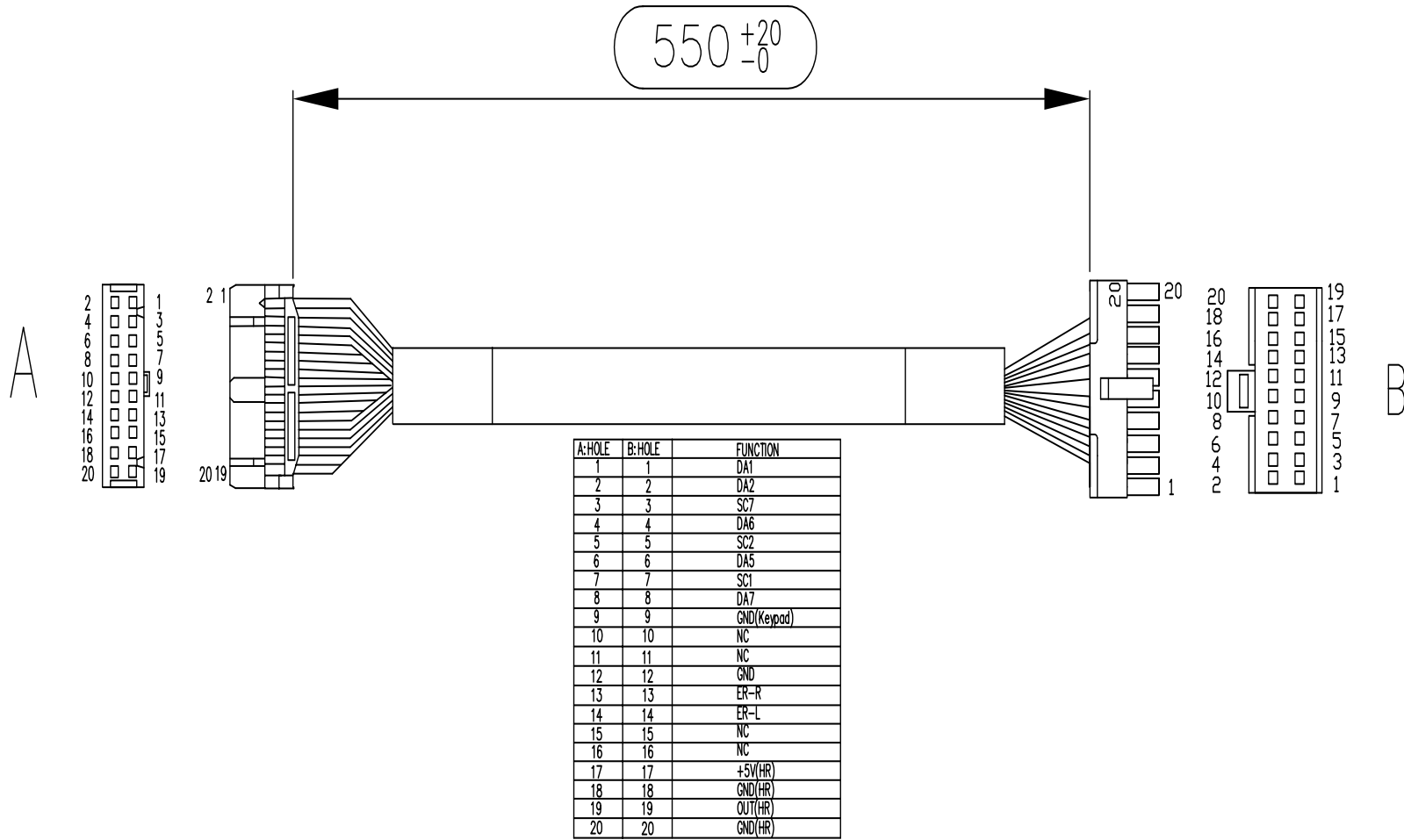

8.1 ELECTRICAL DIAGRAMS

Hand Pulse Sensor Wire

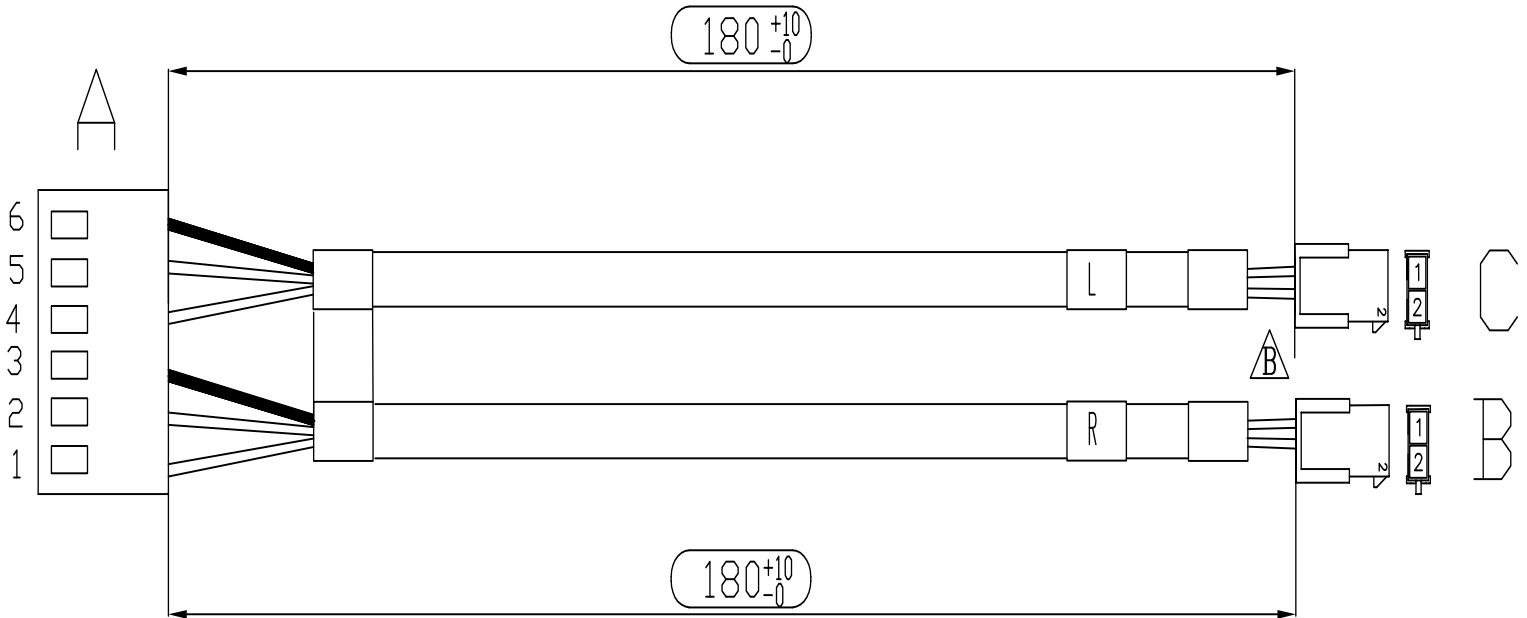

A.HOLE	B.HOLE	C.HOLD	FUNCTION	COLOR
1	1		RT-PRI	RED
2	2		RT-SEC	WHITE
3			GROUND	Shielding
4		1	LT-PRI	RED
5		2	LT-SEC	WHITE
6			GROUND	Shielding

Hand Pulse Wire

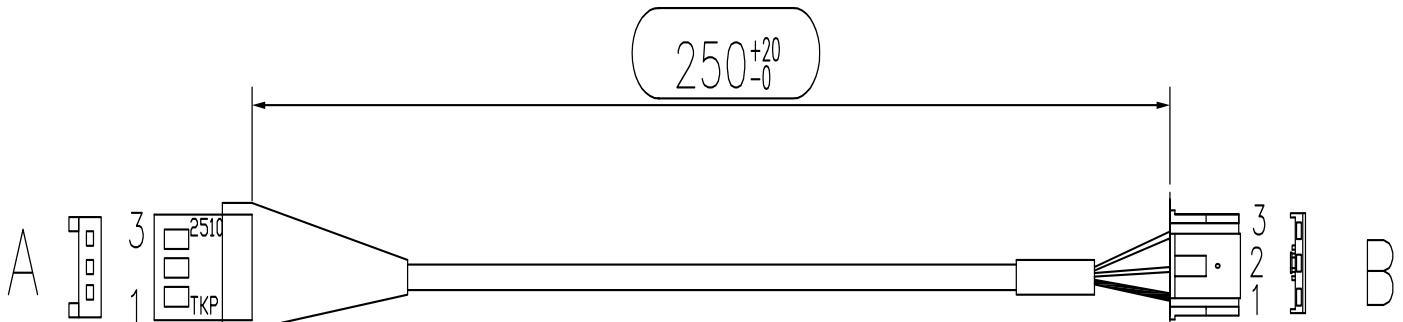

A.HOLE	B.HOLE	COLOR	FUNCTION
1	1	Black	A:GND no Shield B: GND add Shield
2	2	Red	VCC
3	3		SGN

CHAPTER 8: TROUBLESHOOTING

8.2 MCB LED INSTRUCTIONS

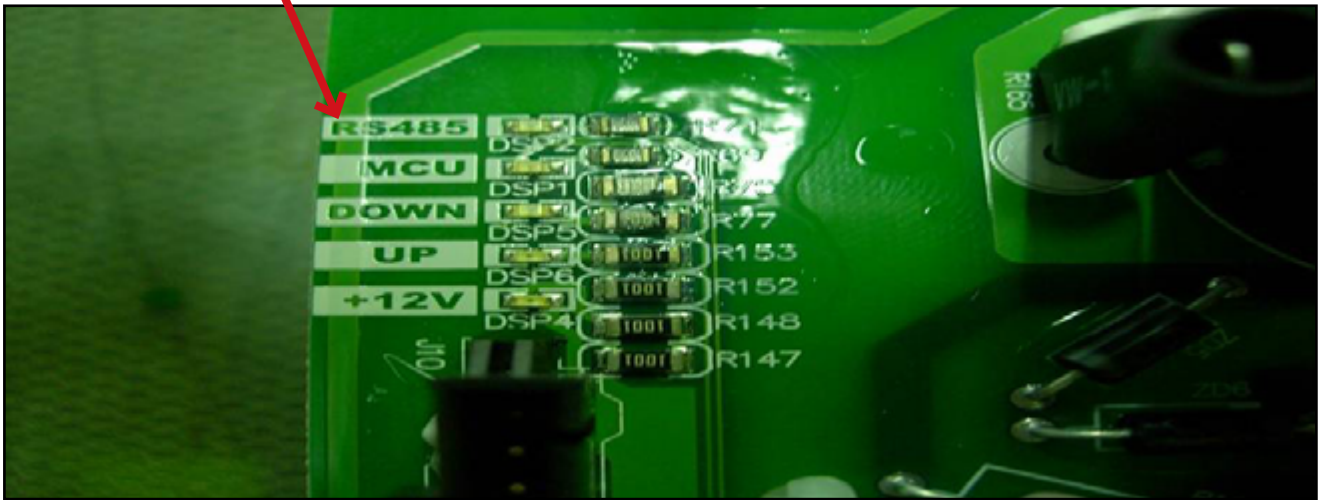
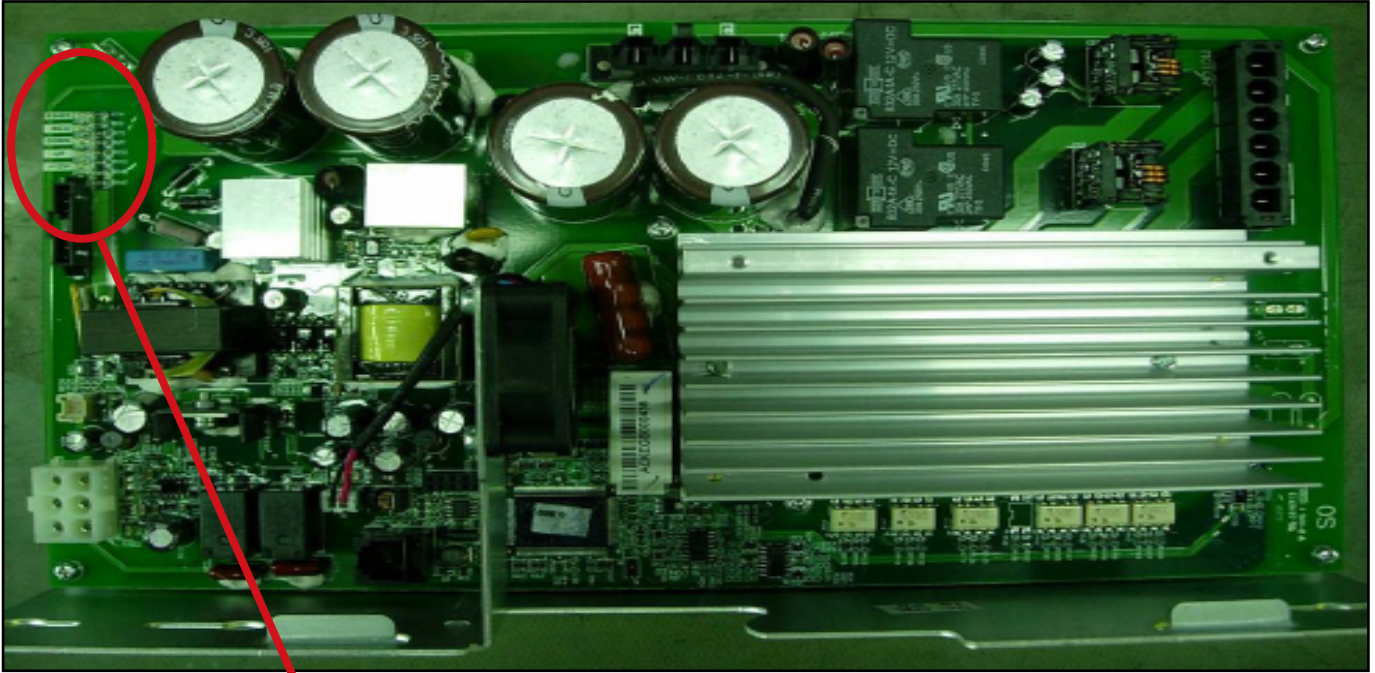

LED	REFERENCE DESIGNATOR	DESCRIPTION
RS485	DSP2	Indicates if the digital communication is working normally between the console and the MCB. Blinking = Normal. Off = Fault
MCU	DSP1	Indicates if the console is working normally. Blinking - Normal. Light = MCU Fault. Off = MSU No Power.
DOWN	DSP5	Indicates if the console is commanding elevation down. Light = Normal. Off - No command from console received by the elevation motor.
UP	DSP6	Indicates if the console is commanding elevation up. Light = Normal. Off = No command from console received by the elevation motor.
+12V	DSP4	Indicates if the console voltage supply is present. Light = Normal. Off - 12 Volts are not provided by the MCB.

8.3 MCB WIRING

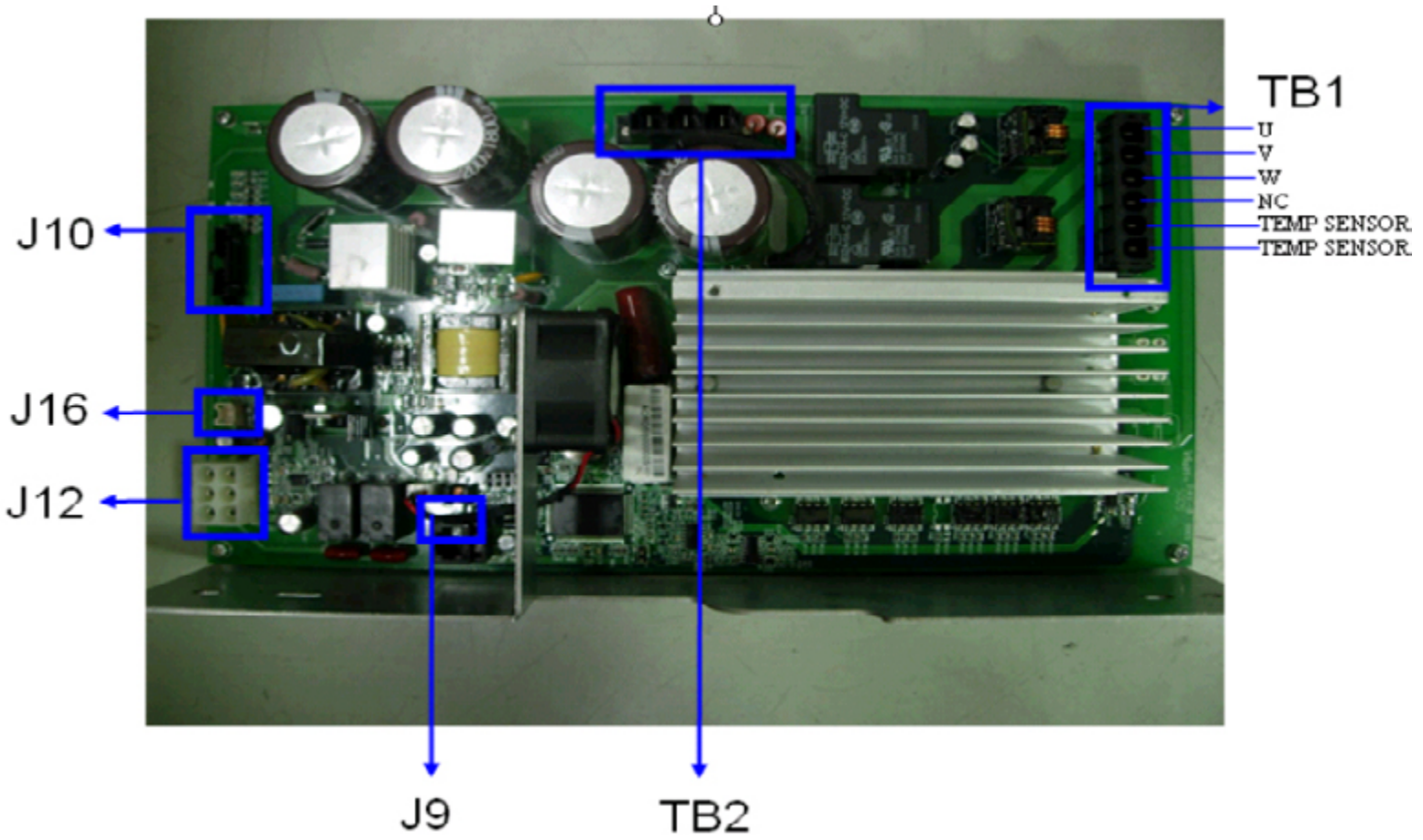

- TB1 - AC Motor Cable Socket**
- TB2 - Input Power Cable Socket**
- J9 - Inside Fan Cable Socket**
- J10 - Digital Communication Cable Socket**
- J12 - Elevation Motor Cable Socket**
- J16 - External Fan Cable Socket**

8.4 0140 / 01A0 / 01A2 ERROR TROUBLESHOOTING

ERROR MESSAGES 0140 / 01A0 / 01A2

1) SYMPTOM:

- a. 0140 - Incline motor operation failed.
- b. 01A0 - Incline motor disconnected.
- c. 01A2 - Incline motor is detected in the reverse of the position indicated by the potentiometer.

2) SOLUTION

- a. Check the connection of the incline motor cable at the MCB.
- b. Run auto calibration (See Section 3.4).
- c. If auto calibration fails, re-enter Engineering Mode and scroll until Elevation Minimum is displayed, then press ENTER.
 - Check the MCB LEDs. If LED DOWN (Figure A) has no light, check the console cable connections at the console and MCB.
- d. If the incline motor does not resolve the issue, replace the MCB.



FIGURE A

8.5 01A3 ERROR TROUBLESHOOTING

ERROR MESSAGE 01A3

1) SYMPTOM:

- a. Motor is disconnected.

2) SOLUTION:

- a. Check the connection of the motor cable at the MCB (Figure A).
- b. Check to see if the MCB LED DSP1 (MCU) is lit (Figure B).
- c. If LED DSP1 is blinking, the motor should be replaced.
- d. If LED DSP1 is a solid light, replace the motor.
- e. If LED DSP1 is not lit, replace the MCB.

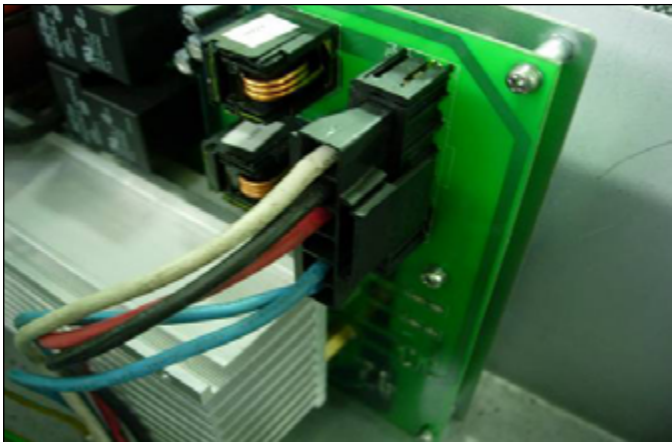

FIGURE A

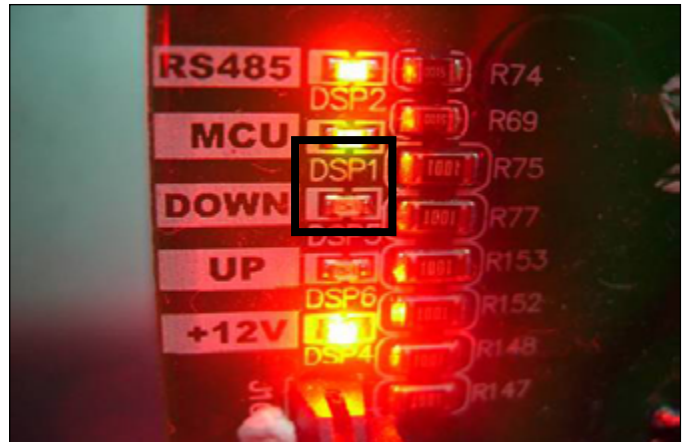

FIGURE B

8.6 01A8 / 02B6 / 02B7 / 02B8 ERROR TROUBLESHOOTING

ERROR MESSAGE 01A8 / 02B6 / 02B7 / 02B8

1) SYMPTOM:

- a. 01AB - Motor over current.
- b. 02B6 - Speed up is overcurrent.
- c. 02B7 - Speed down is overcurrent.
- d. 02B8 - Running status is overcurrent.

2) SOLUTION:

- a. Check the condition of the running deck and belt. Replace the belt and flip or replace the running deck as needed.
- b. Replace the MCB.

8.7 01AD ERROR TROUBLESHOOTING

ERROR MESSAGE 0X029F

1) SYMPTOM:

- a. Motor over temperature.

2) SOLUTION:

- a. Check the connection of the motor cable at the MCB (Figure A).
- b. Use a multi-meter to check the motor wire circuit. Set the multi-meter to Ohms and place both terminals on the blue wires of the motor cable (Figure B). There should be an Ohm reading of 0. If there is an Ohm reading above 0, replace the motor. If the Ohm reading is 0, replace the MCB.

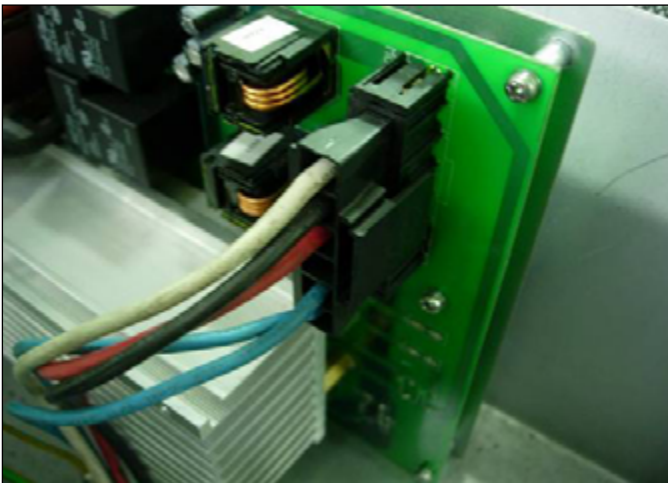

FIGURE A



FIGURE B

8.8 02AD ERROR TROUBLESHOOTING

ERROR MESSAGE 02AD

1) SYMPTOM:

- a. MCB is over temperature.

2) SOLUTION:

- a. Check to see that both fans are operating (there is a fan mounted to the MCB itself as well as an external fan). Also check the connection of the fans at the MCB (Figure A).
- b. If the fans are running correctly, replace the MCB.

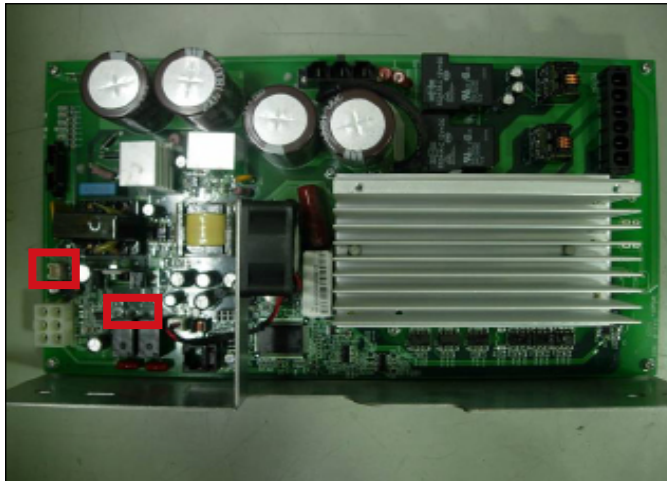

FIGURE A

8.9 02B2 ERROR TROUBLESHOOTING

ERROR MESSAGE 02B2

1) SYMPTOM:

- a. The emergency circuit on the interface board active.

2) SOLUTION:

- a. Check the connection of the safety key (emergency stop) switch (Figure A). If the switch is always open or shorted out, replace the switch.
- b. If the emergency stop does not resolve the issue, replace the console.



FIGURE A

8.10 02B9 / 02BA / 02BD ERROR TROUBLESHOOTING

ERROR MESSAGE 02B9 / 02BA / 02BD

1) SYMPTOM:

- a. 02B9 - The inner memory IC data write error.
- b. 02BA - The inner memory IC data read error.
- c. 02BD - Inverter hardware interrupt error.

2) SOLUTION:

- a. Check LED DSP1 (MCU) on the MCB (Figure A).
- b. If this LED is blinking, replace the console.
- c. If this LED is a constant light, replace the MCB.
- d. If this LED is not lit at all, check the power to the MCB.

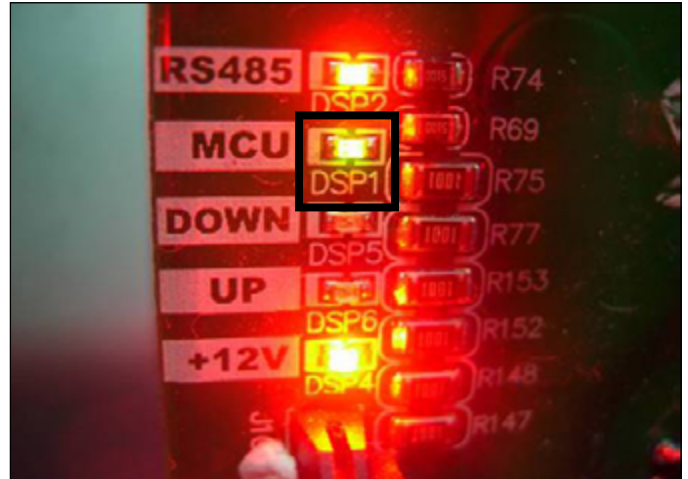

FIGURE A

8.11 04A0 ERROR TROUBLESHOOTING

ERROR MESSAGE 04A0

1) SYMPTOM:

- a. No communication received.

2) SOLUTION:

- a. If the display is giving an 04A0 error, LED DSP2 (RS485) should be off (Figure A). If this light is not on and an 04A0 error is present, replace the console.
- b. Check the connection of the console communication cable at both the console and the MCB.
- c. Replace the console communication cable.
- d. Replace the MCB.

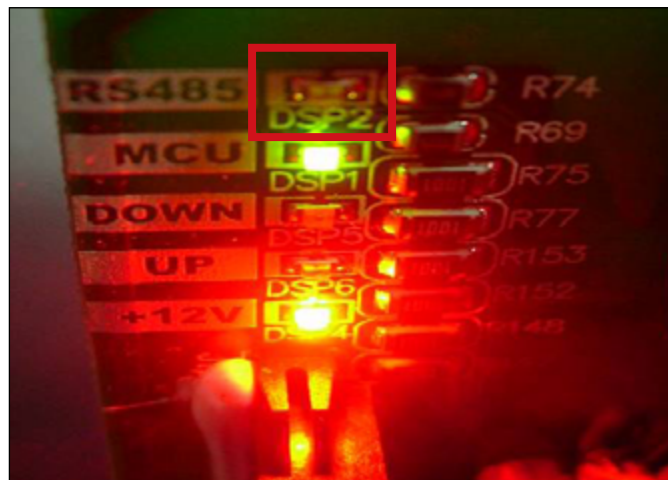

FIGURE A

8.12 TROUBLESHOOTING - NO POWER TO THE CONSOLE

POWER SWITCH IS ON, BUT THE CONSOLE HAS NO DISPLAY

1) SYMPTOM:

- a. The unit is not getting power from the outlet.
- b. The MCB is not getting power from the power receptacle.
- c. The power switch and MCB LEDs are lit, but there is no power to the console.

2) SOLUTION:

- a. Check to see if the power switch is lit. If it is not, plug the power cord into a known working outlet and re-test.
- If the power switch is still not lit, replace the power switch, receptacle, and / or the power cord.
 - Remove the motor cover and check to see if LED +12V (DSP4) is lit on the MCB (Figure A).
 - If the LED +12V is not lit, check the incoming AC voltage to the MCB.
 - Replace the MCB if all power components are OK, and there is AC volts to the MCB.
 - If LED +12V is lit, check the connection of the console communication cable.
- If the console communication cable is connected correctly, please check the +12VDC whether have into console UCB (Figure B).
 - No power for console UCB , replace the console communication cable.
 - Have power for console UCB, but there is still no power to the console, replace the UCB.



FIGURE A



FIGURE B

8.13 TROUBLESHOOTING - HEART RATE ISSUES

HEART RATE ISSUES

1) SYMPTOM:

- a. No heart rate.
- b. No or high heart rate.

2) SOLUTION:

- a. With a multi meter set for DC Voltage, place one prong of the multi meter on each of the HR plates on the handlebar (Figure A). A correctly connected HR grip will have a DC Voltage reading of between 0.5 and 2.0. If this reading is correct, skip to Step b.
 - If the reading is not correct, remove the screws holding the 2 halves of the HR grip together and check the connection of the HR grip wiring to the grips (Figure B). Replace the grips if any damage is seen to the plates.
 - Remove the console to expose the HR board.
 - Check the connection of the HR grip wiring to the 6 pin Y cable attached to one side of the HR board. Use a multi meter set for ohms to verify the continuity of these wires. If the ohm reading is more than 1 (or not there at all), replace the HR grip wiring (this will require replacing the HR handlebar). If the ohm reading is correct, your issue is not with the HR grip / HR wire portion of the HR system.
- b. Perform a continuity test on the treadmill console (see Service Bulletin - Continuity Test on Matrix Treadmills).
 - Verify the HR board ground wire. With a multi meter set for ohms, place one prong on the HR board ground wire, and the other on the console ground screw. You should get a resistance reading of 1 or less. If you get a reading over 1 (or none at all), replace the HR board.
 - Check the continuity of the wire that goes from the HR board to the Translator Board. With a multi meter set for ohms, place one prong on the 3 pin wire connecting to the HR board (Figure C) and the other on where this wire connects to the Translator Board (Figure D). If you get a reading of over 1 (or no reading at all), replace this wire.
 - Check the connection of the wire that goes from the Translator Board to the UCB. Replace this wire if needed.
 - If all wiring checks out good and the unit is still having HR issues, replace the HR board.
 - If the HR board does not resolve the issue, replace the UCB.



FIGURE A



FIGURE B



FIGURE C



FIGURE D

8.14 TROUBLESHOOTING - SPEED SHOWN IS SLOWER THAN BELT SPEED

SCREEN SHOWS A HIGH SPEED, BUT THE BELT MOVING SLOWER THAN SHOWN

1) SYMPTOM:

- a. The unit speed does not match the console display.

2) SOLUTION:

- a. Perform an amp draw on the incoming power (see Field Work Instruction - Running an Amp Draw on Matrix Treadmills).
- b. If the amp draw is too high regardless if a user is present or not, the issue is likely with the drive system (drive belt or motor).
 - Make sure that there is enough tension from the idler on the drive belt so that it is not slipping.
 - Check the rotation of the motor to find any dead spots or a wobble in the motor axle.
 - Check the condition of the drive belt. Look for any wear or tears. Replace as needed.
- c. If the amp draw is too high with a user, the issue is likely with the deck / running belt.
 - Inspect the running deck for sticky or worn spots. If any wear is seen, flip the deck (it is waxed on both sides). A new running belt should be installed any time a running deck is flipped.
 - Replace the running belt.

9.1 MOTOR COVER AND LOWER SHROUD REMOVAL

- 1) The motor cover is split into two pieces (called the motor cover and lower shroud)
- 2) Remove the 2 screws holding motor cover to the frame (Figure A).
- 3) Pull up on the rear of the motor cover to release the Velcro, and remove the motor cover (Figure B).



FIGURE A



FIGURE B

- 4) Remove the 4 screws holding the lower shroud to the frame (Figure C).
- 5) Figure D shows a unit with both the motor cover and lower shroud removed.



FIGURE C



FIGURE D

9.2 REAR ROLLER REPLACEMENT

- 1) Turn off power and disconnect the cord from the machine.
- 2) Remove one of the end caps using a Phillips screwdriver (Figure A).
- 3) Remove both roller adjustment screws using an 8 mm Allen wrench (Figure B).



FIGURE A



FIGURE B

- 4) Remove the roller from the running belt (Figures C & D).



FIGURE C



FIGURE D

- 5) Reverse Steps 1-4 to install a new rear roller.
- 6) Tension the running belt as outlined in Section 3.5.

9.3 DECK REPLACEMENT

- 1) Remove the motor cover as outlined in Section 9.1.
- 2) Remove the rear roller as outlined in Section 9.2.
- 3) Remove the four deck screws using a 5 mm Allen wrench (Figure A).



FIGURE A

- 4) Remove the deck from the running belt (Figures B & C).



FIGURE B



FIGURE C

- 5) Reverse Steps 1-4 to install a new running deck. **NOTE:** The running deck is waxed on both sides so the opposite side surface may be usable. New running deck surfaces must ALWAYS be matched to a new running belt.
- 6) Tension the running belt as outlined in Section 3.5.

9.4 DECK CUSHION REPLACEMENT

- 1) Remove the deck as outlined in Section 9.3.
- 2) Holding the bolt with a 5 mm Allen wrench, loosen the nut with a 13 mm socket (Figure A & B).



FIGURE A



FIGURE B

- 3) For the rear cushion, hold the cushion and remove the 13 mm nut (Figure C).



FIGURE C

- 4) Reverse Steps 1-3 to install new deck cushions.
- 5) Tension the running belt as outlined in Section 3.5.

9.5 FRONT ROLLER REPLACEMENT

- 1) Remove the motor cover as outlined in Section 9.1.
- 2) Using a hook or loop of wire, remove the spring from the drive belt tensioner. The tensioner should now pivot away from the drive belt (Figures A & B).



FIGURE A



FIGURE B

- 3) Remove the front roller mounting screws using an 8 mm Allen wrench (Figures C & D).
- 4) Remove the drive belt from the front roller and remove the roller from the running belt (Figure E).



FIGURE C



FIGURE D



FIGURE E

- 5) Reverse Steps 1-4 to install a new front roller.
- 6) Tension the running belt as outlined in Section 3.5.

9.6 RUNNING BELT REMOVAL

- 1) Remove the motor cover as outlined in Section 9.1.
- 2) Remove the rear roller as outlined in Section 9.2.
- 3) Remove the deck as outlined in Section 9.3.
- 4) Remove the front roller as outlined in Section 9.5.
- 5) Remove the running belt and replace with a new belt (Figures A & B).

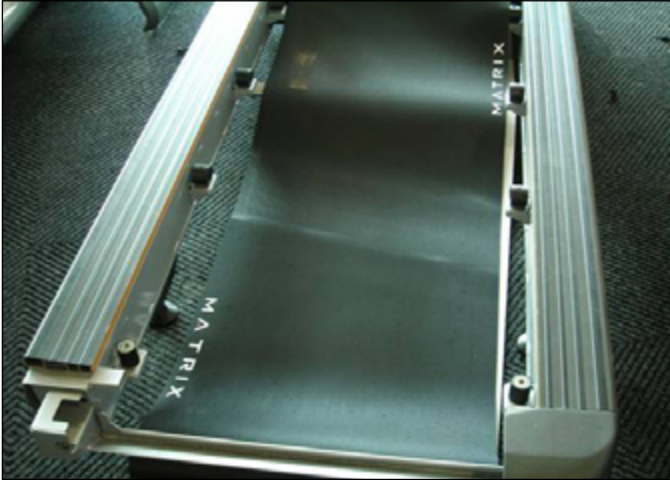

FIGURE A



FIGURE B

- 6) New running belts should ALWAYS be installed on a new deck surface (deck should either be flipped or replaced to gain a new surface).
- 7) Tension the running belt as outlined in Section 3.5.

9.7 SIDE RAIL REPLACEMENT

- 1) Remove the end cap using a Phillips screwdriver (Figure A).
- 2) Loosen the four screws under the frame using a 5 mm Allen wrench (Figure B).



FIGURE A



FIGURE B

- 3) Slide the rail off the back of the treadmill (Figures C & D).

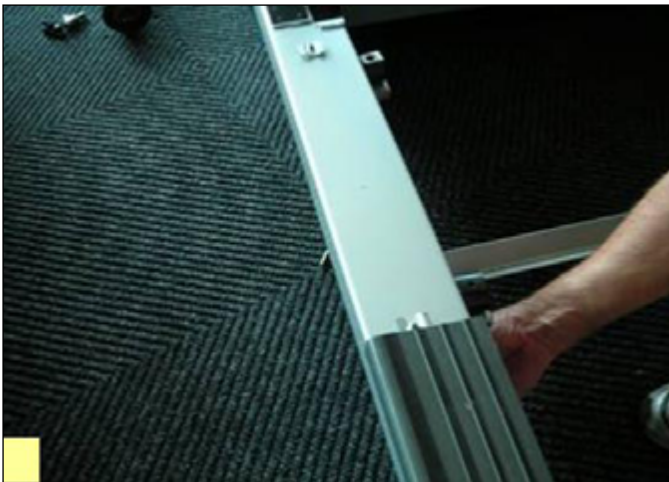

FIGURE C



FIGURE D

- 4) Reverse Steps 1-3 to install a new side rail.
- 5) After reinstalling the side rail, make sure end cap is on first before tightening screws for proper gap spacing. **NOTE:** Be careful not to over tighten the screws, or they will poke through the top of the side rail.

9.8 MOTOR CONTROL BOARD (MCB) REPLACEMENT

- 1) Turn off power and disconnect the cord from the machine.
- 2) Remove the motor cover as outlined in Section 9.1.
- 3) Cut any wire ties that are secured to the MCB panel.
- 4) Disconnect wires from the MCB - five total connections.
- 5) Remove two MCB mounting screws using a Phillips head screwdriver (Figures C & D).

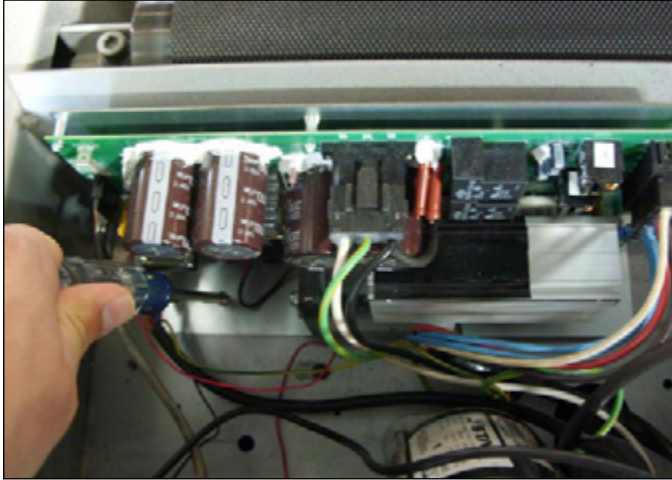

FIGURE A

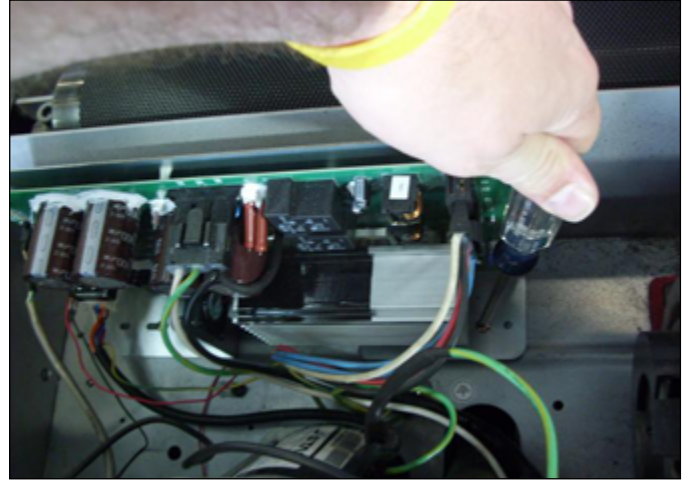

FIGURE B

- 6) Reverse Steps 1-5 to install a new MCB. Be sure to re-connect the 5 wires removed from the old MCB in Step 4 (Figure C). **NOTE:** The speed sensor wire from the motor is no longer used and can be tie strapped to a bracket.
- 7) Auto Calibration must ALWAYS be run after replacing the MCB (see Section 3.4).

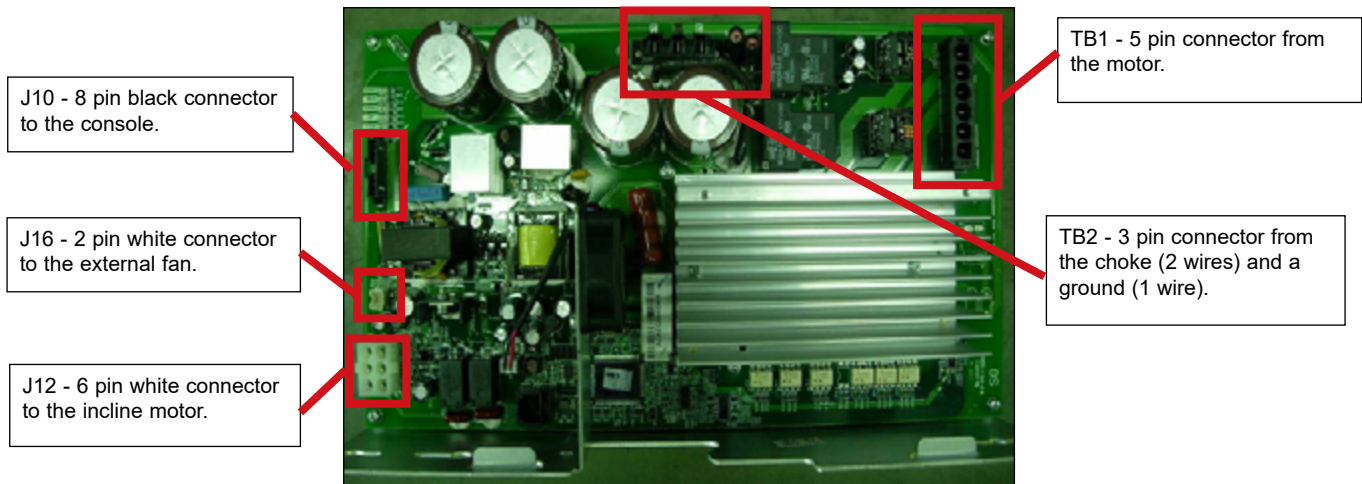

FIGURE C

9.9 MOTOR REPLACEMENT

- 1) Turn off power and disconnect the cord from the machine.
- 2) Remove the motor cover as outlined in Section 9.1.
- 3) Release the drive belt tensioner as outlined in Section 9.5.
- 4) Disconnect the motor power cable from the MCB (Figure A).
- 5) Use an 8 mm Allen wrench to remove the four motor mounting screws (Figure B).



FIGURE A



FIGURE B

- 6) Lift the motor away from the treadmill (Figure C).
 - 7) Reverse Steps 1-6 to install a new motor. **NOTE:** When reinstalling the motor, make sure the red vibration pad is in place (Figure D).
- NOTE:** The wire from the speed sensor on the motor is no longer used and can be tie strapped to the MCB bracket.
- 8) Auto Calibration must ALWAYS be run when installing a new motor. (see Section 3.4)



FIGURE C

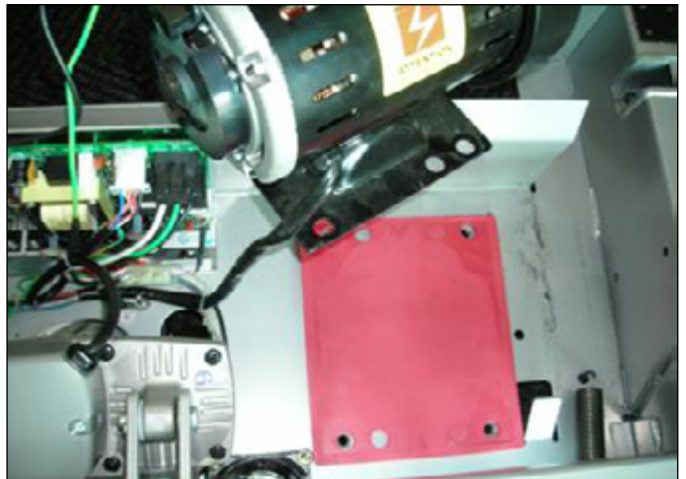

FIGURE D

9.10 DRIVE BELT REPLACEMENT

- 1) Remove the motor cover as outlined in Section 9.1.
- 2) Release the drive belt tensioner from drive belt as outlined in Section 9.5.
- 3) Remove the front roller screw on the drive belt side and loosen the screw on the opposite side (Figure A).



FIGURE A

- 4) Lift the roller and remove the old drive belt (Figure B).

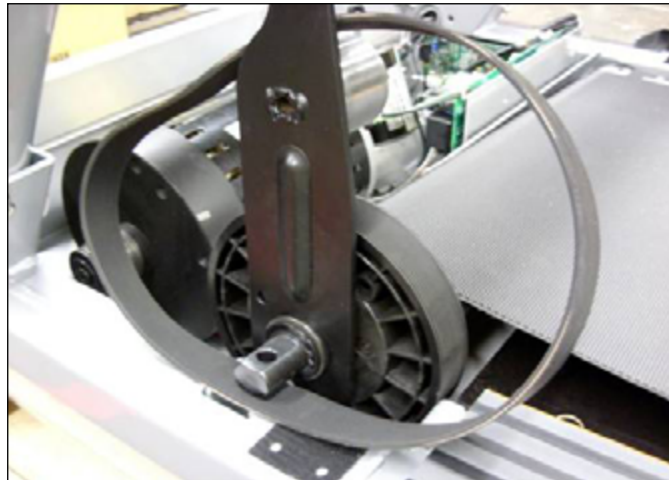

FIGURE B

- 5) After installing a new belt, check it for correct alignment to the motor pulley before setting the tensioner in place.

9.11 INCLINE MOTOR REPLACEMENT

- 1) Turn off power and disconnect the cord from the machine.
- 2) Lift the treadmill and support it so that the front wheels are off the floor, or the unit may be tipped on its side (Figure A).



FIGURE A



FIGURE B

- 3) Remove the clip from the pin attaching the incline motor to the rack (Figure B & C).



FIGURE C

9.11 INCLINE MOTOR REPLACEMENT - CONTINUED

- 4) Disconnect the incline motor power cable from the MCB (Figure D).
- 5) Disconnect the pin from the incline motor (Figure E).

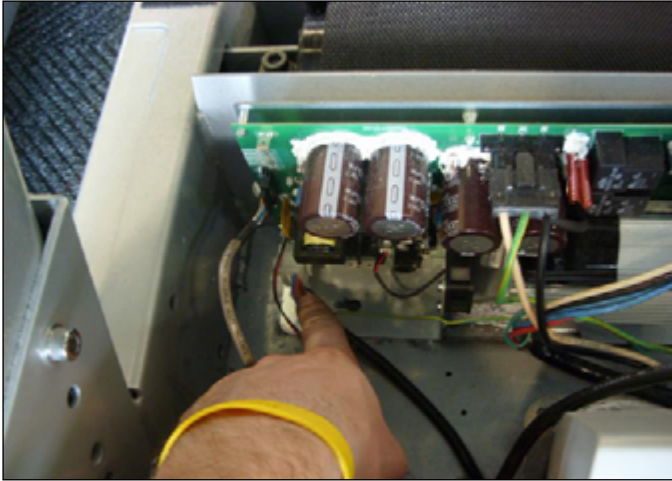

FIGURE D



FIGURE E

- 6) Lift the incline motor away from the treadmill (Figure F).
- 7) Reverse Steps 1-6 to install a new incline motor. **NOTE:** When installing the new incline motor, make sure to replace the white washers at the top and bottom (Figure G).

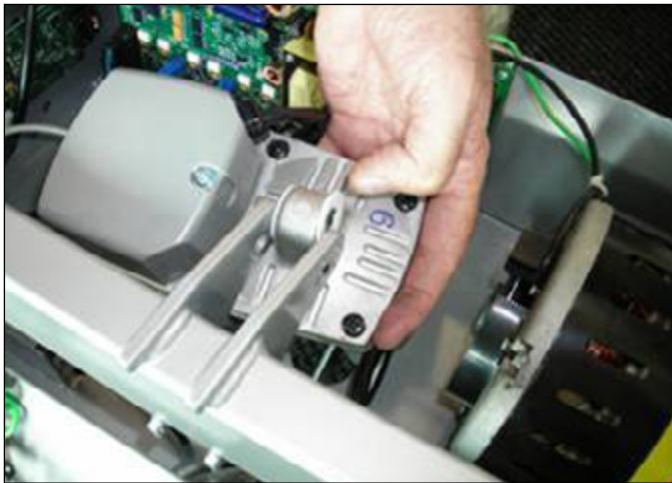

FIGURE F



FIGURE G

- 8) Auto Calibration must ALWAYS be run after replacing the incline motor (see Section 3.4).

9.12 CONSOLE REPLACEMENT

- 1) Turn off power and disconnect the cord from the machine.
- 2) Remove the back cover of the console (Figure A).
- 3) Disconnect the console cable connectors (Figure B).



FIGURE A

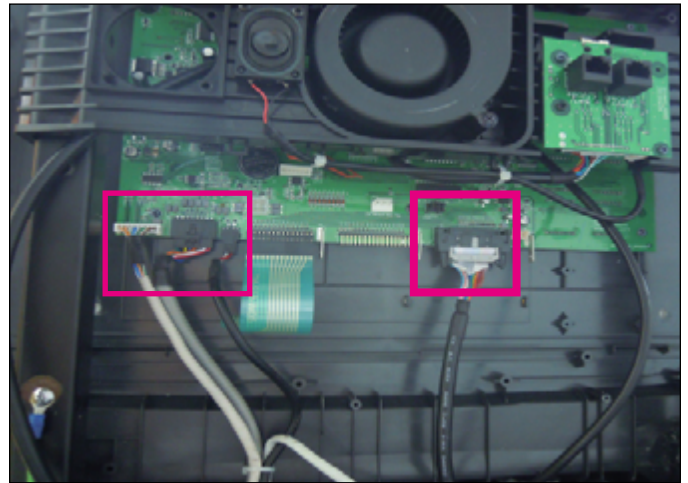

FIGURE B

- 4) Remove the six 6 mm screws from underneath the console. There are arrows stamped in the plastic at the proper openings (Figure C).
- 5) Move the console away from the console frame (Figure D).
- 6) Reverse Steps 1-5 to install a new console.



FIGURE C



FIGURE D

- 7) Auto Calibration must ALWAYS be run after replacing the console (see Section 3.4).

9.13 CONSOLE MAST ARM REPLACEMENT

- 1) Turn off power and disconnect the cord from the machine.
- 2) Remove the console as outlined in Section 9.12.
- 3) Take off the cup holder from the right side of the treadmill (Figure A).
- 4) Use a 6 mm Allen wrench to remove one screw and take off the plastic hand rail (Figure B).



FIGURE A



FIGURE B

- 5) Remove the 5 Phillips screws and remove the right side upper plastic cover (Figures C, D, & E).



FIGURE C



FIGURE D



FIGURE E

- 6) Cut the wire ties and begin to unthread the console cable (Figures F & G).



FIGURE F



FIGURE G

9.13 CONSOLE MAST ARM REPLACEMENT - CONTINUED

- 7) Remove the screws holding the console frame to the mast arms with a 6 mm Allen wrench in the openings with arrows (Figure H).
- 8) Lift the frame from the mast arms and set it aside (Figure I).



FIGURE H



FIGURE I

- 9) Use a 6 mm Allen wrench to remove the lower mast arm mounting screws (Figure J).
- 10) Pull the mast arm from the side of the machine (Figure K).

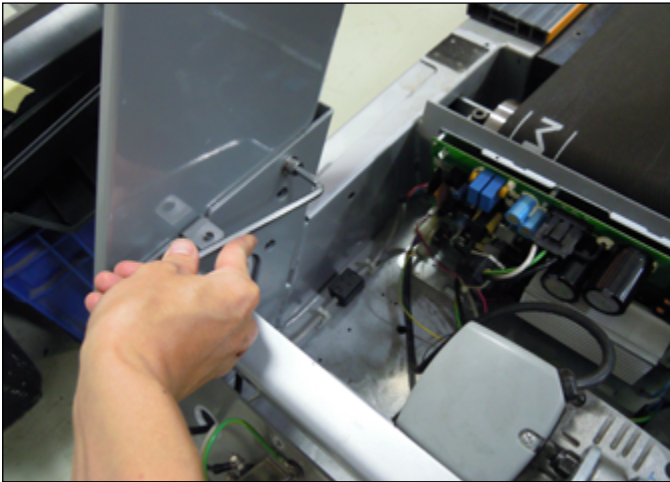

FIGURE J



FIGURE K

- 11) Reverse Steps 1-10 to install a new console mast. **NOTE:** If replacing the right side mast arm, the console cable must be threaded through it prior to it being mounted to the frame.

9.14 CONSOLE CABLE REPLACEMENT

- 1) Turn off power and disconnect the cord from the machine.
- 2) Remove the console as outlined in Section 9.12.
- 3) Take off the cup holder from the right side of the treadmill (Figure A).
- 4) Use a 6 mm Allen wrench to remove one screw and take off the plastic hand rail (Figure B).



FIGURE A



FIGURE B

- 5) Remove the 5 Phillips screws and remove the right side upper plastic cover (Figures C, D, & E).



FIGURE C



FIGURE D



FIGURE E

9.14 CONSOLE CABLE REPLACEMENT

6) Cut the wire ties and begin to unthread the wire harness (Figures F & G).



FIGURE F



FIGURE G

7) Remove the spiral protective wrap from the top and bottom portions of the wire harness (Figures H & I).



FIGURE H



FIGURE I

9.14 CONSOLE CABLE REPLACEMENT - CONTINUED

- 8) Attach a pulling wire to the top of the defective console cable (Figure J).
- 9) Slowly remove the defective console cable starting at the bottom of the machine and pulling it down to the motor compartment (Figure K).



FIGURE J



FIGURE K

- 10) Connect the new console cable at the motor tray - 3 connections total. Figures L & M show 2 of these connections, the 3rd is the coax cable.

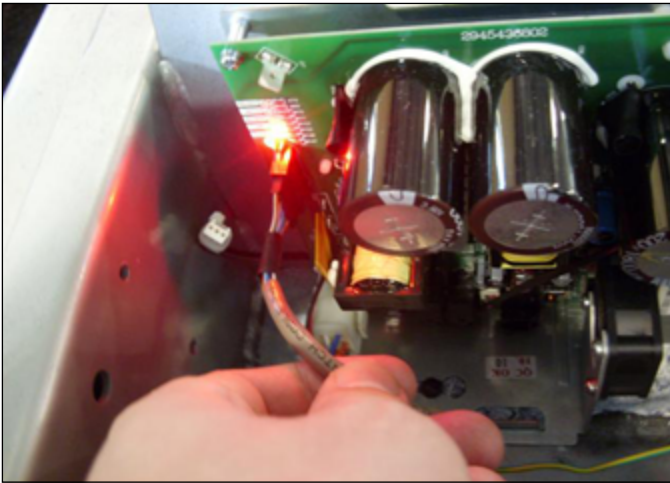

FIGURE L



FIGURE M

- 11) Attach the new console cable to the pulling wire and gently pull the new cable up through the machine. **NOTE:** Once the wire is in place, reinstall the spiral wrap and wire ties.
- 12) Reverse Steps 1-7 to finish installing a new console cable.
- 13) Auto Calibration must ALWAYS be run after the installation of a new console cable (see Section 3.4).

9.15 HANDLE BAR SERVICE

- 1) Turn off power and disconnect the cord from the machine.
- 2) All items on the handle bar are removed using a Phillips screwdriver from the underside of the bar.
- 3) Once the screws are removed, lift the part carefully and disconnect any wire connections.
- 4) Replace parts as needed on handle bar including the Quick Start Key and the Heart Rate Grip Plates (Figures A-F).



FIGURE A



FIGURE B

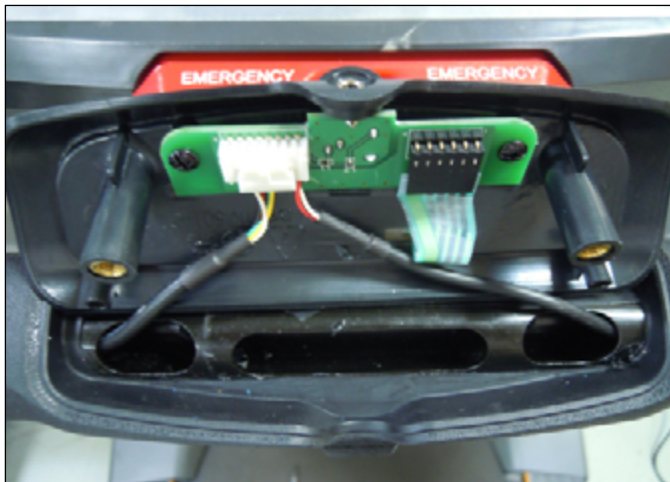

FIGURE C



FIGURE D



FIGURE E



FIGURE F

9.16 EMERGENCY STOP SWITCH REPLACEMENT

- 1) Turn off power and disconnect the cord from the machine.
- 2) Remove the console as outlined in Section 9.12.
- 3) Use a Phillips screwdriver to remove two screws, one from each side of the red button (Figure A).
- 4) Lift the button from bracket by pulling one side out at a time (Figure B).



FIGURE A



FIGURE B

- 5) Use a Phillips screwdriver to remove two screws, one from each side of the mounting bracket (Figure C).



FIGURE C

- 6) Turn the bracket and use a straight screwdriver or pliers to compress each end of the switch and release it from the bracket (Figures D & E).

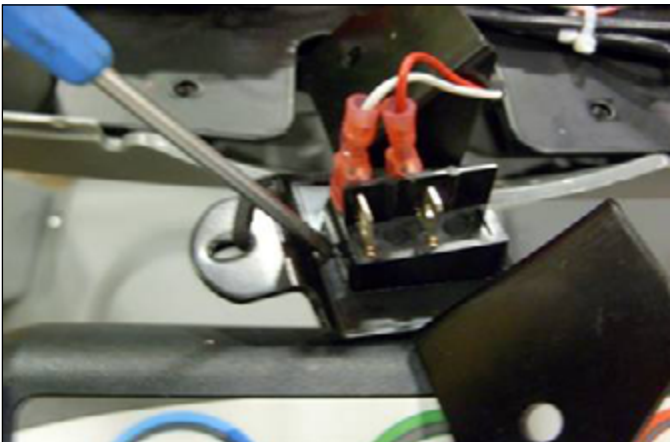

FIGURE D



FIGURE E

- 7) Reverse Steps 1-6 to install a new emergency stop switch. **NOTE:** Make sure the new switch has the same orientation as the old one when installing, and that the wires are properly connected.

9.17 HEART RATE BOARD REPLACEMENT

- 1) Turn off power and disconnect the cord from the machine.
- 2) Remove the console as outlined in Section 9.12.
- 3) The Heart Rate Board is located in front of the red Emergency Stop button (Figure A).
- 4) Disconnect the wires from each side of the Heart Rate Board (Figure B).



FIGURE A



FIGURE B

- 5) Use a Phillips screwdriver to remove two screws, one from each side of the Heart Rate Board mounting bracket (Figure C).



FIGURE C

- 6) Reverse Steps 1-5 to install a new heart rate board. **NOTE:** Be sure to fully seat the wires on the new heart rate board and test the grips after the console is reinstalled.

9.18 BLOWER MOTOR REMOVAL

- 1) Turn off power and disconnect the cord from the machine.
- 2) Remove the console as outlined in Section 9.12.
- 3) Lay the console face down and remove the four screws using a Phillips screwdriver (Figure A).
- 4) The console shell will now separate. Use a Phillips screwdriver to remove the two screws holding the blower motor in place (Figure B).



FIGURE A

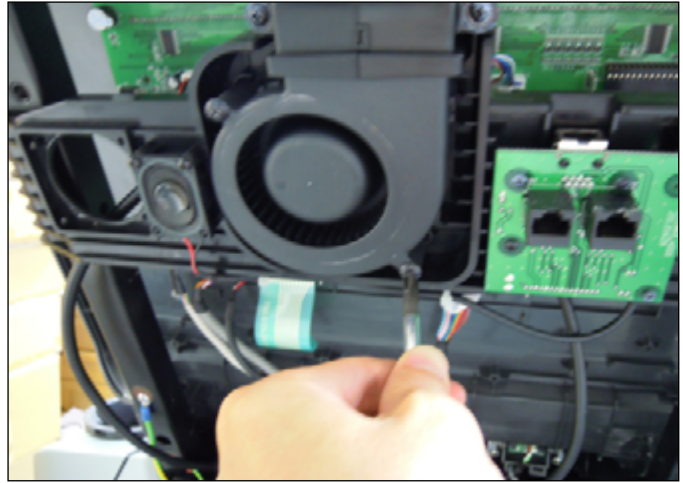

FIGURE B

- 5) Carefully separate the blower motor from the duct and remove it (Figure C).
- 6) Unplug the wire connections from the main circuit board to completely split the front and rear sections (Figure D).

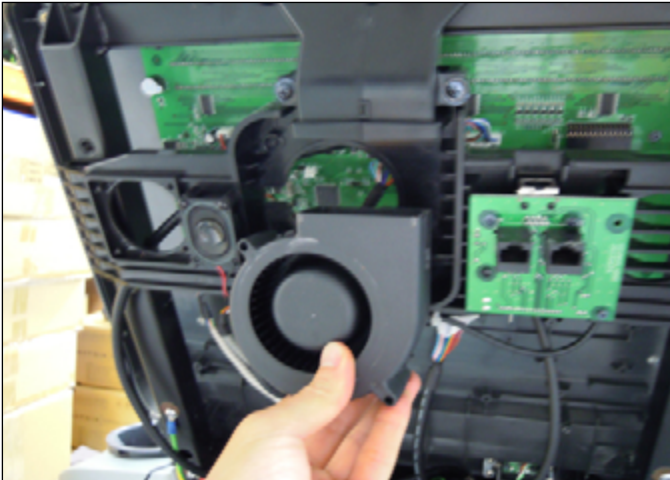

FIGURE C

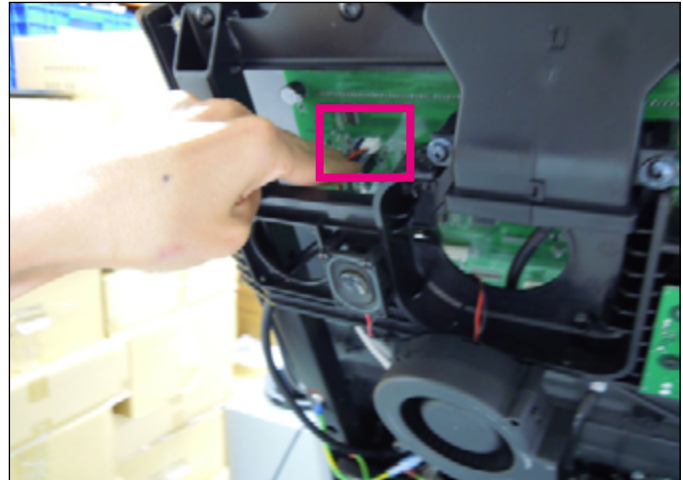

FIGURE D

- 7) Reverse Steps 1-6 to install a new blower motor. **NOTE:** Be sure to test the blower motor once the console is reinstalled.

9.19 OVERLAY REPLACEMENT

NOTE: The instructions below are similar for console overlays / keypads replacement, but the procedure is the same regardless of where the overlay / keypad.

- 1) Turn off power and disconnect the cord from the machine.
- 2) Remove the console as outlined in Section 9.12.
- 3) Remove the back cover of the console (Figure A).
- 4) Unplug and remove the faulty overlay (Figure B).



FIGURE A

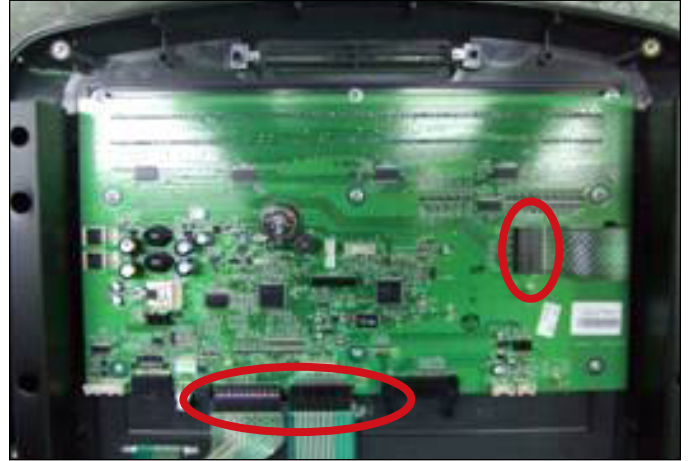

FIGURE B

- 5) Clean the console area with alcohol to remove any left over adhesive (Figure C).



FIGURE C

- 6) Remove the protective film over the display window of the overlay (Figure D).
- 7) Peel part of the protective film from the back of the overlay (Figure E).



FIGURE D



FIGURE E

9.19 OVERLAY REPLACEMENT - CONTINUED

- 8) Push the overlay ribbon cable through the hole in the console and plug it in (Figure F).
- 9) Match the overlay to the cutout on the console (Figure G).

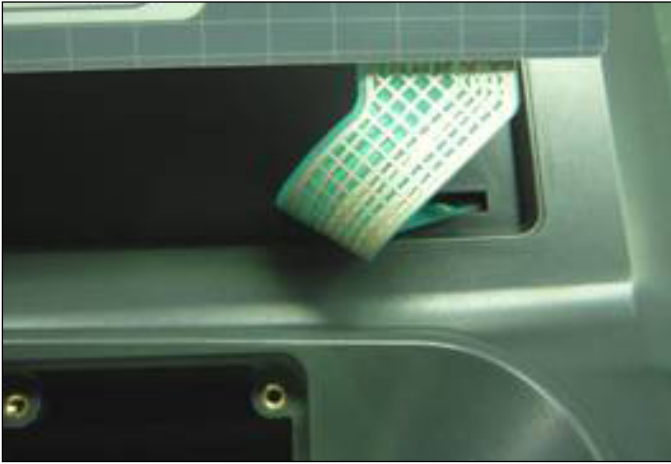

FIGURE F



FIGURE G

- 10) Press down on the corners of the overlay to keep it in place, then remove the protective film (Figure H & I).



FIGURE H



FIGURE I

- 11) Once the overlay is in the correct position, press down on the overlay with a cloth to adhere it to the console plastic (Figure J).



FIGURE J

- 12) Use the same procedure to replace any additional faulty overlays. **NOTE:** Overlays can not be reused.















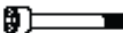

CHAPTER 10: TREADMILL SPECIFICATIONS AND ASSEMBLY GUIDE

10.1 TREADMILL SPECIFICATIONS

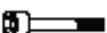
MODEL NAME	
TREADMILL TYPE	T5x TREADMILL
FRAME PART#	T-5X/7X-03-F
CONSOLE PART #	T-5X-07-C
FEATURES	
DECK TYPE	ULTIMATE™ HARD-WAX REVERSIBLE 1" DECK
BELT TYPE	HABASIT - 2-PLY COMMERCIAL GRADE
RUNNING AREA	60" X 22" / 152.4 CM X 55.9 CM
DECK STEP HEIGHT	9.5" / 24.1 CM
CUSHION SYSTEM	ULTIMATE DECK™ CUSHIONING SYSTEM
INCLINE RANGE	0-15% (1,300 LB / 589.7 KG THRUST INCLINE MOTOR)
SPEED RANGE	0.5 - 15* MPH / 0.8 - 24.1* KPH
CONTACT & TELEMETRIC HR SENSORS	YES
DRIVE SYSTEM	
MOTOR	MATRIX 5.0 HP AC DYNAMIC RESPONSE DRIVE SYSTEM™
MOTOR CONTROLLER	COMMERCIAL TREADMILL AC DRIVE
CONSOLE	
DISPLAY TYPE	DOT-MATRIX LED
DISPLAY FEEDBACK	TIME, TIME ELAPSED, TIME REMAINING, TOTAL PROGRAM TIME, CLOCK, DISTANCE (KILOMETERS OR MILES), CALORIES, CALORIES PER HOUR, SPEED, INCLINE, PACE, HEART RATE, METS, WATTS, STATIC PROFILE DISPLAY
USER DEFINED MULTI-LANGUAGE DISPLAY	YES- ENGLISH, GERMAN, FRENCH, ITALIAN, SPANISH, DUTCH, PORTUGUESE, JAPANESE, SWEDISH, FINNISH
WORKOUTS	MANUAL, ROLLING HILLS, FAT BURN, 5K, TARGET HR, GERKIN PROTOCOL, ARMY PFT, NAVY PRT, MARINE PFT, AIR FORCE PRT, PHYSICAL EFFICIENCY BATTERY (PEB), WFI PROTOCOL
CSAFE, FITLINXX READY	YES
NETPULSE READY	YES
ON-THE-FLY PROGRAM CHANGE	YES
FIT TOUCH TECHNOLOGY™	NO
INTEGRATED VISTACLEAR™ DIGITAL READY TELEVISION	NO
VIRTUAL ACTIVE™ COMPATIBLE	NO
FITCONNEXION™ READY	YES
WIFI	YES
ASSET MANAGEMENT COMPATIBLE	YES
IPOD COMPATIBLE	YES - CHARGING ONLY
NIKE + IPOD COMPATIBLE	NO
PERSONAL FAN	YES
CROSSBAR CONTROLS	GO, STOP, COOL DOWN, SPEED AND INCLINE CONTROL
TECH SPECS	
OVERALL DIMENSIONS L X W X H	84.6" X 33.7" X 58" 214.9CM X 85.6CM X 147.3CM
MAXIMUM USER WEIGHT	400 LBS/182 KG
WEIGHT	394 LBS/179 KG
SHIPPING WEIGHT	433 LBS/197 KG
ELECTRICAL RECEPTACLE & PLUG	NEMA 5-20R/P 110 V OR NEMA 6-20R/P 220 V
ELECTRICAL REQUIREMENTS	20 A DEDICATED CIRCUIT REQUIRED-NON-LOOPED-GROUNDED

CHAPTER 10: TREADMILL SPECIFICATIONS AND ASSEMBLY GUIDE

10.2 FASTENERS AND ASSEMBLY TOOLS

	Part #:	Part Name:	Outline:	Dimensions:	Quantity:	Bag Color:
10	020090-00	Socket head cap screw		M8 x 20mm	10	Black
14	0000086571	Flat Washer		6.2 x 12 x 1.6	10	Black
20	0000084935	Left Connection Bracket		SPHC 4.0T	1	
21	0000084936	Right Connection Bracket		SPHC 4.0T	1	
11	004541-AC	Socket Head Cap Screw		M8 x 1.25P x 45 mm	2	White
12	035882-AB	Socket Head Cap Screw		M8 x 1.25P x 75 mm	4	White
14	0000086571	Flat Washer		6.2 x 12 x 1.6T	6	White
17	004539-AD	Socket Head Cap Screw		M8 x 1.25P x 25mm	2	Blue
19	0000088905	Spacer		6.2 x 12.0 x 1.6	2	Blue
15	004859-AC	Button Socket Head Cap Screw		M8 x 1.25 x 20 mm	6	Red
14	0000086571	Flat Washer		6.2 x 12 x 1.6T	6	Red
13	020072-00	Socket Head Cap Screw		M8 x 1.25 x 60mm	4	Yellow
16	062769-00	Socket Head Cap Screw		M8 x 1.25 x 15mm	2	Yellow
23	0000089835	Ribbed Lock Washer		8.5 x 12.8 x .8/1.3H	6	Yellow
22	0000086284	Power Cord Holder		SPHC 1.6	1	Green
	002153-C	Power Cord			1	Green
18	004386-00	Button Head Screw		6.2 x 12.0 x 1.6T	2	Green

10.3 ASSEMBLY INSTRUCTIONS

ATTENTION

After assembly and installation is complete, the treadmill will need to be calibrated using the auto-calibration procedure outlined in Section 3.4. **DO NOT stand on the belt while the auto-calibration sequence is in progress.**

Prior to assembling the treadmill, unpack all of the contents of the box and make sure that all necessary components are present. Review the contents of the hardware package for completeness. Contact Matrix customer service at 866.693.4863 to report any missing items.

ASSEMBLY INSTRUCTIONS

Please make sure that the power cord is not plugged into the wall outlet while completing the following procedure.

To ensure correct assembly of the treadmill, carefully read and follow these steps:

STEP 1

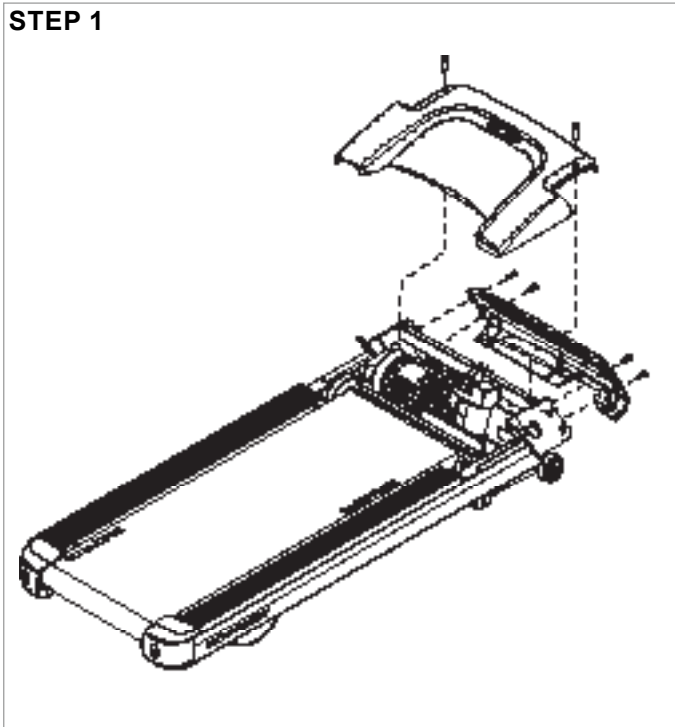

Remove the motor cover(s) and set aside. The motor cover(s) need to be removed to gain access to the motor compartment so that wire harness connections can occur.

STEP 2

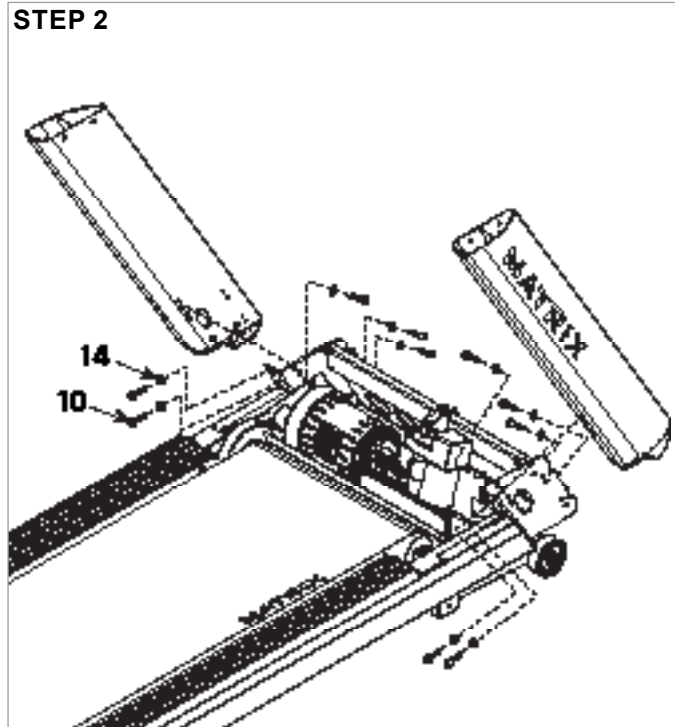

Open Black Assembly Bag. Assemble both the left and right console masts to the treadmill base using item 10 socket head cap screw and item 14 washer. Thread the console cable through the right console mast as you attach it.

10.3 ASSEMBLY INSTRUCTIONS - CONTINUED

STEP 3

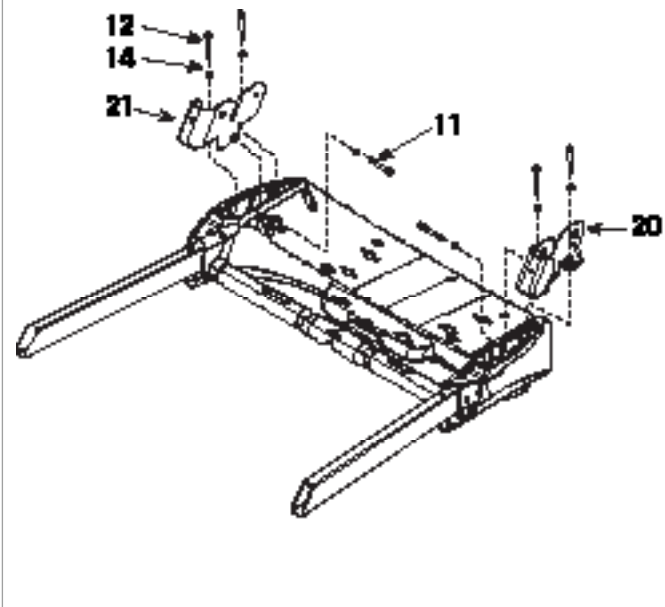

Open White Assembly Bag. Assemble the left and right bracket (items 20 and 21) to the console base using item 12 socket head cap screw, item 14 flat washer and item 11 socket head cap screw.

Assembly Tip: It is much easier to accomplish this task if the console base is left inside its shipping container.

STEP 4

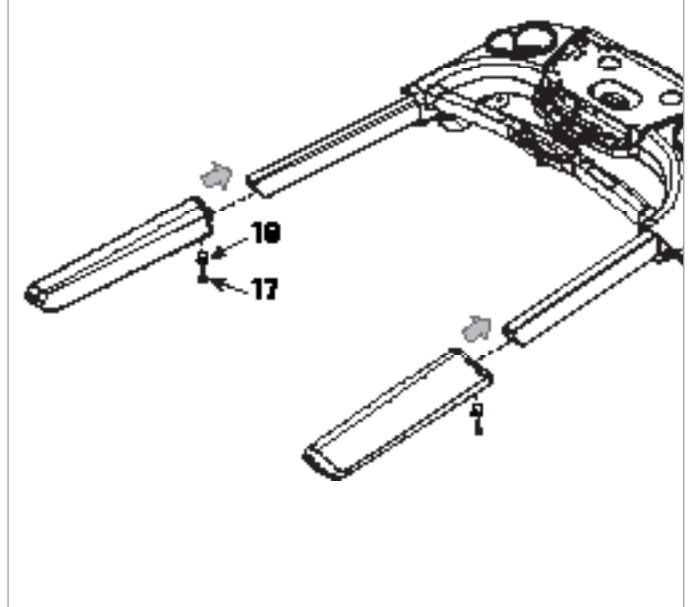

Open Blue Assembly Bag. Slide the urethane arms over the steel tubes on the console base. Fasten the urethane arms to the steel tubes using item 17 socket head cap screw and item 19 spacer.

10.3 ASSEMBLY INSTRUCTIONS - CONTINUED

STEP 5

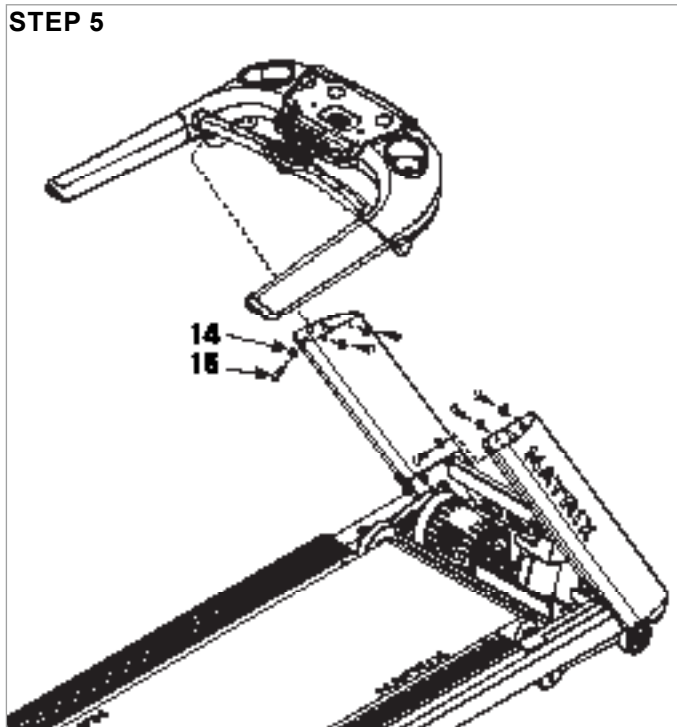

Open Red Assembly Bag. Assemble the console base to the console masts using item 15 button head cap screw and item 14 flat washer. Be sure to route the console cables down the console mast through the larger opening in the mast which is closest to the running belt. Make all appropriate wire connections within the motor compartment.

STEP 6

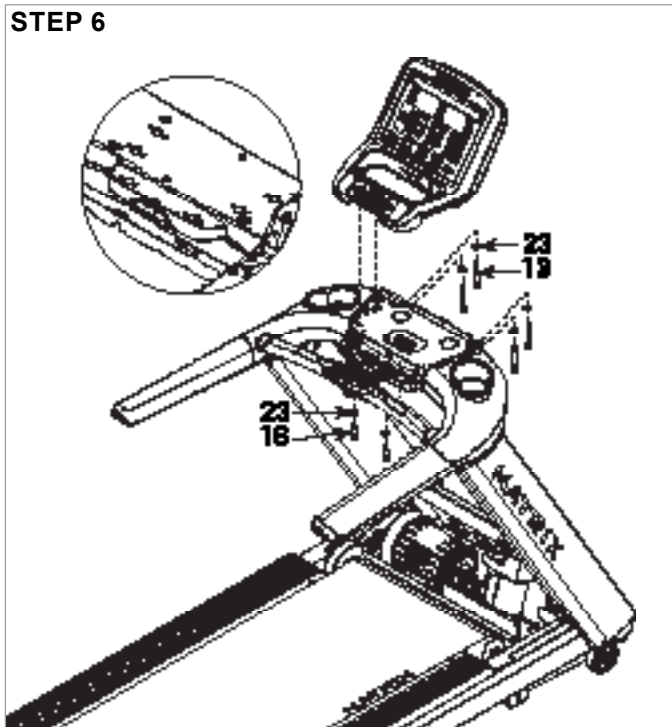

Open Yellow Assembly Bag. Make appropriate wire connections to the faceplate and then assemble to the console base using item 13 socket head cap screw, item 23 lock washers, and item 16 socket head cap screw. Item 16 is a shorter socket head cap screw and gets assembled into the holes closest to the running surface. All holes applicable to the assembly step can be noted by the embossed arrow next to the hole. See pages 69-70 for detailed instructions on wire connections.

10.3 ASSEMBLY INSTRUCTIONS - CONTINUED

STEP 7

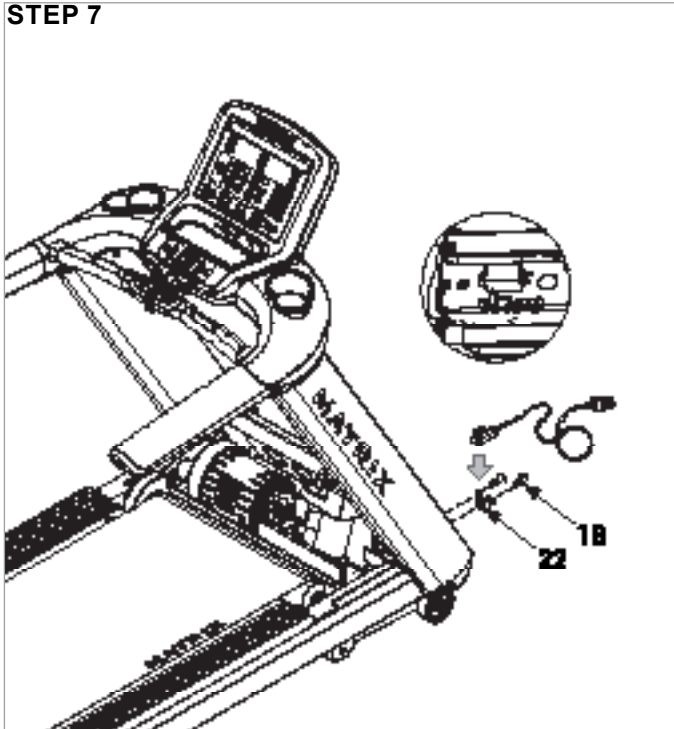

Open Green Assembly Bag. Install the power cord and assemble item 18 power cord holder with item 22 button head screw. If your hardware pack is missing item 22, check to see if the screws are already assembled on the treadmill.

STEP 8

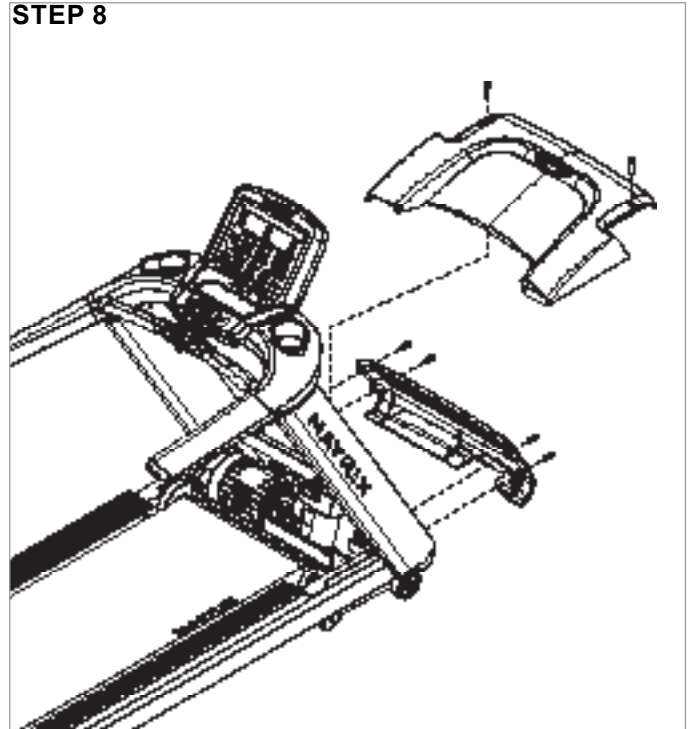

Replace the motor cover(s) and power the treadmill on. The power button is located next to the power cord inlet.

ASSEMBLY COMPLETE

Assembly is complete, the running belt should be adjusted as needed and the auto calibration sequence must now be run as outlined in Sections 3.4 and 3.5 Also level the unit as outlined in Section 10.5.

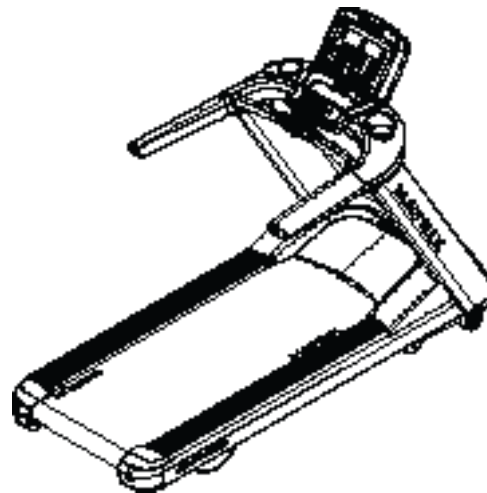

10.4 LEVELING THE TREADMILL

OPTIONAL LEVELING ASSEMBLY TECHNIQUES: USE OF SHIM OR BY ADDING A LEVELING FOOT.

Note: It is extremely important that the levelers are correctly adjusted for proper operation. An unbalanced unit may cause belt misalignment or other issues. Use of a level is recommended.

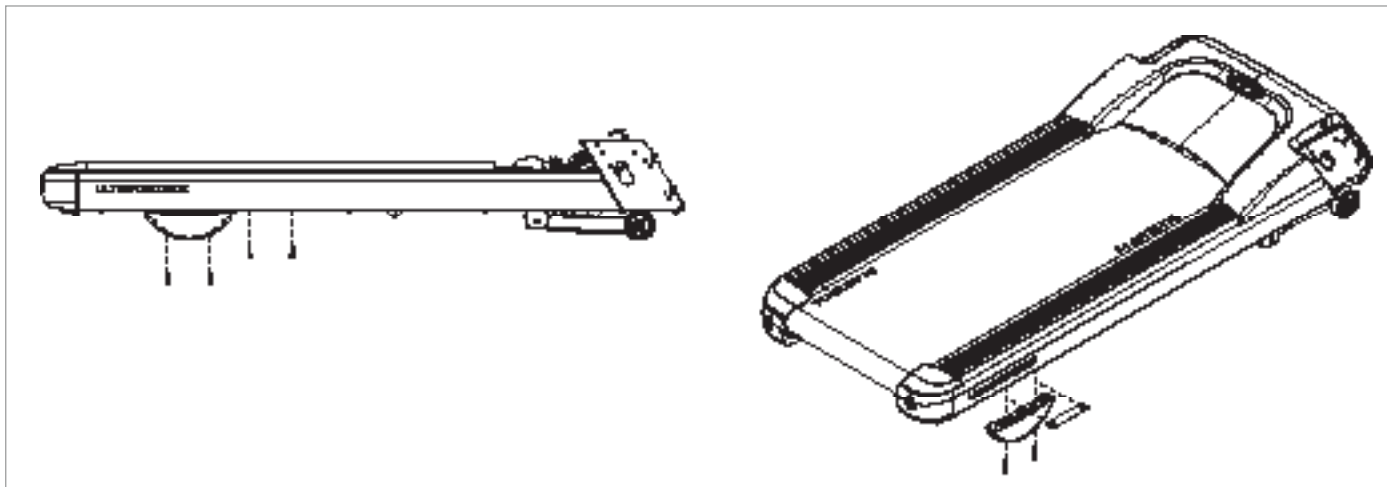

Remove the leveling shim provided on the underside of the treadmill. The shim can be found mounted on the underside of the right hand side rail. Remove the rear foot on the side of the treadmill that is resting low. Install the shim as shown above and return the rear foot.

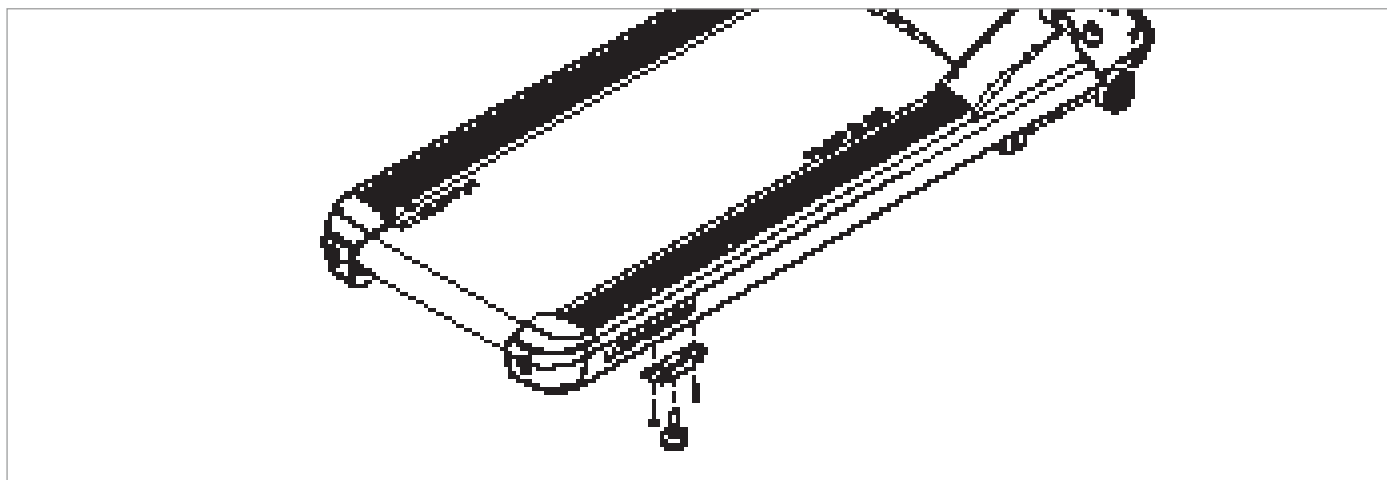

When installing the optional rear leveling foot accessory, remove the existing rear foot. Replace with new leveling foot and fasten to the frame using the existing fasteners that held in the half-moon foot.

11.1 SOFTWARE UPGRADE PROCEDURE

1. Create an access on USB folders which will be used. The access should be MATRIX\FW\UCB (create a folder called MATRIX, then a folder in MATRIX called FW, then a folder in FW called UCB). Or you can put USB in console and press ENTER, 9, 0, 0, 1, ENTER on the keypad and the USB will get the access. (Figure A)
2. Copy the software files into the UCB folder on the USB drive (the access should read \MATRIX\FW\UCB - Figure B).
3. Insert the USB drive into the USB port on the console (Figure C).
4. When the display is in standard condition, press ENTER, 9, 0, 0, 1, ENTER on the keypad. Press the LEVEL UP or DOWN keys to choose the correct software (if there are more than one versions on the USB drive). Once the correct software is found, press ENTER and the upgrade procedure will start.
5. If the console beeps and the standard display picture comes back up (Figure D), please remove the USB drive.

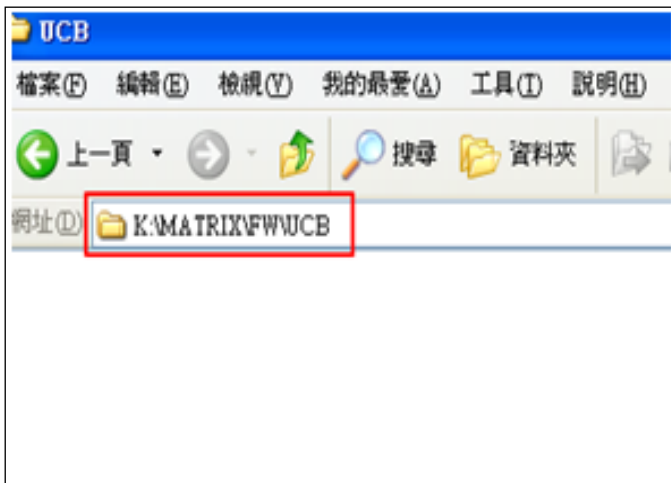

FIGURE A

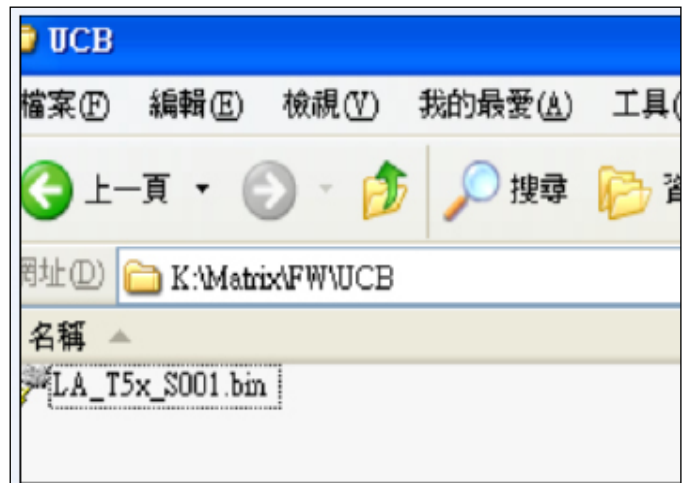

FIGURE B



FIGURE C



FIGURE D

NOTES

MATRIX

MATRIX FITNESS SYSTEMS CORP.
1610 LANDMARK DRIVE COTTAGE GROVE WI 53527 USA
TOLL FREE 866.693.4863 www.matrixfitness.com FAX 608.839.1717

REV. 01

KO