

FRENCH FITNESS

ASSEMBLY MANUAL

FF-X10LP (HG)

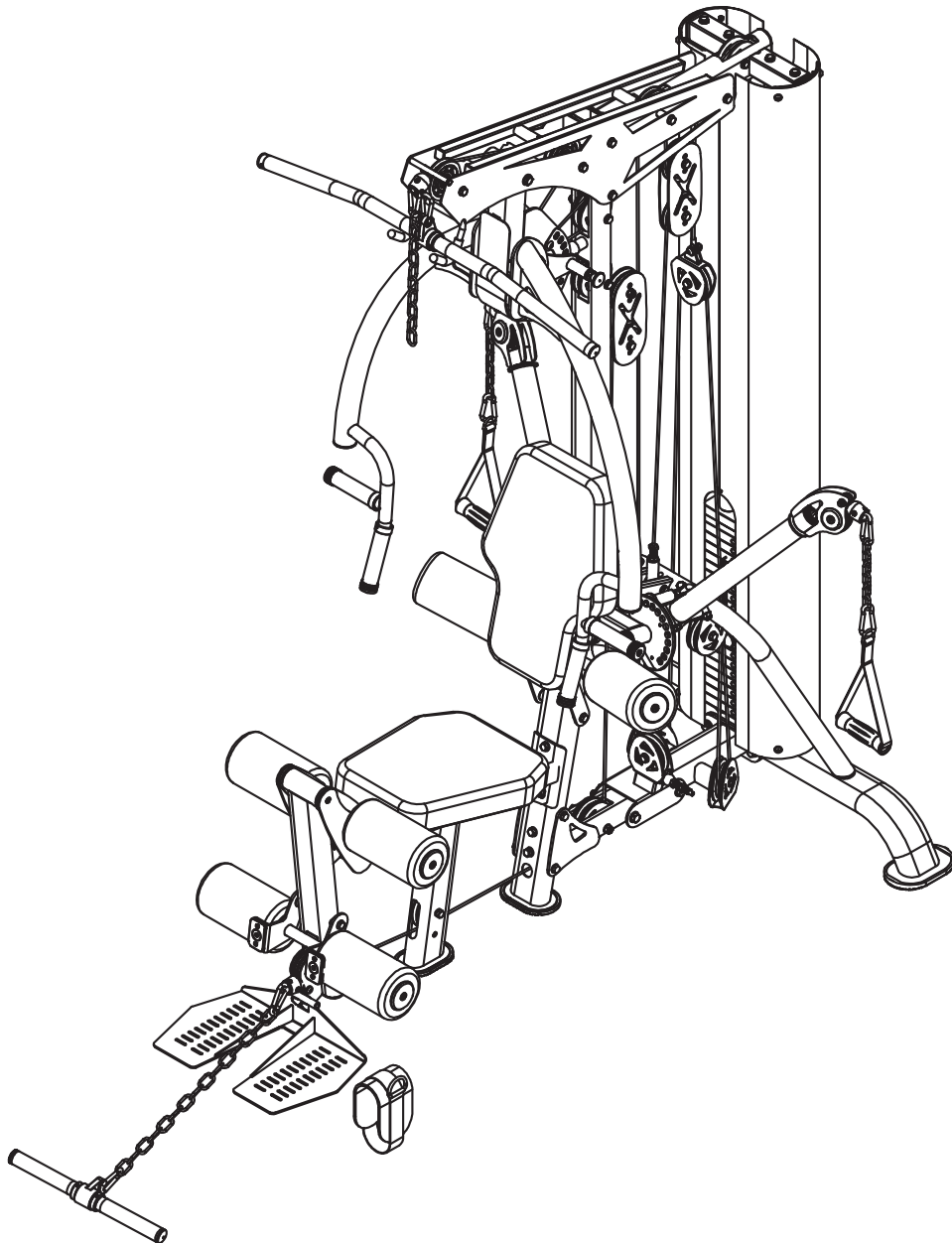

CAUTION!

Read all precautions and instructions in this manual before using this equipment.

20251030-V1.0

IMPORTANT SAFETY NOTICE

PRECAUTIONS

This exercise machine is built for optimum safety. However, certain precautions apply whenever you operate a piece of exercise equipment. Be sure to read the entire manual before you assemble or operate your machine. In particular, note the following safety precautions:

1. **Keep children and pets away from the machine at all times. DO NOT leave children unattended in the same room with the machine.**
2. Only one person at a time should use the machine.
3. If the user experiences dizziness, nausea, chest pain, or any other abnormal symptoms, STOP the workout at once. CONSULT A PHYSICIAN IMMEDIATELY.
4. Position the machine on a clear, leveled surface. DO NOT use the machine near water or outdoors.
5. Keep hands away from all moving parts.
6. Always wear appropriate workout clothing when exercising. DO NOT wear robes or other clothing that could become caught in the machine. Running or aerobic shoes are also required when using the machine.
7. Use the machine only for its intended use as described in this manual. DO NOT use attachments not recommended by the manufacturer.
8. Do not place any sharp object around the machine.
9. Disabled person should not use the machine without a qualified person or physician in attendance.
10. Before using the machine to exercise, always do stretching exercises to properly warm up.
11. Never operate the machine if the machine is not functioning properly.

WARNING: BEFORE BEGINNING ANY EXERCISE PROGRAM, CONSULT YOUR PHYSICIAN. THIS IS ESPECIALLY IMPORTANT FOR INDIVIDUALS OVER THE AGE OF 35 OR PERSONS WITH PRE-EXISTING HEALTH PROBLEMS. READ ALL INSTRUCTIONS BEFORE USING ANY FITNESS EQUIPMENT. WE ASSUMES NO RESPONSIBILITY FOR PERSONAL INJURY OR PROPERTY DAMAGE SUSTAINED BY OR THROUGH THE USE OF THIS PRODUCT.

SAVE THESE INSTRUCTIONS.

IMPORTANT ASSEMBLY INFORMATION

- ❖ Tools Required for Assembling the Bench: Adjustable Wrench and Allen Wrench.
- ❖ NOTE: It is strongly recommended that this equipment is assembled by two or more people to avoid possible injury.
- ❖ Ensure **Carriage Bolts** are inserted through the **SQUARE holes** on components that need to be assembled. Attach washer only to end of the Carriage Bolt.
- ❖ Use **Allen Bolts or Hex Bolts** inserted through the **ROUND hole** on components that need to be assembled.
- ❖ Always wait until all bolts are assembled onto the bench before tightening the bolts. Do not tighten each bolt right after it is installed

Fasten Nuts and Bolts

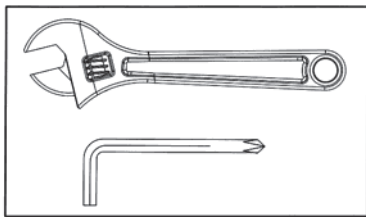

Securely tighten all Nuts and Bolts after all components have been assembled in current and previous steps.
NOTE: Do not over tighten any component with pivoting function.
Make sure all pivoting components are able to move freely.

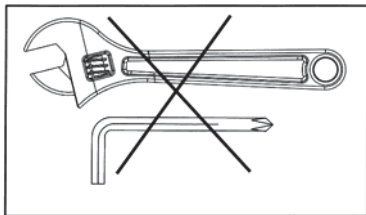

Do not tighten all Nuts and Bolts in this step.

Assembled Dimension: 1744mm x 1154mm x 2109mm

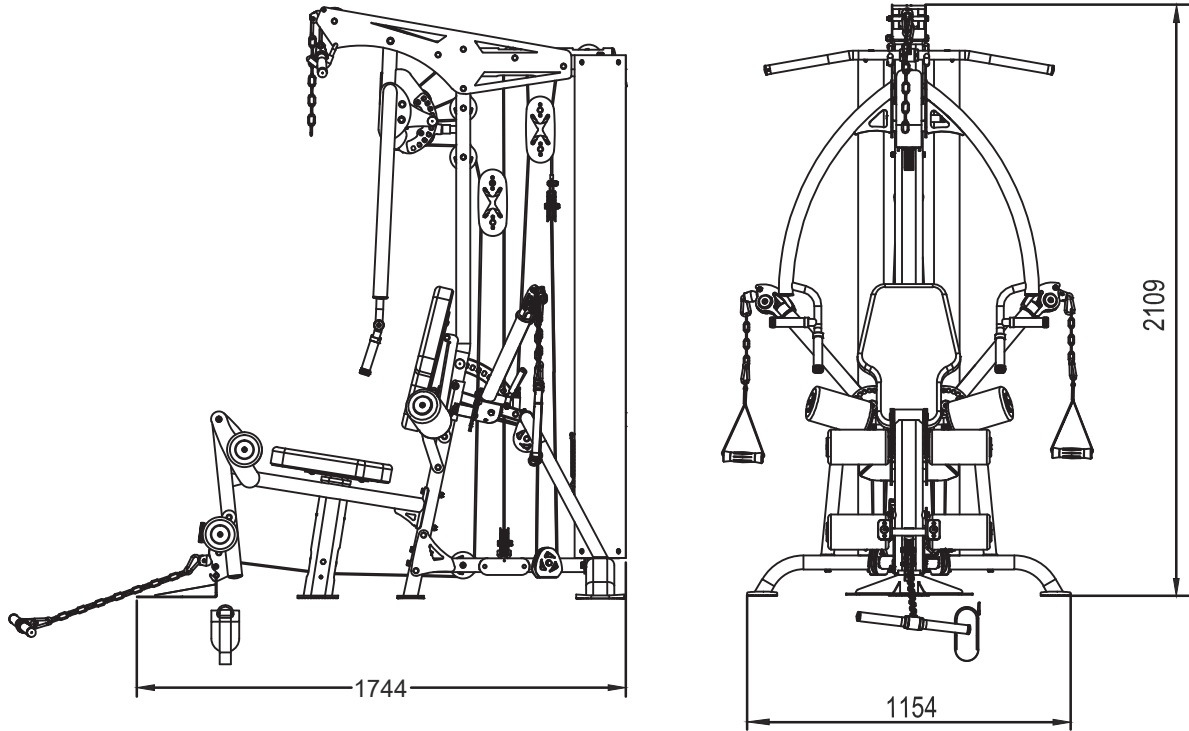

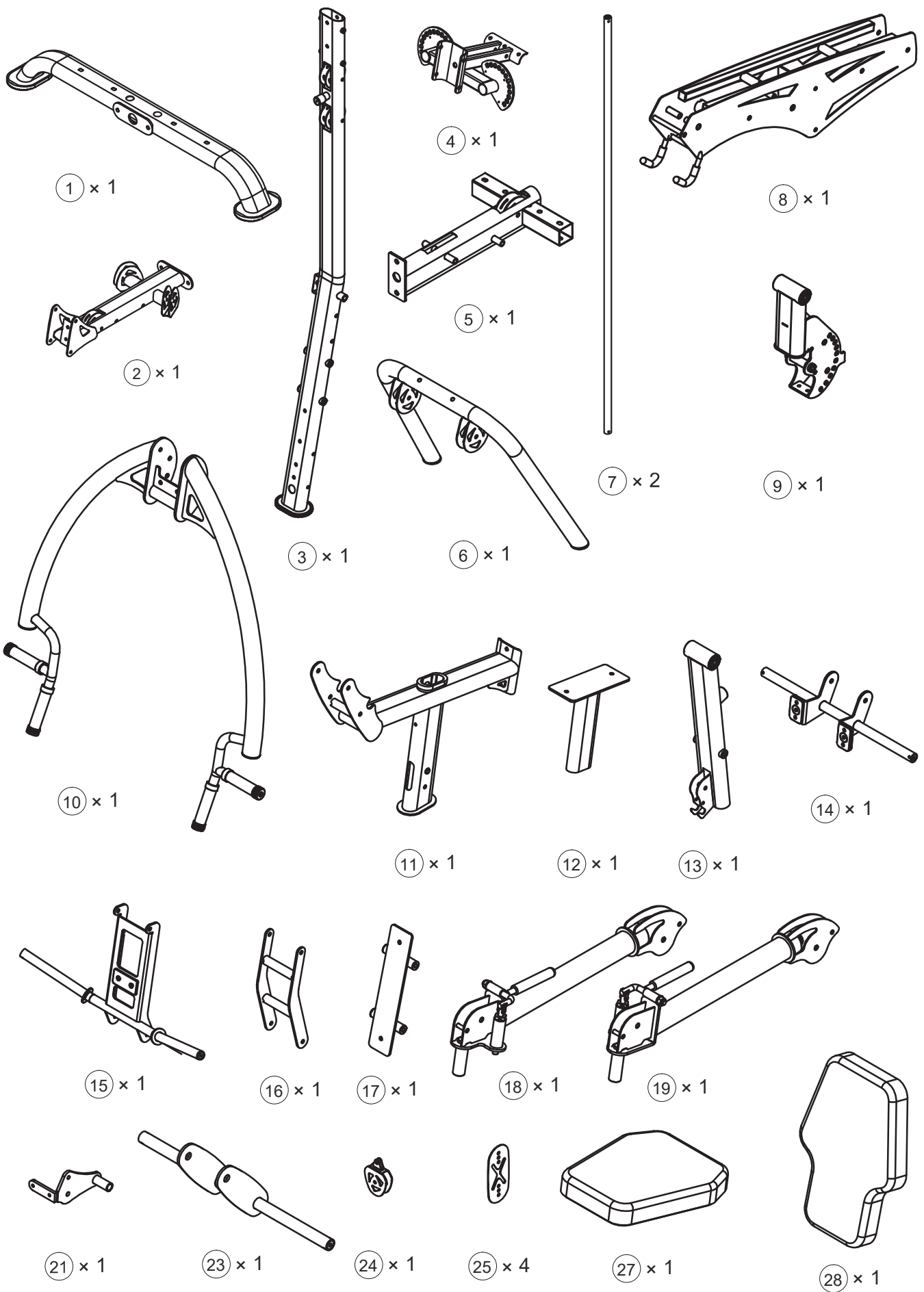

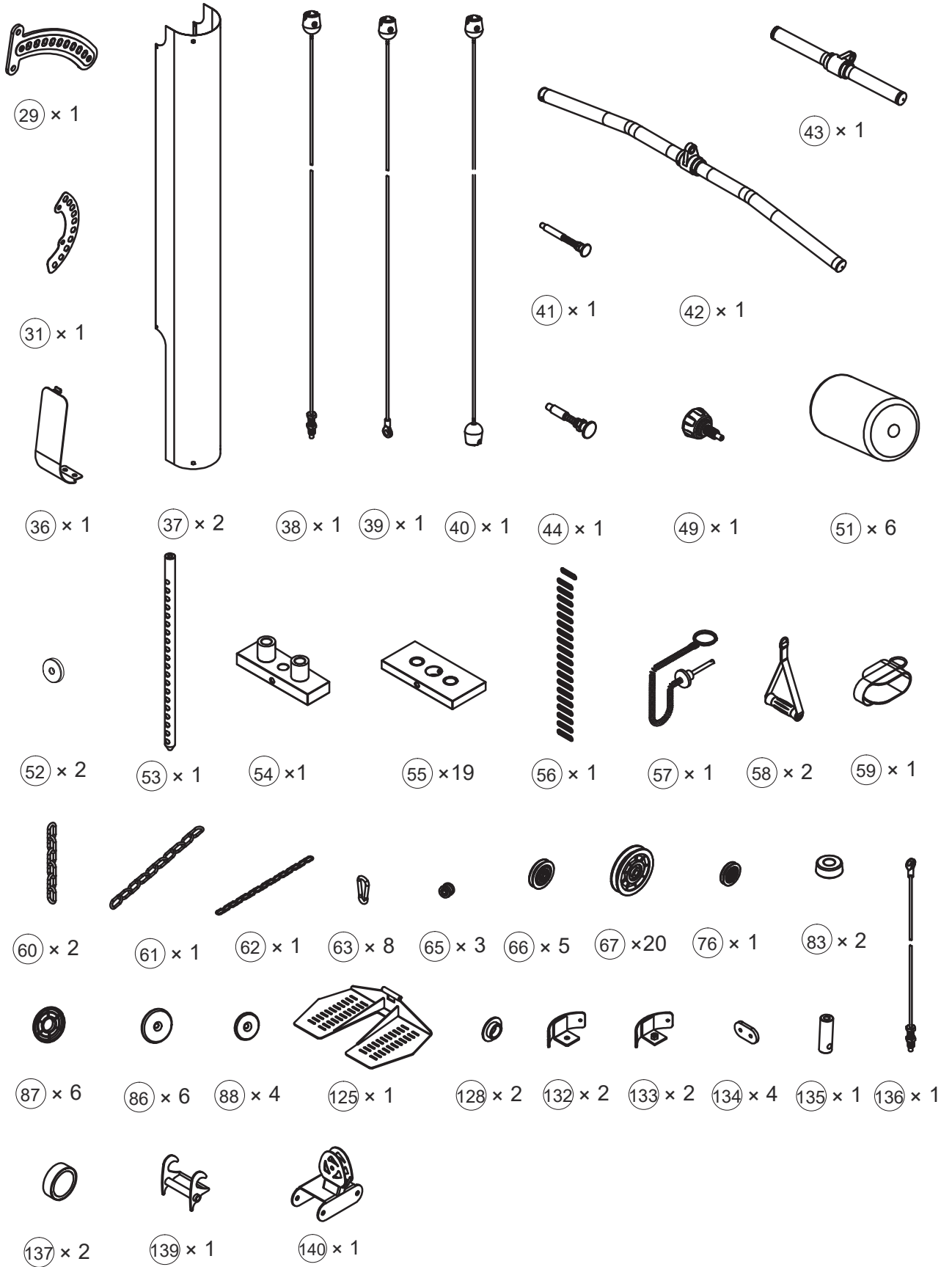

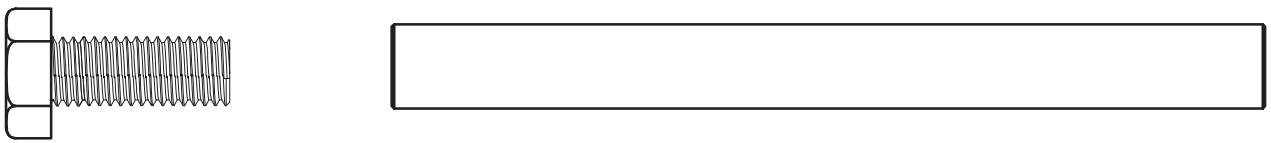

98 × 4

34 × 2

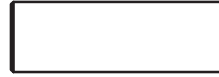
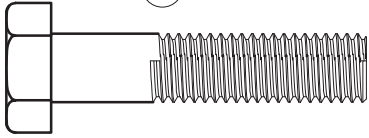

99 × 13

35 × 2

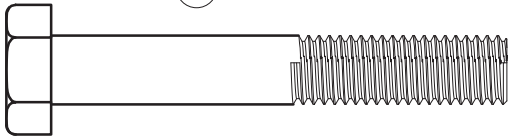

100 × 11

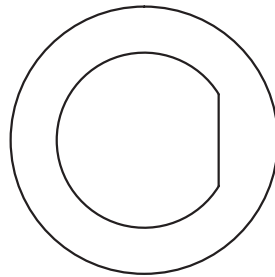
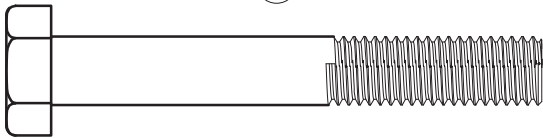

101 × 5

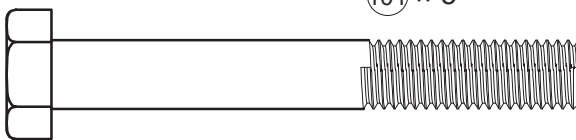

102 × 2

33 × 2

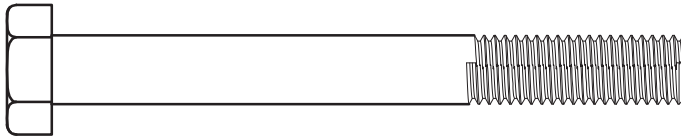

103 × 1

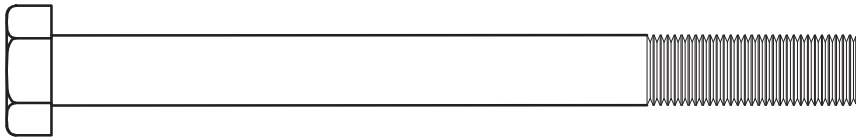

104 × 3

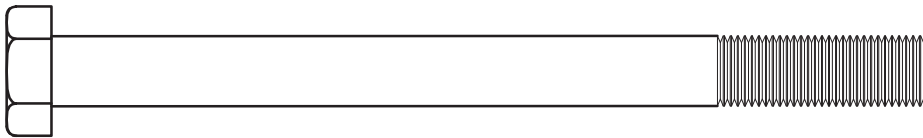

105 × 2

mm

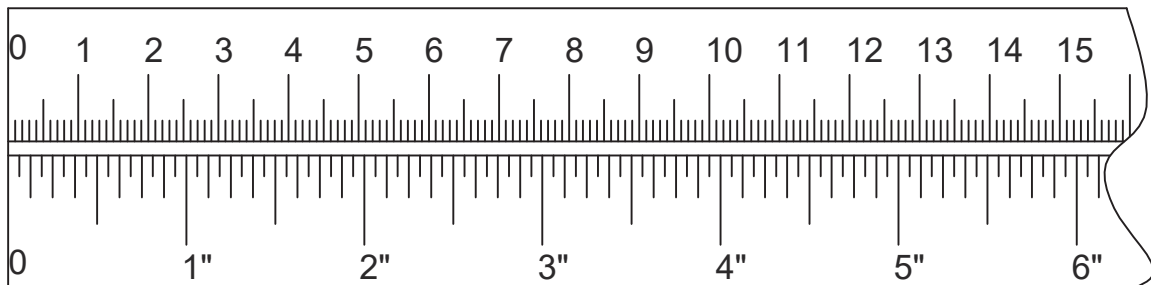

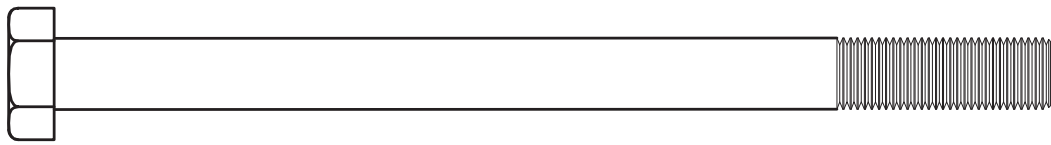

⑩⑥ × 6

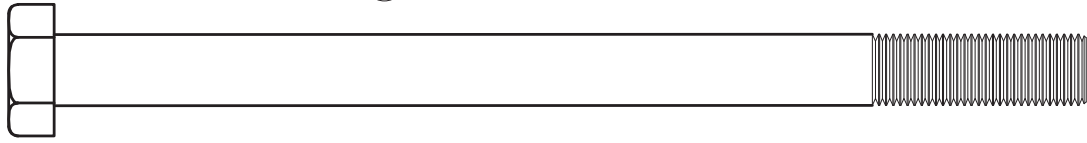

⑩⑦ × 5

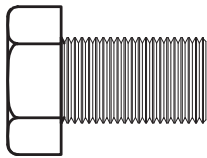

⑩⑧ × 1

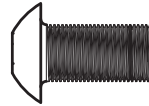

⑩⑫ × 8

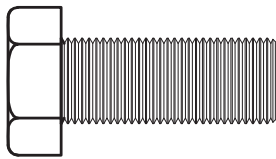

⑩⑨ × 2

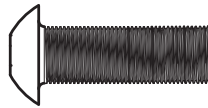

⑩⑬ × 6

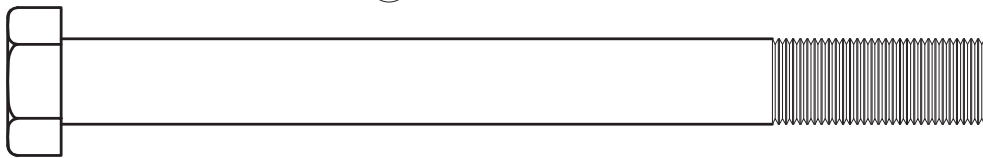

⑩⑩ × 2

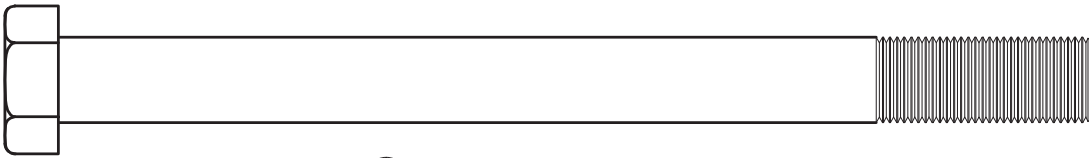

⑩⑪ × 2

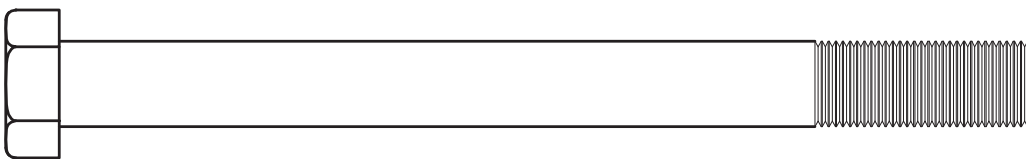

⑩⑭ × 2

mm

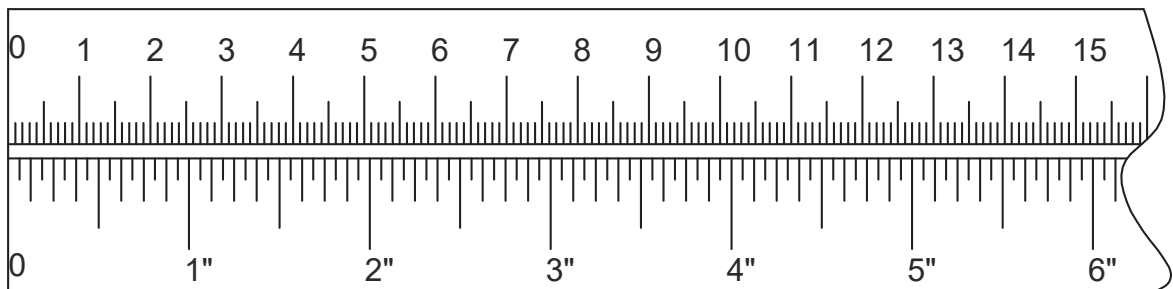

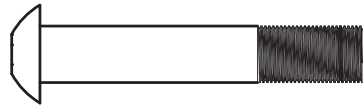

114 × 3



89 × 2

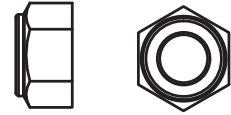

95 × 3

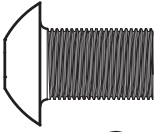

115 × 4

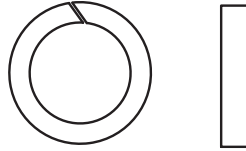

90 × 4

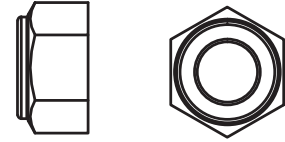

96 × 41

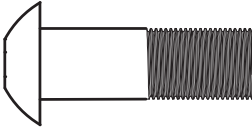

116 × 1

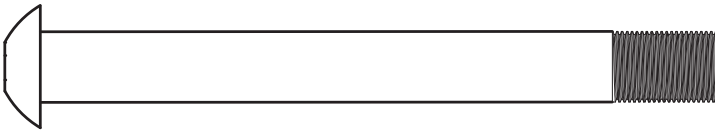

117 × 2

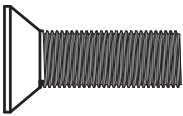

118 × 10



91 × 18

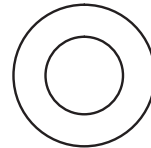

92 × 96



97 × 6



120 × 8

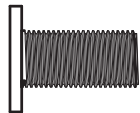

123 × 4

6# × 1

5# × 2

4# × 1

3# × 1

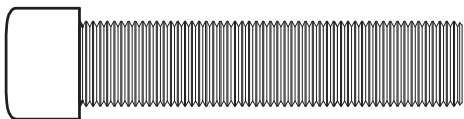

131 × 1

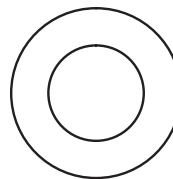

93 × 15



mm

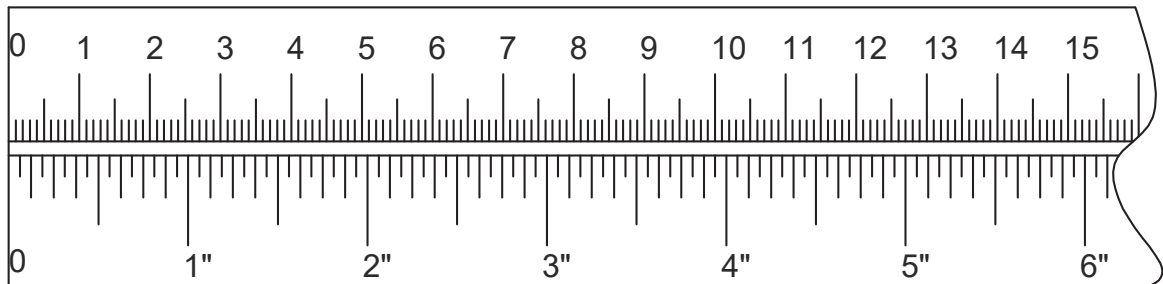

- | | | | | | | | | | | | |
|-------|--|----|---------|-------|--|----|--------|------|--|----|-----|
| (105) | | x2 | M10x125 | (90) | | x2 | Φ12 | (89) | | x1 | Φ10 |
| (101) | | x2 | M10x70 | (93) | | x2 | Φ12 | (92) | | x9 | Φ10 |
| (100) | | x2 | M10x65 | (109) | | x2 | M12x30 | (96) | | x3 | M10 |

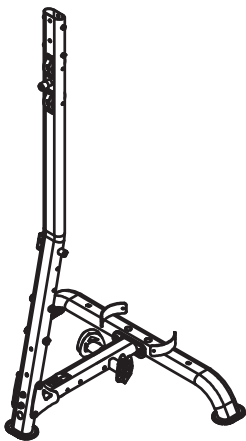
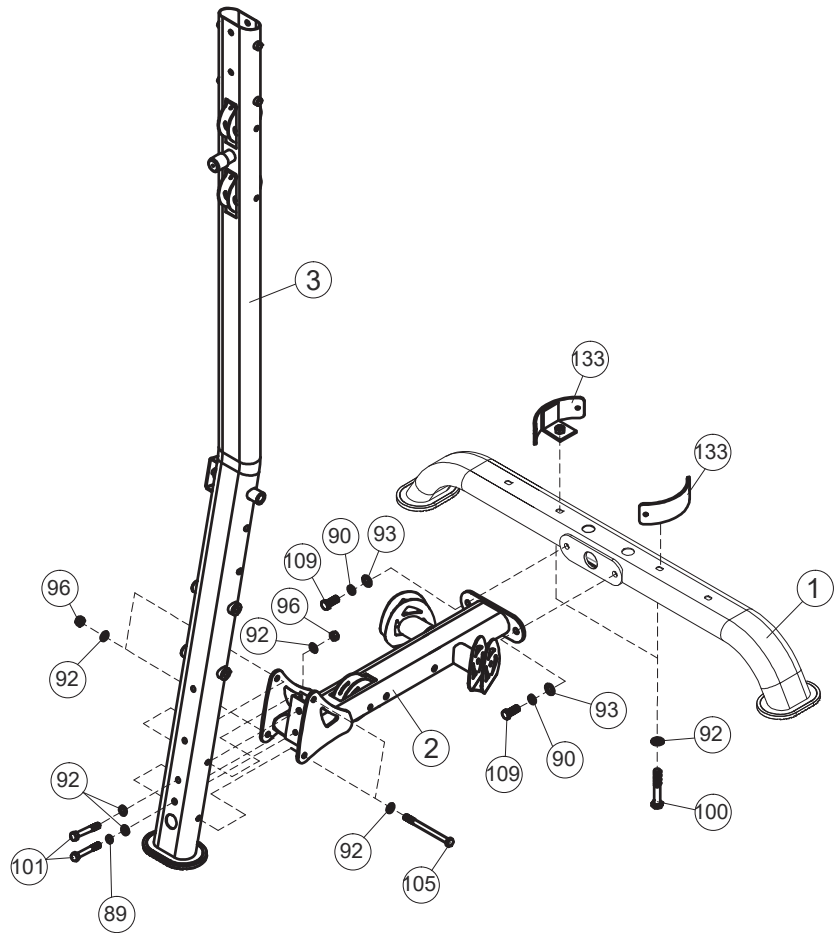
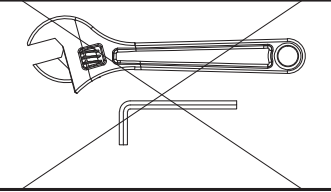

98  ×2 M10×25

92  | ×2 Φ10

131  ×1 M10×55

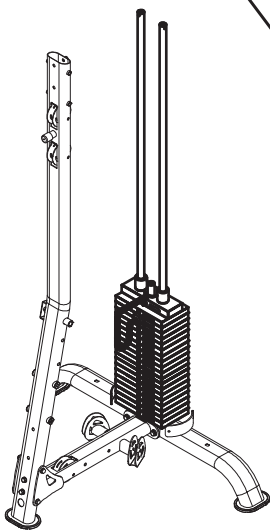
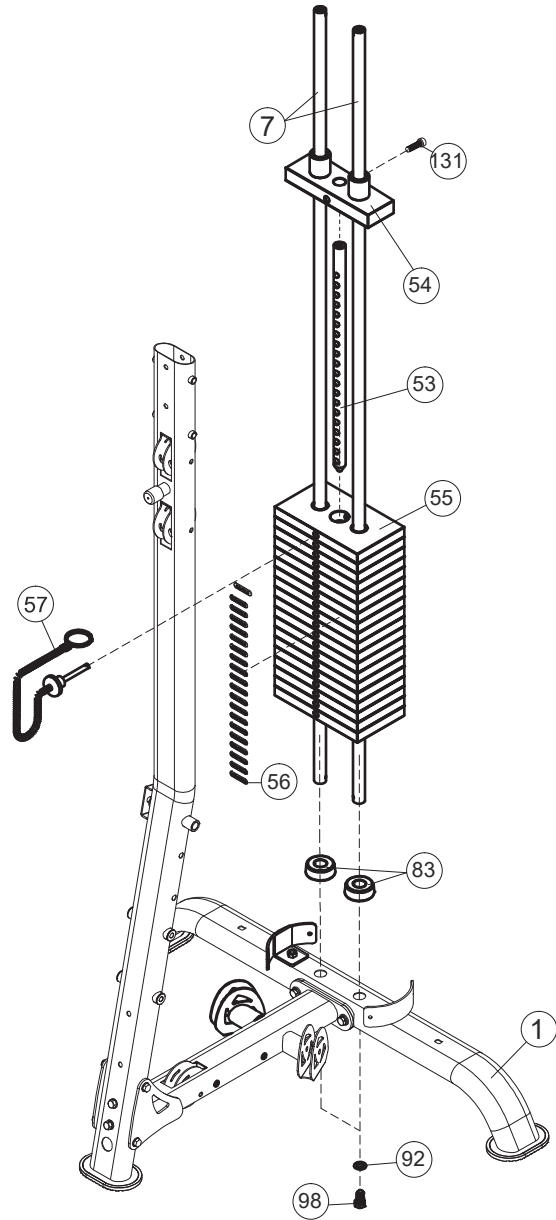
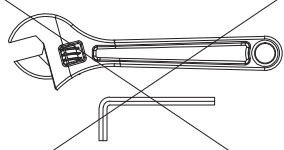

⑩⑥  ×2 M10×140

⑧⑨  | ×1 Φ10







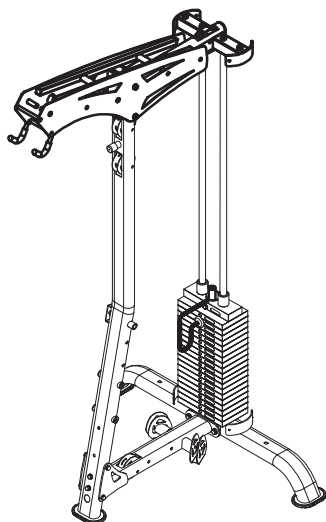
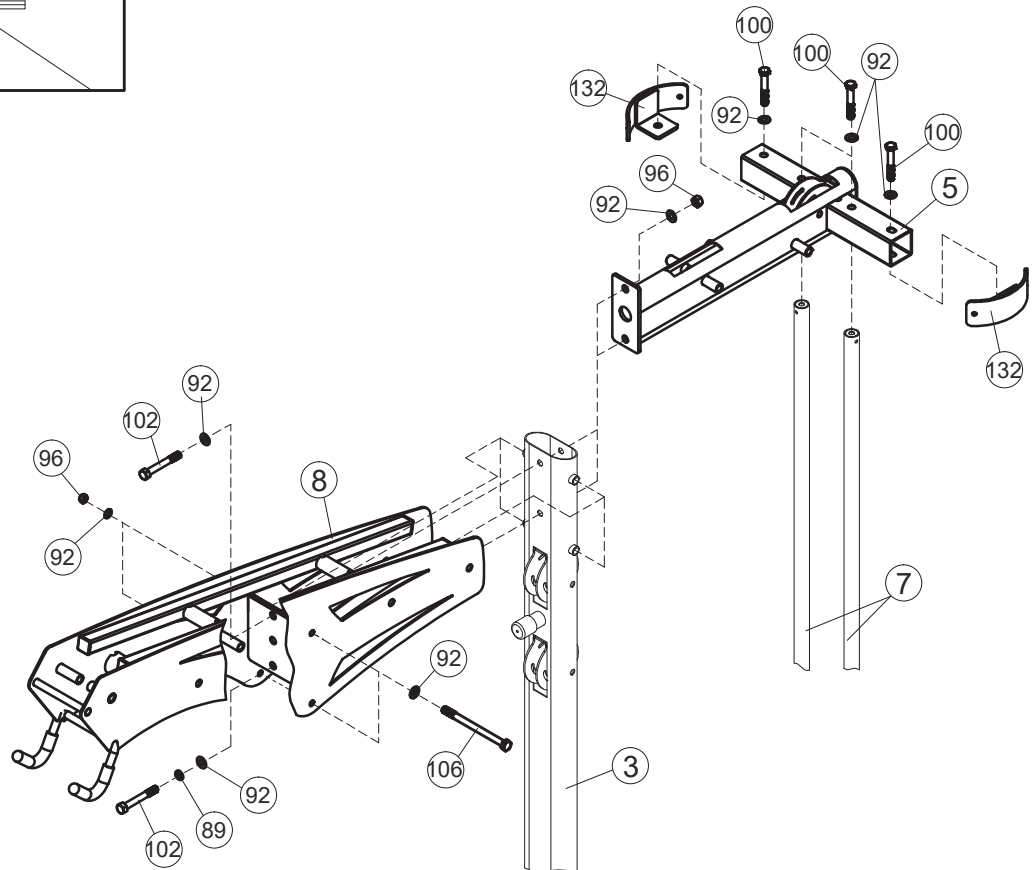
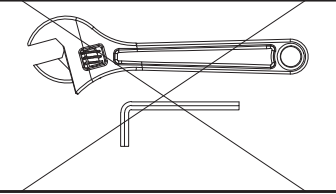

⑩②  ×2 M10×75

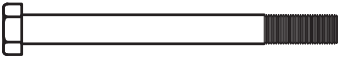
⑨②  | ×11 Φ10

⑩①  ×4 M10×65

⑨⑥   ×3 M10



- | | | | | | | | |
|-----|---|----|---------|----|---|----|-----|
| 110 |  | x2 | M12x130 | 92 |  | x6 | Φ10 |
| 100 |  | x4 | M10x65 | 33 |  | x2 | |
| 113 |  | x2 | M 8x25 | 96 |  | x2 | M10 |
| | | | | 97 |  | x2 | M12 |
| | | | | 93 |  | x4 | Φ12 |

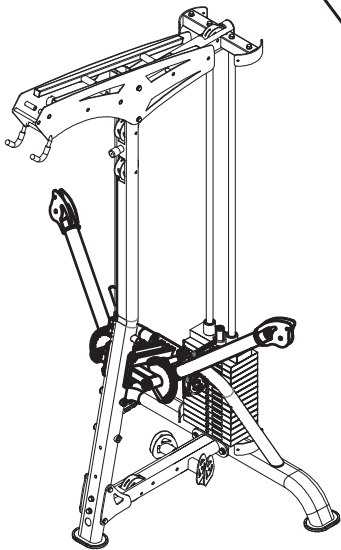
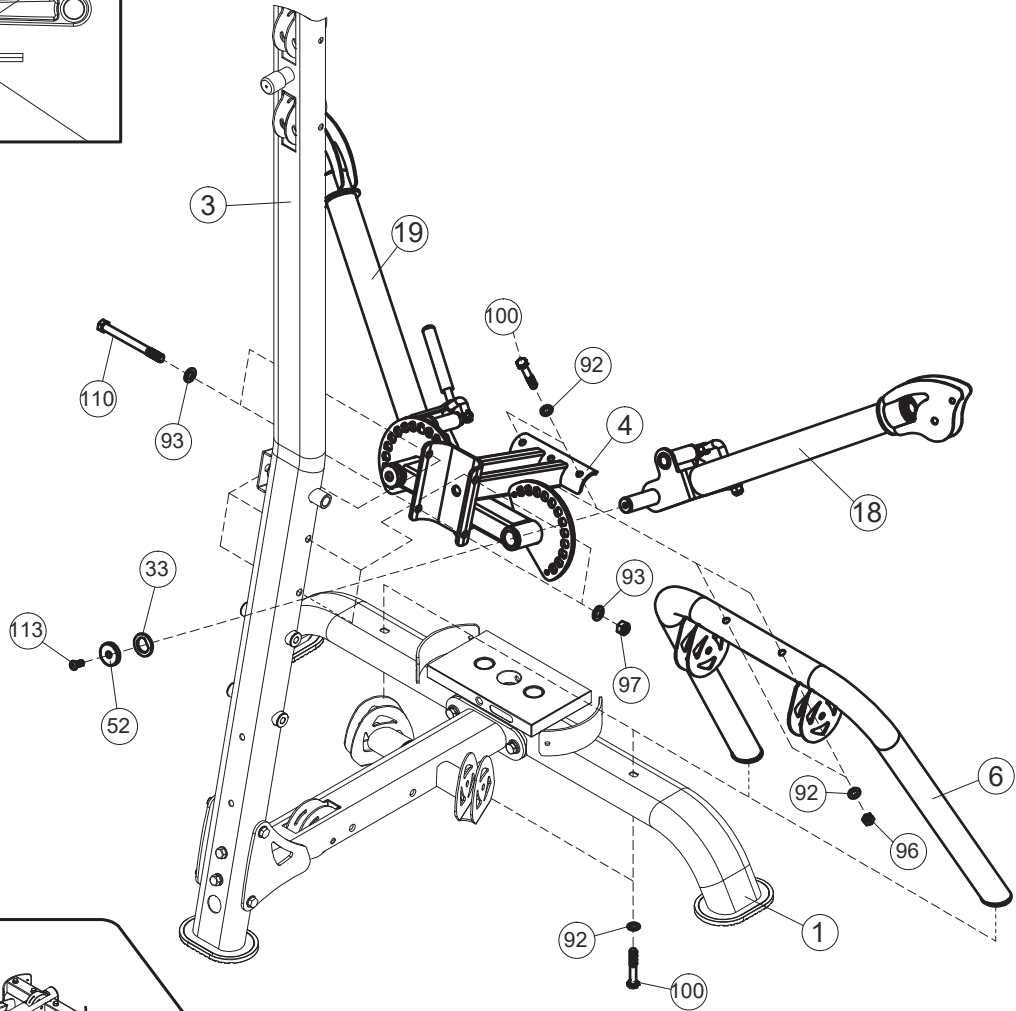
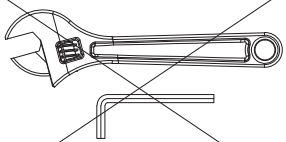

- (107) ×4 M10×145
(118) ×2 M 8×20
- (98) ×2 M10×25
(91) ×2 Φ 8
(92) ×12 Φ10
- (113) ×2 M 8×25
(96) ×6 M10

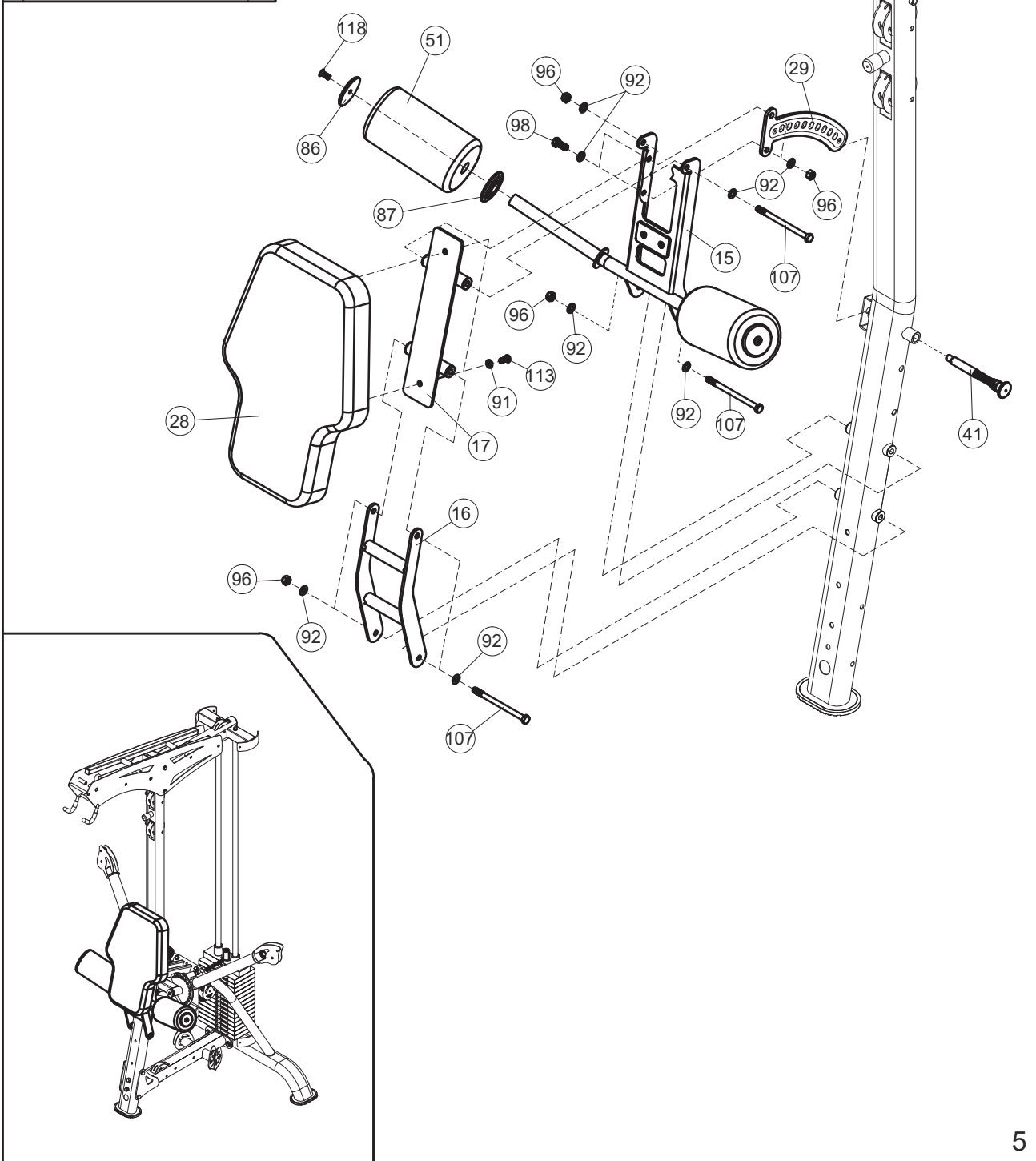
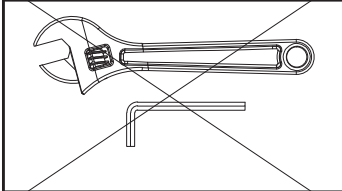

- | | | | | | | | | | | | |
|-----|--|----|---------|----|--|----|-----|----|--|----|-----|
| 111 | | x2 | M12x145 | 93 | | x5 | Φ12 | 90 | | x2 | Φ12 |
| 108 | | x1 | M12x20 | 97 | | x2 | M12 | 92 | | x4 | Φ10 |
| 115 | | x4 | M10x16 | | | | | | | | |

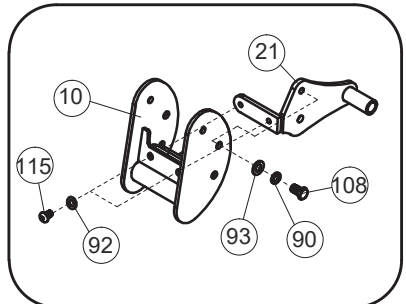
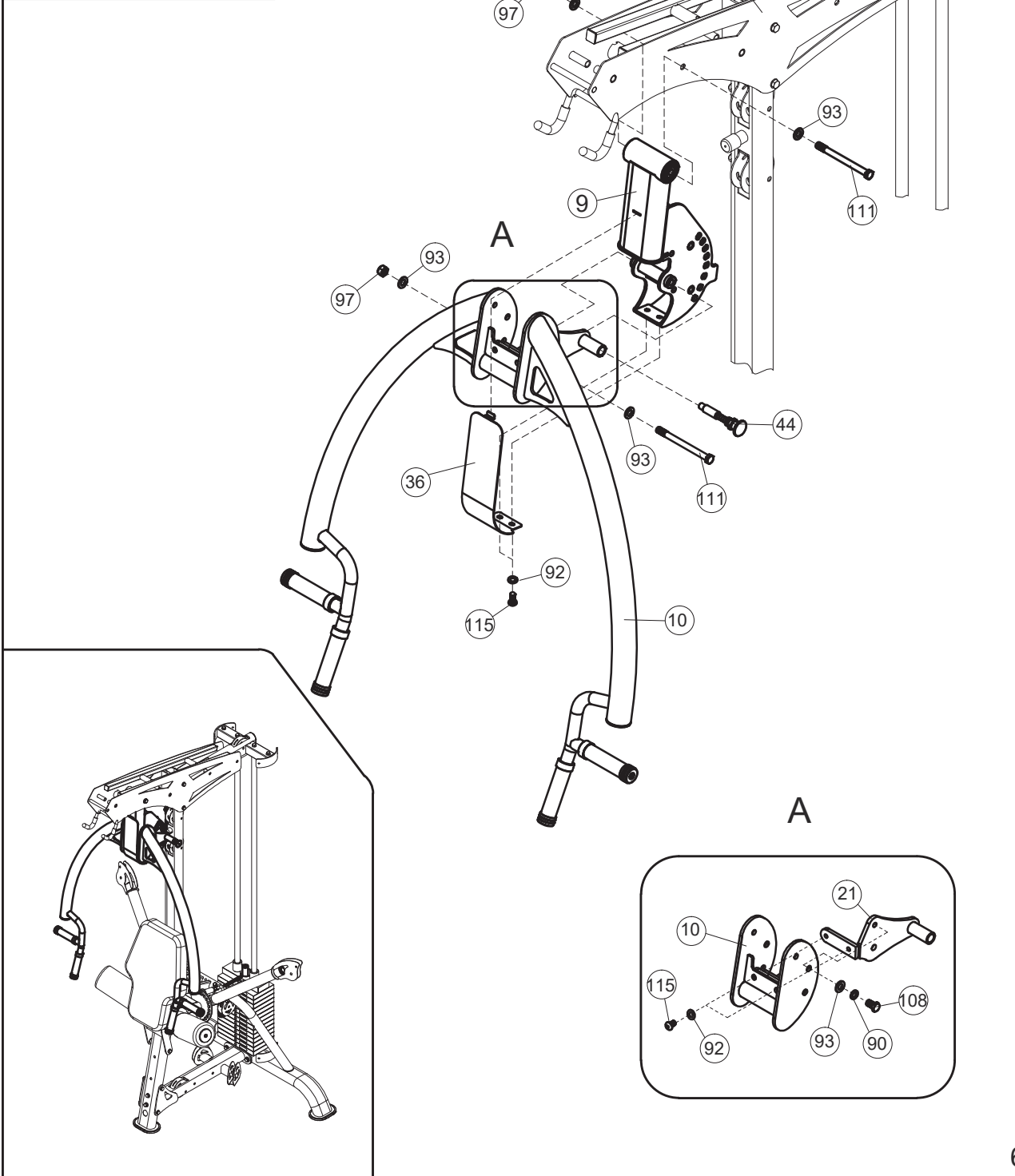
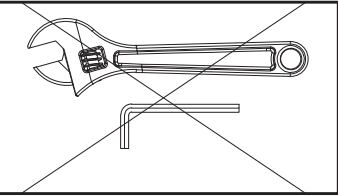

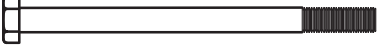
⑩⑦  ×1 M10×145

⑨②  | ×6 Φ10

⑩①  ×2 M10×70

⑨⑥   ×3 M10

⑩③  ×2 M 8×25

⑩②③  ×4 Φ20×M 8×12

⑨①  | ×2 Φ 8

⑩⑧  ×4 M 8×20

③④  ×2 Φ12×124×M8

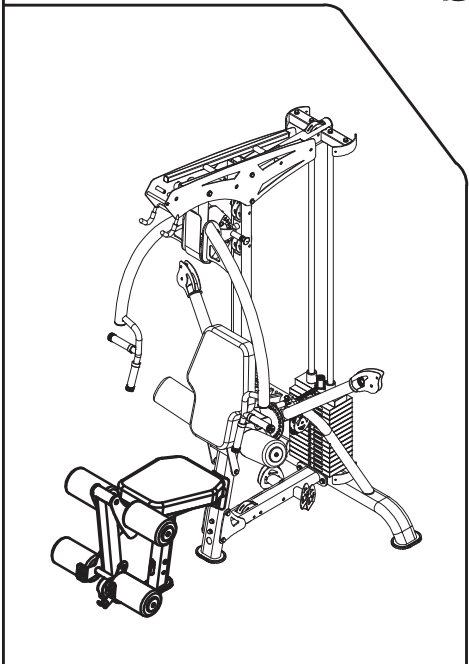
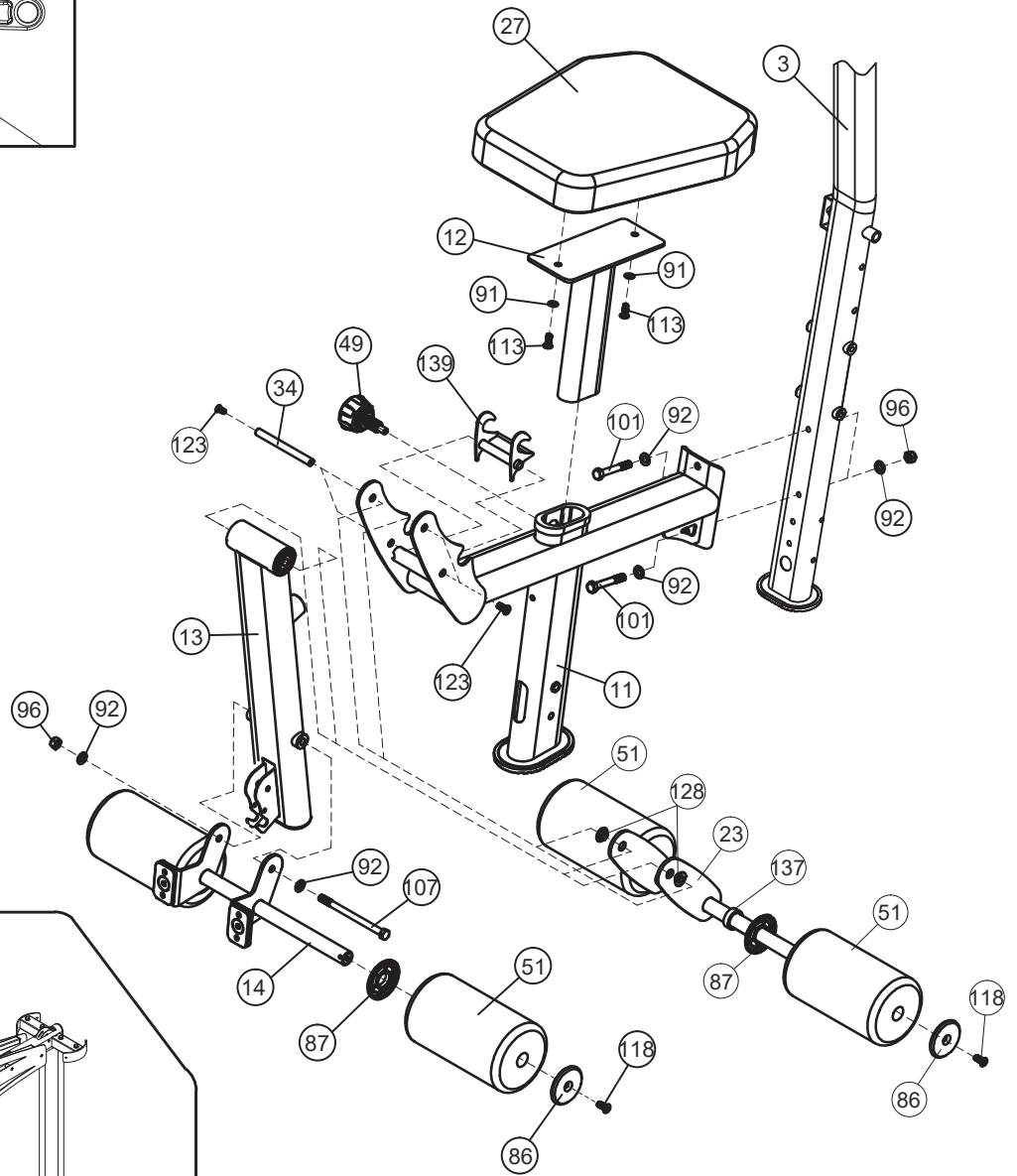
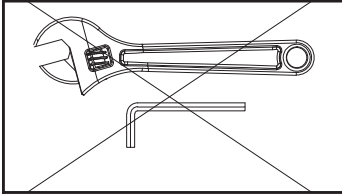

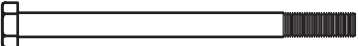
106  ×4 M10×140

99  ×2 M10×45

104  ×2 M10×115

117  ×2 M10×95

100  ×1 M10×65

92  ×20 Φ10

96  ×11 M10

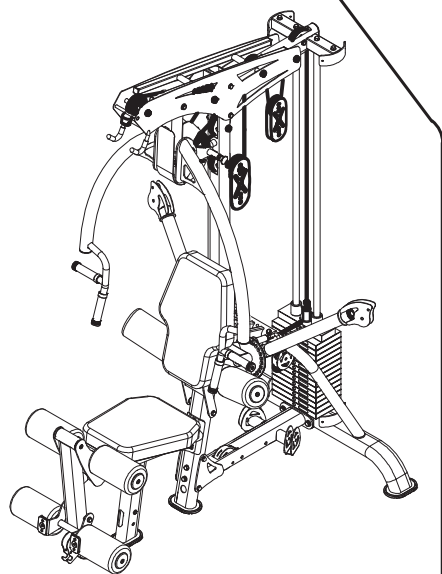
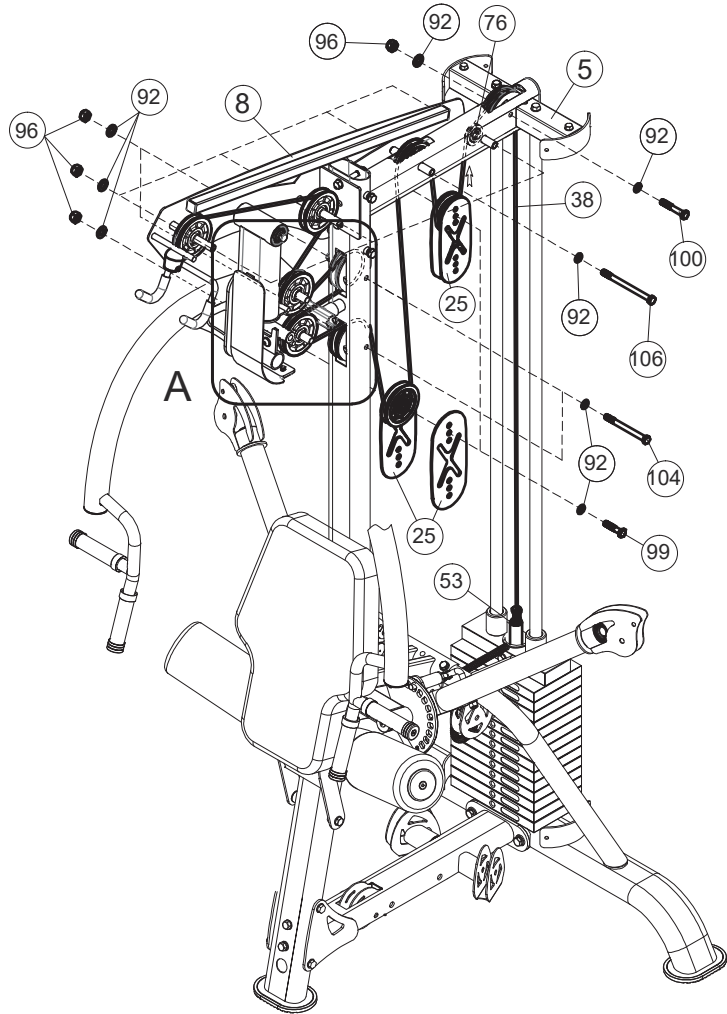
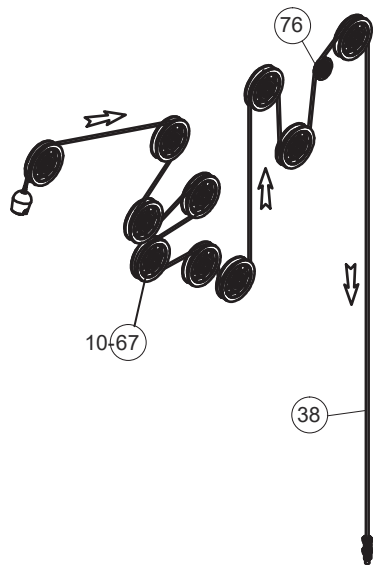
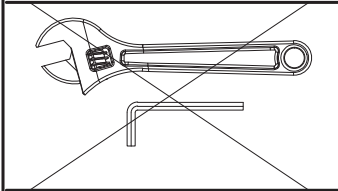

A

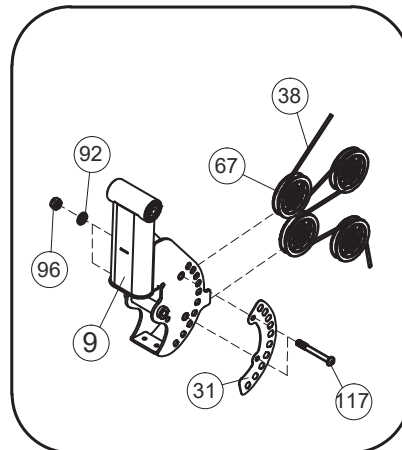

99  ×7 M10×45

91  | ×4 Φ8

95  ×2 M8

114  ×2 M8×45

92  | ×12 Φ10

96  ×5 M10

118  ×4 M8×20

35  × 2 Φ10×30×M8

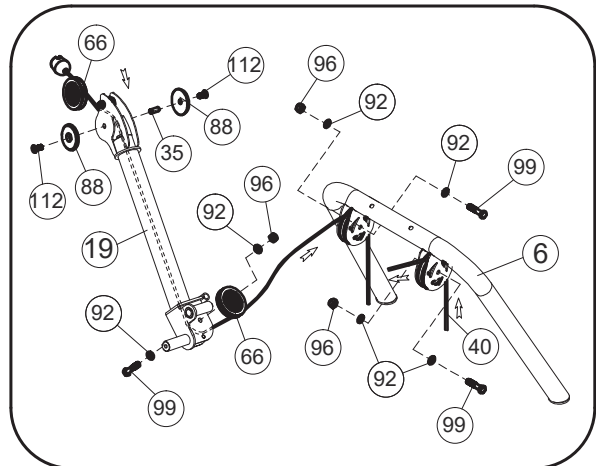
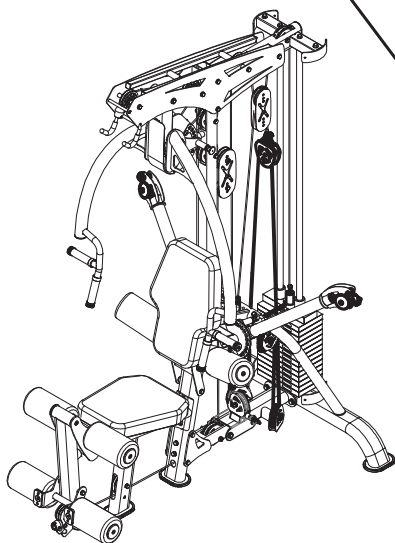
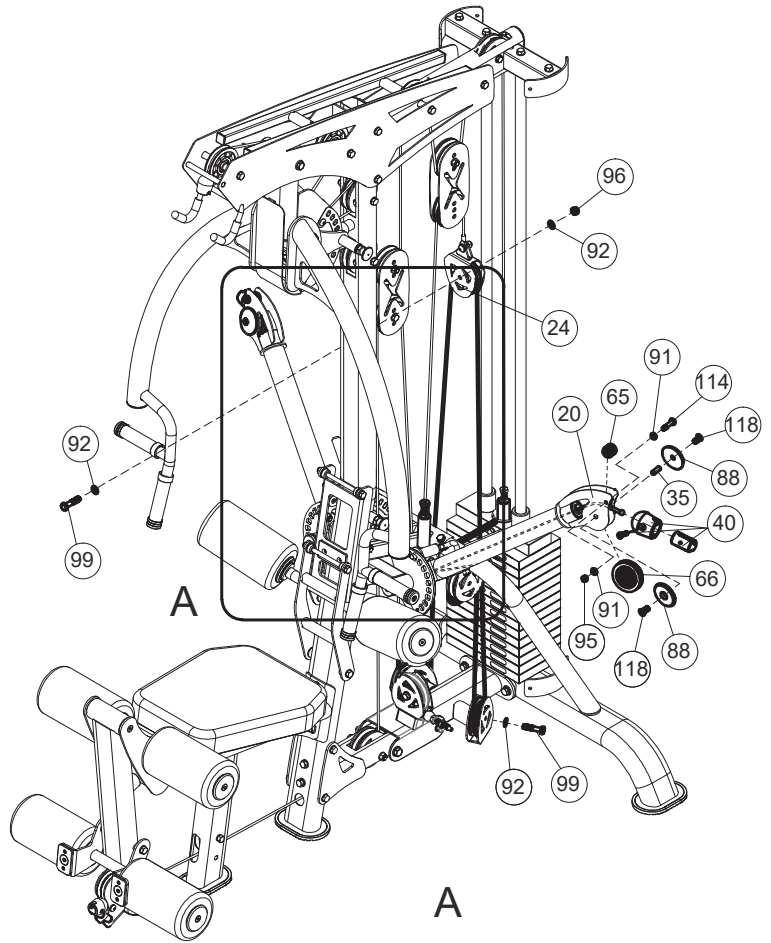
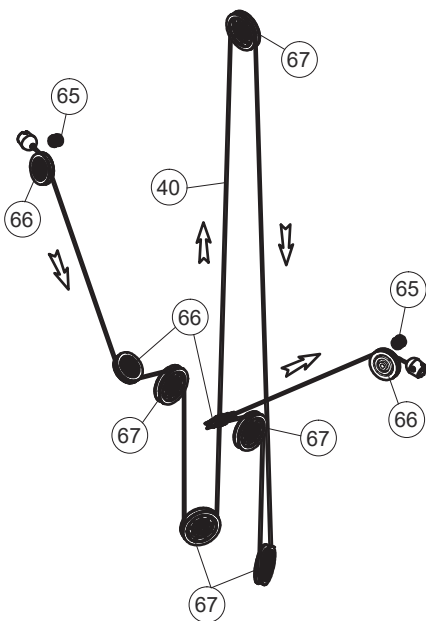
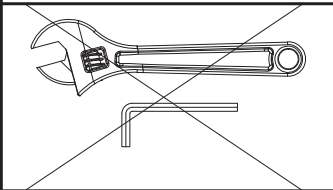

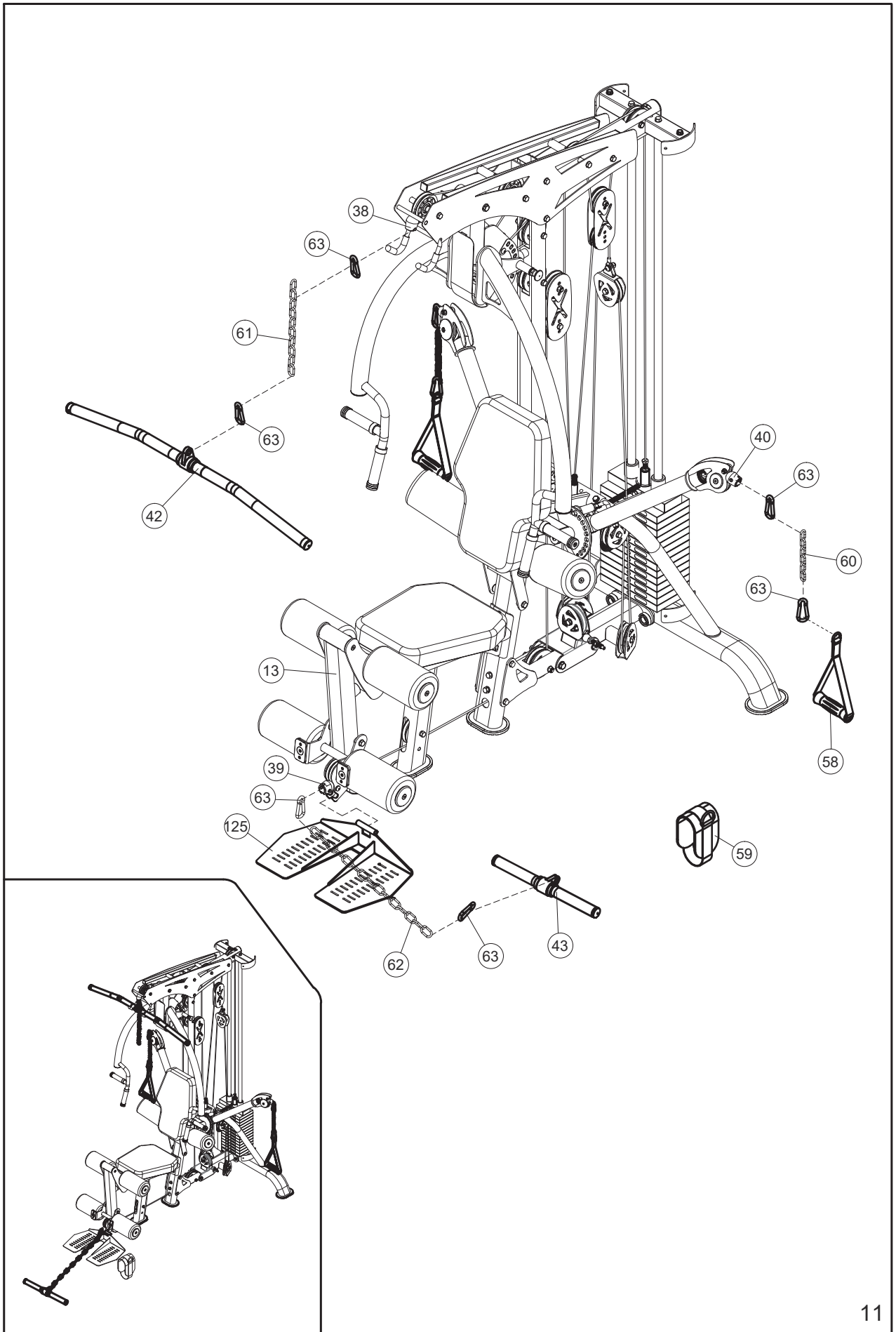

112  x8 M8x16

120  x8 M4x6

91  | x8 $\Phi 8$

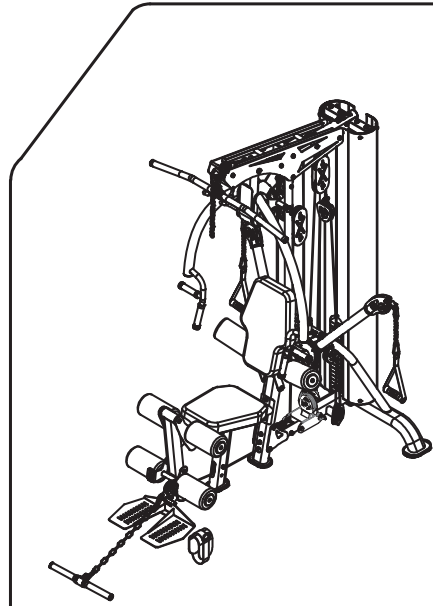
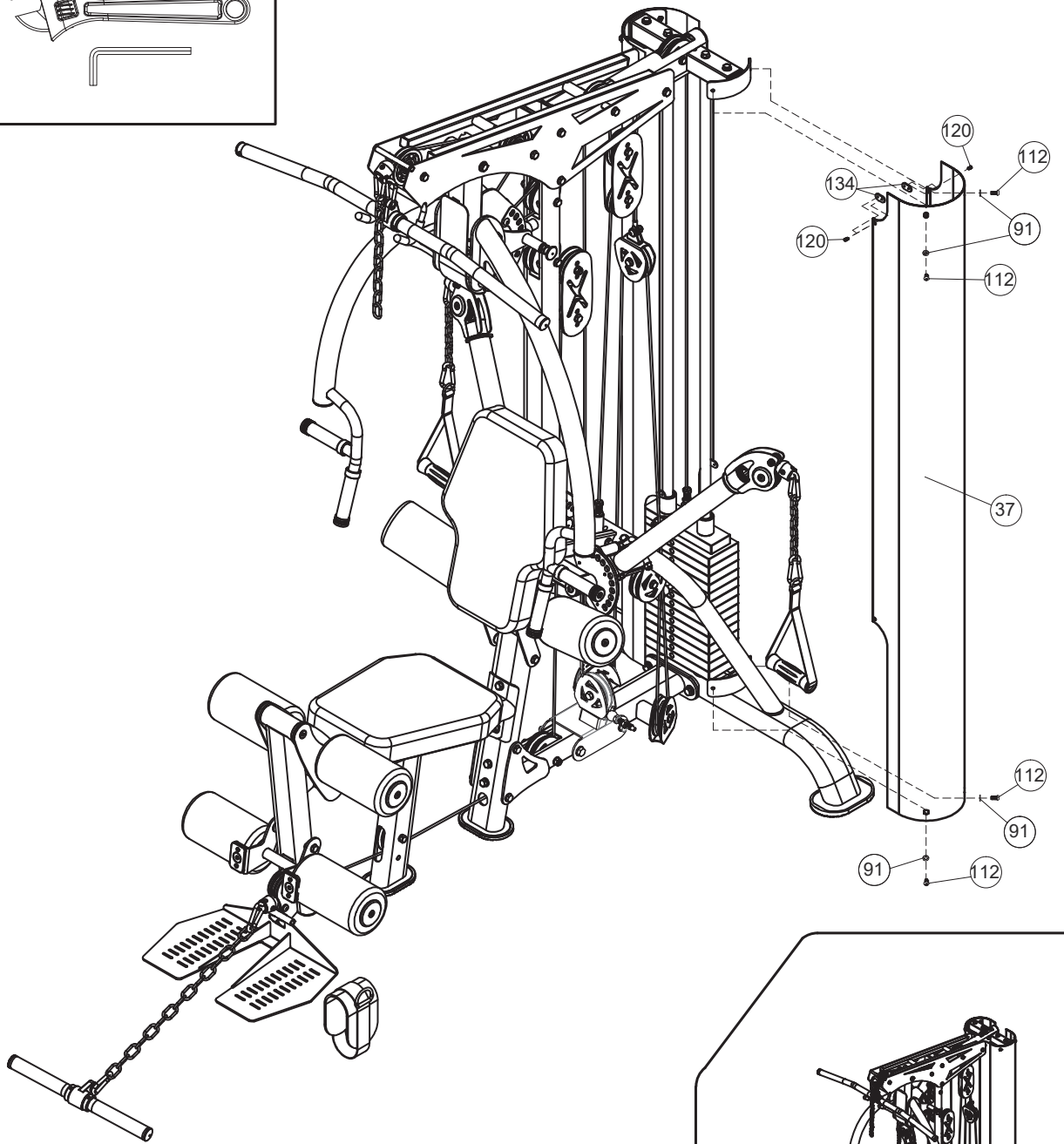
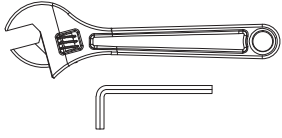

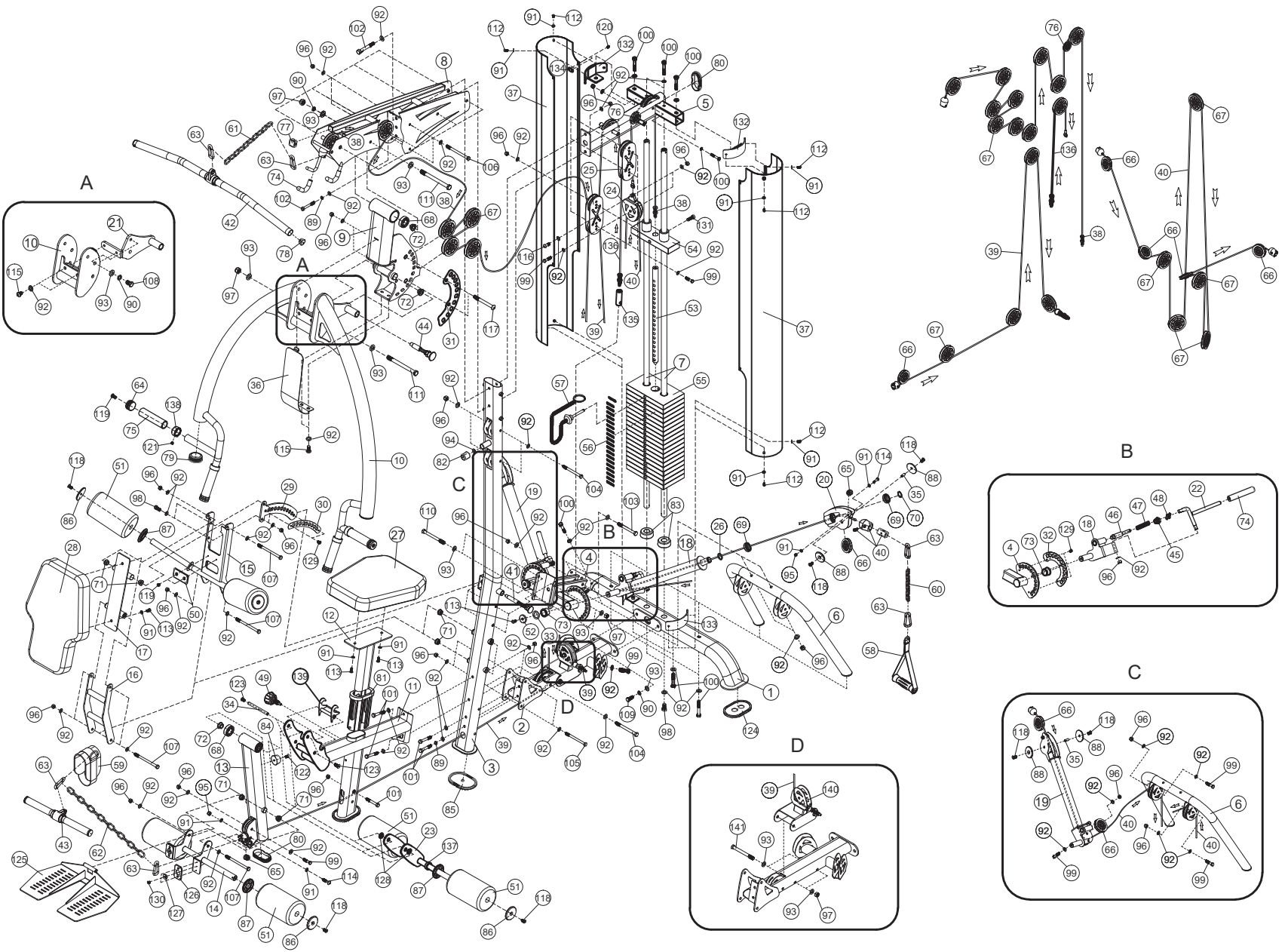

PARTS LIST

KEY NO.		SPEC	QTY
1	Base Frame Rear		1
2	Base Frame Front		1
3	Stand Vertical Frame Front		1
4	Butterfly Support		1
5	Upper Frame		1
6	Support Rear		1
7	Guide Rod Rear		2
8	Top Frame		1
9	Front Press Base		1
10	Front Press		1
11	Support Front		1
12	Seat Support		1
13	Leg Developer		1
14	Foam Frame		1
15	Top Connecting Frame		1
16	Base Connecting Frame		1
17	Backrest Support		1
18	Butterfly L		1
19	Butterfly R		1
20	Pulley Case		2
21	Front Press Base		1
22	Adjustable Shiver Bar		2
23	Foam Rod		1
24	Pulley Bracket		1
25	Adjustable Pulley Bracket	236×101×3	4
26	Bushing	φ30×φ25.5×3	2
27	Seat Pad	360×250×430×65	1
28	Backrest Board	366×520×65	1
29	draoB tserkcaB Adjustable	R290×R240×6	1
30	Decorative plate	R287×R243×1.5	1
31	Decorative plate	R125×R80×1.5	1
32	Decorative plate	R85×R45×1.5	2
33	D Washer	φ38×3	2
34	Silk shaft	Φ12×131×M8	2
35	Silk shaft	Φ10×30×M8	2
36	Front Lover	272×107×90×2	1
37	Weight Stack Cover	1793×R91.5×1	2
38	Upper Cable	L=4305	1
39	Connectable Cable	L=3580	1
40	Butterfly Cable	L=5600	1
41	Lock Knob		1
42	Lat Bar		1
43	Shiver Bar		1
44	Lock Knob		1

KEY NO.		SPEC	QTY
45	Cover Cap	21×M18×1.5×18	2
46	Pin Axle	Φ16×106	2
47	Spring	φ12.4×φ1.2×38.2	2
48	Chain joint	08A(12.7)	2
49	Lock Knob	M18×φ10	1
50	Rack Liner	90×45×5	1
51	Foam Roll	φ125×φ22×215	6
52	Bar End	φ38×φ9×8	2
53	Selector Rod	Φ25×563 (19+1)	1
54	Top Weight Plate	230×65×72	1
55	Weight Plate	250×100×25.4 (10LB)	19
56	Weight Plate Sticker	10LB-200LB	1
57	Weight Selector Pin		1
58	Nylon Strap Iso-Handle	L=245mm	2
59	Ankle Strap		1
60	6-Joint Chain	6	2
61	10-Joint Chain	10	1
62	15-Joint Chain	15	1
63	Hook	φ8	8
64	Decorative cover	φ37.5×φ6.5×19	4
65	Wheel	φ27×24	3
66	Small Pulley with Bearing	φ72×φ10	5
67	Pulley	φ96	20
68	Bearing	6004	4
69	Bearing	61905	4
70	Hole circlip	25	2
71	Bushing	φ25×φ10.5×12	10
72	Bushing	φ25×φ20×φ12.2×10	6
73	Bushing	φ38×φ34×φ25×22	4
74	Handle	Φ20×114	4
75	Handle	Φ27.5×3×135	4
76	Small Pulley with Bearing	Φ50×Φ10	1
77	End Cap	□25	4
78	End Cap	φ32	4
79	End Cap	φ50	2
80	End Cap	PT50×100	2
81	Slide Guide	PT50×100/PT40×80×147	1
82	Rubber Stopper	φ30×φ25×30	1
83	Rubber Stopper	φ62×φ24.5×25	4
84	Rubber Stopper	φ45×40	1
85	Floor End Cap	PT145×95×9	4
86	Foam Baffle	φ68×5.7	6
87	Foam Inner Baffle	φ70×φ26×9.5	6
88	End Cover	φ50×5.7	4
89	Spring Washer	10/336HV	2

KEY NO.		SPEC	QTY
90	Spring Washer	12	4
91	Washer	8	18
92	Washer	10	98
93	Washer	12	15
94	Washer	Φ25×11×2	1
95	Nut	M8	3
96	Nut	M10	43
97	Nut	M12	6
98	HEX Bolt	M10×25	4
99	HEX Bolt	M10×45	13
100	HEX Bolt	M10×65	11
101	HEX Bolt	M10×70	5
102	HEX Bolt	M10×75	2
103	HEX Bolt	M10×90	1
104	HEX Bolt	M10×115	3
105	HEX Bolt	M10×125	2
106	HEX Bolt	M10×140	6
107	HEX Bolt	M10×145	5
108	HEX Bolt	M12×20	1
109	HEX Bolt	M12×30	2
110	HEX Bolt	M12×130	2
111	HEX Bolt	M12×145	2
112	Allen Bolt	M8×16	8
113	Allen Bolt	M8×25	6
114	Allen Bolt	M8×45	3
115	Allen Bolt	M10×16	4
116	Allen Bolt	M10×30	1
117	Allen Bolt	M10×95	2
118	Hexagon socket countersunk head screws	M8×20	10
119	Hexagon socket countersunk head screws	M6×10	6
120	Philips Screw	M4×6	8
121	Set screw	M6×6	4
122	Philips Screw	M6×16	1
123	Allen Bolt	φ 20×M8×12	4
124	Floor End Cap	PT170×107×15	2
125	Foot Plate		1
126	Rack Liner	70×45×5	2
127	Magnet	φ25×φ5×4	2
128	Bushing	φ25×φ16×φ12.2×5	2
129	Philips Screw	M5×12	8
130	Philips Screw	M4×10	6
131	Allen Bolt	M10×55 (全丝)	1
132	Upper Frame		2
133	Lower Frame		2
134	Plate	30×14×3×M4	4

KEY NO.		SPEC	QTY
135	Regulating Shaft	$\phi 25 \times 75$	1
136	Cable	L=1180	1
137	Spacer Sleeve	$\phi 30 \times 2 \times 8$	2
138	Retaining ring	$\phi 38 \times \phi 29.2 \times 14.5 \times M6$	4
139	Locking Frame		1
140	Pulley Bracket		1
141	HEX Bolt	M12× 135	2
	Allen wrench	6#	1
	Allen wrench	5#	2
	Allen wrench	4#	1
	Allen wrench	3#	1