

# FRENCH FITNESS

ASSEMBLY MANUAL

FF-FSR110

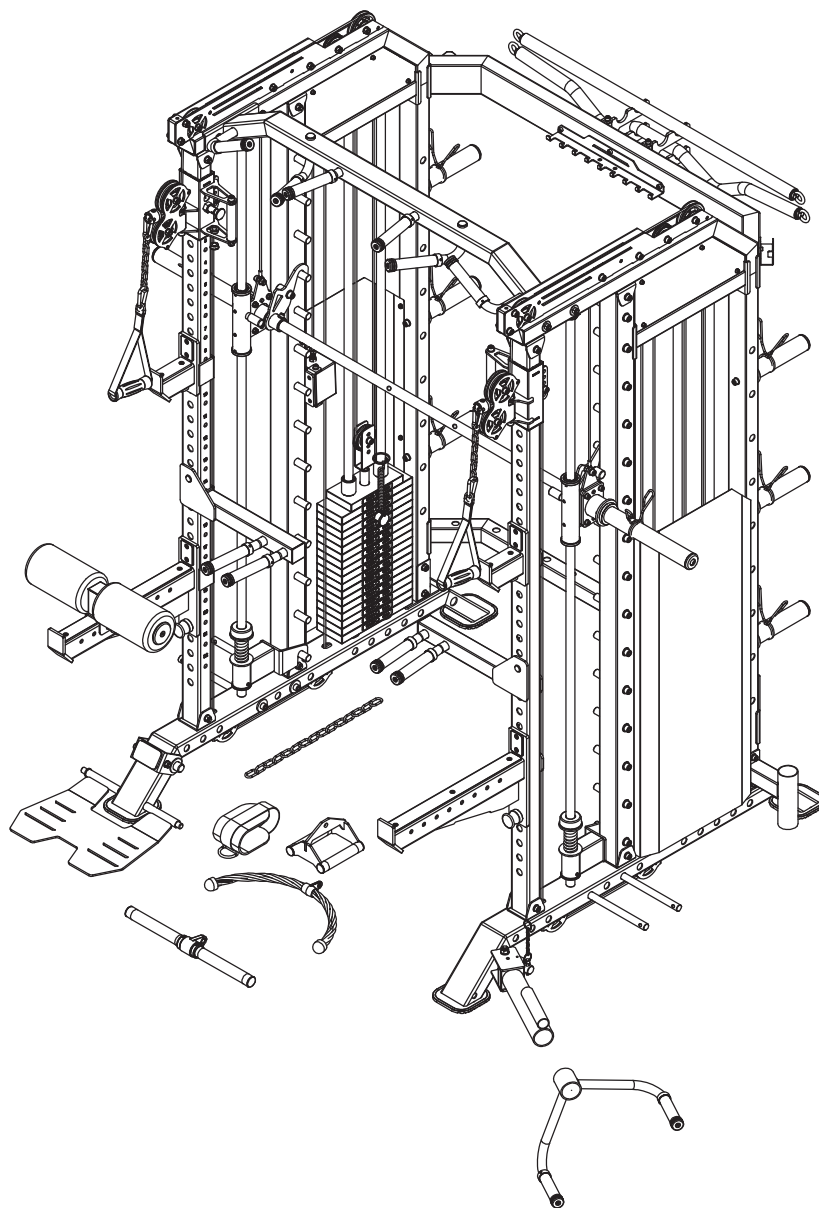

## CAUTION!

Read all precautions and instructions in this manual before using this equipment.

20251030-V1.0

## **IMPORTANT SAFETY NOTICE**

### **PRECAUTIONS**

This exercise machine is built for optimum safety. However, certain precautions apply whenever you operate a piece of exercise equipment. Be sure to read the entire manual before you assemble or operate your machine. In particular, note the following safety precautions:

1. **Keep children and pets away from the machine at all times. DO NOT leave children unattended in the same room with the machine.**
2. Only one person at a time should use the machine.
3. If the user experiences dizziness, nausea, chest pain, or any other abnormal symptoms, STOP the workout at once. CONSULT A PHYSICIAN IMMEDIATELY.
4. Position the machine on a clear, leveled surface. DO NOT use the machine near water or outdoors.
5. Keep hands away from all moving parts.
6. Always wear appropriate workout clothing when exercising. DO NOT wear robes or other clothing that could become caught in the machine. Running or aerobic shoes are also required when using the machine.
7. Use the machine only for its intended use as described in this manual. DO NOT use attachments not recommended by the manufacturer.
8. Do not place any sharp object around the machine.
9. Disabled person should not use the machine without a qualified person or physician in attendance.
10. Before using the machine to exercise, always do stretching exercises to properly warm up.
11. Never operate the machine if the machine is not functioning properly.

**WARNING: BEFORE BEGINNING ANY EXERCISE PROGRAM, CONSULT YOUR PHYSICIAN. THIS IS ESPECIALLY IMPORTANT FOR INDIVIDUALS OVER THE AGE OF 35 OR PERSONS WITH PRE-EXISTING HEALTH PROBLEMS. READ ALL INSTRUCTIONS BEFORE USING ANY FITNESS EQUIPMENT. WE ASSUMES NO RESPONSIBILITY FOR PERSONAL INJURY OR PROPERTY DAMAGE SUSTAINED BY OR THROUGH THE USE OF THIS PRODUCT.**

**SAVE THESE INSTRUCTIONS.**

**Assembled Dimension: 1990mm x 1790mm x2300mm**

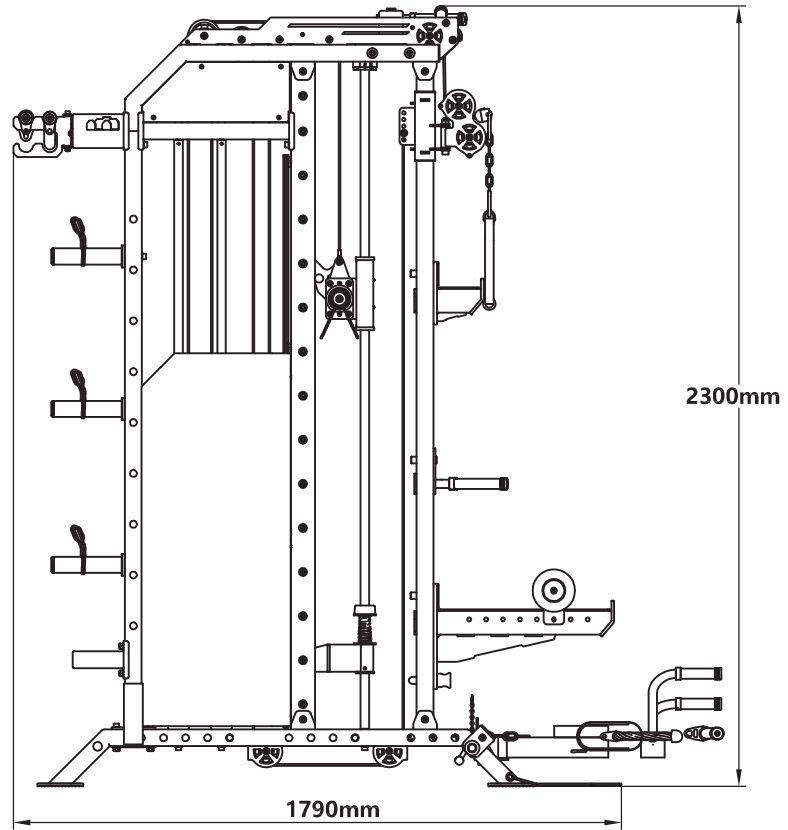
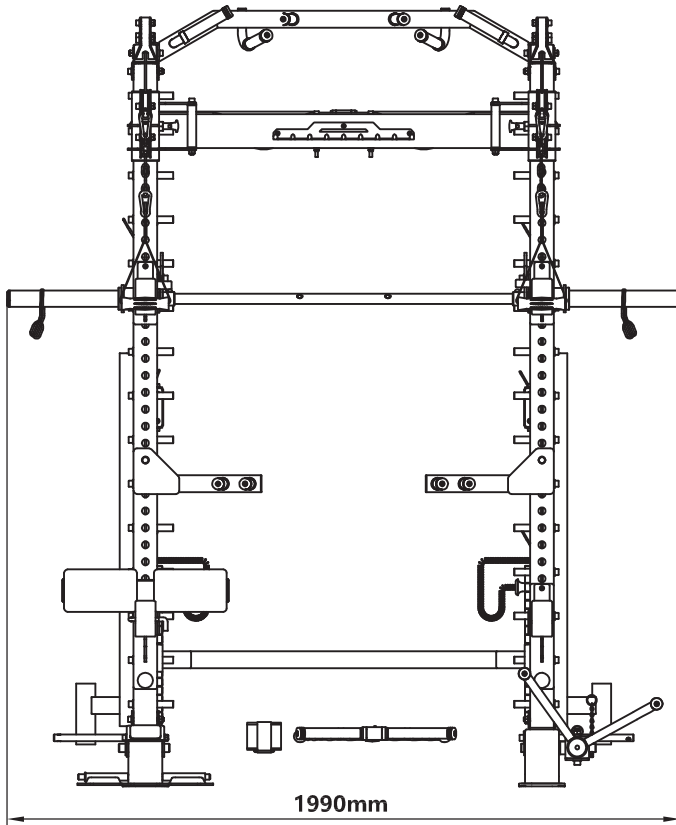

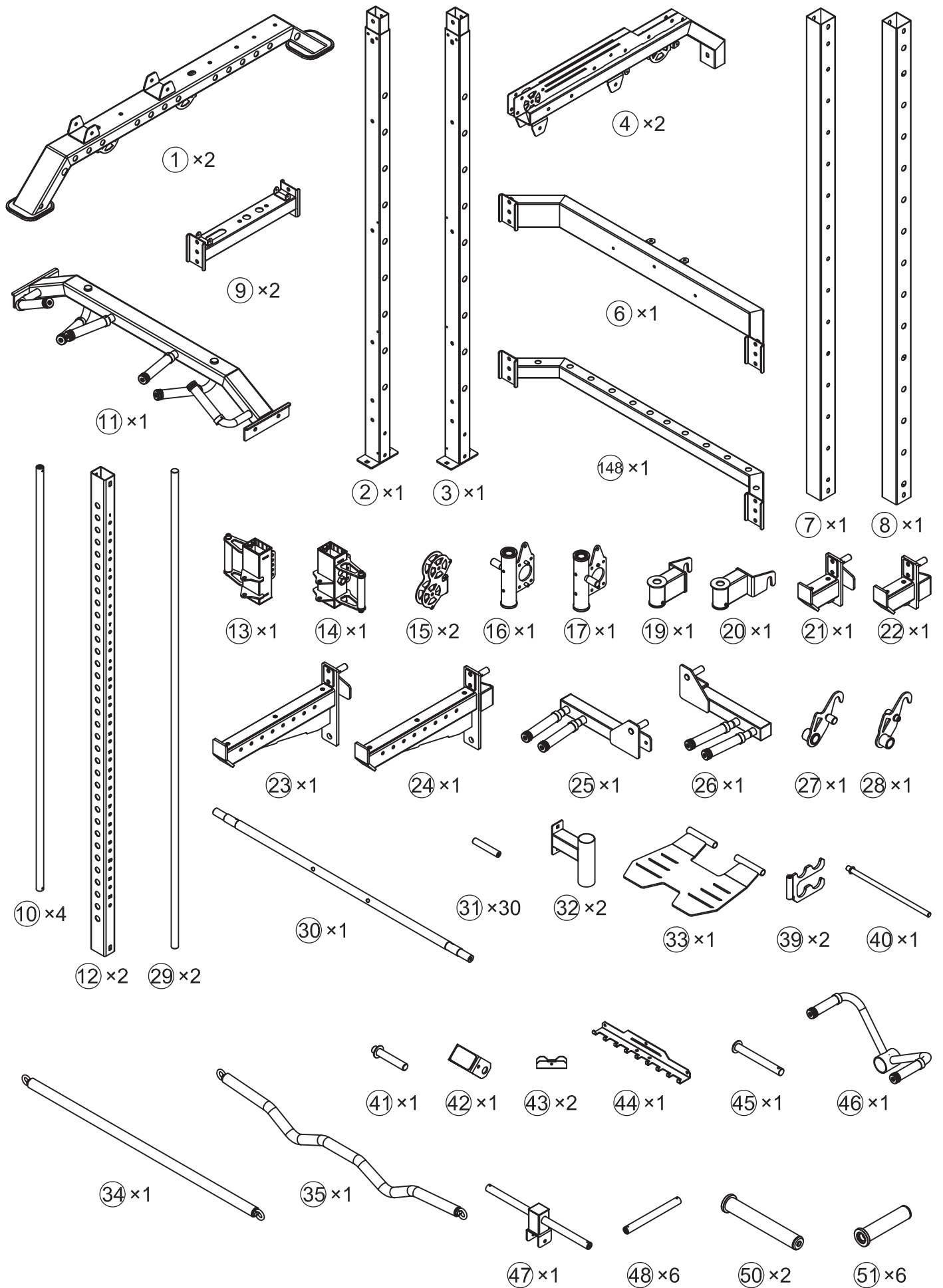

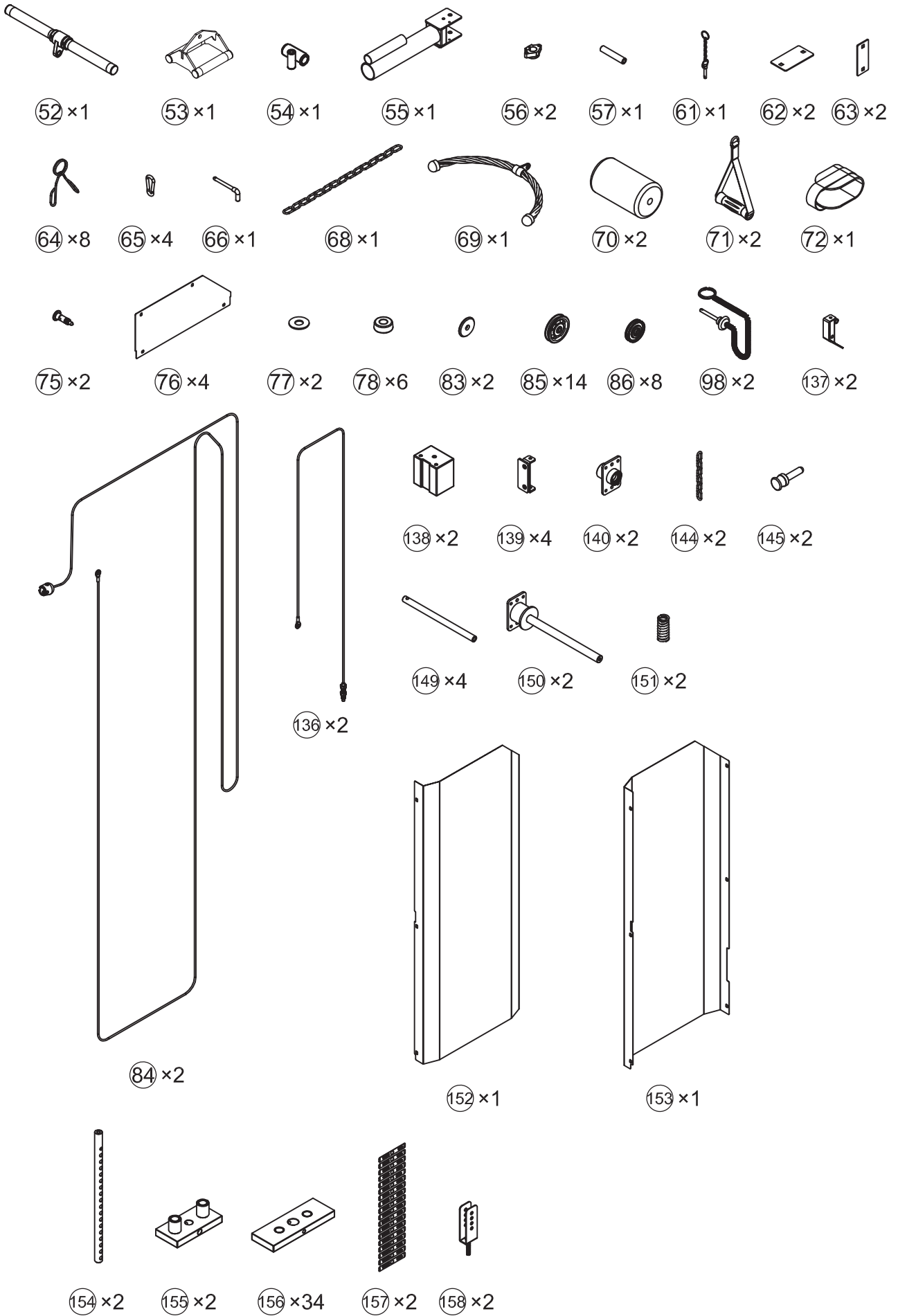

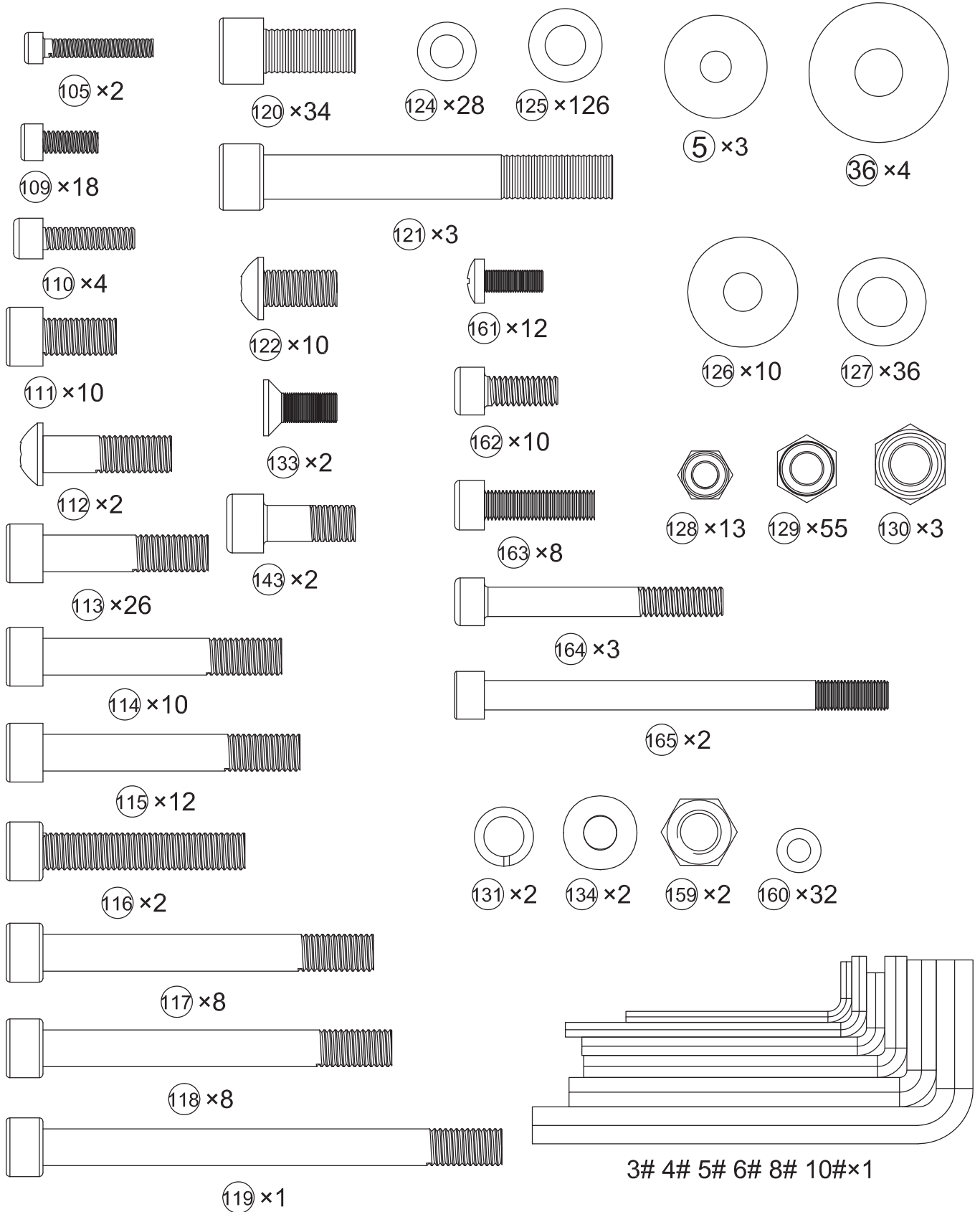

mm

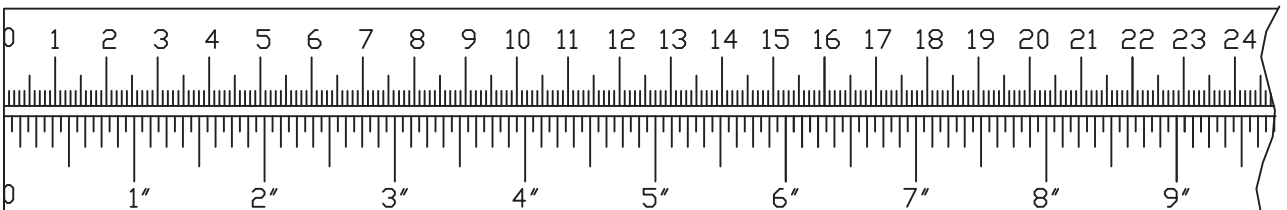

115		x8	M10x70	126		x4	Φ30xΦ10.5
125		x12	Φ10				
129		x8	M10				

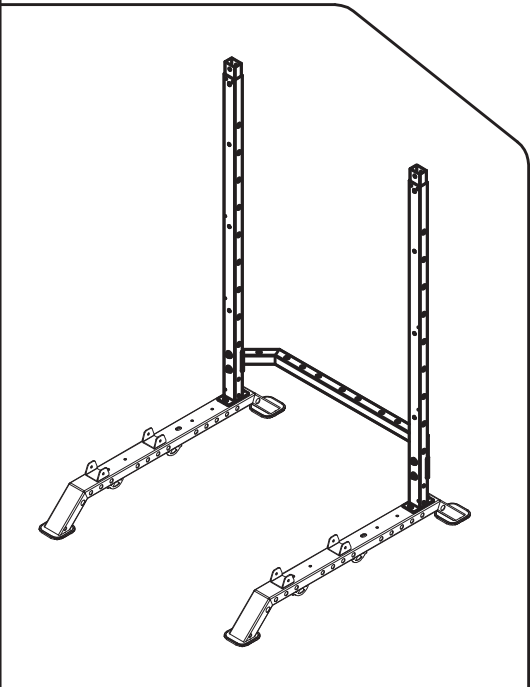
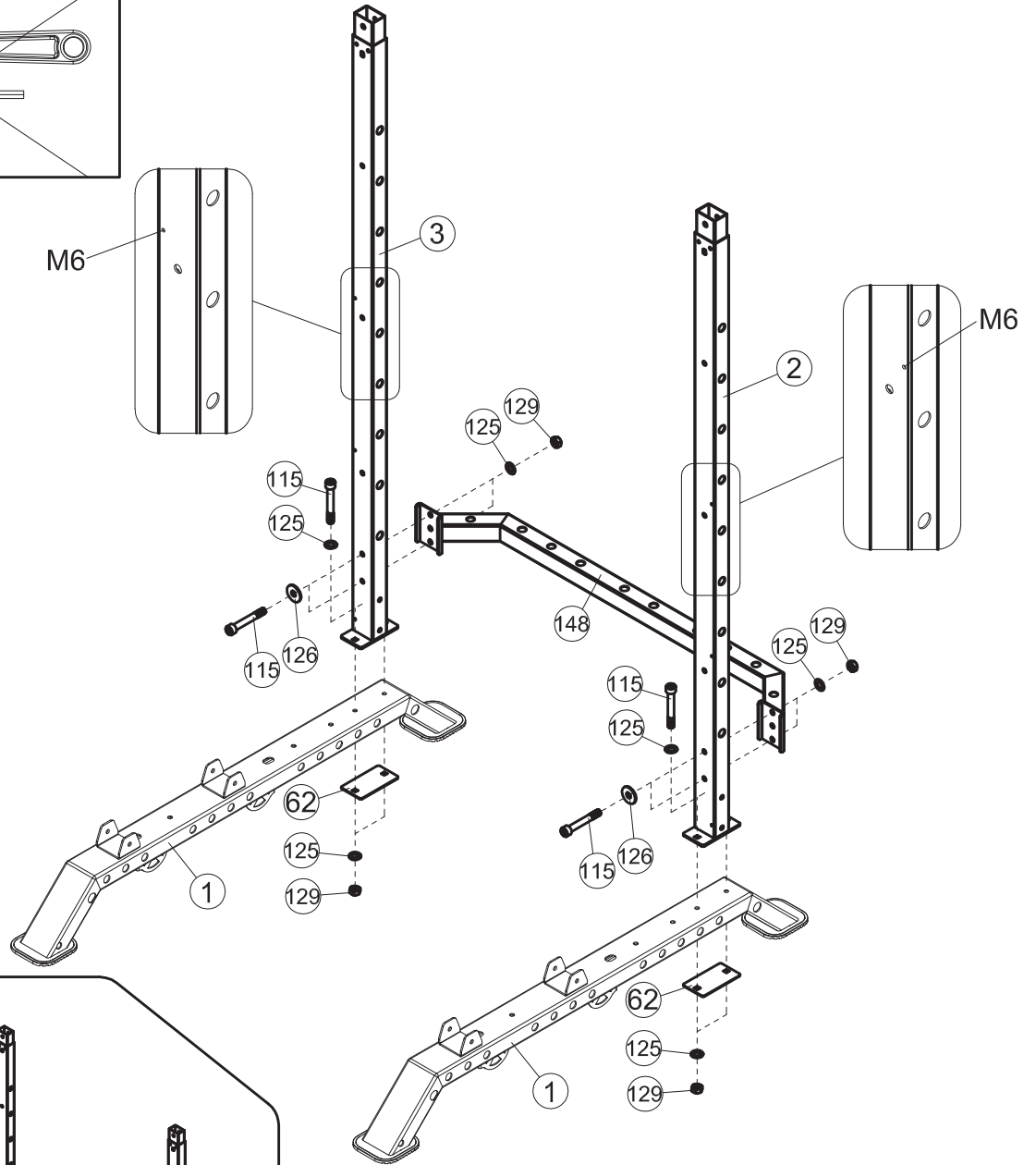
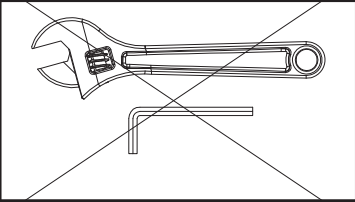

118

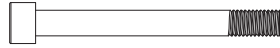

x4 M10x95

125



x8 Φ10

129



x4 M10

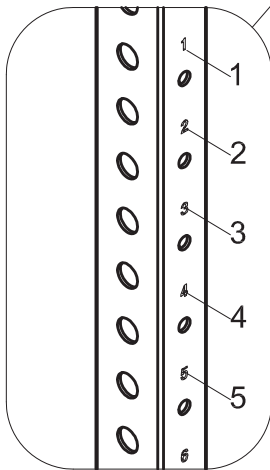
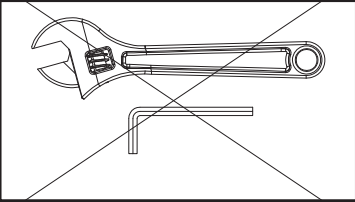

12

8

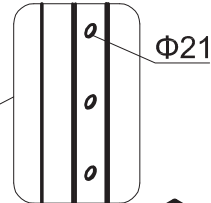

Φ21

12

7

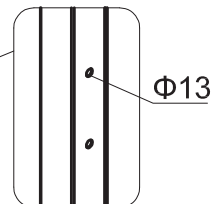

Φ13

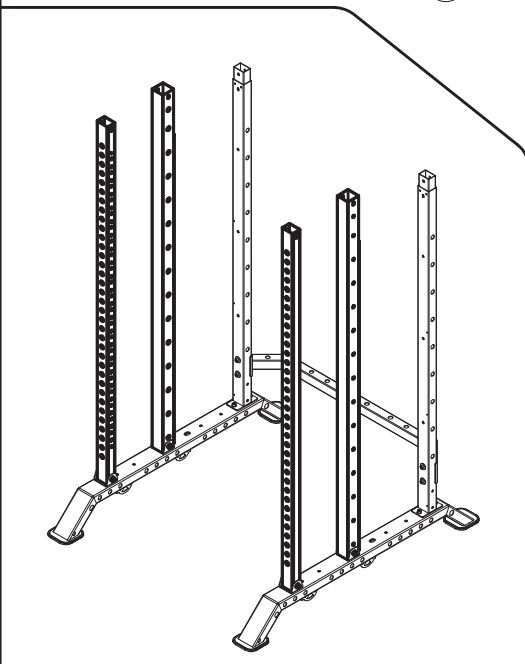
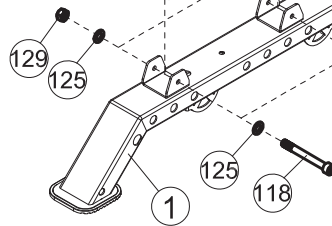
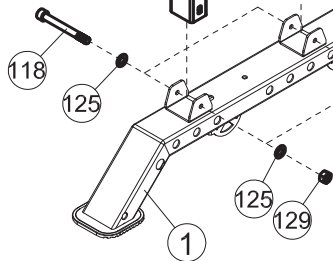

120

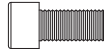

x30 M12x25

127



x30 Φ12

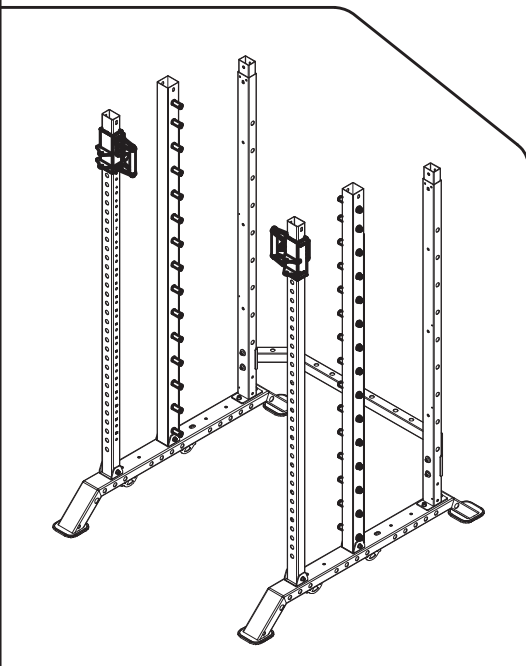
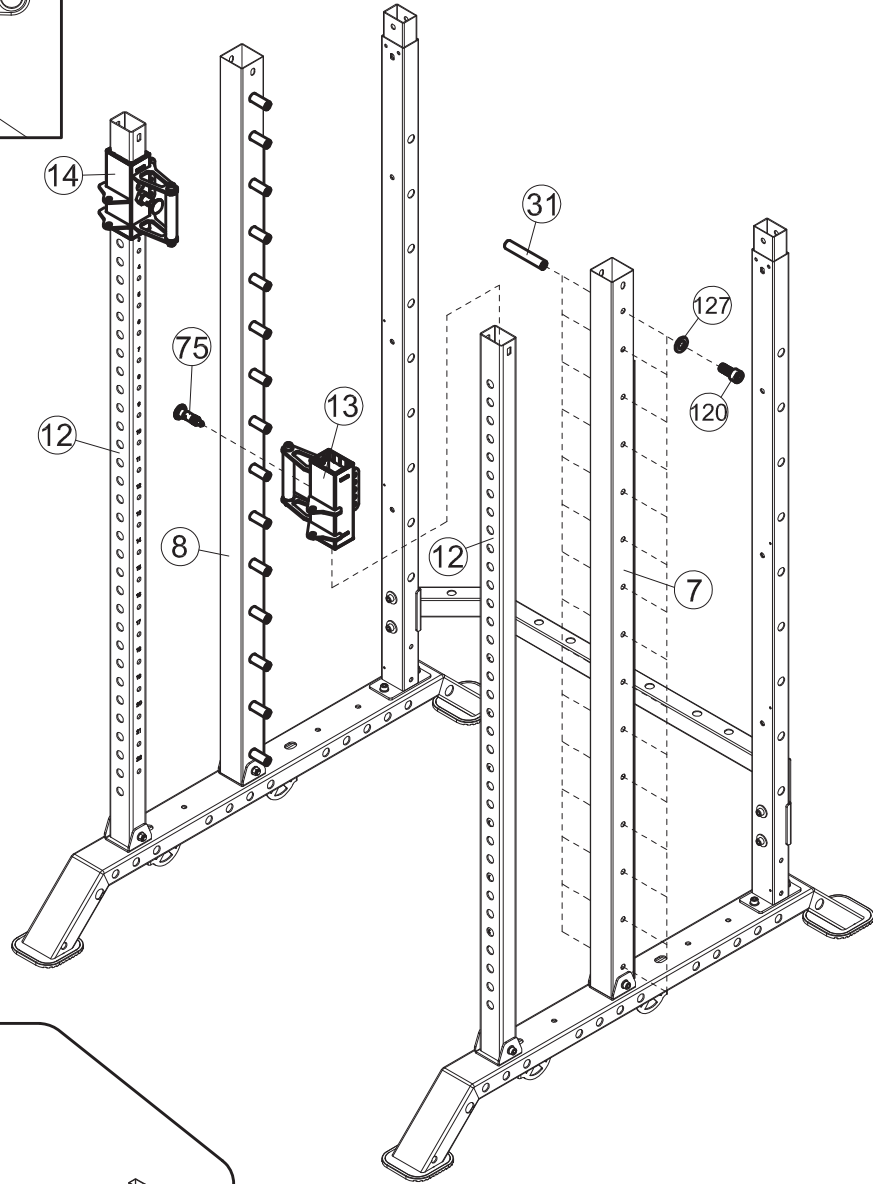
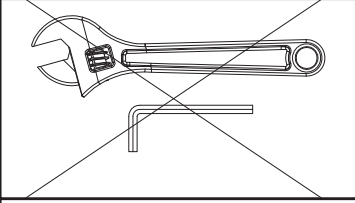

115

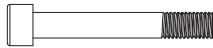

×2 M10×70

111



×4 M10×20

125



×6 Φ10

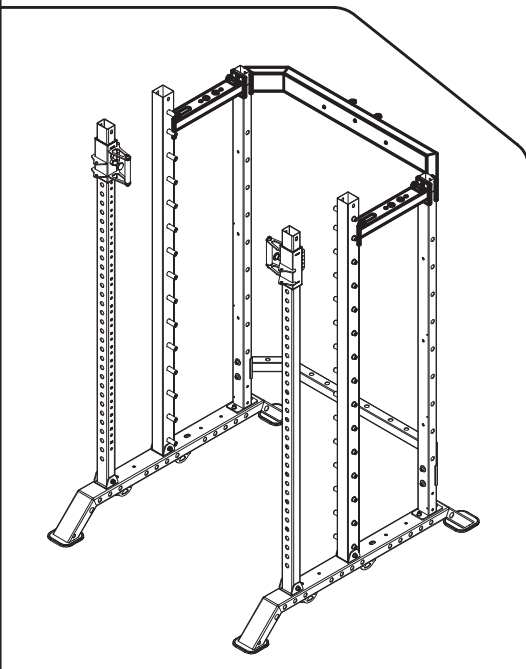
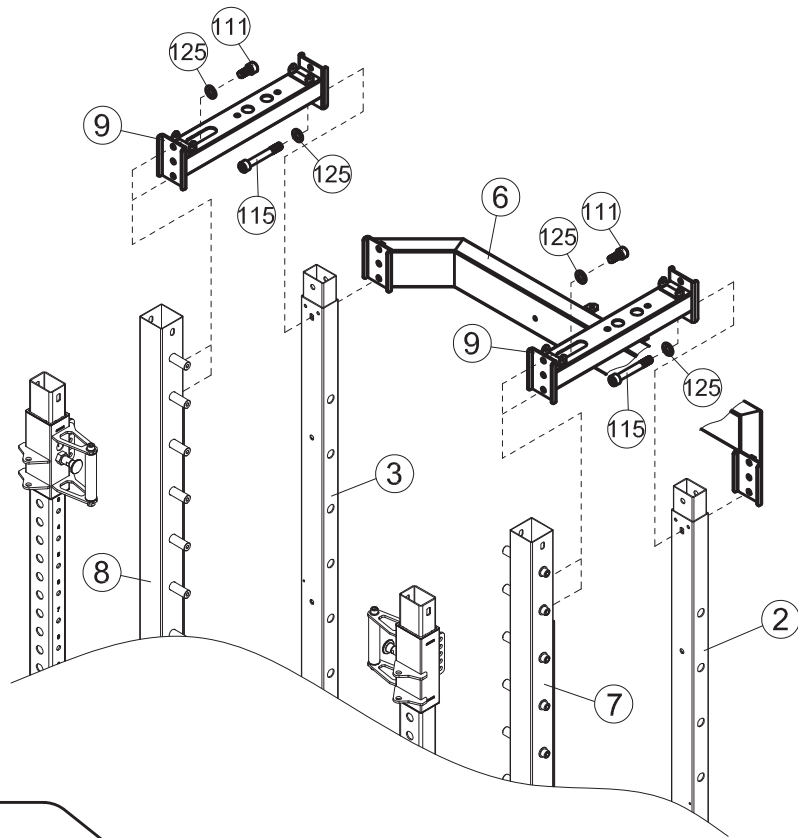
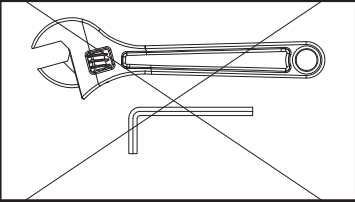

115

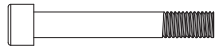

x2 M10x70

125



x10 Φ10

118

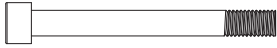







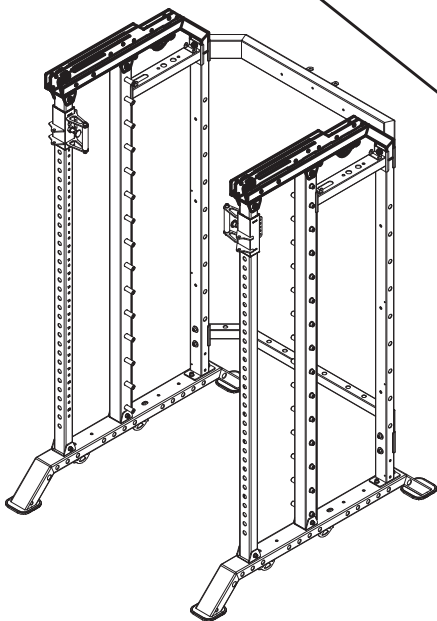
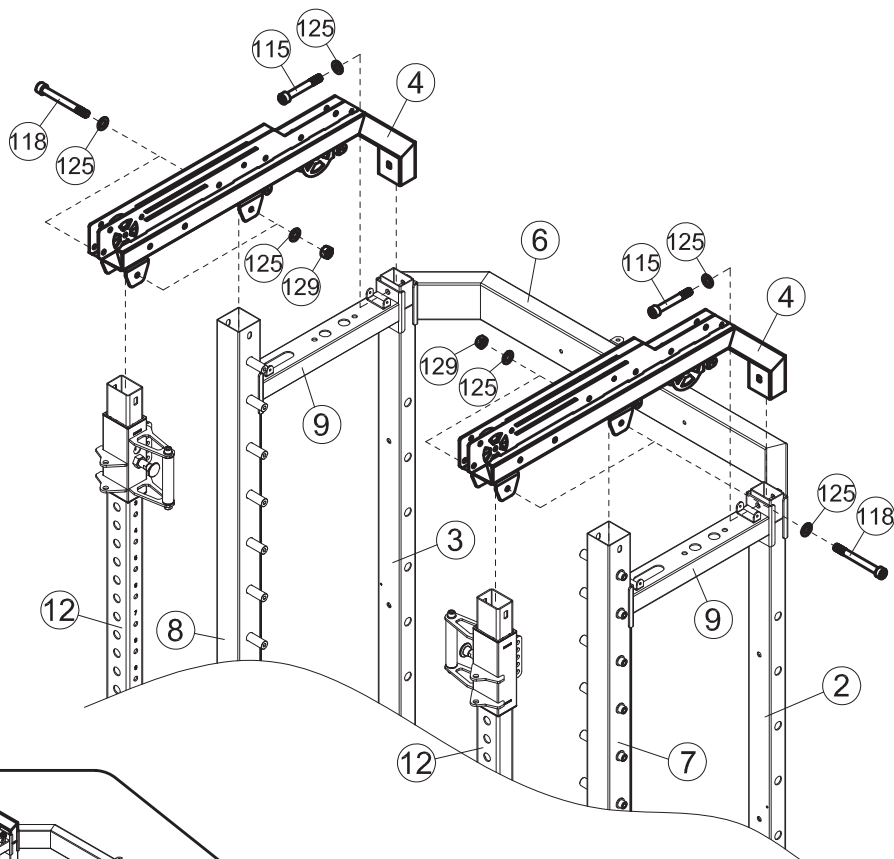
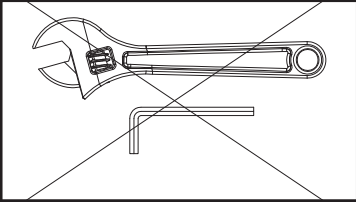

x4 M10x95

129







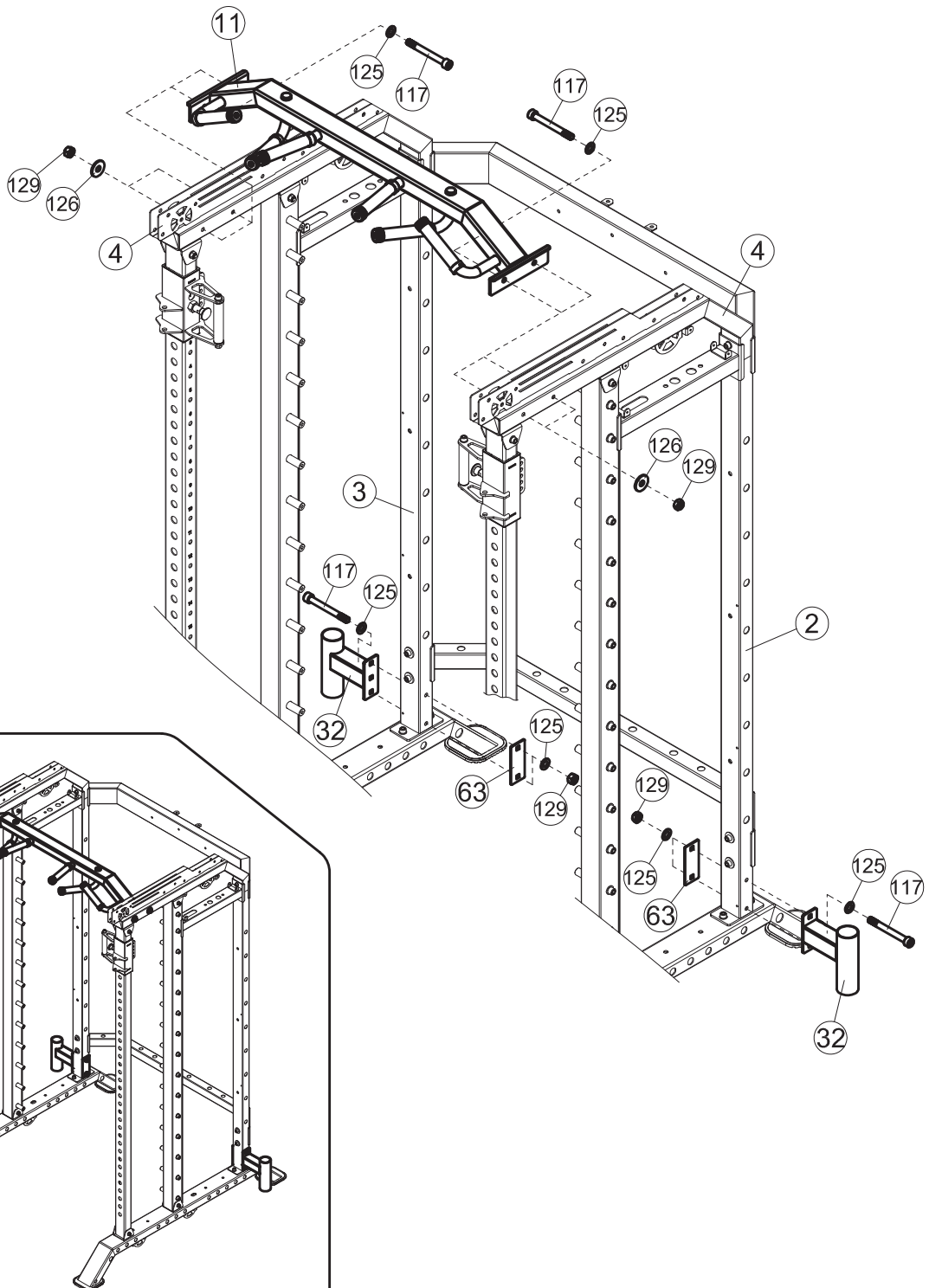
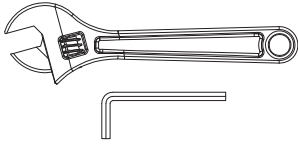

x4 M10

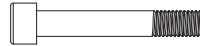







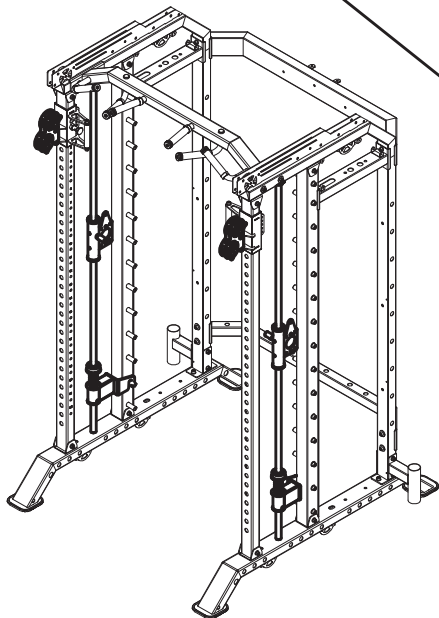
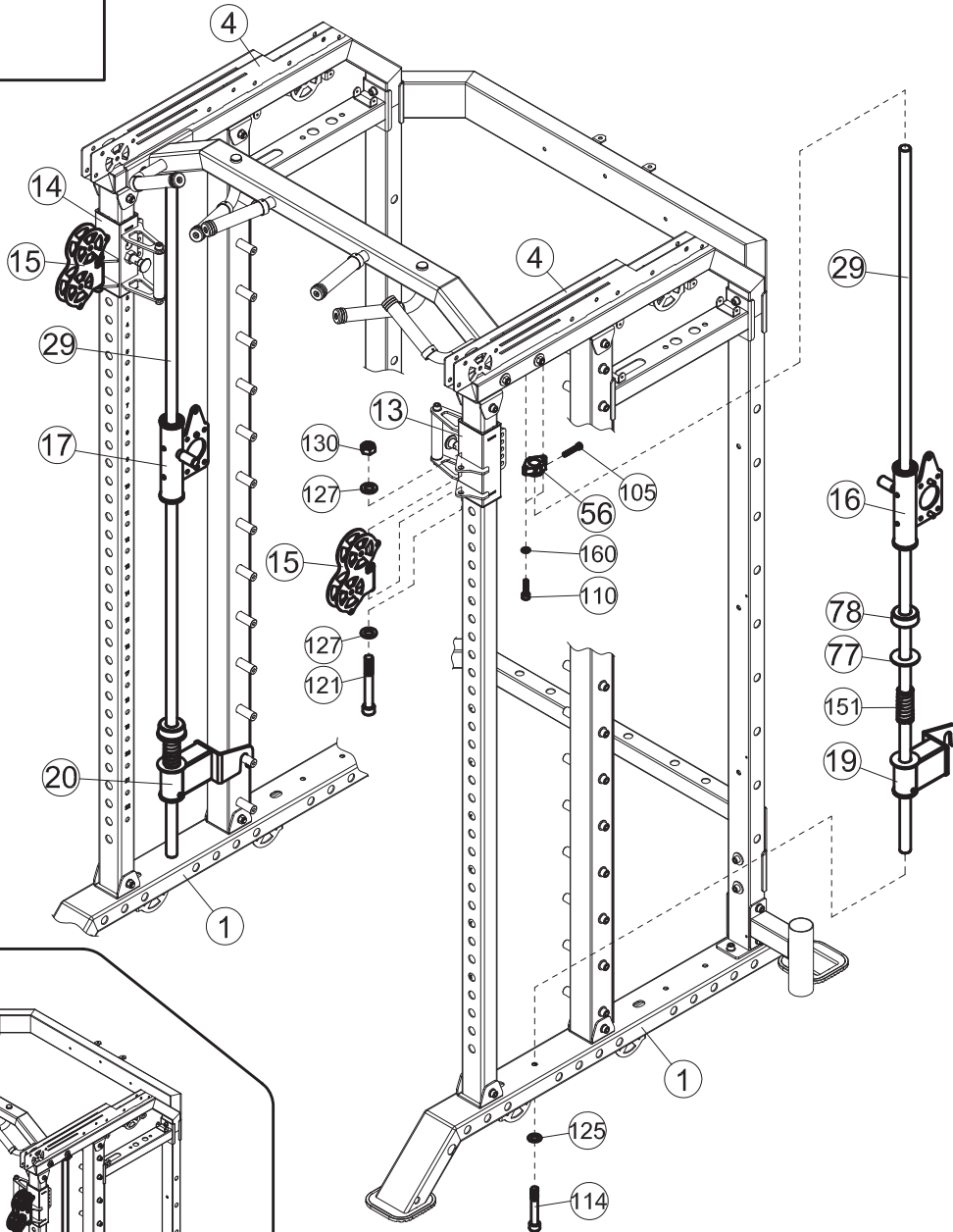
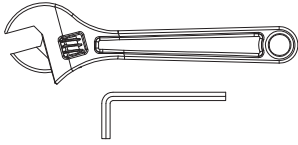

- 117  ×8 M10×90 126   ×4  $\Phi 30 \times \Phi 10.5$
- 125   ×12  $\Phi 10$
- 129   ×8 M10



121		x2	M12x95	114		x2	M10x65
127		x4	Φ12	125		x2	Φ10
130		x2	M12	110		x4	M6x30
105		x2	M5x25	160		x4	Φ6



- |     |   |     |        |     |  |    |           |
|-----|---|-----|--------|-----|--|----|-----------|
| 122 |  | x4  | M10x20 | 162 |  | x2 | M8x20     |
| 131 |  | x2  | Φ10    | 134 |  | x2 | R20xφ9    |
| 163 |  | x8  | M8x30  | 128 |  | x8 | M8        |
| 124 |  | x16 | Φ8     | 126 |  | x2 | Φ30xΦ10.5 |

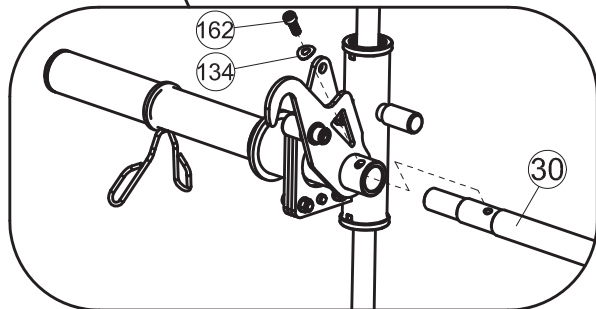
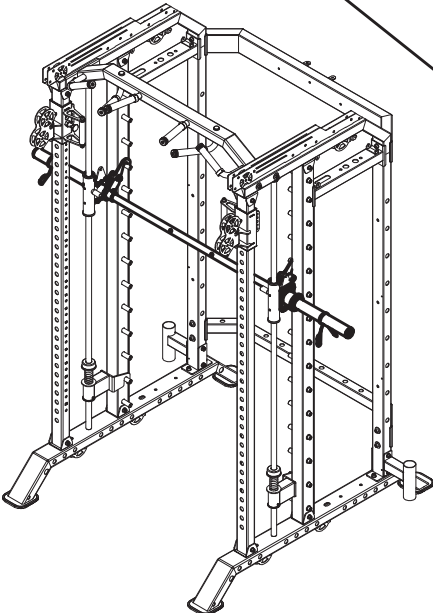
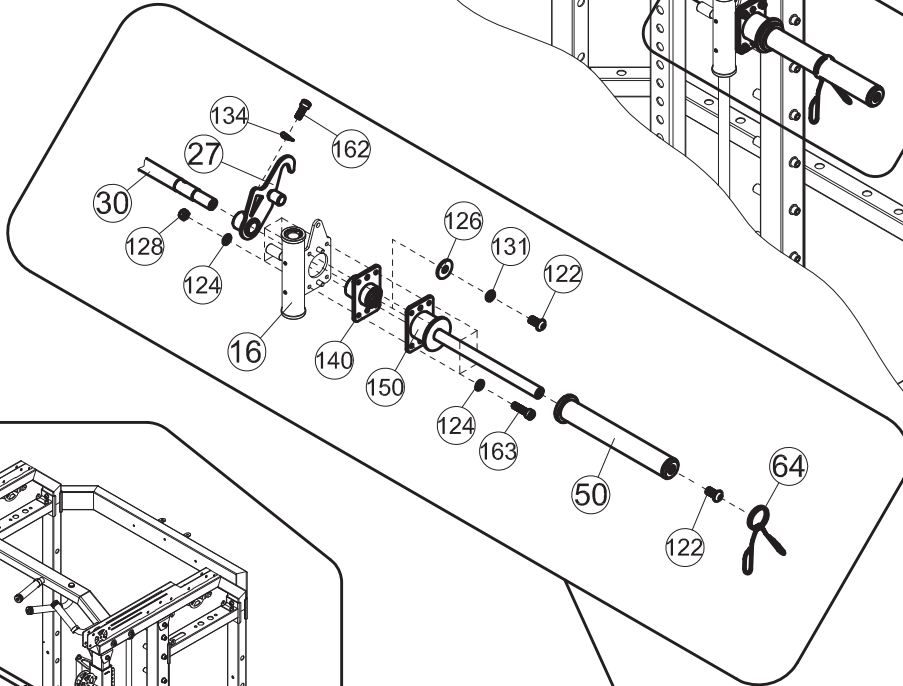
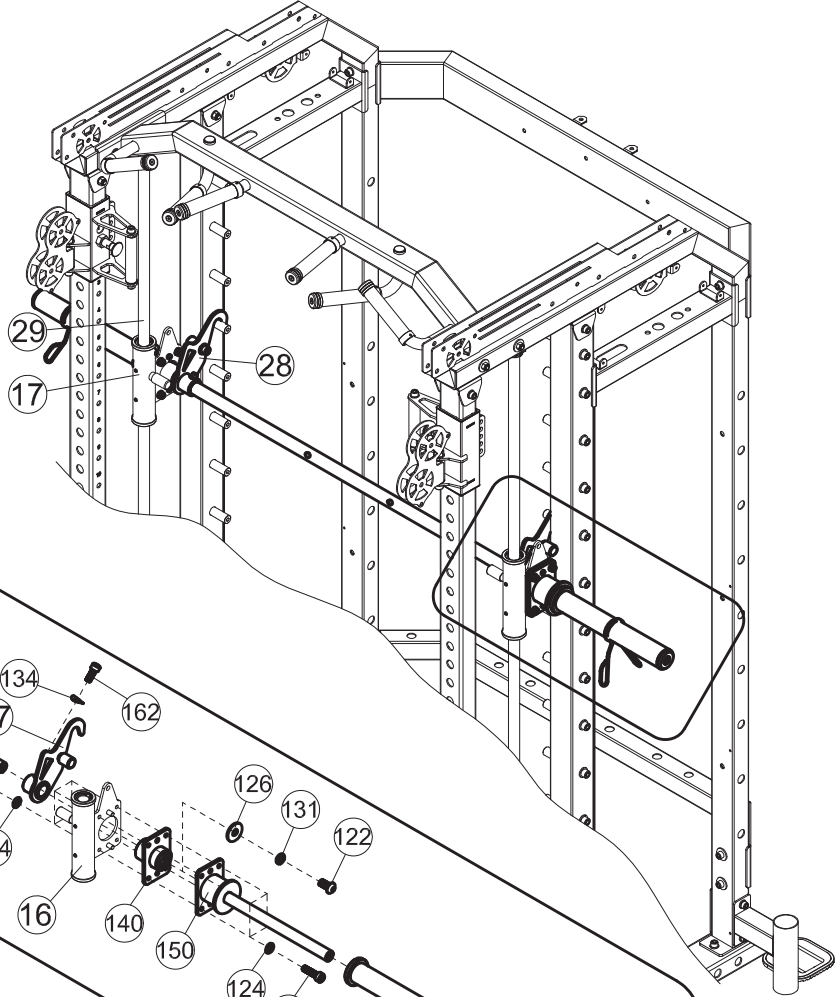
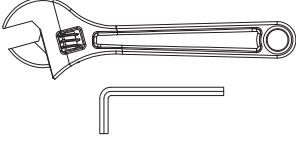

162



x8 M8x20

124



x8 Φ8

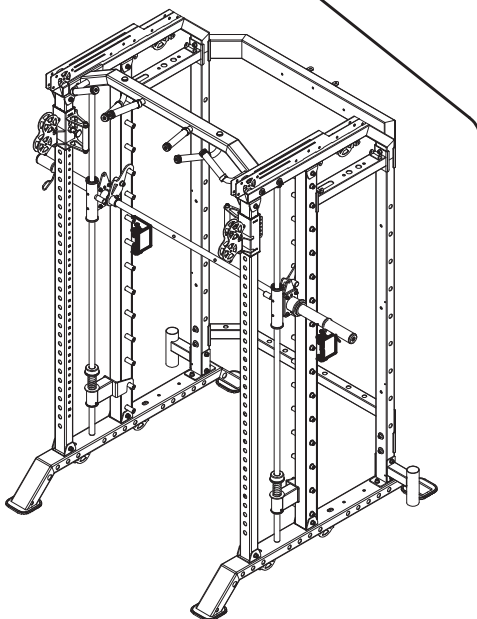
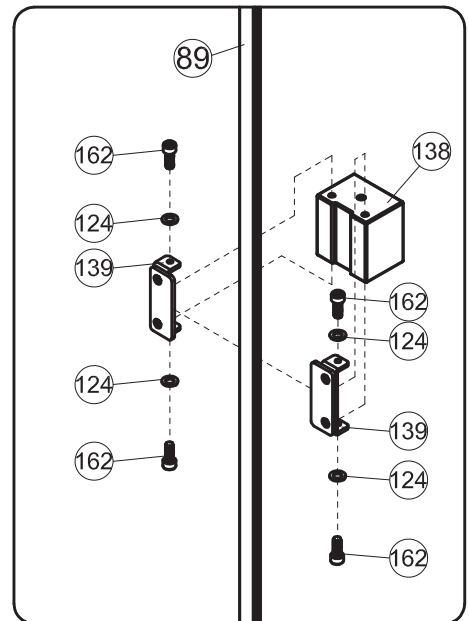
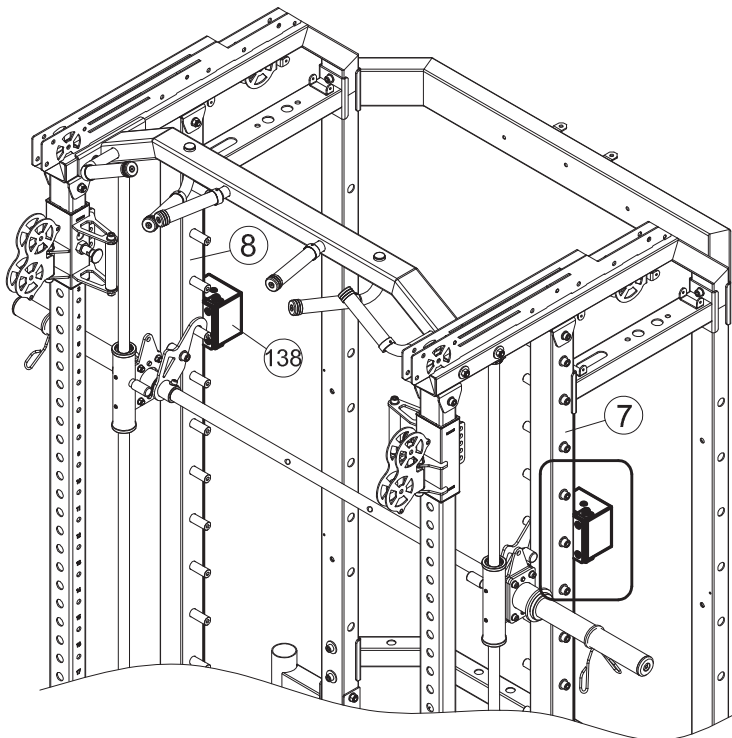
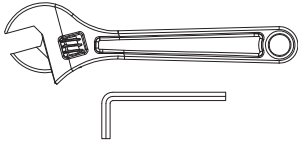

161

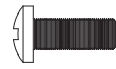

×12 M6×16

160



×12 Φ6

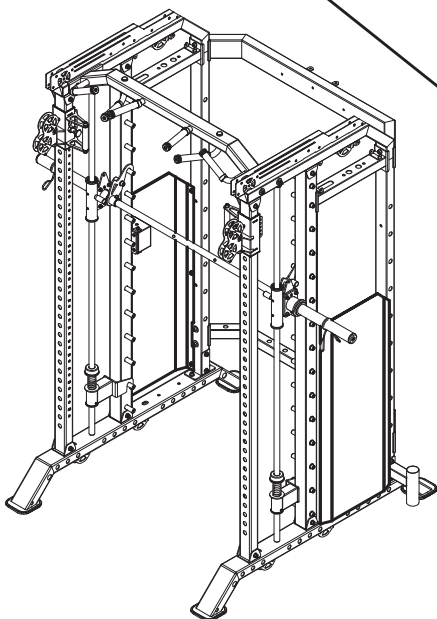
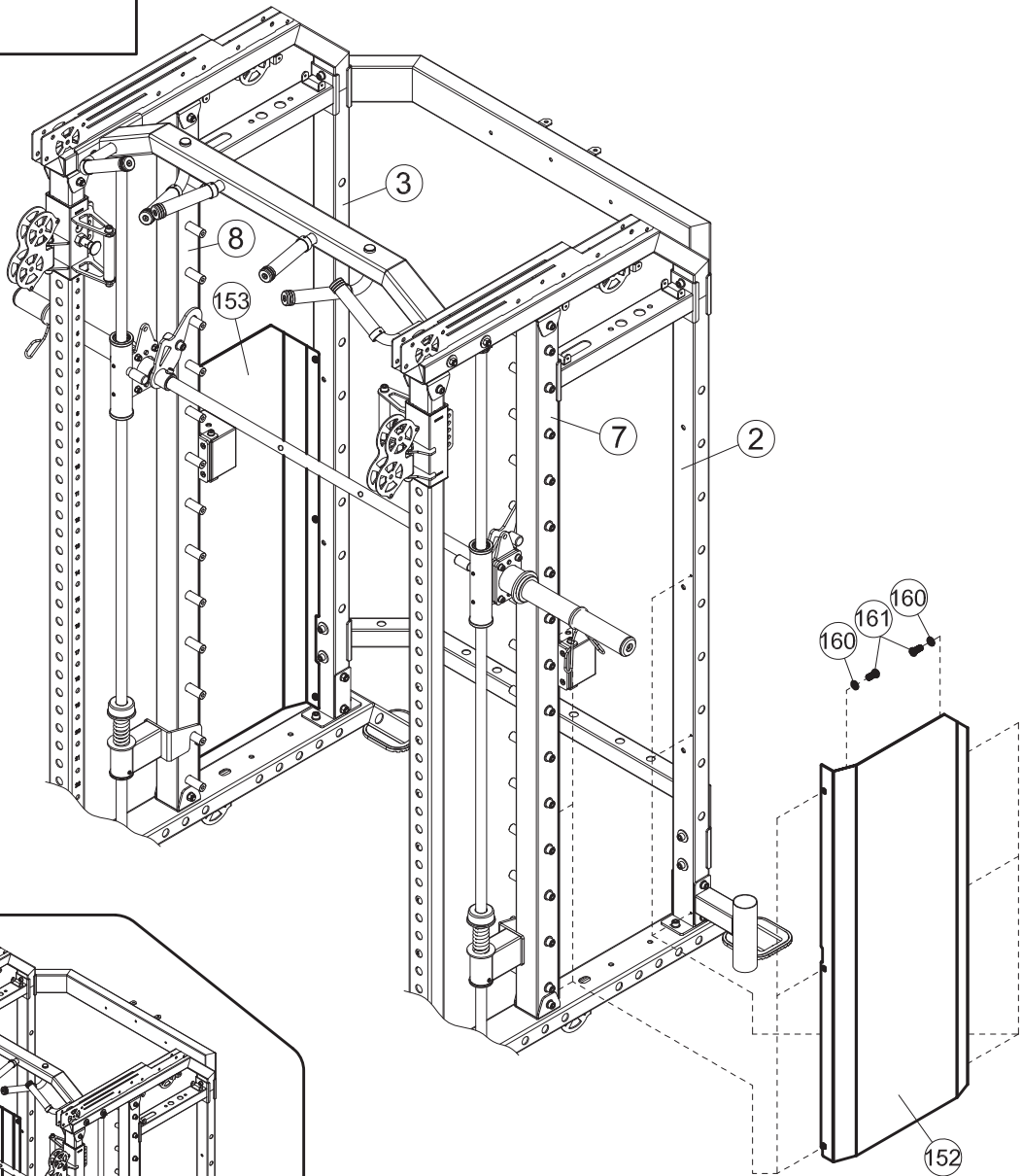
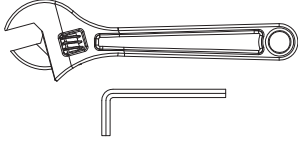

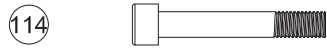

×8 M10×65

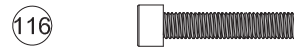

×2 M10×55



×8 Φ10





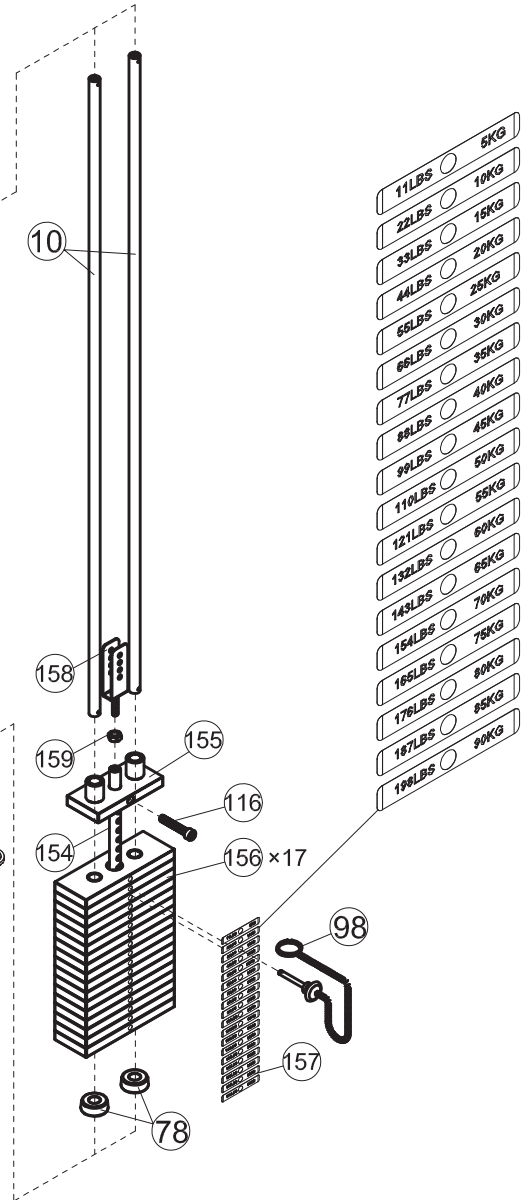
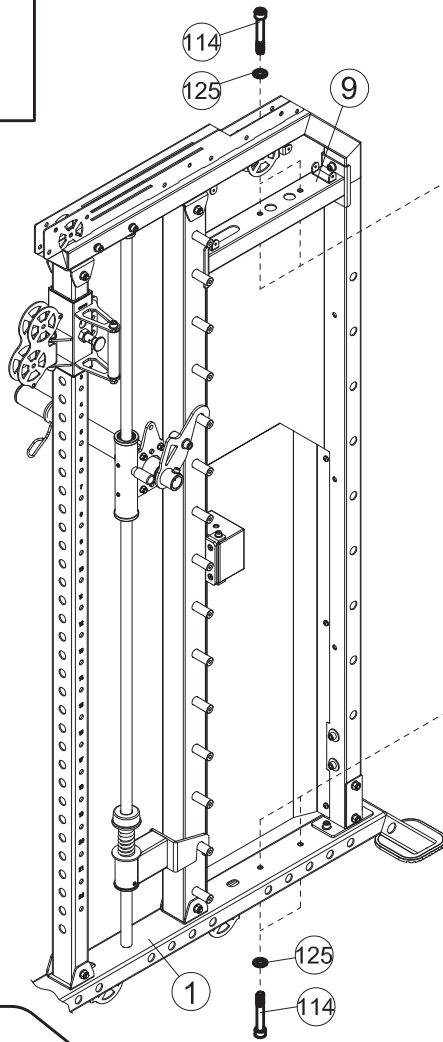
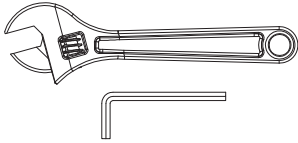

×2 M12

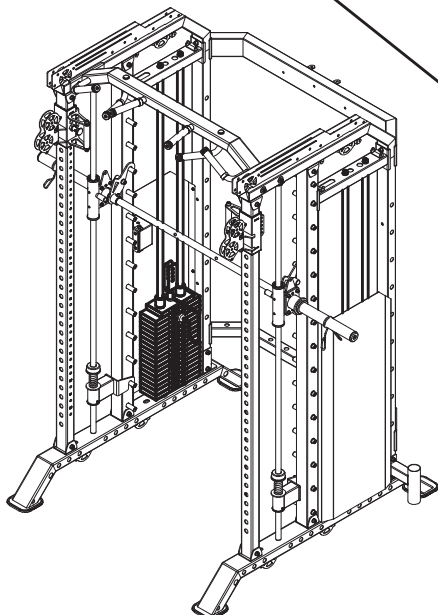



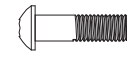

11LBS	○	5KG
22LBS	○	10KG
33LBS	○	15KG
44LBS	○	20KG
55LBS	○	25KG
66LBS	○	30KG
77LBS	○	35KG
88LBS	○	40KG
99LBS	○	45KG
110LBS	○	50KG
121LBS	○	55KG
132LBS	○	60KG
143LBS	○	65KG
154LBS	○	70KG
165LBS	○	75KG
176LBS	○	80KG
187LBS	○	85KG
198LBS	○	90KG

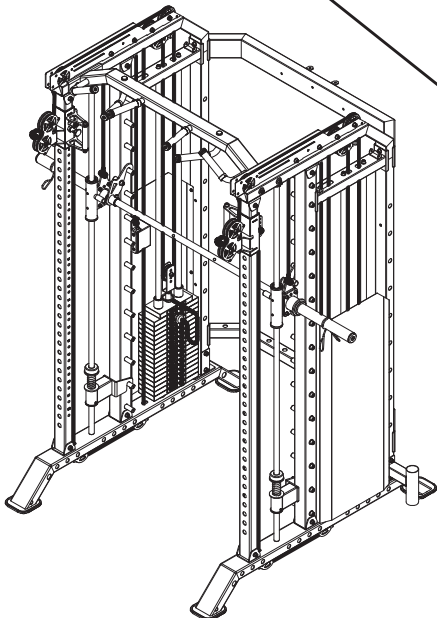
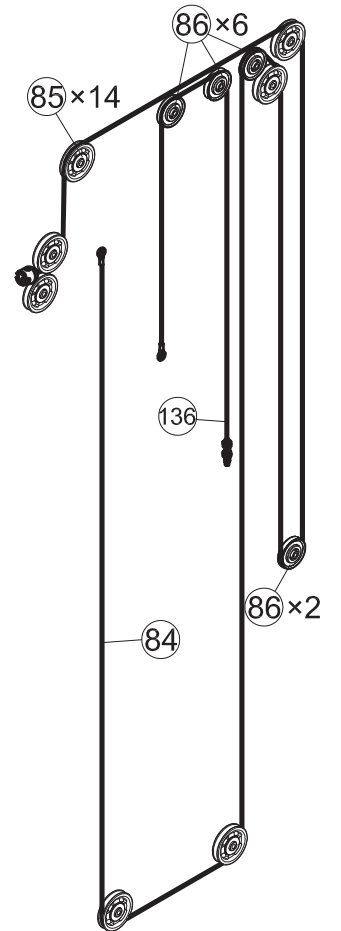
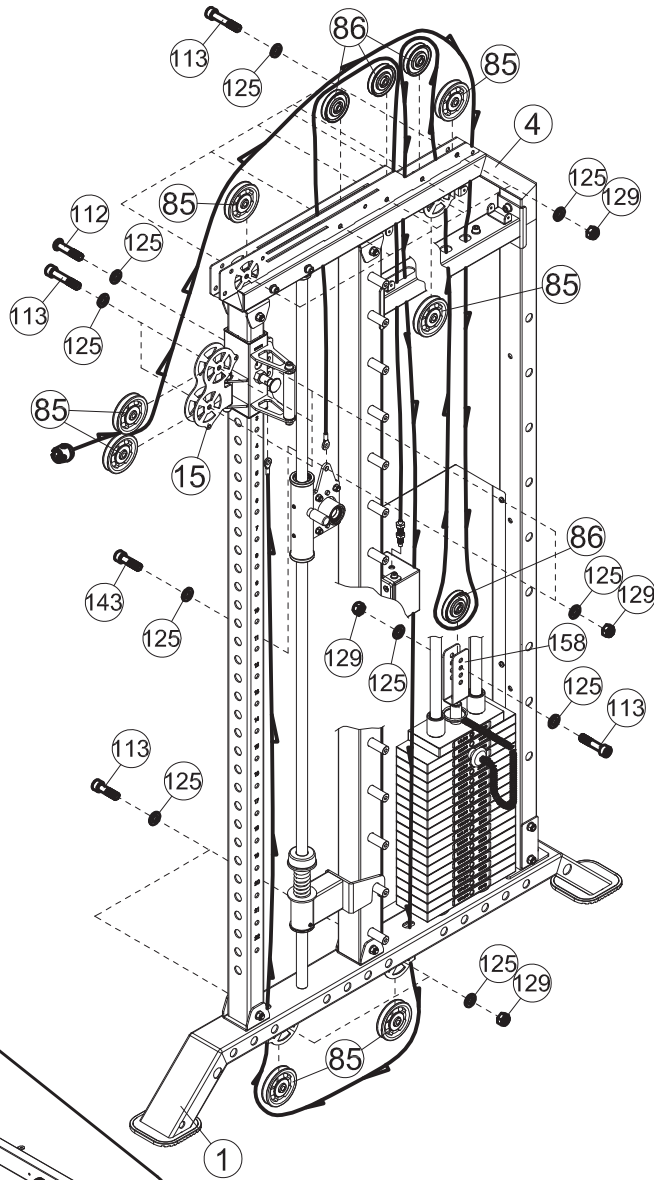
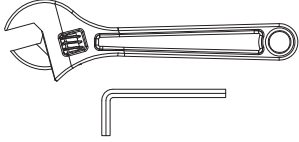



113		x22	M10x45	125		x52	Φ10
112		x2	M10x35	129		x26	M10
143		x2	M10x25				



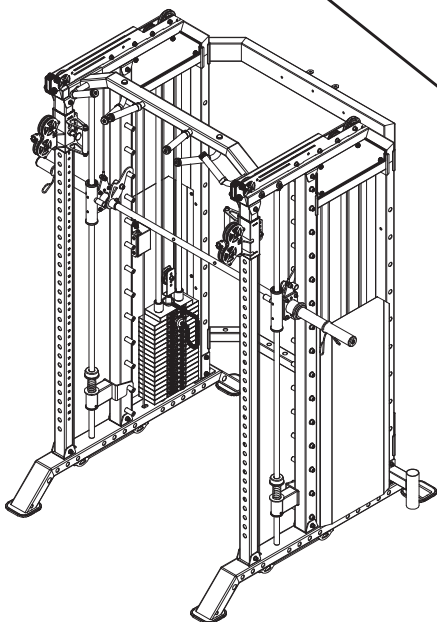
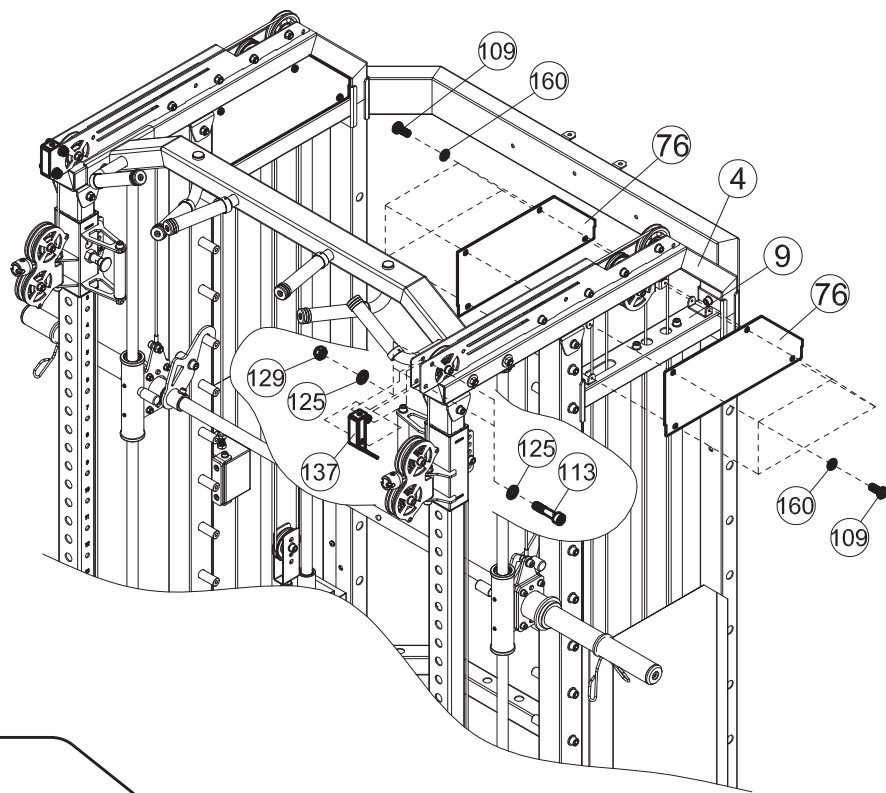
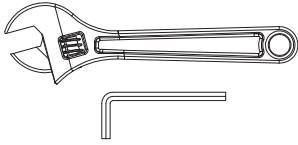



113		x4	M10x45	109		x16	M6x15
125		x8	Φ10	160		x16	Φ6
129		x4	M10				

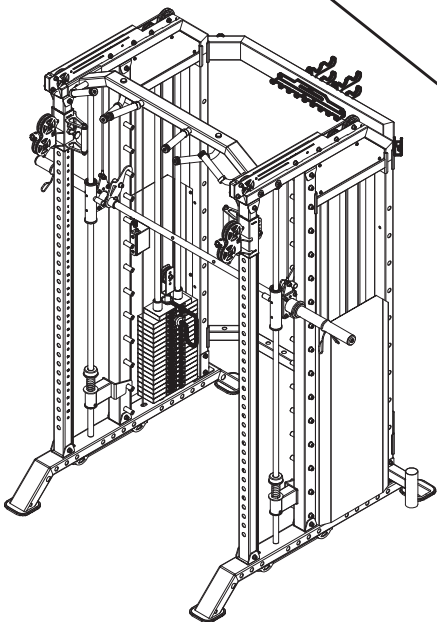
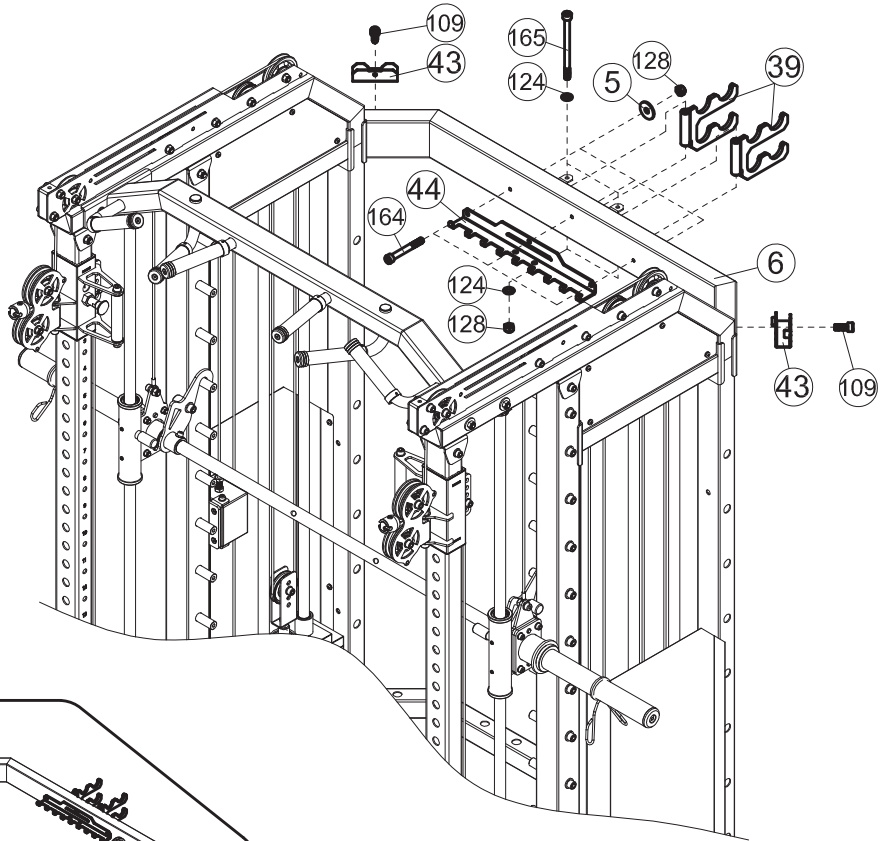
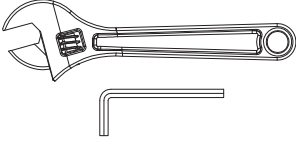

164		x3	M8x65	124		x4	Φ8
165		x2	M8x110	128		x5	M8
109		x2	M6x15	5		x3	Φ28xΦ8.5



- |     |   |    |        |     |  |    |         |
|-----|---|----|--------|-----|--|----|---------|
| ①①① |  | x6 | M10x20 | ①②⑤ |  | x6 | Φ10     |
| ①②① |  | x4 | M12x25 | ③⑥  |  | x4 | φ38xφ13 |
| ①②② |  | x6 | M10x20 |     |  |    |         |

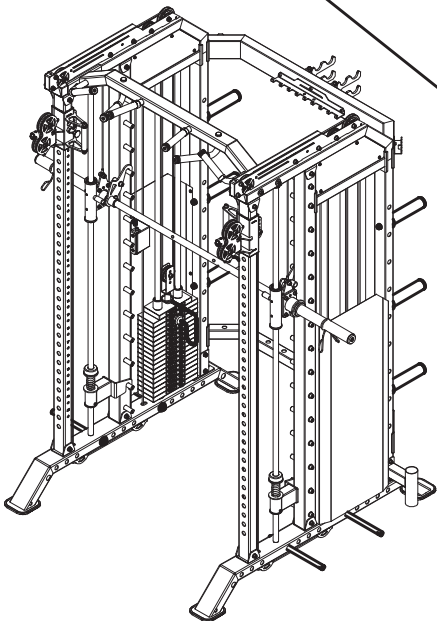
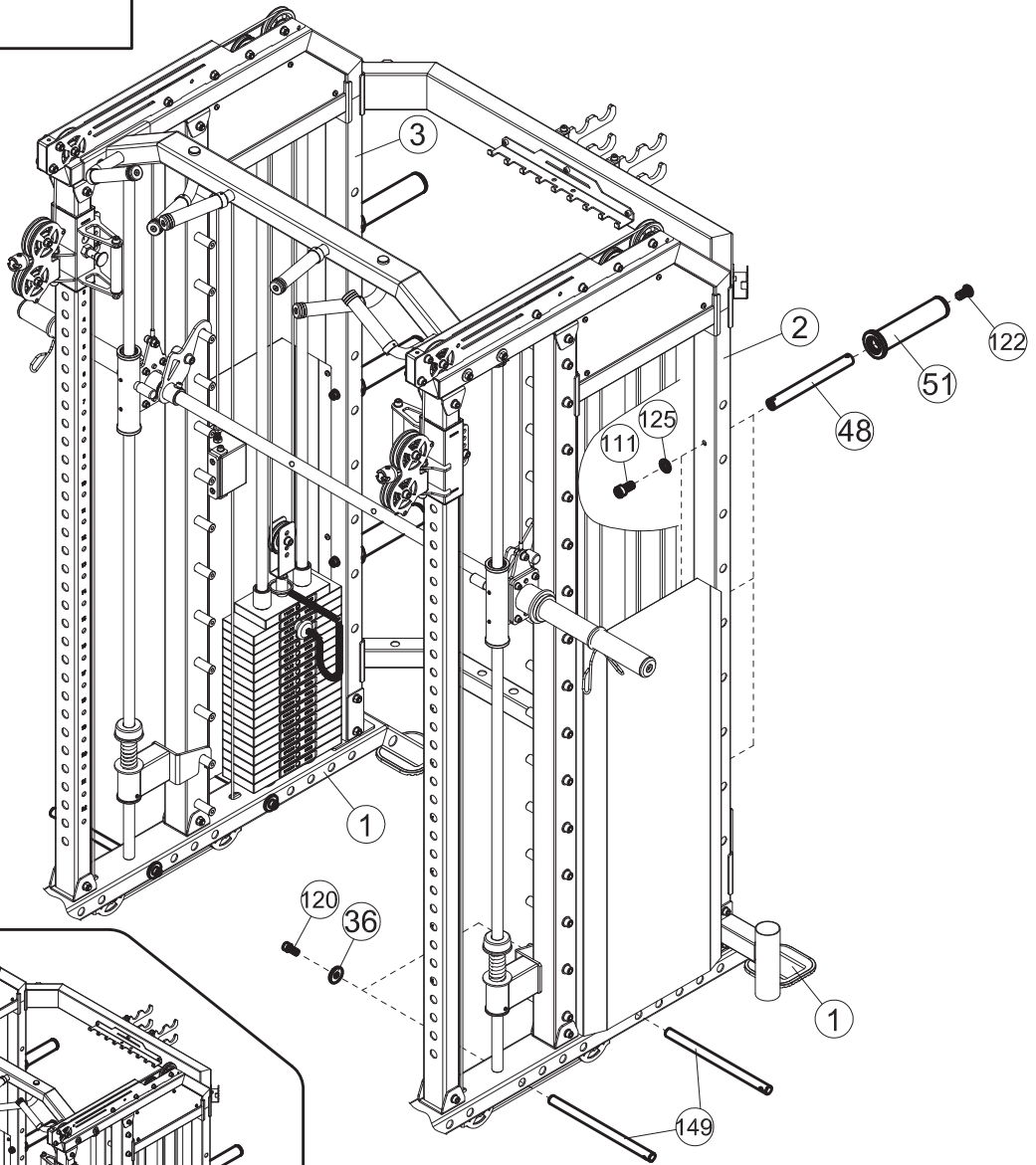
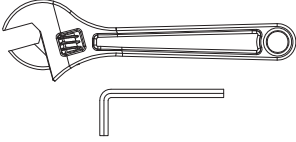

(121)

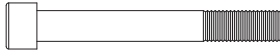

×1 M12×95

(127)



×2 Φ12

(130)



×1 M12

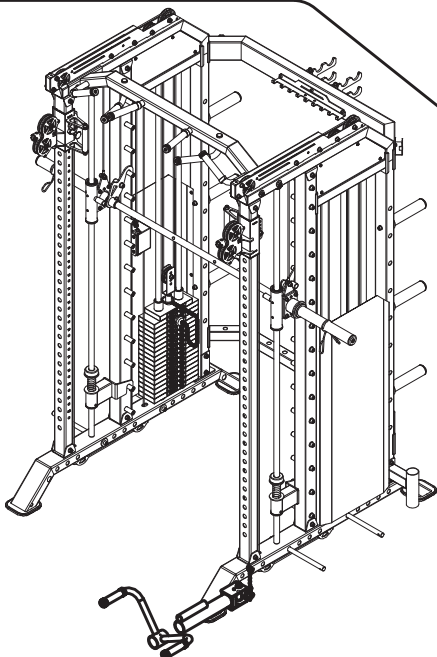
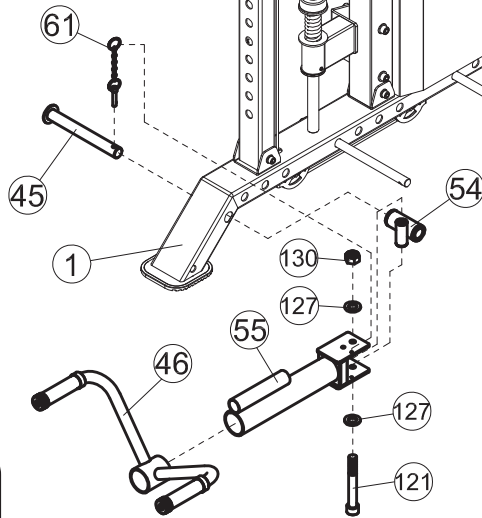
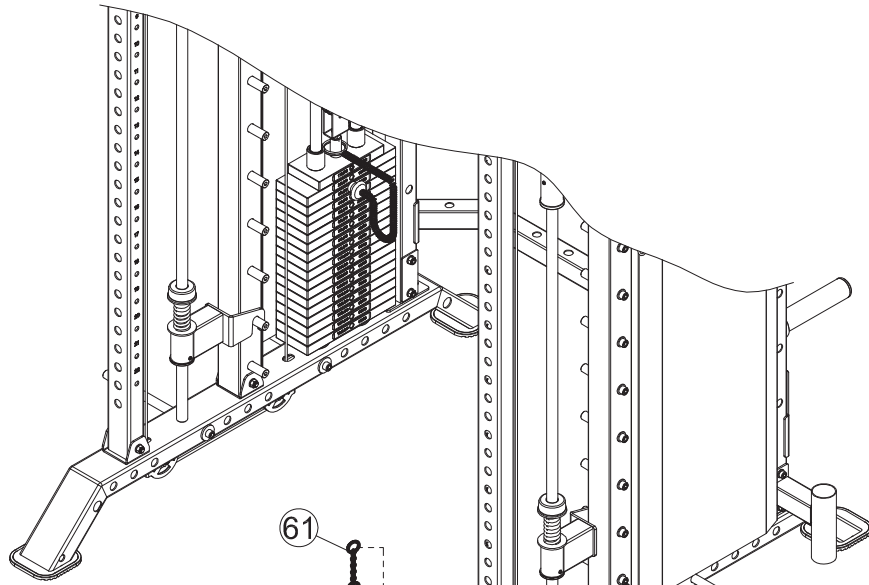
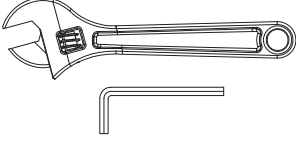

119

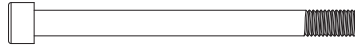

x1 M10x125

125



x2 Φ10

129



x1 M10

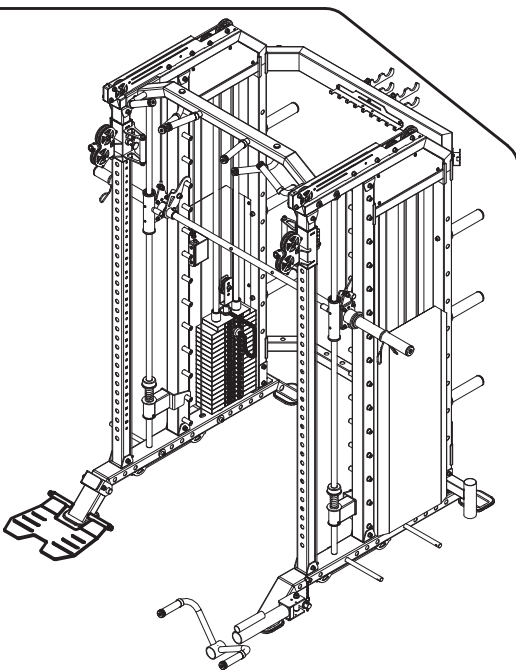
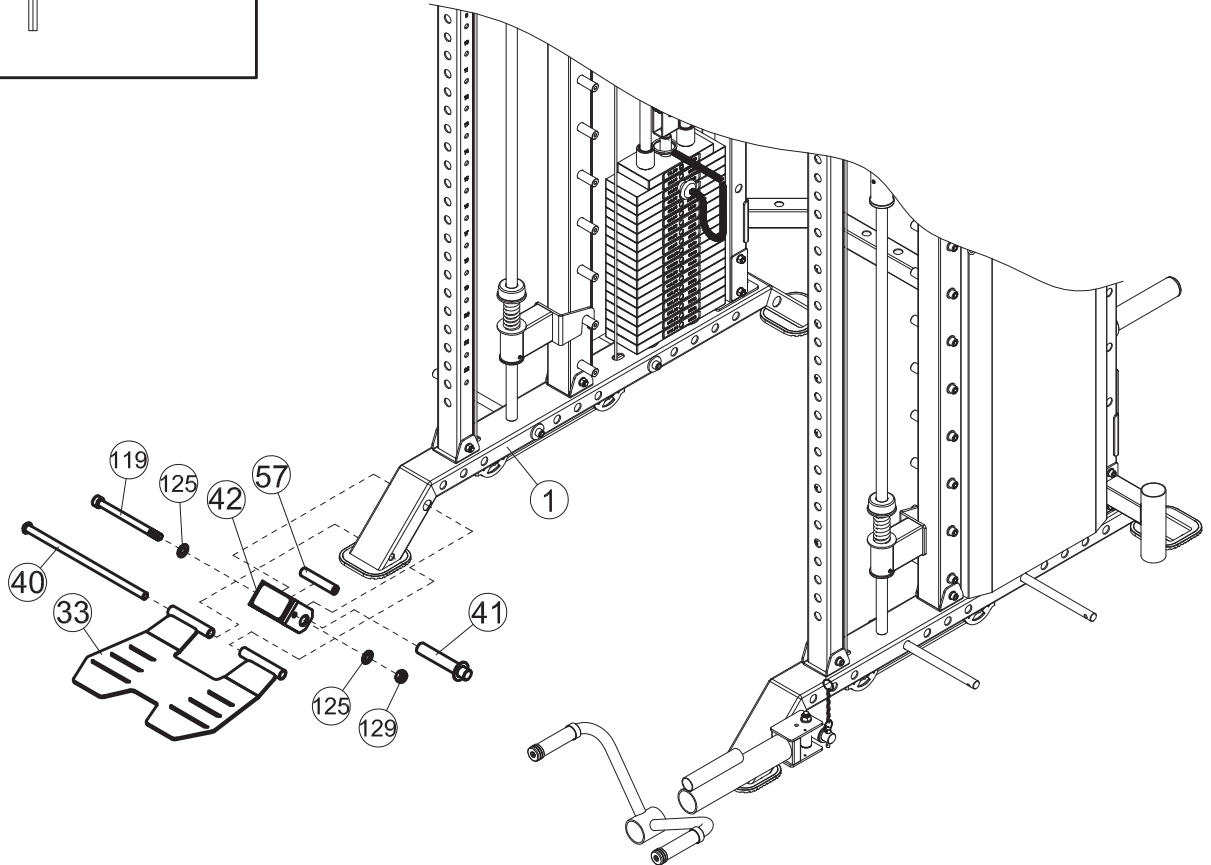
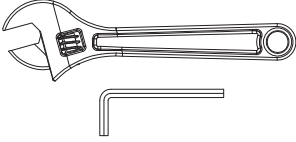

133



x2 M8x20

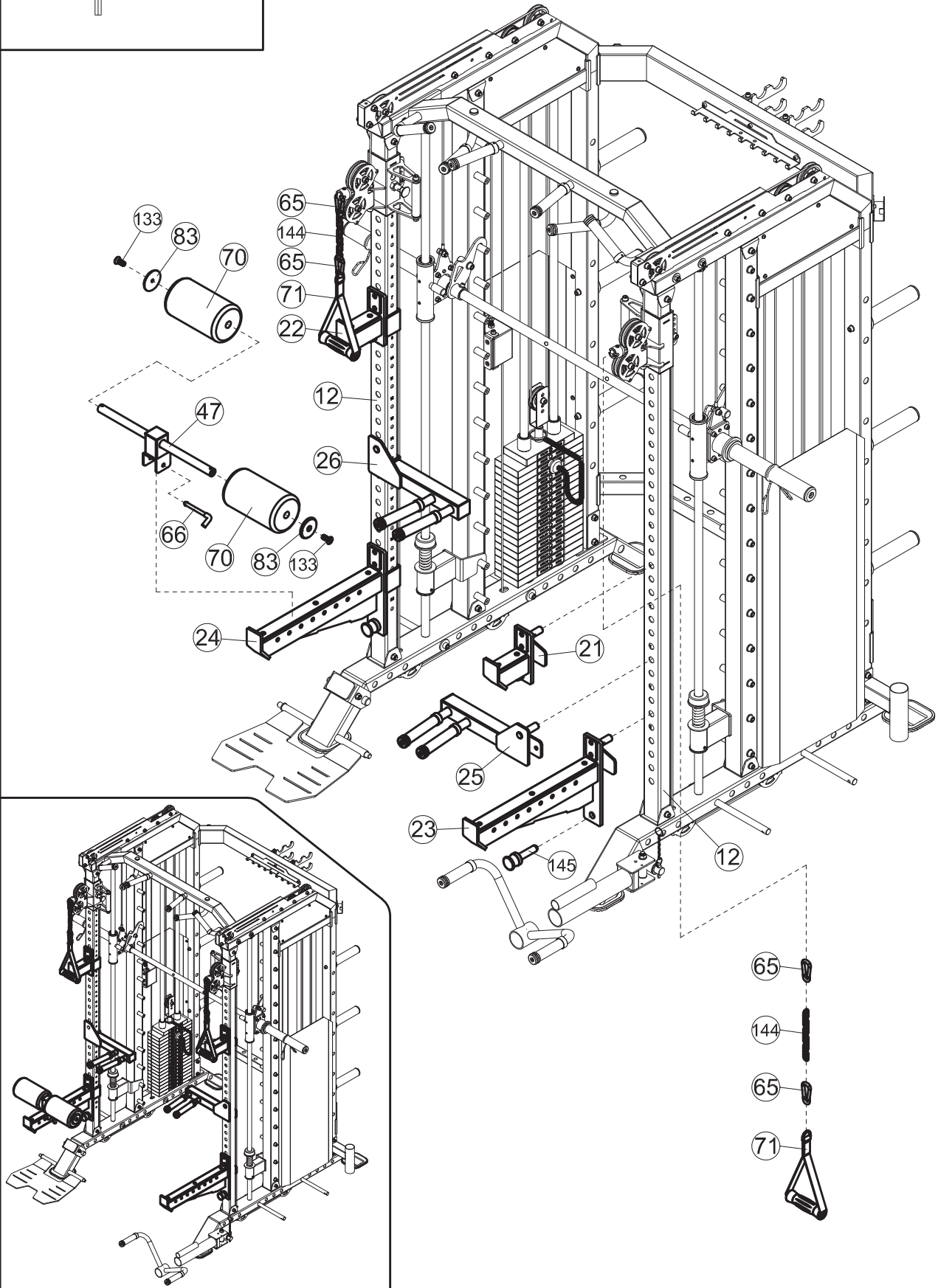
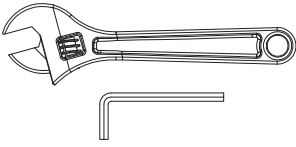

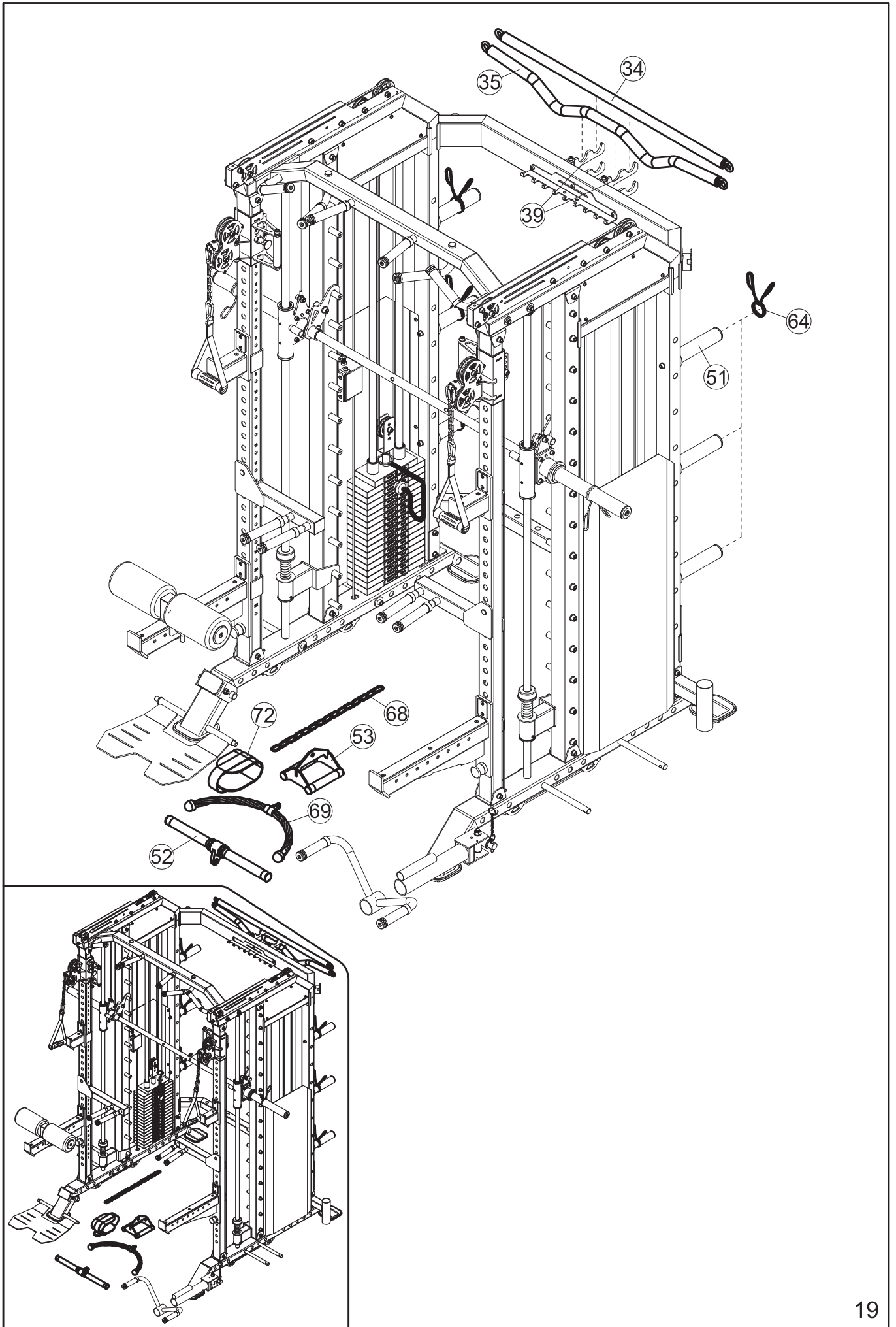

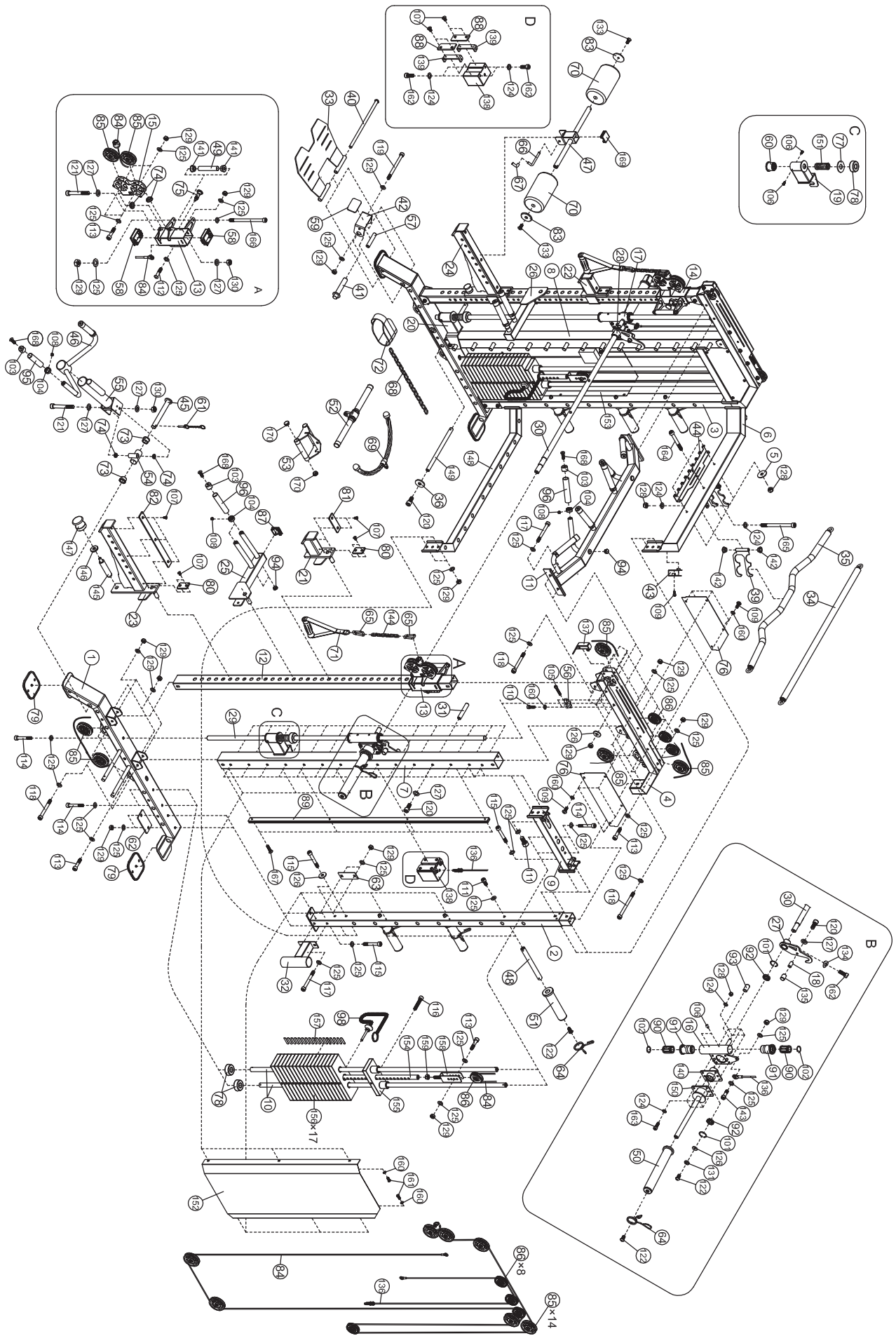

## PARTS LIST

KEY NO.	PART DESCRIPTION	SPEC	QTY
1	Base Frame		2
2	Rear Post L		1
3	Rear Post R		1
4	Top Frame		2
5	Washer	Φ28×Φ8.5×2	3
6	Connecting Frame Rear		1
7	Intermediate Stand L		1
8	Intermediate Stand R		1
9	Upper connecting frame		2
10	Guide Rod Rear		4
11	Horizontal bar		1
12	Guide Shaft	□50×70×3×1960	2
13	Sliding frame L		1
14	Sliding frame R		1
15	Pulley Case		2
16	Mobile rack L		1
17	Mobile rack R		1
18	Support shaft	Φ18×32×M12	2
19	Safety hook Bracket L		1
20	Safety hook Bracket R		1
21	Short Safety Rack L		1
22	Short Safety Rack R		1
23	Long Safety Rack L		1
24	Long Safety Rack R		1
25	Dip Bar L		1
26	Dip Bar R		1
27	Hanging Bar L		1
28	Hanging Bar R		1
29	Guide rod	Φ25×1960	2
30	Weight Rod	Φ30×1215×M10×M8	1
31	Hanging post	Φ20×115	30
32	Barbell Socket		2
33	Foot Pedal Set		1
34	Straight Bar	L=1115mm	1
35	Cambered Bar	L=1150mm	1
36	Washer	Φ38×Φ13×4	4
37			
38			
39	Hangre		2
40	Rotating Shaft		1
41	Fixed pedestal		1
42	Limit bracket	101×85×60×5	1

## PARTS LIST

KEY NO.	PART DESCRIPTION	SPEC	QTY
43	Hangre	100×37×38×27×10×2	2
44	Long hangre	50×50×15×415×3	1
45	Rotating Shaft		1
46	Handle		1
47	FOAM Frame		1
48	Weights Stow Rod	Φ25×250	6
49	Handle tube	Φ25×2×125	2
50	Long Spacer		2
51	Short Spacer		6
52	Small grip frame	L=480mm	1
53	V-type handle		1
54	Spacer		1
55	Rotating Frame		1
56	Fixed seat	70×42×24×M5	2
57	Spacer	Φ20×Φ10.5×101	1
58	Slide Guide	□60×80×2×□50×70	4
59	Rubber Stopper	95×55×5	1
60	Safety hook Bracket Guides	Φ55×Φ46×Φ27×41	2
61	Pop pin		1
62	Bracket	130×70×3	2
63	Bracket	120×50×3	2
64	Spring Clip	Φ47	8
65	Hook	Φ8	4
66	L spring pins	Φ10×115	1
67	Rubber sleeve	Φ13×Φ9.5×58	1
68	15-Joint Chain		1
69	Rope		1
70	FOAM	Φ125×Φ22×215	2
71	Nylon Strap Iso-Handle	L=245mm	2
72	Ankle Strap		1
73	Bushing	Φ38×Φ34×Φ25×22	2
74	Bushing	Φ25×Φ21.8×Φ12.2×8	6
75	Moving Lock Pin		2
76	Protective cover	435×178×1	4
77	Bracket	Φ65×Φ27×4	2
78	Rubber Stopper	Φ62×Φ24.5×25	6
79	Floor End Cap	□135×135×8	4
80	Rack Liner	70×45×5	4
81	Rack Liner	120×45×5	2
82	Rack Liner	505×45×5	2
83	plate	Φ68×5.7	2
84	Double pull cable	L=8560mm ( Φ5 )	2

## PARTS LIST

KEY NO.	PART DESCRIPTION	SPEC	QTY
85	Pulley with Bearings	Φ95×Φ10	14
86	Small Pulley with Bearing	Φ72	8
87	Rectangular End Cap	□50	2
88	Rack Liner	110×45×6	4
89	Guide	15×30×2×1690	2
90	Linear Motion Bearing	LB254058	4
91	Sliding Rod Guide	Φ55×Φ46×Φ40×73	4
92	Deep groove ball bearing	61905	4
93	Tube End Cap	Φ19×42	2
94	Rectangular End Cap	Φ25	10
95	Dips Handle	Φ24.5×3×120	2
96	Dips Handle	Φ24.5×3×140	10
97			
98	Weight Selector Pin		2
99			
100			
101	Hole circlip	42	4
102	Hole circlip	d0=40	4
103	Decorative cover	Φ34.5×Φ6.5×19	12
104	Retaining ring	Φ35×Φ26.2×14.5×M6	12
105	Hexagon socket button head screws	M5×25	2
106	Screw	ST4.0×9	8
107	Hexagon socket countersunk head screws	M6×10	26
108	Set screw	M6×6	12
109	Hexagon socket button head screws	M6×15	18
110	Hexagon socket button head screws	M6×30	4
111	Hexagon socket button head screws	M10×20	10
112	Allen Bolt	M10×35	2
113	Hexagon socket button head screws	M10×45	26
114	Hexagon socket button head screws	M10×65	10
115	Hexagon socket button head screws	M10×70	12
116	Hexagon socket button head screws	M10×55	2
117	Hexagon socket button head screws	M10×90	8
118	Hexagon socket button head screws	M10×95	8
119	Hexagon socket button head screws	M10×125	1
120	Hexagon socket button head screws	M12×25	36
121	Hexagon socket button head screws	M12×95	3
122	Allen Bolt	M10×20	10
123			
124	Washer	8	28
125	Washer	10	130
126	Washer	Φ30×Φ10.5×2.5	10

## PARTS LIST

KEY NO.	PART DESCRIPTION	SPEC	QTY
127	Washer	12	38
128	Nut	M8	13
129	Nut	M10	57
130	Nut	M12	3
131	Washer	10	2
132			
133	Hexagon socket countersunk head screws	M8×20	2
134	Washer	20×R20×Φ9	2
135	Cushion cover	Φ18×Φ25×30	2
136	Balance cable	L=2240mm ( Φ5 )	2
137	Decorative cover		2
138	Balance piece	105×80×110	2
139	U-shaped seat	110×30×30×5	4
140	Bearing frame		2
141	Bushing	Φ25×Φ21.8×Φ10.5×12	4
142	Bushing	Φ16×Φ12×Φ8.3×7.5	4
143	Hexagon socket button head screws	M10×25	2
144	6-Joint Chain		2
145	spring pins	Φ20×100×M10	2
146	Washer	Φ30×Φ10.5×5	2
147	Handle	Φ45×Φ40×40×M10	2
148	Connecting Frame Rear		1
149	Weights Stow Rod	Φ20×320	4
150	Weights Stow Rod		2
151	Spring	Φ43×Φ27×Φ8×80	2
152	Weight Stack Cover L	1100×438×60×1.0	1
153	Weight Stack Cover R	1100×438×60×1.0	1
154	Selector Rod	Φ25×513 ( 17+1 )	2
155	Top Weight Plate	205×100×72	2
156	Weight Plate	280×100×25.4 ( 5KG )	34
157	Weight Plate Sticker ( 90kg )	119×17.5	2
158	Pulley Case		2
159	Hex nuts	M12	2
160	Washer	6	32
161	Cross recessed pan head screws	M6×16	12
162	Hexagon socket button head screws	M8×20	10
163	Hexagon socket button head screws	M8×30	8
164	Hexagon socket button head screws	M8×65	3
165	Hexagon socket button head screws	M8×110	2
166	Hexagon socket button head screws	M10×155	2
167	Hexagon socket countersunk head screws	M6×25	8
168	Hexagon socket countersunk head screws	M6×20	12

## PARTS LIST

<b>KEY NO.</b>	<b>PART DESCRIPTION</b>	<b>SPEC</b>	<b>QTY</b>
<b>169</b>	<b>Rectangular End Cap</b>	<b>□50</b>	<b>1</b>
<b>170</b>	<b>Rectangular End Cap</b>	<b>Φ28</b>	<b>4</b>
	<b>Allen wrench</b>	<b>3#</b>	<b>1</b>
	<b>Allen wrench</b>	<b>4#</b>	<b>1</b>
	<b>Allen wrench</b>	<b>5#</b>	<b>1</b>
	<b>Allen wrench</b>	<b>6#</b>	<b>1</b>
	<b>Allen wrench</b>	<b>8#</b>	<b>1</b>
	<b>Allen wrench</b>	<b>10#</b>	<b>1</b>