

FRENCH FITNESS

FFN-ASP

French Fitness Napa P/L Angled Squat Press

ASSEMBLY MANUAL

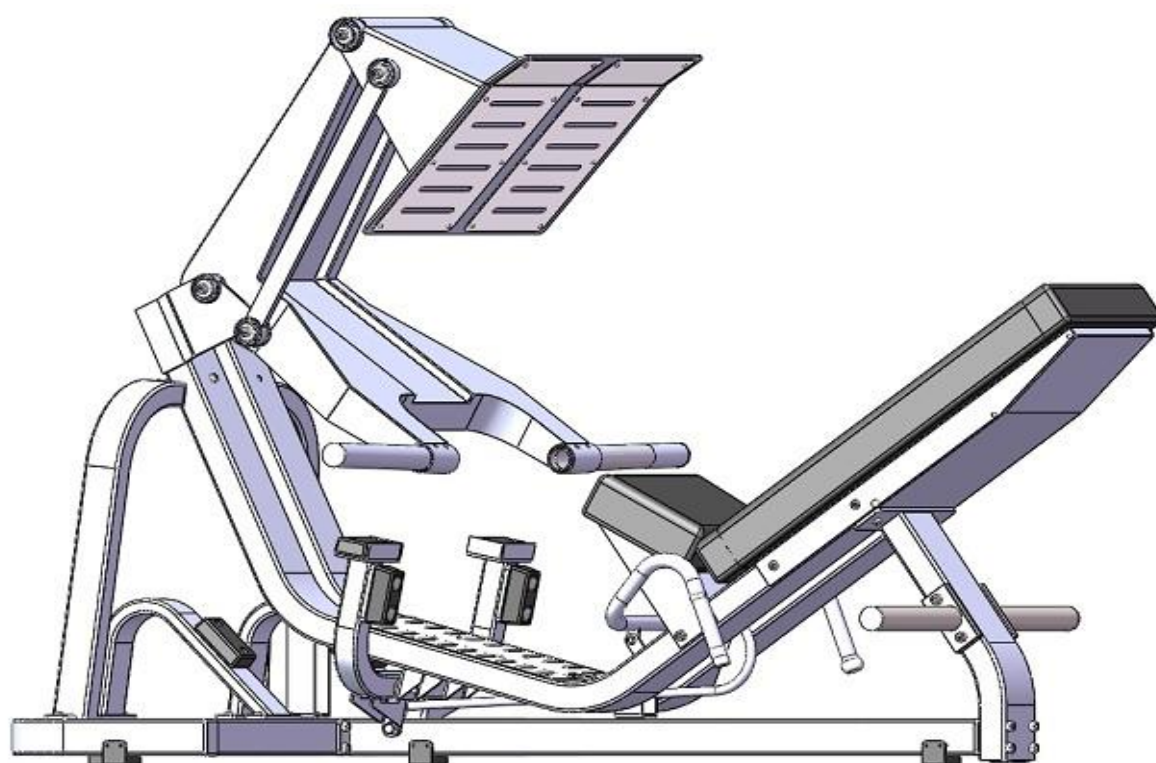

FEATURES

- Large foot plate increases the variety of exercise possible.
- Footplate is angled perfectly to maintain a comfortable ankle angle throughout the press.
- The position of the weight plates provides optimal resistance as the legs move to full extension.
- Center footplate puts the un-involved leg in a comfortable position to facilitate uni-lateral training.
- Two built-in weight horns hold multiple plate sizes.

TECH SPECS









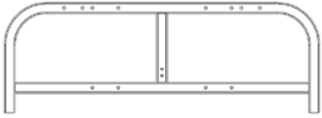
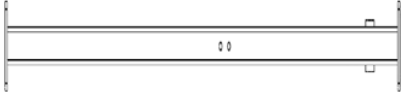

- Weight: 473.9lb (215kg)
- Dimensions: 57"L x 82.6"W x 54.5"H(1450mm x 2100mm x 1385mm)

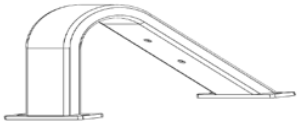
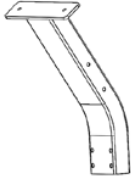
WARRANTY

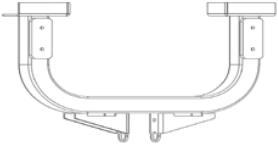
- **10 Years Parts, 1 Year Labor (Commercial)**

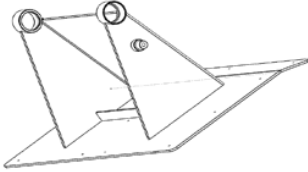
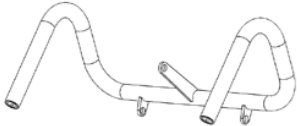
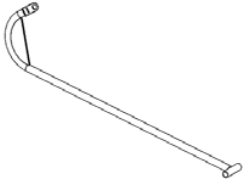
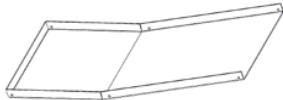
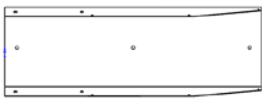
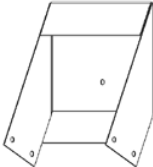

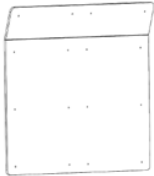

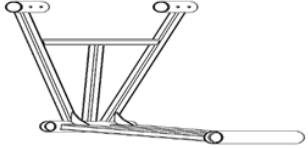



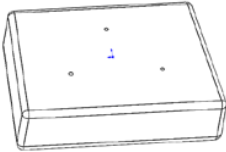

PARTS LIST

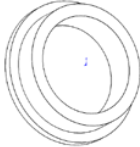
Individual packaging

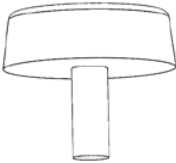
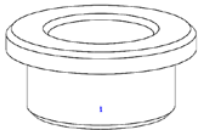
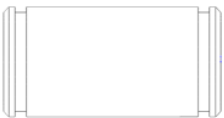
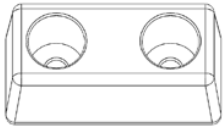
								
NO.1	Underframe welding part *1 PC	NO.2	Connecting Components * 1 PC	NO.3	Support Tube Welding Part * 1 PC			
								
NO.4	Limit support components *2 PCS	NO.5	Elbow support welding * 1 PC	NO.6	Connect double pipe * 1 PC			
								
NO.7	Retaining components * 1 PC	NO.8	Linkage components * 1 PC	NO.9	Forced pedal assembly part *1 PC			
								
NO.10	Handle welding components * 1 PC	NO.11	Adjusting and transmission components * 1 PC	NO.12	Back cover sheet metal * 1 PC			
								
NO.13	Backrest sheet metal * 1 PC	NO.14	Cushion sheet metal * 1 PC	NO.15	0312 Anti-slip board * 1 PC			
								
NO.16	Pedal * 1 PC	NO.17	0109 Anti-slip board * 1 PC	NO.18	Sheet metal welding group * 1 PC			

PARTS LIST

Assembly parts

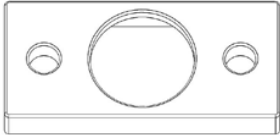
					
NO.29	Cushion*1pc	NO.30	Backrest*1pc	NO.31	Nylon sleeve*2pcs
					
NO.32	Axis of rotation*1pc	NO.33	Damping positioning block*2pcs	NO.34	Copper sets*6pcs
					
NO.35	Handle rotation axis*2pcs	NO.36	Hard rubber*2pcs	NO.37	MWH damping cushion*4pcs
					
NO.38	Stainless steel pcat*2pcs	NO.39	0308 Axis*1pc	NO.40	0309 Axis*1pc
					
NO.41	Stainless steel Hanging piece *2pcs	NO.42	Rubber sleeve*2pcs		

Assembly parts

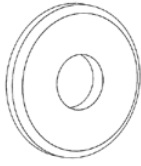

NO.47

Gasket*4pcs

Blister pack screw schedule-5 (standard parts)

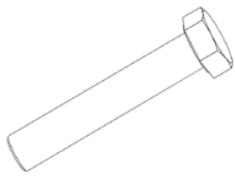

A

Hexagon head screws
M12*80

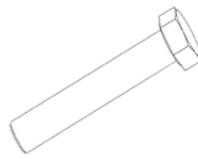

B

Hexagon head screws
M10*90

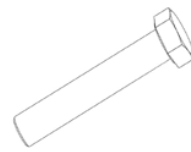

C

Hexagon socket flat head screws
M12*90

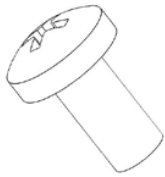

D

Cross recessed round head
screws M4*8

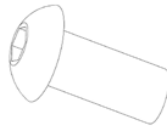

E

Hexagon socket flat head
screws M10*25

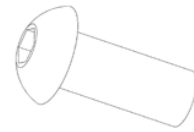

F

Hexagon socket flat head screws
M10*30



G

Locknut M10



H

Flat gasket M12



I

Flat gasket M10



J

Cross recessed round head
screws M6*8



K

Locknut M12

MAIN FRAME ASSEMBLY STEPS

Step NO	Item NO	Name	Quantity	Item NO	Name	Quantity
1	NO.1	Underframe welding part	1	L	Ø10 Flat gasket	2
	NO.2	Connecting Components	1	K	Locknut M12	8
	NO.3	Support Tube Welding Part	1			
	C	Hexagon socket flat head screws M12*90	8			
Tools/Equipment		6# Allen screw driver, w rench				

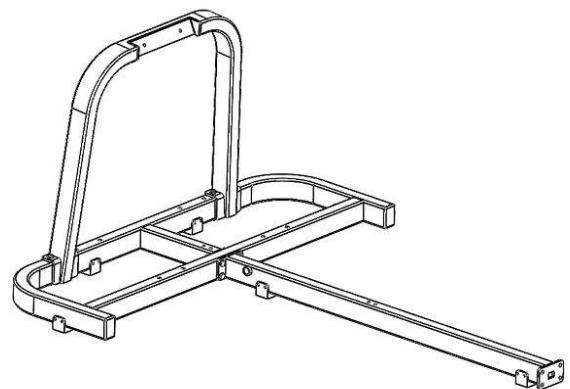
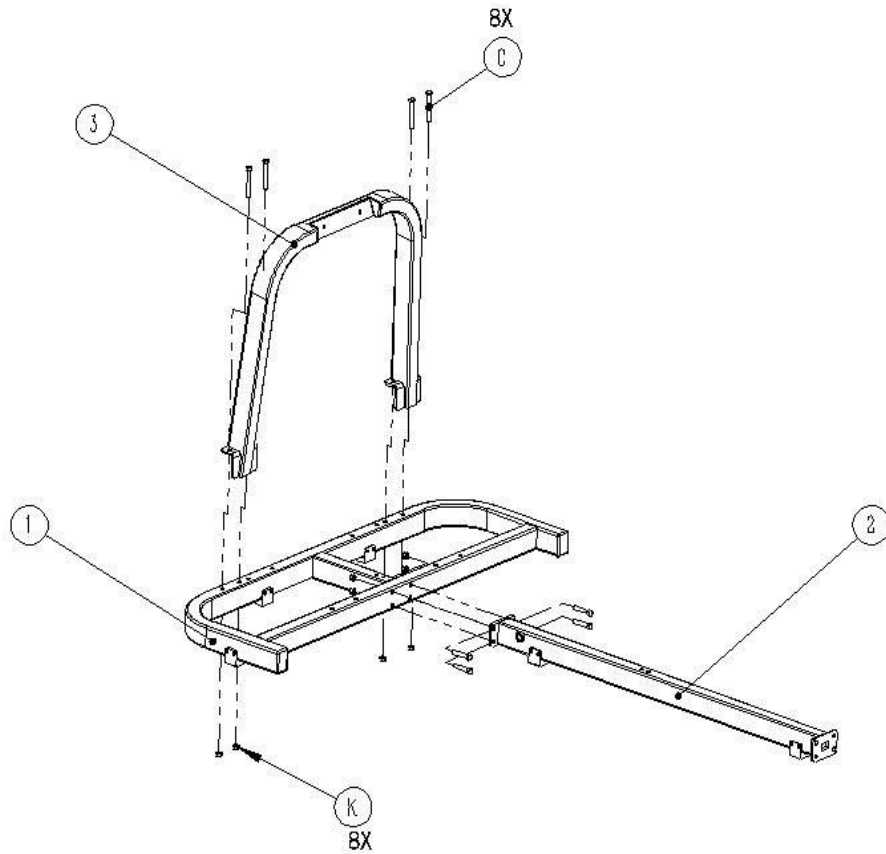

Step NO	Item NO	Name	Quantity	Item NO	Name	Quantity
2	NO.4	Limit support components	2			
	NO.5	Elbow support w elding	1			
	C	Hexagon socket flat head screws M12*90	12			
	K	Locknut M12	12			
Tools/Equipment		6# Allen screwdriver, wrench				

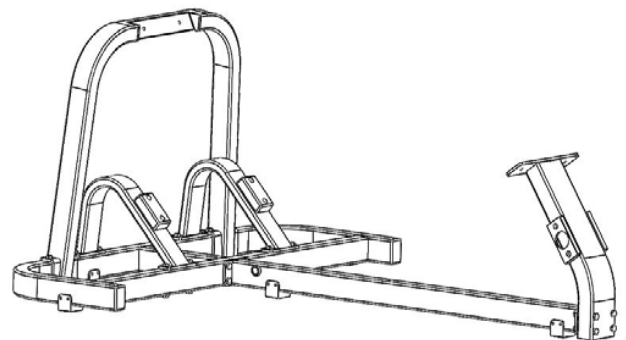
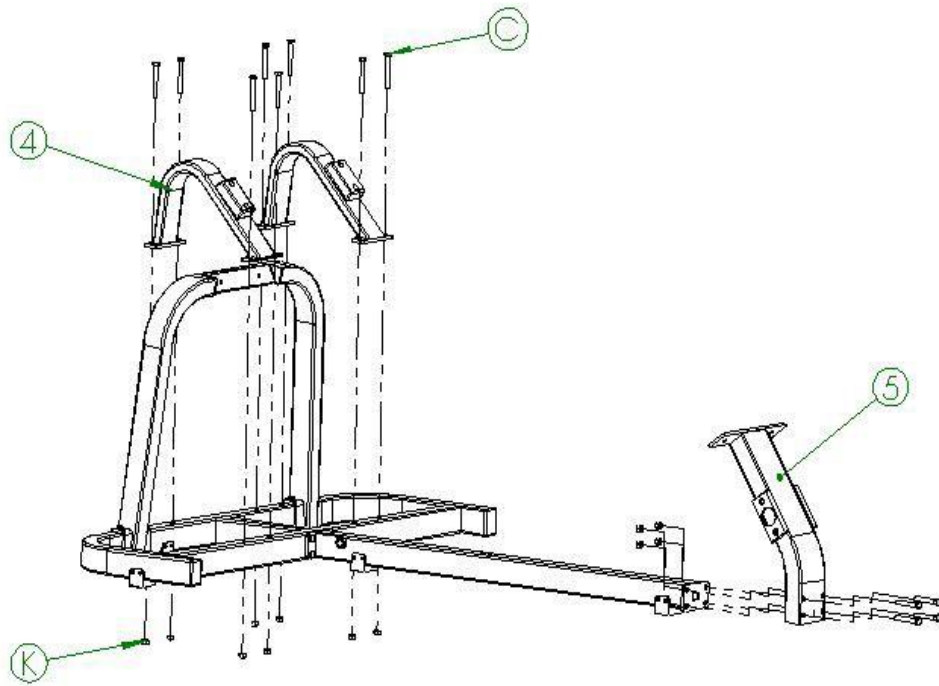

Main frame assembly steps

Step NO	Item NO	Name	Quantity	Item NO	Name	Quantity
3	NO.7	Retaining components	1			
	NO.32	Axis of rotation	1			
Tools/Equipment						

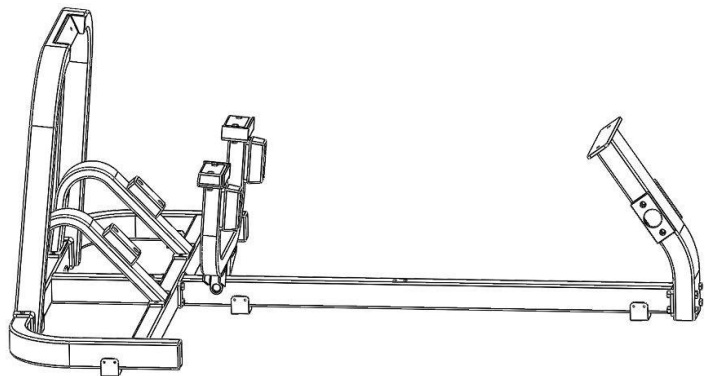
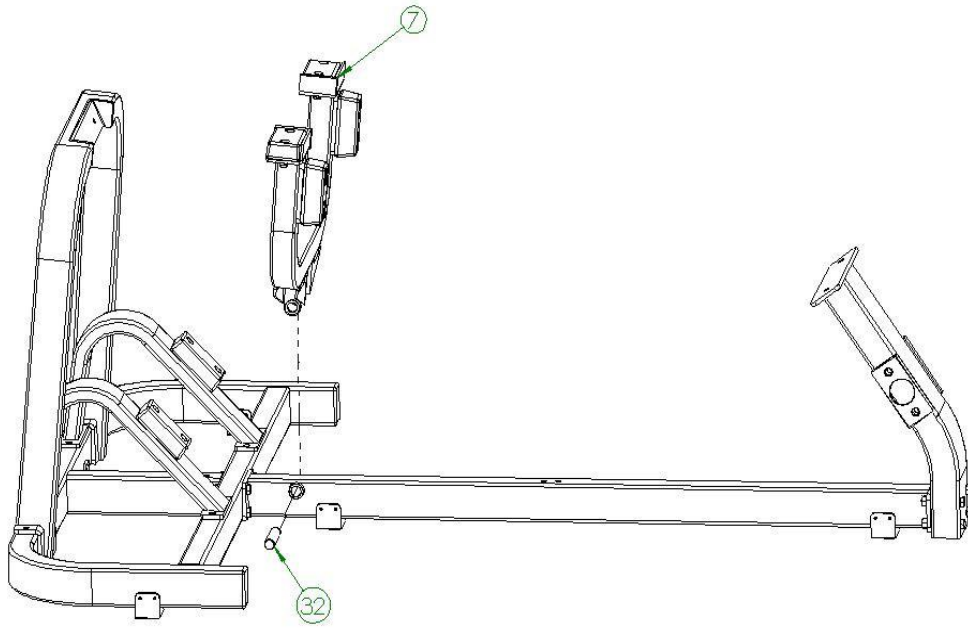

Step NO	Item NO	Name	Quantity	Item NO	Name	Quantity
4	NO.6	Connect double pipe	1			
	NO.11	Adjusting and transmission components	1			
Tools/Equipment						

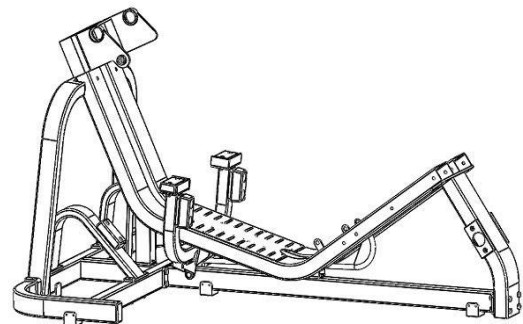
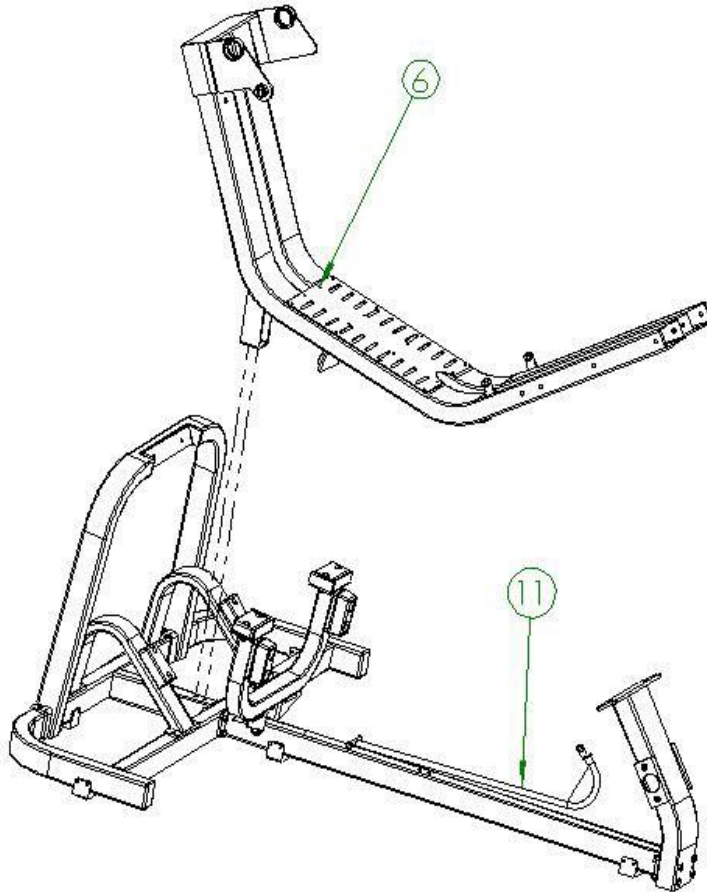

Main frame assembly steps

Step NO	Item NO	Name	Quantity	Item NO	Name	Quantity
5	NO.10	Handle welding components	1			
	NO.18	Sheet metal welding group	1			
Tools/Equipment		6# Allen screw driver				

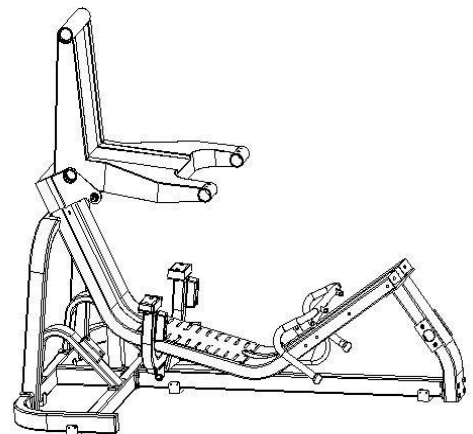
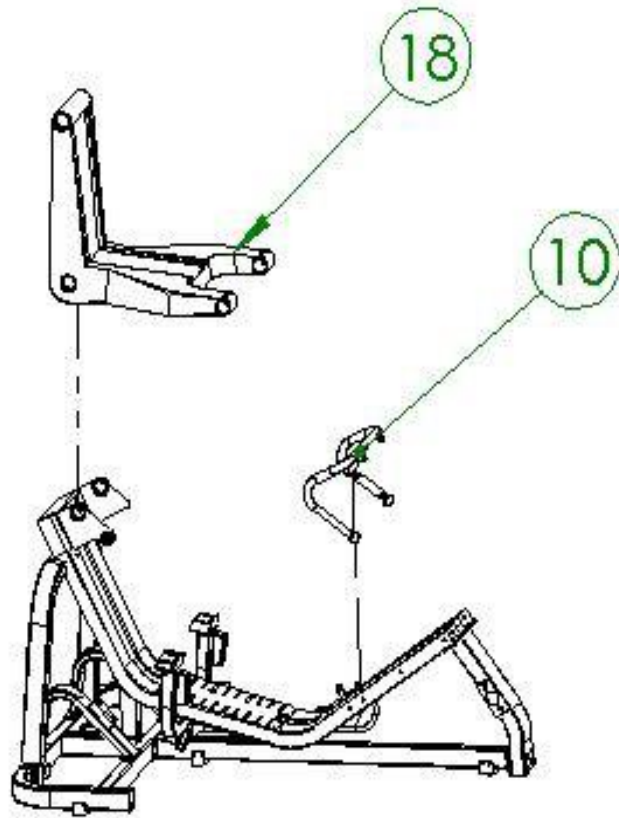

Step NO	Item NO	Name	Quantity	Item NO	Name	Quantity	
6	NO.9	Forced pedal assembly part	1				
	NO.8	Linkage components	1				
	NO.14	Cushion sheet metal	1				
Tools/Equipment		6# Allen screw driver					

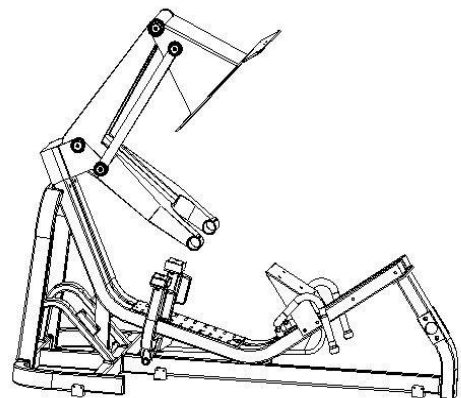
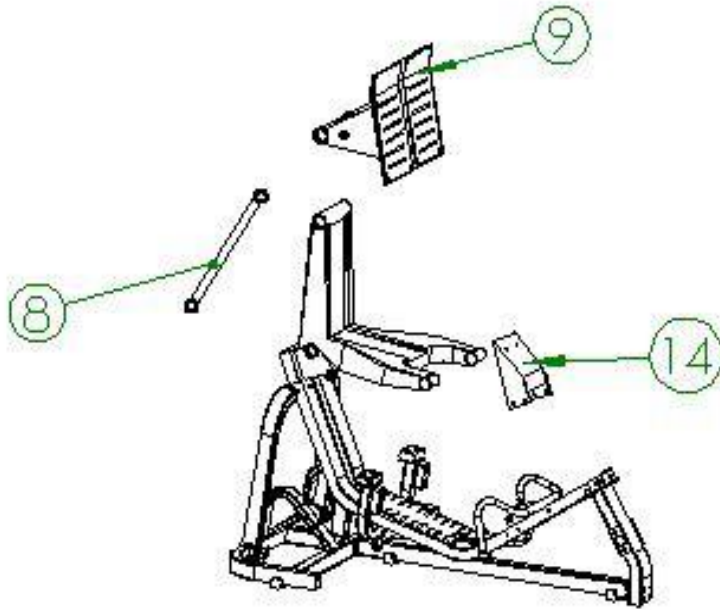

Step NO	Item NO	Name	Quantity	Item NO	Name	Quantity
7	NO.12	Back cover sheet metal	1			
	NO.13	Backrest sheet metal	1			
Tools/Equipment		6# Allen screw driver				

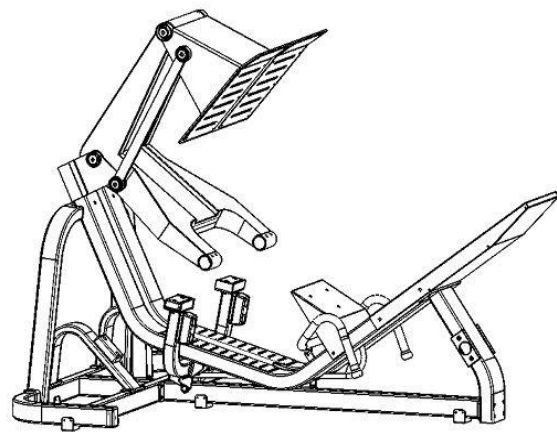
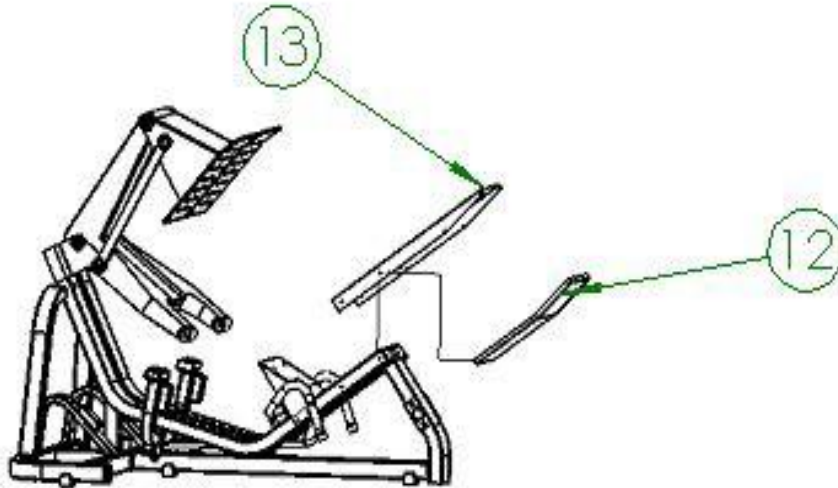

Step NO	Item NO	Name	Quantity	Item NO	Name	Quantity	
8	NO.29	Cushion	1				
	NO.30	Backrest	1				
	NO.41	Stainless steel Hanging piece	4				
Tools/Equipment		6# Allen screw driver					

