

FRENCH FITNESS

FFN-SM / FFM-SM

FRENCH FITNESS NAPA & MARIN
SMITH MACHINE

ASSEMBLY MANUAL



OR



FEATURES

- Paint Color: Silver
- 11 gauge steel
- High quality steel tube ASTM A36 with 50 x 100 x 3mm and 40 x 80 x 3mm rectangle steel tube
- Tungsten Inert Gas (TIG) welding
- Electrostatic powder coating
- Open frame design and high head clearance
- Counterbalanced Smith Bar: Yes
- Crossbar support
- Fully shrouded track system
- Multiple press bar catches
- California Residents see Prop 65 WARNINGS

TECH SPECS

- Number of Weight Horns for Storage: 6
- Weight Horn Length: 12.5" (320 mm)
- Weight Horn Maximum Capacity: 661.3 lbs (300 KG)
- Smith Bar Weight: 46 lbs (21 KG)
- Smith Bar Length: 92.1" (2340 mm)
- Smith Bar Maximum Capacity: 661.3 lbs (300 KG)
- Machine Weight: 395 lbs (179 KG)
- Dimensions: 55.9"L x 84.2"W x 90.1"H (L:1420 mm, W:2140 mm, H:2290 mm)









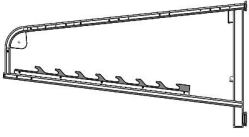
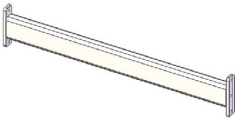
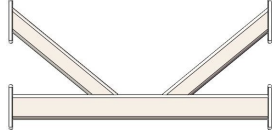

WARRANTY

10 Years Parts, 1 Year Labor (Commercial)

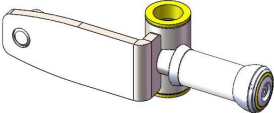
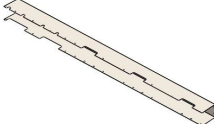
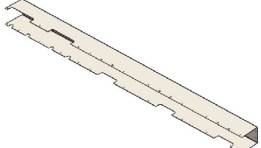
TABLE OF CONTENTS

PARTS LIST	4
ASSEMBLY STEPS	5

PARTS LIST

Parts list (Individually packaged)					
					
NO. 1	Large frame welding assembly*2PCS	NO. 2	Front connection assembly *1 PC	NO. 3	Rear connection components*1PC
					
NO. 4	Counterweight assembly*2 pcs	NO. 5	Gun barrel assembly *6 pcs	NO. 6	Push-up guide assembly*2 pcs
					
NO. 7	Promotional component*1 pc	NO. 8	Safety device assembly*2 pcs	NO. 9	Guard plate*1 pc
					
NO. 10	Guard plate-1*1 piece	NO. 11	Guide Rod*2pcs	NO. 12	Stainless steel gasket ring*2 pcs
					
NO. 13	Lock rope small column * 8 pcs	NO. 14	Rubber cover*2 pcs	NO. 15	Guide rod pads*6 pcs
					
NO. 16	Rubber cover*2 pcs				

ASSEMBLY STEPS

Step NO	Item NO	Name	Qty	Item NO	Name	Qty
1	NO. 1	Large frame assembly		A	M10*130 Cylindrical head screws	12
	NO. 2	Front connection assembly		B	Φ10Gasket	12
	NO. 3	Rear connection components		C	M10Anti-loosening nuts	12

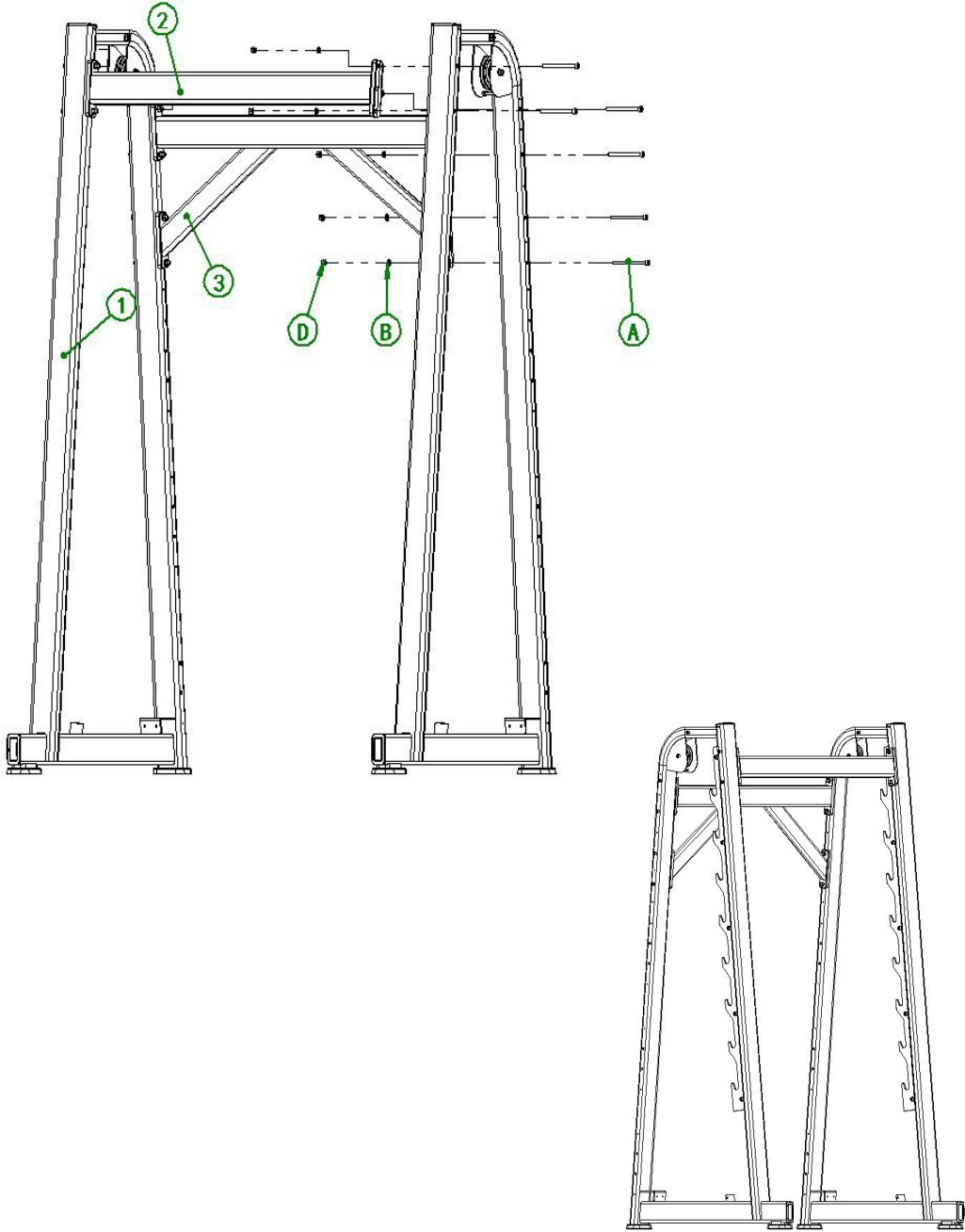

NO.1 Large frame welding assembly*2PCS

Step NO	Item NO	Name	Qty	Item NO	Name	Qty
	NO. 20	Stainless steel hooks	1	NO. 24	Φ105pulley	1
	NO. 21	Spacer	2	NO. 25	Pipe Plug	2
	NO. 22	New foot mats	2	F	M10*90Cylindrical head screws	1
	NO. 23	Foot Pad Cap Guard	2	G	M10*115Cylindrical head screws	1
	H	M10X25Cylindrical head screws	4	C	M10Anti-loosening nuts	2
				B	Φ10Gasket	6

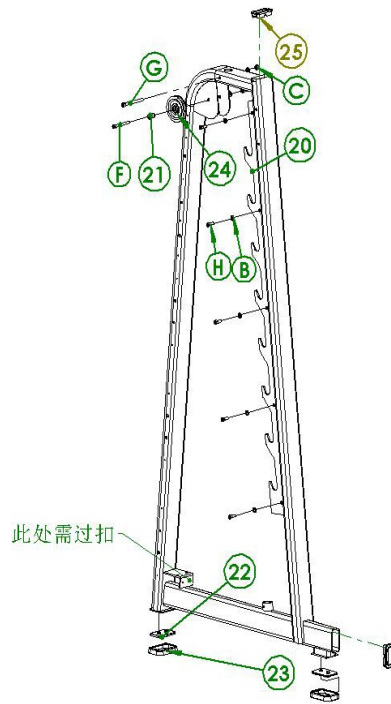

Step NO	Item NO	Name	Qty	Item NO	Name	Qty
	NO. 26	Cap front cover	1	J	M6*16Flat countersunk head screws	1
	NO. 27	Cap Back Cover	1	NO. 30	Aluminum cap	1
	NO. 28	Copper Bushing	2	NO. 31	Little yellow circle	1
	NO. 29	Φ25It can't be torn.	1	NO. 32	Aluminum cover	1
	NO. 34	Big Yellow Circle	1	NO. 35	Aluminum Ring	1

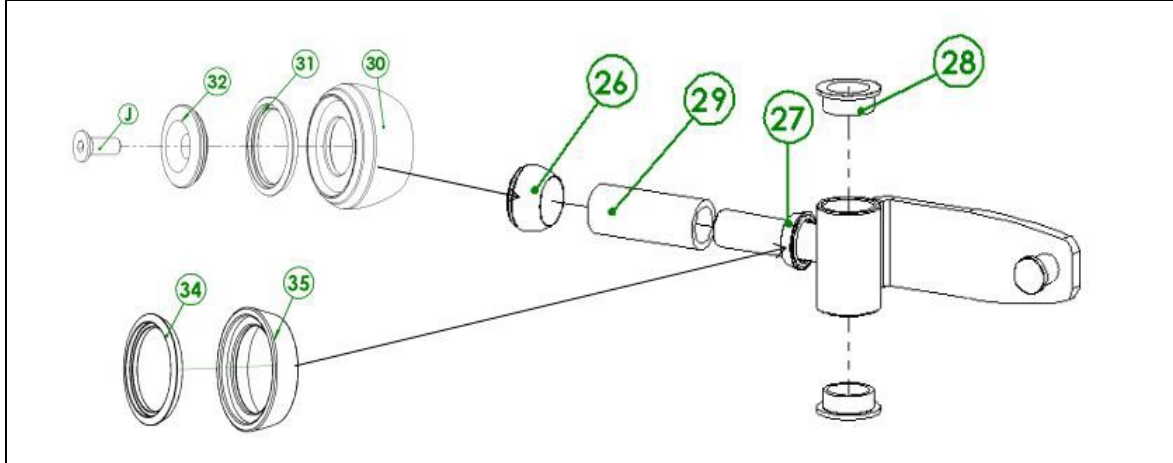

Assembly steps

Step NO	Item NO	Name	Qty	Item NO	Name	Qty
	NO. 6	Push-up guide assembly	2	NO. 11	Guide Rod	2
	NO. 7	Promotional components	1	NO. 15	Guide Rod Pads	6
	NO. 8	Fuse assembly	2			

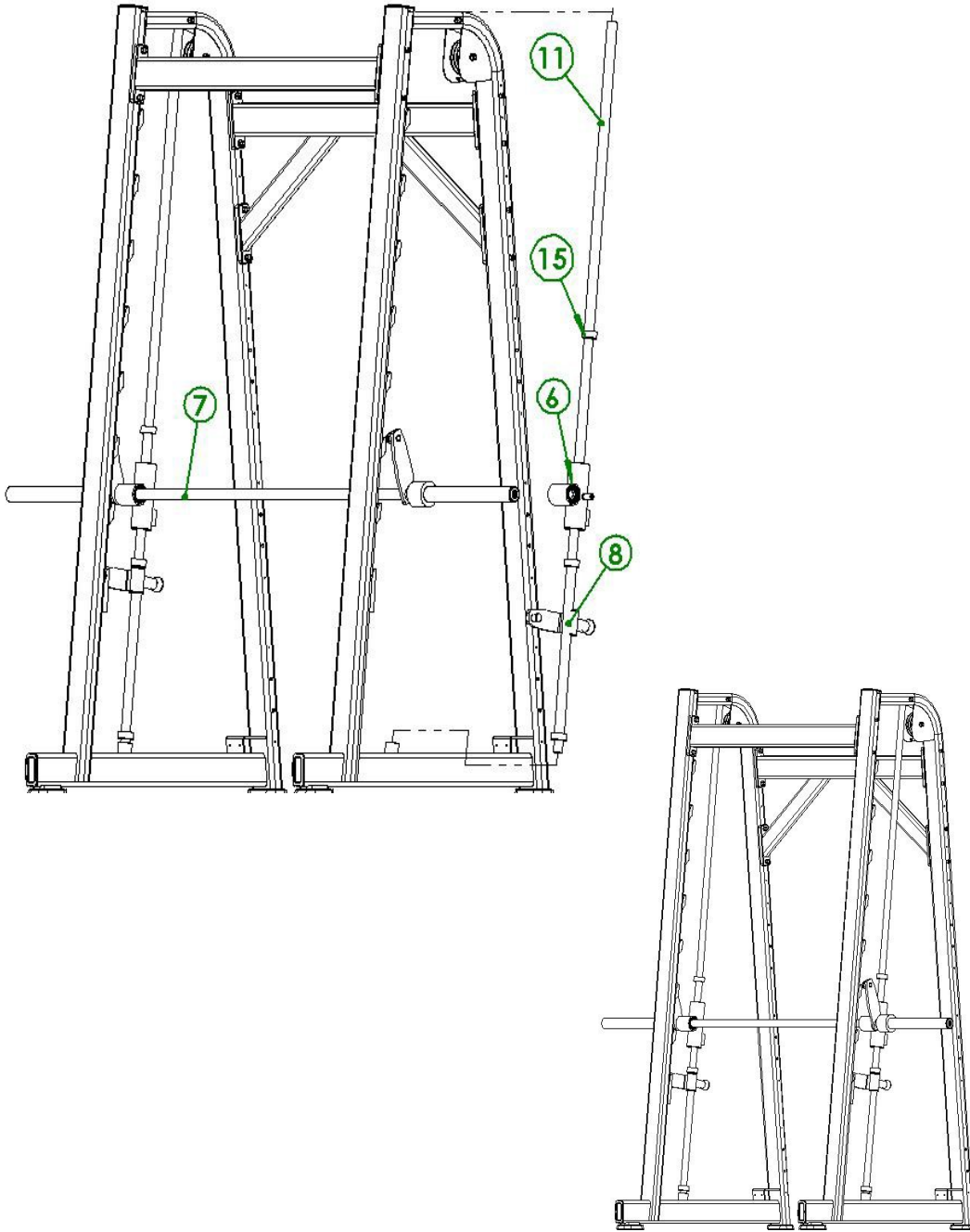

Assembly steps

Step NO	Item NO	Name	Qty	Item NO	Name	Qty
	NO. 4	Counterweight assembly	2			

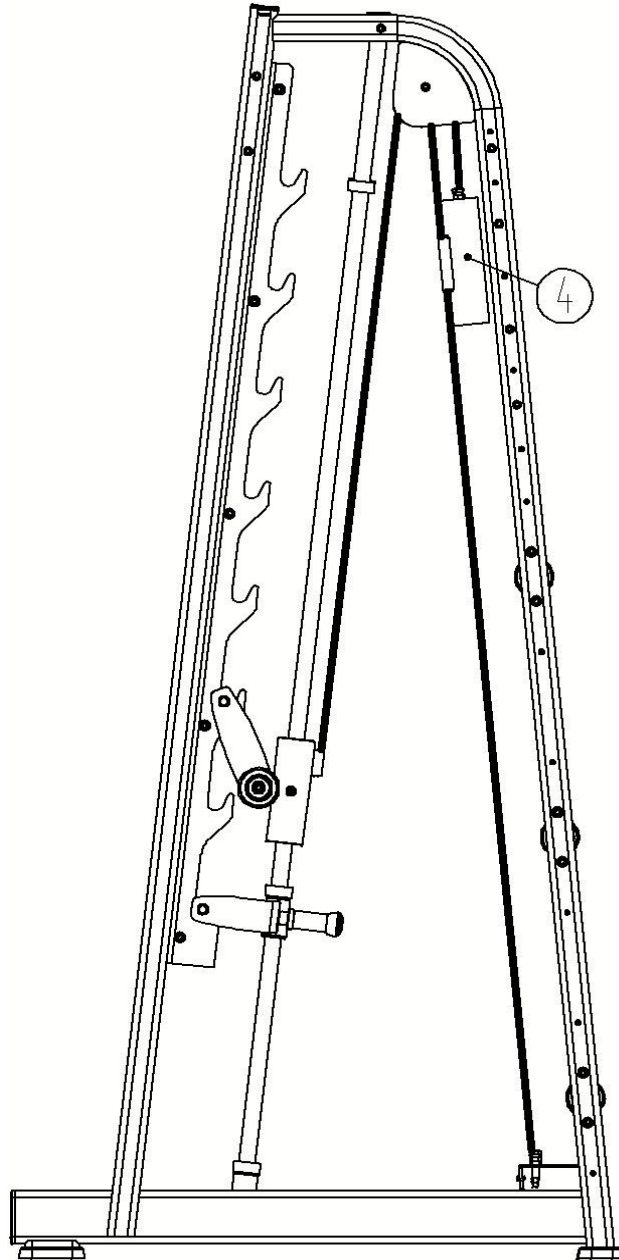

Wire rope alignment diagram

Assembly steps

Step NO	Item NO	Name	Qty	Item NO	Name	Qty
	NO. 14	Rubber Cover	2	A	M10*130Cylindrical head screws	12
	NO. 10	Guard plate-1	1	B	Φ10Gasket	12
	NO. 9	Guard plate	1	C	M10Anti-loosening nuts	12
	NO. 8	Gun barrel assembly	6	D	5*8Crossed pan round head screws	20
	NO. 16	Rubber Ring	2	E	M6*10Half round head screws	4

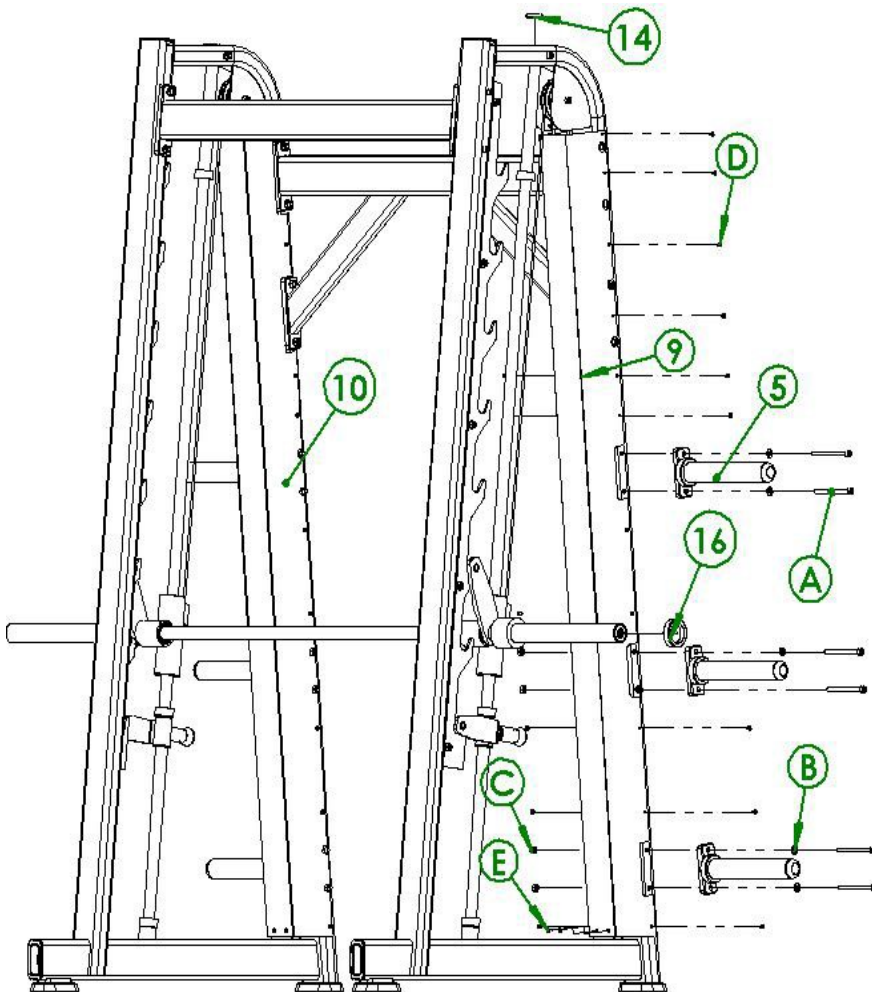

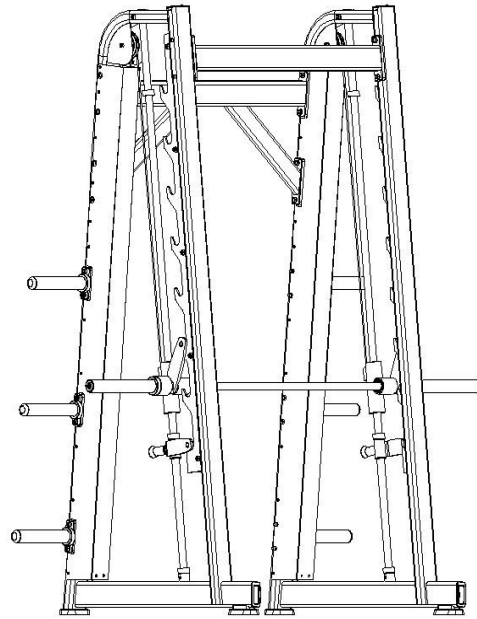

NO.4 Counterweight assembly*2 pieces

Step NO	Item NO	Name	Qty	Item NO	Name	Qty
	NO. 36	Nylon sleeve	4			

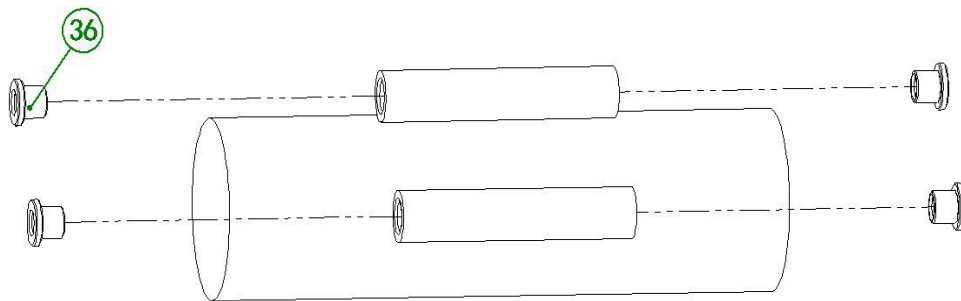

NO.5 Gun barrel subassembly*6pcs

Step NO	Item NO	Name	Qty	Item NO	Name	Qty
	NO. 16	Rubber Ring	1			
	NO. 37	tainless steel pipe plu	1			

