

FRENCH FITNESS

FFM-GD / FFN-GD

FRENCH FITNESS MARIN AND NAPA
GLUTE DRIVE (NEW)

ASSEMBLY MANUAL



FEATURES

- Paint Color: Silver/Gray
- Vinyl Color: Black
- Plate loaded
- High quality ASTM A36 steel tube
- Steel Tube Dimensions: 50mm x 80mm x 3mm
- 11 gauge steel
- Tungsten Inert Gas (TIG) welding
- Adjustable Seat and rollers
- Padded back pad
- Quality PU leather
- Electrostatic powder coating
- Comfortable & adjustable padded waist harness
- Oversized angled foot platform for various foot positions
- Integrated resistance band pegs
- Fully adjustable waist harness
- California Residents see Prop 65 WARNINGS

TECH SPECS

- Max Load Capacity: 360 lbs (up to four 45 lb Olympic plates on each side)
- Weight: 188lb (85kg)
- Dimensions:: 70"L x 64"W x 28"H (L:1780mm, W:1620mm, H:700mm)

WARRANTY

10 Years Parts, 1 Year Labor (Commercial)

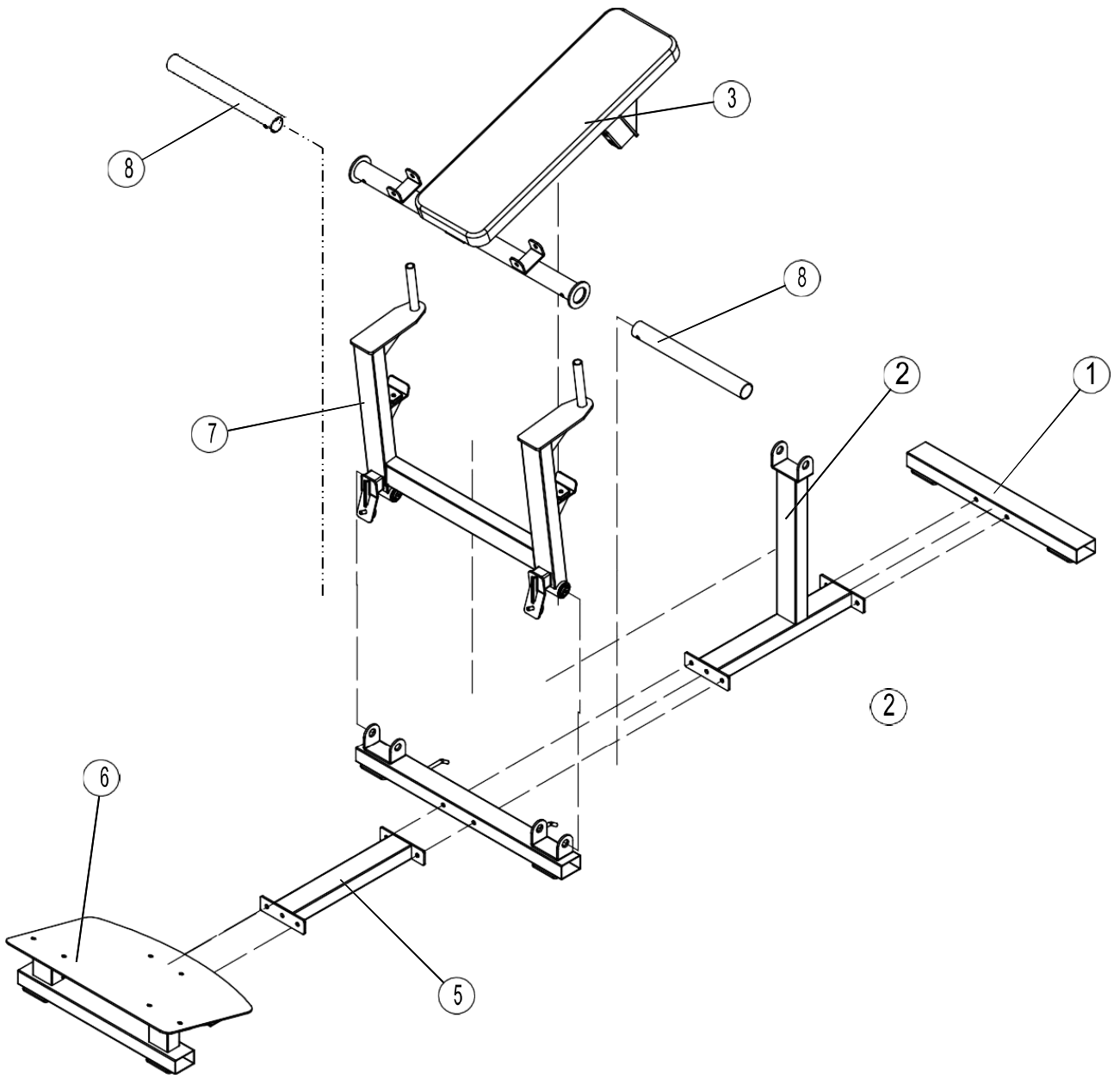

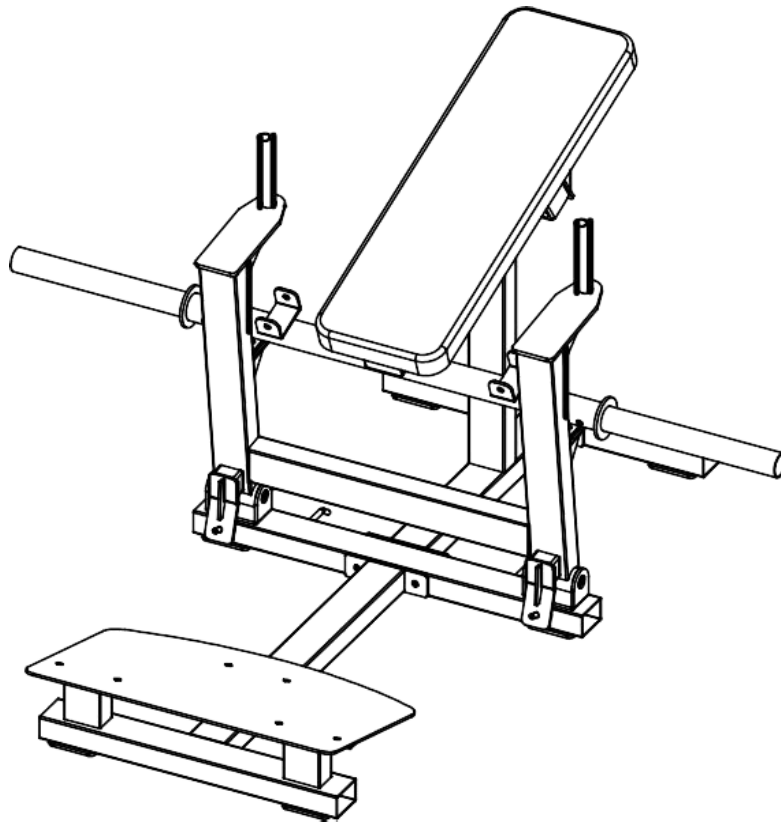

serial number	name of the accessories	number	unit
1	At the bottom of the horizontal tube	1	Piece
2	Bottom link pipe	1	Piece
3	Back cushion	1	Piece
4	Intermediate link beam	1	Piece
5	Pedal link pipe	1	Piece
6	pedal	1	Piece
7	main frame	1	Piece
8	Stainless steel barrel	2	piece