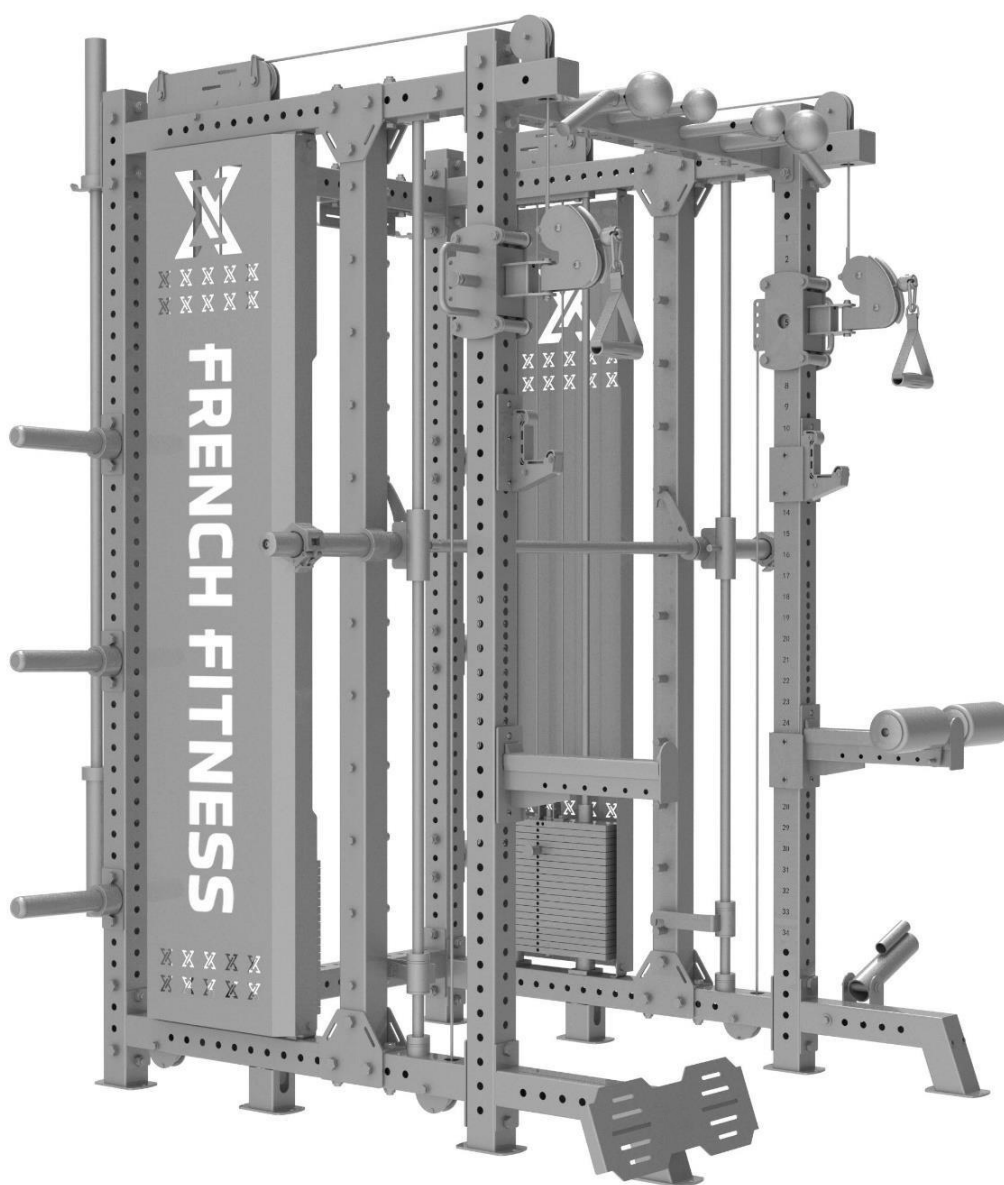


FRENCH FITNESS

FSR100

**French Fitness FSR100 Commercial
Functional Smith Rack System**

ASSEMBLY MANUAL



WARRANTY

- Lifetime Parts and 1 Year Labor Warranty

1. IMPORTANT SAFETY INSTRUCTIONS

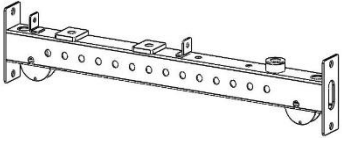
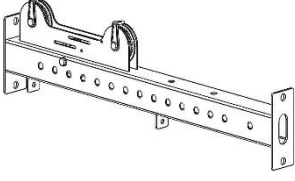
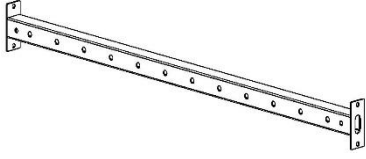

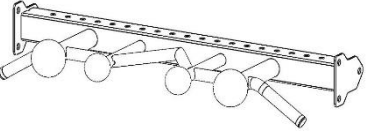
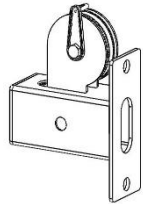
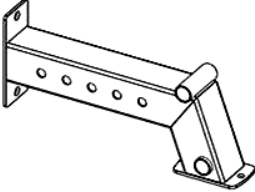
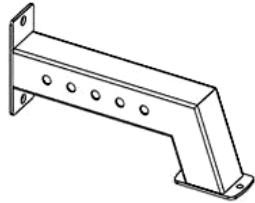

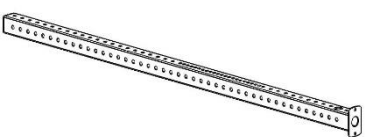
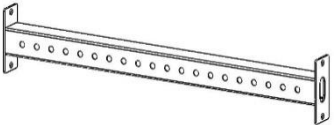
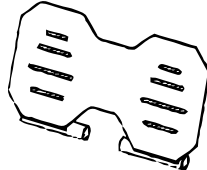
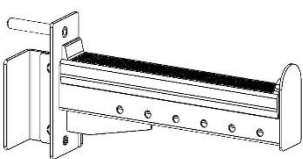
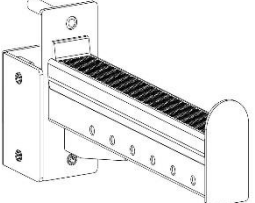
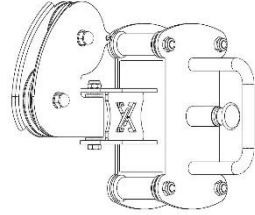
WARNING - Read all instructions before using this machine.

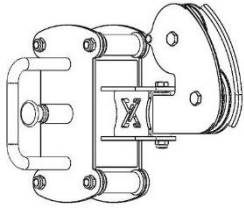
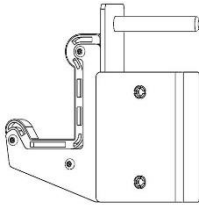
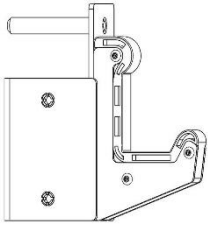
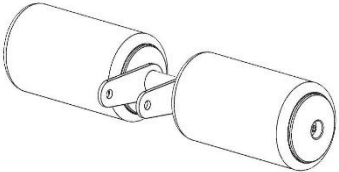
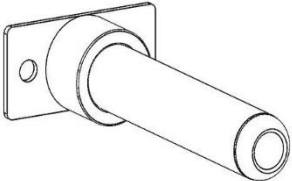
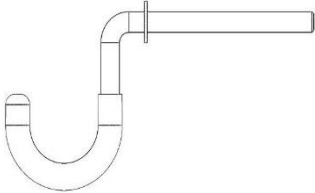
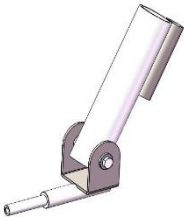
- Install the product on a flat level surface
- Place your unit on a solid, level surface when in use
- Never allow children on or near the machine.
- Keep hands away from all moving parts.
- Never drop or insert any object into any openings.
- Care must be taken when lifting or moving the equipment so as not to injure your back. Always use proper lifting techniques and/or seek assistance if necessary.
- Keep children and pets away from the machine at all times. **DO NOT** leave children unattended in the same room with the machine.
- Only 1 person at a time should use the machine.
- If the user experiences dizziness, nausea, chest pain, or any other abnormal symptoms, **STOP** the workout at once. **CONSULT A PHYSICIAN IMMEDIATELY**
- Do not use the machine near water or outdoors.
- Keep hands away from all moving parts.
- Always wear appropriate workout clothing when exercising. **DO NOT** wear robes or other clothing that could become caught in the machine. Running or aerobic shoes are also required when using the machine.
- Use the machine only for its intended use as described in this manual. **DO NOT** use attachments not recommended by the manufacturer.
- Do not place any sharp objects around the machine.
- Disabled person should not use the machine without a qualified person or physician in attendance.
- Never operate the machine if the machine is not functioning properly.
- A spotter is recommended during exercise.

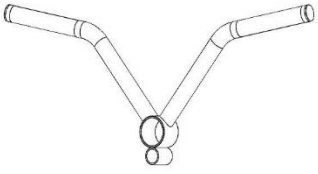
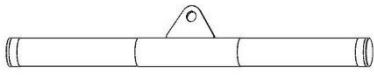
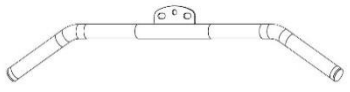

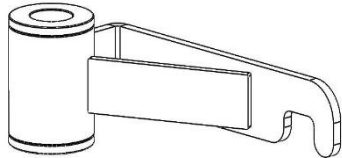
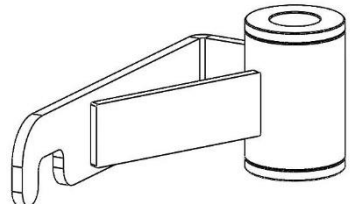
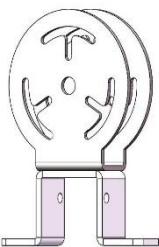
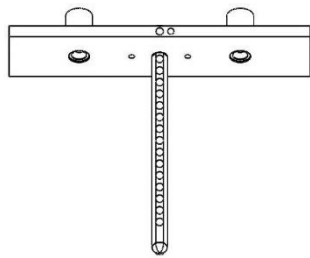
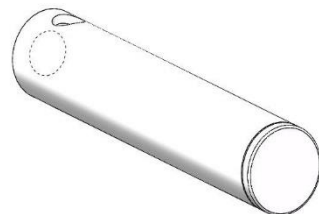
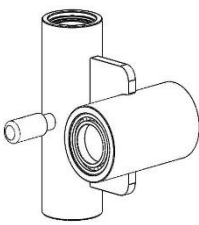
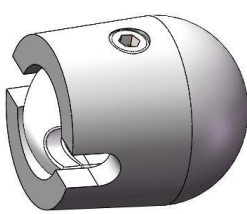
TABLE OF CONTENTS

French Fitness FSR100 Commercial Functional Smith Rack System	4
French Fitness FSR100 Adjustable Bench	41
French Fitness FSR100 Lat Pulldown Low Row Attachment	51

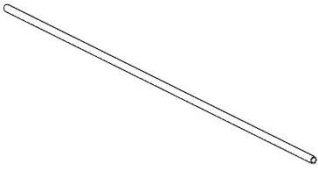
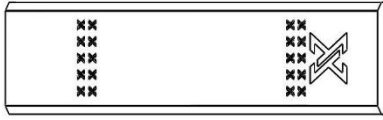

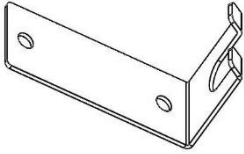
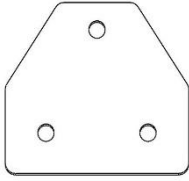
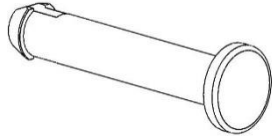
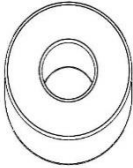
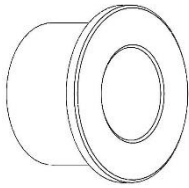
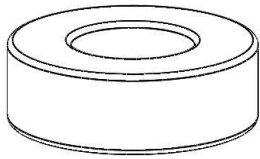
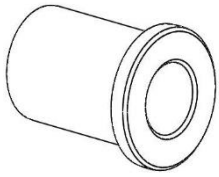


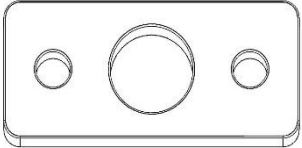
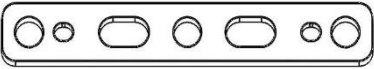
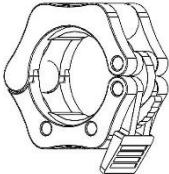
ACCESSORIES LIST 1

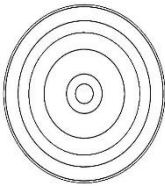
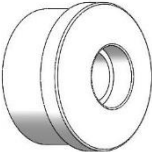



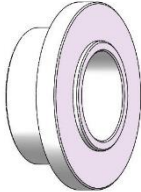
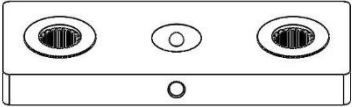
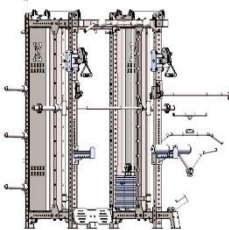
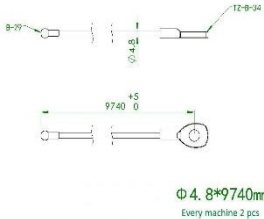


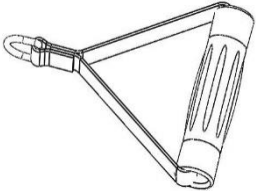
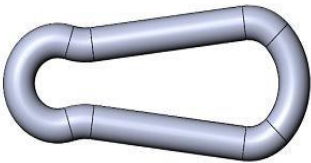
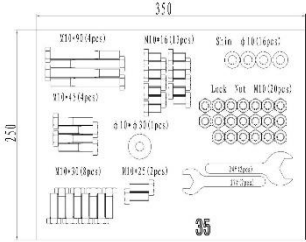

					
#1	Weight stack bottom pipe welding group * 2	#2	Weight Stack top welding group * 2	#3	Hook column stand pipe welding group * 2
					
#4	Push rod * 1	#5	Front connection welding group * 1	#6	Upper pulley set * 2
					
#7a	Front elbow welding group * 1	#7b	Front elbow welding group * 1	#8	Rear riser welding group * 2
					
#9	Front column welding group * 2	#10	Lower connection welding group * 2	#11	Foot welding group * 1
					
#12	Left fuse set * 1	#13	Right fuse set * 1	#14	Sliding sleeve welding set left * 1

					
#15	Sliding sleeve welding set right *1	#16	Hook welding group left *1	#17	Hook welding group right *1
					
#18	Press leg welding set *1	#19	Hanging rod welding group * 6	#20	Hook welding set * 4
					
#21	Bottom weight holder *1				

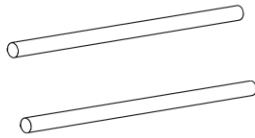
					
#22	Lifting welding group *1	#23	Low-stretch welding group *1	#24	High-stretch welding group *1
					
#25	Push rod welding group *1	#26	Smith Insurance Group Left*1	#27	Smith Insurance Group Right*1
					
#28	Small door pulley set * 2	#29	Weight Stack Group * 2	#30	Hook column assembly * 24
					
#31	Optical shaft sleeve welding set * 2	#32	Wire rope joint * 2		

ACCESSORIES LIST 2

					
#34	Φ20*2*1975mm small door guide rod*4	#35	1885mm*627 large guard plate*2	#36	Φ25*1958mm Smith optical axis*2
					
#37	Olympic Bar lock plate * 2	#38	Decorative board 2*8	#39	Card rope pin * 10
					
#40	Weight sheet rubber pad * 4	#41	Pulley limit sleeve * 8	#42	Round shock cushion * 4
					
#43	Pulley spacer * 12	#44	T-type bolt * 1	#45	Olympic Bar 2.2m*1
					
#46	Optical axis fixing seat * 2	#47	Optical axis fixing plate * 2	#48	Barbell card set * 2



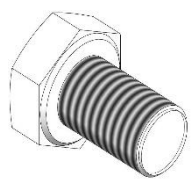
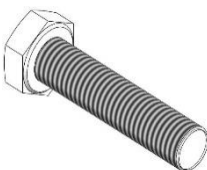
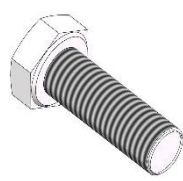
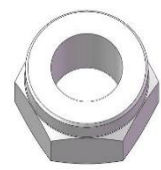
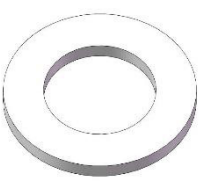
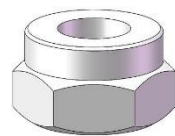

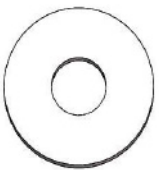
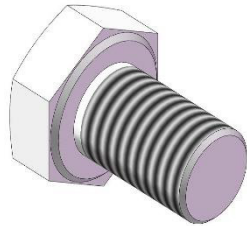
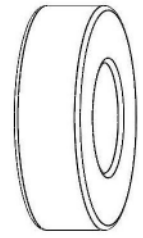
					
#49	Φ90 pulley*6	#50	Nylon end cap * 2	#51	Φ50*320 stainless steel pipe*2
					
#52	Thick rubber sleeve*2	#53	Spacer * 2 (320lb VERSION ONLY)	#54	Nylon sleeve*2
				 Φ 4. 8*9740mm Every machine 2 pcs	
#55	Weight Stack *38pieces	#90	Manual *1piece	#91	Cable *2 pieces
					
#92	Weight Stack plug*2	#93	Chain 10 sections * 2	#94	Low pull handle*2
					
#95	Standard safety hook*6	#96	Blister pack*1	#97	Biceps pressing rope*1

22LB ● 10KG
33LB ● 15KG
44LB ● 20KG
55LB ● 25KG
66LB ● 30KG
77LB ● 35KG
88LB ● 40KG
99LB ● 45KG
110LB ● 50KG
121LB ● 55KG
132LB ● 60KG
143LB ● 65KG
154LB ● 70KG
165LB ● 75KG
176LB ● 80KG
187LB ● 85KG
198LB ● 90KG
209LB ● 95KG
220LB ● 100KG



#98	weight stack sticker *2	J	φ25x430L fixed shaft		
-----	-------------------------	---	----------------------	--	--

Blister Pack Screw List-3

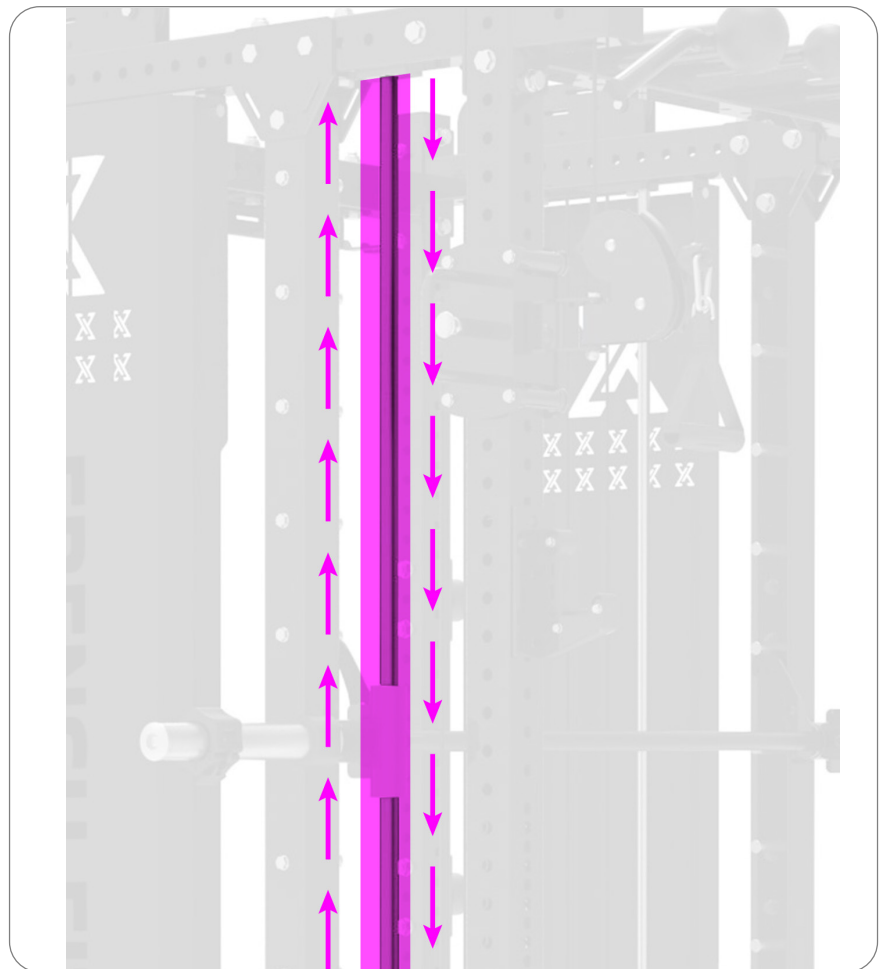
					
A	16*100 Outer Hexagon Screws*62pcs	B	10*90 Outer Hexagon Screws*4pcs	C	10*16 Hexagonal Screws*13pcs
					
D	10*45 Outer Hexagon Screw*4pcs	E	10*30 external hexagonal screws*8pcs	F	M16 lock nuts*62pcs
					
G	Φ16 gasket*62pcs	H	M10 lock nut*18pcs	I	Φ10 gaskets*14pcs
					
W	Small hole big cushion * 1 piece	X	M10*25 hex screws *2pcs	#100	Spacer (320lb VERSION ONLY)

Step must be completed prior to installing. Failure to do so can leave residue from packaging and other sources stuck in the bushings.

Guide rods need to make sure they are cleaned prior to installation otherwise this will cause the top plate to get stuck. It causes buildup in the bushings of the top plates. They just need to be cleaned out as well as the guide rods.

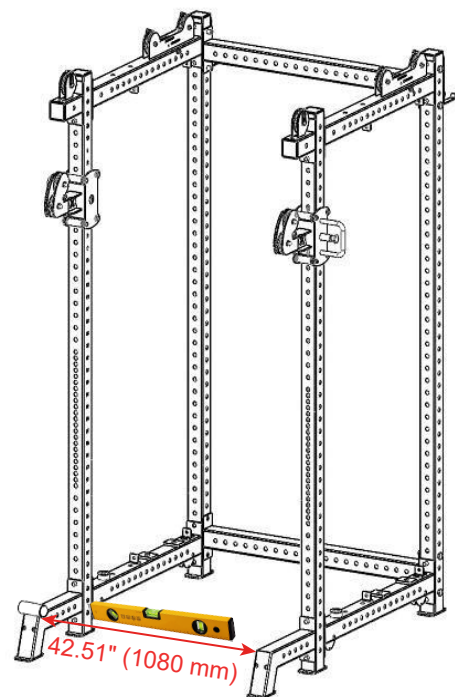
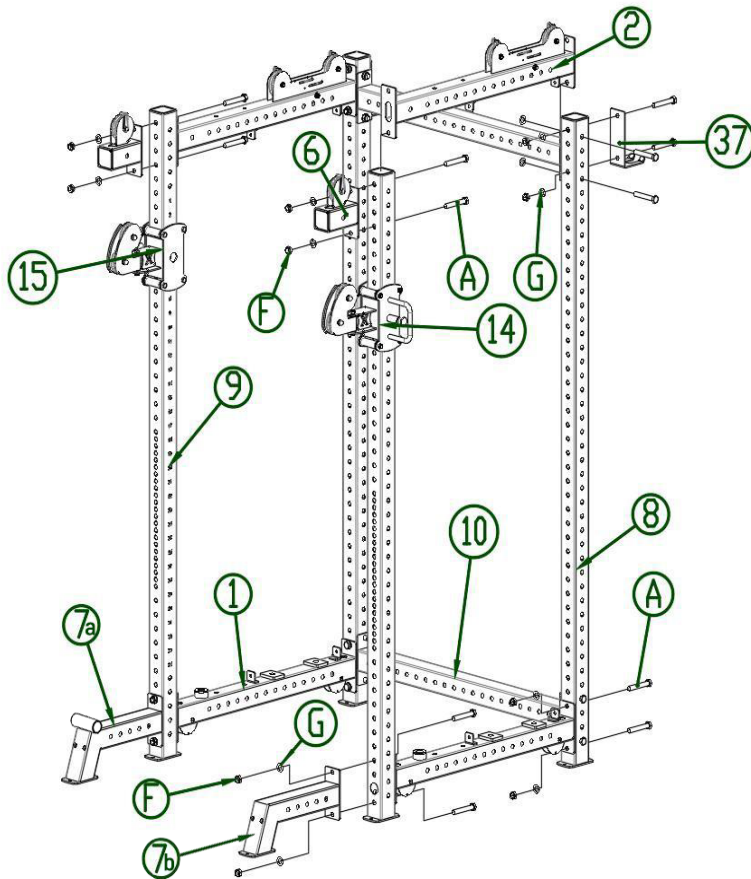
Use Silicon Spray and fiber to remove any excess residue. These can be found around the house or at a nearby hardware store, pics below. Use silicon Spray and steel wool.

We use "B'laster 16-SL Industrial Strength Silicone Lubricant" and Steel Wool, Grade #0000 Super Fine Grade.



ASSEMBLY STEPS

Step NO	Item NO	Name	Qty	Item NO	Name	Qty
1	NO 1	Counterweight bottom pipe welding group	2	NO 37	Olympic bar lock plate	
	NO 2	Counterweight top welding group	2	NO 10	Lower connection components	2
	NO 6	Upper support pulley welding group	2	NO 14	Cable crossover combination right	1
	NO 7a	Front elbow welding group	1	NO 15	Cable crossover combination left	1
	NO 7b	Front elbow welding group	1	A	M16*100 Hexagon screw	24
	NO 8	Behind column welding group	2	G	Ø16 Gasket	24
	NO 9	Front column welding group	2	F	M16 Locknut	24

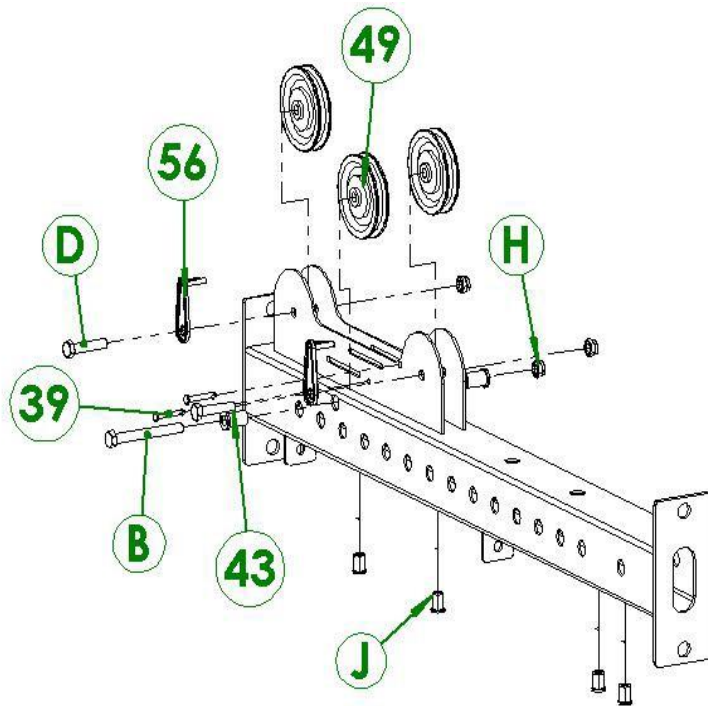


Install pulleys on all metal frame parts prior to attaching all parts together

If you tighten every bolt firmly at first, it may result in the distortion of the finished product. To avoid this, tighten bolts lightly until the main frame is assembled and leveled then fasten the all bolts firmly. Be sure the distance between the frame - as shown in the pic below - is 42.51. Also, input a leveler in the exact spot as the pic shows to be sure it is level

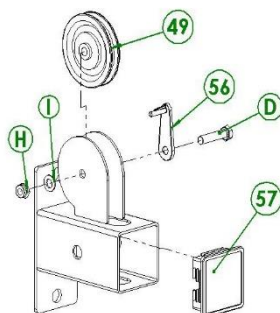
No.2 Counterweight top welding group * 2

Step NO	Item NO	Name	Qty	Item NO	Name	Qty
	NO 56	Pulley card rope sleeve	2	D	M10*45 Hexagon screw	2
	NO 49	Φ90 pulley	3	B	M10*90 Hexagon screw	1
	NO 43	Pulley spacer	2	J	M10 Pull riveting	4
	NO 39	Clamp pin	2	H	M10 Locknut	3



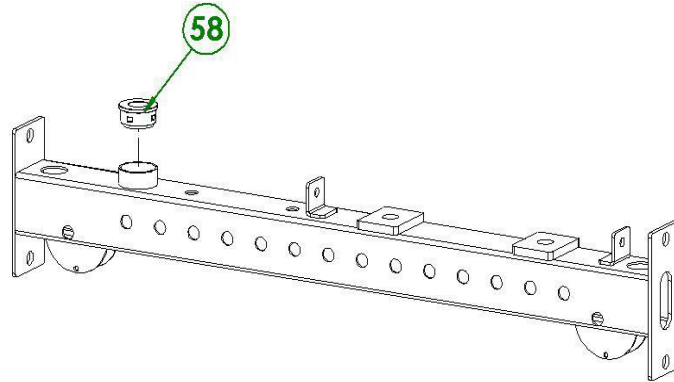
No.6 Upper support pulley welding group * 2

Step NO	Item NO	Name	Qty	Item NO	Name	Qty
	NO 49	Φ90 pulley	1	H	M10 Locknut	1
	NO 50	Pulley card rope sleeve	1	D	M10*45 Hexagon screw	1
	NO 57	75*75 Square pipe plug	1	I	Ø10 Gasket	1



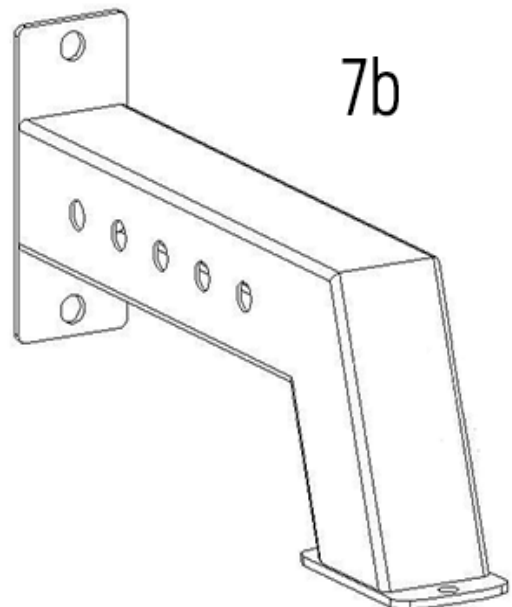
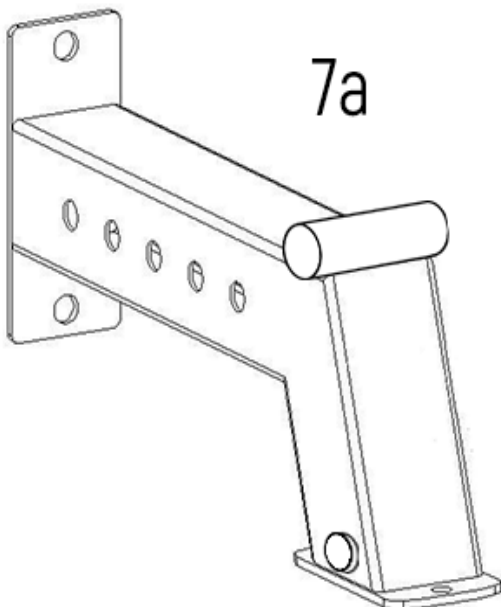
No.1 counterweight bottom pipe welding set * 2

Step NO	Item NO	Name	Qty	Item NO	Name	Qty
	NO 58	Bottom nylon sleeve	1			



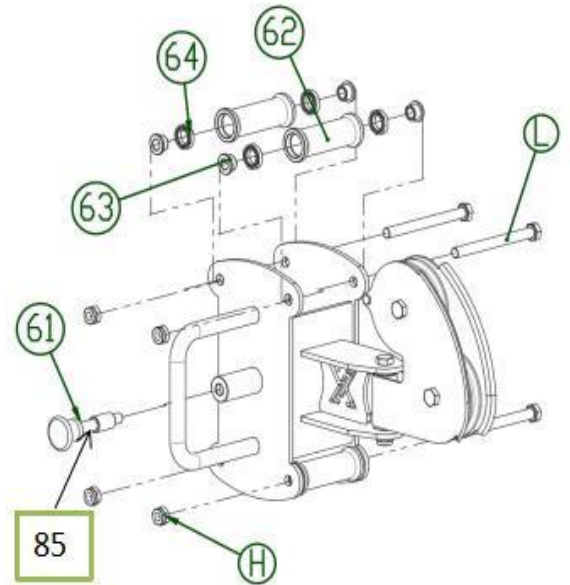
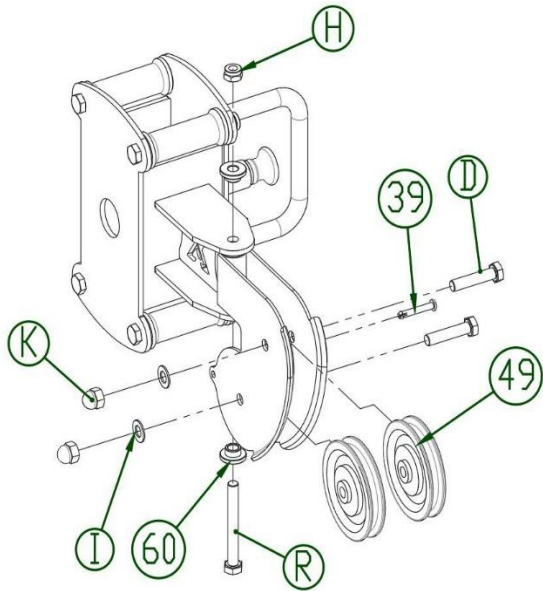
No.7a / 7b Front elbow welding group * 2

Step NO	Item NO	Name	Qty	Item NO	Name	Qty



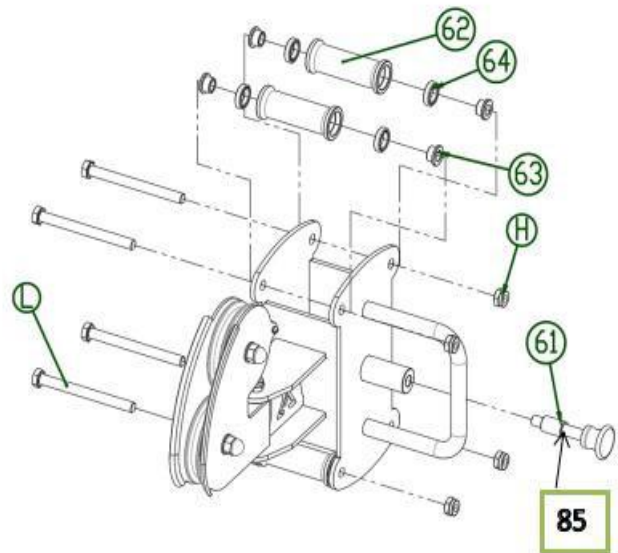
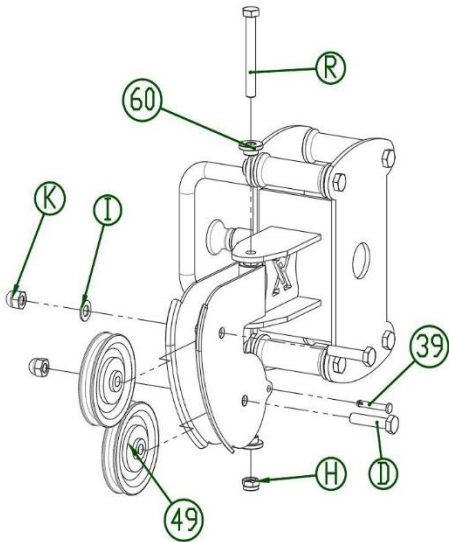
No.14 Cable crossover pulley right*1

Step NO	Item NO	Name	Qty	Item NO	Name	Qty
	NO 49	Φ90 Pulley	2	NO 64	61802 Bearing	8
	NO 30	Clamp pin	1	H	M10 Locknut	5
	NO 60	Cable crossover Nylon sleeve	2	D	M10*45 Hexagon screw	2
	NO 61	Aluminum alloy bolt	1	K	M10 Nut	2
	NO 62	Sliding roller	4	I	Φ10 Gasket	2
	NO 63	Roller spacer	4	R	M10*80 Hexagon screw	1
	NO 85	spring	1	L	M10*110 Hexagon screw	4



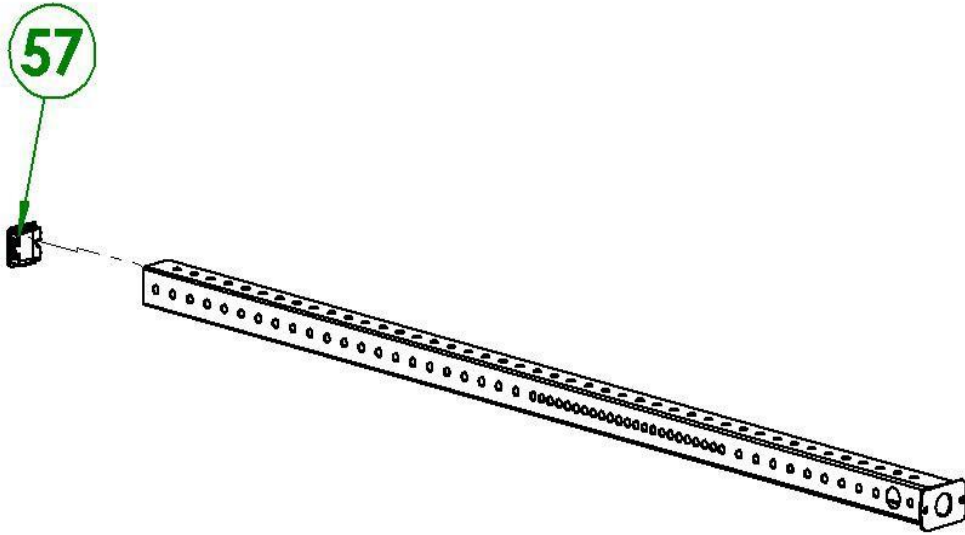
No.15 Cable crossover pulley left *1

Step NO	Item NO	Name	Qty	Item NO	Name	Qty
	NO 49	Φ90 Pulley	2	NO 64	61802 Bearing	8
	NO 39	Clamp pin	1	H	M10 Locknut	5
	NO 60	Cable crossover Nylon sleeve	2	D	M10*45 Hexagon screw	2
	NO 61	Aluminum alloy bolt	1	K	M10 Nut	2
	NO 62	Sliding roller	4	I	Φ10 Gasket	2
	NO 63	Roller spacer	4	R	M10*80 Hexagon screw	1
	NO 85	spring	1	L	M10*110 Hexagon screw	4



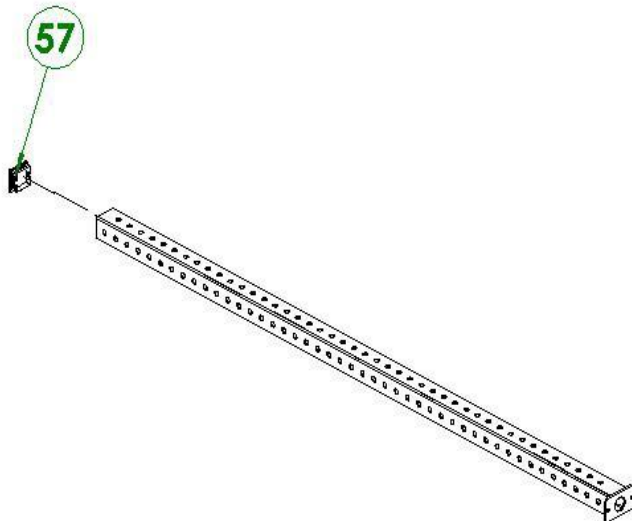
No.9 Front pillar welding group * 2 pcs

Step NO	Item NO	Name	Qty	Item NO	Name	Qty
	NO 57	75*75 Square pipe plug	1			



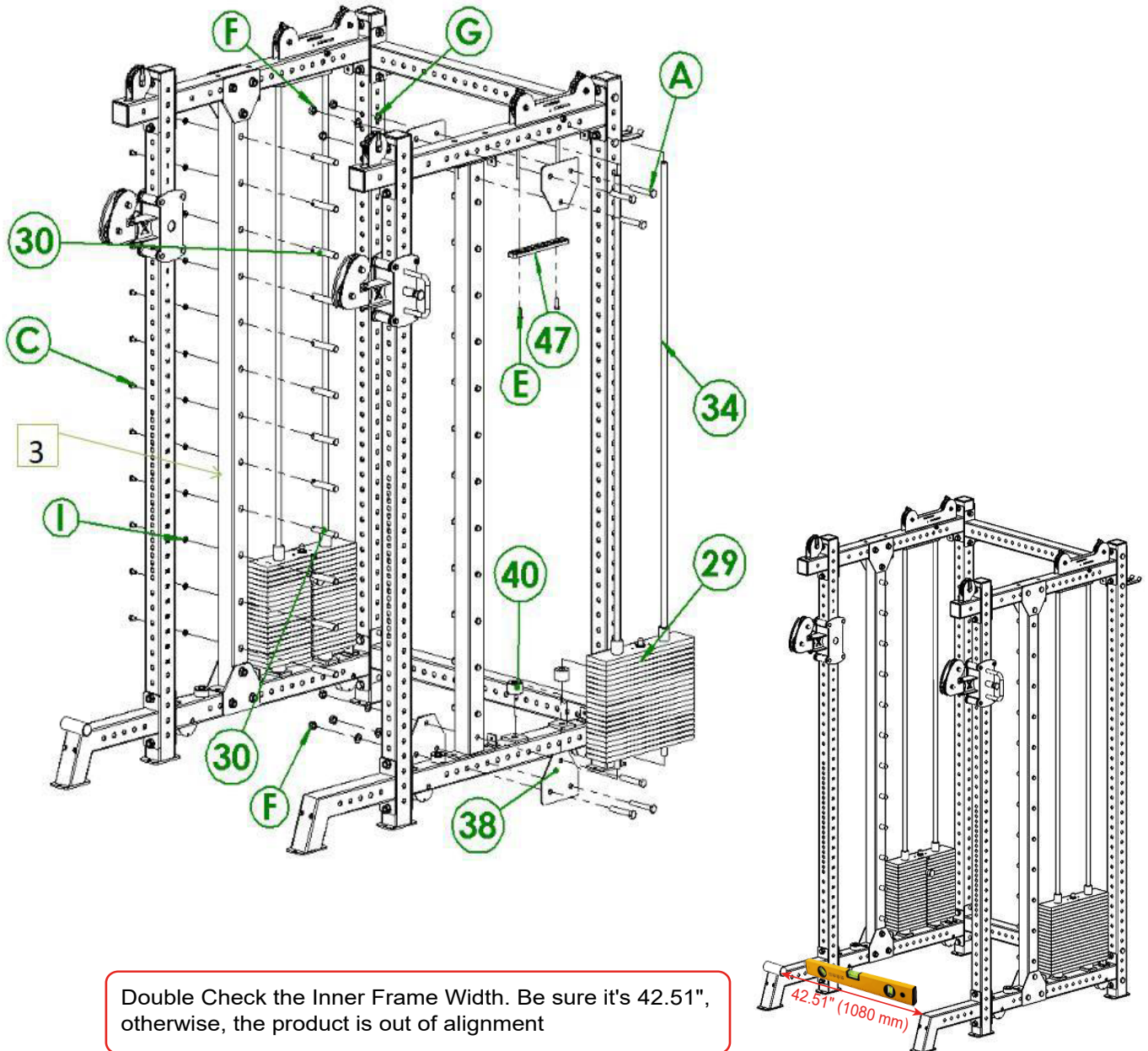
No.8 Behind riser welding group * 2

Step NO	Item NO	Name	Qty	Item NO	Name	Qty
	NO 57	75*75 Square pipe plug	1			



ASSEMBLY STEPS

Step NO	Item NO	Name	Qty	Item NO	Name	Qty
2	No.29	Weight plate combination	2	I	Φ10 Gasket	24
	No.30	Hook post	24	C	M10*16 Outer hexagon screw	24
	No.47	Optical axis mount	2	E	M10*30 Outer hexagon screw	4
	No.34	Small cover rod	4	F	M16 Locknut	12
	No.38	Decorative board 2	8	G	Φ16 Gasket	12
	No.40	Weight plate rubber mat	4	A	M16*100 Outer hexagon screw	12
	No.3	Hook stand pipe welding group	2			



Double Check the Inner Frame Width. Be sure it's 42.51", otherwise, the product is out of alignment

WARNING

Please DO NOT proceed with assembly if the floor is not level or the frame doesn't measure as described on page 16.

If the inner frame width does not measure 42.51" +/- 1/8" (as shown in the picture on page 16), please loosen frame bolts and push or pull the frame.

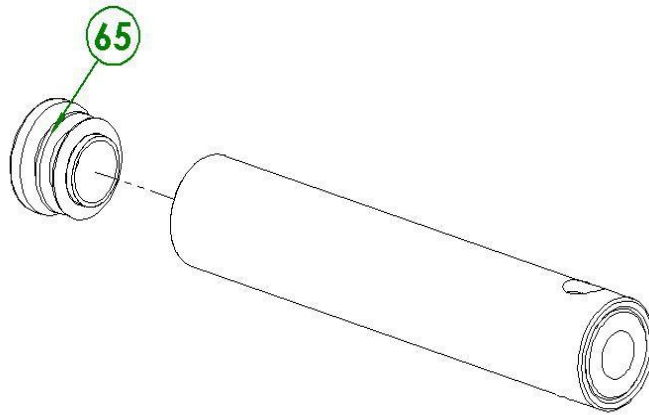
If the floor is not level (as shown in the picture on page 16), then the options are:

- placement elsewhere
- turning the machine at a different angle
- raising the proper area on the floor so the feet sit level with the rest if the feet (use a leveler on the smith bar in this case)

**FAILURE TO DO THIS WILL RESULT IN DISTORTION
OF THE SMITH MACHINE CAUSING IT
TO NOT GLIDE PROPERLY**

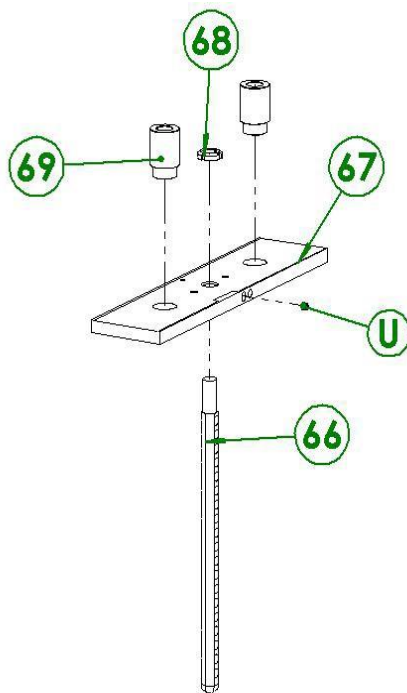
No.30 Hook post assembly*24

Step NO	Item NO	Name	Qty	Item NO	Name	Qty
	No.65	Φ20 Round pipe plug	1			



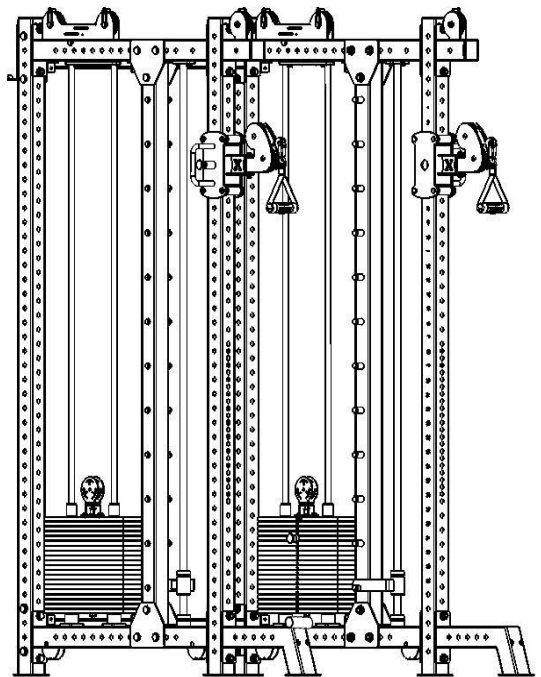
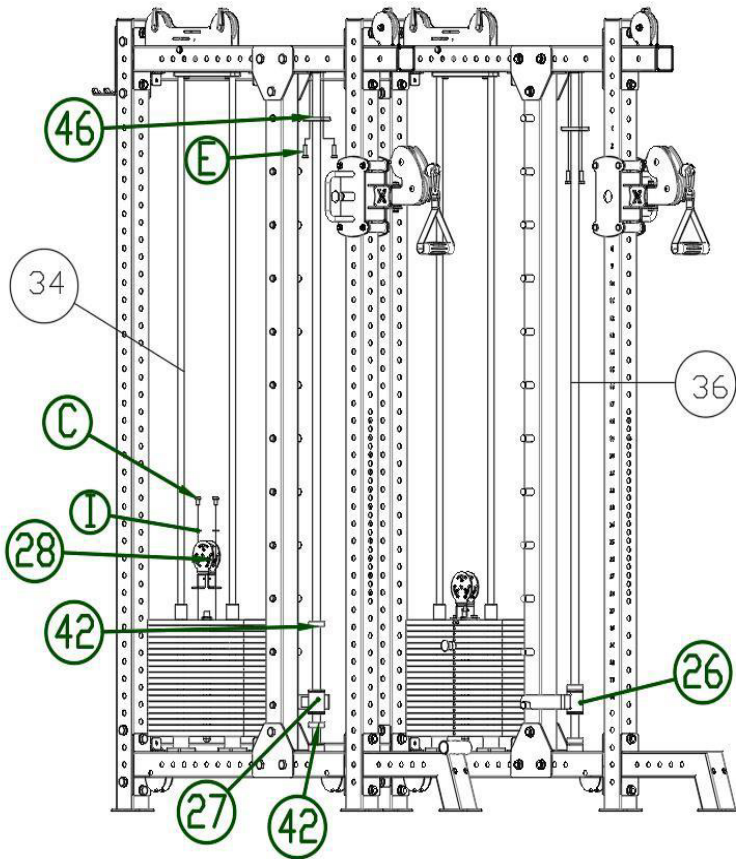
No.29 Weight plate combination*2

Step NO	Item NO	Name	Qty	Item NO	Name	Qty
	No.68	Fasten the screw nut	1			
	No.69	090 Weight plate guide sleeve	2			
	No.66	Center rod (19 hole)	1			
	No.67	First piece long weight plate	1			
	U	M10*20 Jackscrew	1			



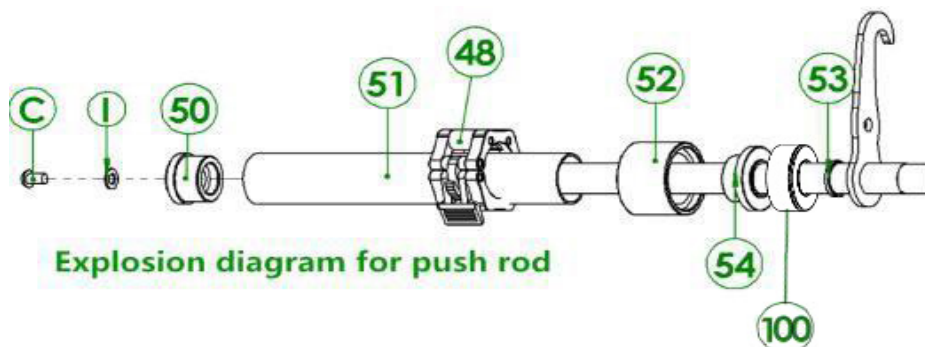
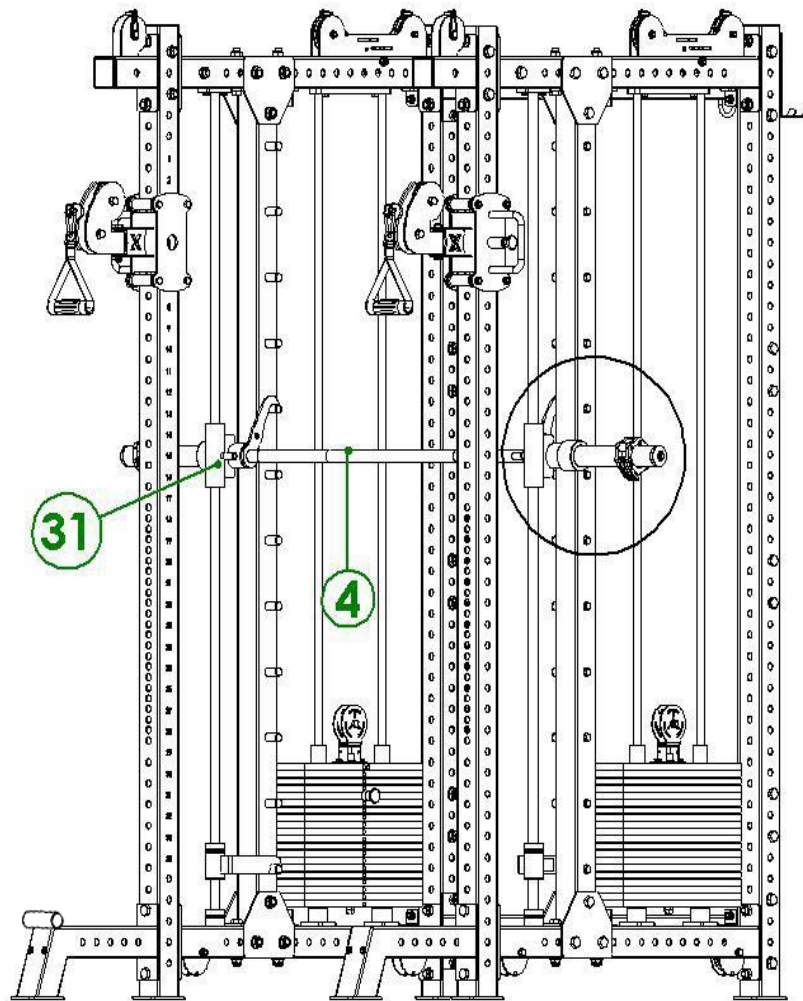
ASSEMBLY STEPS

Step NO	Item NO	Name	Qty	Item NO	Name	Qty
3	No.46	Optical axis mount	2	No.26	Smith insurance group left	1
	No.42	Round shock cushion	4	C	M10*16 Outer hexagon screw	4
	No.27	Smith insurance group right	1	I	Ø10 Gasket	4
	No.28	Small cover pulley	2	E	M10*30 Outer hexagon screw	4
	No.34	Small cover rod	4	No.36	Smith optical xis	2



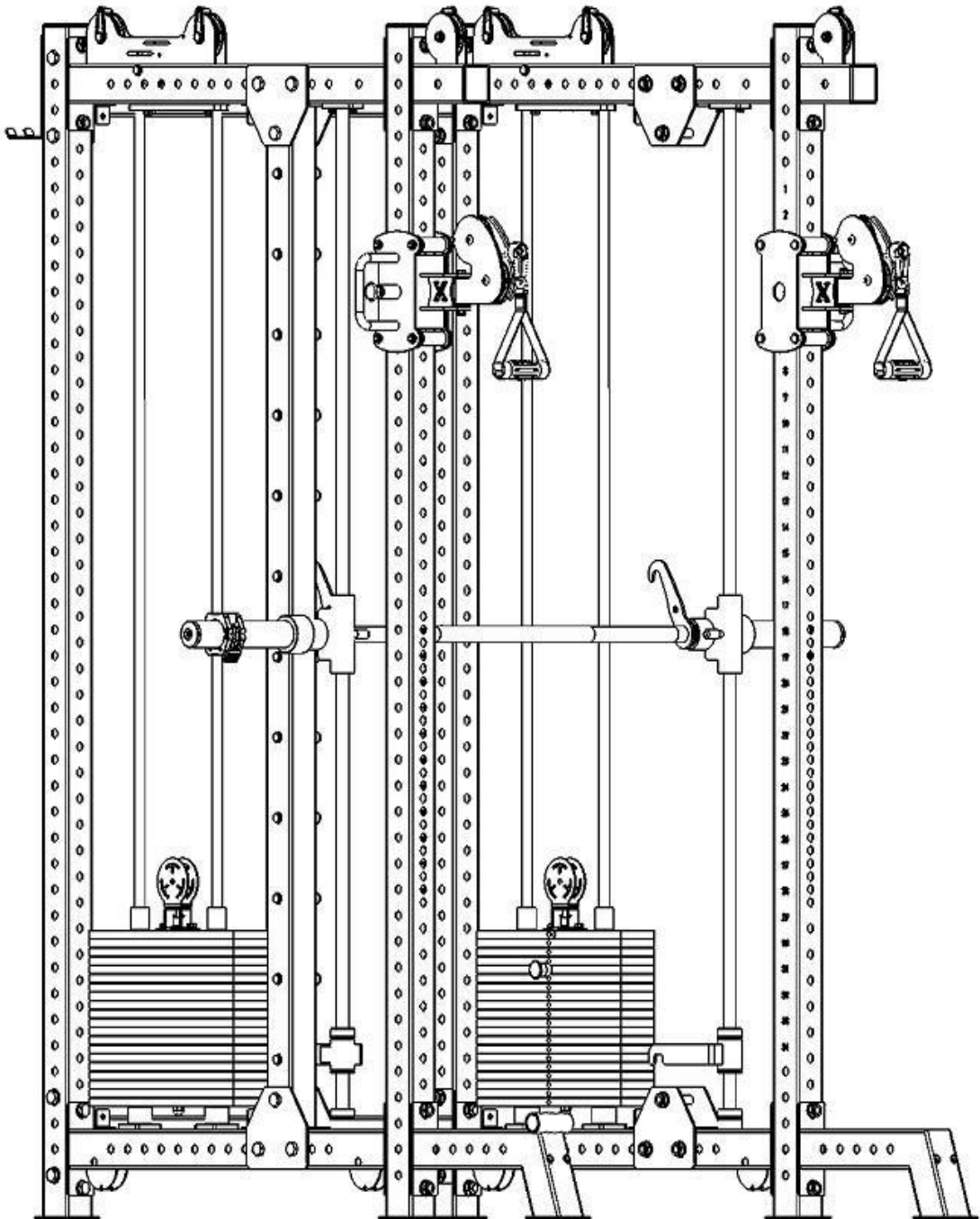
ASSEMBLY STEPS

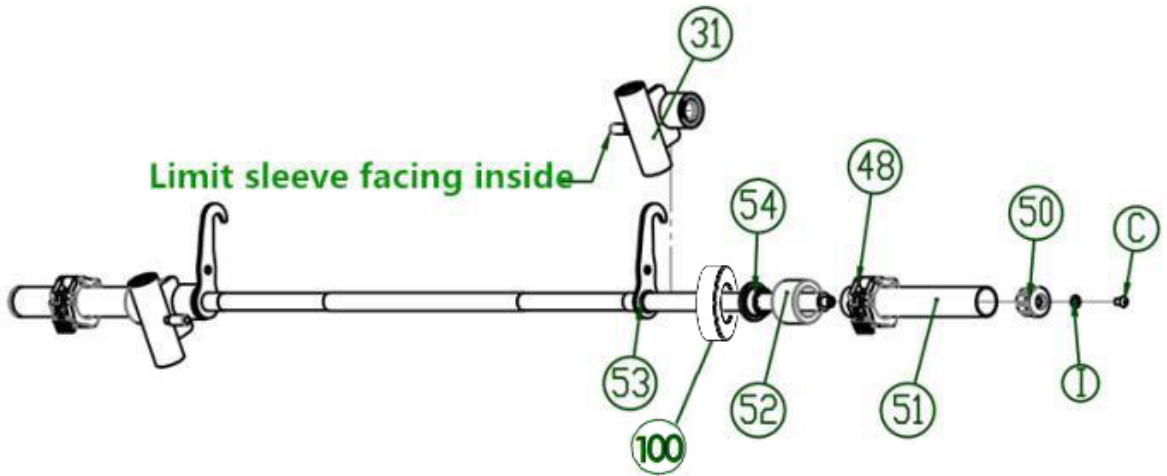
Step NO	Item NO	Name	Qty	Item NO	Name	Qty
4	No.4	Push rod combination	1	No.53	Spacer	2
	No.31	Optical shaft sleeve welding group	2	No.54	Nylon sleeve	2
	No.52	Thick rubber sleeve	2	No.48	Barbell lock jaw collar	2
	No.50	End cap	2	C	M10*16 Outer hexagon screw	2
	No.51	Stainless steel pipe	2	I	Ø10 Gasket	2
					No.100	Spacer (320lb VERSION ONLY)



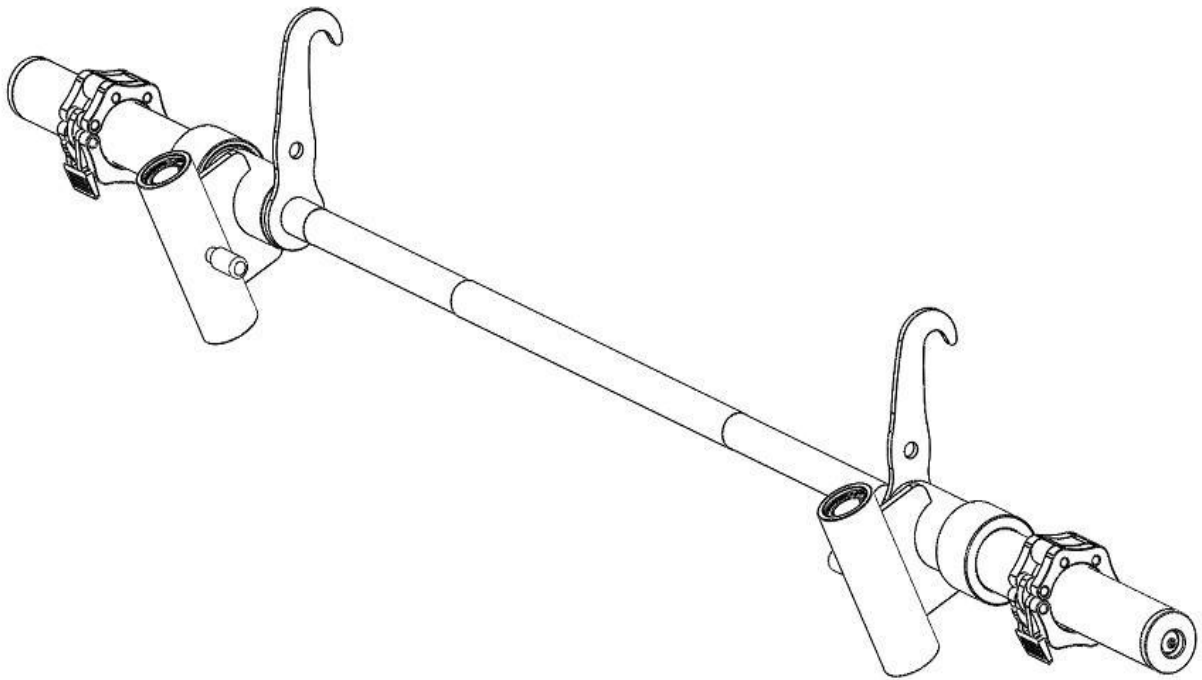
No.4 Push rod combination *1pc

Step NO	Item NO	Name	Qty	Item NO	Name	Qty
	No. 31	Optical shaft sleeve welding group	2	No.50	End cap	2
	No.53	Spacer (320lb VERSION ONLY)	2	No.54	Nylon sleeve	2
	No.52	Thick rubber sleeve	2	I	Ø10 Gasket	2
	No.51	Stainless steel pipe	2	C	M10*16 Outer hexagon screw	2
	No.48	Barbell lock jaw collar	2			



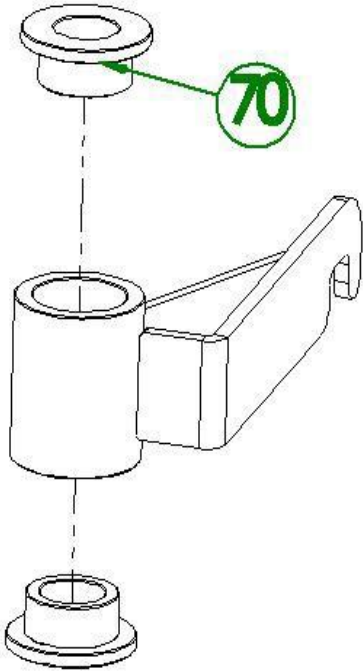


320 lb VERSION ONLY



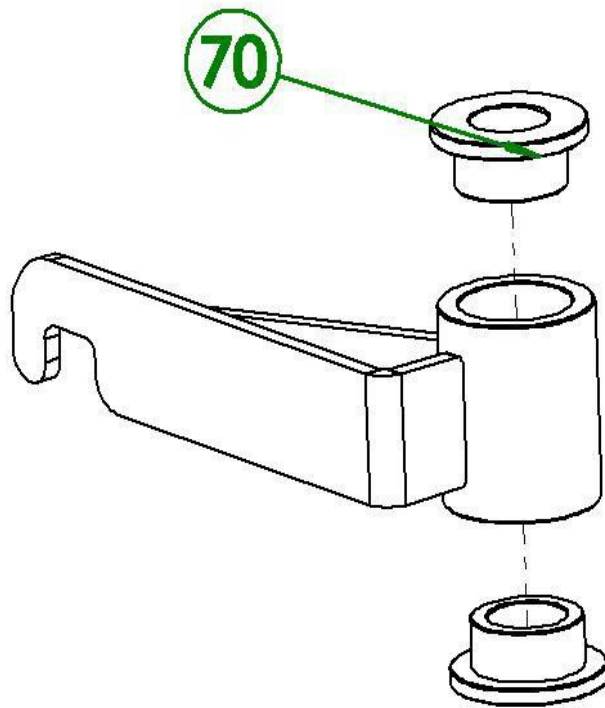
SMITH INSURANCE GROUP RIGHT* 1

Step NO	Item NO	Name	Qty	Item NO	Name	Qty
	NO 70	Protection guide sleeve	2			



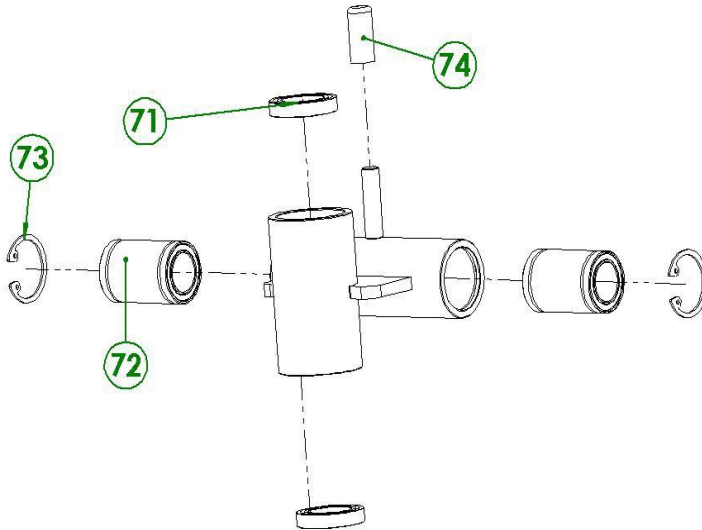
NO.26 Left Smith Insurance Group *1

Step NO	Item NO	Name	Qty	Item NO	Name	Qty
	NO 70	Protection guide sleeve	2			



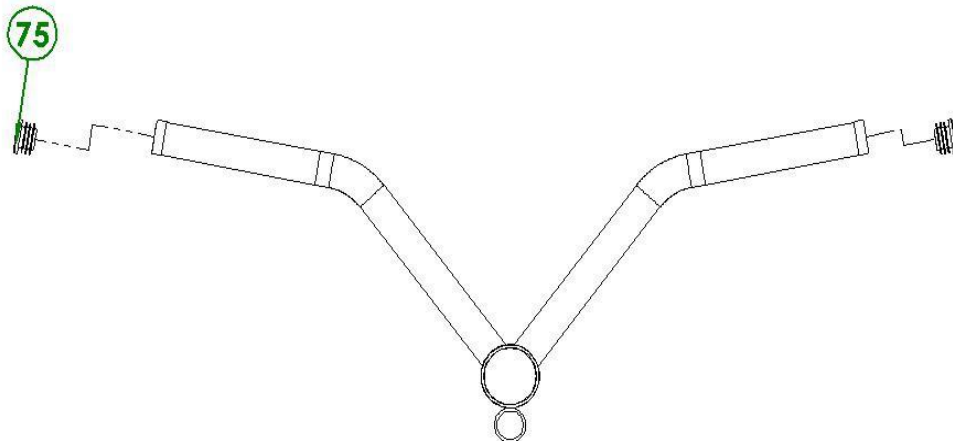
No 31 Optical shaft sleeve welding group*2

Step NO	Item NO	Name	Qty	Item NO	Name	Qty
	NO 71	61906 bearing	2			
	NO 72	Linear bearing	2			
	NO 73	Ø40Circlip for hole	2			
	NO 74	Stop collar	1			



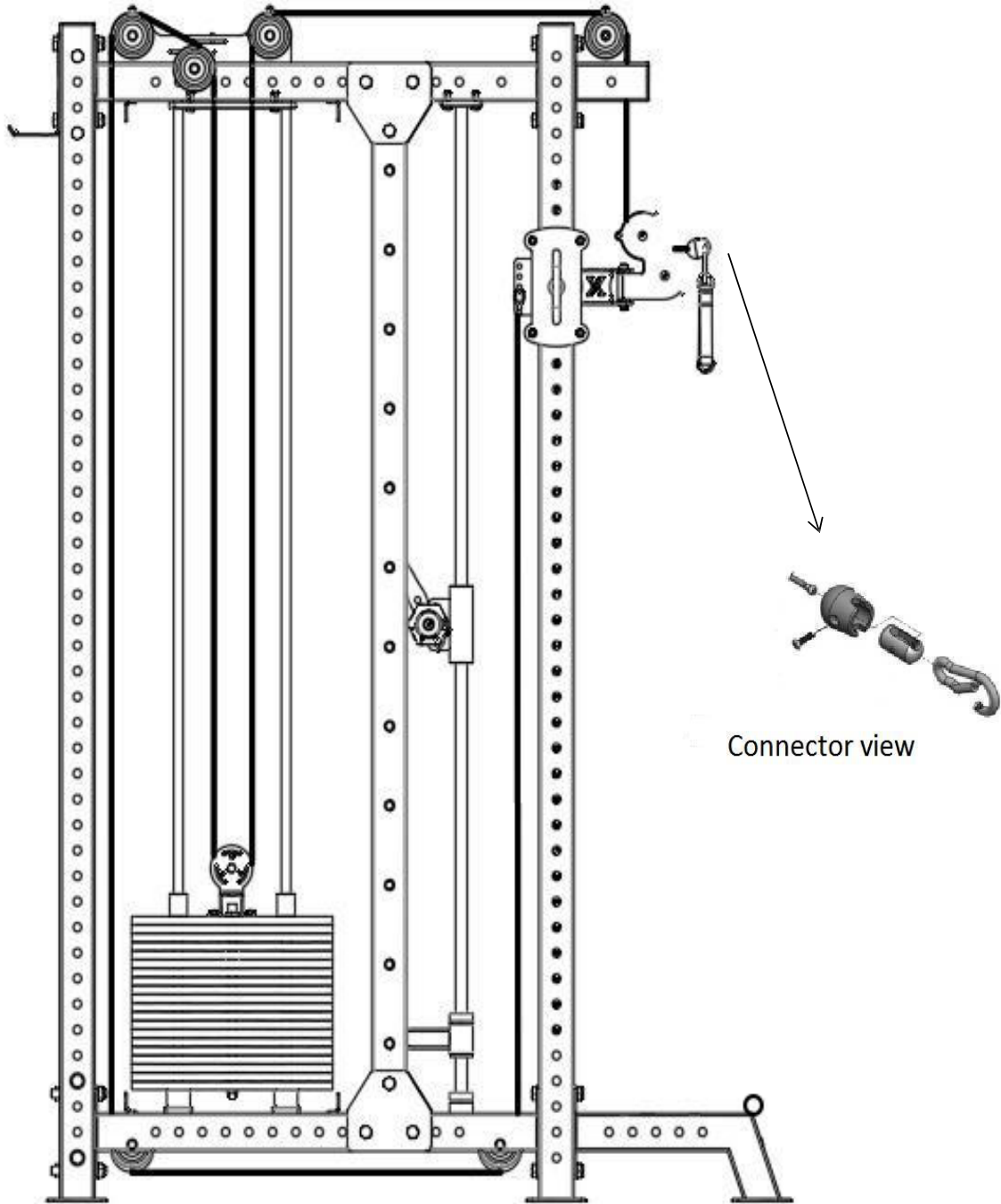
No 22 Lifting welding group * 1

Step NO	Item NO	Name	Qty	Item NO	Name	Qty
	NO 75	Φ32 Round pipe plug	2			



ASSEMBLY STEPS

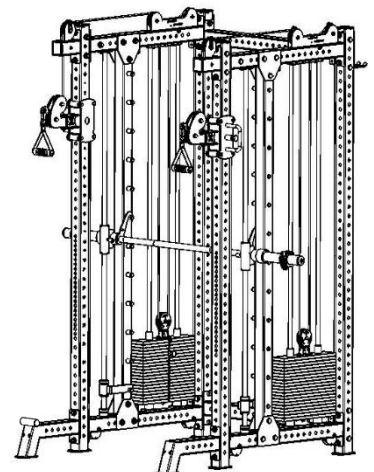
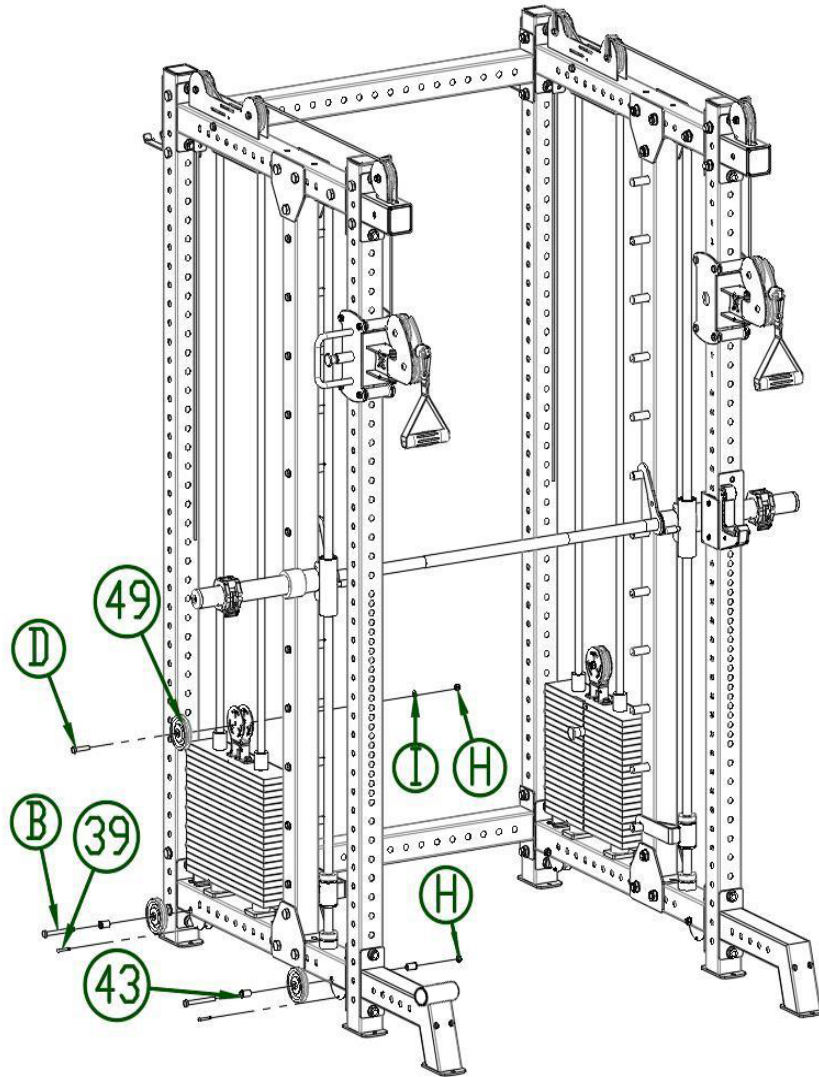
Step NO	Item NO	Name	Qty	Item NO	Name	Qty
5						



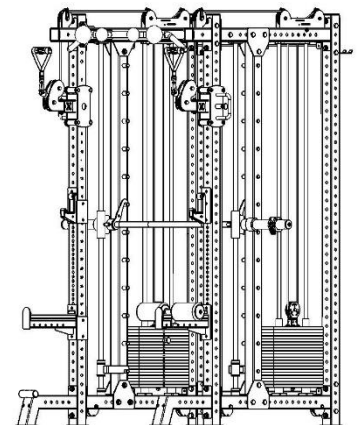
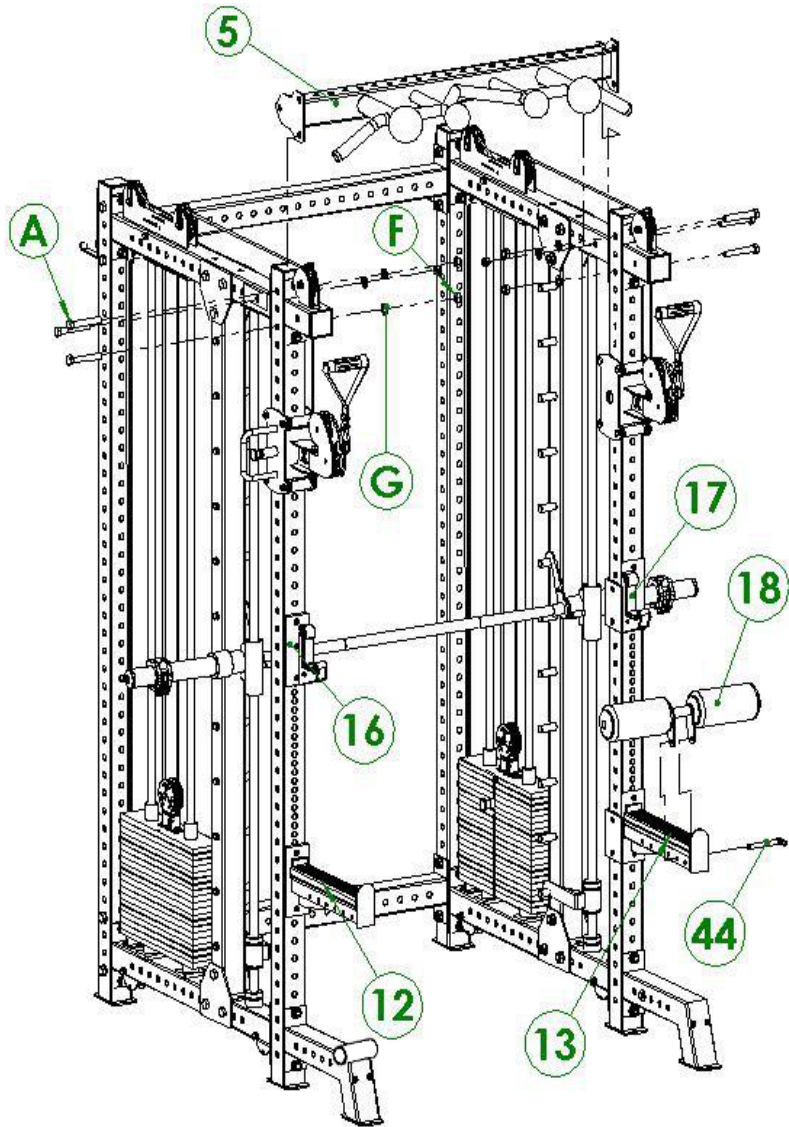
WIRE ROUTING DIAGRAMMATIC SKETCH

Assembly steps

Step NO	Item NO	Name	Qty	Item NO	Name	Qty
	NO 49	Ø90 Pulley	6	H	M10 Locknut	6
	NO 39	block pin	4	I	Ø10 Flat washer	2
	NO 43	Pully spacer sleeve	8	D	M10*45 Hexagon head screw	2

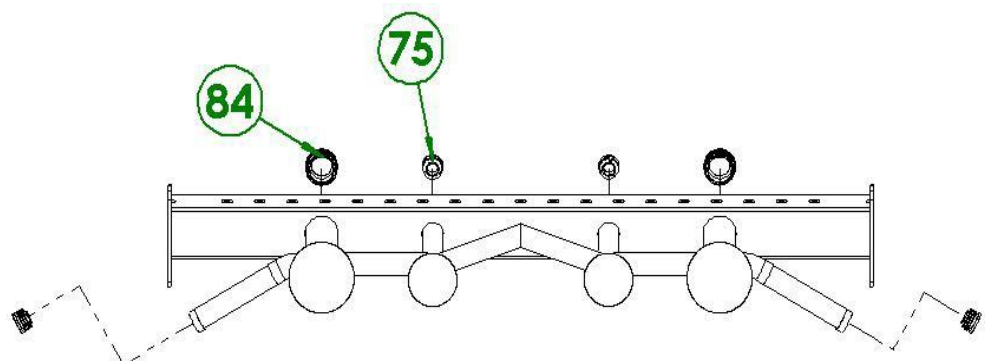


Step NO	Item NO	Name	Qty	Item NO	Name	Qty
7	NO 5	Front connection welding group	1	NO 12	Left side safety frame group	1
	NO 16	Left hook welding group	1	NO 13	Right side safety frame group	1
	NO 17	Right hook welding group	1	NO 44	T bolt	1
	NO 18	Leg press welding group	1	F	M16 Locknut	6
	A	M16*100Hexagon head screw	6	G	Φ16 Flat washer	6



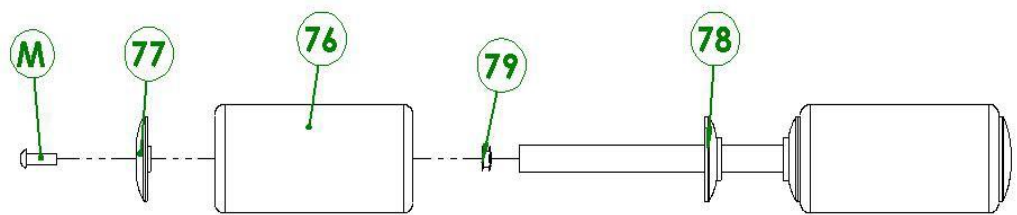
NO 5 Front connection welding group*1

Step NO	Item NO	Name	Qty	Item NO	Name	Qty
	NO 75	Round pipe plugΦ32	4			
	NO 84	Stainless steel pipe plug	2			



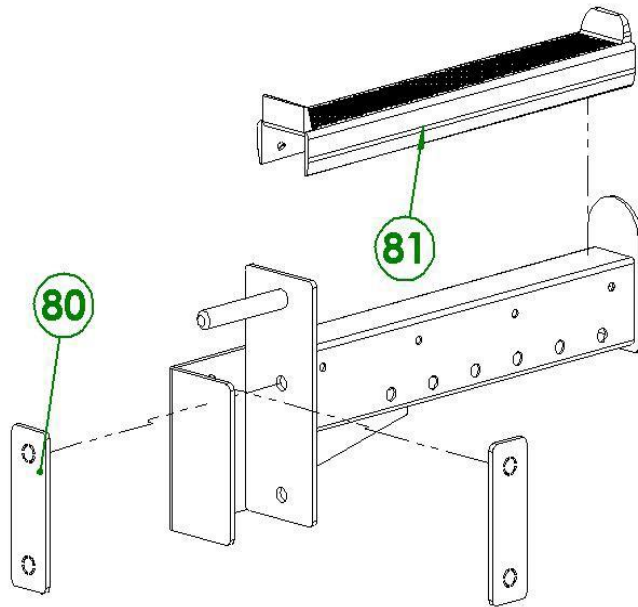
NO 18Leg press welding group*1

Step NO	Item NO	Name	Qty	Item NO	Name	Qty
	NO 76	Foam roller	2	M	Flat round head screws M10*30	2
	NO 77	Foam barrel outer cove	2			
	NO 78	Foam bucket inner lid	2			
	NO 79	Nut	2			



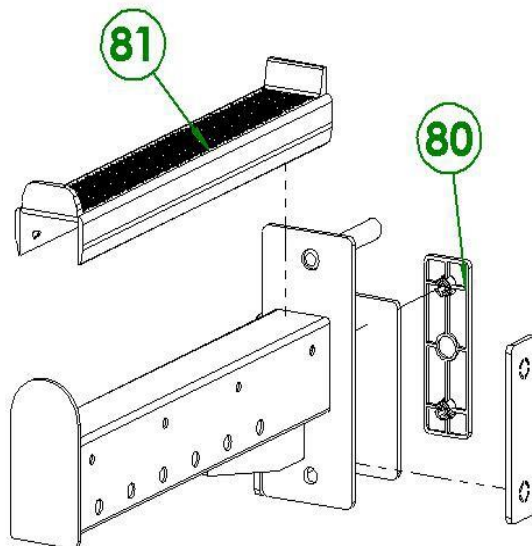
NO 12 Left fuse welding group*1

Step NO	Item NO	Name	Qty	Item NO	Name	Qty
	NO 80	Medium nylon board	2			
	NO 81	Insurance cover	1			



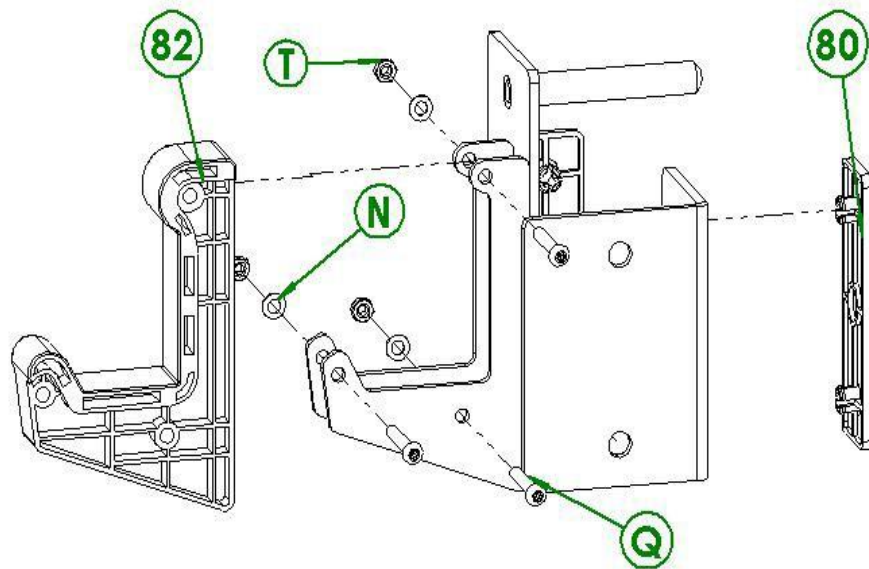
NO 13 Right fuse welding group*1

Step NO	Item NO	Name	Qty	Item NO	Name	Qty
	NO 81	Insurance cover	1			
	NO 80	Medium nylon board	2			



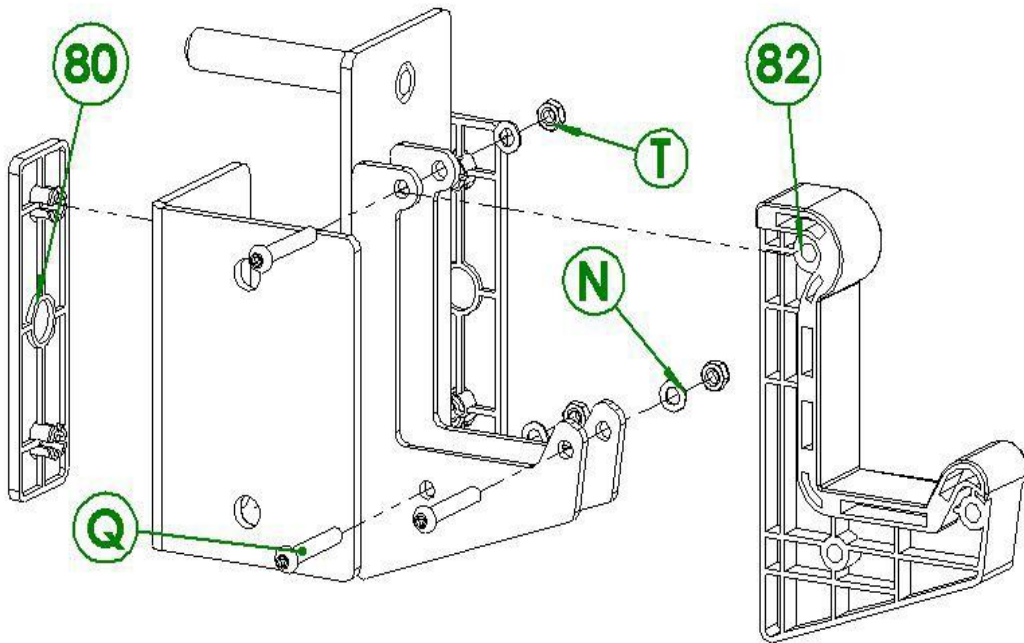
NO 16 Left Hook welding group *1

Step NO	Item NO	Name	Qty	Item NO	Name	Qty
	NO 82	Cushion	1	N	Flat washer Ø 6	3
	NO 80	Medium nylon board	2			
	Q	Hexagon socket head screw M6*40	3			
	T	Anti-loosening screw M6	3			



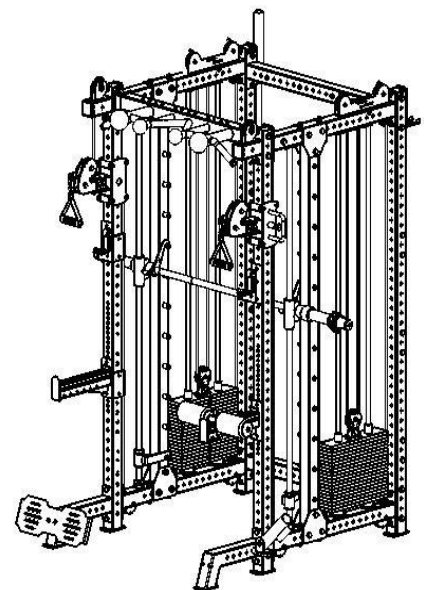
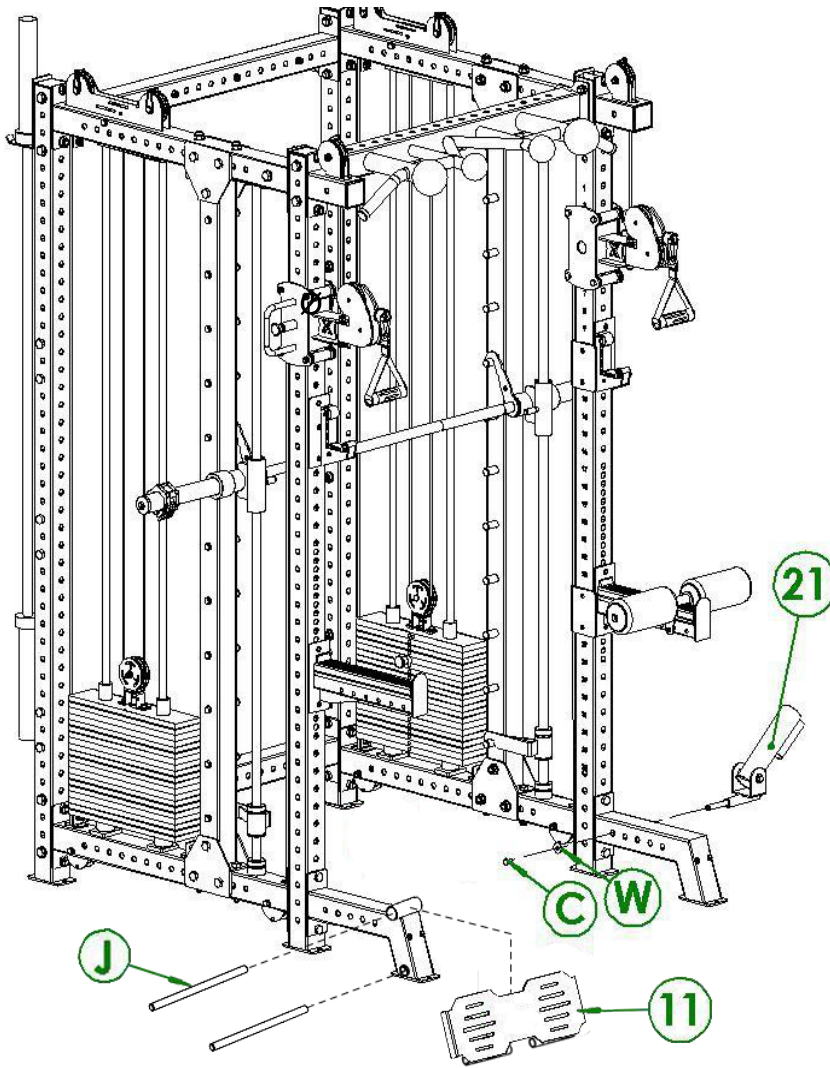
NO 17 Hook welding group right *1

Step NO	Item NO	Name	Qty	Item NO	Name	Qty
	NO 82	Cushion	1	N	Flat washer Ø 6	3
	NO 80	Medium nylon board	2			
	Q	Hexagon socket head screw M6*40	3			
	T	Anti-loosening screw M6	3			



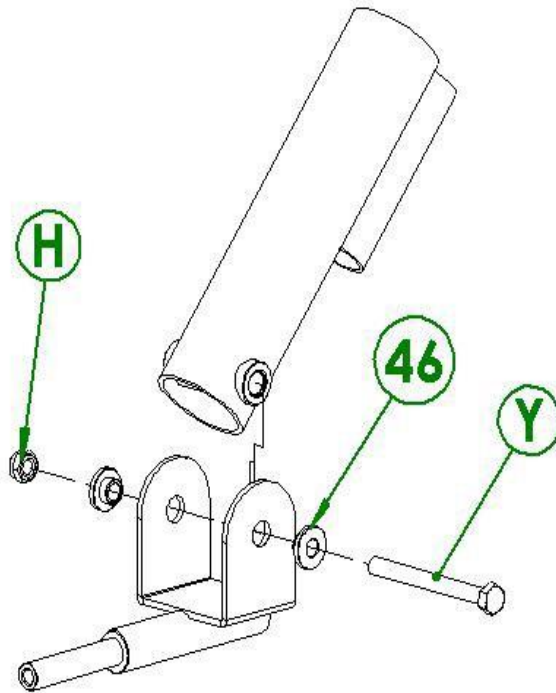
ASSEMBLY STEPS

Step NO	Item NO	Name	Qty	Item NO	Name	Qty
8	NO 11	Foot components	1	C	Hexagon screw M10*16	1
	NO 21	Landmine	1	W	Small hole big cushion	1
	J	φ25x430L fixed shaft	2			



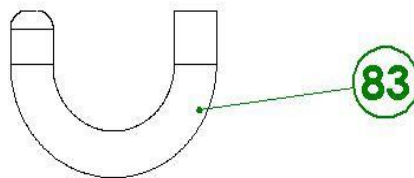
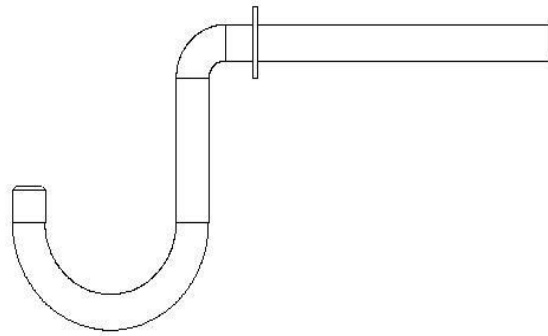
NO 21 Landmine *1

Step NO	Item NO	Name	Qty	Item NO	Name	Qty
	H	Locknut M10	1	NO 46	Nylon sleeve	2
	Y	Hexagon screw M10*100	1			



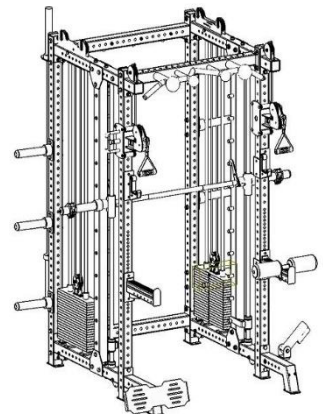
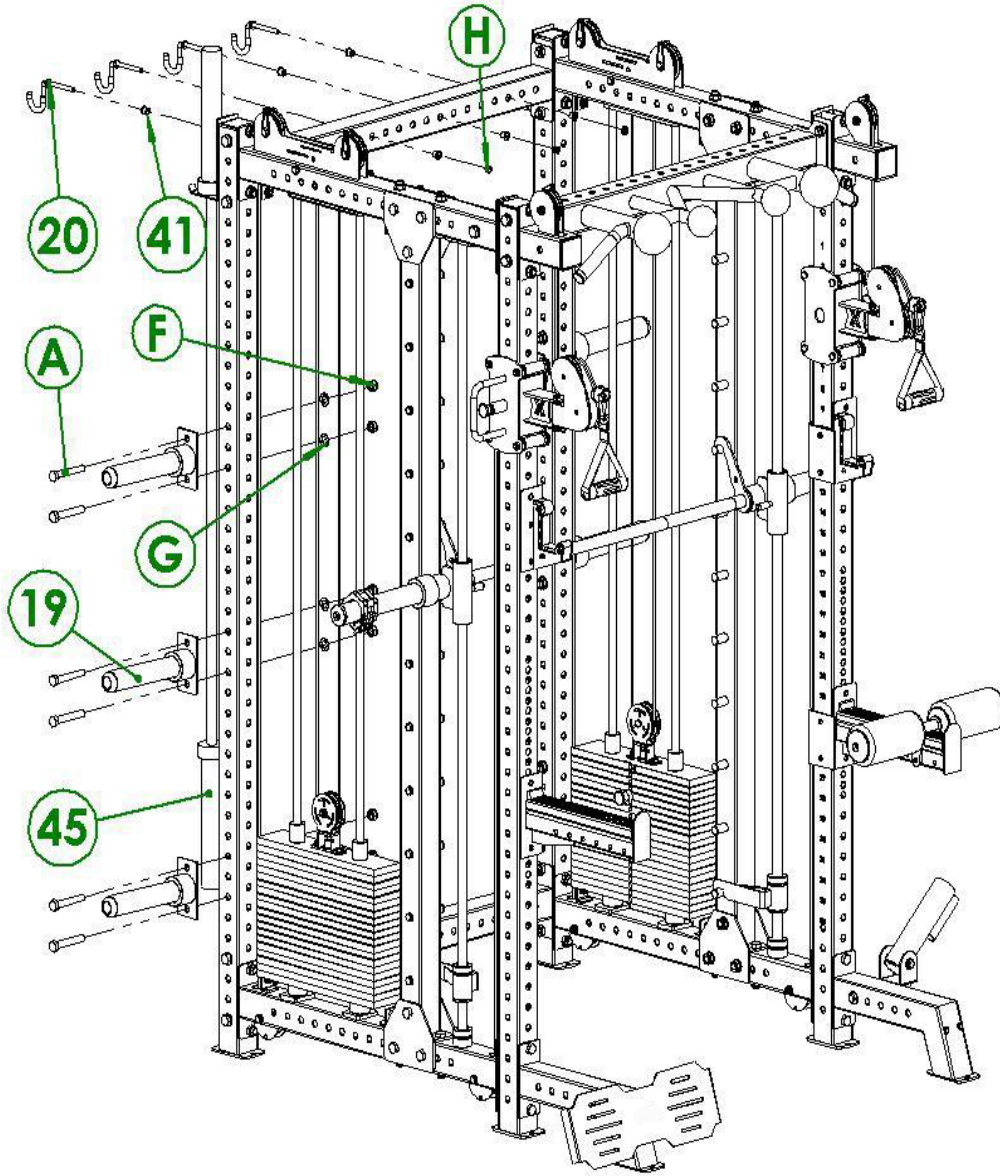
NO 20 Hook Welding *4

Step NO	Item NO	Name	Qty	Item NO	Name	Qty
	NO 83	Thumb sleeve	1			



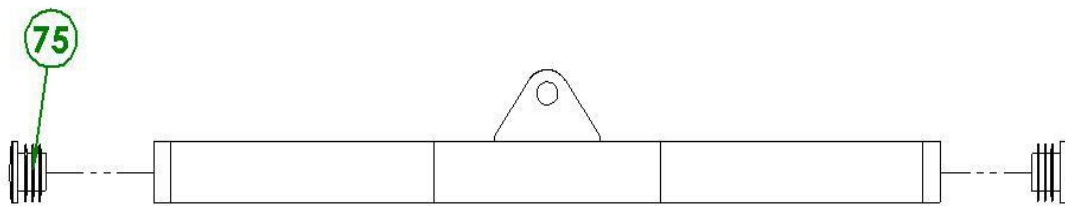
ASSEMBLY STEPS

Step NO	Item NO	Name	Qty	Item NO	Name	Qty
9	NO 20	Hook Welding	4	H	Locknut M10	4
	NO 41	Pulley limit sleeve	8	NO 19	Hanging rod welding group	6
	NO 45	Olympic bar 2.2m	1	A	Hexagon screw M16*100	12
	F	Locknut M16	12	G	Flat washer Ø16	12



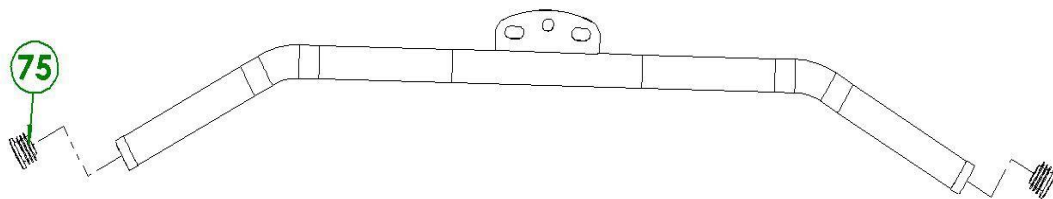
NO 23 Low pull welding group*1

Step NO	Item NO	Name	Qty	Item NO	Name	Qty
	NO 75	Round pipe plugΦ32	2			



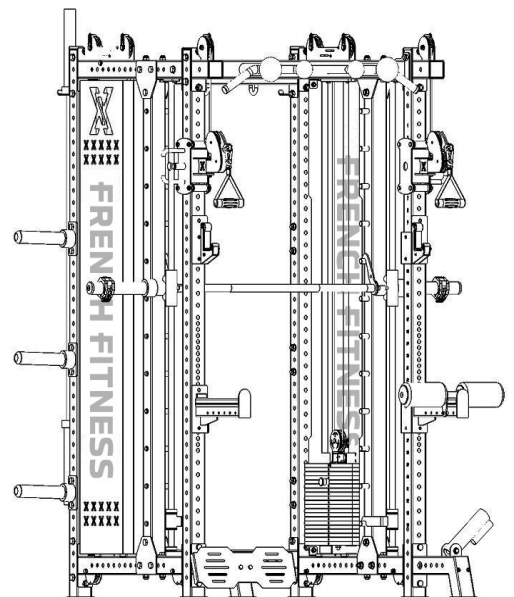
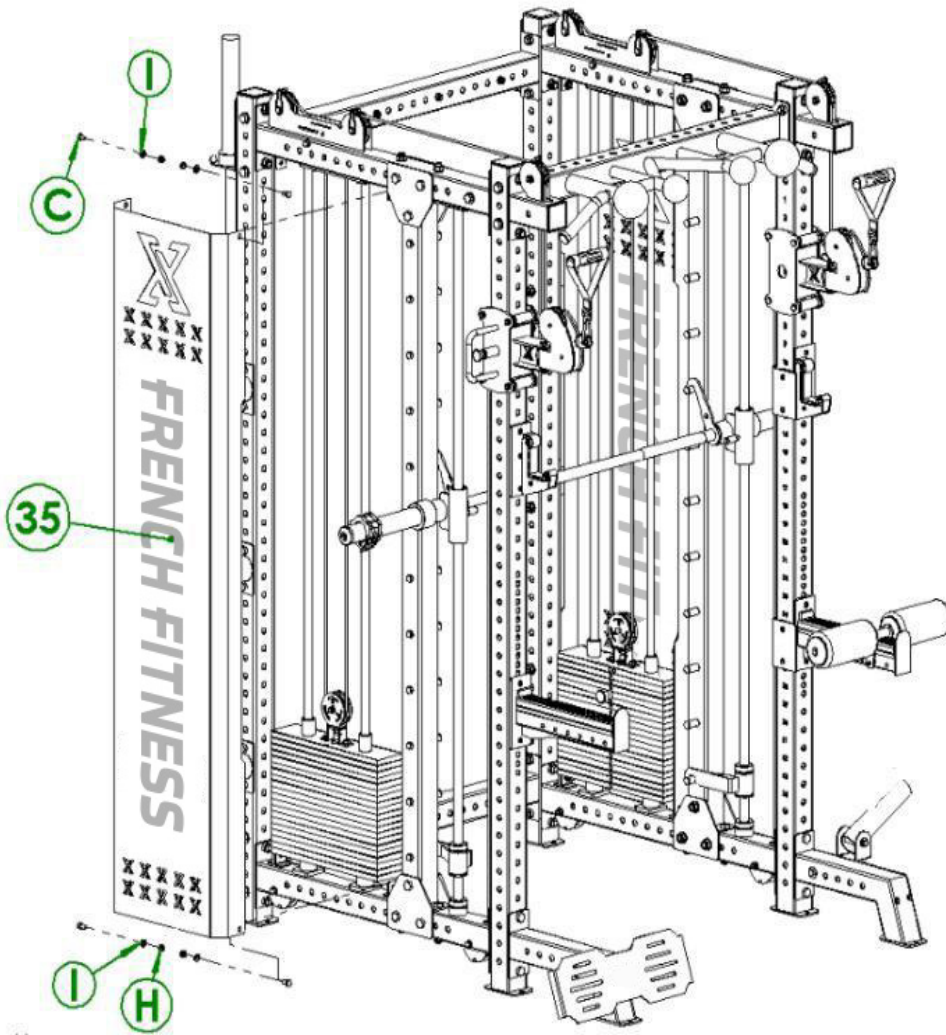
NO 24 Lat Pulldown welding *1

Step NO	Item NO	Name	Qty	Item NO	Name	Qty
	NO 75	Round pipe plugΦ32	2			



ASSEMBLY STEPS

Step NO	Item NO	Name	Qty	Item NO	Name	Qty
10	NO 35	Cover	2	H	Locknut M10	4
	I	Flat washer $\Phi 10$	4			
	C	Hexagon screw M10*16	4			



NO.19 Hanging Rod Welding Group*6

Step NO	Item NO	Name	Qty	Item NO	Name	Qty
	NO.52	Thick rubber sleeve	1			
	NO.54	Stainless steel pipe plug	1			

