

FRENCH FITNESS

Product Code: FF-FL20

Freeweight Leverage Multi-Functional Bench

ASSEMBLY MANUAL

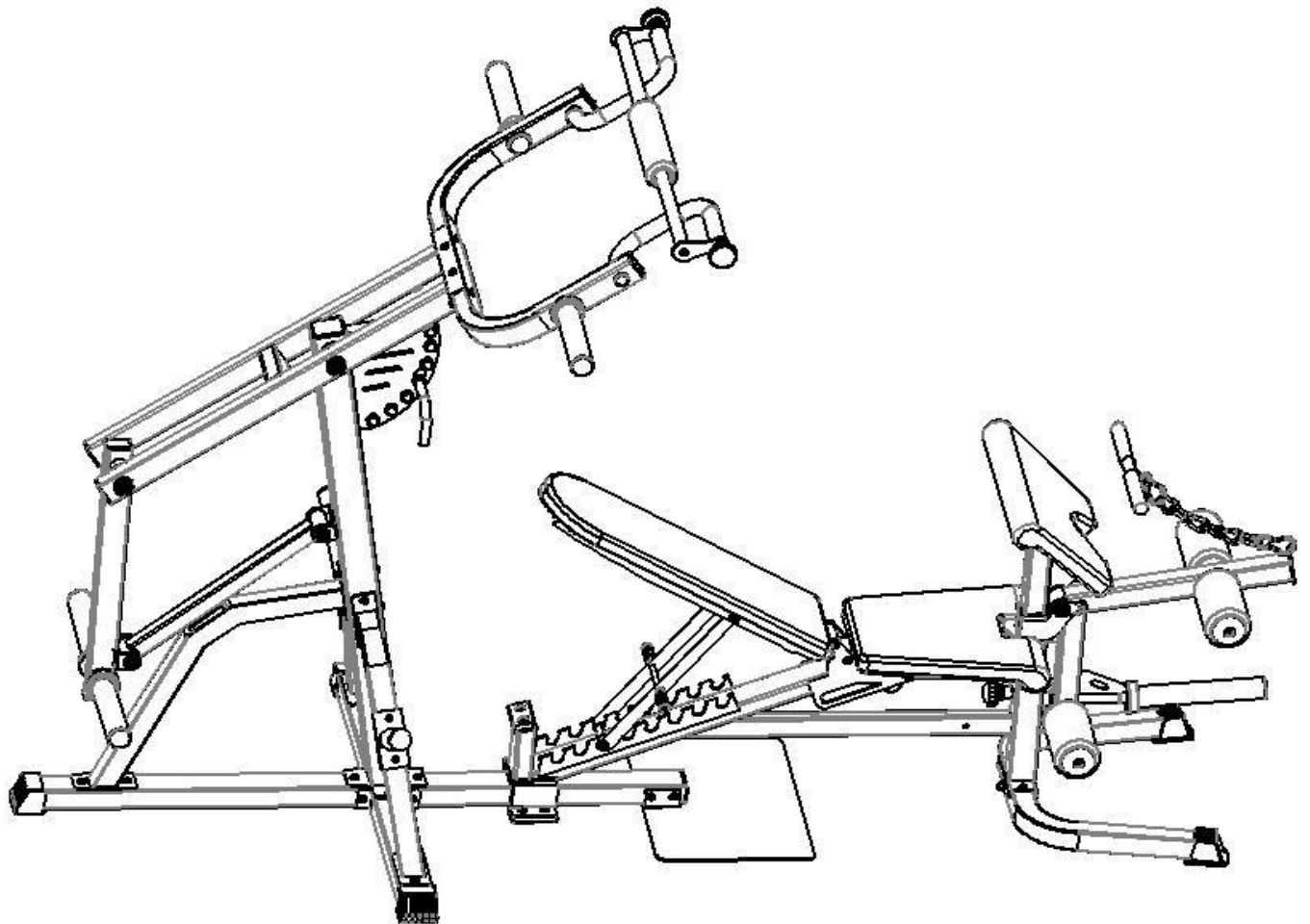

FEATURES

- The lever ensures a safe and carefully adjusted movement
- Extra thick cushion for excellent comfort during the workout
- Sturdy frame construction, powder-coated
- Each frame receives an electrostatic powder coat finish to ensure maximum adhesion and durability
- Oversized rubber feet protect base of the frame and prevent the machine from slipping
- The backrest offers 8 adjustable positions for a proper workout posture
- Use the leg extension attachment to comfortably execute leg curl and extension exercises and the preacher curl attachment with a barbell or dumbbells and build definition and size onto your arms

EXERCISES

- Forward push
- High pull (front)
- High pull (rear)
- Low pull
- Kick leg
- Standing rear kick
- Standing pull
- Crank arm pull
- Abdominal lift
- Parallel bars
- Lateral leg extension

TECH SPECS

- Weight: 298 lbs (135 kg)
- Dimensions (L x W x H): 111 in x 58 in x 56-77 in (2800 mm x 1450 mm 1400-1950 mm)



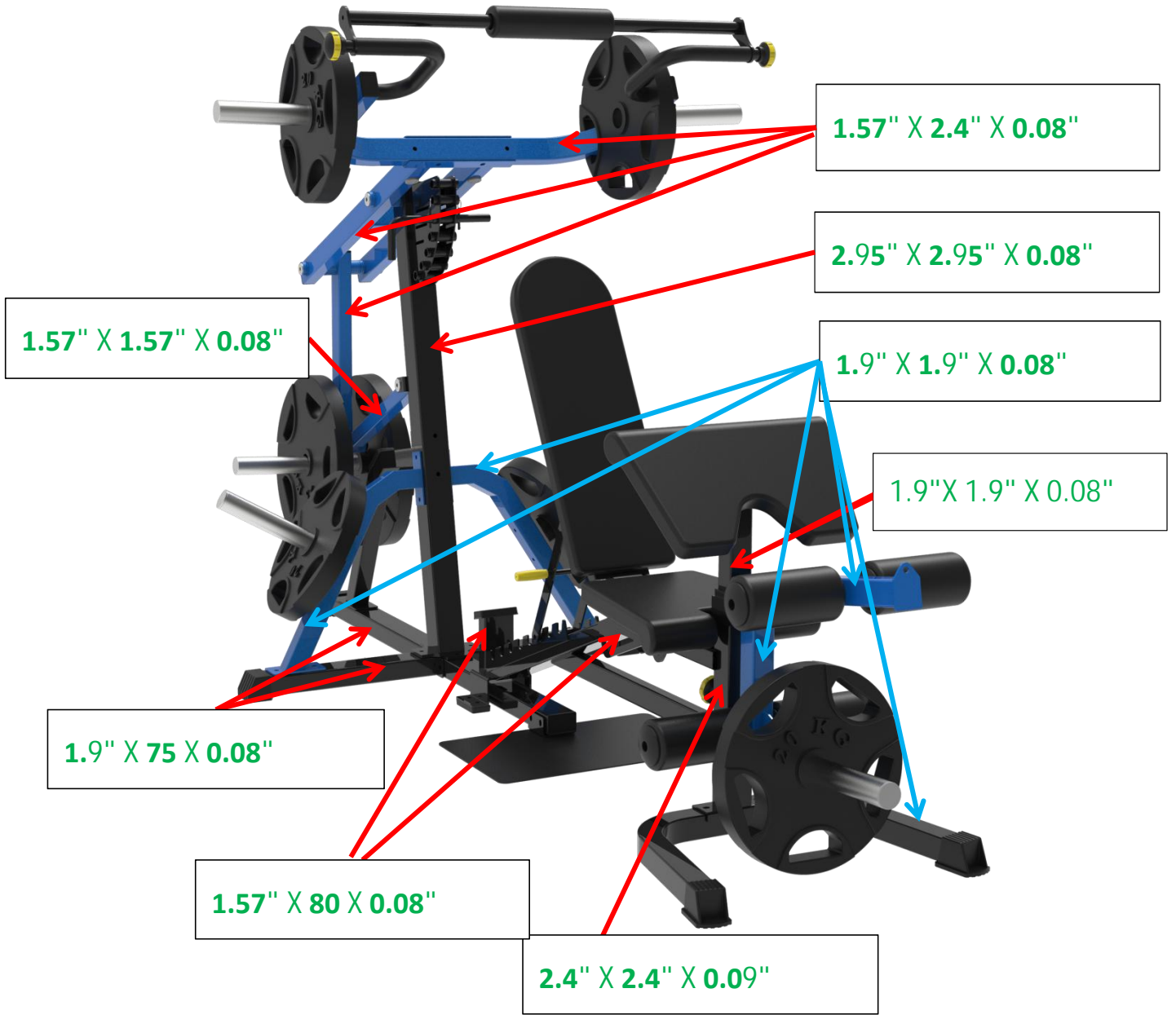

WARRANTY

- **10 Years Parts, 1 Year Labor (Light Commercial)**

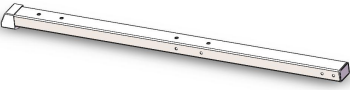
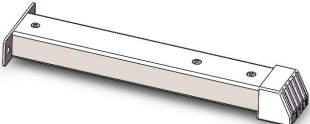
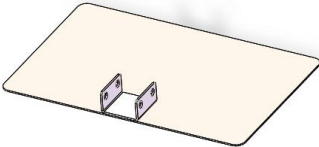
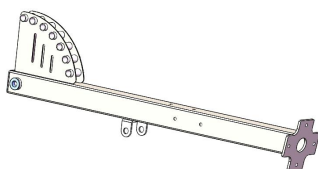
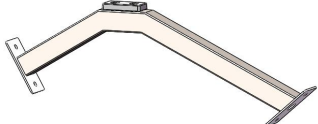
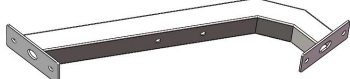
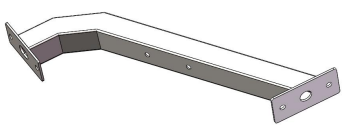
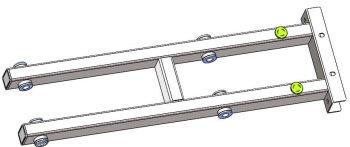
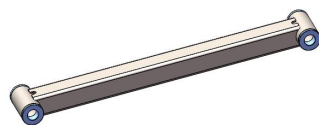
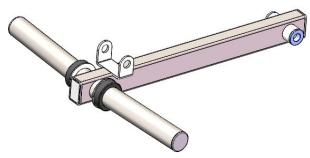

FL20

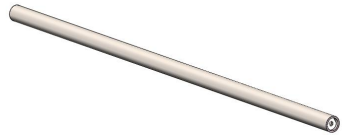
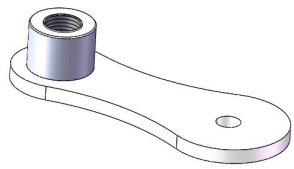

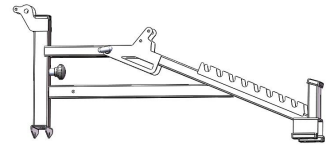
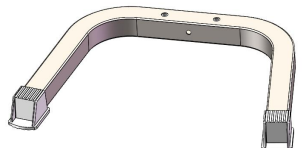
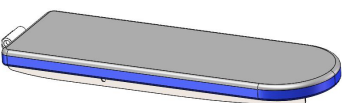
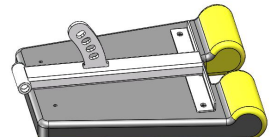



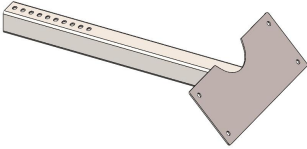
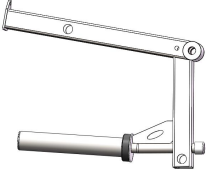

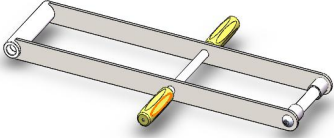
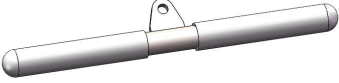
Accessories list-1 (Individual Packaging)

					
No.1	Base welding group *1	No.2	Side connection set * 2 pcs	No.3	Foot welding set *1pc
					
No.4	Large frame component *1	No.5	Back elbow welding group *1	No.6	Side bend pipe welding group left *1 piece
					
No.7	Side bend pipe welding group right *1 piece	No.8	Boom frame welding group *1	No.9	Connecting rod welding group *1
					
No.10	Boom welding group *1	No.11	Boom welding assembly*1	No.12	Squat bar assembly*1 piece
					
No.13	Lock plate welding group * 2 pieces	No.14	Barbell rod welding set * 2 pieces	No.15	Tripod assembly*1 piece
					
No.16	Front base assembly *1	No.17	Backrest component *1	No.18	Seat cushion assembly*1 piece

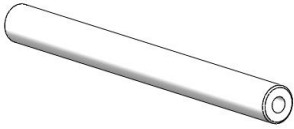
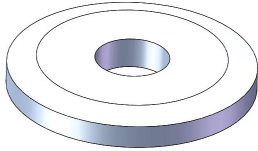
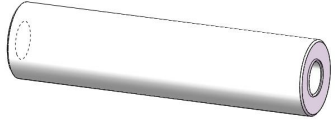
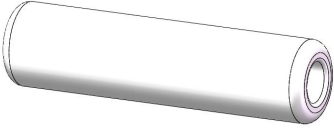
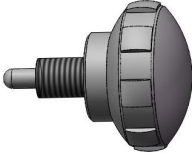

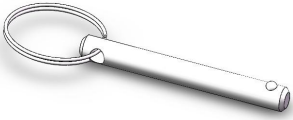
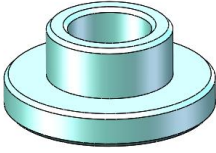
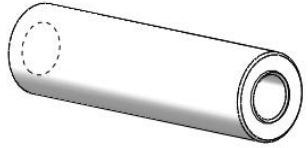
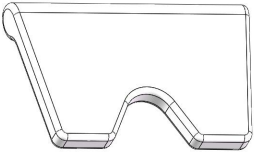
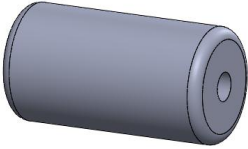

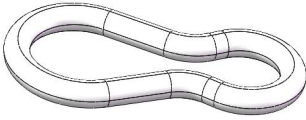
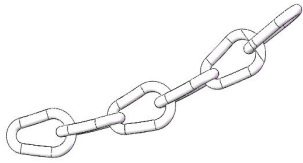
Accessories list-2 (Individual Packaging)

					
No.19	Biceps frame assembly *1	No.20	Boom assembly*1 piece	No.21	Foam rod set * 2 pieces
					
No.22	Backrest support welding group *1	No.23	Low-stretch welding group *1		

Accessories List-3 (Assembly accessories)

					
No.24	Shaft-240L*2 pieces	No.25	Gasket*10 pieces	No.26	Joint shaft-90L*2 pieces
					
No.27	Neck cushion *1 piece	No.28	Pull pin*3 pieces	No.29	Curved handle pin *1pc
					
No.30	Small bolt Φ6*2 pieces	No.31	Nylon sleeve*6 pieces	No.32	Joint shaft-69L*1 piece
					
No.33	Biceps pad *1 piece	No.34	Foam roller*4 pieces	No.35	Foam bucket inner lid*4 pieces
					
No.36	Foam barrel outer cover*4 pieces	No.37	Standard safety hook*2pcs	No.38	Chain *1pc
					
No.39	Ball pin *1pc	No.40		No.41	

Blister Pack Screw List-5 (standard parts)

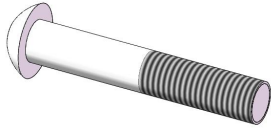
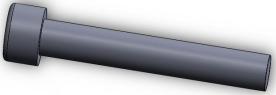
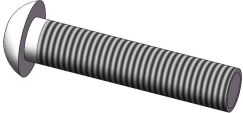
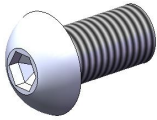
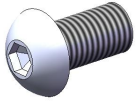
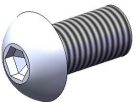
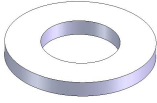
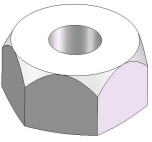
					
A	Hexagon socket flat head screw M10*150*1	B	Hexagon socket flat head screw M10*100*2pcs	C	Hexagon socket flat head screw M10*95*6pcs
					
D	Hexagon socket flat head screw M10*90*2pcs	E	Hexagon socket flat head screw M10*80*2pcs	F	Hexagon socket flat head screw M10*75*1pc
					
G	Hexagon socket flat head screw M10*65*4pcs	H	Hexagon socket flat head screw M10*55*2pcs	I	Hexagon socket flat head screw M10*20*26pcs
					
J	Hexagon socket flat head screw M10*25*4pcs	K	Hexagon socket flat head screw M8*25*4pcs	L	Flat gasket Ø10*18pcs
					
M	Lock nut M10*18pcs				

Main frame assembly steps

Step No.	Item No.	Name	Quantity	Item No.	Name	Quantity
1	No.1	Base Welding Group	1	M	M10 Lock Nut	2
	No.2	Side Connection Group	2			
	C	M10*95 Hexagon Socket Flat Head Screw	2			
	L	Ø10 Flat Gasket	2			
Tools/Equipment		6#Inner hexagon screwdriver, wrench				

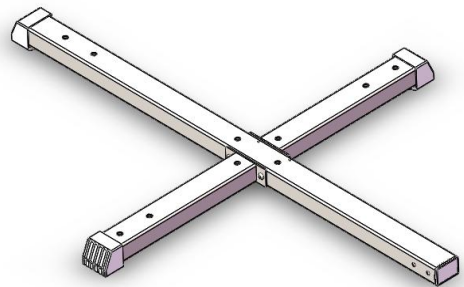
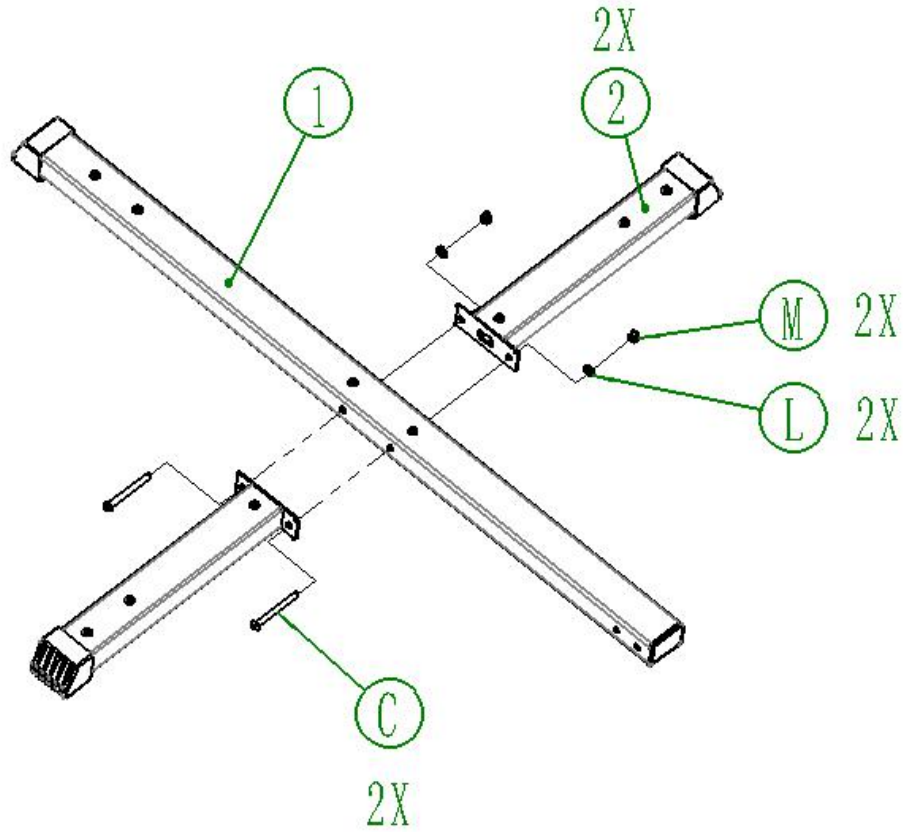

Main frame assembly steps

Step No.	Item No.	Name	Quantity	Item No.	Name	Quantity
2	No.3	Foot welding group	1			
	C	M10*95 Hexagon Socket Flat Head Screw	2			
	L	Ø10 Flat Gasket	2			
	M	M10 Lock Nut	2			
Tools/Equipment		6# Inner hexagon screwdriver, wrench				

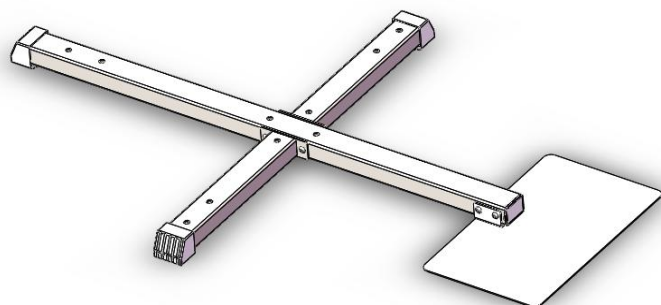
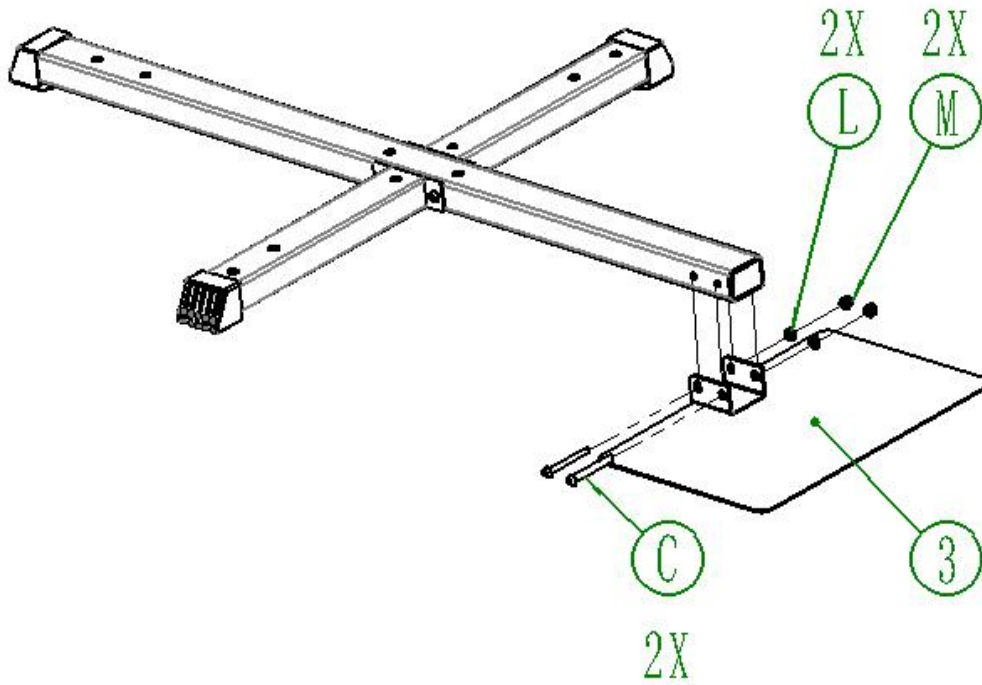

Main frame assembly steps

Step No.	Item No.	Name	Quantity	Item No.	Name	Quantity
3	NO.4	Large frame	1			
	I	M10*20 Hexagon Socket Flat Head Screw	4			

Tools/Equipment

6#Inner hexagon screwdriver

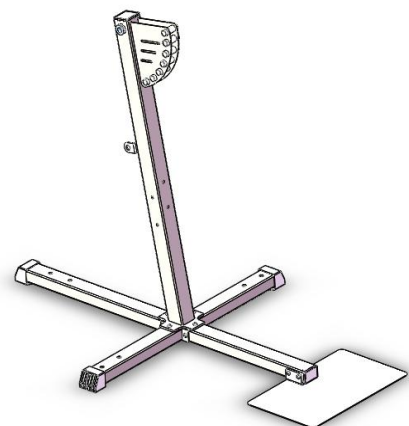
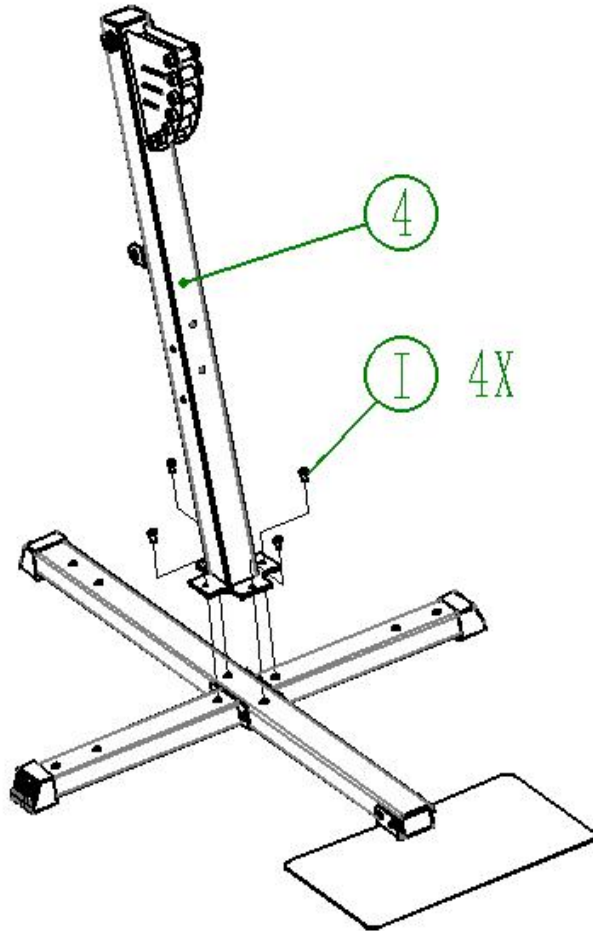

Main frame assembly steps

Step No.	Item No.	Name	Quantity	Item No.	Name	Quantity
4	No.5	Back elbow welding group	1	I	M10*20 Hexagon Socket Flat Head Screw	2
	D	M10*90 Hexagon Socket Flat Head Screw	2			
	L	Ø10 Flat Gasket	2			
	M	M10 Lock Nut	2			
Tools/Equipment		6#Inner hexagon screwdriver, wrench				

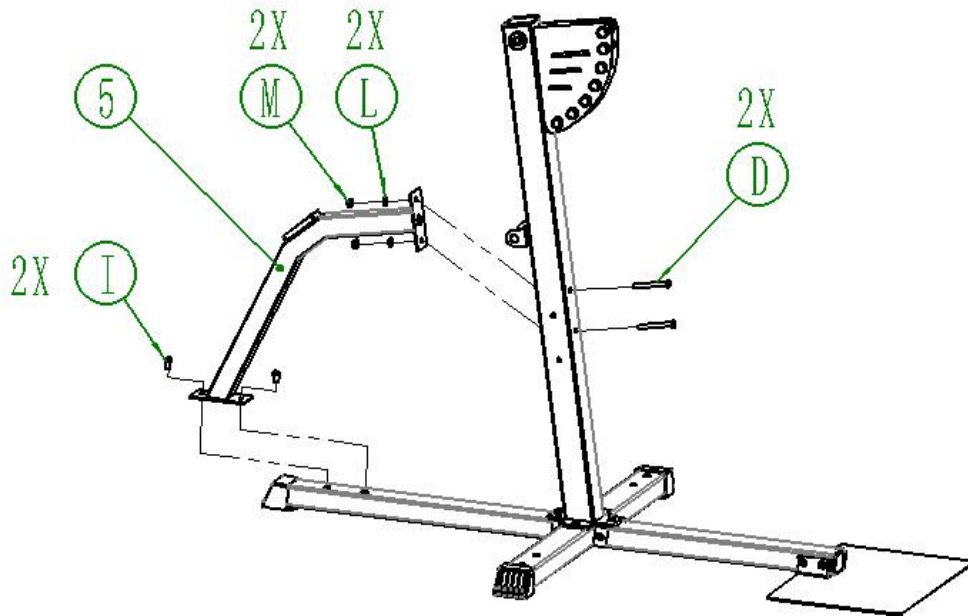

Main frame assembly steps

Step No.	Item No.	Name	Quantity	Item No.	Name	Quantity
5	6号	Side bend pipe welding	1	L	Ø10Flat gasket	2
	7号	Side bend pipe welding	1	M	M10 lock nut	2
	C	M10*95 Hexagon socket flat head screws	2			
	I	M10*20 Hexagon socket flat head screws	4			

Tools/Equipment

6#Inner hexagon screwdriver, wrench

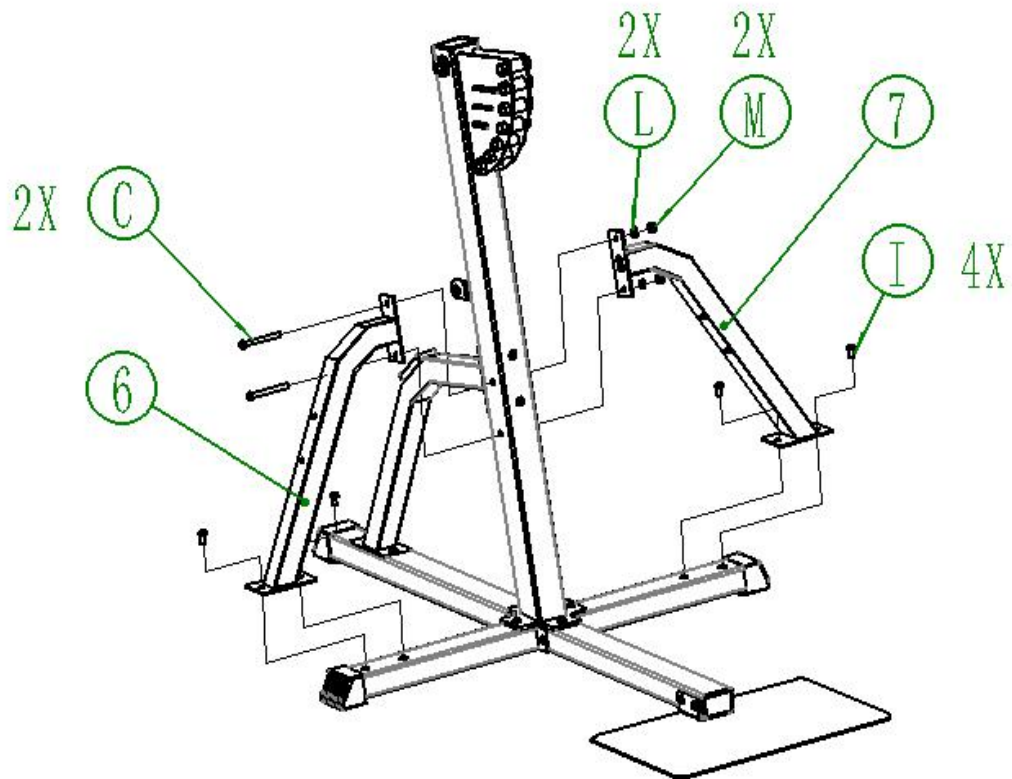

Main frame assembly steps

Step No.	Item No.	Name	Quantity	Item No.	Name	Quantity
6	No.8	Boom frame welding	1			
	No.24	Shaft	1			
	No.25	Gasket	2			
	I	M10*20 Hexagon socket flat head screws	2			
Tools/Equipment		6#Inner hexagon screwdriver				



Main frame assembly steps

Step No.	Item No.	Name	Quantity	Item No.	Name	Quantity
7	No.9	Connecting rod welding	1			
	No.25	Gasket	2			
	No.26	Joint axis	1			
	I	M10*20 Hexagon socket flat head screws	2			

Tools/Equipment 6#Inner hexagon screwdriver

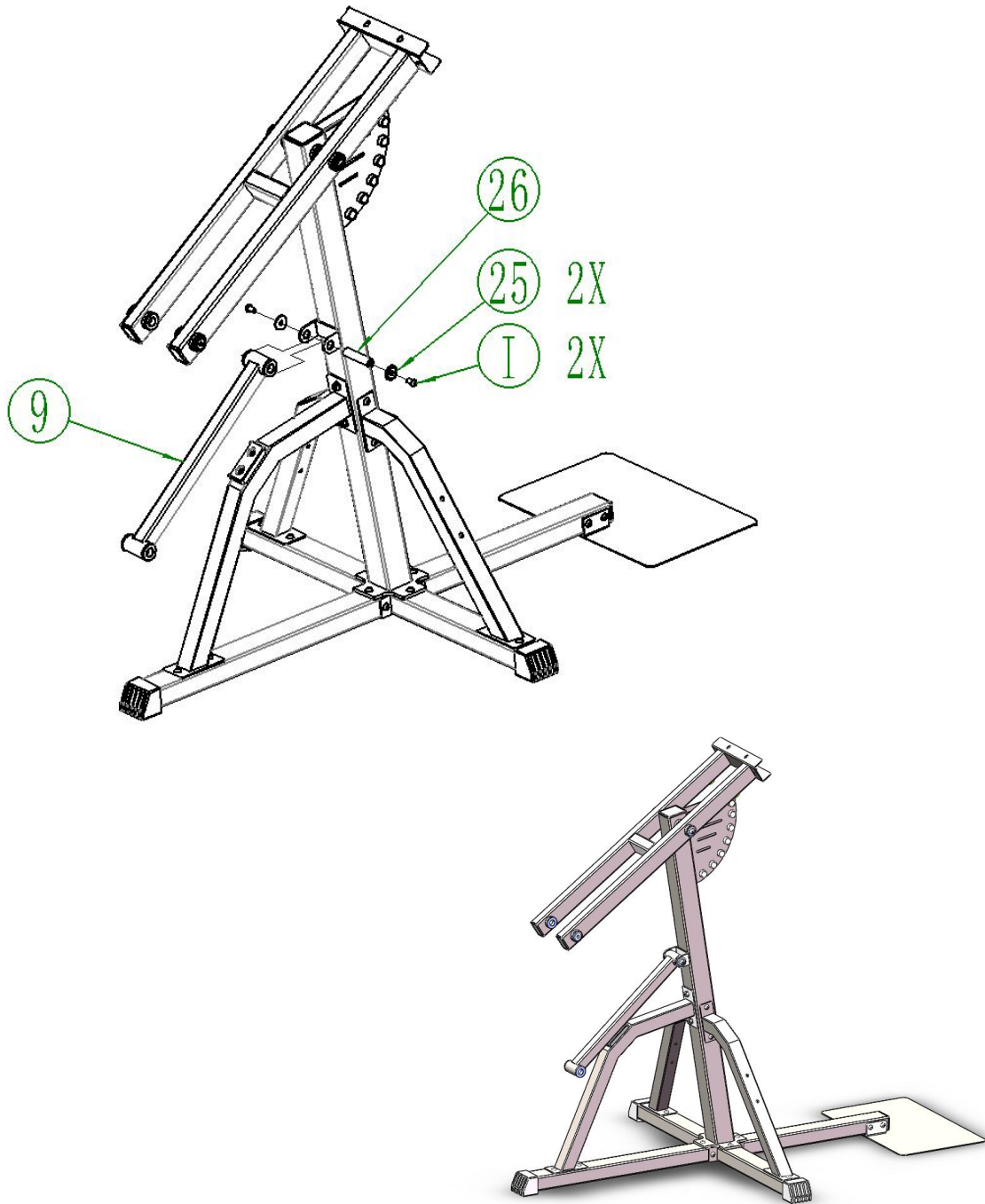

Main frame assembly steps

Step No.	Item No.	Name	Quantity	Item No.	Name	Quantity
8	No.10	Boom welding group	1	I	M10*20 Hexagon socket flat head screws	4
	No.24	Shaft	1			
	No.25	Gasket	4			
	No.26	Joint axis	1			
Tools/Equipment		6#Inner hexagon screwdriver				

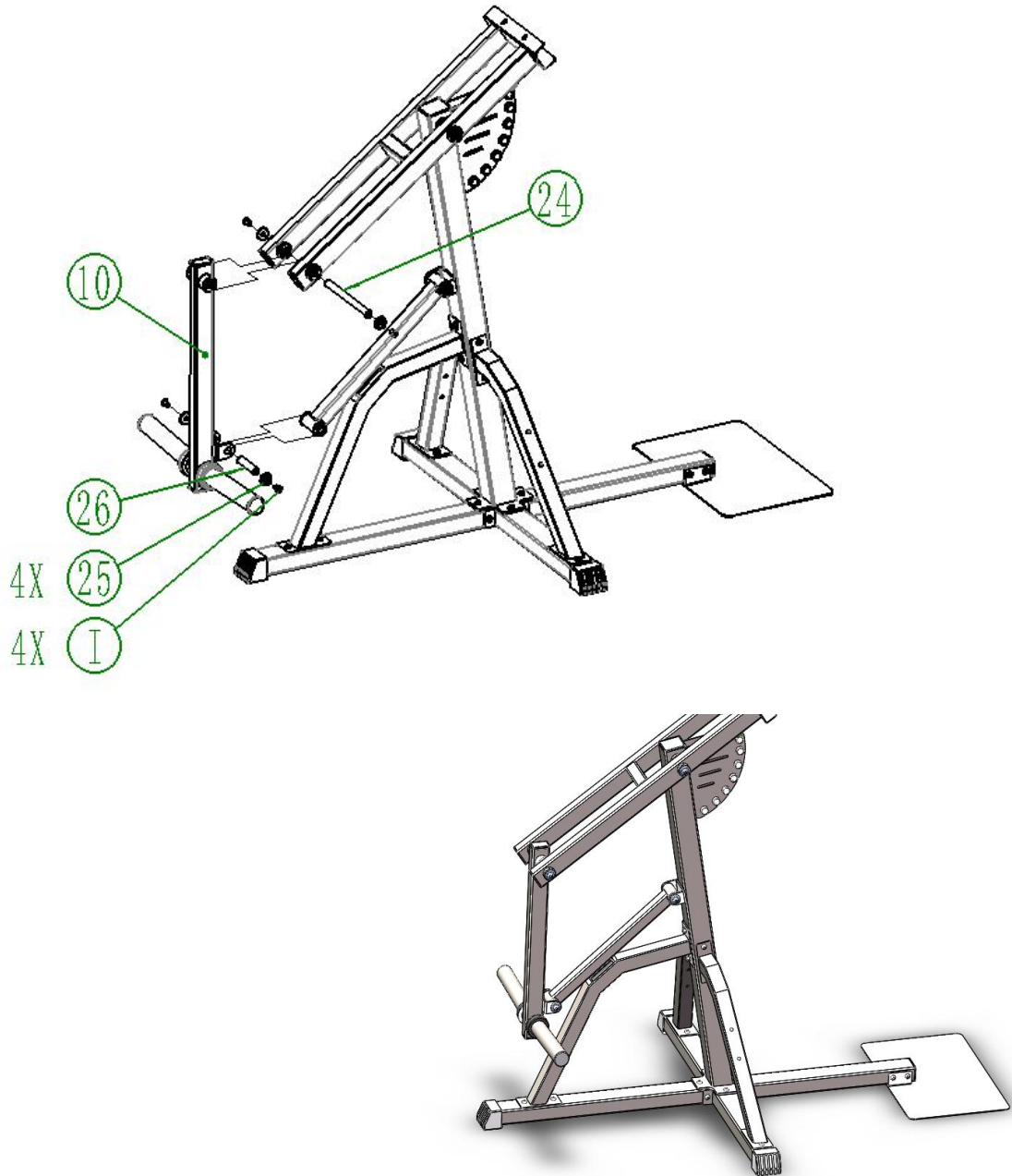

Main frame assembly steps

Step No.	Item No.	Name	Quantity	Item No.	Name	Quantity
9	No.11	Boom frame welding	1	M	M10 lock nut	4
	E	M10*80 Hexagon socket flat head screws	2			
	H	M10*55 Hexagon socket flat head screws	2			
	L	Ø10 Flat gasket	4			
Tools/Equipment		6#Inner hexagon screwdriver, wrench				

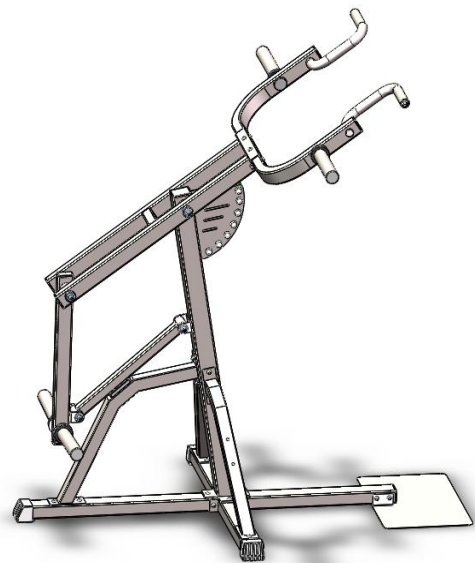
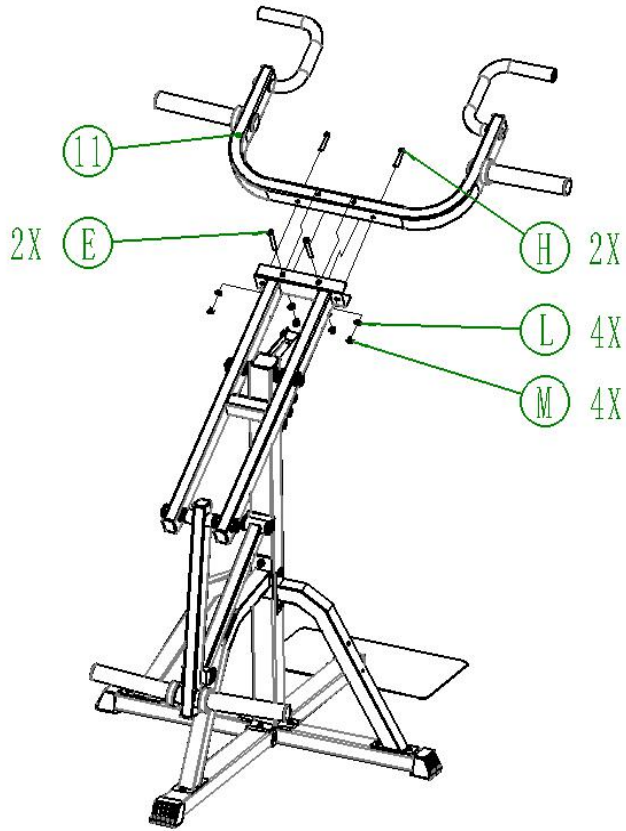

Main frame assembly steps

Step No.	Item No.	Name	Quantity	Item No.	Name	Quantity
10	No.12	Squat bar assembly	1	I	M10*20Hexagon socket flat head screws	2
	No.13	Lock plate welding	2			
	No.27	Neck cushion	1			
	No.28	Pull pin	2			

Tools/Equipment 6#Inner hexagon screwdriver

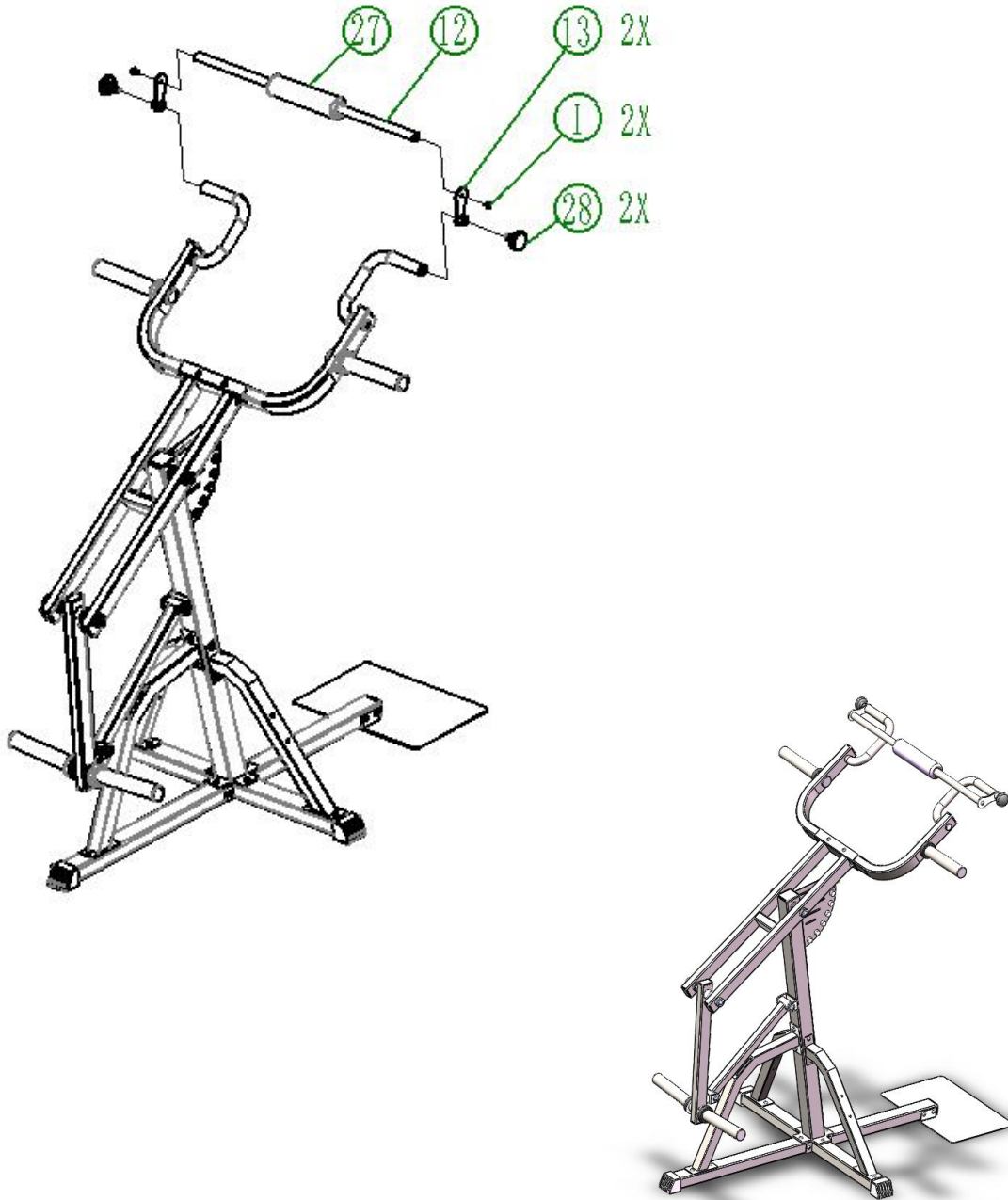

Main frame assembly steps

Step No.	Item No.	Name	Quantity	Item No.	Name	Quantity
11	No.14	Barbell bar welding	2	L	Ø10Flat gasket	4
	No.29	Curved handle latch	1	M	M10Lock Nut	4
	No.30	Small latch	2			
	G	M10*65 Hexagon socket flat head screws	4			
Tools/Equipment		6#Inner hexagon screwdriver, wrench				

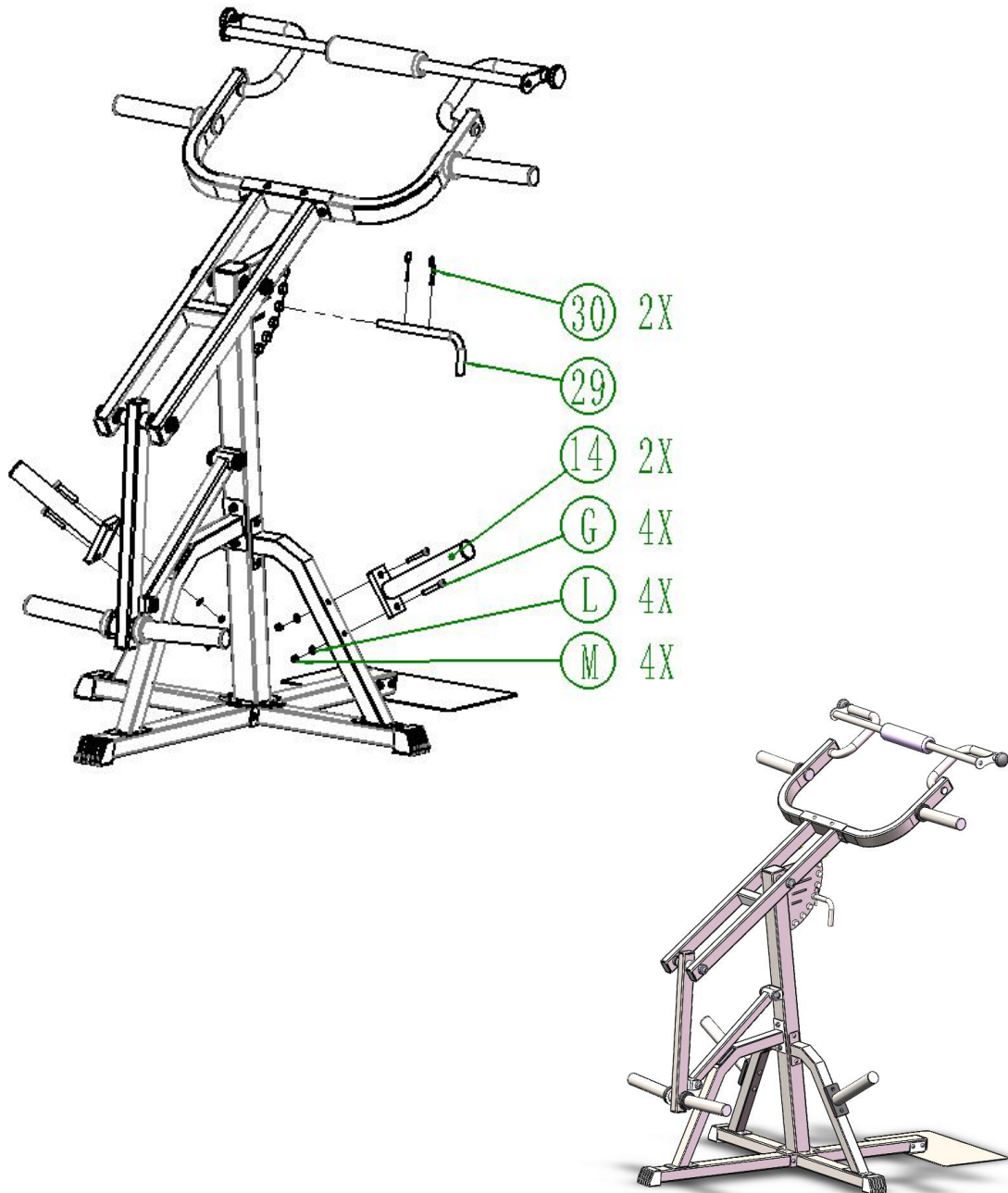

Dumbbell Bench Assembly Steps

Step No.	Item No.	Name	Quantity	Item No.	Name	Quantity
1	No.15	Tripod assembly	1	L	Ø10 Flat Gasket	1
	No.16	Front base assembly	1	M	M10 Lock Nut	1
	I	M10*20 Hexagon socket flat head screws	2			
	F	M10*75 Hexagon socket flat head screws	1			

Tools/Equipment 6# Inner hexagon screwdriver, wrench

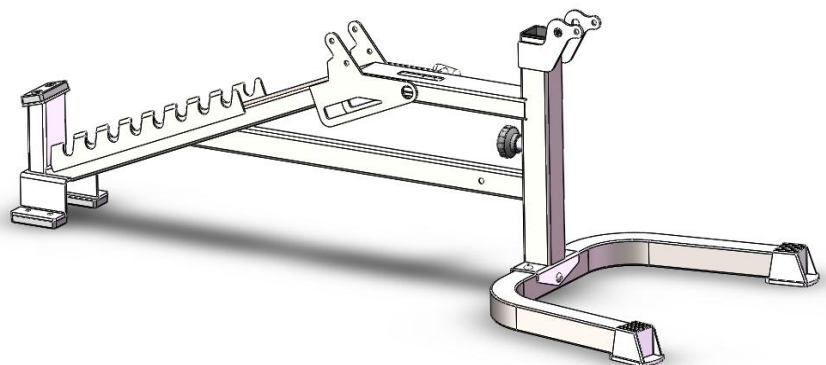
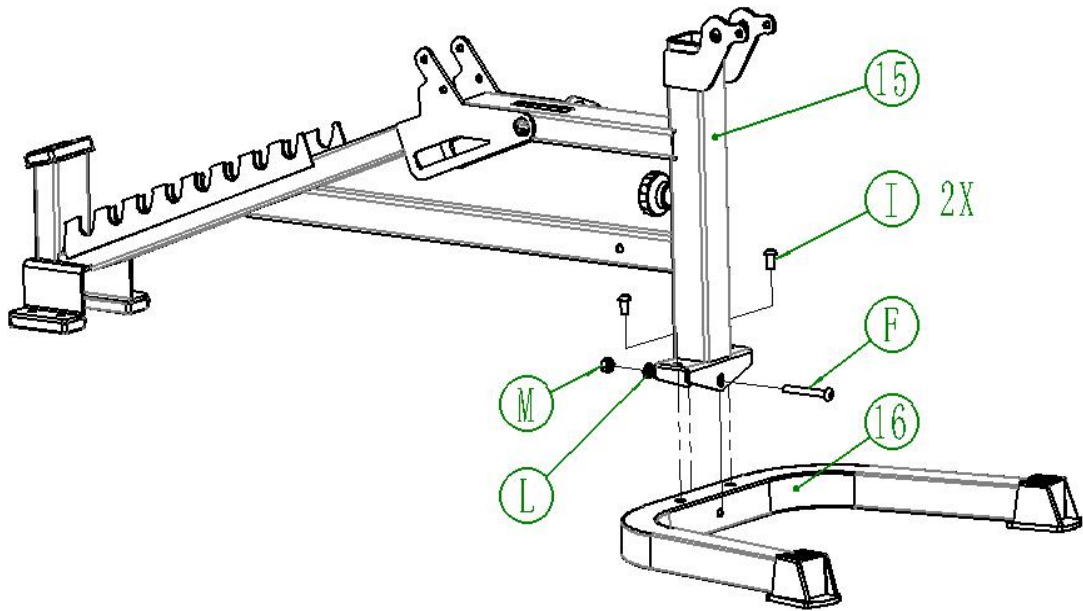

Dumbbell Bench Assembly Steps

Step No.	Item No.	Name	Quantity	Item No.	Name	Quantity
2	No.17	Backrest components	1	M	M10 Locknut	1
	No.31	Nylon sleeve	2			
	B	M10*100 Hexagon socket flat head screws	1			
	L	Ø10 Flat gasket	1			

Tools/Equipment

6#Inner hexagon screwdriver, wrench

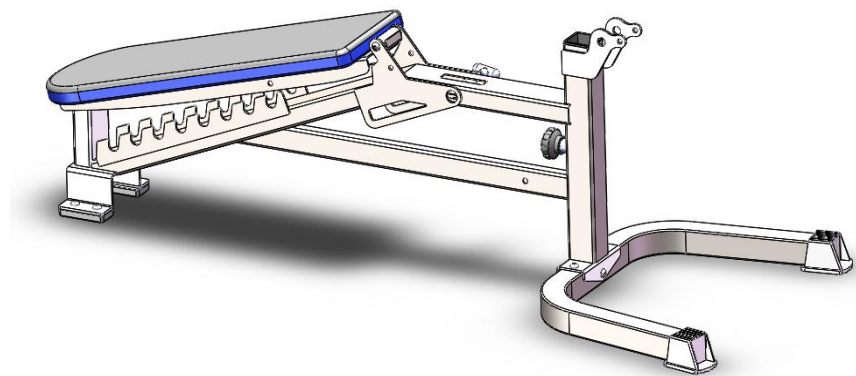
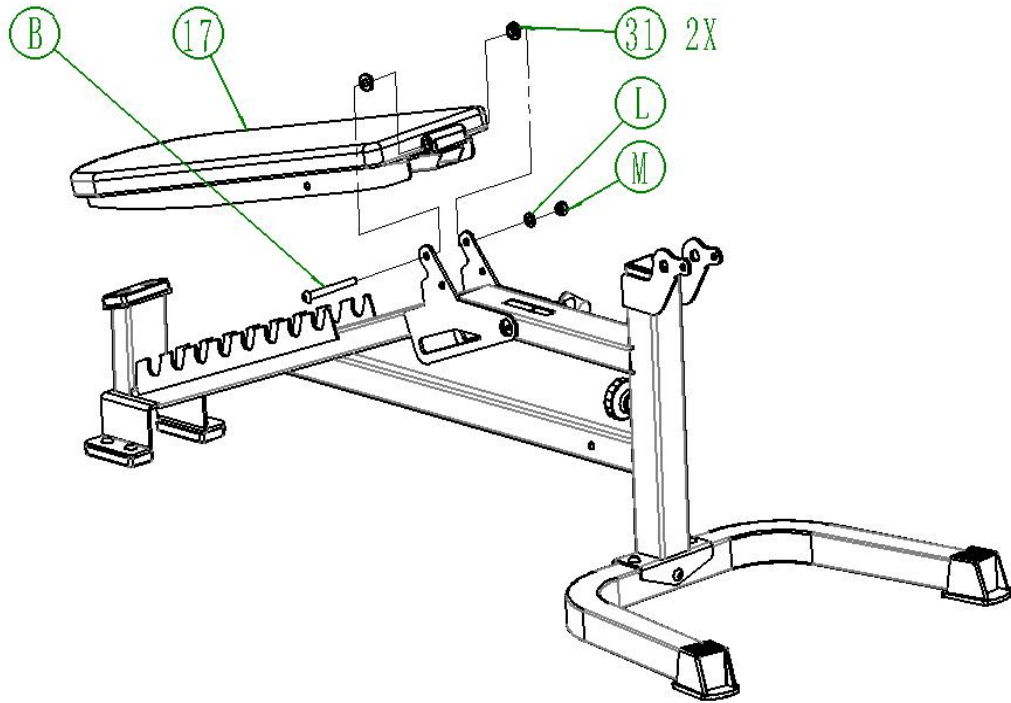

Dumbbell Bench Assembly Steps

Step No.	Item No.	Name	Quantity	Item No.	Name	Quantity
3	No.22	Backrest support	1	M	M10 Locknut	1
	No.31	Nylon sleeve	2			
	A	M10*150 Hexagon socket flat head screws	1			
	L	Ø10 Flat gasket	1			

Tools/Equipment

6#Inner hexagon screwdriver, wrench

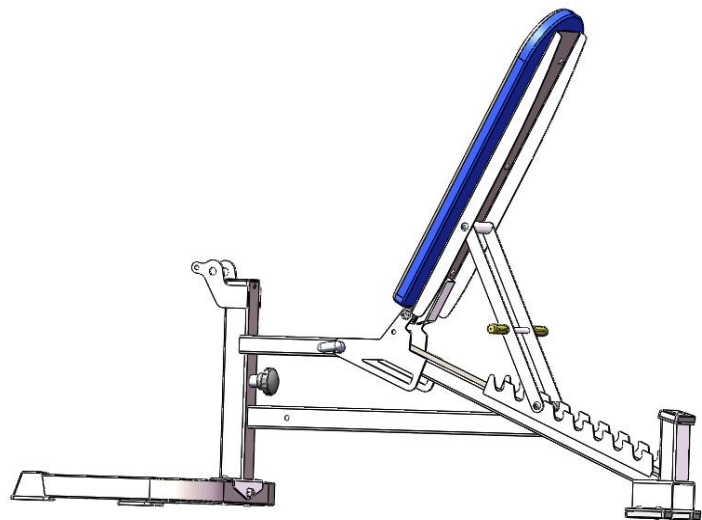
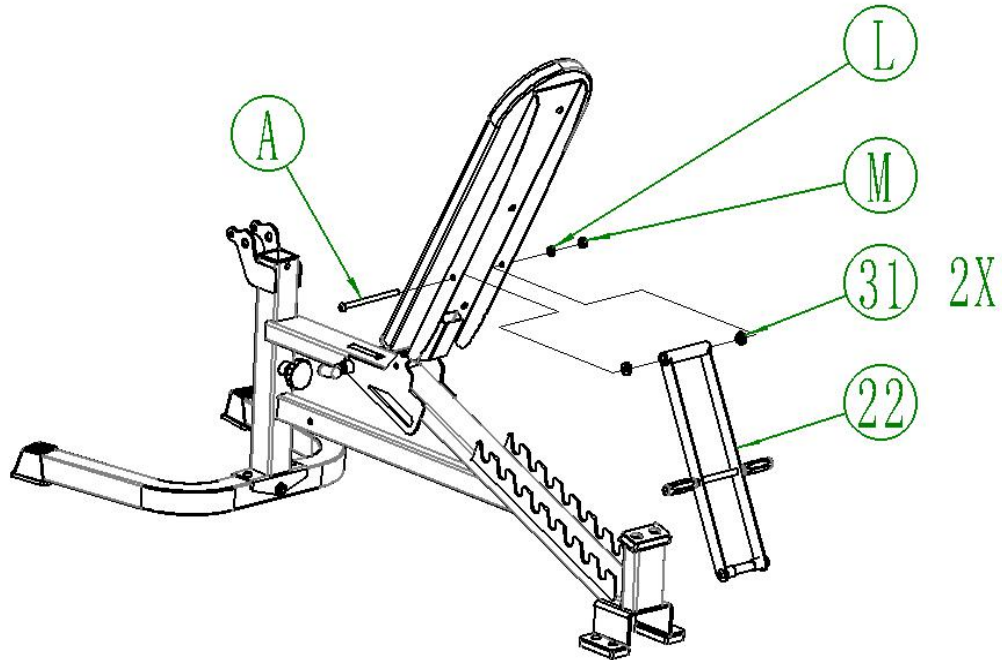

Dumbbell Bench Assembly Steps

Step No.	Item No.	Name	Quantity	Item No.	Name	Quantity
4	No.18	Seat cushion	1	M	M10 Locknut	1
	No.31	Nylon sleeve	2			
	B	M10*100 Hexagon socket flat head screws	1			
	L	Ø10 Flat gasket	1			

Tools/Equipment

6#Inner hexagon screwdriver, wrench

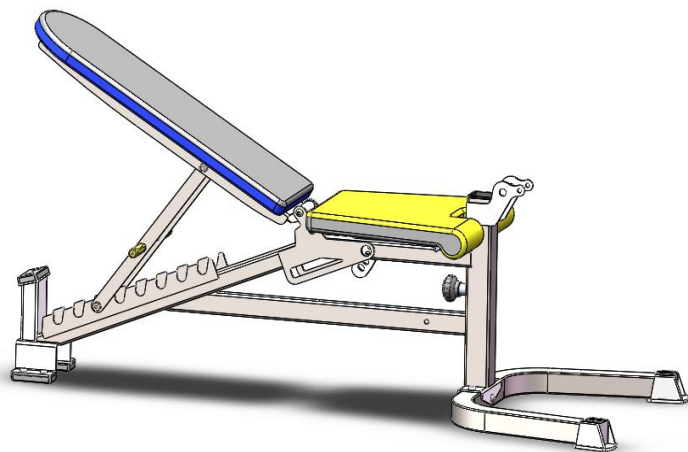
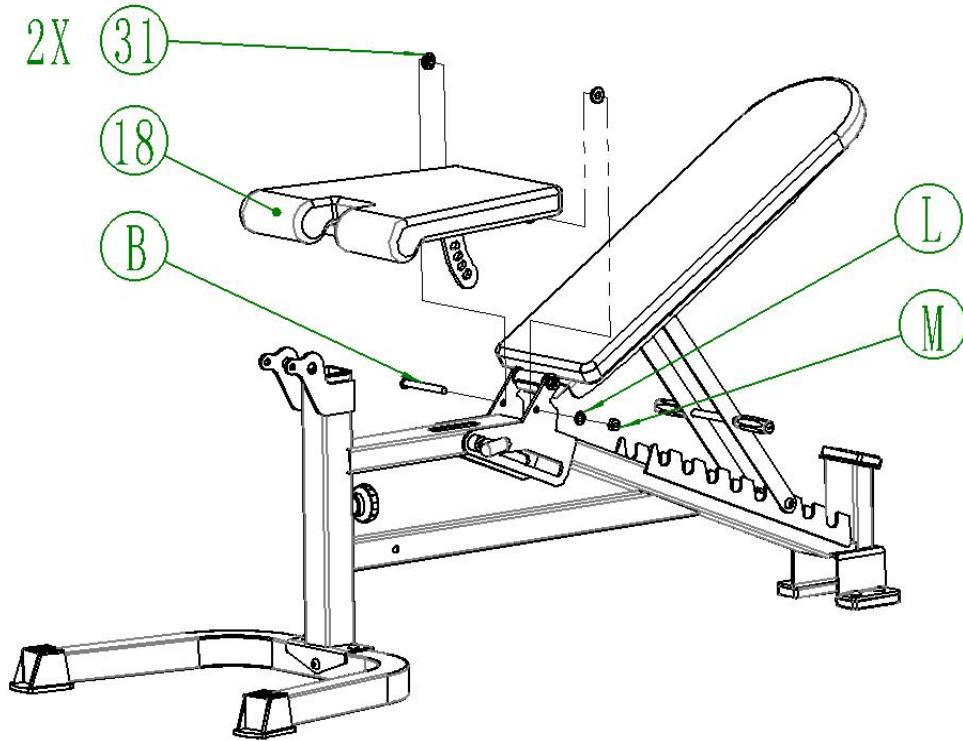

Dumbbell Bench Assembly Steps

Step No.	Item No.	Name	Quantity	Item No.	Name	Quantity
5	No.20	Boom assembly	1			
	No.25	Gasket	2			
	No.32	Joint axis	1			
	I	M10*20 Hexagon socket flat head screws	2			
Tools/Equipment		6#Inner hexagon screwdriver				

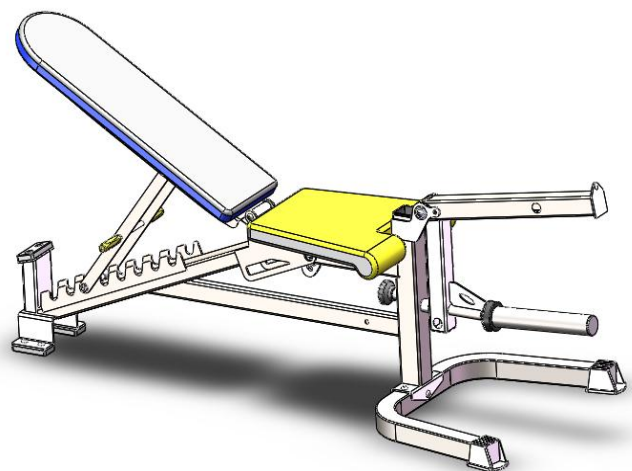
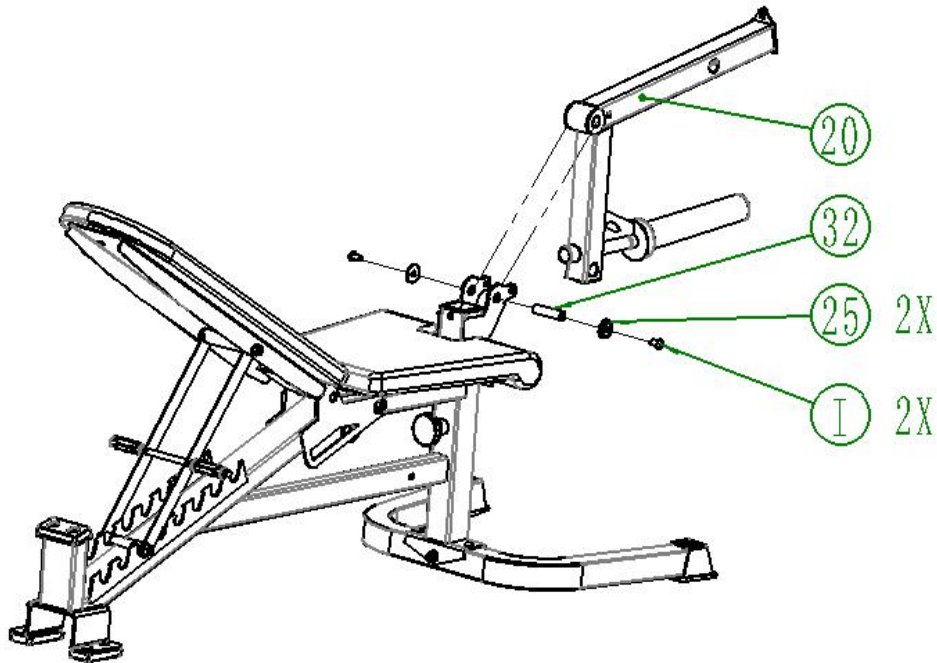

Dumbbell Bench Assembly Steps

Step No.	Item No.	Name	Quantity	Item No.	Name	Quantity
6	No.19	Biceps frame	1			
	No.33	Biceps pad	1			
	K	M8*25 Hexagon socket flat head screws	4			

Tools/Equipment 5#Inner hexagon screwdriver

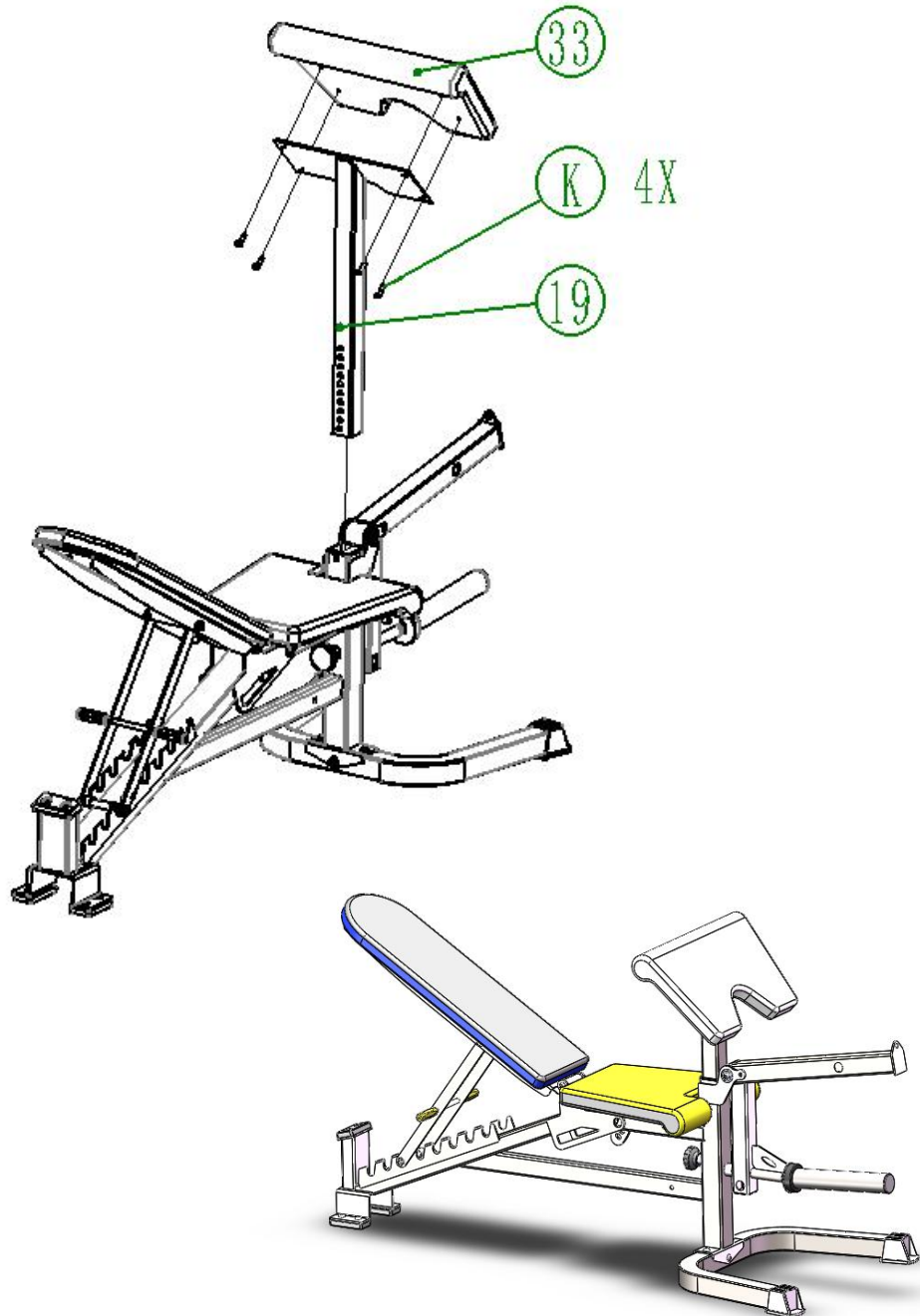

Dumbbell Bench Assembly Steps

Step No.	Item No.	Name	Quantity	Item No.	Name	Quantity
7	No.21	Foam rod set	2	J	M10*25 Hexagon socket flat head screws	4
	No.34	Foam roller	4			
	No.35	Foam bucket lid	4			
	No.36	Foam barrel outer cover	4			

Tools/Equipment 6#Inner hexagon screwdriver

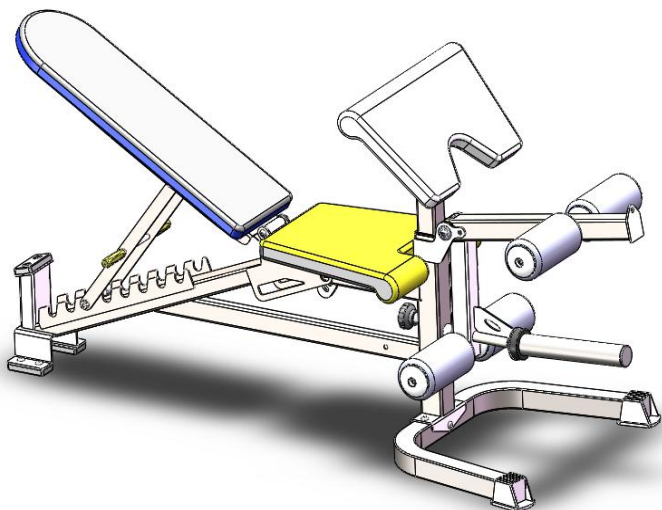
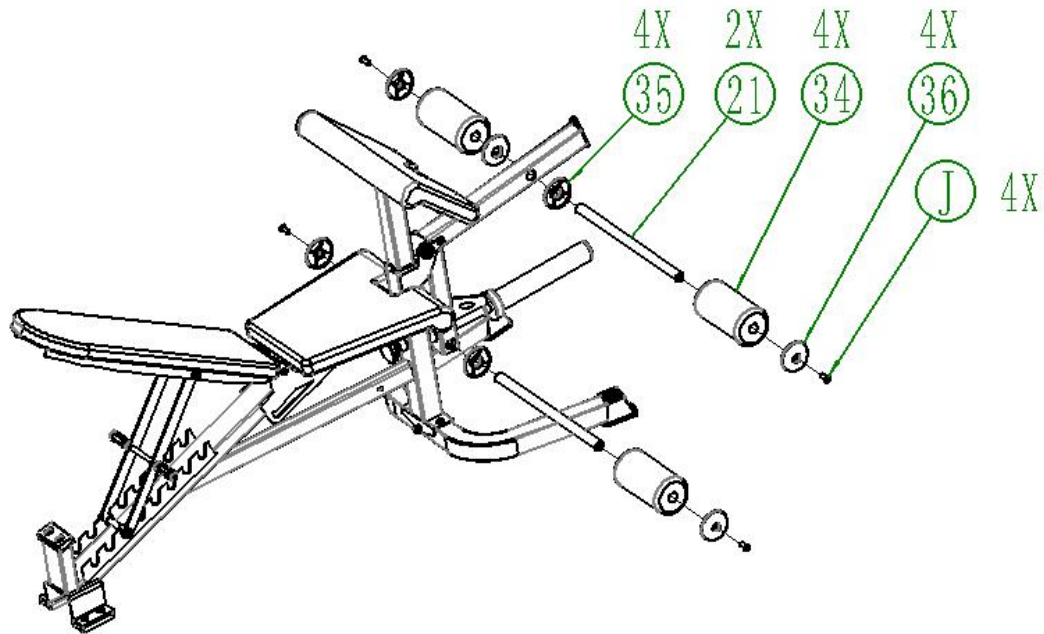

Dumbbell Bench Assembly Steps

Step No.	Item No.	Name	Quantity	Item No.	Name	Quantity
8	No.23	Low pull handle	1			
	No.37	Standard safety hook	2			
	No.38	Chain	1			
	No.39	Ball bolt	1			

Tools/Equipment

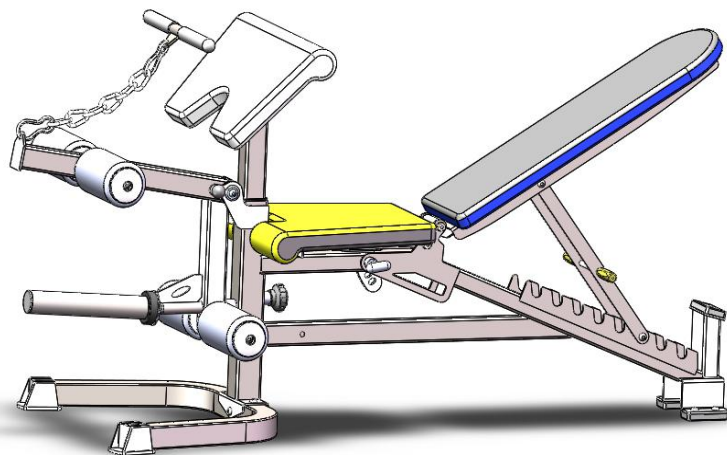
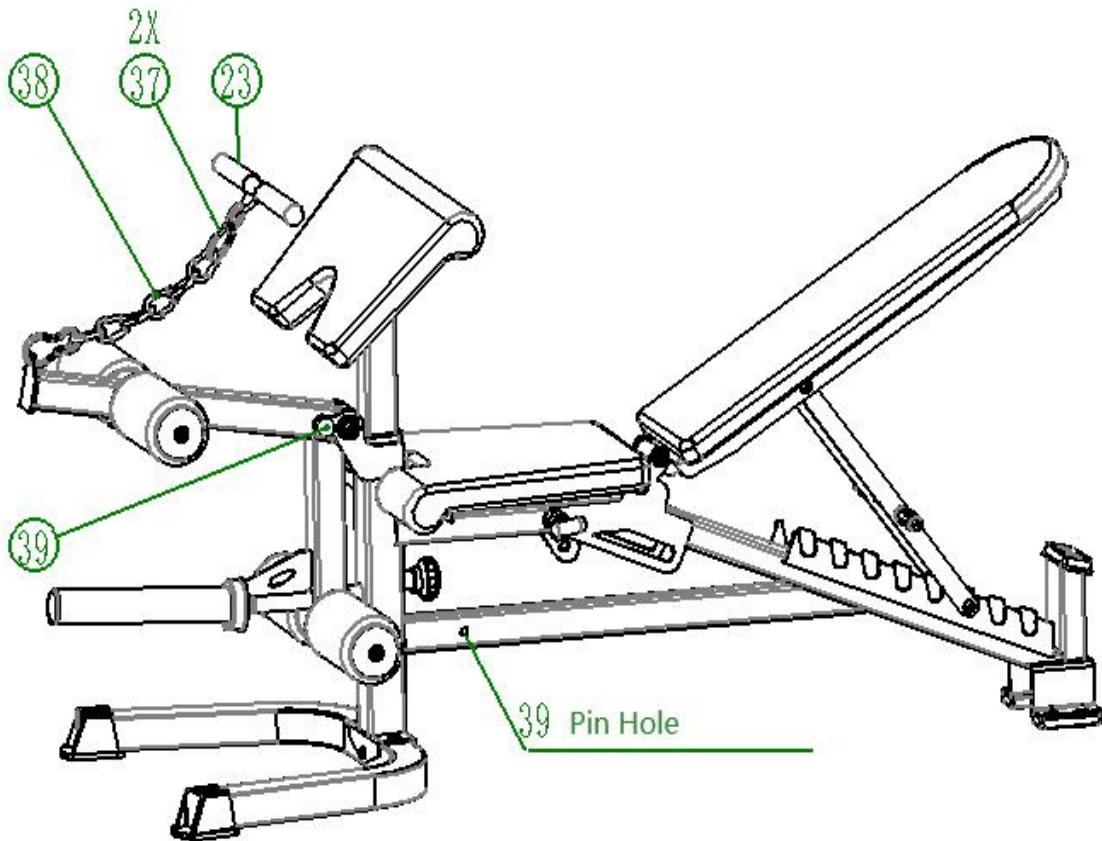

Assembly Instructions

Step No.	Item No.	Name	Quantity	Item No.	Name	Quantity
1						

Tools/Equipment

