

# **FRENCH FITNESS**

## **OWNER'S MANUAL**

**Leg Press / Calf Raise Dual Function**

**FFS-SLP French Fitness FFS Silver Seated Leg Press**

**FFB-SLP French Fitness FFB Black Seated Leg Press (New)**

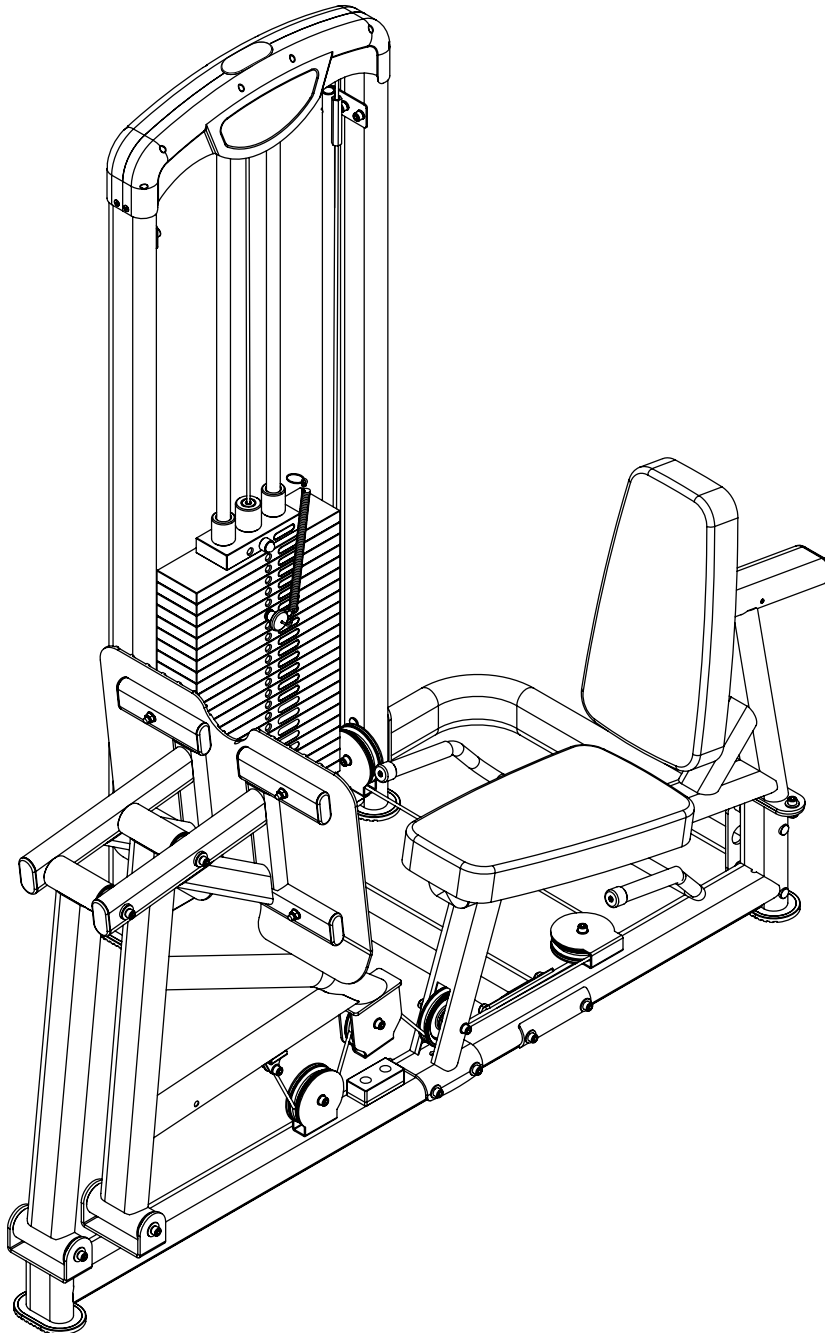

**CAUTION!**

**Read all precautions and instructions in this manual before using this equipment.**

**20220308-V1.0**

# EXPLODED DIAGRAM

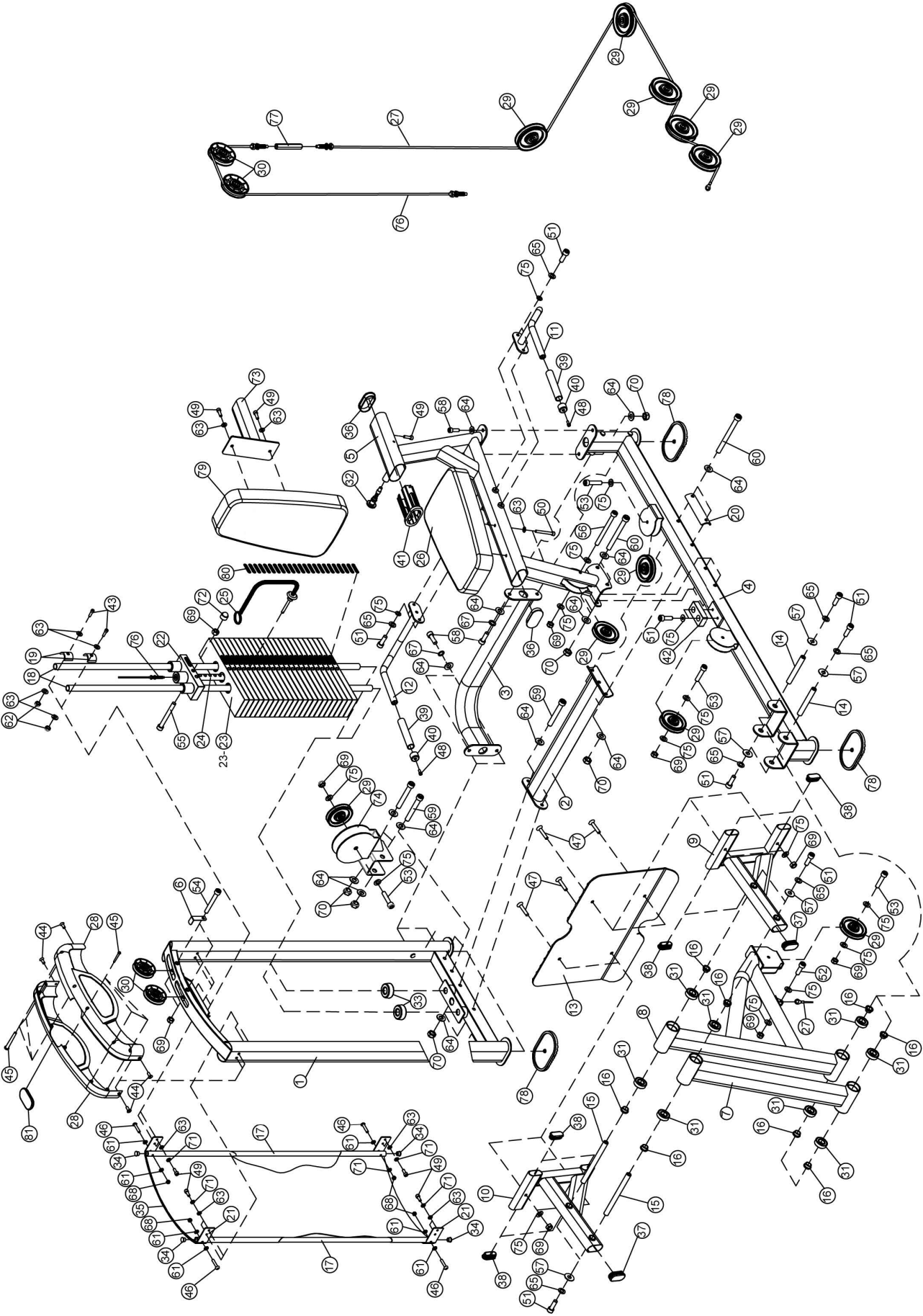

## PARTS LIST LFATLGCR

KEY NO.	PART DESCRIPTION	SPEC	QTY
1	Weight Cage		1
2	Lower Connecting Frame		1
3	Side Connecting Frame		1
4	Stabilizer		1
5	Seat Frame		1
6	L Plate	47×62×20×2	2
7	Front Support Frame		1
8	Back Support Frame		1
9	Left Support Frame		1
10	Right Support Frame		1
11	Left Handle		1
12	Right Handle		1
13	Foot Plate	395×80×650×5	1
14	Lower Axle	Φ20×148	2
15	Upper Axle	Φ20×235	2
16	Bushing	Φ32×Φ25×Φ20.5×14	8
17	Shield Support Rod	Φ19×1.5×1464	2
18	Guide Rod	Φ25×2×1565	2
19	Guide Rod Fixed Base	30×15×R13	2
20	Curved plate	170×52×18×5×R25.5	1
21	Shield Bracket	50×3×539	2
22	Top Weight Plate	189×79×33	1
23	Weight Plate	366×102×25	23
24	Selector Rod	Φ25×675	1
25	Weight Selector Pin		1
26	Seat Pad	550×300×200×70	1
27	Cable 1	L=Φ6×2960	1
28	Top Cap	647×177×56.5	2
29	Pulley	Φ114×Φ10	5
30	Pulley	Φ95×Φ10	2
31	Bearing	6205-2Z	8
32	Quick Release Lock Pin	Φ16×90	1
33	Rubber Bumper	Φ62×Φ24.5×25	2
34	End Cap	Φ19	4
35	Fabric Shield	1440×560	1
36	End Cap	PT50×100	2

## PARTS LIST LFATLGCR

KEY NO.	PART DESCRIPTION	SPEC	QTY
37	End Cap	PT40×80	2
38	End Cap	PT30×70	8
39	Grip	Φ23×150	2
40	Cover Cap	Φ33.5×Φ6.6×25	2
41	Sleeve	PT50×100/PT40×80	1
42	Rubber Bumper	100×50×25	1
43	Hexagon socket button head screws	M8×45	2
44	Philips Screw	M5×10	4
45	Self Tapping Screw	ST4.8×40	6
46	Philips Screw	M6×35	4
47	Socket countersunk head screw	M10×45	4
48	Hexagon socket button head screws	M6×15	2
49	Hexagon socket button head screws	M8×25	11
50	Hexagon socket button head screws	M8×65	2
51	Hexagon socket button head screws	M10×25	14
52	Hexagon socket button head screws	M10×30	1
53	Hexagon socket button head screws	M10×45	4
54	Hexagon socket button head screws	M10×80	2
55	Hexagon socket button head screws	M10×90	1
56	Hexagon socket button head screws	M10×115	1
57	Larger Washer	Φ10×Φ30×2	8
58	Hexagon socket button head screws	M12×30	6
59	Hexagon socket button head screws	M12×70	4
60	Hexagon socket button head screws	M12×130	4
61	Washer	6	8
62	Aircraft Nut	M8	2
63	Washer	8	16
64	Washer	12	24
65	Lock Washers	10	12
67	Lock Washers	12	4
68	Aircraft Nut	M6	4
69	Aircraft Nut	M10	12
70	Aircraft Nut	M12	10
71	Lock Washers	8	8
72	Cover Cap	M10	1
73	Backrest Support Frame		1



## PARTS LIST LFATLGCR

KEY NO.	PART DESCRIPTION	SPEC	QTY
74	Pulley Frame		1
75	Washer	10	21
76	Cable 2	L= (Φ6×1510)	1
77	Connecting Rod	16×100×M12	1
78	End Cap	PT145×95×9	4
79	Backrest Pad	550×300×200×70	1
80	Weight Plate Sticker	51×13	1
81	End Cap	105.5×56×10	1
	Allen Wrench	6#	1
	Allen Wrench	8#	2
	Allen Wrench	10#	1

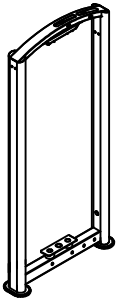

① × 1

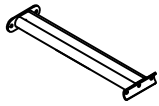

② × 1

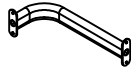

③ × 1

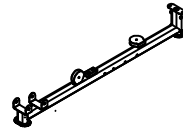

④ × 1

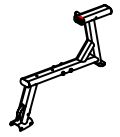

⑤ × 1



⑥ × 2



⑦ × 1

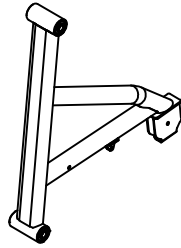

⑧ × 1

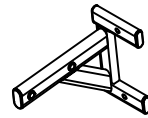

⑨ × 1

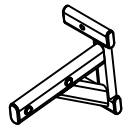

⑩ × 1



⑪ × 1



⑫ × 1

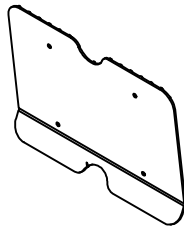

⑬ × 1



⑭ × 2



⑮ × 2



⑰ × 2



⑱ × 2



⑲ × 2



⑳ × 1

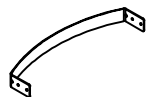

㉑ × 2



22 x 1

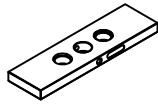

23 x 23



24 x 1



25 x 1



26 x 1

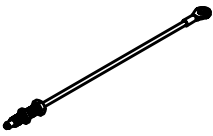

27 x 1

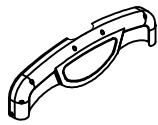

28 x 2



29 x 5



30 x 2



32 x 1



33 x 2

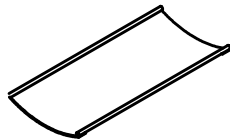

35 x 1



73 x 1



74 x 1



77 x 1



76 x 1



79 x 1

6KG / 13LB	54KG / 120LB	102KG / 224LB
12KG / 26LB	60KG / 133LB	108KG / 238LB
18KG / 39LB	66KG / 146LB	114KG / 251LB
24KG / 52LB	72KG / 159LB	120KG / 264LB
30KG / 65LB	78KG / 172LB	126KG / 277LB
36KG / 78LB	84KG / 185LB	132KG / 291LB
42KG / 91LB	90KG / 198LB	138KG / 304LB
48KG / 104LB	96KG / 211LB	144KG / 317LB

80 x 1



81 x 1

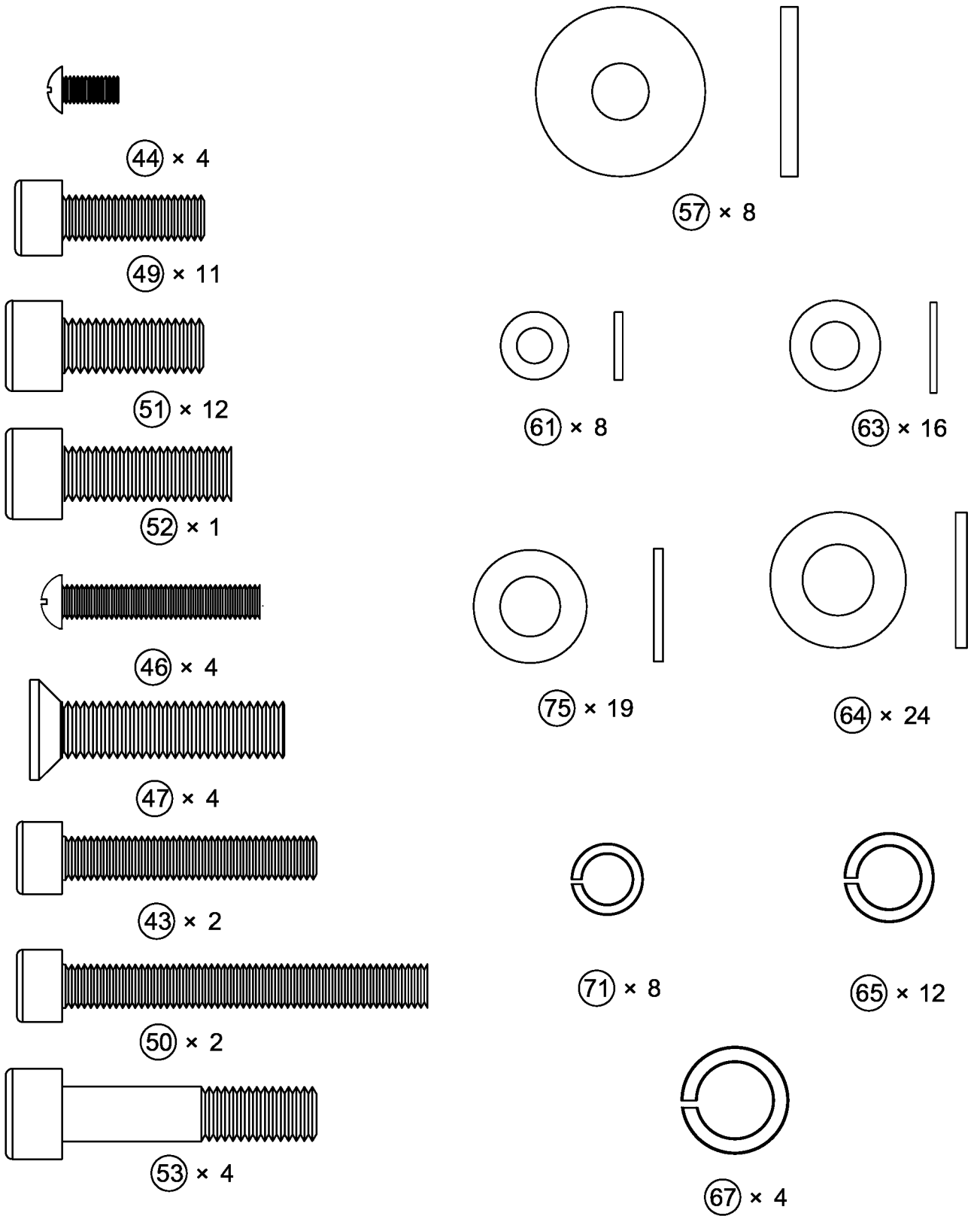

mm

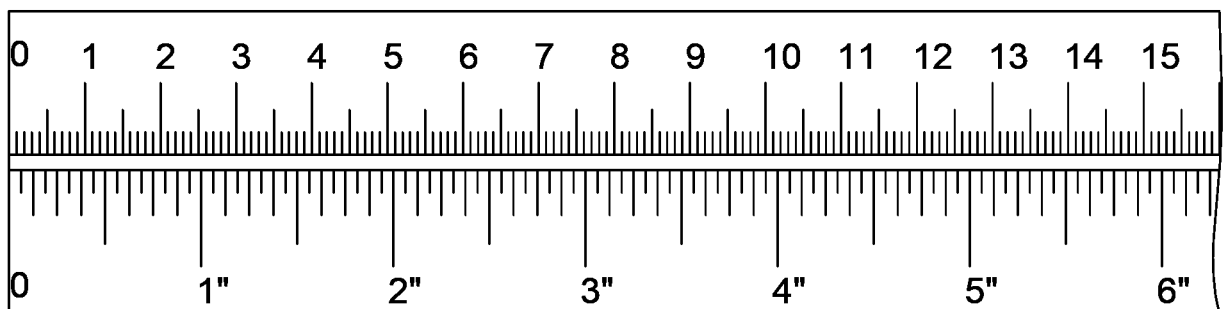

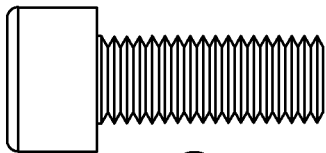

58 × 6



68 × 4

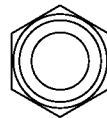

62 × 2

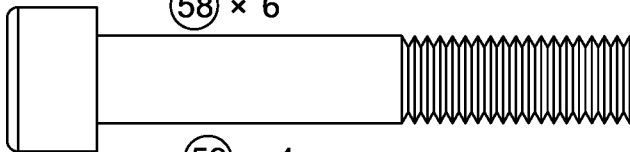

59 × 4

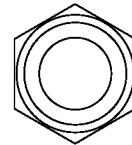

69 × 12

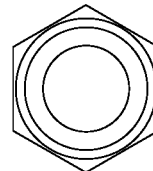

70 × 10

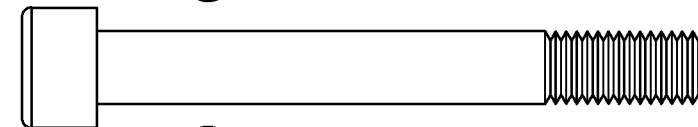

54 × 2

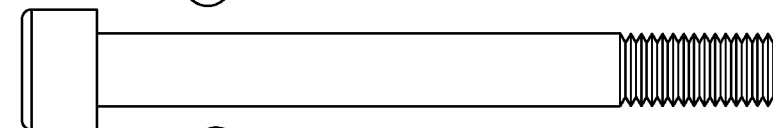

55 × 1

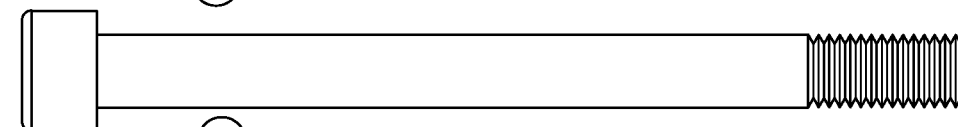

56 × 1

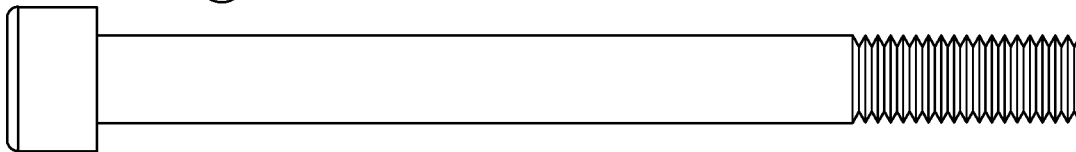

60 × 4

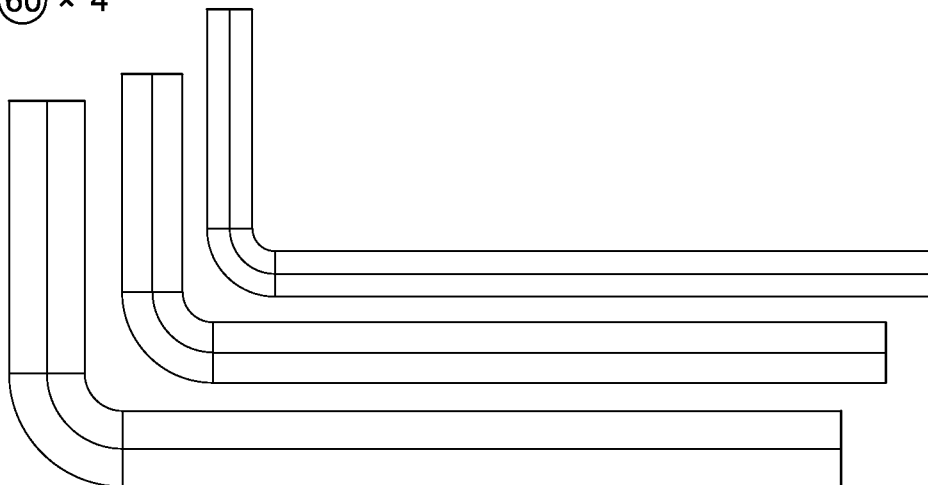





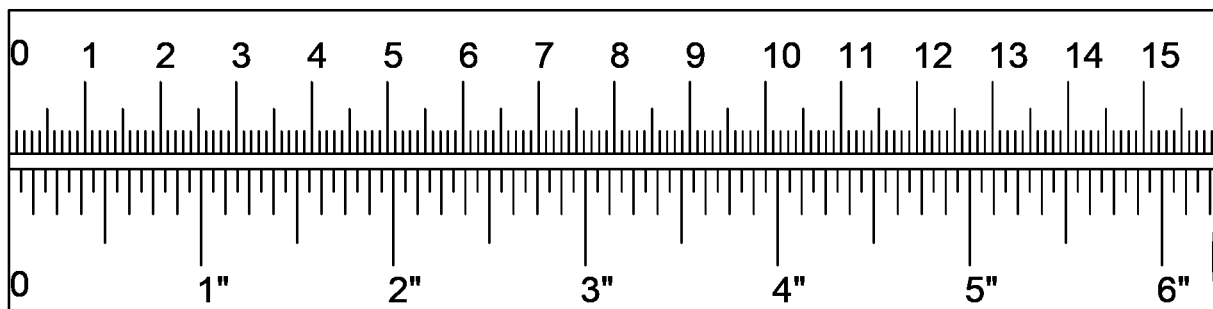

6# × 1

8# × 2

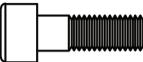
10# × 1

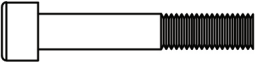
mm

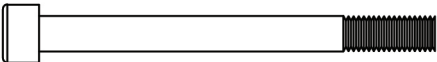

⑤⑧		x4 M12x30	⑥④		x12 Φ12
⑤⑨		x2 M12x70	⑥⑦		x4 Φ12
⑥⑩		x2 M12x130	⑦⑩		x4 M12

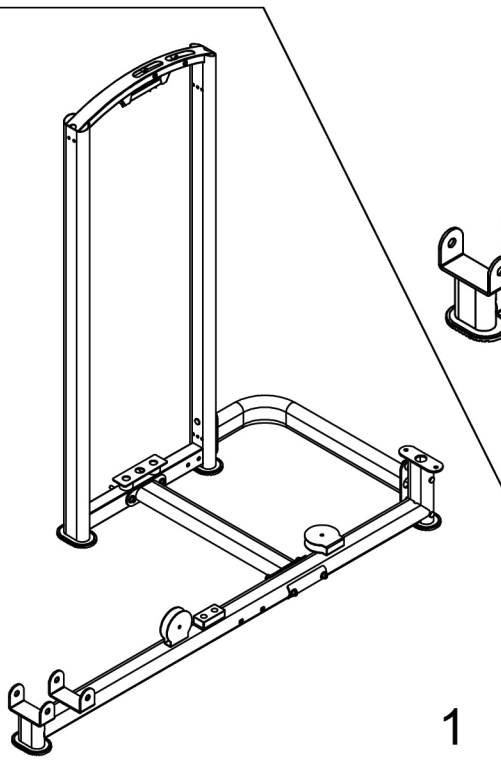
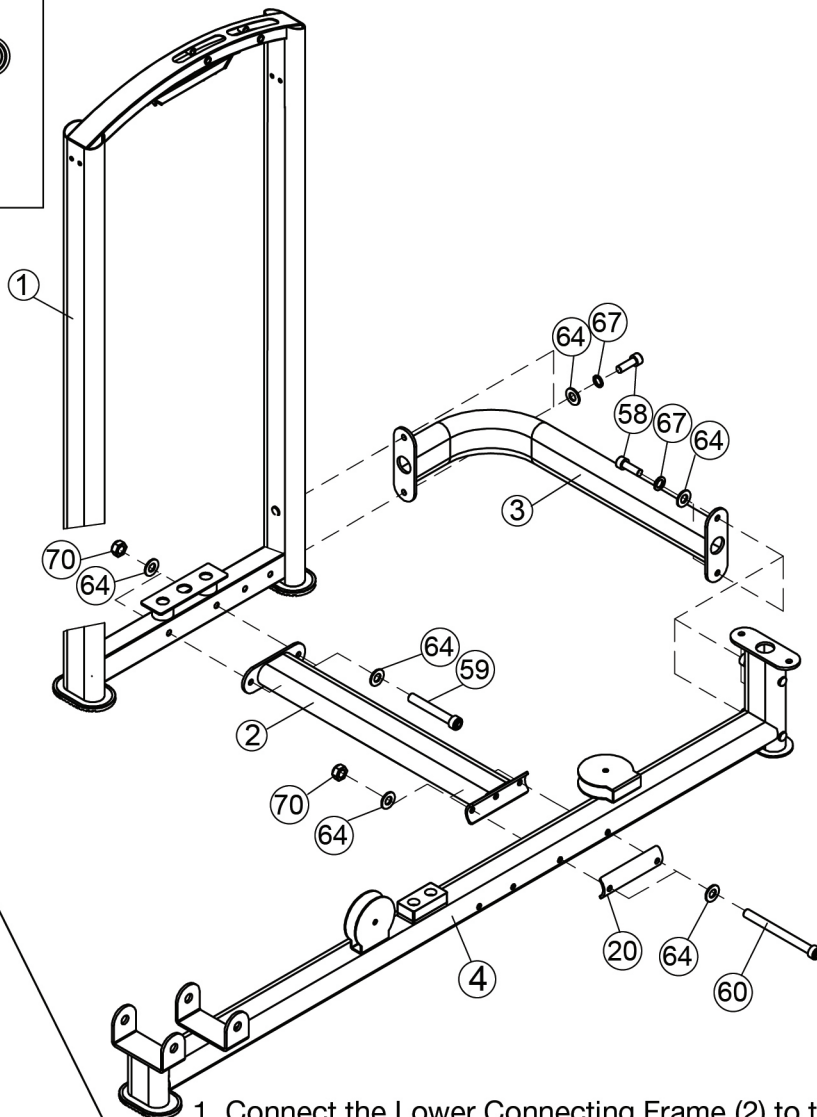
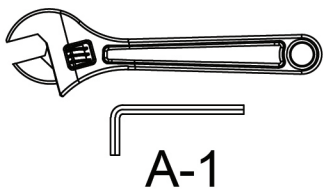

1. Connect the Lower Connecting Frame (2) to the Weight Cage (1) with M12x70 screws (59), washers (64) and M12 nuts (70).

2. Attach the Side Connecting Frame (3) to the Weight Cage (1) with M12x30 screws (58), lock washers (67) and washers (64).

3. Attach the Stabilizer (4) to the Lower Connecting Frame (2) with the Curved Plate (20), M12x130 screws (60), washers (64) and M12 nuts (70).

4. Connect the Stabilizer (4) to the Side Connecting Frame (3) with M12x30 screws (58), lock washers (67) and washers (64).

1

④⑨        ×4    M8×25

⑥③     |    ×4    Φ8

⑤⑨        ×2    M12×70

⑥④     |    ×4    Φ12

⑦⑦        ×2    M12

⑦①     |    ×4    Φ8

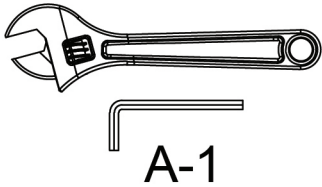

1. Attach the Shield Bracket (21) to the Weight Cage (1) with M8x25 screw (49), lock washer (71) and washer (63).

2. Connect the Pulley Frame (74) to the Weight Cage (1) with M12x70 screw (59), washer (64) and aircraft nut M12 (70).

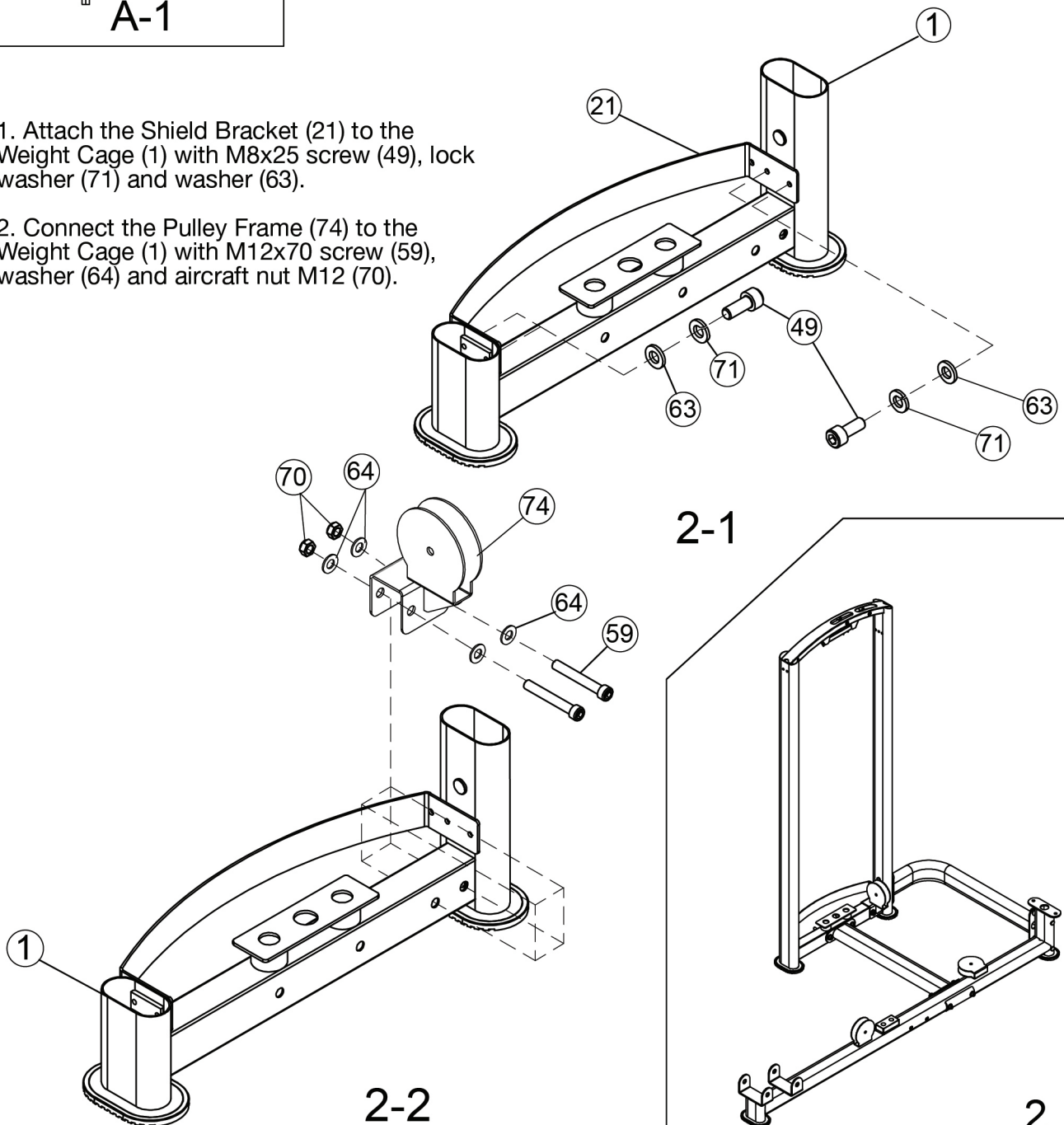

46  ×4 M6×35

63  | ×4 Φ8

49  ×4 M8×25

71  | ×4 Φ8

61  | ×8 Φ6

68  | ×4 M6

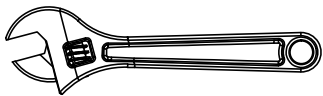

A-1

A → B → C → D

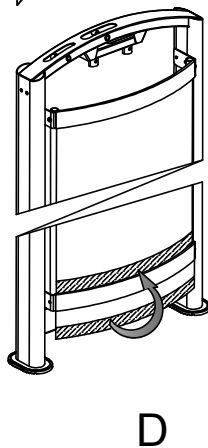
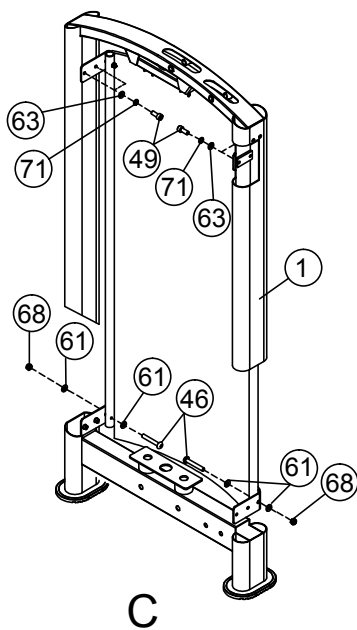
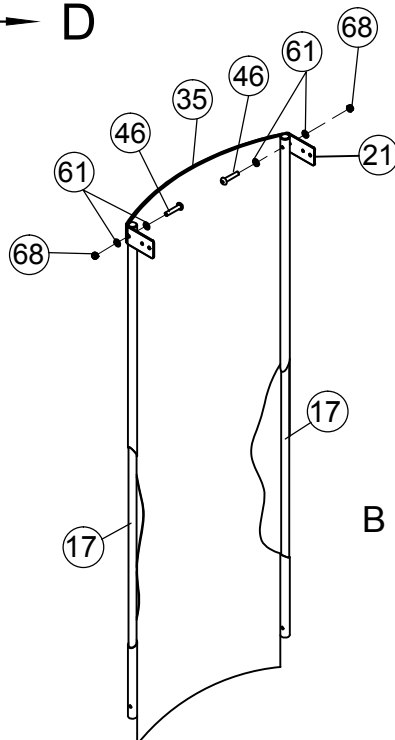
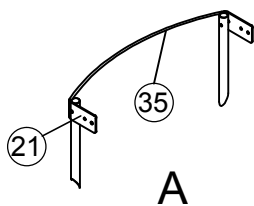

1. Attach the Shield Bracket (21) to the Fabric Shield (35).

2. Insert the Shield Support Rod (17) to the Fabric Shield (35) and secure with M6x35 screw (46), washer (61) and aircraft nut M6 (68).

3. Attach Fabric Shield (35) to the Weight Cage (1)

4. Secure top part with M8x25 screw (49), lock washers (71) and washer (63).

5. Secure lower part with M6x35 screw (46), washer (61) and aircraft nut (68).

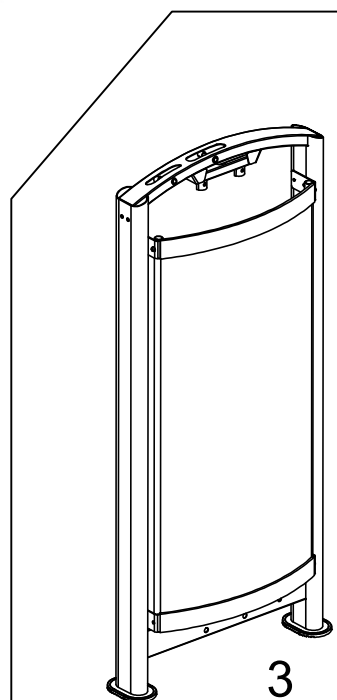



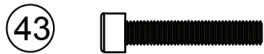

×2 M8×45



×2 M8

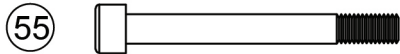

×1 M10×90



×4 Φ8



×1 M10

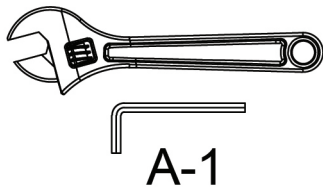

1. Insert the ends of the Guide Rod (18) into the holes of the Weight Cage (1).
2. Slide the Rubber Bumper (33) on to each Guide Rod (18).
3. Ensuring the right connection, insert the Weight Plates (23) onto the Guide Rod (18). Attach the Weight plate Sticker (80) onto the Weight Plates (23).

4. Insert the Selector Rod (24) into the central hole of a Weight Plates (23). Insert the Weight Selector Pin (25) through a weight, into the Selector Rod (24).

5. Slide the Top Weight Plate (22) onto the Guide Rod (18). Secure with M10x90 screw (55), aircraft nut (69) and cover cap (72).

6. Attach the Guide Rod (18) to the Weight Cage (1) together with the Guide Rod Fixed Base (19). Secure with M8x45 screw (43), washer (63) and aircraft nut (62).

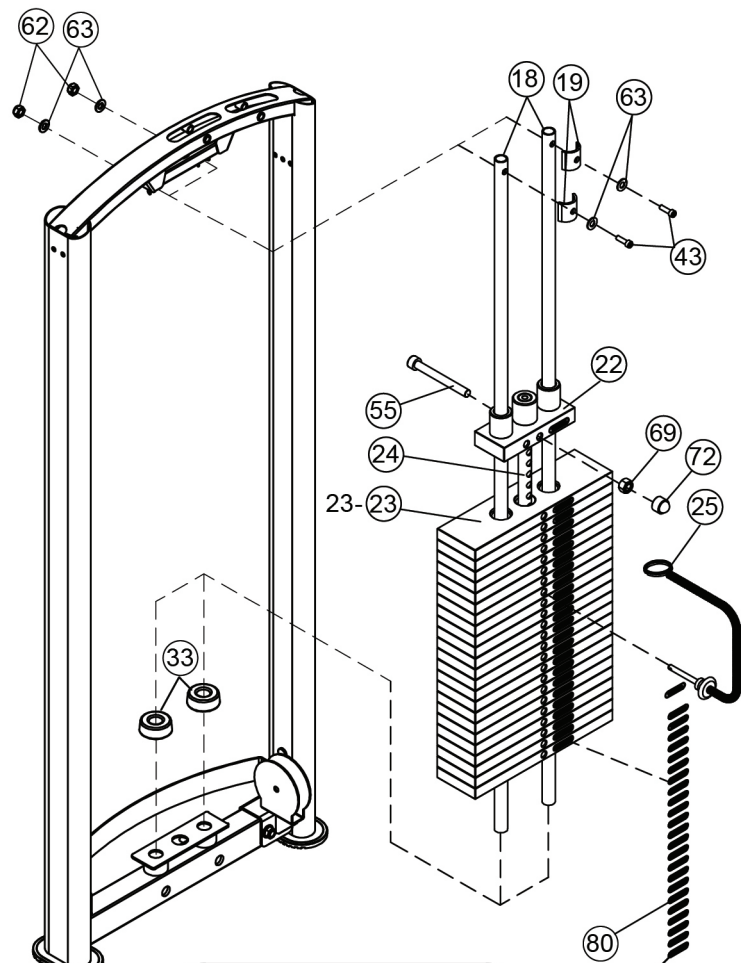

6KG / 13LB

144KG / 317LB

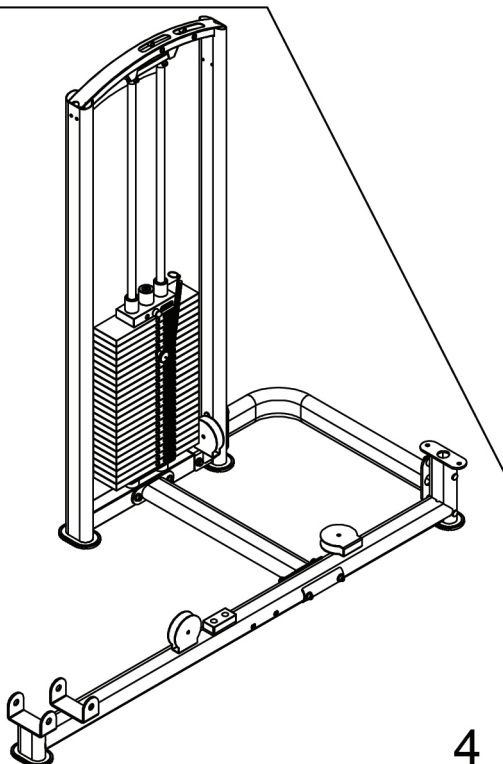

4



x4 M10x45



x8 Φ10



x8 M10x25



x4 M10

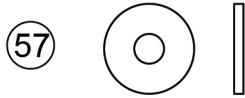

x8 Φ10 x Φ30



x4 Φ10

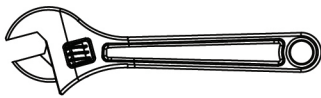

A-1

1. Attach the Front Support Frame (7) to the Stabilizer (4). Insert the Lower Axle (14) through the Stabilizer (4) and Front Support Frame (7). Secure with M10x25 screw (51), washer (65) and large washer (57).

2. Attach the Back Support Frame (8) to the Stabilizer (4). Insert the Lower Axle (14) through the Stabilizer (4) and Back Support Frame (8). Secure with M10x25 screw (51), washer (65) and large washer (57).

3. Insert the Upper Axle (15) through the Front Support Frame (7) and Back Support Frame (8).

4. Attach the Right Support Frame (10) to the Front Support Frame (7) and Back Support Frame (8). Secure with M10x25 screw (51), washer (65) and large washer (57).

5. Attach the Left Support Frame (9) to the Front Support Frame (7) and Back Support Frame (8). Secure with M10x45 screw (47), washer (75) and aircraft nut (69).

6. Attach the Foot Plate (13) to the Left Support Frame (9) and Right Support Frame (10). Secure with M10x45 screw (47), washer (75) and aircraft nut (69).

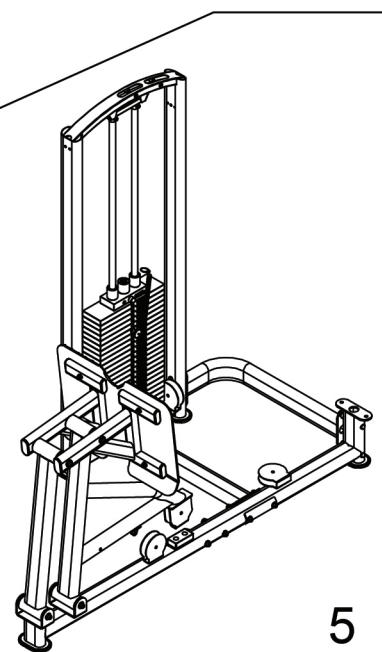
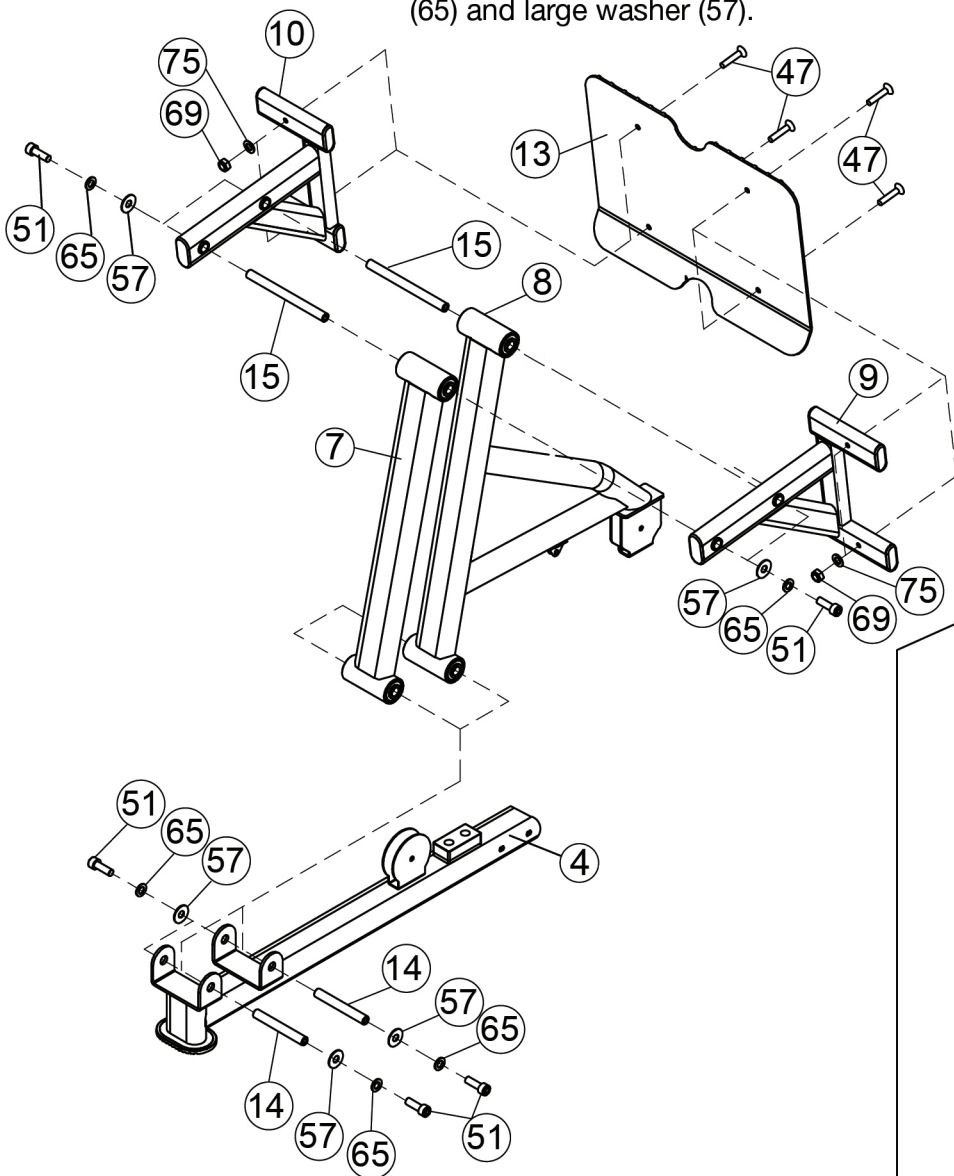



x4 M10x25



x8  $\Phi$ 12

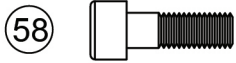

x2 M12x30



x4  $\Phi$ 10



x4 M12



x4  $\Phi$ 10

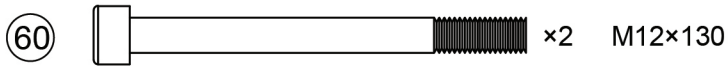

x2 M12x130

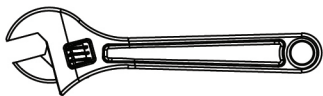

A-1

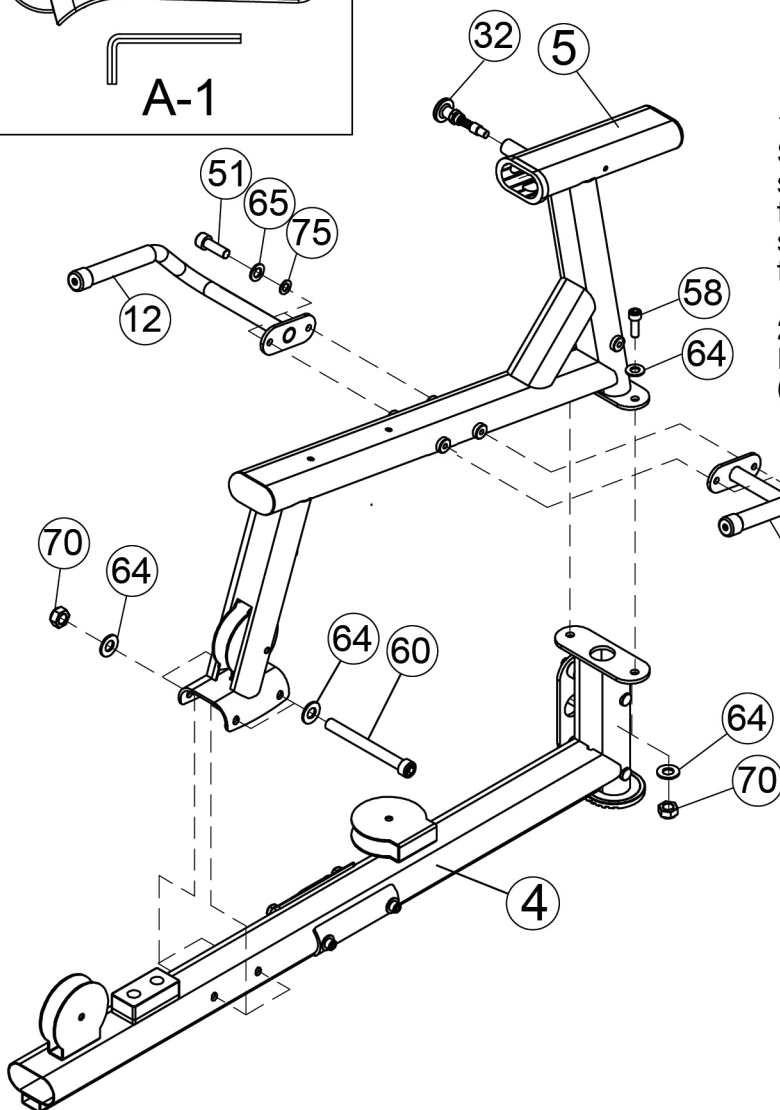

1. Attach the Seat Frame (5) to the Stabilizer (4). Secure with M12x130 screw (60), washer (64), aircraft nut (70) for the seat pad portion and M12x30 screw (58), washer (64), aircraft nut (70) for the backrest pad portion.

2. Attach the Handle (12) to the Seat Frame (5). Secure with M10x25 screw (51), washer (65) and washer (75).

3. Attach the Handle (11) to the Seat Frame (5). Secure with M10x25 screw (51), washer (65) and washer (75).

4. Insert the Quick Release Lock Pin (32) onto the Seat Frame (5).

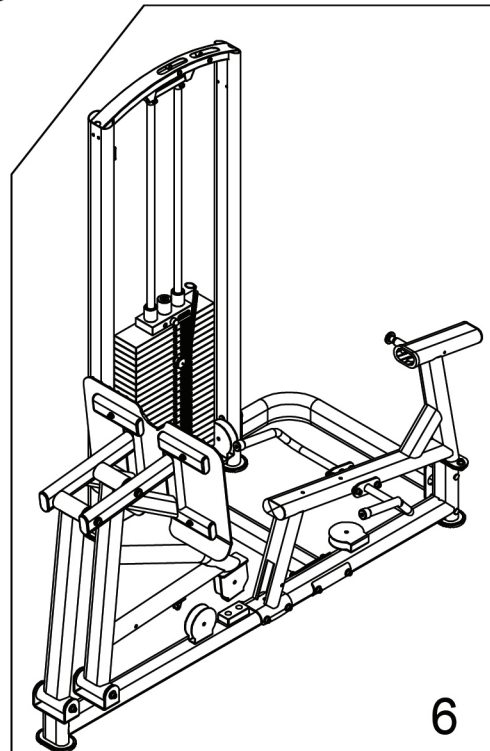

6

49



x3 M8x25

63



x4 Φ8

50

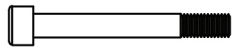

x2 M8x65

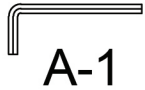

1. Attach the Seat Pad (26) to the Seat Frame (5). Secure with M8x65 screw (50) and washer (63).

2. Attach the Backrest Pad (79) to the Backrest Pad Support Frame (73). Secure with M8x25 screw (49) and washer (63).

3. Insert the Backrest Pad (73) on to the Seat Frame (5). Secure with M8x25 screw (49).

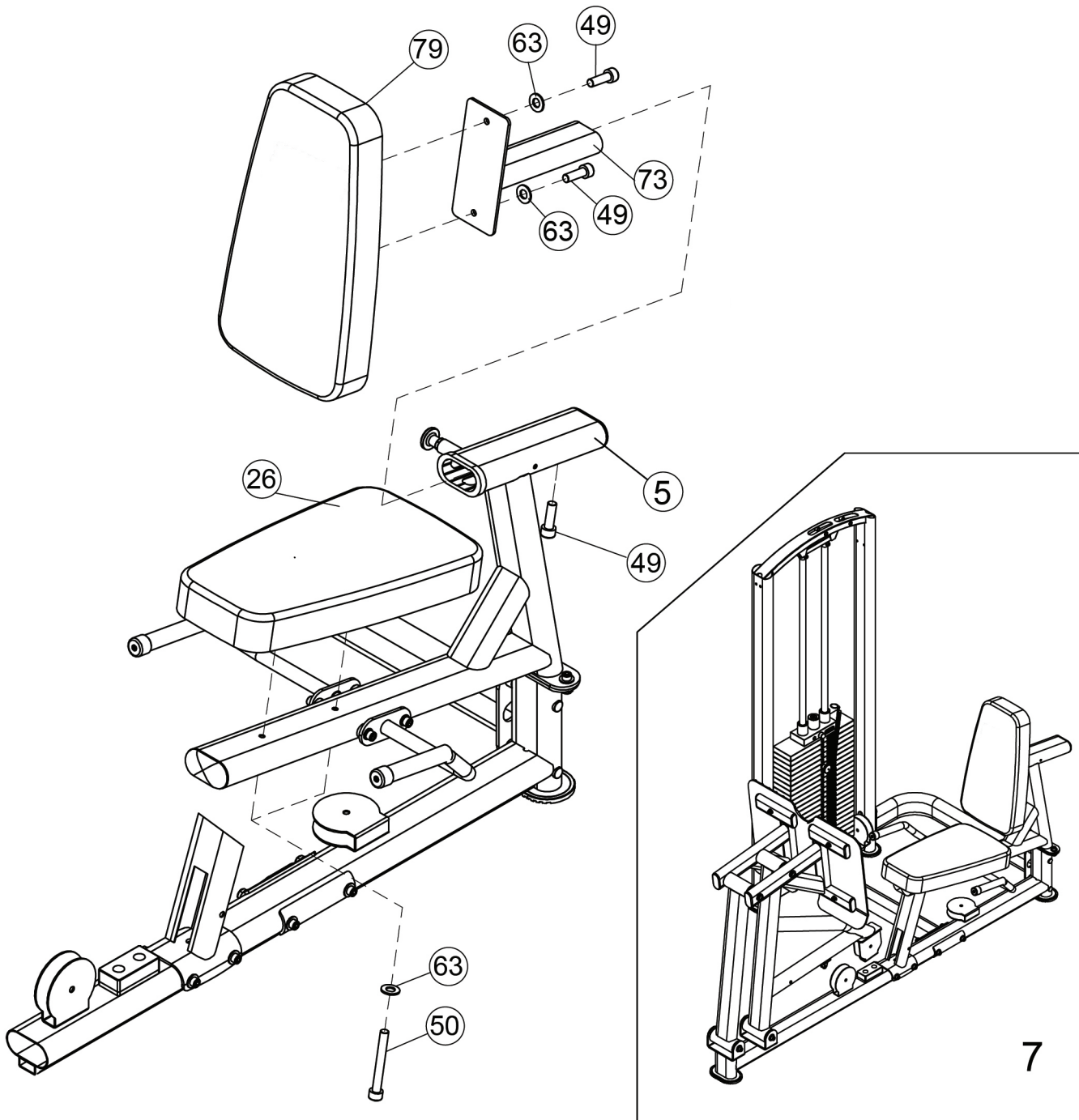



52		x1	M10x30	53		x4	M10x45
54		x2	M10x80	75		x11	Φ10
56		x1	M10x115	69		x7	M10
44		x4	M5x10				

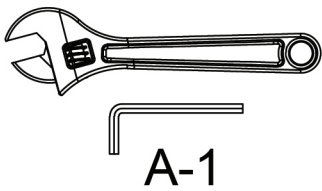

1. Position the end of the Cable 1 (27) underneath the 1st Pulley (29) which is attached on the Stabilizer (4). Secure the end of the Cable 1 (27) with M10x30 screw (52), washer (75) and aircraft nut (69).
2. Draw the cable upward through the 2nd Pulley (29) attached on the Back Support Frame (8). Secure with M10x45 screw (53), washer (75) and aircraft nut (69).
3. Draw the cable downward through the 3rd Pulley (29). Secure with M10x115 screw (56), washer (75) and aircraft nut (69).

4. Draw the cable around the 4th Pulley (29) going to the right. Secure with M10x45 screw (53) and washer (75).
5. Draw the cable underneath the 5th Pulley (29). Secure with M10x45 screw (53), washer (75) and aircraft nut (69).
6. Position the Cable 2 (76) on the Weighy Cage (1).

7. Draw Cable 2 (76) upward, positioned above the 2 x Pulleys (30). Secure both pulleys with the L Plate (6) using M10x80 screw (54) and aircraft nut (69).

8. Connect the Cable 2 (76) to the Connecting Rod (77) and the Cable 1 (27) together.

9. Once the cables and pulleys are secured, secure the Top Cap (28) with M5x10 screw (44).

