

FRENCH FITNESS

FF-PLHSLP

FRENCH FITNESS P/L HACK SQUAT
LEG PRESS COMBO

ASSEMBLY AND EXERCISE MANUAL

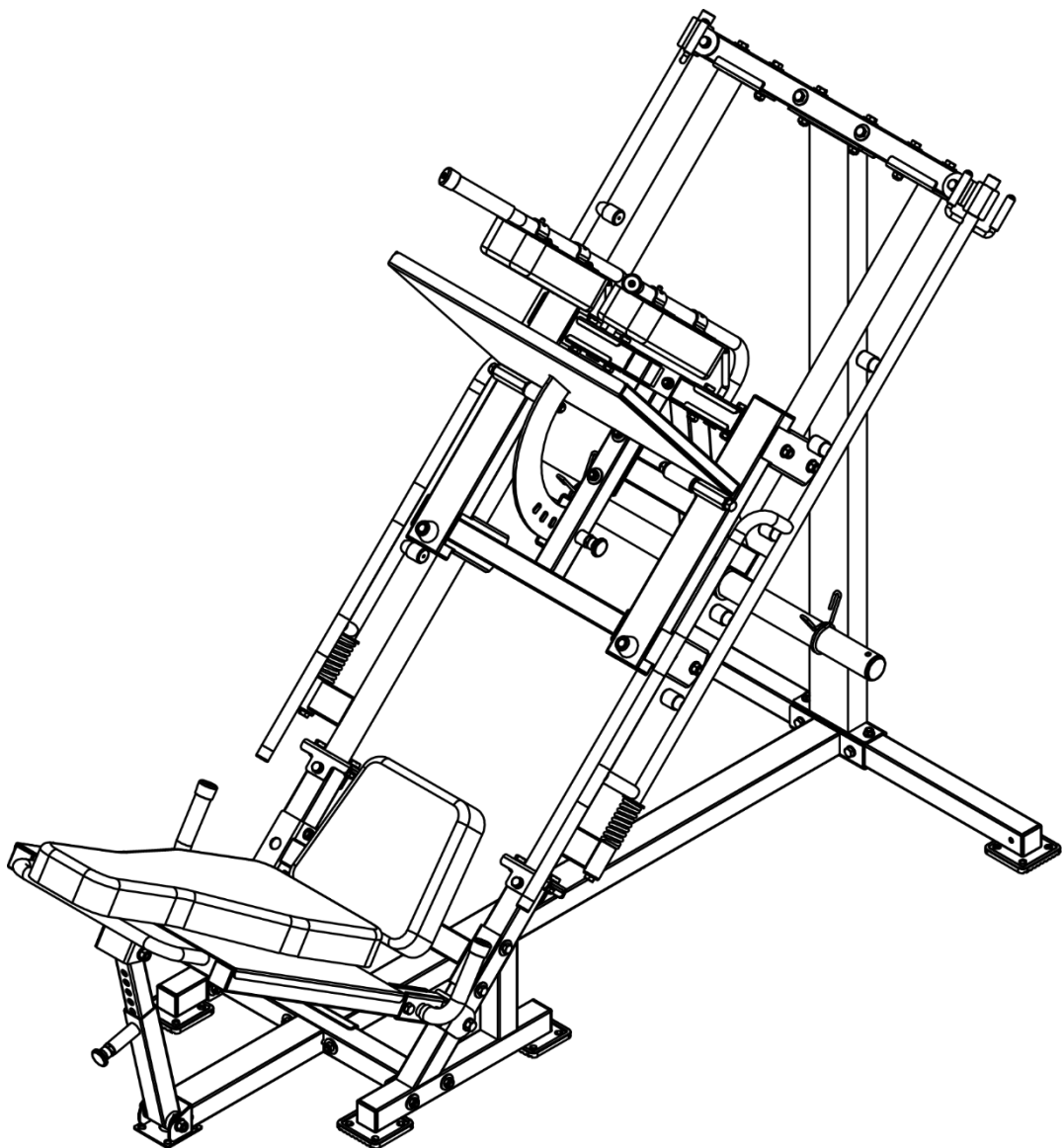

FEATURES

- Adjustable platform: the height of the seat can be adjusted by pulling the pin shaft can be correctly positioned in this exercise
- Dual-purpose back pad: can be fixed in the squat and leg press positions
- Multi-position locking: suitable for squats and leg press exercises

TECH SPECS

- Steel Tubing: 50mm x 70mm x 2.5mm
- 12 Gauge Steel
- Product Weight: 320 lbs
- Maximum Load Capacity (Total Lbs of Loaded Weight Plates): 555 lbs
- Maximum user weight: 350 lbs
- User Height Range: 4' 10" to 6' 7"
- Hack Squat Plate Dimensions: 22.5" wide x 20.5" depth
- Leg Press Plate Dimensions: 23.5" wide x 18.75" depth
- 5 position adjustments on Leg Press Plate
- 8 position adjustments on Hack Squat Plate
- Weight Horn Thickness: 50.35mm (Fits all French Fitness Olympic Plates - but Please verify if you are using your own that yours are at least 50.5mm large)
- Maximum Distance from the footplate to the seat (Leg Press Setting) : 70.8" (1800mm)
- Maximum Distance from the shoulder pads to the footplate (Hack Squat setting): 67.3" (1710mm)
- Dimensions: 87"L x 43"W x 70"H (L:2210mm, W:1070mm, H:1770mm)

SHIPPING DIMS & WEIGHT

- Box 1 of 4: 62"L x 19"W x 6"H, 74lbs
- Box 2 of 4: 66.5"L x 18"W x 4"H, 88lbs
- Box 3 of 4: 29"L x 27"W x 8.5"H, 77lbs
- Box 4 of 4: 36"L x 26"W x 5"H, 79lbs

WARRANTY

10 Years Part, 1 Year Labor (Light Commercial)

TABLE OF CONTENTS

BEFORE YOU BEGIN.....	2
IMPORTANT SAFETY NOTICES	3
HARDWARE PACK	4
ASSEMBLY INSTRUCTIONS	8
EXPLODED DIAGRAM	19
PARTS LIST	20
EXERCISES	22

BEFORE YOU BEGIN

Thank you for selecting the FF-PLHSLP. For your safety and benefit, read this manual carefully before using the machine. As a manufacturer, we are committed to provide you complete customer satisfaction

IMPORTANT SAFETY NOTICE

PRECAUTIONS

This exercise machine is built for optimum safety. However, certain precautions apply whenever you operate a piece of exercise equipment. Be sure to read the entire manual before you assemble or operate your machine. In particular, note the following safety precautions:

1. **Keep children and pets away from the machine at all times. DO NOT leave children unattended in the same room with the machine.**
2. Only one person at a time should use the machine.
3. If the user experiences dizziness, nausea, chest pain, or any other abnormal symptoms, STOP the workout at once. CONSULT A PHYSICIAN IMMEDIATELY.
4. Position the machine on a clear, leveled surface. DO NOT use the machine near water or outdoors.
5. Keep hands away from all moving parts.
6. Always wear appropriate workout clothing when exercising. DO NOT wear robes or other clothing that could become caught in the machine. Running or aerobic shoes are also required when using the machine.
7. Use the machine only for its intended use as described in this manual. DO NOT use attachments not recommended by the manufacturer.
8. Do not place any sharp object around the machine.
9. Disabled person should not use the machine without a qualified person or physician in attendance.
10. Before using the machine to exercise, always do stretching exercises to properly warm up.
11. Never operate the machine if the machine is not functioning properly.
12. Max Drop Weight: 250 kg

WARNING: BEFORE BEGINNING ANY EXERCISE PROGRAM, CONSULT YOUR PHYSICIAN. THIS IS ESPECIALLY IMPORTANT FOR INDIVIDUALS OVER THE AGE OF 35 OR PERSONS WITH PRE-EXISTING HEALTH PROBLEMS. READ ALL INSTRUCTIONS BEFORE USING ANY FITNESS EQUIPMENT. WE ASSUME NO RESPONSIBILITY FOR PERSONAL INJURY OR PROPERTY DAMAGE SUSTAINED BY OR THROUGH THE USE OF THIS PRODUCT.

SAVE THESE INSTRUCTIONS.

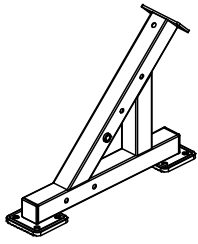

① × 2

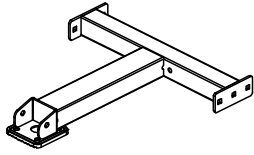

② × 1

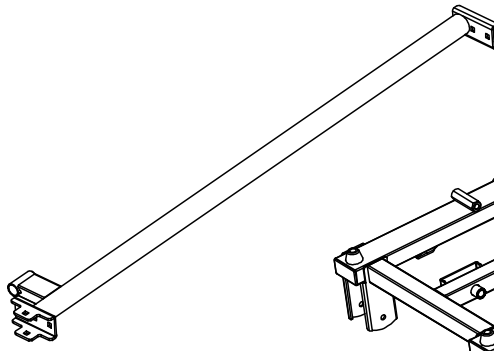

③ × 2

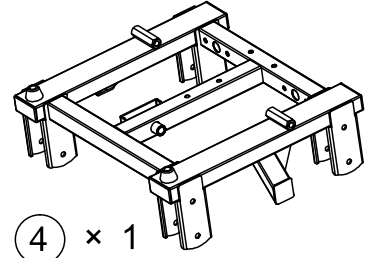

④ × 1

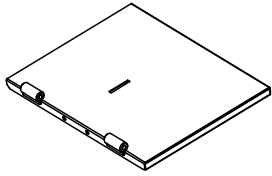

⑤ × 1

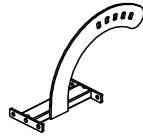

⑥ × 1

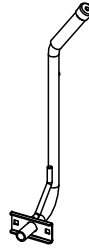

⑦ × 1

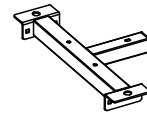

⑧ × 1

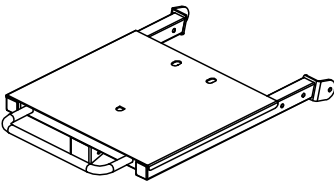

⑨ × 1

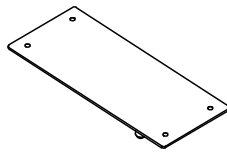

⑩ × 1



⑪ × 1

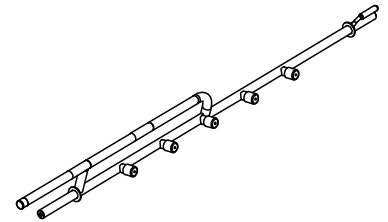

⑫ × 1

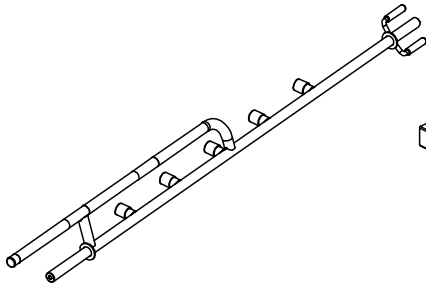

⑬ × 1

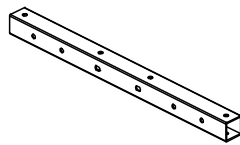

⑭ × 1

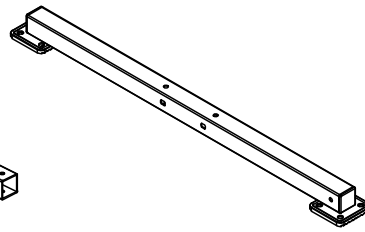

⑮ × 1

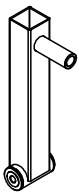

⑰ × 1

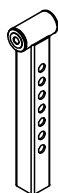

⑱ × 1

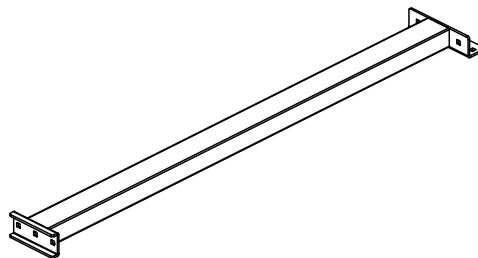

⑲ × 1

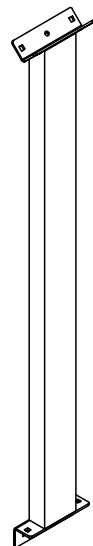

⑯ × 1

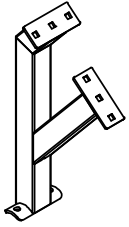

20 × 1

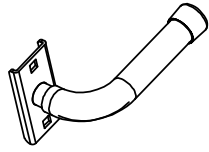

21 × 2



22 × 2

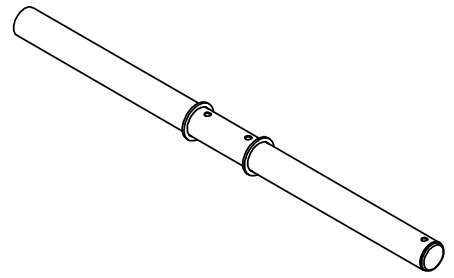

23 × 1

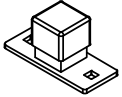

24 × 1



25 × 4

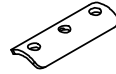

26 × 1

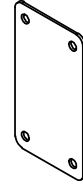

28 × 2



29 × 4

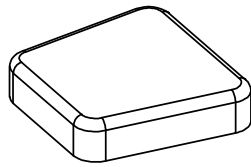

31 × 1

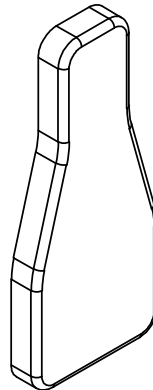

32 × 1

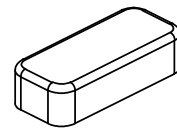

33 × 2



34 × 8



35 × 2



36 × 2



37 × 2

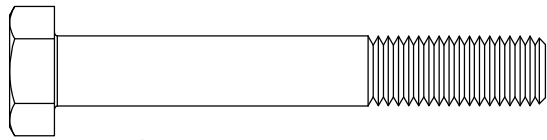

⑤0 × 24

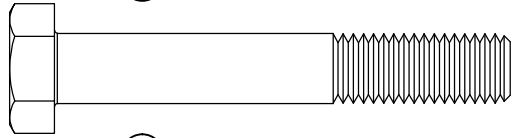

⑤1 × 8

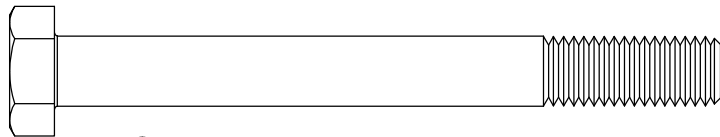

⑤2 × 2

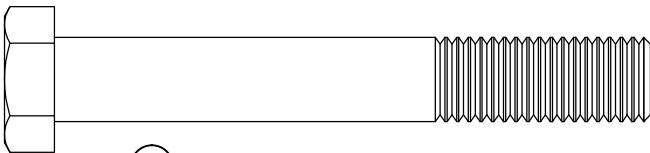

⑤3 × 2

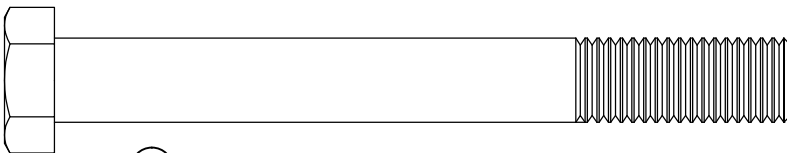

⑤5 × 8

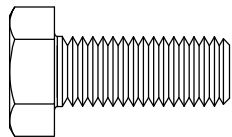

⑤6 × 6

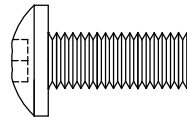

⑤7 × 8

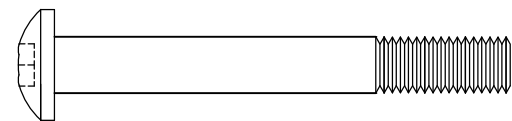

⑤8 × 3

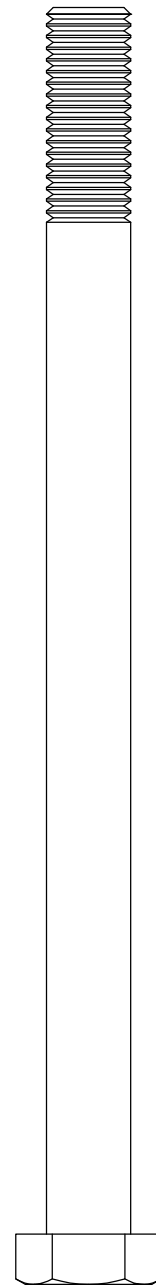

⑤4 × 2

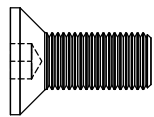

⑤9 × 4



⑥0 × 2

mm



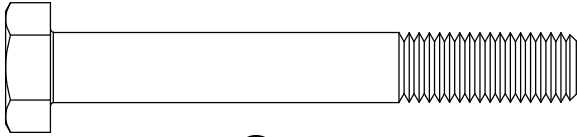

⑥1 ×10

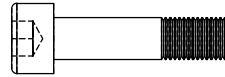

⑥2 ×1

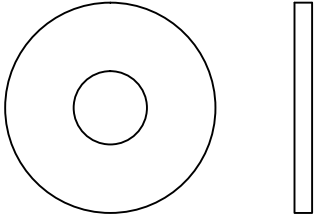

⑥3 ×22

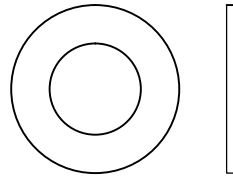

⑥6 ×24

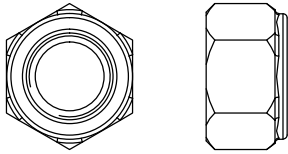

⑥4 ×12

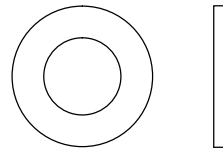

⑥7 ×76

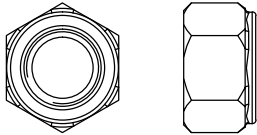

⑥5 ×48

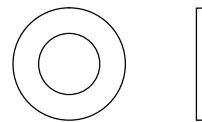





⑥8 ×11

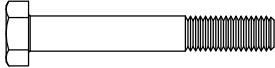

5#×1

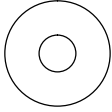

- | | | | | | | | | | |
|----|---|----|-----------|-----------|---|---|---|-----------|-----|
| ⑤0 |  | ×6 | M10× 70mm | ⑥7 |  | × | 6 | Φ20×Φ10.5 | |
| ⑥3 |  | × | 6 | Φ30×Φ10.5 | ⑥5 |  | × | 6 | M10 |

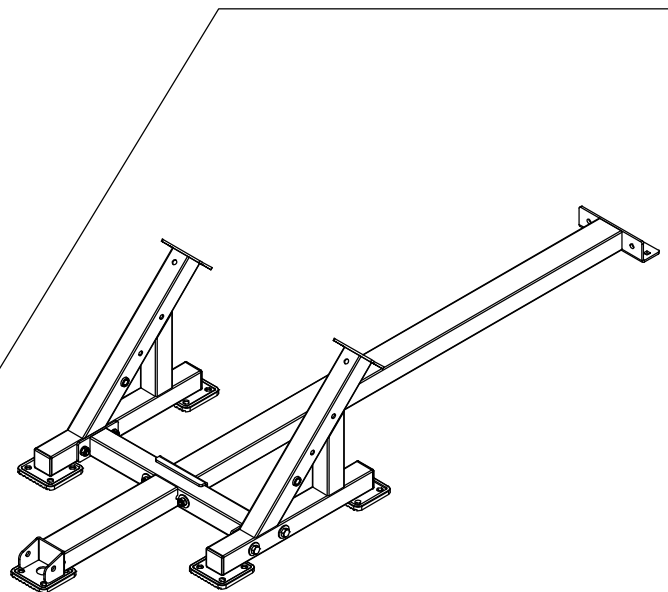
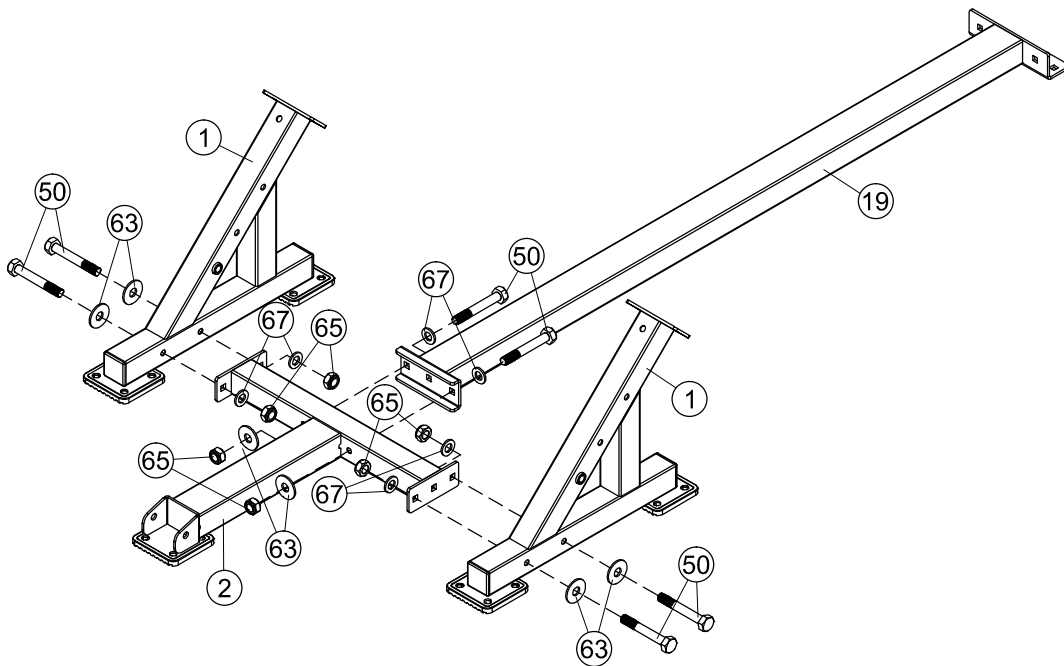
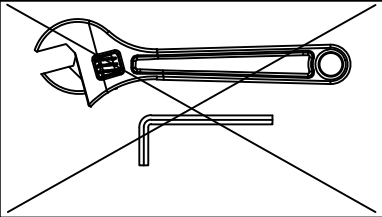

1

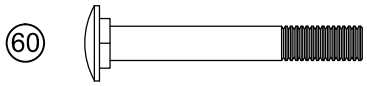

60

×2 M10× 75mm

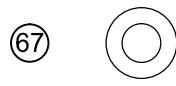

67

×6 Φ20×Φ10.5

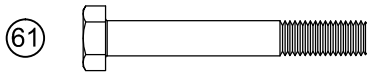

61

×2 M10× 75mm







65

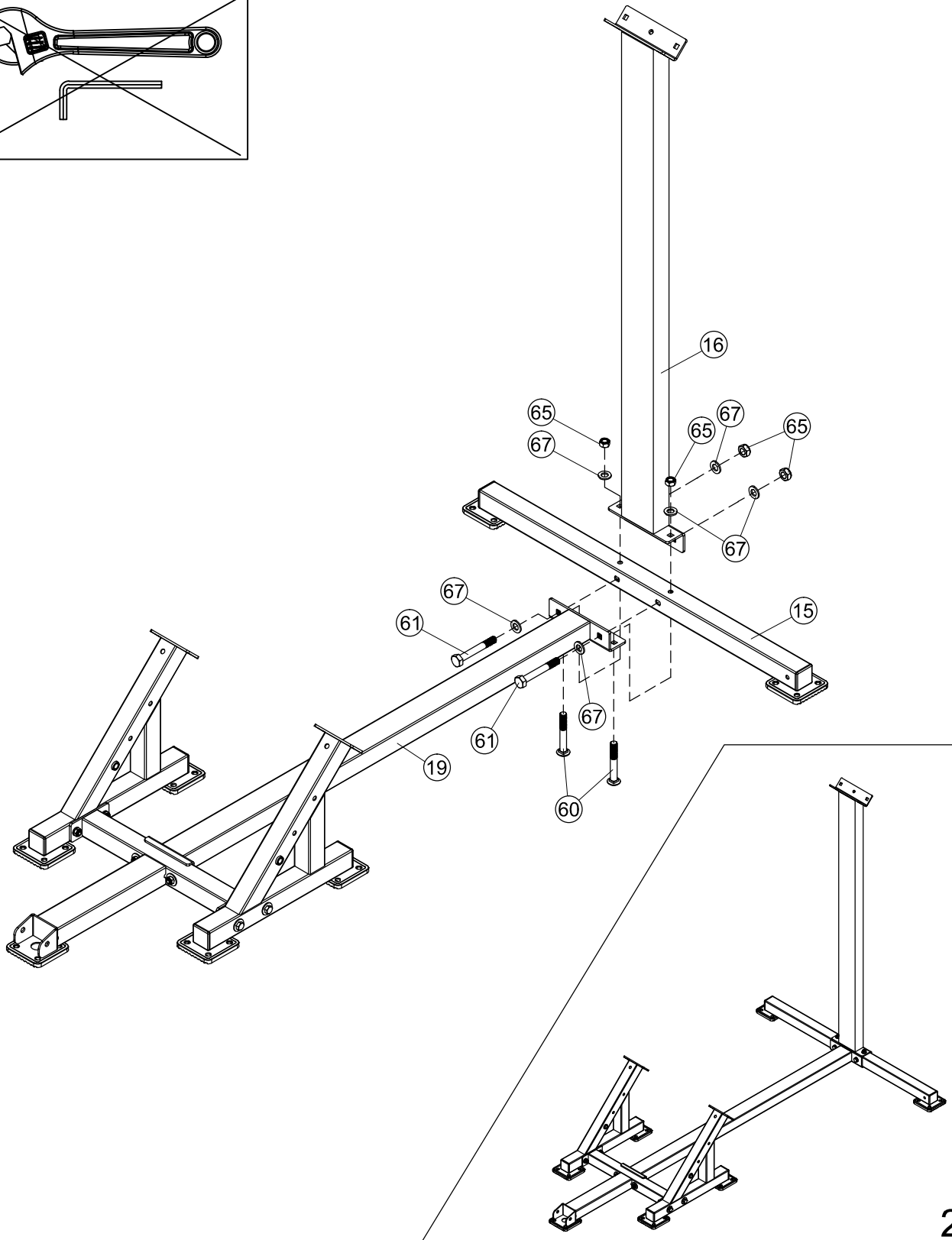
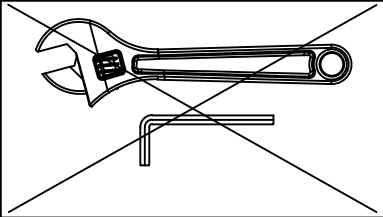

×4 M10

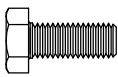

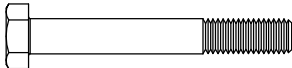

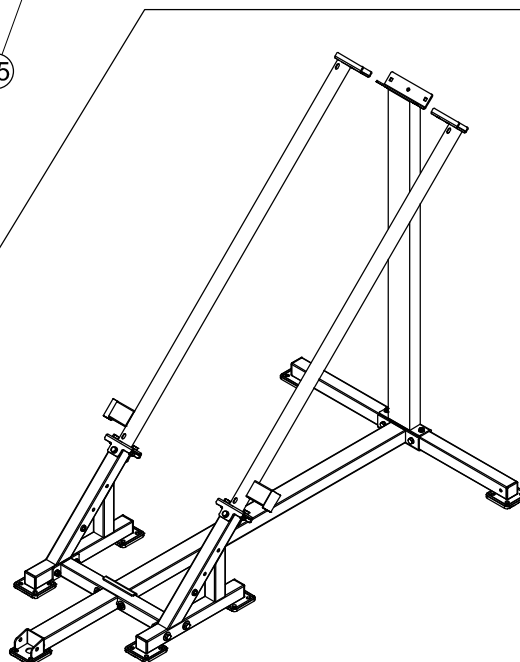
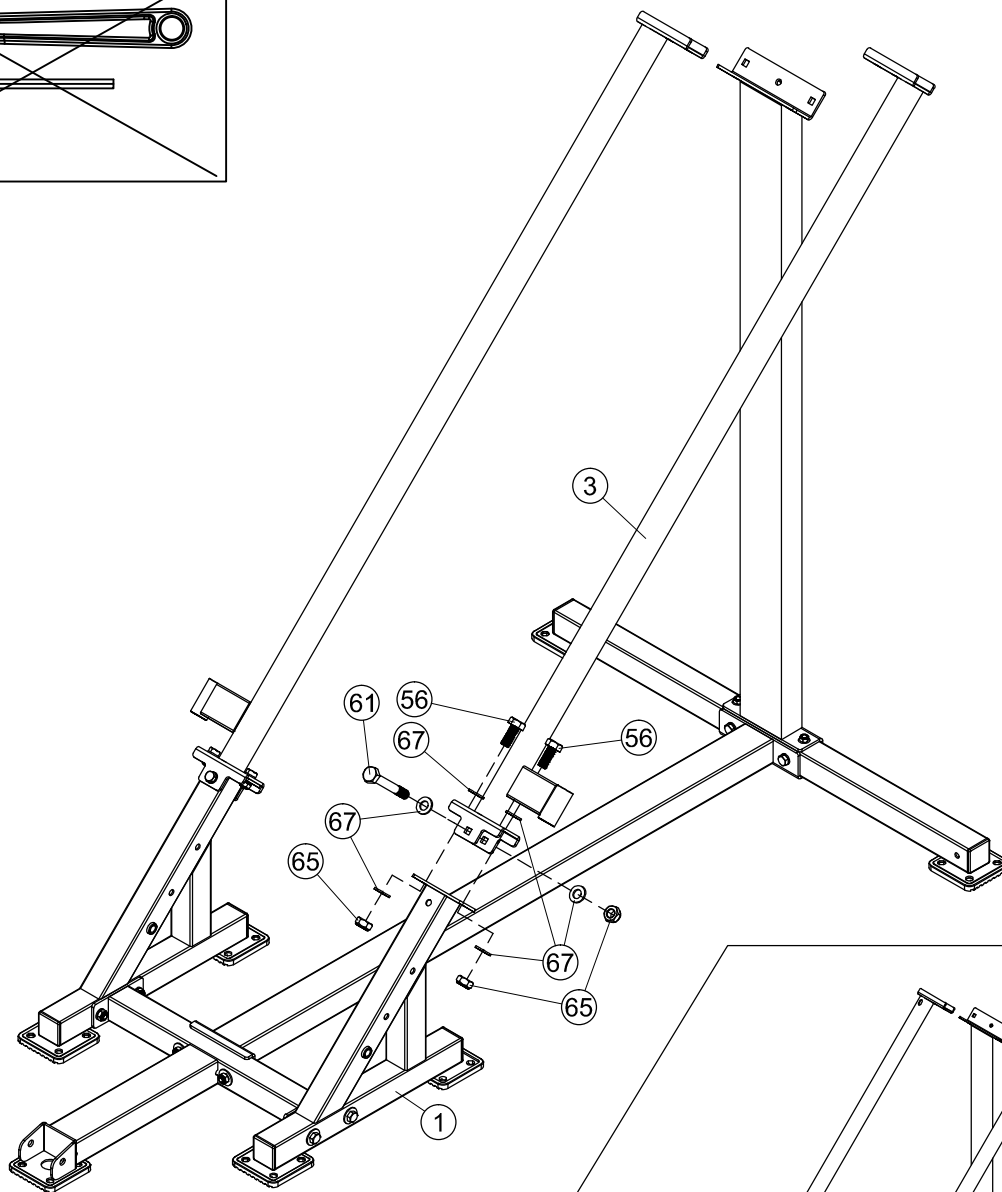
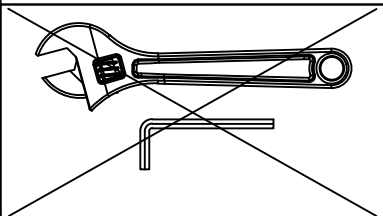

2



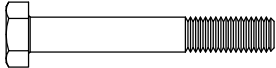

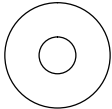
- | | | | | | | | |
|----|---|----|-----------|----|---|-----|-----------|
| ⑤6 |  | ×4 | M10× 25mm | ⑥7 |  | ×12 | Φ20×Φ10.5 |
| ⑥1 |  | ×2 | M10× 75mm | ⑥5 |  | ×6 | M10 |

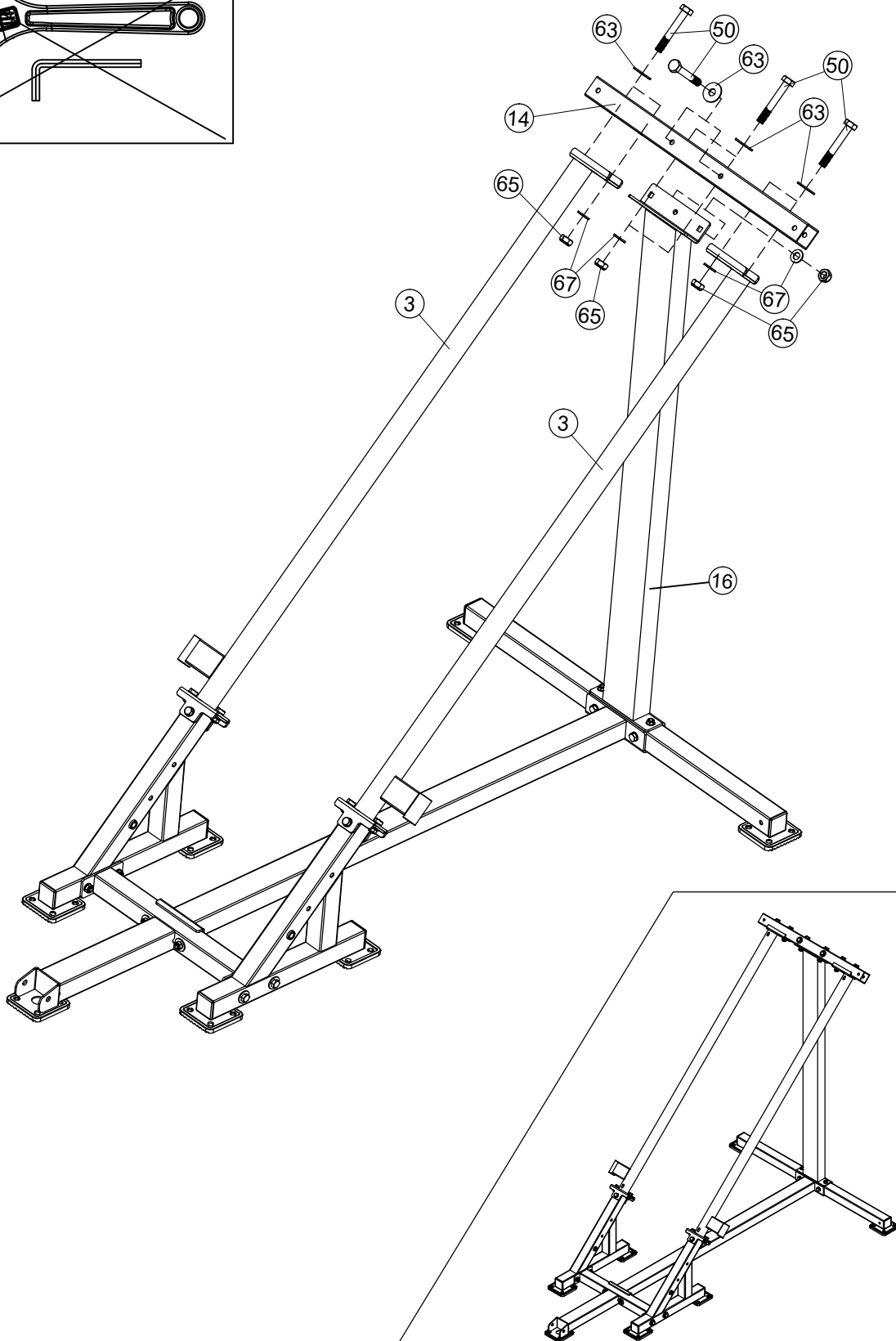
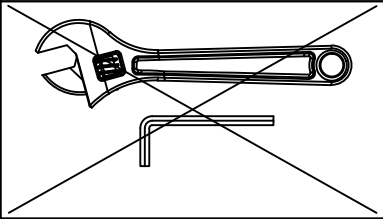

3

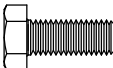
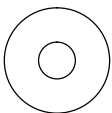

50		×8	M10×70mm	67		×6	Φ20×Φ10.5
63		×8	Φ30×Φ10.5	65		×6	M10

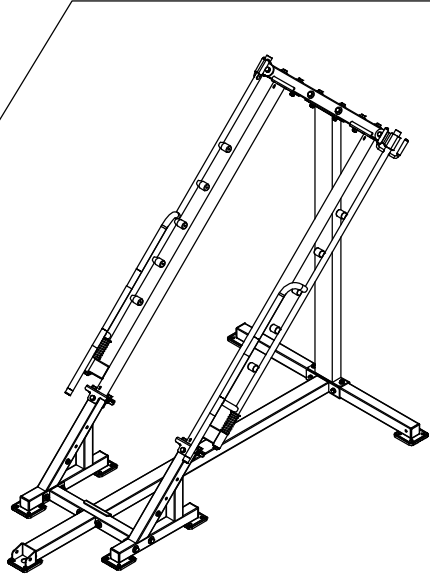
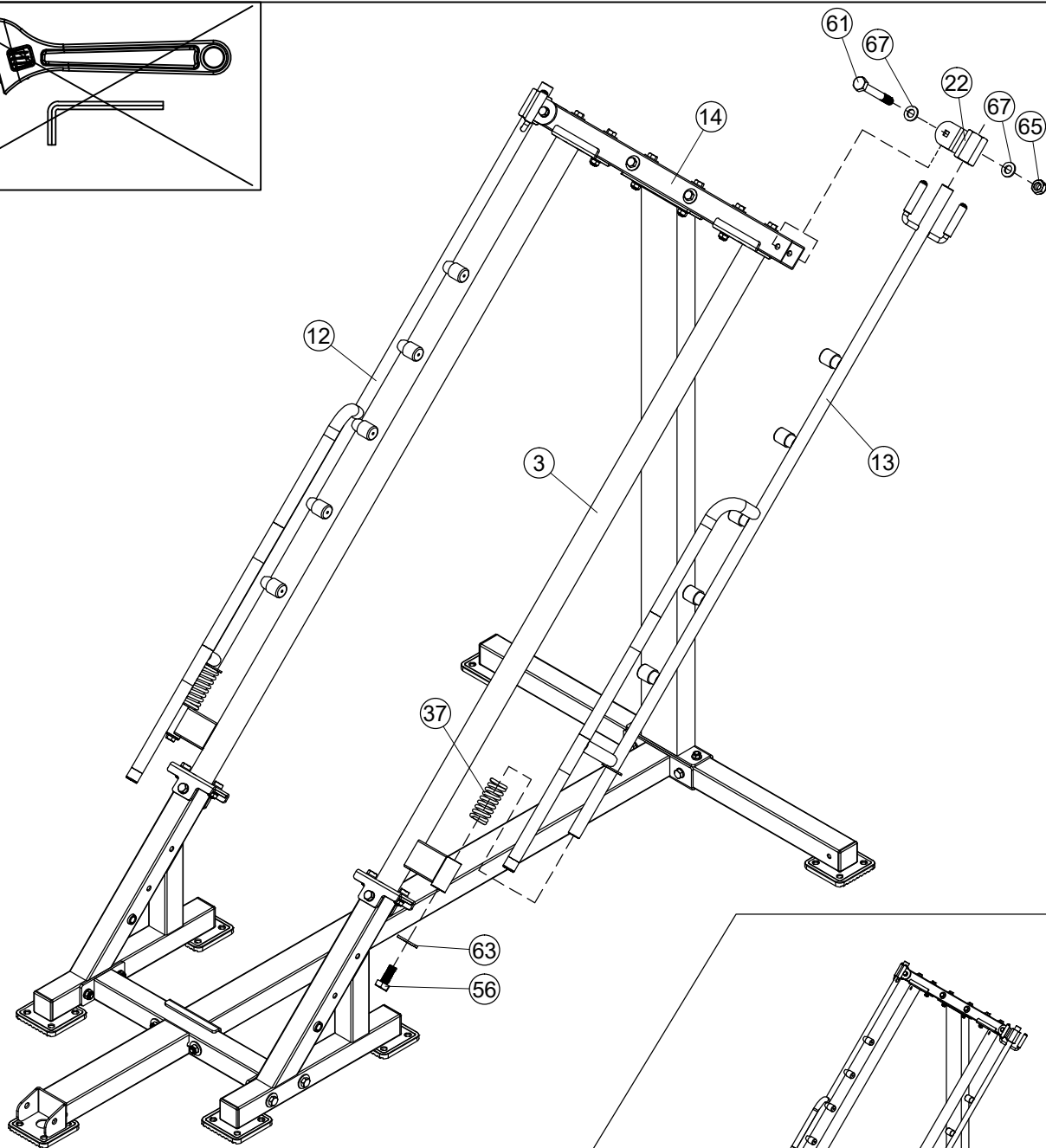
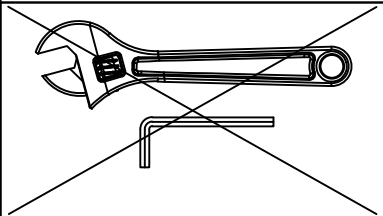

- (56)  ×2 M10×25mm (63)  ×2 Φ30×Φ10.5 (65)   ×2 M10
 (61)  ×2 M10×75mm (67)  ×4 Φ20×Φ10.5

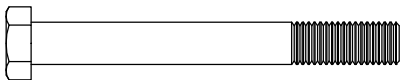
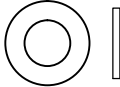

5

- (55)  ×8 M12× 105mm (66)  ×16 $\Phi 24 \times \Phi 13$
 (64)   ×8 M12

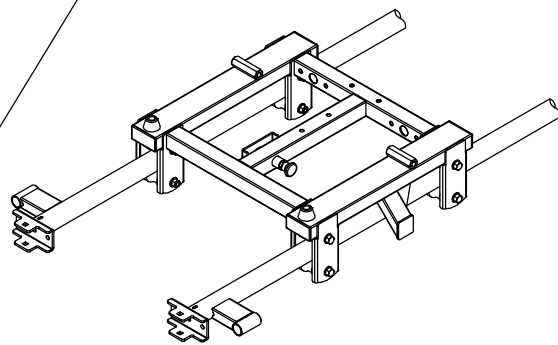
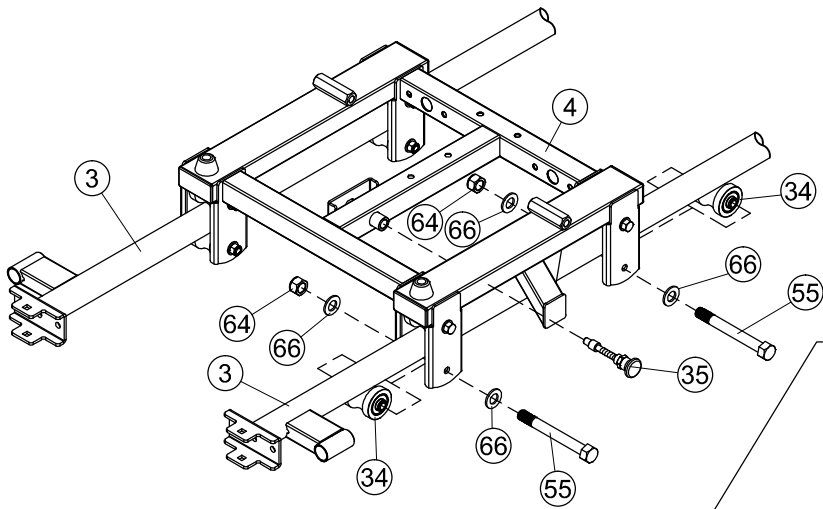
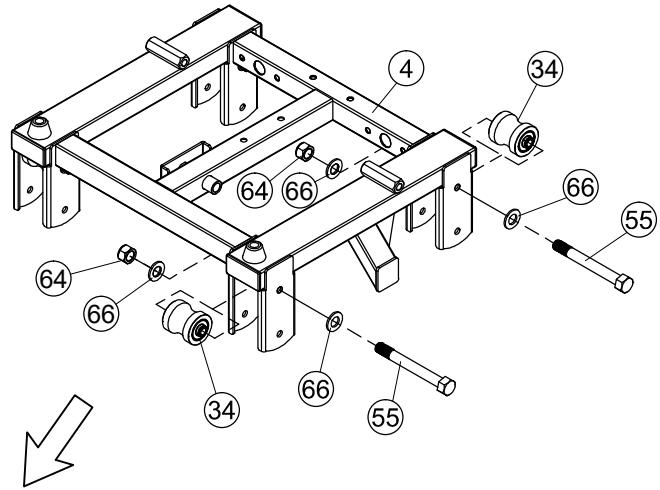
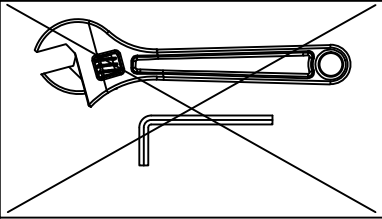

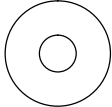

6

⑤⑩  ×4 M10×70mm

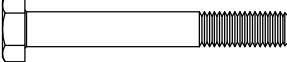
⑥③  ×2 Φ30×Φ10.5

⑥①  ×2 M10×75mm

⑥⑦  ×10 Φ20×Φ10.5

⑥⑤   ×6 M10

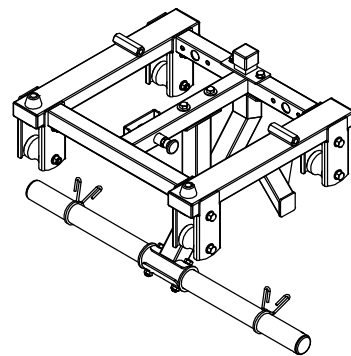
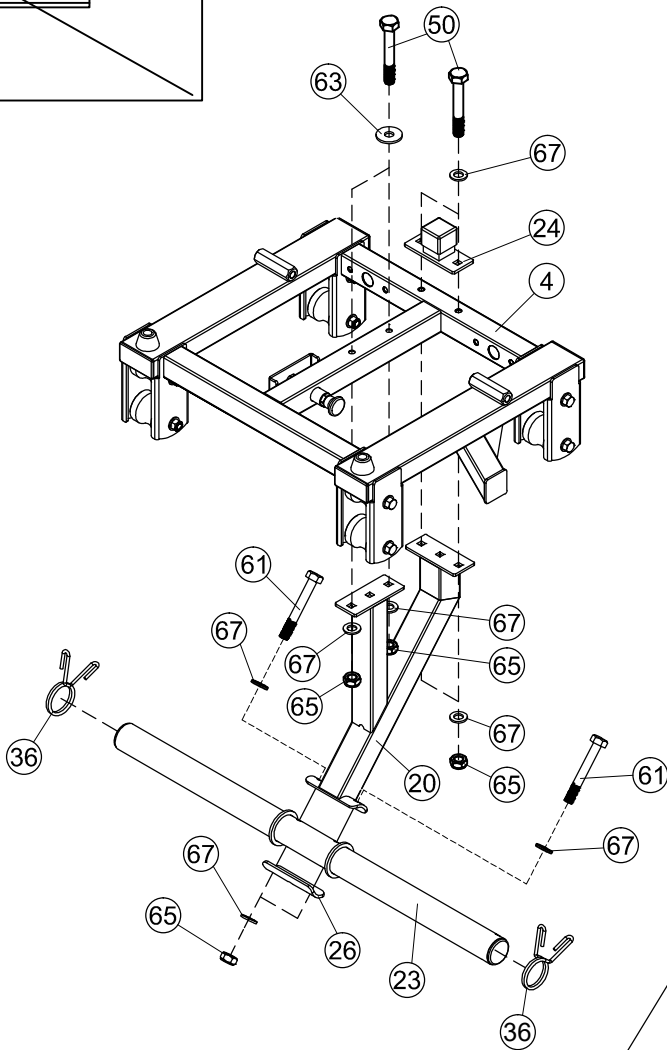
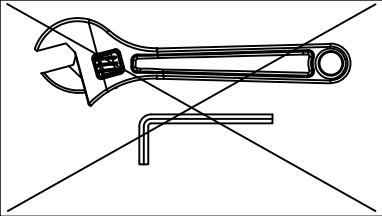

7

51  ×4 M10× 65mm

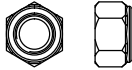
65  ×4 M10





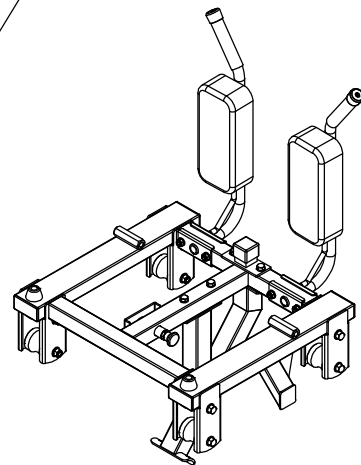
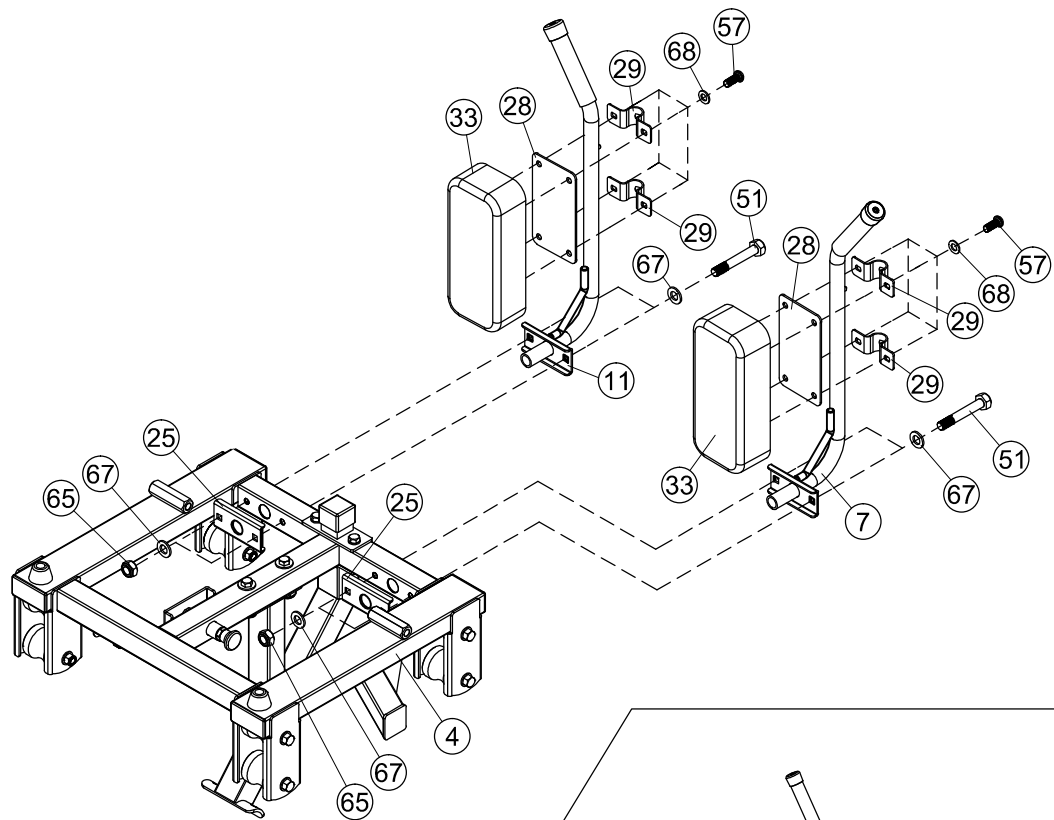
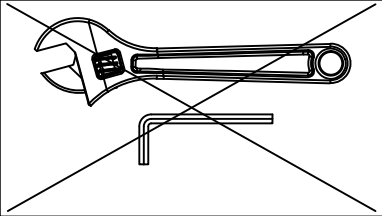

57  ×8 M8× 20mm

67  ×8 $\Phi 20 \times \Phi 10.5$

68  ×8 $\Phi 16 \times \Phi 8.4$

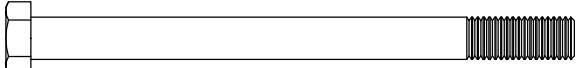



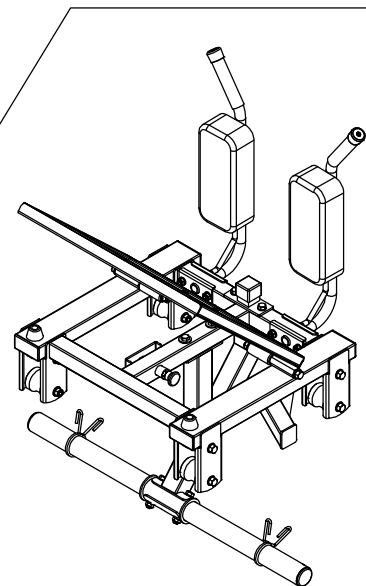
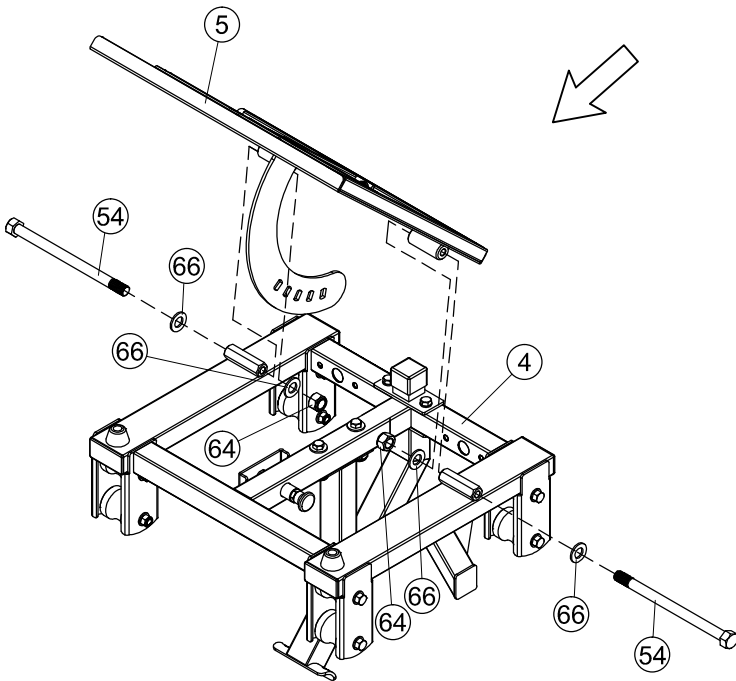
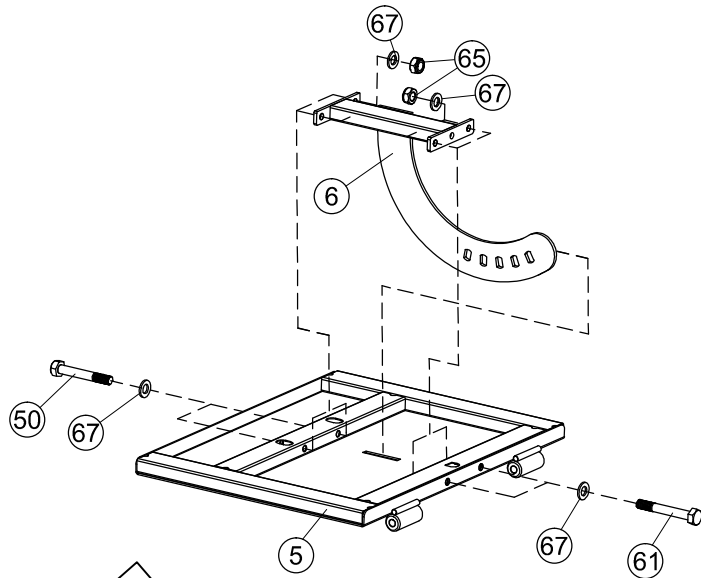
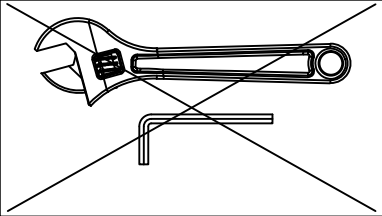

8

- (50)  ×2 M10× 70mm (64)  ×2 M12 (65)  ×4 M10
 (54)  ×2 M12× 175mm (66)  ×4 Φ24×Φ13
 (61)  ×2 M10× 75mm (67)  ×8 Φ20×Φ10.5

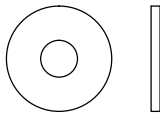
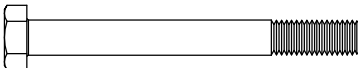
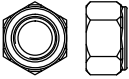
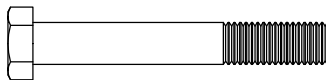

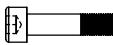
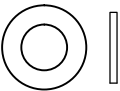
9

- | | | | | | |
|----|---|--------------|----|---|--------------|
| ⑤0 |  | ×4 M10× 70mm | ⑥3 |  | ×4 Φ30×Φ10.5 |
| ⑤2 |  | ×2 M10× 95mm | ⑥4 |  | ×2 M12 |
| ⑤3 |  | ×2 M12× 85mm | ⑥5 |  | ×6 M10 |
| ⑥2 |  | ×1 M6× 25mm | ⑥6 |  | ×4 Φ24×Φ13 |
| | | | ⑥7 |  | ×8 Φ20×Φ10.5 |

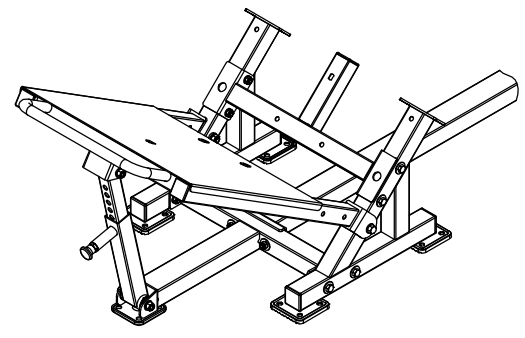
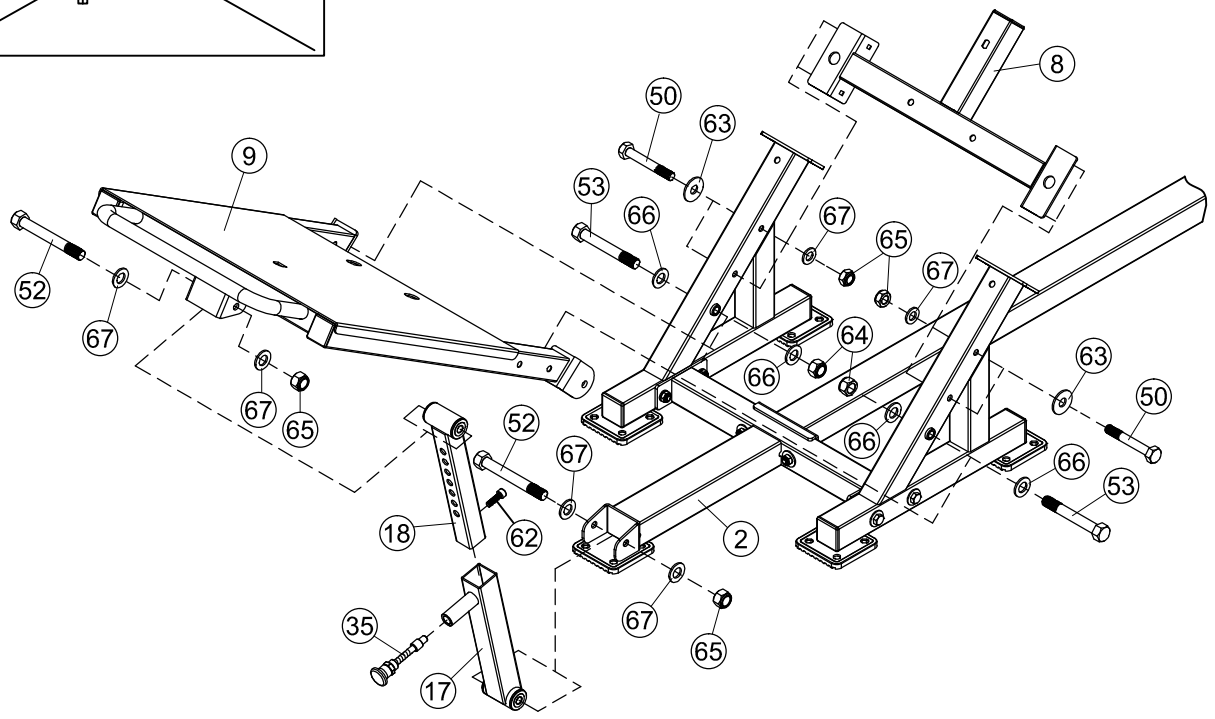
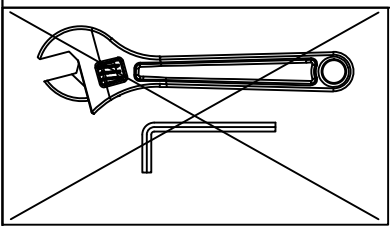

10

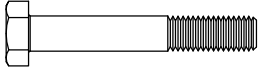
⑤①  ×4 M10×65mm

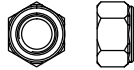
⑥⑤  ×4 M10

⑤⑧  ×3 M8×65mm

⑥⑦  ×8 Φ20×Φ10.5

⑤⑨  ×4 M8×20mm

⑥⑧  ×3 Φ16×Φ8.4

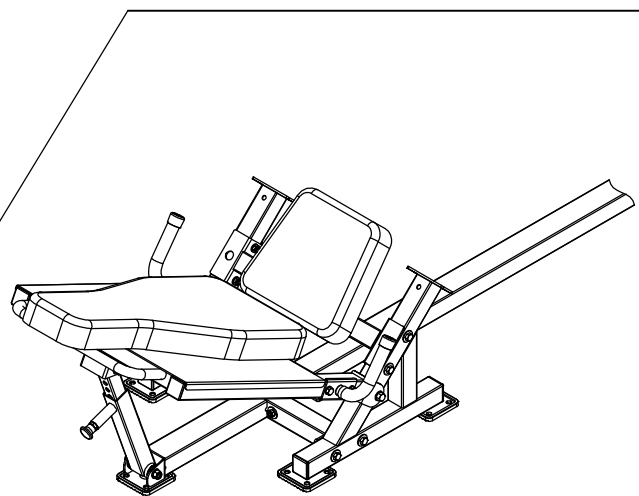
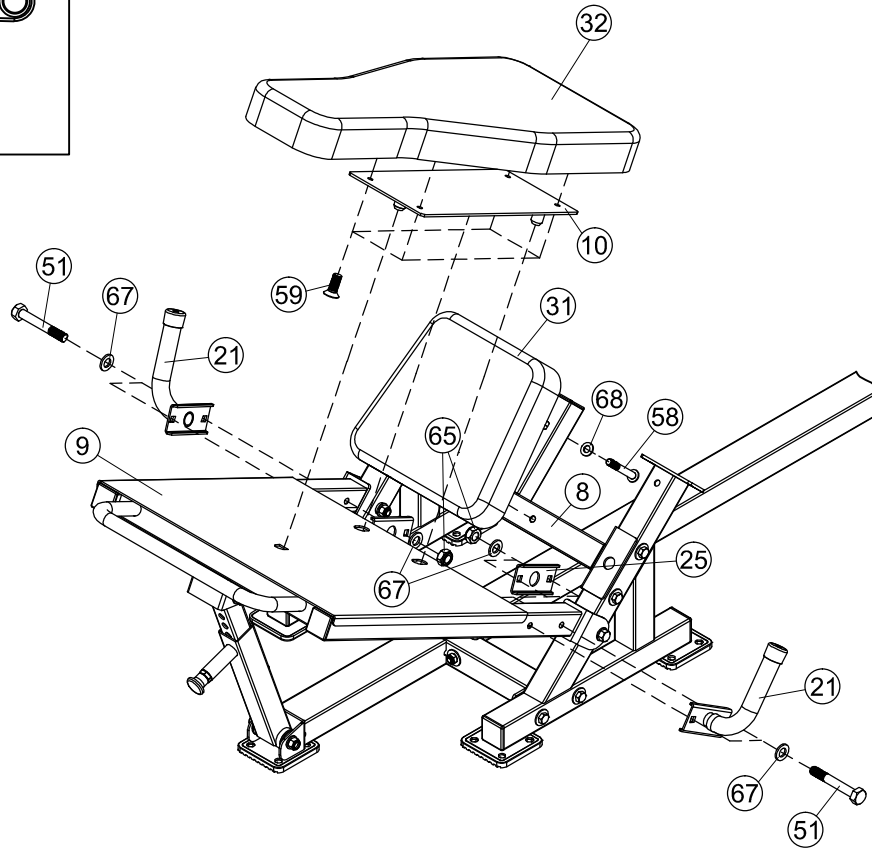
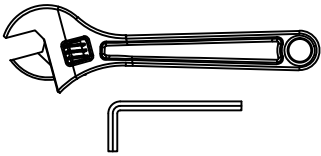

EXPLODED DRAWING

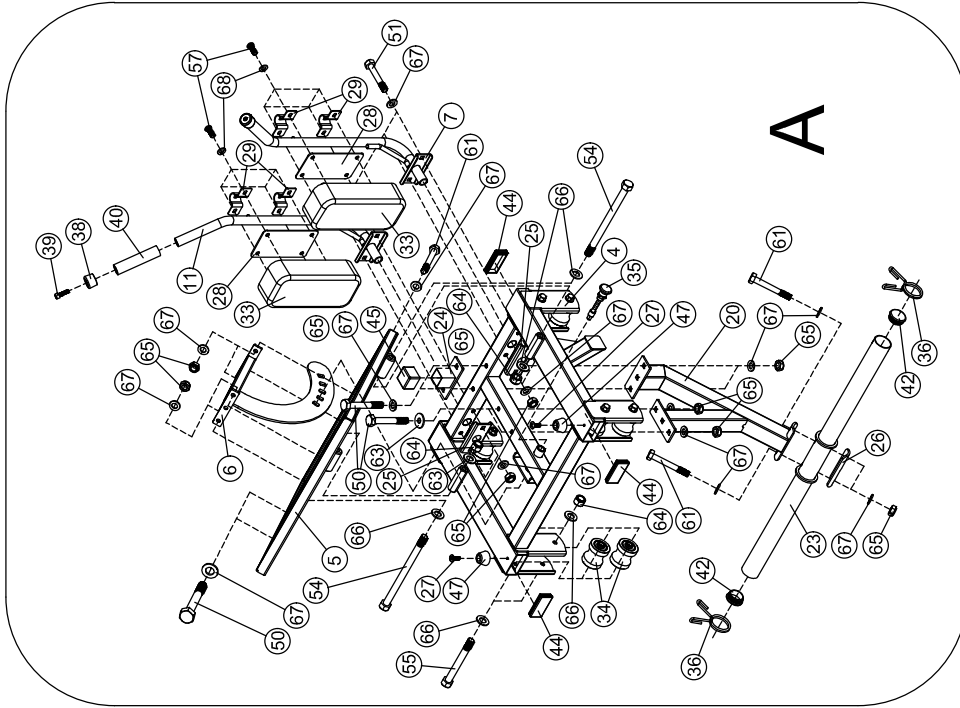
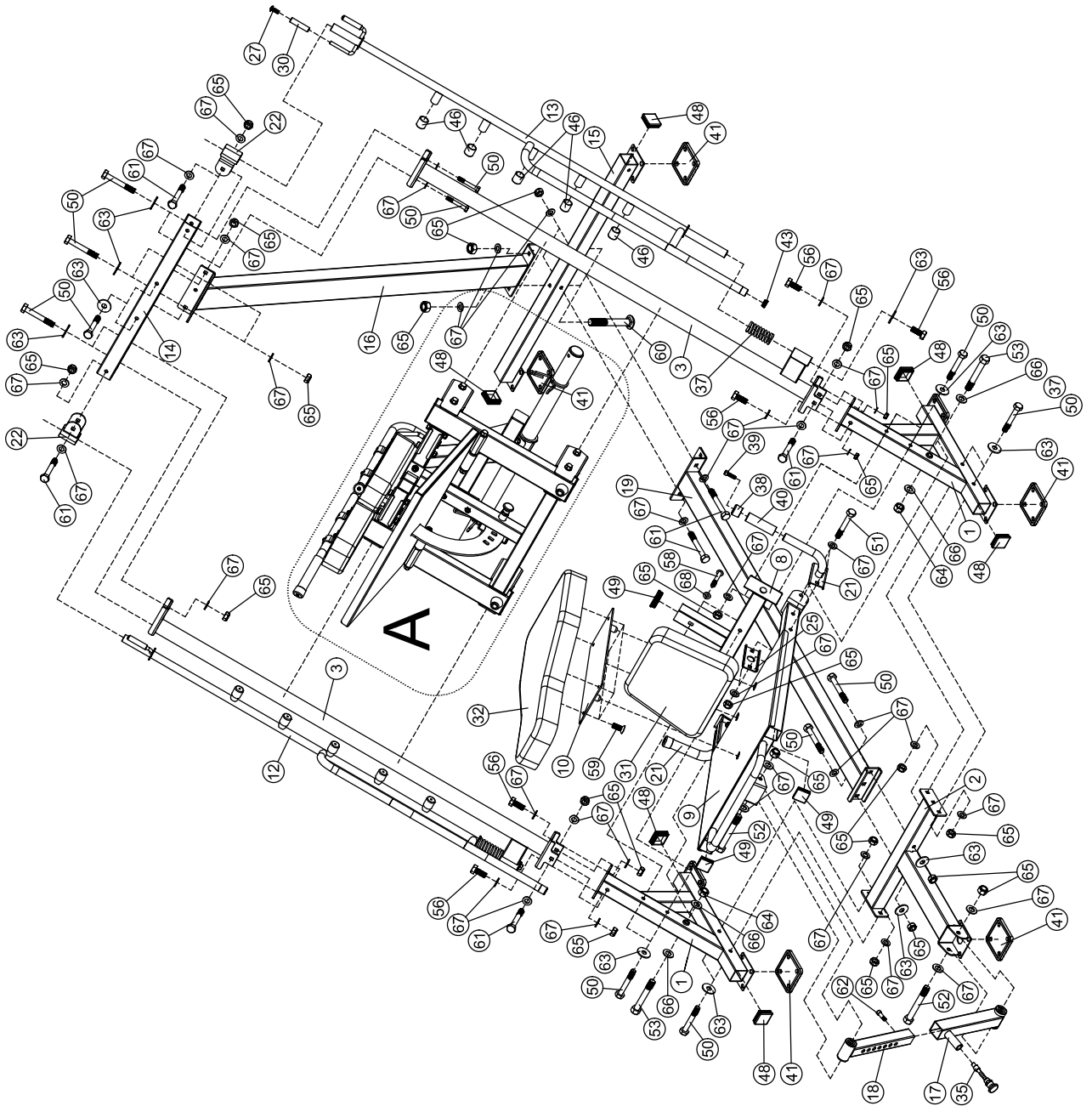

PARTS LIST

KEY NO.	PART DESCRIPTION	SPEC	QTY
1	Lower Support Frame		2
2	Rear Connecting Frame		1
3	Upper Support Frame		2
4	Sliding Frame		1
5	Upper Foot Frame		1
6	Upper Adjuster		1
7	Left Shoulder Pad Mount		1
8	Seat Frame		1
9	Lower Adjuster		1
10	Backrest Pad Mount		1
11	Right Shoulder Pad Mount		1
12	Left Lock Out		1
13	Right Lock Out		1
14	Upper Crossmember		1
15	Front Connecting Frame		1
16	Support Frame		1
17	Adjuster-Outside		1
18	Adjuster-Inside		1
19	Stabilizer		1
20	Lower Weight Carriage		1
21	Handle Frame		2
22	Fixed Structure		2
23	Barbell Rod		1
24	Limit Structure		1
25	Bracket	110×46×13×φ26×3	4
26	Bracket	120×R25×5	1
27	Philips Screw	M6×16	6
28	Bracket	185×100×3	2
29	Bracket	100×35×29×2.5	4
30	Buffer	φ16×φ10×67	4
31	Seat Pad		1
32	Backrest Pad		1
33	Shoulder Pad		2
34	Rollers		8
35	Moving Lock Pin		2

KEY NO.	PART DESCRIPTION	SPEC	QTY
36	Spring Clip	φ49	2
37	Spring		2
38	End Cap	φ33.5×25	4
39	Socket Head Allen Bolt	M6×15	4
40	Grip		4
41	Base Frame Cap		7
42	End Cap	φ50	2
43	End Cap	φ25	2
44	End Cap	□80×40	4
45	End Cap	□38	1
46	Bumper	φ30×φ25×30	10
47	Bumper	φ40×φ30×25	2
48	End Cap	□50	6
49	End Cap	□45	3
50	Hex Bolt	M10×70	24
51	Hex Bolt	M10×65	8
52	Hex Bolt	M10×95	2
53	Hex Bolt	M12×85	2
54	Hex Bolt	M12×175	2
55	Hex Bolt	M12×105	8
56	Hex Bolt	M10×25	6
57	Allen Bolt	M8×20	8
58	Allen Bolt	M8×65	3
59	Socket countersunk head screw	M8×20	4
60	Carriage Bolt	M10×75	2
61	Hex Bolt	M10×75	10
62	Socket Head Allen Bolt	M6×25	1
63	Washer	φ30×φ10.5	22
64	Aircraft Nut	M12	12
65	Aircraft Nut	M10	48
66	Washer	12	24
67	Washer	10	76
68	Washer	8	11
	Allen Wrench	5#	1

FRENCH FITNESS

FF-PLHSLP

FRENCH FITNESS P/L HACK SQUAT
LEG PRESS COMBO

EXERCISES



HACK SQUAT



START



END

LEG PRESS



START



END

CALF RAISE



START



END