

FRENCH FITNESS

Product Code: FF-DFIB-FSR

Decline Flat Incline Bench

ASSEMBLY MANUAL

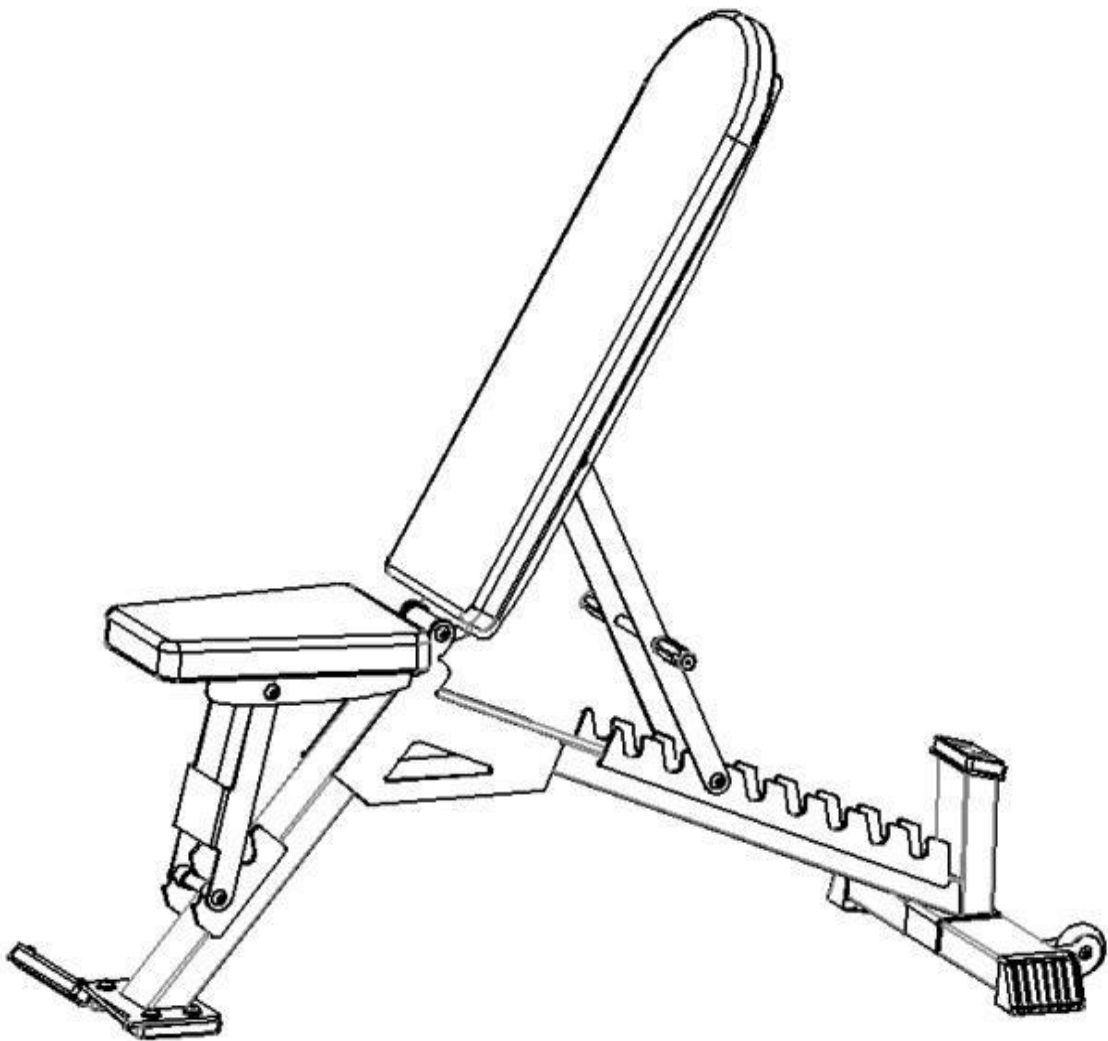

FEATURES

- 8 adjustable incline/flat/decline
- Adjustable angle -15 to 85 degree
- Cushion angle adjustable in 3 levels
- 50mm PVC seat cushion
- Polyurethane foam
- Maximum Load Capacity: 600 lbs (User Weight + Weight Load)

TECH SPECS

- Weight: 71 lb (32 kg)
- Dimensions (L x W x H): 54 in x 22 in x 19 in (1350 mm x 540 mm x 470 mm)

WARRANTY

- 10 Years Parts, 1 Year Labor (Home)

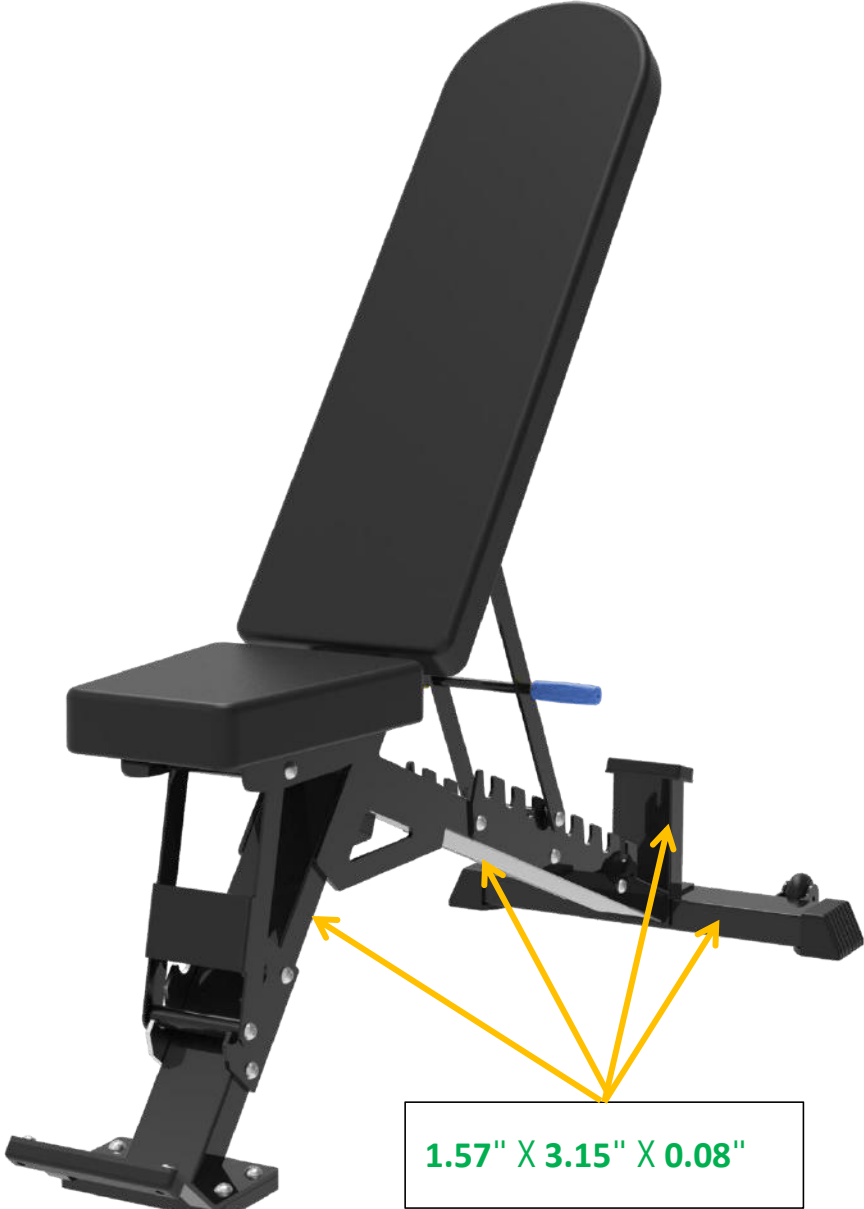

DFIB-FSR

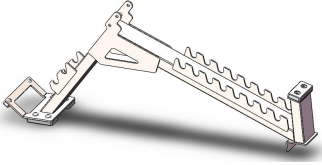
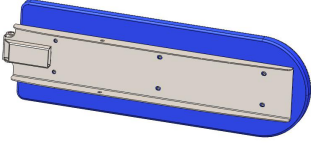
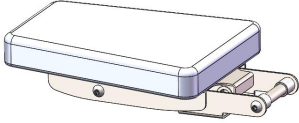
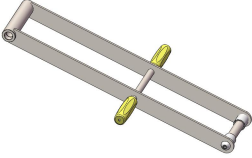
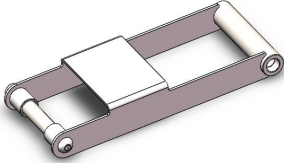
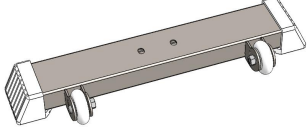
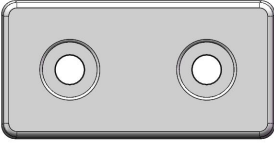
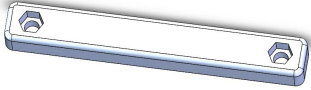
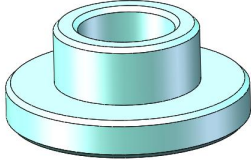

ASSEMBLY INSTRUCTION

Parts List					
					
#1	Tripod welding group*1 set	#2	Back part components*1 set	#3	Front seat cushion assembly* 1 set
					
#4	Backrest support assembly*1 set	#5	Seat support welding group*1	#6	Rear base assembly*1 set
					
#7	Suspension gaskets *3	#8	polymer plank *1	#9	Nylon sleeve*8 set

Screw package Lists

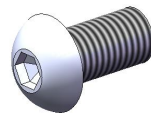
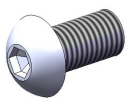
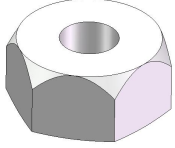
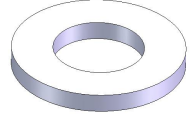
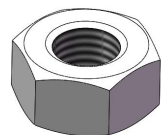
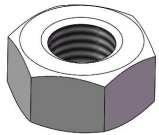
Screw package Lists					
					
A	M10*150 Hexagon socket flat head screws*2pcs	B	M10*100Hexagon socket flat head screws*2pcs	C	M10*20Hexagon socket flat head screws *6pcs
					
D	M8*20Hexagon socket flat head screws *2pcs	E	M10 Locknut *4pcs	F	Ø10 Flat gasket*8pcs
					
G	M10 Hexagonal nut *4pcs	H	M8 Hexagonal nut *2pcs		

Assembly Steps

Steps	Numbers	Name	Quantity	Number	Name	QTY
1	#1	Tripod welding group	1	D	M8*20Hexagon socket flat head	2
	#7	Suspension gaskets	3	G	M10 Hexagonal nut	4
	#8	polymer plank	1	F	Ø10 Flat gasket	4
	C	M10*20Hexagon socket flat head screws	6	H	M8 Hexagonal nut	2

Tools

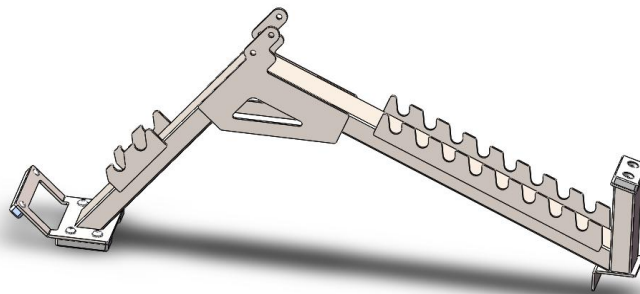
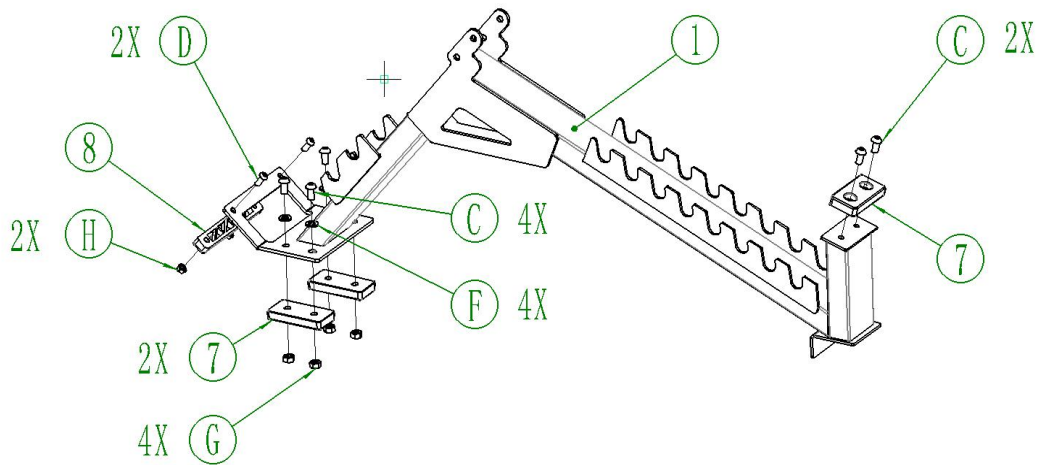

Install the main frame accessories as shown

Assembly steps

Steps	Number	Name	QTY	Number	Name	QTY
2	6#	Rear base assembly	1			
	C	M10*20Hexagon socket flat head screws	2			

Tools

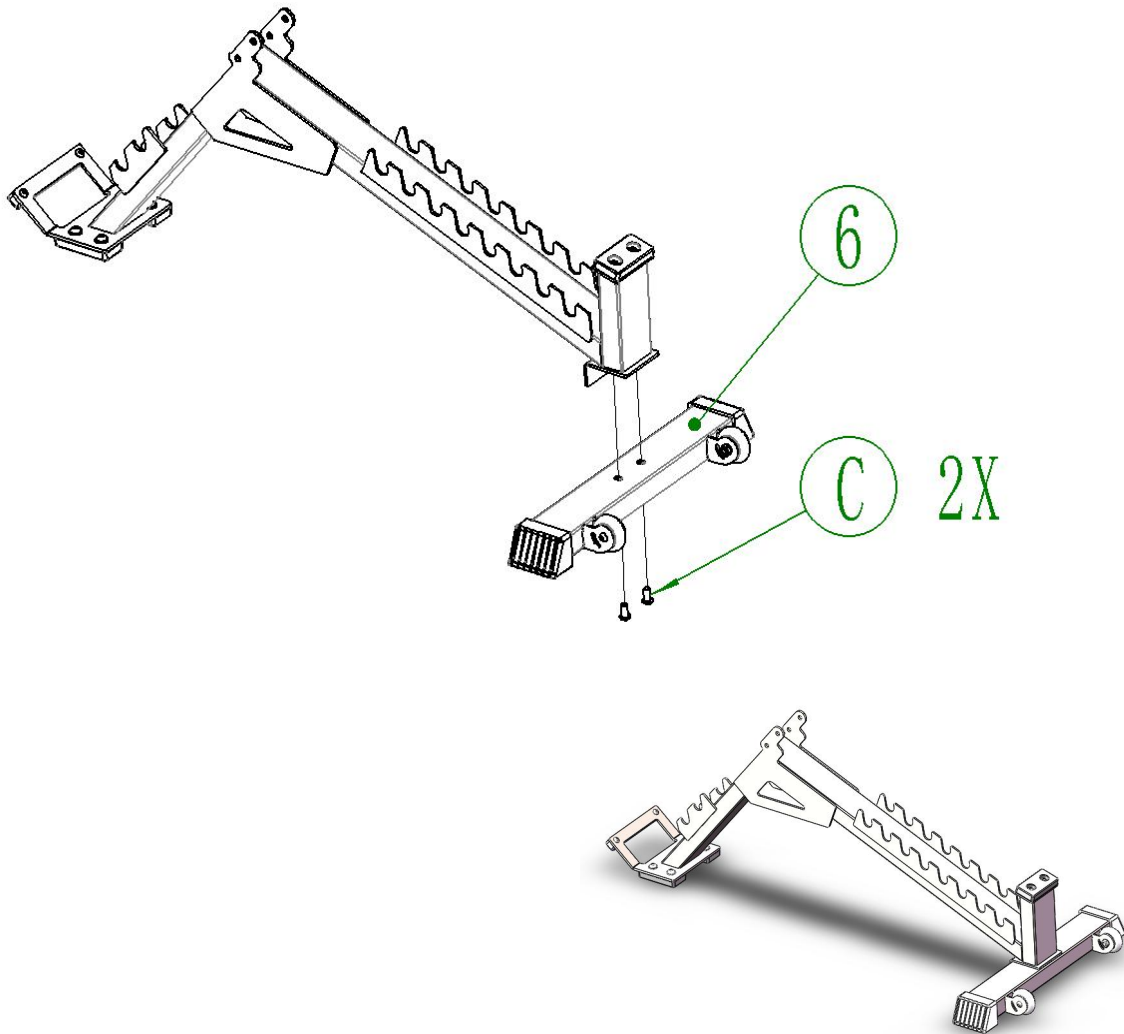

Install Rear base assembly

Assembly steps

Step	Number	Name	QTY	Number	Name	QTY
3	#2	Back part components	1	E	M10 Locknut	1
	#4	Backrest support assembly	1	F	Ø10 Flat gasket	1
	#9	Nylon sleeve	2			
	A	M10*150 Hexagon socket flat head screws	1			

Tools

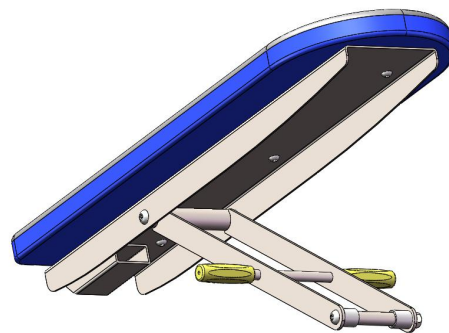
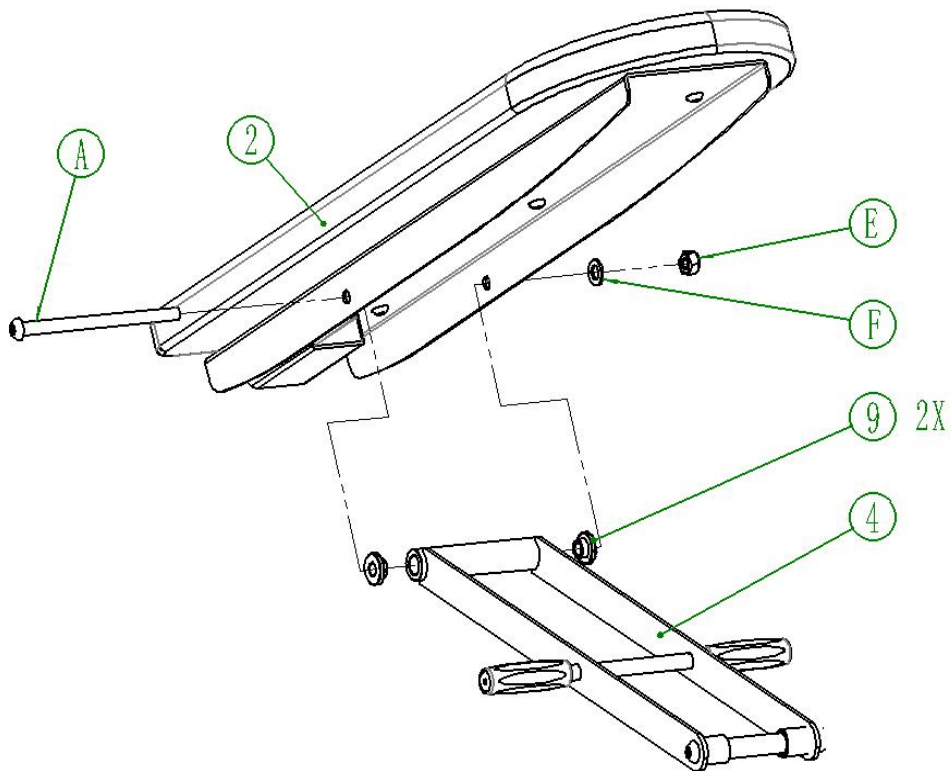

As shown in the picture, install the backrest group

Assembly steps

Steps	Number	Name	QTY	Number	Name	QTY
4	#2	Back part components	1	F	Ø10 Flat gasket	1
	#9	Nylon sleeve	2			
	B	M10*100Hexagon socket flat head screws	1			
	E	M10 Locknut	1			

Tools

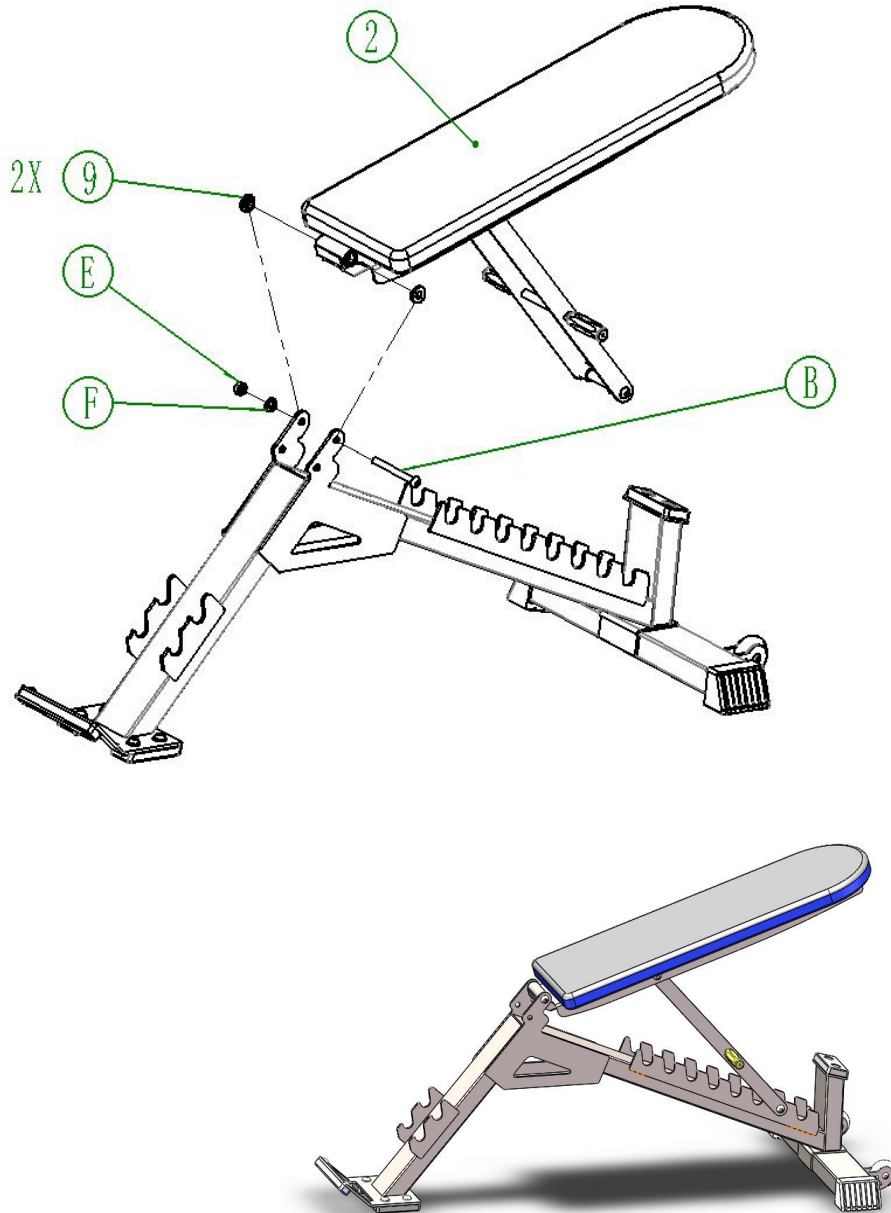

As shown in the picture, install the backrest assembly

Assembly steps

Steps	Number	Name	QTY	Number	Name	QTY
5	#3	Front seat cushion assembly	1	E	Ø10 Flat gasket	1
	#5	Seat support welding group	1	F	M10 Locknut	1
	#9	Nylon sleeve	2			
	A	M10*150 Hexagon socket flat head screws	1			

Tool

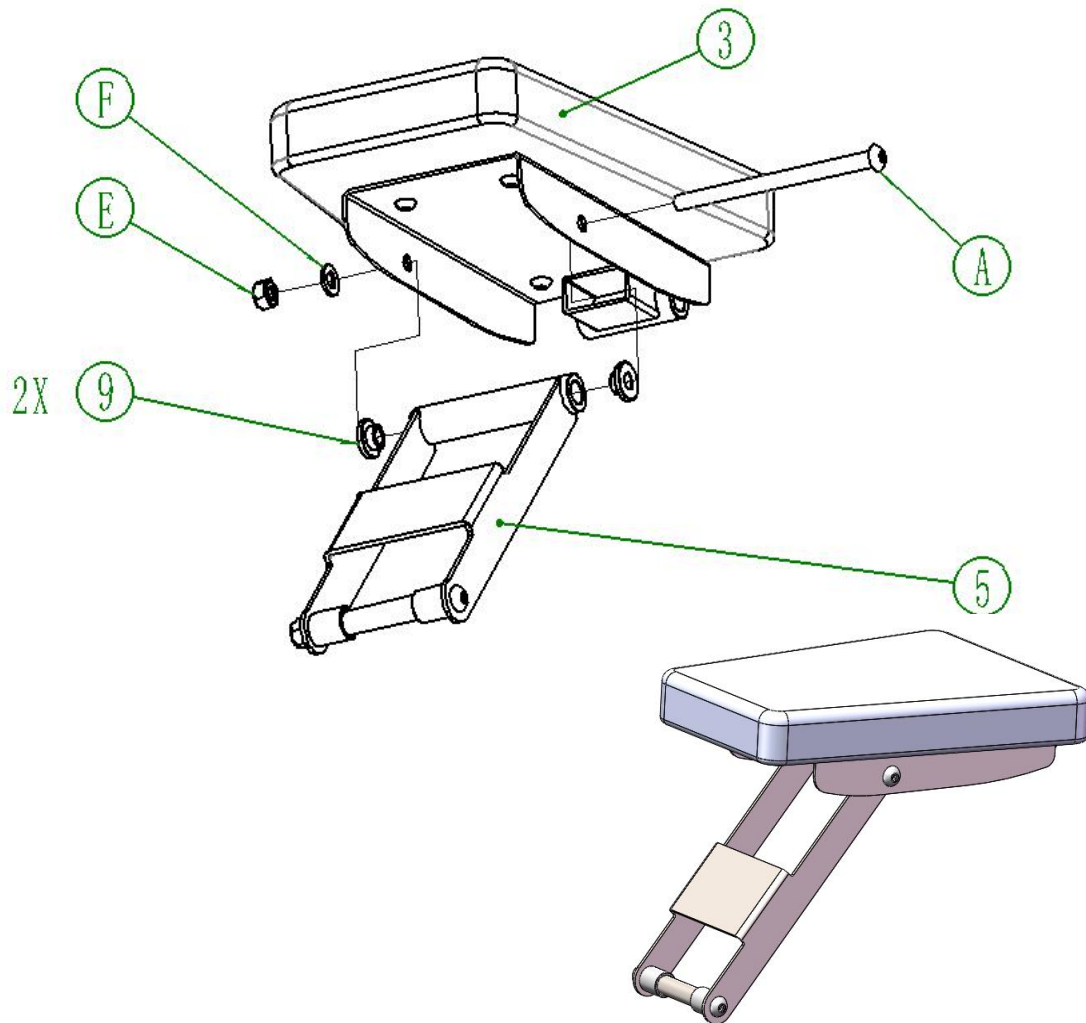

Install the cushion support group

Assembly steps

Steps	Number	Name	QTY	Number	Name	QTY
6	#3	Front seat cushion assembly	1	F	M10 Locknut	1
	#9	Nylon sleeve	2			
	B	M10*100Hexagon socket flat head screws	1			
	E	Ø10 Flat gasket	1			

Tools

6# Hexagon screwdriver,wrench

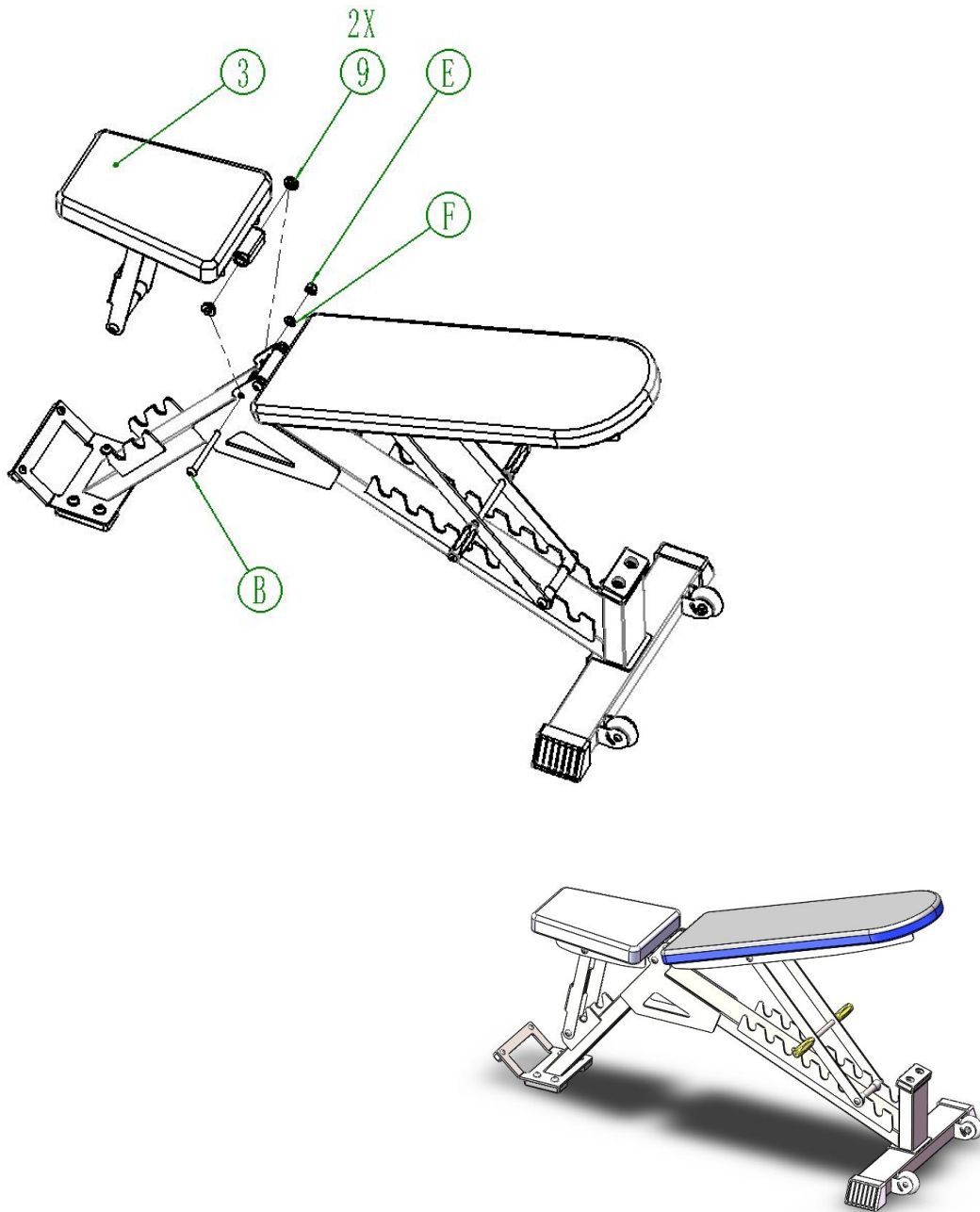

As shown in the figure, install the front seat cushion assembly to complete all assembly.