

# FREEMOTION® | EXT

## Dual Cable Cross™

### USER'S MANUAL

Model No. VFMCS4007.0

Serial No. \_\_\_\_\_

Write the serial number in the space above for future reference.

Serial Number Decal  
(inside tower)

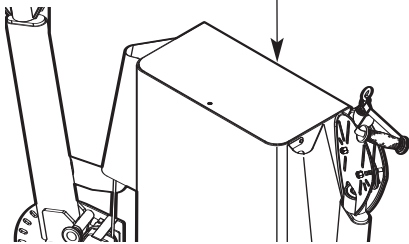

### QUESTIONS?

At FreeMotion Fitness, we are committed to providing complete customer satisfaction. If you have questions, please contact the authorized dealer where you purchased the strength equipment.

### CAUTION

Read all precautions and instructions in this manual before using this equipment. Save this manual for future reference.

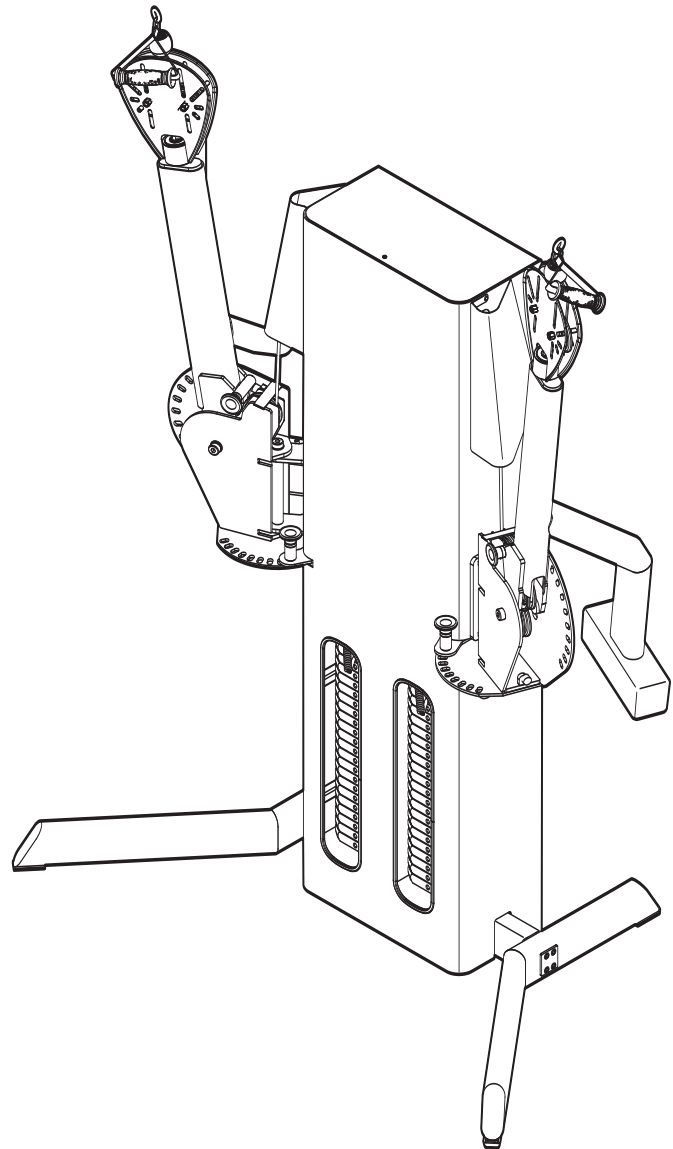

Visit our website at

[www.freemotionfitness.com](http://www.freemotionfitness.com)

---

# TABLE OF CONTENTS

WARNING DECAL PLACEMENT .....	3
IMPORTANT PRECAUTIONS .....	4
BEFORE YOU BEGIN .....	5
ASSEMBLY .....	6
ADJUSTMENT .....	11
MAINTENANCE .....	12
CABLE DIAGRAM .....	13
EXERCISE GUIDELINES .....	14
LIMITED WARRANTY .....	16
PART LIST .....	17
EXPLODED DRAWING .....	18
HOW TO CONTACT CUSTOMER CARE .....	Back Cover

# WARNING DECAL PLACEMENT

The decals shown here have been applied in the indicated locations. If a decal is missing or illegible, see HOW TO CONTACT CUSTOMER CARE on the back cover of this manual and order a free replacement decal. Apply the decal in the location shown. Note: The decals may not be shown at actual size.



Decal 1 (GZ7008)



Decal 2 (GZ7006)

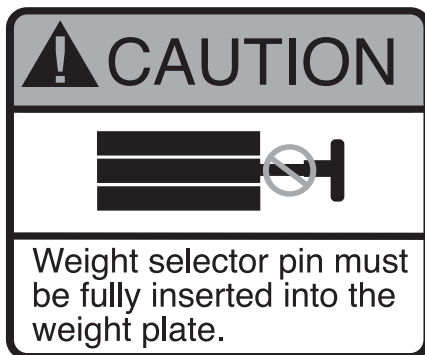

Decal 3 (GZ7026)

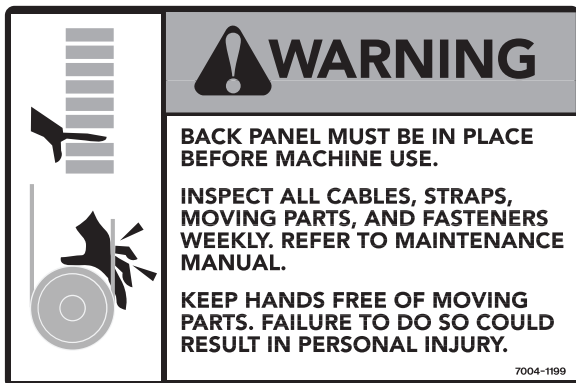

Decal 4 (GZ7004)

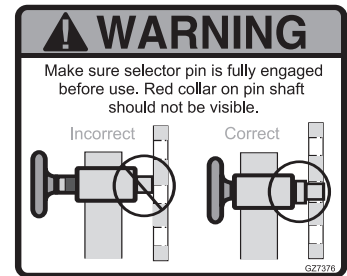
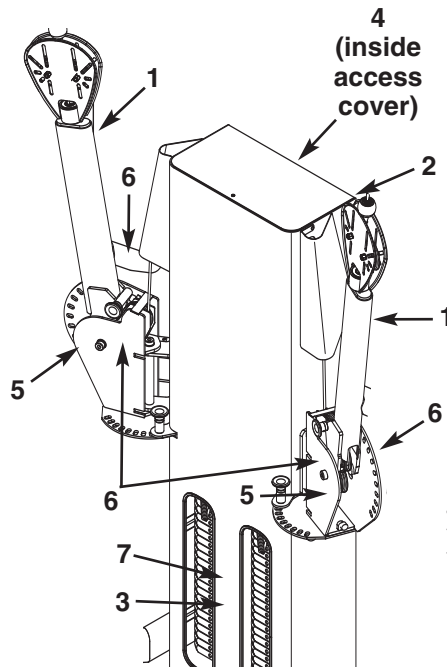

Decal 5 (GZ7376)



Decal 6 (GZ7005)

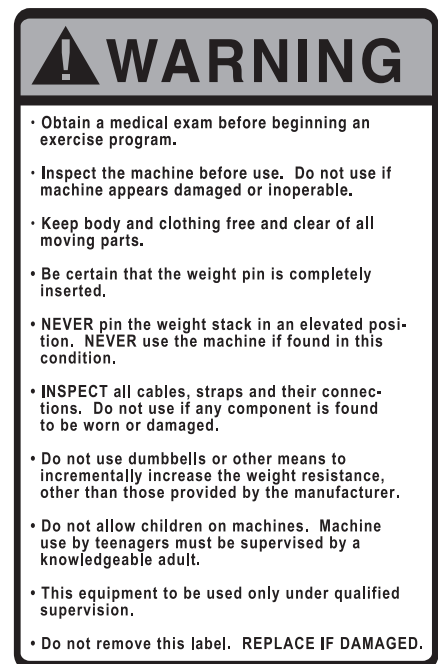

Decal 7 (GZ7003)

---

# IMPORTANT PRECAUTIONS

**⚠️ WARNING:** To reduce the risk of serious injury, read all important precautions and instructions in this manual and all warnings on the strength equipment before using the strength equipment. FreeMotion Fitness assumes no responsibility for personal injury or property damage sustained by or through the use of the strength equipment.

1. Before beginning any exercise program, consult your physician. This is especially important for persons over the age of 35 or persons with pre-existing health problems.
2. Use the strength equipment only as described in this manual.
3. It is the responsibility of the owner to ensure that all users of the strength equipment are adequately informed of all precautions.
4. Keep the strength equipment indoors, away from moisture and dust. Place the strength equipment on a level surface, with a mat beneath it to protect the floor or carpet. Make sure that there is enough clearance around the strength equipment to mount, dismount, and use it.
5. Keep hands and feet away from moving parts.
6. Keep children under age 12 and pets away from the strength equipment at all times.
7. The strength equipment is designed to support a maximum user weight of 350 lbs. (159 kg).
8. Wear appropriate athletic clothes while exercising. Always wear athletic shoes for foot protection while exercising.
9. Inspect and properly tighten all parts regularly. Replace any worn parts immediately.
10. Make sure that the cables remain on the pulleys at all times. If a cable binds while you are exercising, stop immediately and make sure that the cable is on the pulleys.
11. Make sure that the weight pins are fully inserted into the weight stacks before you exercise.
12. Make sure the four adjustment knobs are fully engaged before you exercise.
13. If you feel pain or dizziness while exercising, stop immediately and cool down.

# BEFORE YOU BEGIN

Thank you for selecting the FREEMOTION® EXT DUAL CABLE CROSS™ strength equipment. With unrestricted motion, you can work your body's muscle groups together in a way that simulates everyday movement. This will allow you to train more effectively for specific activities. Whether your goal is to tone your body, build dramatic muscle size and strength, or improve your cardiovascular system, the strength equipment will help you to achieve the specific results you want.

**For your benefit, read this manual carefully before**

**you use the strength equipment.** If you have questions after reading this manual, please contact the authorized dealer where you purchased the strength equipment. Please note the product model number and serial number before contacting the authorized dealer. The model number and the location of the serial number decal are shown on the front cover of this manual.

Before reading further, please review the drawing below and familiarize yourself with the parts that are labeled.

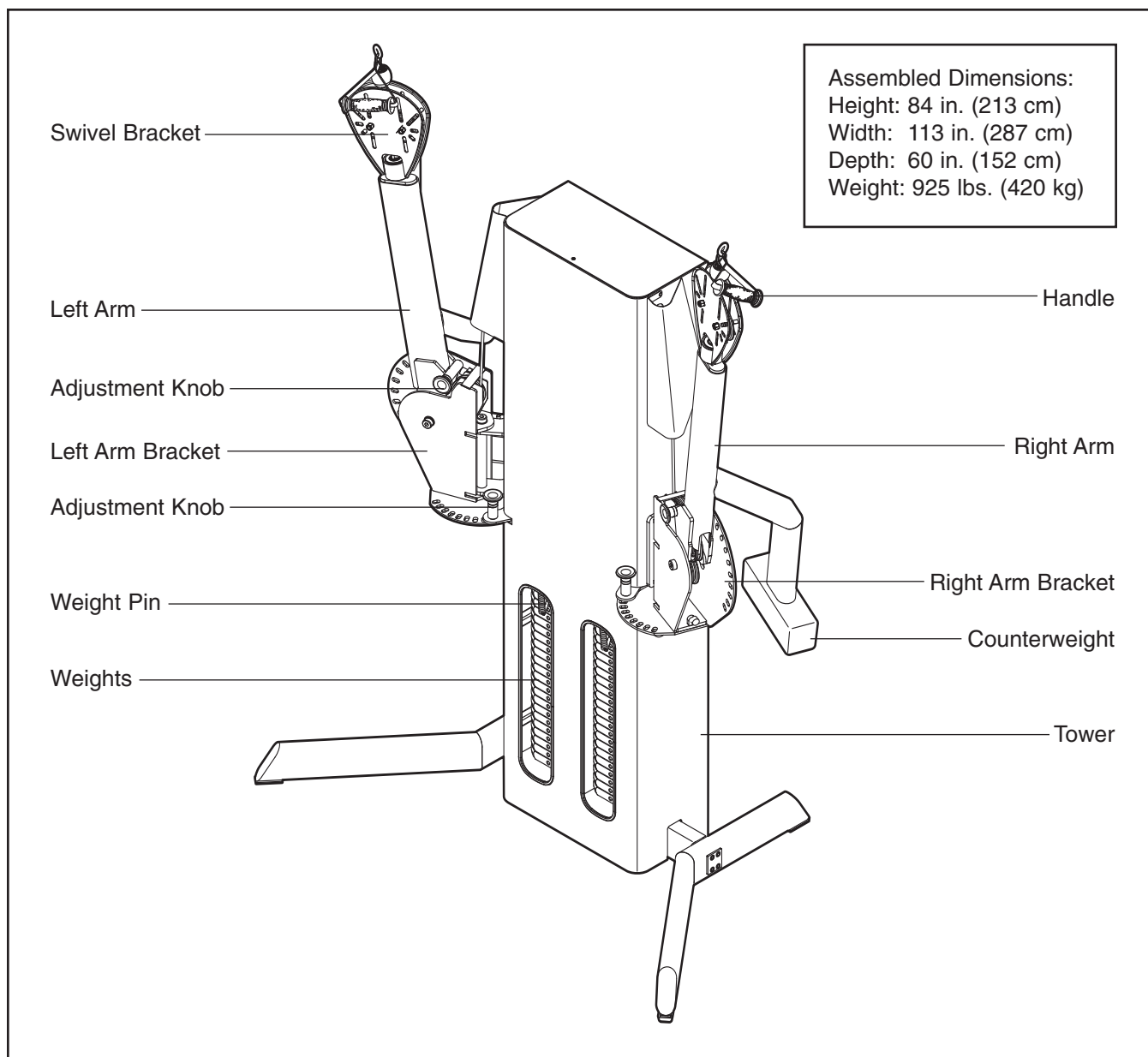

# ASSEMBLY

## Make Assembly Easier

Everything in this manual is designed to ensure that the strength equipment can be assembled successfully by almost anyone. By setting aside plenty of time, assembly will go smoothly.

### Before beginning assembly, carefully read the following information and instructions:

- Assembly requires two persons.
- Because of its weight and size, the strength equipment should be assembled in the location where it will be used. Make sure that there is enough clearance to walk around the strength equipment as you assemble it.
- Place all parts in a cleared area and remove the packing materials. Do not dispose of the packing materials until assembly is completed.

- As you assemble the strength equipment, orient all parts exactly as shown in the drawings.
- Tighten all parts as you assemble them, unless instructed to do otherwise.
- The following tools (not included) may be required for assembly:

two adjustable wrenches 

one rubber mallet 

one standard screwdriver 

one Phillips screwdriver 

three hex keys 

Assembly will be more convenient if you have a socket set, a set of open-end or closed-end wrenches, or a set of ratchet wrenches.

1.

**Before beginning assembly, make sure that you understand the information in the box above. Note: Some parts described in the assembly steps may be preassembled.**

Have another person hold the Tower (1) and tip it to one side slightly. Attach the Right Leg (3) to the Tower with four 3/8" x 3" Bolts (70), one 3/8" x 1" Bolt (50), and one 3/8" Washer (78). **Do not tighten the Bolts yet.**

**Attach the Left Leg (4) in the same way.**

**Tighten the eight 3/8" x 3" Bolts (70) and the two 3/8" x 1" Bolts (50).**

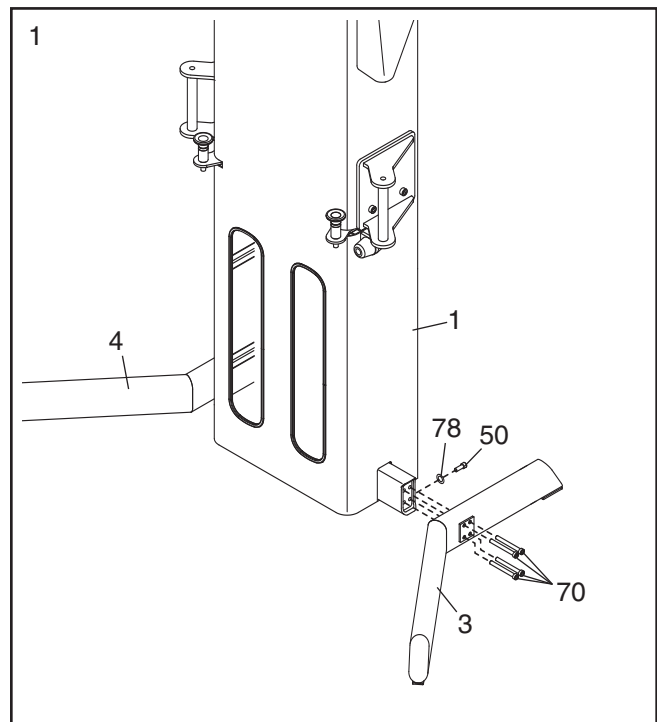

- Lift the indicated Adjustment Knob (60), slide the Left Arm Bracket (9) onto the left Pivot (59), and engage the Adjustment Knob in one of the adjustment holes in the Left Arm Bracket.

Attach the Left Arm Bracket (9) to the left Pivot (59) with two 3/4" x 1/2" Shoulder Bolts (42).

**Attach the Right Arm Bracket (10) in the same way.**

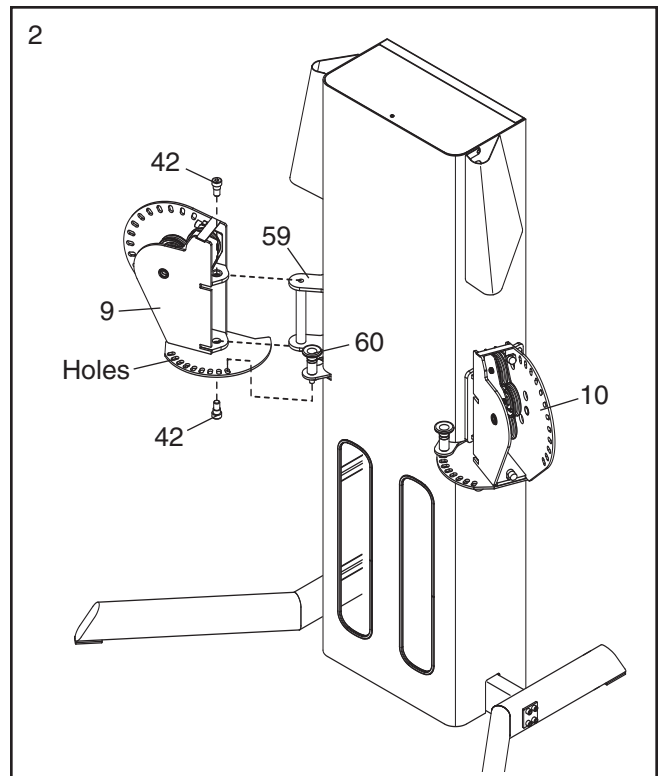

- Pull the Adjustment Knob (60) on the Left Arm (5), hold the end of the Left Arm inside the Left Arm Bracket (9), and engage the Adjustment Knob in one of the adjustment holes in the Left Arm Bracket.

Attach the Left Arm (5) to the Left Arm Bracket (9) with two 3/4" x 1/2" Shoulder Bolts (42).

Next, attach a Counterweight (7) to the Left Arm (5) with two 3/8" x 4 1/2" Screws (11).

**Attach the Right Arm (6) and the other Counterweight (not shown) in the same way.**

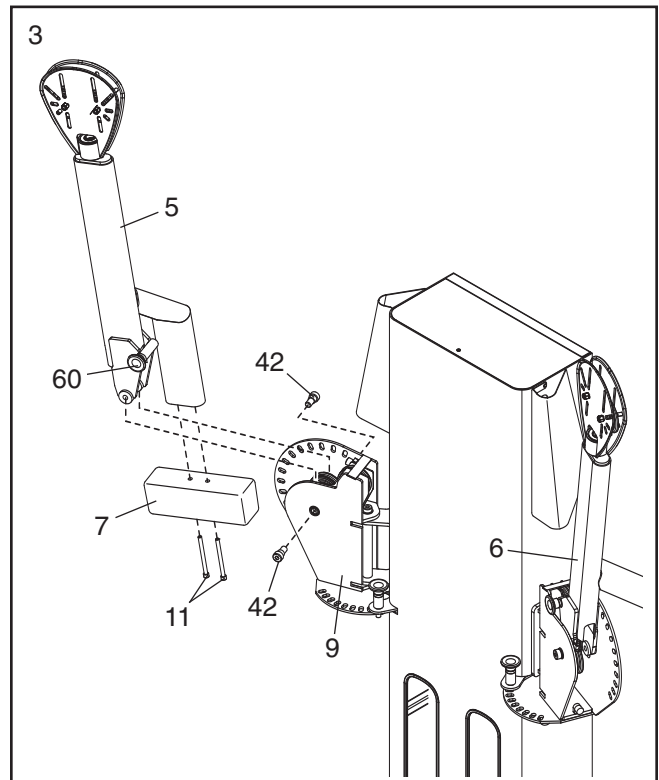

4. Remove the eight 1/4" x 3/4" Screws (35) from the Access Cover (2) on the back of the Tower (1). Then, remove the Access Cover.

Next, remove the two Top Weights (15) and the Left and Right Weight Rods (14, 63) from the Tower (1).

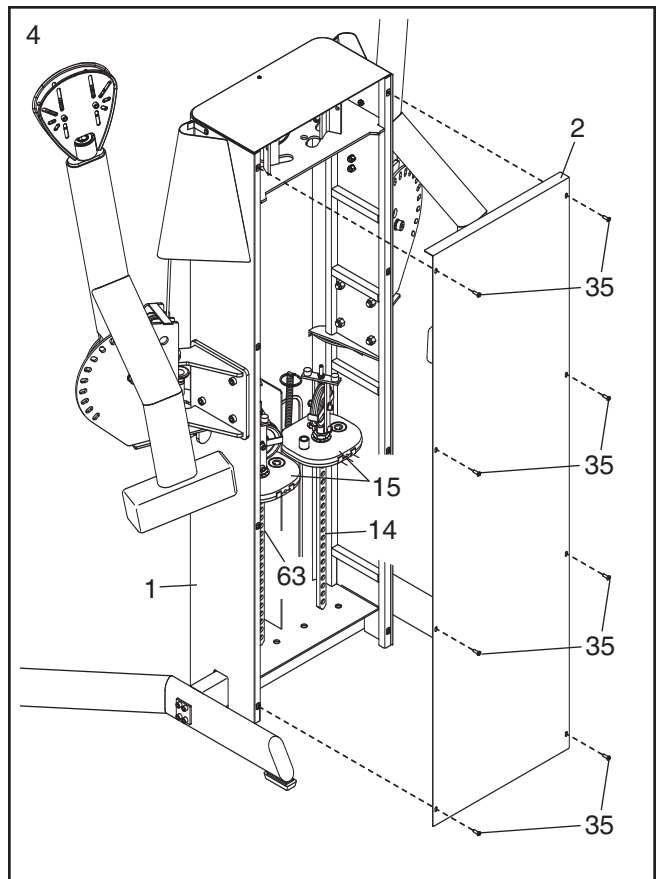

5. Set a Weight Bumper (22) over the indicated hole in the Tower (1). Then, orient a Weight Guide Rod (21) so that the threaded end is at the top, and insert the Weight Guide Rod into the Weight Bumper and the hole.

**Repeat this step with the other three Weight Bumpers (22) and Weight Guide Rods (21).**

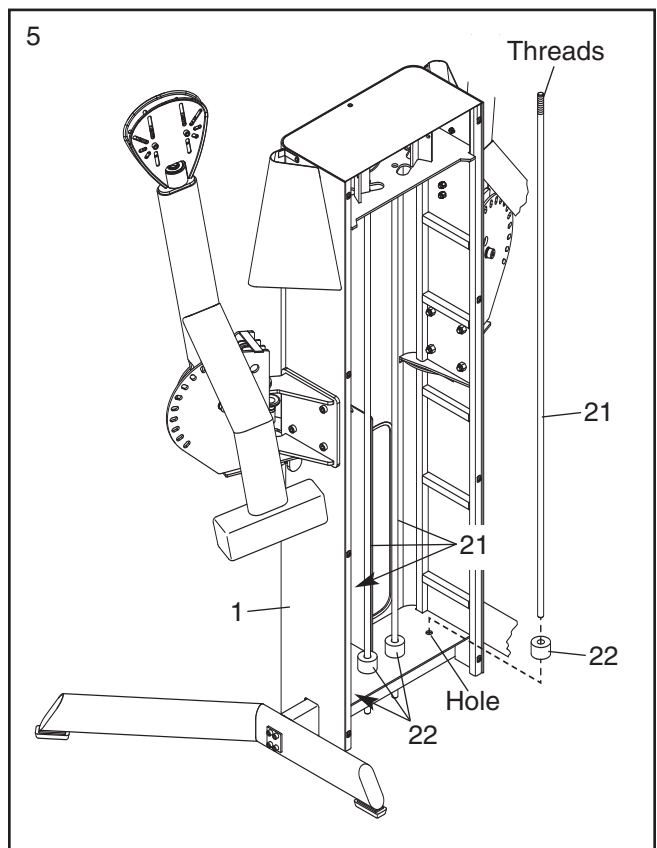



6. Orient twenty Weights (13) as shown in the upper inset drawing. Slide the Weights onto the left Weight Guide Rods (21). **Note: If there are numbered decals on the Weights, make sure to slide the Weight with the highest number onto the Weight Guide Rods first.**

Next, slide the Top Weight (15) and the Left Weight Rod (not shown) onto the left Weight Guide Rods (21).

If the Weights (13) do not have numbered decals, locate the included sheet of numbered decals. Apply a numbered decal to the Top Weight (15) and to each Weight (13) in the location shown in the lower inset drawing; **make sure to apply the decal with the lowest number to the Top Weight.**

**Repeat this step on the other side of the strength equipment.**

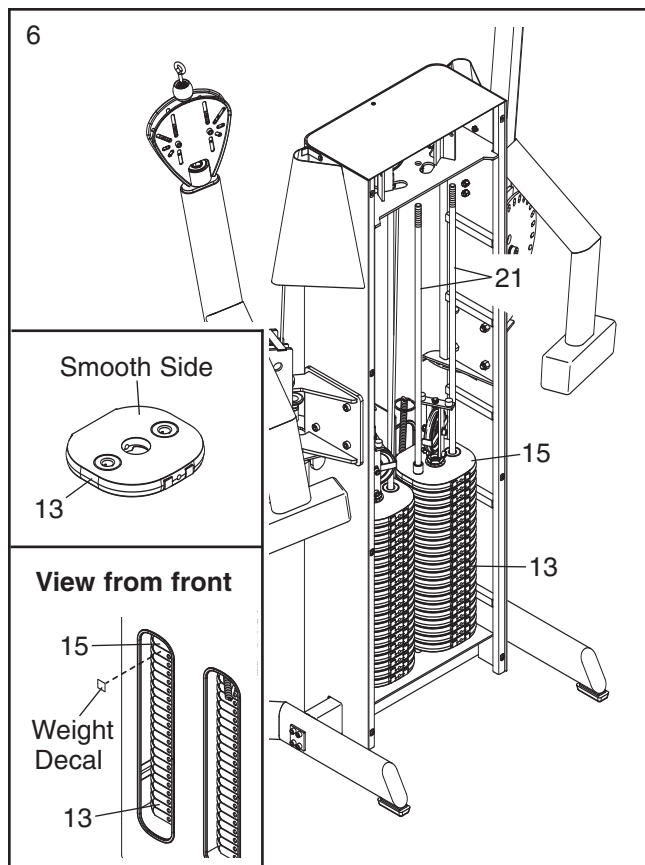

7. Tighten a 5/8" Jamnut (55) as far as possible onto a Weight Guide Rod (21), and slide a 5/8" Lock Washer (54) onto the Weight Guide Rod. Next, raise the Weight Guide Rod as far as possible into the Tower (1). Then, slide another 5/8" Lock Washer (54) onto the Weight Guide Rod (21), and tighten another the 5/8" Jamnut (55) on the Weight Guide Rod.

**Repeat this step for the remaining three Weight Guide Rods (21).**

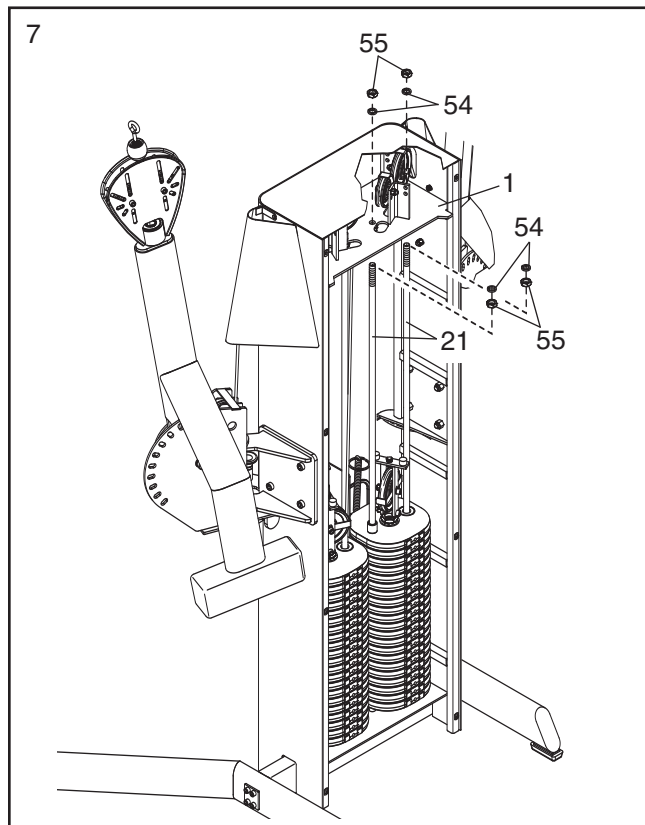

- Remove the three 1/4" Nuts (74) attaching the Left Cable Cover (12) to the strength machine. Then, remove the Left Cable Cover.

Route one of the Cables (43) into the left Swivel Bracket (8) and through the Left Arm (5) as shown. See the CABLE DIAGRAM on page 13 and route the Cable around the pulleys on the left side of the strength equipment as shown. Note: It may be helpful to loosen the nuts and bolts attaching the cable traps as you route the Cable around the pulleys. After you route the Cable, retighten the nuts and bolts. **Make sure that the cable traps are oriented as shown in the CABLE DIAGRAM on page 13; if the Cables rub against the cable traps, the Cables will become damaged.**

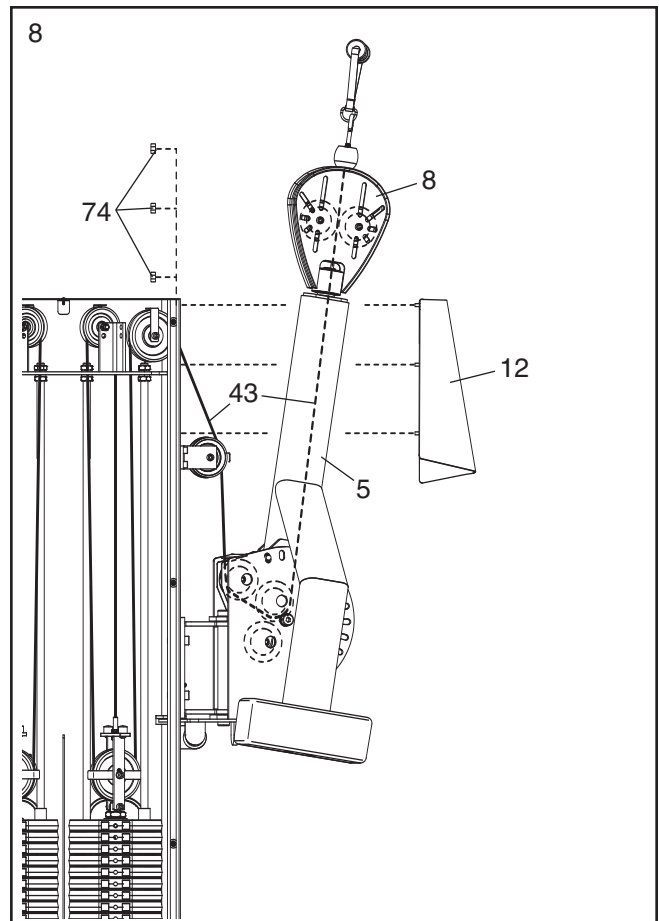

- See the inset drawing.** Tighten a 3/8" Nut (16) about halfway onto the threaded end of the Cable (43). Next, slide a 3/8" Serrated Washer (20) onto the Cable and insert the Cable into the hole in the top of the left "U"-bracket (65). Then, slide another 3/8" Serrated Washer (20) onto the Cable and tighten another 3/8" Nut (16) onto the Cable.

Reattach the Left Cable Cover (12) with the three 1/4" Nuts (74).

**Repeat step 8 and this step on the other side of the strength equipment.**

See WEIGHT GUIDE LUBRICATION on page 12 and lubricate the Weight Guide Rods (21). Then, see CABLE ADJUSTMENT on page 12 and properly tighten the Cables (43).

**See step 4. Reattach the Access Cover (2) with the eight 1/4" x 3/4" Button Screws (35).**

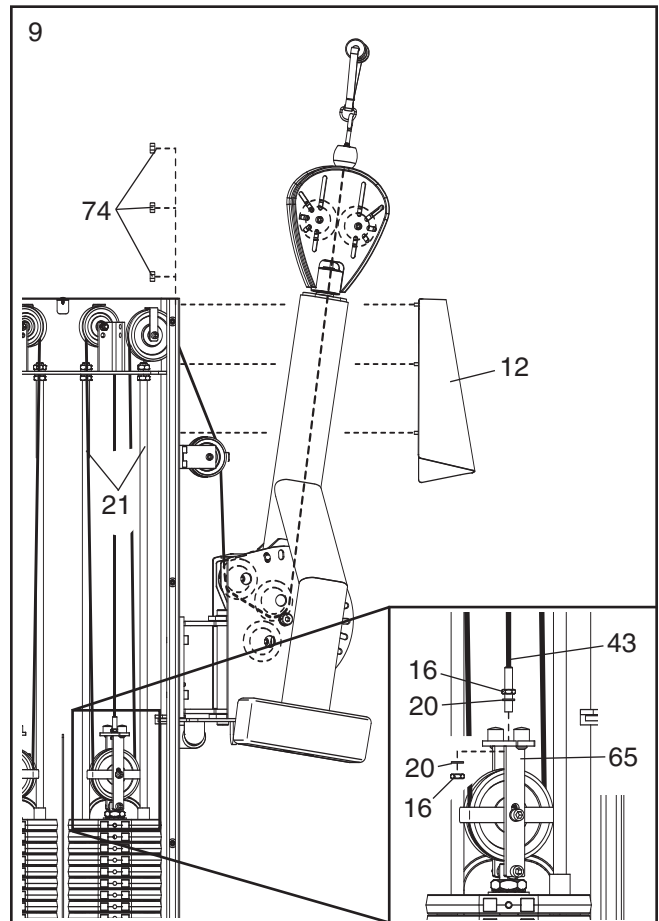

# ADJUSTMENT

This section explains how to adjust the strength equipment. See the EXERCISE GUIDELINES on page 14 for important information about how to get the most benefit from your exercise program. Also, refer to the accompanying exercise guide to see the correct form for several exercises.

## CHANGING THE WEIGHT SETTING

To change the weight setting of either weight stack, insert the Weight Pin (34) into the hole in the desired Weight (13). **Make sure that the Weight Pin is fully inserted into the Weight Rod (not shown).**

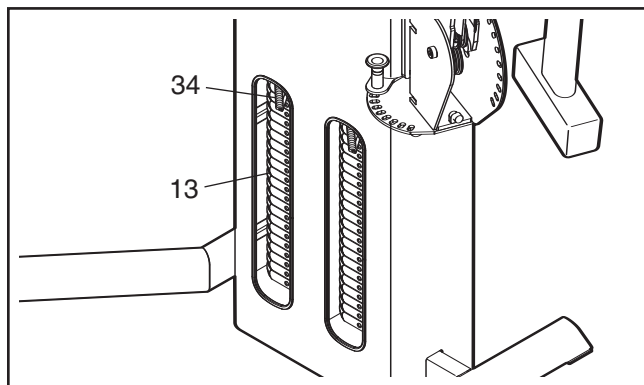

## ADJUSTING THE ARMS

To adjust the position of the Left Arm (5), pull the indicated Adjustment Knob (60), rotate the Left Arm to the desired position, and then engage the Adjustment Knob in one of the adjustment holes in the Left Arm Bracket (9). **Make sure that the Adjustment Knob is engaged in one of the adjustment holes.**

**Adjust the position of the Right Arm (6) in the same way.**

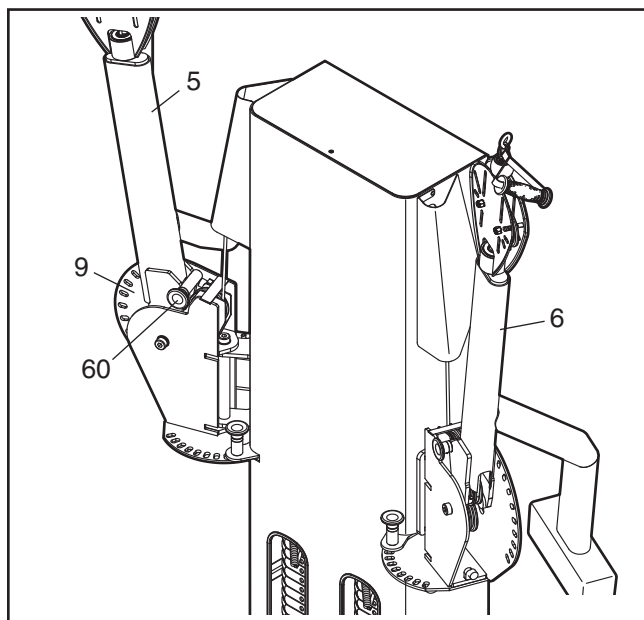

## ADJUSTING THE ARM BRACKETS

To change the position of the Left Arm Bracket (9), pull the indicated Adjustment Knob (60), move the Left Arm Bracket to the desired position, and then engage the Adjustment Knob in one of the adjustment holes in the Left Arm Bracket. **Make sure that the Adjustment Knob is fully engaged in one of the adjustment holes; the red collar on the pin should not be visible.**

**Adjust the position of the Right Arm Bracket (10) in the same way.**

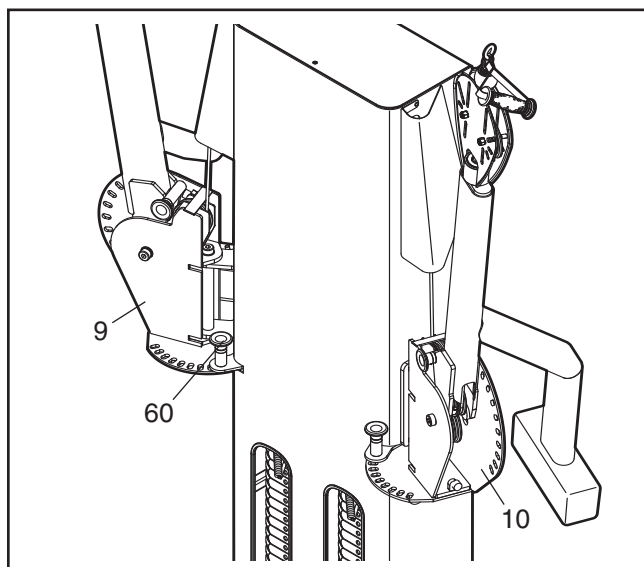

# MAINTENANCE

Make sure that all parts are properly tightened each time the strength equipment is used. Replace any worn parts immediately. Clean the strength equipment with a damp cloth and a mild, non-abrasive detergent; **do not use solvents to clean the strength equipment.**

## WEIGHT GUIDE LUBRICATION

Clean and lubricate the full length of each weight guide rod by wiping it with a soft cloth containing a light-weight motor oil, 10W-40 or 10W-30 weight. Apply only a light coating over the entire length of the weight guide rod. **Do not use TEFLON®-based lubricants.**

## CABLE INSPECTION

Check the entire length of each cable by slowly performing one repetition on the strength equipment; inspect the cable that is exposed on the exterior of the strength equipment and the cable inside the tower. Run your fingers along the cable, paying close attention at the bends and attachment points. Watch for the conditions shown at the right, which may indicate a worn cable in need of replacement.

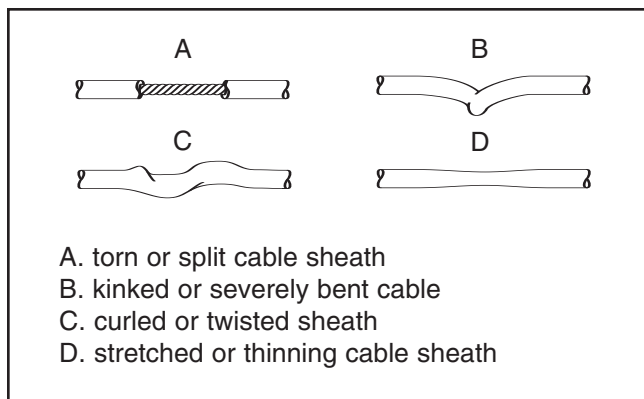

## CABLE ADJUSTMENT

Woven cable, the type of cable used on the strength equipment, can stretch slightly when it is first used. If there is slack in a cable before resistance is felt, the cable should be tightened.

To tighten either of the Cables (43), first loosen the upper 3/8" Nut (16) that connects the end of the Cable to the "U"-bracket (65). Next, tighten the lower 3/8" Nut (16) until the Cable is tight. Then, tighten the upper Nut against the "U"-bracket.

**Do not overtighten the cables. If a cable tends to slip off the pulleys often, it may have become twisted. Remove the cable and reinstall it.** If a cable needs to be replaced, please contact the authorized dealer where you purchased the strength equipment.

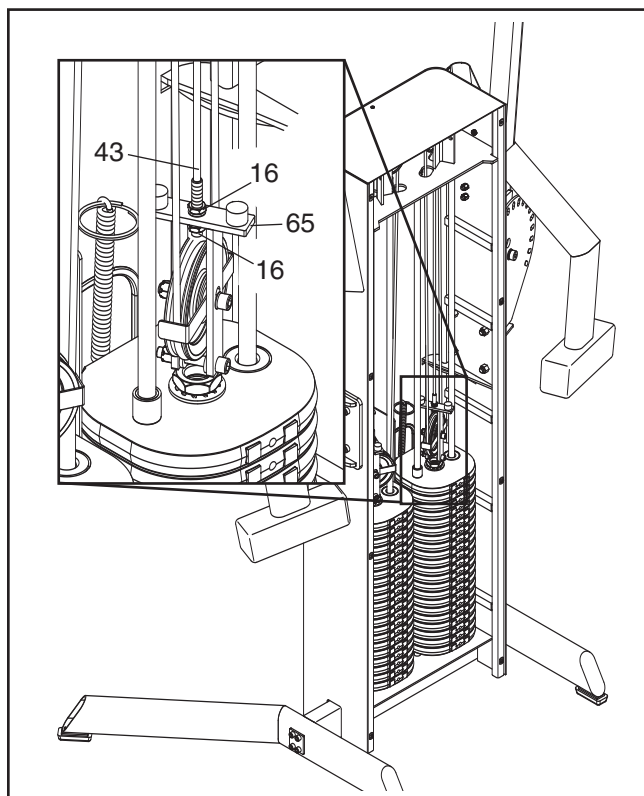

# CABLE DIAGRAM

The numbers in the diagram below show the proper routing of the cables. Use the diagram to make sure that the cables and the cable traps are assembled correctly. If the cables and the cable traps are not assembled correctly, the strength equipment will not function properly and damage may occur. **Make sure that the cable traps do not touch or bind the cables.**

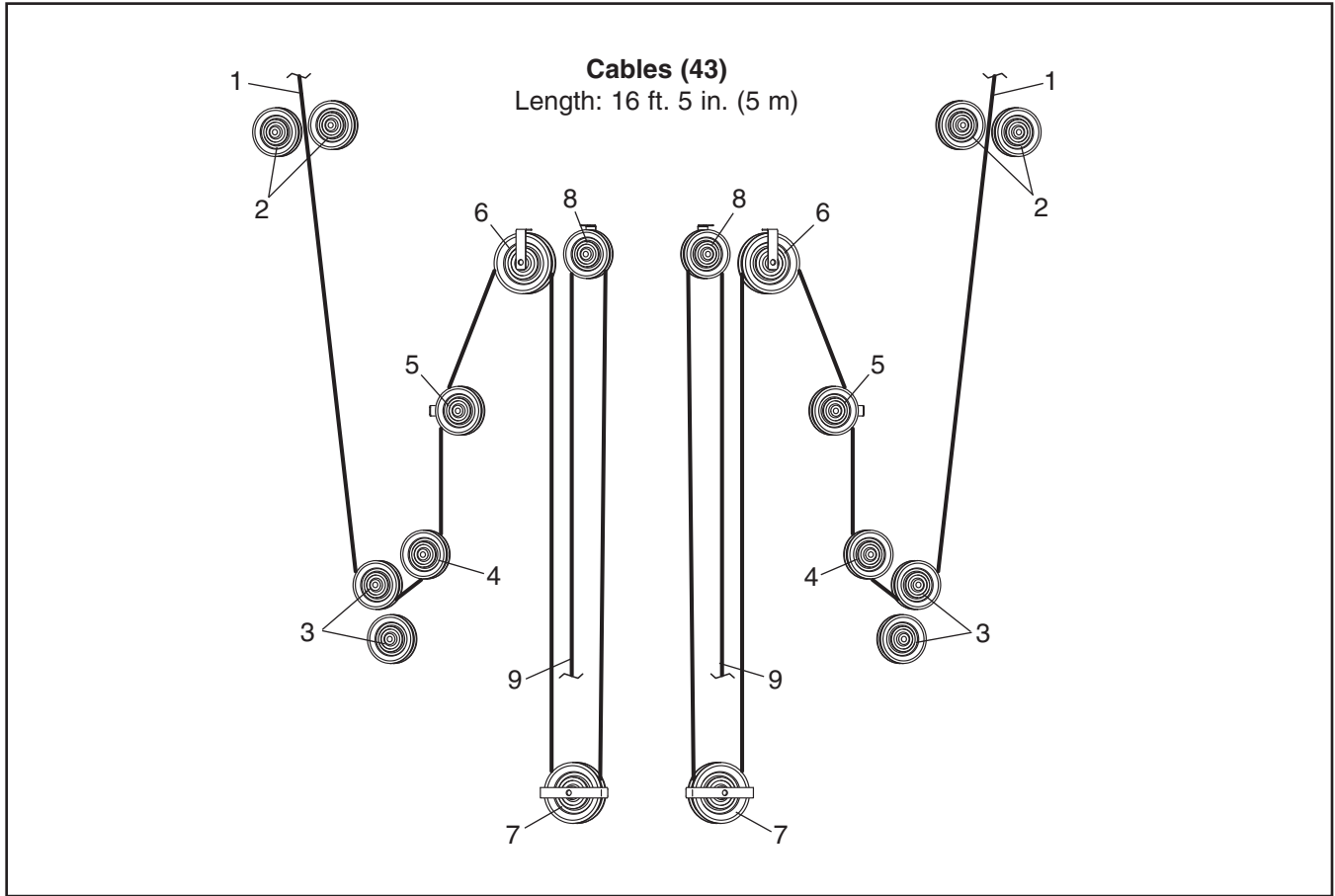

---

# EXERCISE GUIDELINES

## THE FOUR BASIC TYPES OF WORKOUTS

### Muscle Building

To increase the size and strength of your muscles, push them close to their maximum capacity. Your muscles will continually adapt and grow as you progressively increase the intensity of your exercise. You can adjust the intensity level of an individual exercise in two ways:

- by changing the amount of resistance used
- by changing the number of repetitions or sets performed. (A “repetition” is one complete cycle of an exercise, such as one sit-up. A “set” is a series of repetitions.)

The proper amount of resistance for each exercise depends upon the individual user. You must gauge your limits and select the amount of resistance that is right for you. Begin with 3 sets of 8 repetitions for each exercise you perform. Rest for 3 minutes after each set. When you can complete 3 sets of 12 repetitions without difficulty, increase the amount of resistance.

### Toning

You can tone your muscles by pushing them to a moderate percentage of their capacity. Select a moderate amount of resistance and increase the number of repetitions in each set. Complete as many sets of 15 to 20 repetitions as possible without discomfort. Rest for 1 minute after each set. Work your muscles by completing more sets rather than by using high amounts of resistance.

### Weight Loss

To lose weight, use a low amount of resistance and increase the number of repetitions in each set. Exercise for 20 to 30 minutes, resting for a maximum of 30 seconds between sets.

### Cross Training

Cross training is an efficient way to get a complete and well-balanced fitness program. An example of a balanced program follows:

- Plan strength training workouts on Monday, Wednesday, and Friday.
- Plan 20 to 30 minutes of aerobic exercise, such as running on a treadmill or riding on an elliptical exerciser or exercise cycle, on Tuesday and Thursday.
- Rest from both strength training and aerobic exercise for at least one full day each week to give your body time to regenerate.

The combination of strength training and aerobic exercise will reshape and strengthen your body, plus develop your heart and lungs.

## PERSONALIZING YOUR EXERCISE PROGRAM

Determining the appropriate length of time for each workout, and the numbers of repetitions and sets to complete, is an individual matter. Avoid overdoing it during the first few months of your exercise program. Progress at your own pace and be sensitive to your body’s signals. If you experience pain or dizziness while exercising, stop immediately and cool down. Find out what is wrong before continuing. Remember that adequate rest and a proper diet are important factors in any exercise program.

### WARMING UP

Begin each workout with 5 to 10 minutes of stretching and light exercise to warm up. Warming up prepares your body for more strenuous exercise by increasing circulation, raising your body temperature and delivering more oxygen to your muscles.

### WORKING OUT

Each workout should include 6 to 10 different exercises. Select exercises for every major muscle group, emphasizing areas that you want to develop most. To give balance and variety to your workouts, vary the exercises from workout to workout.

Schedule your workouts for the time of day when your energy level is the highest. Each workout should be followed by at least one day of rest. Once you find the schedule that is right for you, stick with it.

### EXERCISE FORM

Maintaining proper form is an essential part of an effective exercise program. This requires moving through the full range of motion for each exercise, and moving only the appropriate parts of the body. Exercising in an uncontrolled way will leave you feeling exhausted. On the exercise guide accompanying this manual you will find photographs showing the correct form for several exercises, and a list of the muscles affected. See the muscle chart on the next page to find the names of the muscles.

The repetitions in each set should be performed smoothly and without pausing. The exertion stage of each repetition should last about half as long as the return stage. Proper breathing is important. Exhale during the exertion stage of each repetition and inhale during the return stroke. Never hold your breath.

Rest for a short period of time after each set. The ideal resting periods are:

- Rest for three minutes after each set for a muscle building workout.
- Rest for one minute after each set for a toning workout.
- Rest for 30 seconds after each set for a weight loss workout.

Plan to spend the first couple of weeks familiarizing yourself with the equipment and learning the proper form for each exercise.

## COOLING DOWN

End each workout with 5 to 10 minutes of stretching. Include stretches for both your arms and legs. Move slowly as you stretch and do not bounce. Ease into each stretch gradually and go only as far as you can without strain. Stretching at the end of each workout is an effective way to increase flexibility.

## STAYING MOTIVATED

For motivation, keep a record of each workout. Write the date, the exercises performed, the resistance used, and the numbers of sets and repetitions completed. Record your weight and key body measurements at the end of every month. The key to achieving the greatest results is to make exercise a regular and enjoyable part of your everyday life.

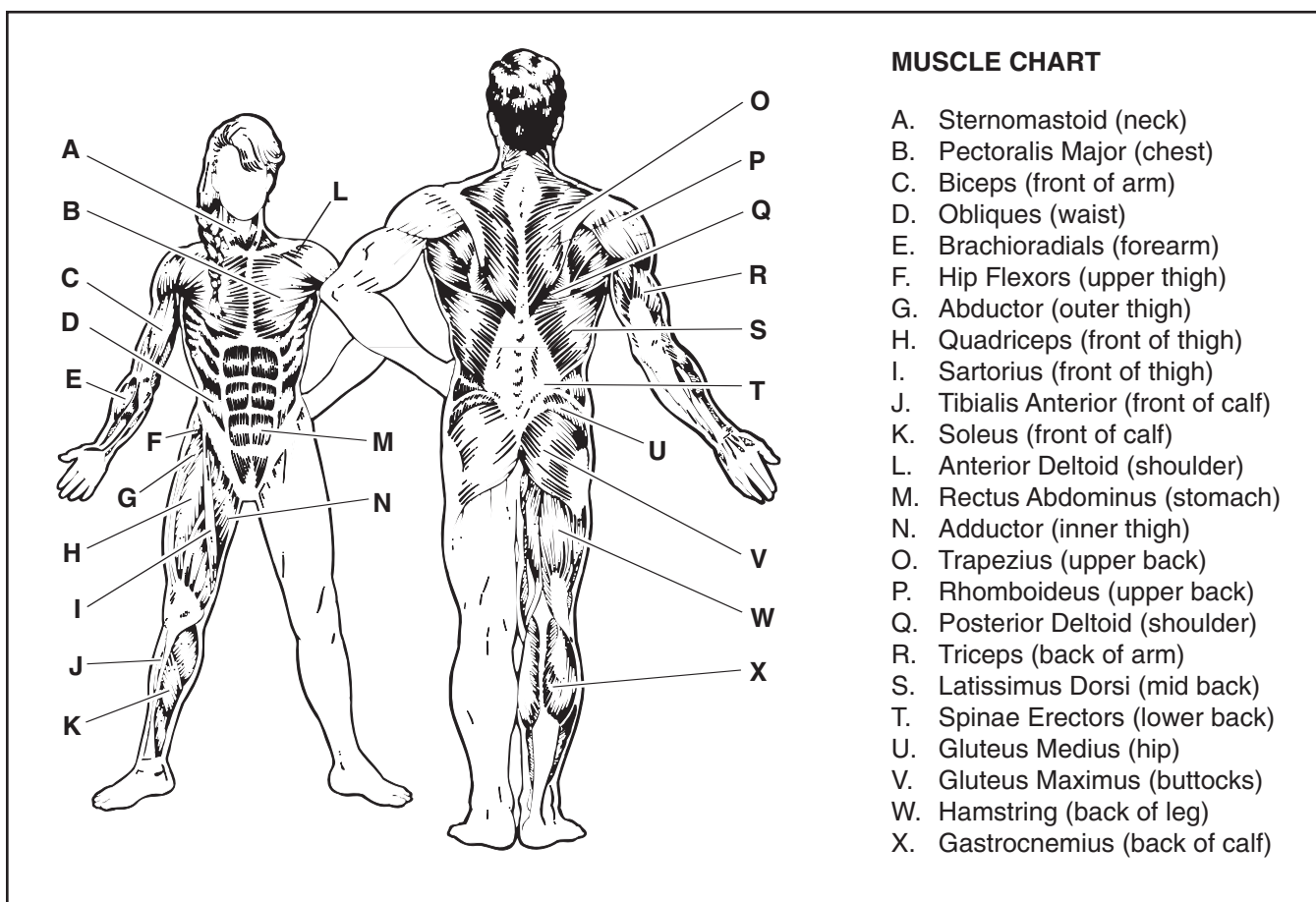

### MUSCLE CHART

- A. Sternomastoid (neck)
- B. Pectoralis Major (chest)
- C. Biceps (front of arm)
- D. Obliques (waist)
- E. Brachioradials (forearm)
- F. Hip Flexors (upper thigh)
- G. Abductor (outer thigh)
- H. Quadriceps (front of thigh)
- I. Sartorius (front of thigh)
- J. Tibialis Anterior (front of calf)
- K. Soleus (front of calf)
- L. Anterior Deltoid (shoulder)
- M. Rectus Abdominus (stomach)
- N. Adductor (inner thigh)
- O. Trapezius (upper back)
- P. Rhomboideus (upper back)
- Q. Posterior Deltoid (shoulder)
- R. Triceps (back of arm)
- S. Latissimus Dorsi (mid back)
- T. Spinae Erectors (lower back)
- U. Gluteus Medius (hip)
- V. Gluteus Maximus (buttocks)
- W. Hamstring (back of leg)
- X. Gastrocnemius (back of calf)

---

# LIMITED WARRANTY

FreeMotion Fitness warrants this product to be free from defects in workmanship and material under normal use and service conditions. The warranty period commences on the invoice date of purchase. Any parts repaired or replaced during this warranty period will be warranted for the remainder of the original warranty period.

## WARRANTY PERIODS AND COVERAGE

Residential and Light Commercial

Frame: Lifetime

Parts: 10 years

Cables/Belts: 1 year

Upholstery and Accessories: 90 days

Labor: 1 year

Light commercial use is defined as a non-dues-paying institutional setting to include hotels, apartment fitness centers, corporate fitness centers, fire/police stations, and hospital/physical therapy settings. This product is not intended to be used in large, heavy-use settings such as health clubs, colleges/universities, community centers, or military installations. Use of this product in such facilities will void this warranty.

## CONDITIONS AND LIMITATIONS

The following will void the warranty on this product:

1. This warranty applies only to the original owner and is non-transferable.
2. The 1-year labor warranty applies only to products sold in the US and Canada. Contact your authorized FreeMotion Fitness dealer for details on labor coverage in your country.
3. Any misuse, abuse, or improper service.
4. Users in excess of 350 lbs. (159 kg) in weight.
5. Damage caused by moving the product or improper storage including moving or storing the product on its side.
6. Use or storage of the product outdoors or in high-humidity environments including spas and pools.

This warranty shall not apply to the following:

1. Cosmetic items including grips, decals, and labels.
2. Pick-up and delivery or freight charges involved with a repair.
3. Any problem as a result of improper assembly or delivery.

## WHAT TO DO IF SERVICE IS REQUIRED

FreeMotion Fitness warranty service may be obtained by contacting the authorized dealer from which you purchased your equipment. Make sure to retain your original invoice and serial number information. If this product experiences a failure under the warranty terms set forth, FreeMotion Fitness shall provide at their option either repair, replacement, or refund of the purchase price. FreeMotion Fitness compensates service providers for warranty trips within their service area. You may be charged additionally for service calls beyond this service area.

FreeMotion Fitness is not responsible or liable for indirect, special or consequential damages arising out of or in connection with the use or performance of the product or damages with respect to any economic loss, loss of property, loss of revenues or profits, loss of enjoyment or use, cost of removal, installation or other consequential damages. Some states do not allow the exclusion or limitation of consequential damages. Accordingly, the above limitation may not apply to you. This warranty gives you specific rights and you may have other rights that vary from state to state.

## TO CONTACT FREEMOTION FITNESS

See HOW TO CONTACT CUSTOMER CARE on the back cover of this manual.



# PART LIST—Model No. VFMCS4007.0

R1107A

If replacement parts are needed, or if parts are missing or damaged, see HOW TO CONTACT CUSTOMER CARE on the back cover of this manual.

Key No.	Qty.	Description	Key No.	Qty.	Description
1	1	Tower	42	8	3/4" x 1/2" Shoulder Bolt
2	1	Access Cover	43	2	Cable
3	1	Right Leg	44	2	Plastic Cover
4	1	Left Leg	45	8	1/4"-20-unc Set Screw
5	1	Left Arm	46	2	Coupler
6	1	Right Arm	47	10	3/8"-16 Jamnut
7	2	Counterweight	48	2	Cable Bearing
8	2	Swivel Bracket	49	2	Eyebolt
9	1	Left Arm Bracket	50	6	3/8" x 1" Bolt
10	1	Right Arm Bracket	51	2	1" Nut
11	4	3/8" x 4 1/2" Screw	52	2	1" Thick Washer
12	1	Left Cable Cover	53	4	3/8" x 2 1/4" Bolt
13	40	Weight	54	8	5/8" Lock Washer
14	1	Left Weight Rod	55	8	5/8" Jamnut
15	2	Top Weight	56	8	1/2" Nylon Locknut
16	4	3/8" Nut	57	2	Small Adjustment Pin
17	6	3/8" x 1 1/2" Button Head Bolt	58	2	Star Washer
18	1	Tower Cover	59	2	Pivot
19	4	Leg Bumper	60	4	Adjustment Knob
20	8	3/8" Serrated Washer	61	2	Large Single Cable Trap
21	4	Weight Guide Rod	62	4	Spring
22	4	Weight Bumper	63	1	Right Weight Rod
23	8	Top Weight Bumper	64	1	Right Cable Cover
24	4	Guide Bushing	65	2	"U"-bracket
25	4	Arm Bumper	66	1	#8 Screw
26	2	Trunnion	67	4	3/8" Nylon Washer
27	14	3 1/2" Pulley	68	82	Weight Bushing
28	2	Retainer Ring	69	2	Double Cable Trap
29	4	4 1/2" Pulley	70	8	3/8" x 3" Bolt
30	8	5/16" Screw	71	2	1 1/8" Internal Retainer Ring
31	4	Pivot Pulley Bearing	72	4	3" Single Cable Trap
32	2	1" Thin Washer	73	20	3/8" Nylon Locknut
33	2	1" Wave Washer	74	6	1/4" Nut
34	2	Weight Pin	75	2	Handle
35	16	1/4" x 3/4" Screw	76	2	Large Adjustment Pin
36	4	Adjustment Pin Cap	77	2	Trim
37	6	3/8" x 1 3/4" Bolt	78	2	3/8" Washer
38	6	3/8" x 2" Bolt	*	—	User's Manual
39	2	Pulley Bracket	*	—	Exercise Guide
40	8	3/4" Bushing	*	—	Weight Decal Sheet
41	8	1/2" x 1 1/2" Socket Head Screw	*	—	Ankle Strap

Note: Specifications are subject to change without notice. See the back cover of this manual for information about ordering replacement parts. \*These parts are not illustrated.

# EXPLODED DRAWING A—Model No. VFMCS4007.0

R1107A

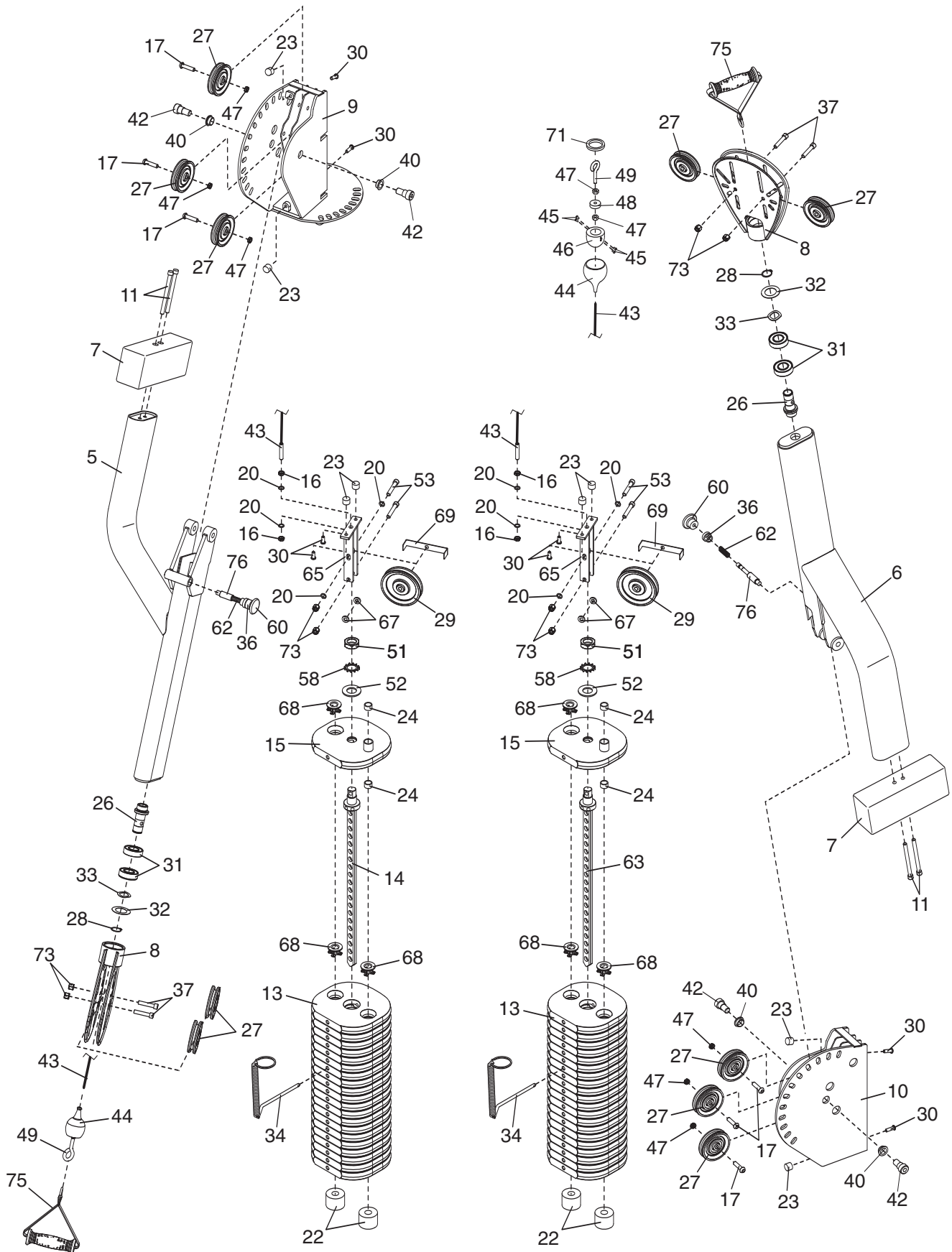

# EXPLODED DRAWING B—Model No. VFMCS4007.0

R1107A

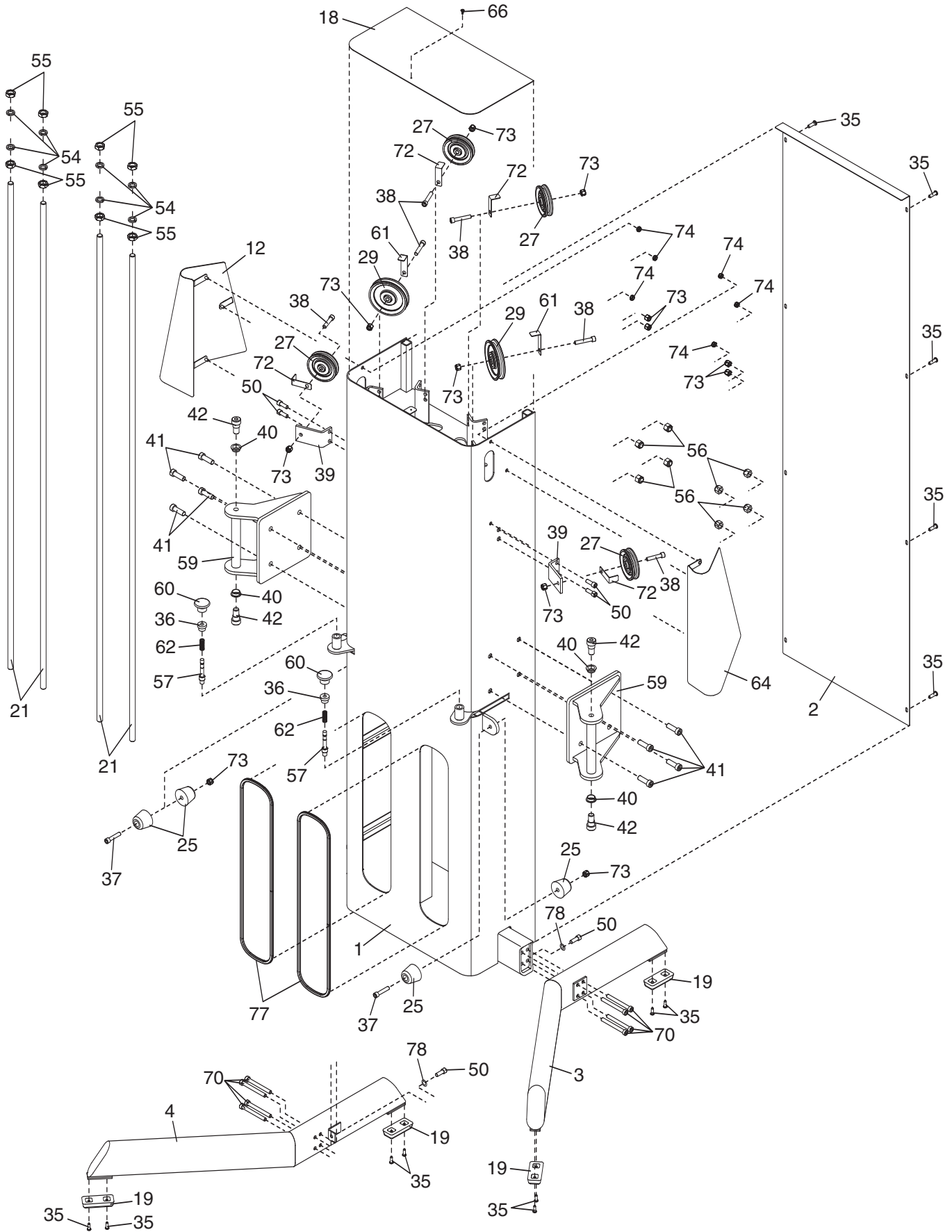

---

# HOW TO CONTACT CUSTOMER CARE

If you have questions after reading this manual, if you require assistance, or if you need to order replacement parts, please contact Customer Care at the address or phone number listed below. Please be prepared to provide the following information:

- the model number and serial number of the product (see the front cover of this manual)
- the name of the product (see the front cover of this manual)

When ordering replacement parts, please also provide the KEY NUMBER and DESCRIPTION of the part(s) (see the PART LIST and the EXPLODED DRAWING near the end of this manual).

## **Call**

Toll-free in the US: 1-866-799-8946, Mon.–Fri. 8 am–5 pm MST

International: +1-719-533-2911

## **Email**

US: [fmvcustomerservice@freemotionfitness.com](mailto:fmvcustomerservice@freemotionfitness.com)

International: [intlcustomercare@freemotionfitness.com](mailto:intlcustomercare@freemotionfitness.com)

## **Write**

FreeMotion Fitness

1096 Elkton Drive Suite 600

Colorado Springs, CO 80907