

Recline Excite

SERVICE & MAINTENANCE MANUAL

REV. 1.3



The information contained in this manual is intended for **QUALIFIED TECHNICIANS** who have completed a specific **TECHNOGYM** training course and are authorized to perform machine start-up and adjustment procedures as well as extraordinary maintenance or repairs which require a thorough knowledge of the machine, its operation, its safety devices and working procedures.

**CAREFULLY READ THE INFORMATION CONTAINED IN
THIS MANUAL BEFORE PERFORMING ANY MAINTENANCE
PROCEDURES ON THE MACHINE**



**DANGEROUS VOLTAGES
PRESENT**

NOTE

The information contained in this document is subject to change without notice.

Technogym does not guarantee this documentation in any way. Technogym shall not be held responsible for any errors contained in this manual and declines all liability for accidents or damages resulting from the supply, characteristics or use of this manual.

This document contains proprietary information that is protected by copyright. All rights reserved. No part of this document may be photocopied, reproduced or translated into another language without the prior written consent of Technogym.

The Technogym™ trademark is property of Technogym S.p.A.
The Recline Excite™ trademark is property of Technogym S.p.A.



Contents

1. GENERAL NOTICES	1.1
1.1. INTRODUCTION.....	1.1
1.2. RECOMMENDATIONS	1.1
1.3. GENERAL RULES FOR REPAIR PROCEDURES	1.2
2. TECHNICAL CHARACTERISTICS	2.1
2.1. AVAILABLE VERSIONS	2.1
2.2. MECHANICAL CHARACTERISTICS	2.1
2.3. ELECTRICAL CHARACTERISTICS	2.2
2.4. AMBIENT SPECIFICATIONS	2.2
2.5. CONFORMITY TO REGULATIONS.....	2.2
2.6. PRODUCT CODES.....	2.3
2.7. WIRING DIAGRAM	2.5
2.7.1. 500 model.....	2.5
2.7.1.1. Powered version.....	2.5
2.7.1.2. Cordless version.....	2.6
2.7.2. 700 model.....	2.7
2.7.2.1. Powered version.....	2.7
2.7.2.2. Cordless version.....	2.8
2.7.2.3. Wellness TV version.....	2.9
2.8. CABLES	2.10
3. PRINCIPLES OF OPERATION	3.1
3.1. BLOCK DIAGRAM.....	3.1
3.1.1. Display boards	3.2
3.1.1.1. 500 and 500SP models.....	3.2
3.1.1.2. 700 and 700SP models.....	3.3
3.1.1.3. 700E model (Wellness TV)	3.4
3.1.2. CSafe Board	3.6
3.1.3. TGS/Smart Card Board.....	3.6
3.1.4. Hand sensor board.....	3.6
3.1.5. Cardio receiver.....	3.6
3.1.6. Connectors panel.....	3.7
3.1.7. Brake board.....	3.7
3.1.8. Brake	3.7
3.1.9. Speed sensor.....	3.8
3.1.10. Power entry module.....	3.8
3.1.11. Alternator	3.8
3.1.12. Battery.....	3.8
3.1.13. External power supply input.....	3.9
3.2. BRAKE CONTROL	3.10
3.2.1. Mechanics.....	3.10
3.2.2. Control	3.10
3.2.3. The signals involved	3.11
4. ACCESSORIES	4.1
4.1. CARDIO THEATER CONNECTION	4.1
4.2. PC LINK FOR PROGRAMMING.....	4.1
4.3. PROGRAMMING PLUG FOR CSAFEBOARD	4.2
4.4. CABLE FOR EXCHANGING TV CHANNEL TUNING DATA BETWEEN TWO MACHINES	4.2
4.5. MONITOR PLUG FOR CSAFEBOARD	4.3
4.6. WELLNESS TV UPGRADE KIT.....	4.4
4.6.1. Installation procedure	4.5
5. INSTALLATION INSTRUCTIONS	5.1

5.1. SPECIFICATIONS AND REQUIREMENTS	5.1
5.2. SPECIFICATIONS AND REQUIREMENTS TO INSTALL A WELLNESS TV MACHINE.....	5.1
5.3. INSTALLATION.....	5.2
5.4. FIRST POWER-ON	5.2
6. TROUBLESHOOTING	6.1
6.1. SERVICE TROUBLESHOOTING MENU FOR 700 MODELS	6.2
6.1.1. <i>Automatic Test</i>	6.3
6.1.1.1. I2C Devices Test.....	6.3
6.1.1.2. LED Test (not on 700E models).....	6.3
6.1.1.3. Serial Ports Test	6.3
6.1.1.4. Test Result	6.3
6.1.1.5. Reset Result	6.4
6.1.2. <i>Manual Test</i>	6.4
6.1.2.1. Man. Keyboard Test.....	6.4
6.2. SERVICE TROUBLESHOOTING MENU FOR 500 MODELS	6.5
6.2.1. <i>Automatic Test</i>	6.6
6.2.1.1. I2C Devices Test.....	6.6
6.2.1.2. LED Test.....	6.6
6.2.1.3. Serial Ports Test	6.6
6.2.1.4. Test Result	6.6
6.2.1.5. Reset Result	6.7
6.2.2. <i>Manual Test</i>	6.7
6.2.2.1. Man. Keyboard Test.....	6.7
6.3. THE DISPLAY FAILS TO ILLUMINATE	6.8
6.3.1. <i>500 and 700 models</i>	6.8
6.3.2. <i>500SP and 700SP models</i>	6.11
6.3.3. <i>700E Wellness TV models</i>	6.14
6.4. NO AUDIO SOUND	6.18
6.5. NO TV PICTURE	6.19
6.6. THE RADIO DOES NOT PLAY	6.21
6.7. “THE EQUIPMENT IS BLOCKED” MESSAGE ON THE DISPLAY	6.23
6.8. ERROR DETECTED BY BRAKE BOARD	6.24
6.8.1. <i>Error 1 on brake board</i>	6.24
6.8.2. <i>Error 2 on brake board</i>	6.24
6.8.3. <i>Error 4 on brake board</i>	6.24
6.8.4. <i>Error 8 on the brake board</i>	6.25
6.8.5. <i>Error 16 or 32 on the brake board</i>	6.25
6.8.6. <i>Error 128 on brake board</i>	6.25
6.9. THERE IS NO RESISTANCE	6.26
6.10. THE RESISTANCE IS INCORRECT	6.27
6.11. THE SPEED SIGNAL IS INCORRECT	6.29
6.12. THE MACHINE DOES NOT READ THE TGS/SMART CARD.....	6.30
6.13. THERE IS NO HEART RATE SIGNAL.....	6.32
6.13.1. <i>Ricevitore telemetrico HFU</i>	6.32
6.13.2. <i>OwnZone telemetric receiver</i>	6.32
6.13.3. <i>Hand sensor</i>	6.34
6.14. THE TELEMETRIC HR SIGNAL IS INCORRECT	6.35
7. DISASSEMBLY OF COMPONENTS.....	7.1
7.1. DISASSEMBLING THE DISPLAY	7.1
7.1.1. <i>700 and 700SP LED versions</i>	7.1
7.1.2. <i>700E Wellness TV version</i>	7.3
7.1.3. <i>500 and 500SP LED versions</i>	7.5
7.2. DISASSEMBLING THE CIRCUIT BOARDS ON THE DISPLAY.....	7.7
7.2.1. <i>700 and 700SP LED versions</i>	7.7
7.2.2. <i>700E Wellness TV version</i>	7.9
7.2.3. <i>500 and 500SP LED versions</i>	7.13
7.3. DISASSEMBLING THE KEYBOARD.....	7.14
7.3.1. <i>700 and 700SP LED versions</i>	7.14
7.3.2. <i>700E Wellness TV version</i>	7.15



7.3.3. 500 and 500SP LED versions.....	7.17
7.4. DISASSEMBLING THE CARDIO RECEIVER	7.18
7.5. DISASSEMBLING THE SENSORS	7.19
7.6. DISASSEMBLING THE PEDALS AND THE PEDAL CRANKS	7.20
7.7. DISASSEMBLING THE GUARDS	7.21
7.8. DISASSEMBLING THE ELECTRICAL BOX.....	7.22
7.9. DISASSEMBLING THE BELT	7.23
7.10. DISASSEMBLING THE PULLEY	7.24
7.11. DISASSEMBLING THE BRAKE WINDING.....	7.25
7.12. DISASSEMBLING THE BRAKE GROUP	7.26
7.13. DISASSEMBLING THE SPEED SENSOR.....	7.28
7.14. DISASSEMBLING THE PLATFORMS WITH CSAFE BOARD CONNECTORS AND POWER ENTRY MODULE.....	7.29
7.15. DISASSEMBLING THE ALTERNATOR	7.31
7.16. DISASSEMBLING THE BATTERY	7.32
7.17. DISASSEMBLING THE SADDLE.....	7.33
7.18. DISASSEMBLING THE HAND SENSOR BOARD	7.36
7.19. DISASSEMBLING THE SADDLE HANDLEBARS.....	7.38
8. ADJUSTMENTS.....	8.1
8.1. BELT TENSION	8.1
8.2. SPEED SENSOR POSITION.....	8.2
8.3. BRAKE ASSEMBLY	8.3
8.4. SADDLE SLIDING.....	8.4
9. MACHINE CONFIGURATION.....	9.1
9.1. USER MENU CONFIGURATION FOR 700 MODELS.....	9.1
9.1.1. Language	9.1
9.1.2. Distance.....	9.2
9.1.3. Priority setting.....	9.2
9.1.4. Maximum exercise time	9.2
9.1.5. Pause time	9.3
9.1.6. Enable TGS	9.3
9.1.7. Enable keyboard.....	9.3
9.1.8. Modifiable target heart rate	9.4
9.1.9. Enable custom messages	9.4
9.1.10. Edit custom messages.....	9.4
9.1.11. Enable multi-language mode.....	9.4
9.1.12. Resetting parameters to default values.....	9.5
9.1.13. Format P&P.....	9.5
9.2. USER MENU CONFIGURATION FOR 500 MODEL	9.6
9.2.1. Language.....	9.6
9.2.2. Distance.....	9.7
9.2.3. Maximum exercise time	9.7
9.2.4. Pause time	9.7
9.2.5. Default age	9.8
9.2.6. Default weight	9.8
9.2.7. Default time	9.8
9.2.8. Default calories.....	9.9
9.2.9. Default distance.....	9.9
9.2.10. Enable TGS	9.9
9.2.11. Enable keyboard.....	9.10
9.2.12. Modifiable target heart rate	9.10
9.2.13. Enable custom messages	9.10
9.2.14. Resetting parameters to default values.....	9.11
9.2.15. Format P&P.....	9.11
9.3. SERVICE MENU CONFIGURATION	9.12
9.3.1. Time and date	9.13
9.3.1.1. Hour	9.14
9.3.1.2. Minutes.....	9.14

9.3.1.3. Day	9.14
9.3.1.4. Month	9.14
9.3.1.5. Year	9.14
9.3.1.6. Set Clock	9.14
9.3.2. <i>Low kit parameter</i>	9.14
9.3.2.1. Read from low kit	9.15
9.3.2.2. Write to low kit	9.15
9.3.2.3. Default Setting	9.15
9.3.2.4. Configuration parameters table	9.15
9.3.3. <i>Operating data</i>	9.16
9.3.3.1. Read from low kit	9.16
9.3.3.2. Write to low kit	9.16
9.3.3.3. Machine usage data	9.16
9.3.4. <i>Errors log</i>	9.17
9.3.4.1. Read from low kit	9.17
9.3.4.2. Reset Errors	9.18
9.3.4.3. View Errors	9.18
9.3.5. <i>Standard settings</i>	9.18
9.3.6. <i>Low kit menu</i>	9.19
9.3.6.1. Low kit version	9.19
9.3.6.2. Low Kit fault code	9.19
9.3.7. <i>High kit version</i>	9.20
9.3.8. <i>TV Standard (700E version only)</i>	9.20
9.4. TV MENU CONFIGURATION FOR 700E MODEL	9.21
9.4.1. <i>TV channel tuning</i>	9.21
9.4.2. <i>Wellness TV adjustments</i>	9.22
9.5. RADIO MENU CONFIGURATION FOR 700E MODEL	9.23
9.5.1. <i>Radio channel tuning</i>	9.23
9.6. TRANSFERRING THE TUNING DATA	9.24
9.6.1. <i>Using the TGS</i>	9.24
9.6.2. <i>Using the connecting cable</i>	9.24
10. SCHEDULED MAINTENANCE	10.1
10.1. DAILY MAINTENANCE OPERATIONS	10.1
10.1.1. <i>Setting up the operation</i>	10.1
10.1.2. <i>External cleaning operations</i>	10.1
10.2. MONTHLY MAINTENANCE OPERATIONS	10.2
10.2.1. <i>Saddle cleaning operation</i>	10.2
10.2.2. <i>Check wear of foot straps</i>	10.2
10.2.3. <i>Checking the operation of the cardiometer receiver</i>	10.2
10.2.4. <i>Checking the operation of the hand sensor receiver</i>	10.2
10.3. TWICE-YEARLY MAINTENANCE OPERATIONS	10.3
10.3.1. <i>Carrying out the monthly maintenance procedure</i>	10.3
10.3.2. <i>Setting up the operation</i>	10.3
10.3.3. <i>Cleaning operations</i>	10.3
10.3.4. <i>Checking the working conditions</i>	10.3
10.3.5. <i>Checking the wear of rubber parts</i>	10.3
10.3.6. <i>Checking the belt</i>	10.3
10.3.7. <i>Checking the display</i>	10.3
10.3.8. <i>Checking the wiring and connections</i>	10.4
11. APPENDIX	11.1
11.1. UPDATING THE SW	11.1
11.2. COMPATIBILITY BETWEEN HW AND SW	11.1
11.2.1. <i>CPU HW version for Wellness TV</i>	11.1
11.3. REQUIRED TOOLS	11.2

1. GENERAL NOTICES

1.1. INTRODUCTION

This document is reserved for Technogym Service technicians, and is intended to provide authorized personnel with the necessary information to correctly carry out repairs and maintenance. A thorough knowledge of the technical information contained in this manual is essential for completing the professional training of the operator.

In order to facilitate consultation, the paragraphs are accompanied by schematic drawings which illustrate the procedure being described.

This manual contains notices and symbols which have a specific meanings:



WARNING: non observance may result in accident or injury.



ATTENTION: non observance may cause damage to the machine.



Information about the operation in progress.



OBSERVE: observation about the operation in progress.

1.2. RECOMMENDATIONS

Technogym recommends the following steps for planning repair procedures:

- Carefully evaluate the customer's description of the machine malfunction and ask all the necessary questions to clarify the symptoms of the problem.
- Clearly diagnose the causes of the problem. This manual provides the fundamental theoretical basis, which must then be integrated by personal experience and attendance at the training courses periodically offered by Technogym.
- Rationally plan the repair procedure so as to minimize the downtime necessary for procuring spare parts, preparing tools, etc.
- Access the component to be repaired, avoiding any unnecessary operations. In this regard it will be useful to refer to the disassembly sequence described in this manual.

1.3. GENERAL RULES FOR REPAIR PROCEDURES

1. Always mark any parts or positions which may be confused with each other at the time of reassembly.
2. Use original Technogym spare parts and lubricants of the recommended brands.
3. Use special tools where specified.
4. Consult the Technical Newsletters, which may contain more up-to-date information on adjustments and maintenance than those contained in this manual.
5. Before starting the repair procedure, make sure that the recommended tools are available and in good condition.
6. For the procedures described in this manual, use only the specified tools.

 OBSERVE: The tool sizes quoted in this manual are expressed in mm.

2. TECHNICAL CHARACTERISTICS

2.1. AVAILABLE VERSIONS

There machine is available in 5 versions:

- Recline 500: mains operated machine
- Recline 500SP: self-powered machine
- Recline 700: mains operated machine
- Recline 700SP: self-powered machine
- Recline 700E: mains operated machine with Wellness TV display

all of which have the same structure but are differentiated by certain characteristics.

		VERSION			
		500	500 SP	700 – 700E	700 SP
CHARACTERISTIC	Power	30-500 Watt	40-500 Watt	30-500 Watt	40-500 Watt
	Hand sensor	NO		YES	
	CSafe	YES		YES	
	Cardio receiver	HFU		OwnZone	
	Training programs	Quick start Goal CPR		Quick start Goal 6 profiles CPR Weight Loss OwnZone Custom program	
	Test functions	Fitness test		Fitness test	

2.2. MECHANICAL CHARACTERISTICS

	VERSION	
	500SP - 700SP	500 – 700 – 700E
Width	57 cm - 22.4 in	
Length	143 cm - 56.3 in	
Height	138.5 cm - 54.5 in	
Weight	88 Kg - 194 lbs	88 Kg - 194 lbs

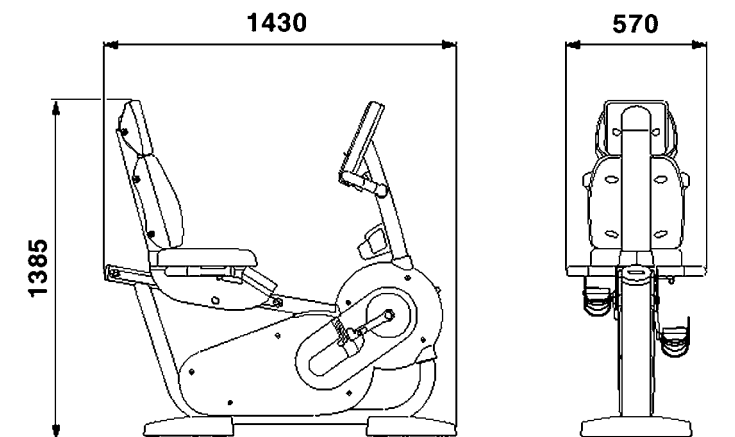

2.3. ELECTRICAL CHARACTERISTICS

	VERSION	
	500	700 - 700E
Mains voltage	90 - 260 VAC	
Frequency	50 - 60 Hz	
Consumption	50 VA	
Fuses	F 3.15 A	

2.4. AMBIENT SPECIFICATIONS

Temperature	Operating	from 5° to 35° C
	Storage	from -10° to 70° C
Humidity	Operating	from 30% to 80% non-condensing
	Storage	from 5% to 85% non-condensing

2.5. CONFORMITY TO REGULATIONS

The machine conforms to the following standards:

	Europe	USA
EMI	EN 55014-1 EN 55014-2 EN 61000-3-2 EN 61000-3-3	UL 1647
Safety	EN 60335-1 EN 957-1 EN 957-5 class SA	
Directives	73/23/CEE 89/366/CEE 89/392/CEE	

In addition:

- Electrical isolation class: **Class I**;
- Protection rating: **IP21**.

2.6. PRODUCT CODES

The machine codes take into account all the possible variants and options available for the products. The machine code, which does not include the Serial Number, consists of 16 alphanumeric characters arranged as follows:

Characters	description	key to values
1,2,3	Machine type: Recline Excite	D46
4	Product version	5 = Recline 500 7 = Recline 700
5	Type of power supply	3 = multi-voltage (110-220) 4 = self-powered
6	Type of display	L = LED display T = Wellness TV
7	Device for downloading data used by the Wellness System	N = not available T = TGS S = smart card
8, 9	Color of the frame	AL = aluminum
10, 11	Color of paddings	AG = gray M0 = bordeaux
12	Guard color	G = gray
13	Type of TV model	0 = none E = 1, 2, 5, 6, 8, 9, A U = 3, 4, 7, B Where: 1 = Pal B/G 2 = Pal I 3 = Pal N 4 = NTSC M 5 = Secam E/L 6 = Secam D/K 7 = NTSC M44 8 = Pal D/K 9 = Secam B/G A = Secam K1 B = Pal M

Characters	description	key to values
14,15	Language	IT = Italian DE = German FR = French US = American English NL = Dutch BR = Portuguese JP = Japanese UK = British English ES = Spanish
16	Type of packaging	I = Italy E = standard international S = overseas international 0 = none

For example, a possible product code would be:

D4673LTALM0G0UKE

which is interpreted as follows:

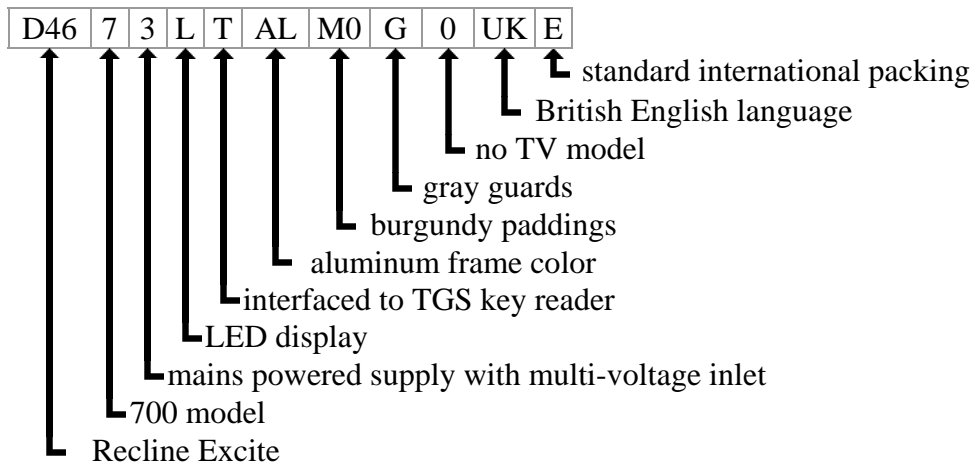

2.7. WIRING DIAGRAM

2.7.1. 500 MODEL

2.7.1.1. Powered version

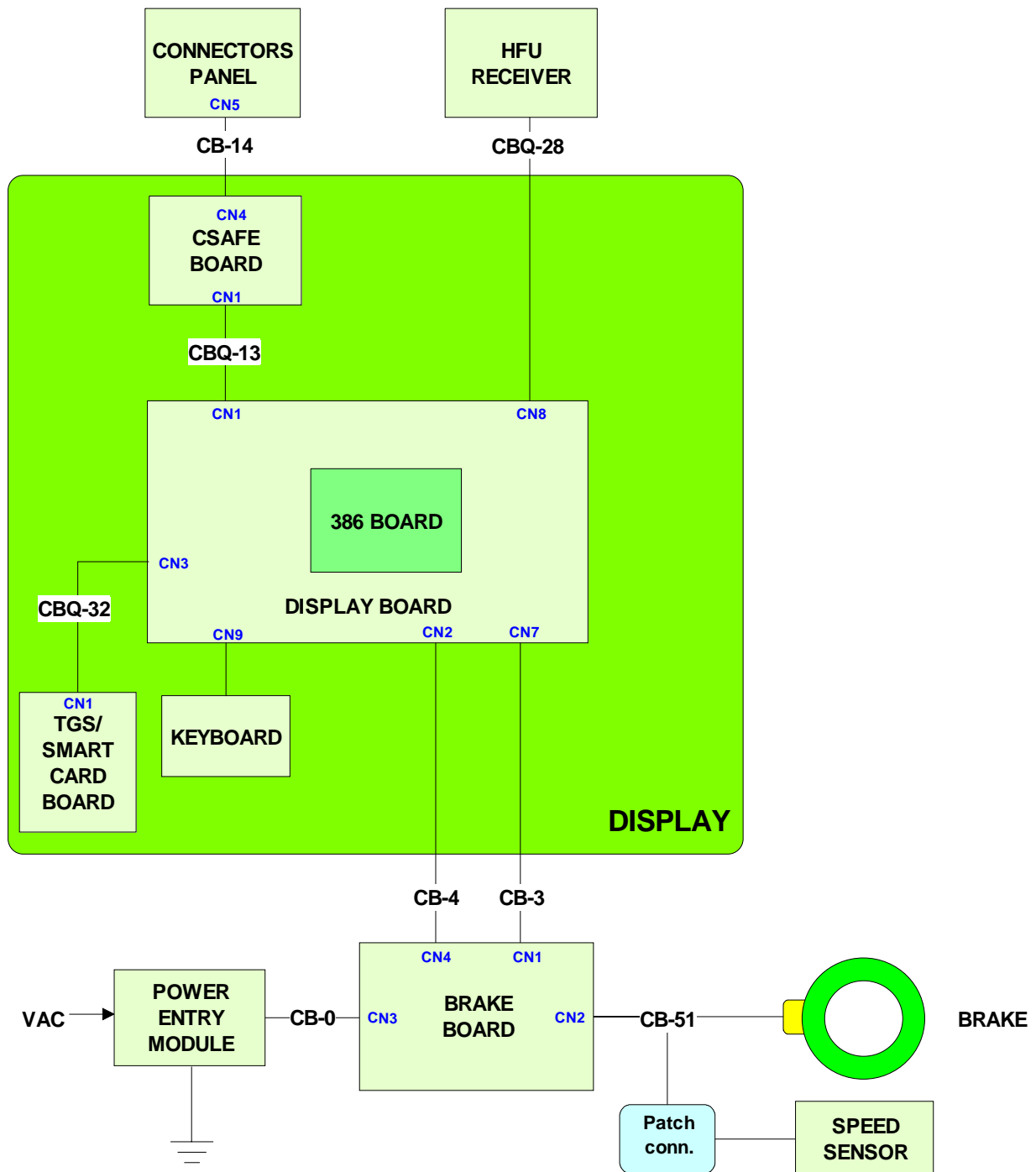

2.7.1.2. Cordless version

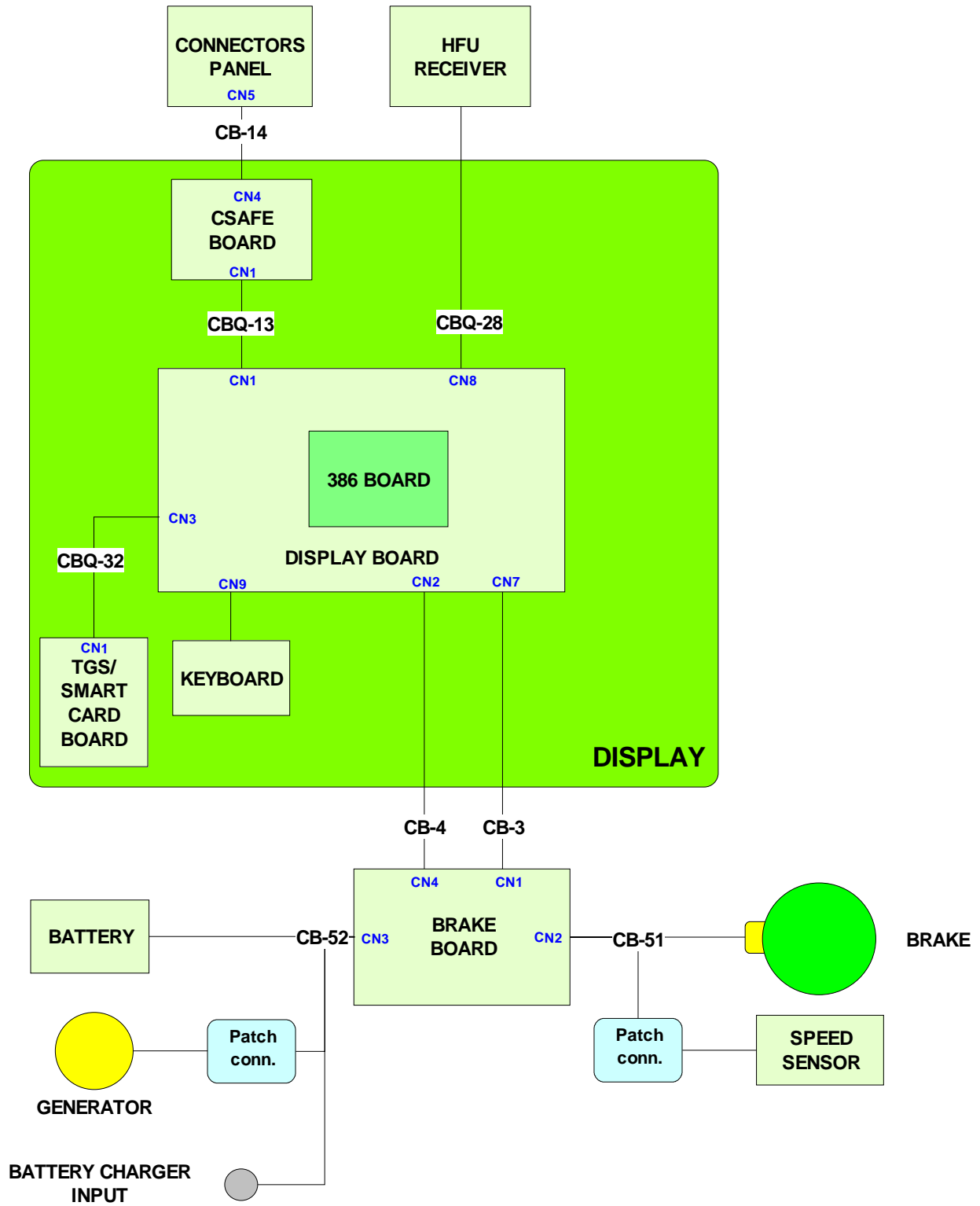

2.7.2. 700 MODEL

2.7.2.1. Powered version

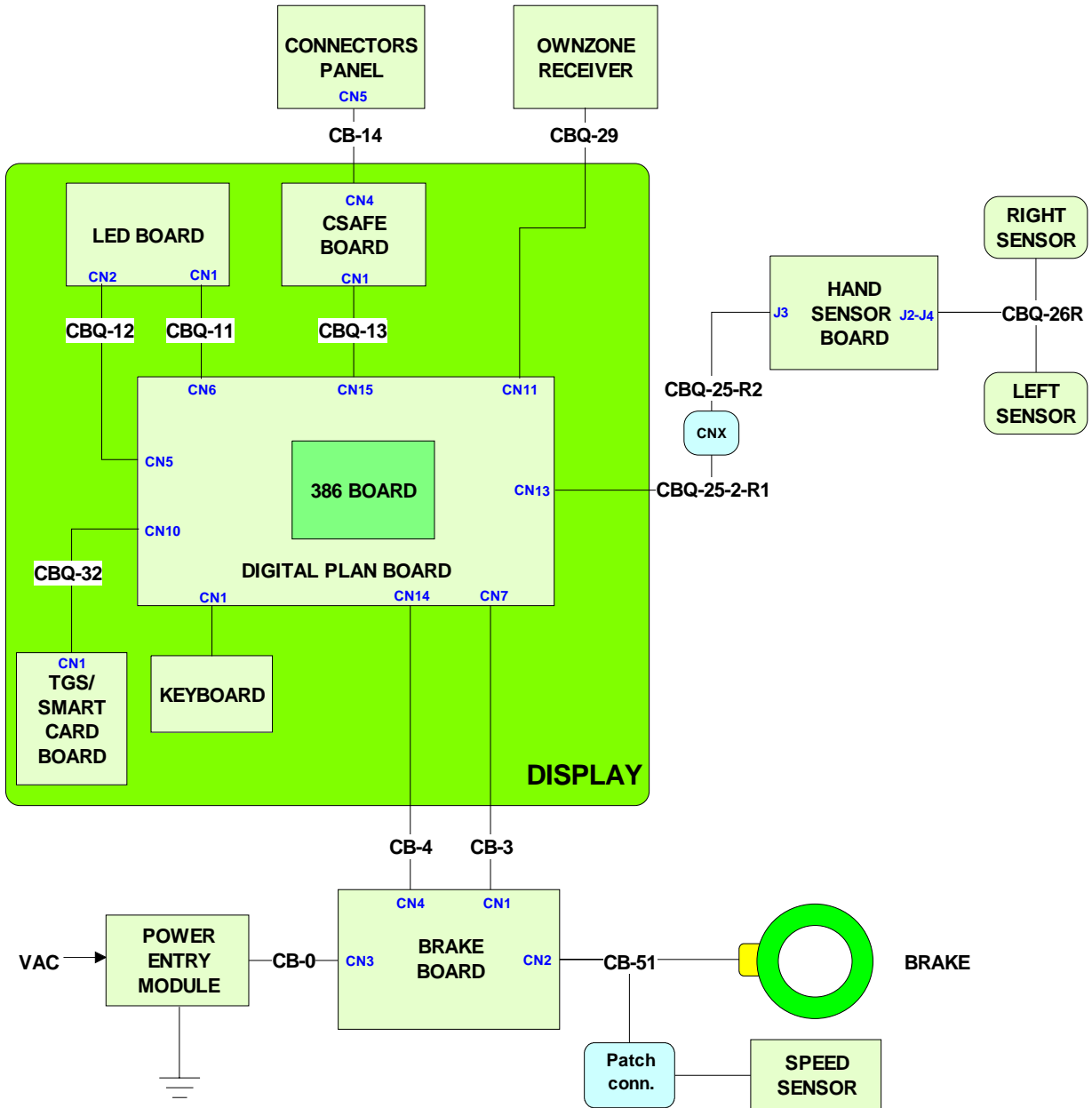

2.7.2.2. Cordless version

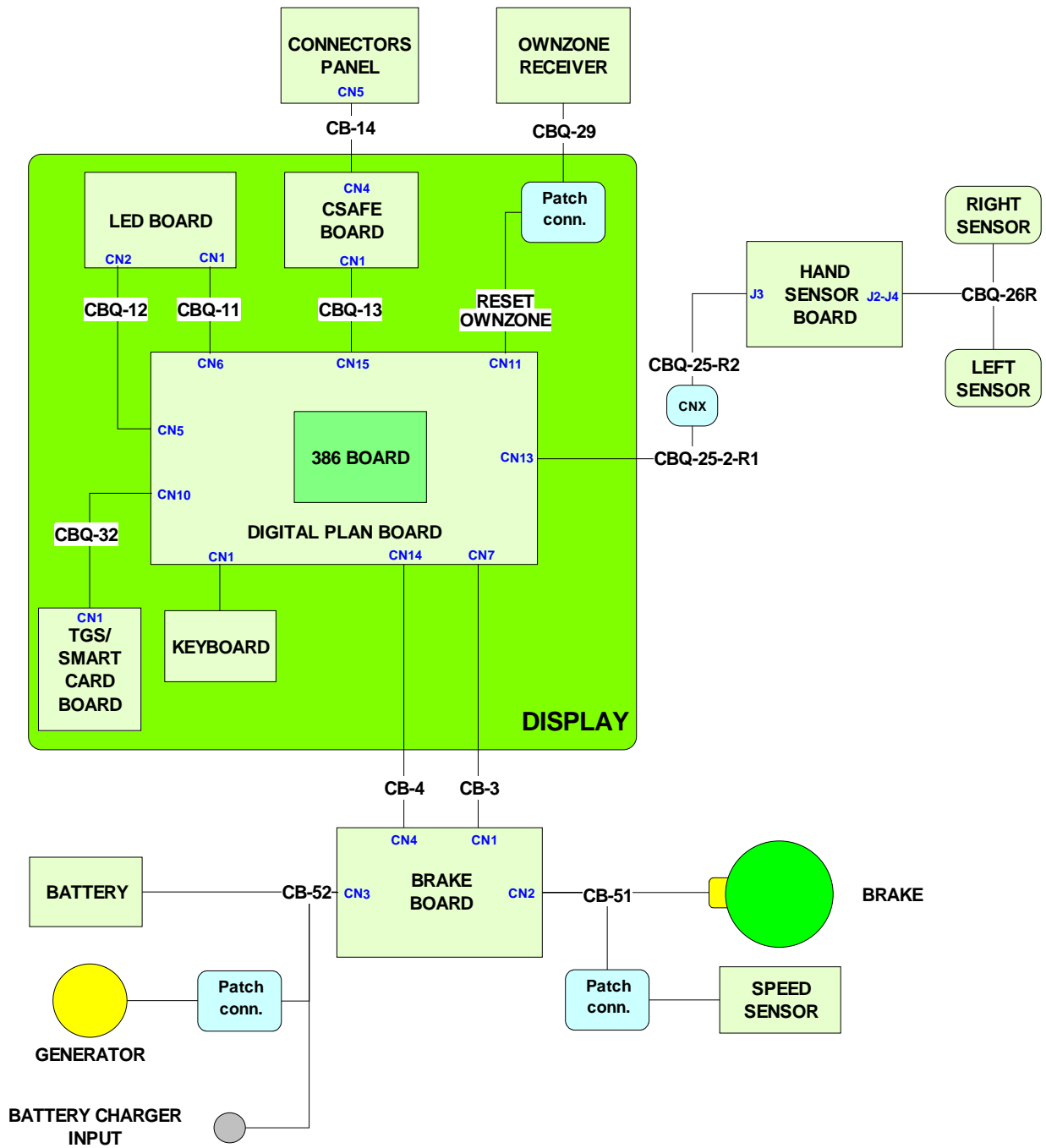

2.7.2.3. Wellness TV version

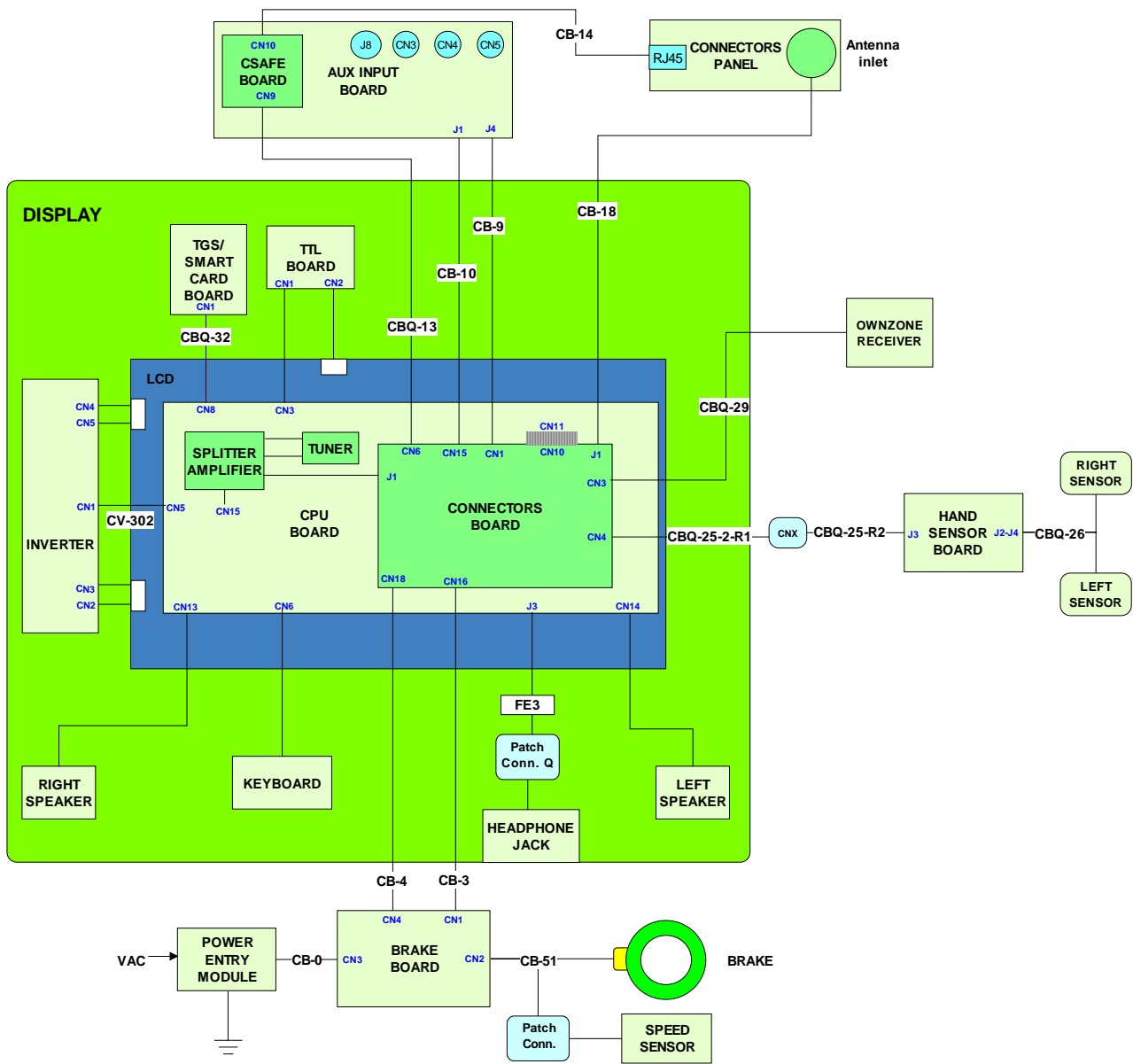

2.8. CABLES

CB-0: High voltage cable Power entry module – Brake board			
Power entry module	Signal	Color	Brake board CN3
N	Neutral	White	1
F	Line	Black	3
T	Earth	Green	5

CB-3: Cable connecting upper and lower assemblies Brake board – Digital plan board			
Brake board CN1	Signal	Color	Digital Plan Board CN7
2	Digital Gnd	White	2
3	Power Gnd	Orange	3
4	- sensing +5 Vdc digital	Red	4
6	+12 Vdc	Black	6
7	+5 Vdc	Green	7
8	+sensing +5 Vdc digital	Blue	8

CB-4: Serial communication cable between upper and lower assemblies Brake board – Digital plan board			
Brake board CN4	Signal	Color	Digital Plan Board CN14
1	NC	Green-White	1
2	NC	Green	2
3	Digital Gnd	Orange-White	3
4	Download	Blue	4
5	Reset	Blue-White	5
6	Digital Gnd	Orange	6
7	485 Tx/Rx +	Brown-White	7
8	485 Tx/Rx -	Brown	8

CB-9: Inlet DVD video cable Connectors board – AUX input board			
Connectors board CN1	Signal	Color	AUX input board J4
1	Color	Red	1
2	Left audio IN	White	2
3	Gnd	Shield	3
4	Right audio IN	Red	4
5	Gnd	Shield	5
6	Video IN	Yellow	6
7	Gnd	Shield	7
8	Commutation	White	8

CB-10: Inlet CD cable Connectors board – AUX input board			
Connectors board CN15	Signal	Color	AUX input board J1
1	Right audio IN	Red	1
2	Gnd	Shield	2
3	Left audio IN	White	3
4	Gnd	Shield	4

CB-14: Cable connecting CSafe – External connectors CSafe Board – Ext. connectors panel			
CSafe Board CN4	Signal	Color	Ext. connectors CN5
1	Digital #1	UTP CAT V	1
...
8	Digital #8	UTP CAT V	8

CB-51: Brake supply cable Brake board – Brake – Speed sensor				
Brake board CN2	Signal	Color	Brake	Speed sensor
1	Brake supply +	Brown	10	
2	Brake supply -	White	5	
3	RPM	Yellow		Faston connected to brown cable
4	RPM reference	Green		eyelet

CB-52: Alternator cable					
Brake board – Alternator – Battery – Inlet for battery charging					
Brake board CN3	Signal	Color	Alternator	Battery	Battery charging inlet
1	V+ voltage from alternator	Red	Faston		-
2	V- voltage from alternator	Black	Faston		-
3	V+ voltage from battery charger	Red	-		soldered to internal contact
4	V- voltage from battery charger	Black	-		soldered to external contact
5	Battery V+	Red	-	Faston	-
6	Battery V-	Black	-	Faston	-

CBQ-11: LED board power supply cable			
Digital Plan Board – LED Board			
Digital Plan Board CN6	Signal	Color	LED Board CN1
1	Gnd (digital)	White	1
2	Gnd (power)	Yellow	2
3	+5 Vdc power supply (digital)	Green	3
4	+5 Vdc power supply (power)	Brown	4

CBQ-12: LED board digital signal cable			
Digital Plan Board – LED Board			
Digital Plan Board CN5	Signal	Color	LED Board CN2
1	Digital #1	Flat cable	1
...
16	Digital #16	Flat cable	16

CBQ-13: CSafe board cable			
Digital Plan Board – CSafe Board			
Digital Plan Board CN15	Signal	Color	CSafe Board CN1
1	Digital #1	Flat cable	1
...
14	Digital #14	Flat cable	14

CBQ-25-2-R1: Hand sensor board cable Digital Plan Board – Patch connector			
Digital Plan Board CN13	Signal	Color	Patch connector CNx
1	+5 Vdc power supply	Red	2
4	Board Reset	Green	-
5	Pulse out	Blue	3
6	Reference	Black	1

WARNING: the cable sheath contains a circuit which, in response to a reset signal received from the Digital Plan board, is able to reset the hand sensor board by removing and subsequently reapplying the supply voltage

CBQ-25-R2: Hand sensor board extension cable Patch connector – Hand Sensor Board			
Patch connector CNx	Signal	Color	Hand sensor board J3
1	Reference	Flat cable	1
2	+5 Vdc power supply	Flat cable	2
3	Pulse out	Flat cable	3

CBQ-26R: Sensor cable Hand Sensor Board - Sensors				
Hand sensor board J2 - J4	Signal	Color	Sensors	
			RH	LH
1	Right sensor signal	Red	up	-
2	Sensor signal reference	White	down	-
4	Left sensor signal	Black	-	up
5	Sensor signal reference	Green	-	down

CBQ-28: HFU receiver cable Display board – HFU receiver			
Display board CN8	Signal	Color	HFU receiver
1	+5 Vdc power supply	Red	2
7	Pulse (beat to beat)	Blue	4
8	Gnd	Black	1

CBQ-29: OwnZone receiver cable Digital Plan Board – OwnZone Receiver			
Digital Plan Board CN11	Signal	Color	OwnZone Receiver
1	Supply voltage	Red	4
2	I2C clock	Green	1
3	I2C data	Yellow	2
4	External Reset	Orange	9
7	Pulse (beat to beat)	Blue	3
8	Gnd	Black	5

CBQ-32: TGS/smart card cable Digital Plan Board – TGS/Smart Card Board			
Digital Plan Board CN10	Signal	Color	TGS/Smart Card Board CN1
1	+12 Vdc power supply	Yellow	1
3	Rx	White	8
5	Tx	Green	7
9	Gnd	Brown	3

CV-302: LCD inverter power supply cable CPU board – LCD Inverter			
CPU board CN5	Signal	Color	LCD Inverter CN1
2	Gnd	Black	2
3	Supply voltage +3.3 Vdc	Black	3
4	Gnd	Black	4
5	Supply voltage +12 Vdc	Orangr	5

RESET OWNZONE: Own-zone reset cable Digital Plan board - CBQ-29 cable			
Digital plan board CN11	Signal	Color	CBQ-29 cable Patch conn.
1	Supply voltage +5 Vdc	Red	1
2	I2C clock	Yellow	2
3	I2C data	Green	3
4	External Reset	Brown	-
7	Pulse (beat to beat)	Blue	7
8	Gnd	Black	8

WARNING: the cable sheath contains a circuit which, in response to a reset signal received from the Digital Plan board, is able to reset the OwnZone receiver by removing and subsequently reapplying the supply voltage.

3. PRINCIPLES OF OPERATION

3.1. BLOCK DIAGRAM

The machine block diagram is illustrated in the figure below:

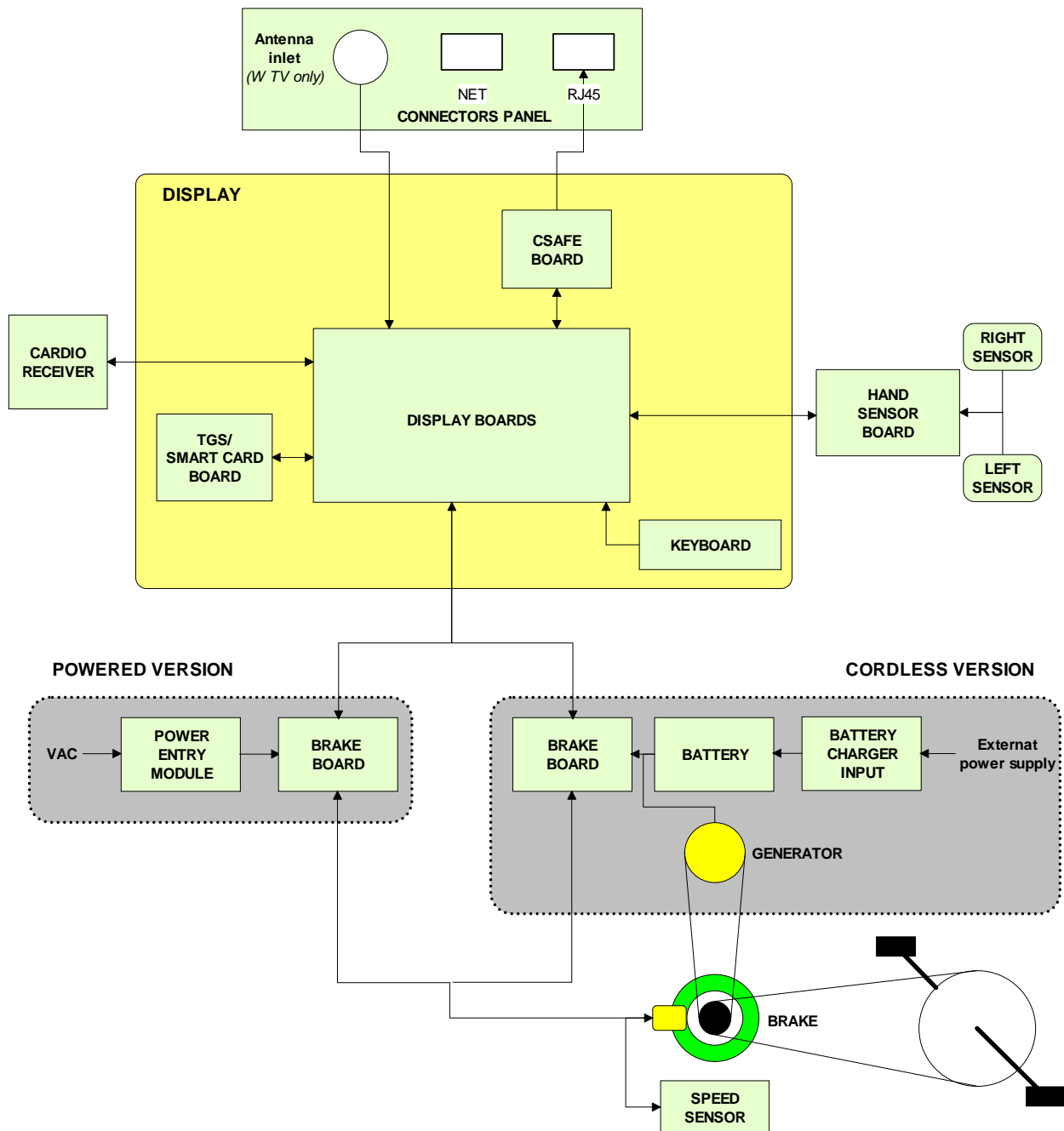

3.1.1. DISPLAY BOARDS

3.1.1.1. 500 and 500SP models

The display contains:

- **386 BOARD**

This is the circuit board which comprises the CPU, a 386 microprocessor, its logic circuits and a FLASH EPROM containing the operating program for the machine.

- **DISPLAY BOARD**

This is the heart of the display: this board acts as the interconnection hub for all the components of the display, and serves as the point of connection with the electrical box. In particular, its functions are:

- > receives commands of the machine program from the 386 Board;
- > sends to the 386 Board the signals received from:
 - Keyboard;
 - Cardio receiver;
 - TGS/Smart Card Board;
 - CSafe Board.
- > distributes to the display the voltages received from the Brake Board;
- > exchanges, over the RS-485 serial link to the Brake board, commands for controlling the Brake;
- > illuminates the LEDs and 7-segment displays used for the exercise feedback.

The board includes the following indicator LEDs:

LED name	Color	Description
DL1	green	if ON the +5 Vdc stabilized digital power supply is correctly generated.
DL2	green	if ON the +12 Vdc power supply provided by the Brake Board, correctly reaches the board.
DL3	orange	if ON the +5 Vdc power supply provided by the Brake Board, correctly reaches the board.

and 2 jumpers:

Jumper Name	Setting	Description
JP1	open	if short-circuited, resets the circuit board.
JP2	close	if short-circuited, keeps the memory powered when the machine is off.

3.1.1.2. 700 and 700SP models

The display contains:

- **386 BOARD**

This is the circuit board which comprises the CPU, a 386 microprocessor, its logic circuits and a FLASH EPROM containing the operating program for the machine.

- **DIGITAL PLAN BOARD**

This is the heart of the display: this board acts as the interconnection hub for all the components of the display, and serves as the point of connection with the electrical box. In particular, its functions are:

- > receives commands of the machine program from the 386 Board;
- > sends to the 386 Board the signals received from:
 - Keyboard;
 - Cardio receiver;
 - Hand Sensor Board;
 - TGS/Smart Card Board;
 - CSafe Board.
- > Distributes to the display the voltages received from the Brake Board;
- > Exchanges, over the RS-485 serial link to the Brake board, commands for controlling the Brake.
- > illuminates the LEDs and 7-segment displays used for the exercise feedback.

The board includes the following indicator LEDs:

LED name	Color	Description
DL1	not assembled	-
DL2	not assembled	-
DL3	green	if ON the +5 Vdc stabilized digital power supply is correctly generated.
DL4	orange	if ON the +5 Vdc power supply provided by the Brake Board, correctly reaches the board.
DL5	green	if ON the +12 Vdc power supply provided by the Brake Board, correctly reaches the board.

and 2 jumpers:

Jumper Name	Setting	Description
JP1	open	if short-circuited, resets the circuit board.
JP2	close	if short-circuited, keeps the memory powered when the machine is off.

- **LED BOARD**

Contains the circuits for the LEDs and the alphanumeric displays. The board includes the following indicator LEDs:

LED name	Color	Description
LED1	green	if ON the +5 Vdc digital power supply, stabilized by the Digital Plan board, correctly reaches the board.
LED 2	yellow	if ON the +5 Vdc power supply, provided by the Brake Board, correctly reaches the board.

3.1.1.3. 700E model (Wellness TV)

The display includes the boards:

- **CONNECTORS BOARD**

This board acts as the interconnection hub for all the components of the display, and serves as the point of connection with the electrical box. It includes connectors for the following:

- > Cardio receiver;
- > Hand sensor board;
- > CSafe board;
- > AUX input board;
- > Antenna signal;
- > Voltage received from the Brake board;
- > RS-485 serial link to the Brake.

It has a connector for linking to the CPU board, to transfer the collected signals.

The board includes the following indicator LED:

LED name	Color	Description
D10	red	if ON the +12 Vdc power supply provided by the Brake Board, correctly reaches the board.

and a faston:

Name	Description
J2	SHLD: denotes a ground node on the circuit board.

- **CPU BOARD**

This is the heart of the display: it is the circuit board which incorporates the CPU, a microprocessor, its control logic, the FLASH EPROM containing the operating program of the machine, and the tuner for the audio and video channels. Through the connector board, it receives signals from the various machine components.

This circuit board is directly connected to:

- > TGS/Smart Card board;



- > TTL board;
- > Keyboard;
- > Headphone Jack;
- > Splitter / amplifier;
- > Power supply inverter for LCD.

The main functions of the board are:

- > Distributes to the display the voltages received from the Brake Board;
- > Exchanges, over the RS-485 serial link to the Brake board, commands for controlling the Brake.
- > Tuning of audio and video channels;
- > Manages the display of images on the LCD.

The board includes the following 2 jumpers:

Jumper Name	Setting	Description
JP1	open	if short-circuited, enables a reset of the microprocessor.
CN2	open	if short-circuited, enables writing to the flash EPROM.

and a 3-pin connector (CN18) that can be used for testing the power supplies output by the board: 0 Vdc (ground), 5Vdc and 3.3 Vdc.

- **SPLITTER / AMPLIFIER**

This device amplifies the signal received from the antenna, separating the FM radio channel from the TV channel, which it sends to the tuner.

- **TTL BOARD**

It is an RGB buffer board with six bits per color, that interfaces the video signals sent from the CPU board to the LCD.

- **LCD INVERTER**

This device powers the LCD display segments. It receives DC power supplies (12 Vdc and 3.3 Vdc) from the CPU board, and generates the AC voltage (380 Vac) needed to supply the LCD.

- **AUX INPUT CONNECTORS**

This board provides 3 RC connectors and one mini DIN connector for interfacing external audio visual devices to the machine. An input on this board allows the external source to be displayed on the LCD base band.

- **HEADPHONE JACK**

Two jacks are provided on the machine for connecting headphones. The two jacks are connected in parallel to a stereo output of the CPU board. In addition to the audio signals, the connector also includes a sense signal for routing the output to either the headphones or external speakers, if the latter are installed. The sense contact is NC and opens when the headphone jack is plugged in.

3.1.2. CSafe BOARD

This board makes available a communication port, on 2 externally accessible connectors, which can be used for connecting compatible CSafe devices such as the CardioTheater readers. These connectors are situated one on the back of the display and the other on the connectors panel underneath the front platform.

These connectors can also be interfaced, by means of a special cable, to an external PC for programming the FLASH EEPROM.

3.1.3. TGS/SMART CARD BOARD

This board enables the machine to read the TGS key or Smart Card inserted by the user for doing workouts programmed with the Wellness System. The machine can be interfaced with either a TGS key or Smart Card reader, hence its name TGS/Smart Card Board.

3.1.4. HAND SENSOR BOARD

This is the board which manages the hand sensors, interfacing them to the Digital Plan Board. It processes the analog signal received from the sensors and outputs one pulse for each heart beat that is detected. The signal level is normally 5 Vdc; it goes to 0 Vdc when the user's hands are placed on the contacts, and a 5 Vdc pulse (having a width of approximately 30 msec) is output at each detected heart beat.

3.1.5. CARDIO RECEIVER

This board manages the signal received from the telemetric transmitter used by the person exercising. There are 2 types of receiver:

- **HFU Model (on 500 models):** this is the standard product. It receives the power supply signal from the display Board and outputs a negative logic pulse for every heart beat that is detected: the signal level is normally 5 Vdc, with a pulse at 0 Vdc (having a width of approximately 30 msec) at each heart beat.
- **OwnZone Model (on 700 and 700E models):** this is a special receiver model produced by Polar, equipped with a microprocessor and capable of independently detecting the heart rate. It receives the power supply signal from the Digital Plan board, to which it is connected by:
 - > a pulse signal: a pulse for every heart beat that is detected;
 - > a reset signal: an external reset signal provided by the digital plan board every times an exercise is started;
 - > a serial signal on a I2C protocol.

The receivers reception area is approximately a circle with a 1 m radius. If there is electromagnetic noise (produced by high voltage lines, radio transmitters, monitors, motors etc.) within this area, the receiver becomes saturated and no longer receives any signal.



On the 700SP models a reset cable between the OwnZone receiver and the Digital Plan has been added in order to avoid that the receiver overwrites some configuration data when the machine turns on.

3.1.6. CONNECTORS PANEL

This is located on the side of the front platform, and provides:

- an RJ45 socket for connecting CSafe compatible devices.
- (on 700E model only) a connector for the antenna cable.

3.1.7. BRAKE BOARD

There are 2 versions of the brake board, one which is used on the mains powered version and the other on the self-powered version. In either case, the brake board consists of:

- Power supply section which generates the low voltages used by the machine: +5 Vdc and +12 Vdc. Depending on the machine version, these voltages will be generated either from the 110 VAC or 220 VAC mains supply, or from the alternator-battery.
- Section for RS-485 serial communications with the Digital Plan Board for:
 - commands determining the resistance that is required of the brake;
 - brake error messages;
 - the commands for modifying the circuit board configuration parameters;
 - the commands for viewing the errors logged by the circuit board.
- Section which generates the current for the brake winding: varying the current produces a proportional variation in the resistance of the brake. The excitation current supplied to the brake is a function of the effort level selected on the display and the RPM value measured by the speed sensor (angular velocity of the brake disk) and is determined by the values stored in the braking table.

The board includes the following indicator LEDs:

LED name	Color	Description
LED1	green	if ON the board is supplying the brake winding. if BLINKING the brake board is in an error condition.
LED2	yellow	if ON there is the +5 Vdc supply from the circuit board.

and 2 jumpers:

Jumper Name	Setting	Description
JP1	open	
JP2	open	

3.1.8. BRAKE

This is an eddy current brake, consisting of a flywheel mass and a flat copper disk that rotates in the air gap of a winding. Variations in the winding current produce a change in the resulting field, which consequently varies the eddy currents induced within the copper disk and hence its resistance to movement.

The winding has a resistance of approximately 4.8 Ohm.

3.1.9. SPEED SENSOR

This consists of a magnetic induction sensor which detects the heads of the brake disk fixing screws.

3.1.10. POWER ENTRY MODULE



Only for 500, 700 and 700E versions.

This is a block consisting of:

- power inlet socket;
- power outlet socket;
- fuse-holder for protecting line voltage and neutral with two 3.15A fast-blow fuses.

Situated on the side of the rear platform. The Power entry module has a maximum current rating of 10A. This determines the maximum number of machines that can be connected together. Therefore, do not connect more than 30 Recline Excite machines with a 220 VAC mains supply, or 15 machines with a 110 VAC mains supply.



WARNING: If other types of machines are connected together, the maximum number is determined by their current draw.

3.1.11. ALTERNATOR



Only for 500SP and 700SP versions.

The alternator consists of a stator winding whose rotor is put into rotation by the movement of the pedals, generating the voltage necessary for the machine's operation.

Depending on the rate of pedaling and the resulting speed of rotation, it generates an alternating voltage which ranges from approximately 15-17 VAC at about 30-35 RPM to over 40 VAC for higher pedaling speeds.

3.1.12. BATTERY



Only for 500SP and 700SP versions.

This is a 12 V – 4.5 AH battery which, in the self-powered version, supplies the machine whenever the alternator is unable to produce a sufficient voltage for powering the machine, and for at least 30 seconds after the user has stopped pedaling to allow data to be saved in memory.

The battery can be recharged in 2 ways:

- during the exercise, through the brake board;
- in the standby condition, from an external power supply included with the machine, which is able to fully recharge the battery in 8 hours.



Do not use the machine during recharging with the external power supply.

3.1.13. EXTERNAL POWER SUPPLY INPUT



Only for 500SP and 700SP versions.

This is a socket for plugging in the external power supply that comes with the machine, which can be used to recharge the battery. It is situated on the side of the rear platform.

3.2. BRAKE CONTROL

3.2.1. MECHANICS

The movement of the pedals puts the brake into rotation by means of a belt. The speed sensor, connected to the machine frame, detects the heads of the brake disk fixing bolts and provides a signal representing the RPM.

3.2.2. CONTROL

The control block diagram is as follows:

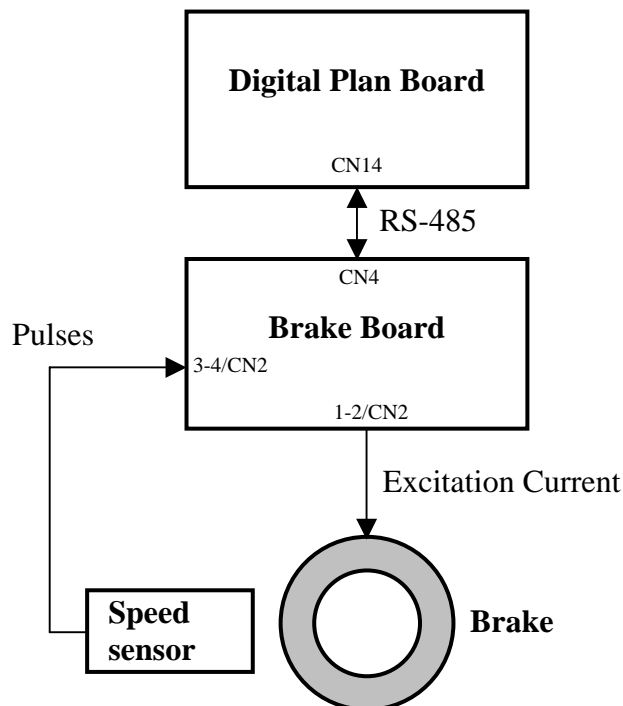

The resistance which the user perceives on the pedals is a combination of 2 factors:

- **mechanical:** mechanical efficiency of the linkages and more generally the mechanical friction of the system as a whole. The mechanical friction has been measured in the laboratory and is determined by a specific SW function of the upper kit.
- **electrical:** resistance produced by the brake;

To obtain a given exercise effort level, the digital plan board sends the required value of “electrical” resistance to the brake board via the RS-485 serial link. Based on the commands received and the feedback signal from the speed sensor, the brake board will then apply the appropriate excitation current to the brake winding and generate an electromagnetic field.



The value of the current applied is based on the value of the brake table memorized into the brake board.

The electromagnetic field produced by the winding and the rotation of the disk will induce eddy currents in the disk itself, giving rise to a force which tends to brake its motion. This produces the exercise resistance.

A higher brake excitation signal will produce a correspondingly higher exercise resistance. In addition, for a given value of magnetic field, a higher speed of disk rotation will produce a correspondingly higher exercise resistance.



Due to the eddy currents, energy is dissipated on the brake disk in the form of heat.



The brake board effects an open loop control of the brake, with no provision for regulating the value of resistance produced. The precision of the braking system has a tolerance of ±10%.

During the movement, the speed sensor detects the heads of the brake disk fixing bolts, and produces a speed feedback signal that is sent to the brake board.



If the brake board does not receive a speed signal which indicates that an exercise session is in progress, the machine will not produce any resistance.

During the movement, the brake board checks for possible malfunctions. The errors which can occur are:

Error Code	Description
1	OVERHEATING: this condition occurs when the temperature measured by the sensor on the circuit board exceeds 90°C.
2	OVERCURRENT: this condition occurs when the current going to the solenoid measured by the board exceed the max value.
4	UNDERVOLTAGE: this condition occurs when the +12 Vdc voltage drops below 9.7 Vdc (only on the 500, 700 and 700E model).
8	OVERVOLTAGE: this condition occurs when the +12 Vdc voltage goes above 13.7 Vdc (only on the 500, 700 and 700E model).
16	WATCHDOG: this condition occurs when the brake board SW crashes.
32	EPROM: SW error on the brake board.
128	MACHINE NOT CALIBRATED: this error condition occurs when the calibration parameter stored in the brake board is incorrect.

In the case of error 128, the machine will continue to function completely, but the braking resistance produced will not correspond to the value entered on the display. In all other cases, the brake board interrupts the supply of current to the brake and sends an error message to the digital plan board which displays the “THE EQUIPMENT IS BLOCKED” message.

3.2.3. THE SIGNALS INVOLVED

The machine uses the following control signals:

- **RS-485 Signal**

This is a digital signal exchanged between the brake board and the digital plan board. There is no provision for monitoring its state.

- **Excitation current**

This is the current generated by the brake board (pins 1-2 of connector CN2) which supplies the brake winding. The current supplied is a function of the selected effort level and the speed of the exercise.

- **Pulses**

This is the signal produced by the speed sensor, and has the waveform shown below:

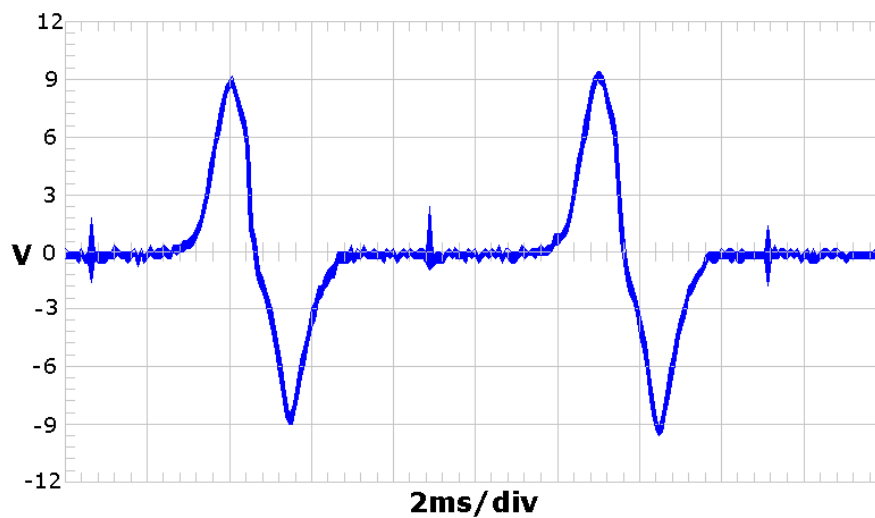

Figure 3.2-1

The signal enters the brake board (pins 3-4 on connector CN2), where it is used to determine the speed value that is sent to the digital plan board via the RS-485 serial link.



This signal can also be measured qualitatively using a multimeter. With the machine stopped the voltage measured across the sensor terminals should be 0 Vdc, and while pedaling it should go to a few hundred mV: the higher the speed, the higher the measured value.

4. ACCESSORIES

4.1. CARDIO THEATER CONNECTION

The machine can be connected to the CardioTheater by means of the RJ45 connector on the CSafe board. The CardioTheater unit must be provided with a power cable having the following pin-out:

RJ45 Connector	Signal
5	+5 Vdc
7	Ground

In the RJ45 connector, which is illustrated below, pin 1 is the farthest right when the locking tab is facing upward.

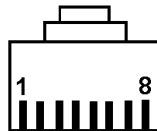

The remaining pins are not connected.

4.2. PC LINK FOR PROGRAMMING

The machine can be connected to a PC for programming by means of the RJ45 connector on the CSafe board.

The cable to use (code **0WC00434AA**) must be wired as follows:

PC Cable CSafe Board - PC			
CSafe Board RJ45	Signal	Color	PC 9 pin D- connector
3	Rx	White-Green	3
4	Tx	Blue	2
7	Ground	White-brown	5
5	R = 10 KOhm	-	-
6		-	-

In the RJ45 connector, which is illustrated below, pin 1 is the farthest right when the locking tab is facing upward.

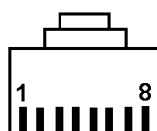

4.3. PROGRAMMING PLUG FOR CSAFEE BOARD

When programming the machine using the **0WC00434AA** connecting cable described above, it is necessary to fit plug (code **0WC00638AA**) into the free RJ-45 port on one side of the front platform, to avoid any type of interference during the operation.

The wiring diagram of the RJ-45 plug is as follows:

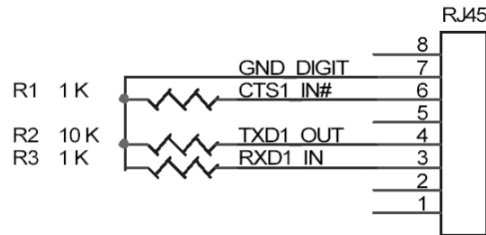

4.4. CABLE FOR EXCHANGING TV CHANNEL TUNING DATA BETWEEN TWO MACHINES

The connection between two machines for transferring the TV channel tuning data is effected via a special cable, connected to the RJ45 connectors of the CSafe boards.

The cable to use (code **0WC00644AA**) must be wired as follows:

Cable			
CSafe board RJ45	Signal	Color	CSafe board RJ45
3	Tx	White	4
4	Rx	Brown	3
7	Digital Ground	Green	7
8	Shield Ground	Yellow	8

On the RJ45 connector, which is illustrated below, pin 1 is the farthest right when the locking tab is facing upward.

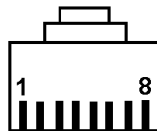

4.5. MONITOR PLUG FOR CSAFE PORT

When the plug code **0WC00639AA** is fitted into any one of the CSafe ports on the machine, the corresponding LED should illuminate to indicate the presence of the 5 Vdc supply on the port. During the CSafe port test function, the plug connects the transmit channel directly to the receive channel, thereby producing a positive test outcome if the port is functioning correctly.

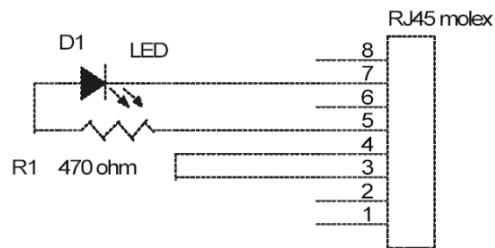

4.6. WELLNESS TV UPGRADE KIT

There are upgrade kits available for converting Excite machines from the version with traditional LED display to the version with Wellness TV display. The kit also includes all the cables and connectors required for the input of the antenna signal. The table below gives the codes of the kits for each machine.

WELLNESS TV UPGRADE KIT	CODICE
RECLINE 700	A0000120AA
RECLINE 700 TGS KEY	A0000121AA
RECLINE 700 SMART CARD	A0000122AA

Where the character ‘#’ must be replaced with the multistandard code matching the TV standard of the country where the machine has to be installed:

Multistandard code	TG code	TV Standard	Countries			
E	1	PAL B/G	Albania Australia Austria Bahrain Belgium Cameroon Croatia Cyprus Czech Rep Denmark Finland Germany Ghana Greece Hungary India Israel Italy Jordan Kenya Luxembourg Malaysia Malta Netherlands New Zealand Nigeria Norway Pakistan Poland Portugal Romania Singapore Slovakia Slovenia Spain Sri Lanka Sweden Switzerland Thailand Turkey United Arab E Zambia Zimbabwe			
			2	PAL I	Botswana Hong Kong Ireland South Africa Seychelles UK	
			5	SECAM E/L	France	
			6	SECAM D/K	Bulgaria Estonia Ex URSS Latvia Lithuania Poland Russia Ukraine	
			8	PAL D/K	Czech Rep China Poland	
			9	SECAM B/G	Saudi Arabia Iran Iraq Morocco Tunisia Syria	
			A	SECAM K1	French Guyana Guadeloupe Madagascar Martinique New Caledonia Senegal Togo Zaire	
			U	3	PAL N	Argentina Paraguay Uruguay
				4	NTSC	Bahamas Bermuda Canada Chile Costa Rica Guatemala Japan Korea Peru Philippines Taiwan Trinidad USA Venezuela
				7	NTSC M44	Mexico
B	PAL M	Brazil				

Table 4-1

4.6.1. INSTALLATION PROCEDURE



WARNING: Do not perform this installation if the SW version of the brake interface board is 9.56.x or lower.



NOTE: It is always advisable, in any case, to upgrade the brake interface board to the latest SW version.

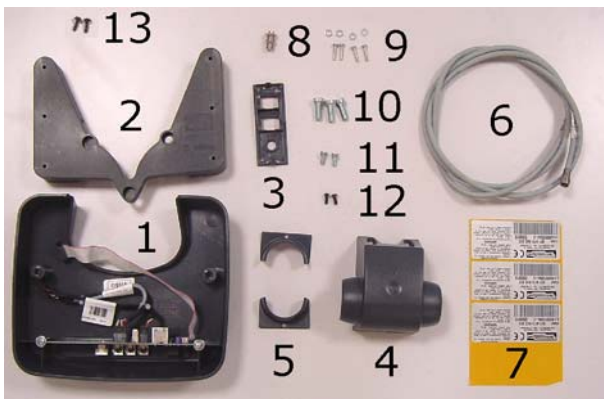

Figure 4.6-1



Figure 4.6-2

The upgrade kit consists of:

- (1) Back of the display;
- (2) Display support flange (cod. **0C001412AA**);
- (3) Connector plate (cod. **0G000353AB**);
- (4) Upper handlebar cover (cod. **0C000529AA**);
- (5) Lower handlebar cover (cod. **0C000530AA**);
- (6) CB-18 cable (cod. **0WC000443AB**);
- (7) Code sticker (cod. **0E109**);
- (8) Union connector (cod. **0K00303AA**);
- (9) Self-tapping screws (cod. **0Z00090**) and washers (cod. **0Z343**);
- (10) Low cheese-head screw (cod. **0ZV00011**);
- (11) Cheese-head screws (cod. **0Z165**);
- (12) Black screws (cod. **0ZV00140AA**);
- (13) Self-tapping screws (cod. **0Z775**);
- (14) 12-inch LCD display assembly.



Figure 4.6-3

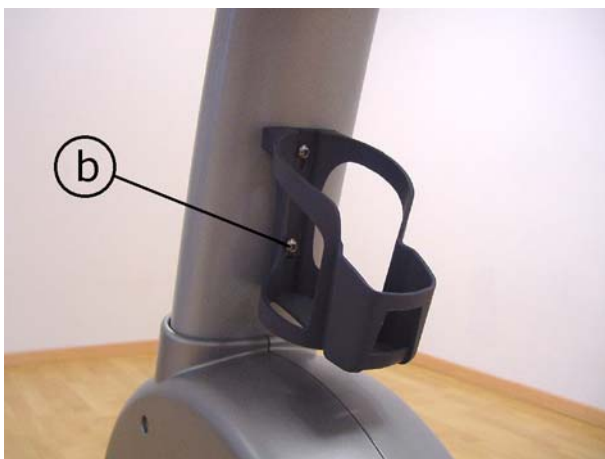

Figure 4.6-4



Figure 4.6-5

1. Turn off the machine and unplug the mains lead from the wall outlet.
2. Back off the 6 screws **a** using a Phillips screwdriver.
3. Open the display, disconnect its cables and remove it from the machine.

4. Back off the screw **b**, using a 4-mm hex T-wrench.
5. Rotate the bottle holder upward.

6. Back off the 7 screws **c** using a 4-mm hex T-wrench.
7. Position the right pedal at the top and remove the right guard.



This operation may be awkward. If in difficulty, perform the standard procedure which involves disassembling the 2 pedal cranks and then removing the right guard.

Continued on following page →

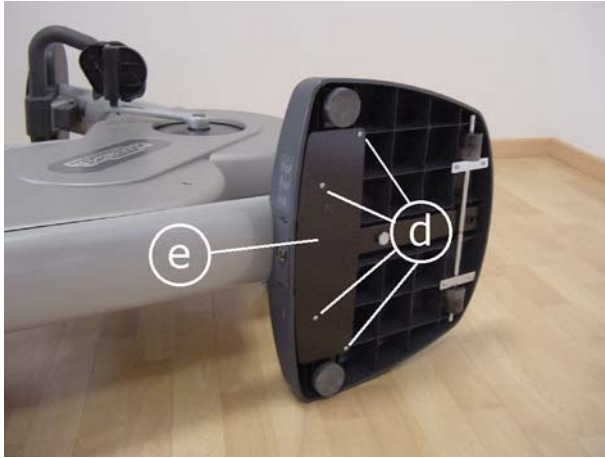

Figure 4.6-6

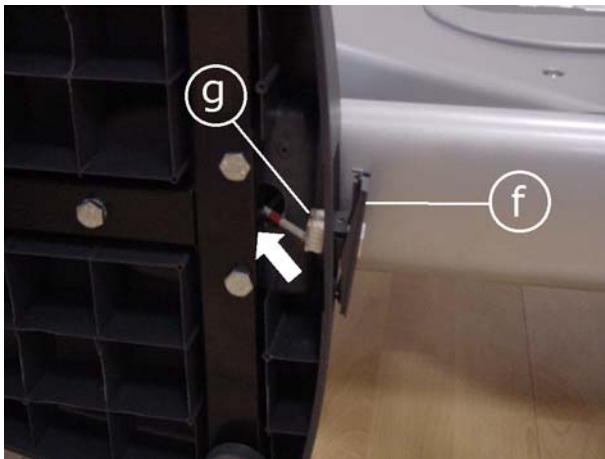

Figure 4.6-7

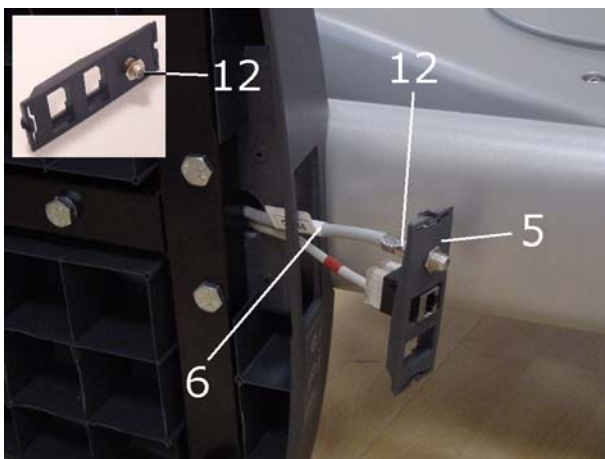



Figure 4.6-8

8. Turn the machine over on one side.
9. Back off the 4 screws **d** using a Phillips screwdriver.
10. Remove the cover **e**.

11. Push the connector plate **f** outward.
12. Unplug the CSafe connector **g**.
13. Remove the connector plate **f**.
14. Insert cable **6** CB-18 into the hole indicated by the arrow, and run it alongside the CSafe cable until it comes out on the display side.

 **Because the display column is interrupted, as can be seen in Fig. 7, it will be difficult for the cable to reach the display. Therefore, route it along at least the first section of column.**

15. Fix the union connector **12** to the connector plate **5**, securing it with its own lock-nut.
16. Plug the lower end of cable **6** TRM-18 into connector **12**.
17. Reconnect the CSafe connector that was unplugged previously.
18. Insert the connector plate **5** into the platform.
19. Reassemble the guards disassembled previously.
20. Turn the machine back upright.

Continued on following page →

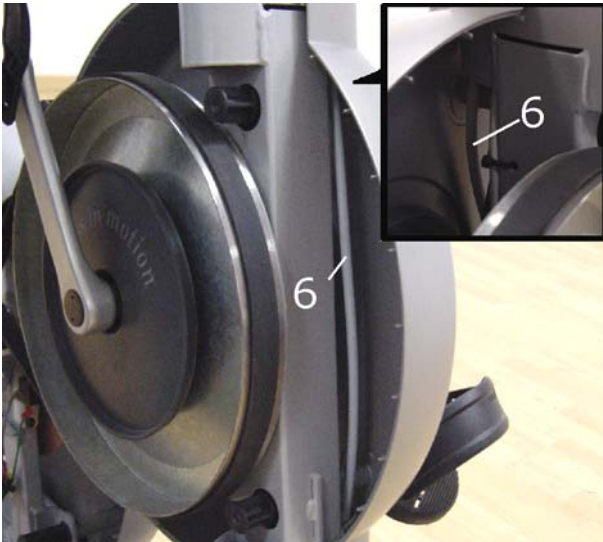

Figure 4.6-9

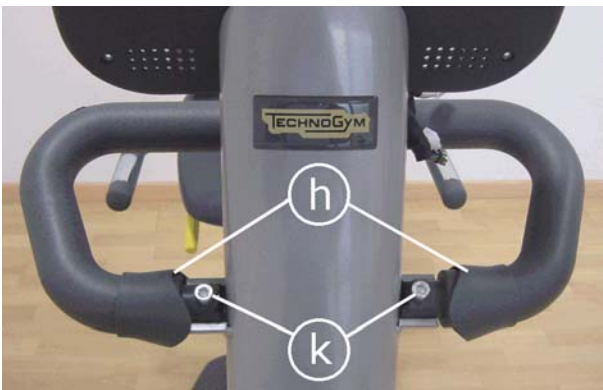

Figure 4.6-10

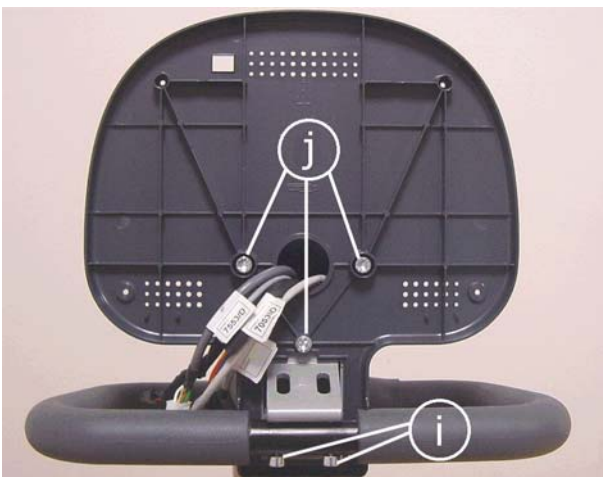

Figure 4.6-11

21. Insert cable **6** CB-18, routing it toward the display alongside the group of cables which connect the upper and lower parts of the machine. More specifically:

- insert it into the left part of the 2 column sections
- when inserting it into the second column section, route it along the back as indicated in the box.

22. Use a cable tie to attach cable **6** CB-18 to the existing group of cables.

23. Reassemble the right guard that was disassembled previously.

24. Move away the 2 rubber covers **h** to access the screws **k**.

25. Back off the 2 screws **k** using a 6-mm hex T-wrench.

26. Back off the 3 screws **f** using a 6-mm hex T-wrench.

27. Remove the handlebar.

28. Back off the 3 screws **g** using a 6-mm hex T-wrench.

29. Remove the display support.

30. Back off the 2 screws **i** using a 6-mm hex T-wrench.

31. Remove the handlebar.

32. Back off the 3 screws **j** using a 6-mm hex T-wrench.

33. Remove the display support.

34. Reassemble the handlebar that was disassembled previously.

Continued on following page →

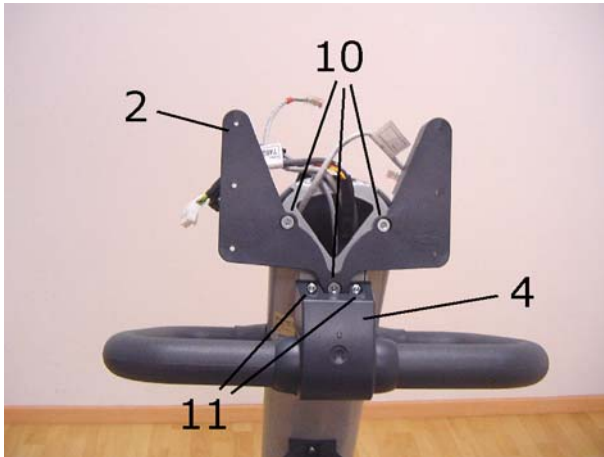

Figure 4.6-12



Figure 4.6-13



Figure 4.6-14

35. Install the display support flange **2**, locking down the 3 screws **10** using a 5-mm hex T-wrench.

36. Assemble the upper handlebar cover **4** using the 2 screws **11** and a 4-mm hex T-wrench.

37. On each side, assemble the lower handlebar cover **5** with screw **12**, using a 2.5-mm hex T-wrench.

38. Insert the back of the display **1** as shown in the figure, and slide it along the display column until it rests against the handlebar.

Continued on following page →



Figure 4.6-15



Figure 4.6-16



Figure 4.6-17

39. Affix the sticker **7** with the machine serial number onto the LCD display, in the position shown in the figure.

40. Assemble the LCD display on its support, using the 4 screws and 4 washers **9**.

41. Place the back of the display **1** near the LCD display.

42. Plug all the cables back into their connectors.

43. Close the back of the display **1** using the 2 screws **13** and a Phillips screwdriver.

44. Turn on the machine and check that it is working properly.

45. Perform the configuration and tuning procedure for the Wellness TV.

5. INSTALLATION INSTRUCTIONS

5.1. SPECIFICATIONS AND REQUIREMENTS

For correct machine installation, make sure that:

1. The machine is installed on a level surface that is free of vibrations and has sufficient carrying capacity for the combined weight of the machine and user.
2. The place of installation is free of dust and sand.
3. The place of installation meets the operating temperature and humidity conditions specified in paragraph 2.4. "Ambient specifications".
4. The machine is not positioned close to sources of heat, sources of electromagnetic noise (television sets, electrical motors, antennas, high voltage lines, household appliances, etc...) or medical equipment.
5. To eliminate any interference with the cardio receiver, no transmitters should be placed less than 1 meter from the display.

Only for the 500, 700 and 700E models:

6. The mains voltage must match the value specified on the machine rating plate.
7. The electrical system must be correctly earthed.
8. The wall outlet used should be reserved for the machine and have a rating of at least 50 VA.
9. The maximum number of machines connected in cascade should be that indicated in paragraph 3.1.10. "Power entry module".
10. Position the mains lead of the machine where it will not be underfoot.

5.2. SPECIFICATIONS AND REQUIREMENTS TO INSTALL A WELLNESS TV MACHINE

1. Ensure that the specifications and requirements for installation have been met (see paragraph 5.1. "Specifications and requirements").
2. To obtain a good video signal, the S/N ratio at the antenna signal input of a Wellness TV machine should be between 70 and 80 dB.

WARNING: If the machine is not connected to a terrestrial antenna--or if it is but the antenna signal line is interrupted by devices such as TV distribution units, modulators, etc.--the machine will not be able to receive a usable antenna signal for radio channel tuning.

5.3. INSTALLATION

To correctly install the machine, proceed as follows:

1. Ensure that the specifications and requirements for installation have been met (see paragraph 5.1. “Specifications and requirements”).
2. Position the machine as specified above, on a level surface that is free of vibrations and has sufficient carrying capacity for the combined weight of the machine and user.
3. The machine is shipped fully assembled and packed in a carton fixed to a wooden pallet.

Only for the 500, 700 and 700E models:

4. Connect the mains lead to the power inlet socket on the machine.
5. Place the on/off switch in the “0” position.
6. Plug the mains lead into the wall outlet.

Only for the 700E model:

7. Connect the antenna cable to the wall outlet.

5.4. FIRST POWER-ON

After completing the installation procedure, the machine is ready for use.

On the 500, 700 and 700E models, simply turn the on/off switch from position 0 to position 1, while on the 500SP and 700SP models it is necessary to get on the machine and start pedaling.

On power-up the machine performs a self test of the upper and lower assemblies. At the end of this the machine goes into standby, awaiting a keyboard command.

To check the correct operation of the machine:

- get on the machine;
- begin exercising;
- check that the displayed speed varies accordingly;
- check that the exercise resistance varies when the “+” and “-” keys are pressed, and that the effort level LEDs turn on and off accordingly;
- put on the heart rate meter and check that the machine correctly reads the heart rate value;
- only on 700, 700SP and 700E grasp the sensors and check that the machine correctly reads the heart rate value.

6. TROUBLESHOOTING

The troubleshooting procedures are shown in the form of flow charts. In order to facilitate consultation, the following standard box shapes are used.



This type of box is the **START** point of the troubleshooting procedure. It typically contains a description of the problem or malfunction.

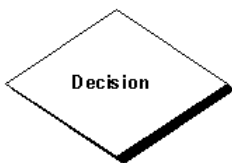

This type of box represents a decision point in the troubleshooting procedure. It typically contains a description of the **CHECK** to be made, with an outcome that can be either a positive (**YES**) or negative (**NO**) response.

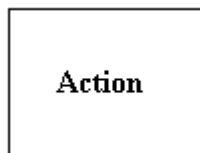

This type of box is a step in the troubleshooting procedure where an **ACTION** must be carried out. It typically contains a description of the **ACTION** necessary to resolve the problem. Therefore, after executing the specified **ACTION**:

1. Check whether the problem has been resolved;
2. If the problem persists, it is recommended to resume the troubleshooting procedure from the point before the action was carried out.



A circled number (such as that shown on the left) next to a box of the troubleshooting procedure indicates that detailed instructions for performing that particular check or action are provided below the flowchart.



A circled letter (such as that shown on the left) is used to highlight a point in the procedure. Typically, this indicator is used in page changes.

6.1. SERVICE TROUBLESHOOTING MENU FOR 700 MODELS

This section can be used to test the operation of certain machine components (brake board, LED display, keyboard, serial ports). It is invoked when the machine is in standby by simultaneously pressing the keys **369**. The following prompt appears on the display:

ENTER PASSWORD:

To access the procedure, type in the password **2501** which protects against unauthorized access and press **ENTER** to confirm. At this point there are two options available:

- 1 = Tech Config
- 2 = Troubleshooting

Press the number key **2** to access the troubleshooting menu, which is structured as shown in the figure below.

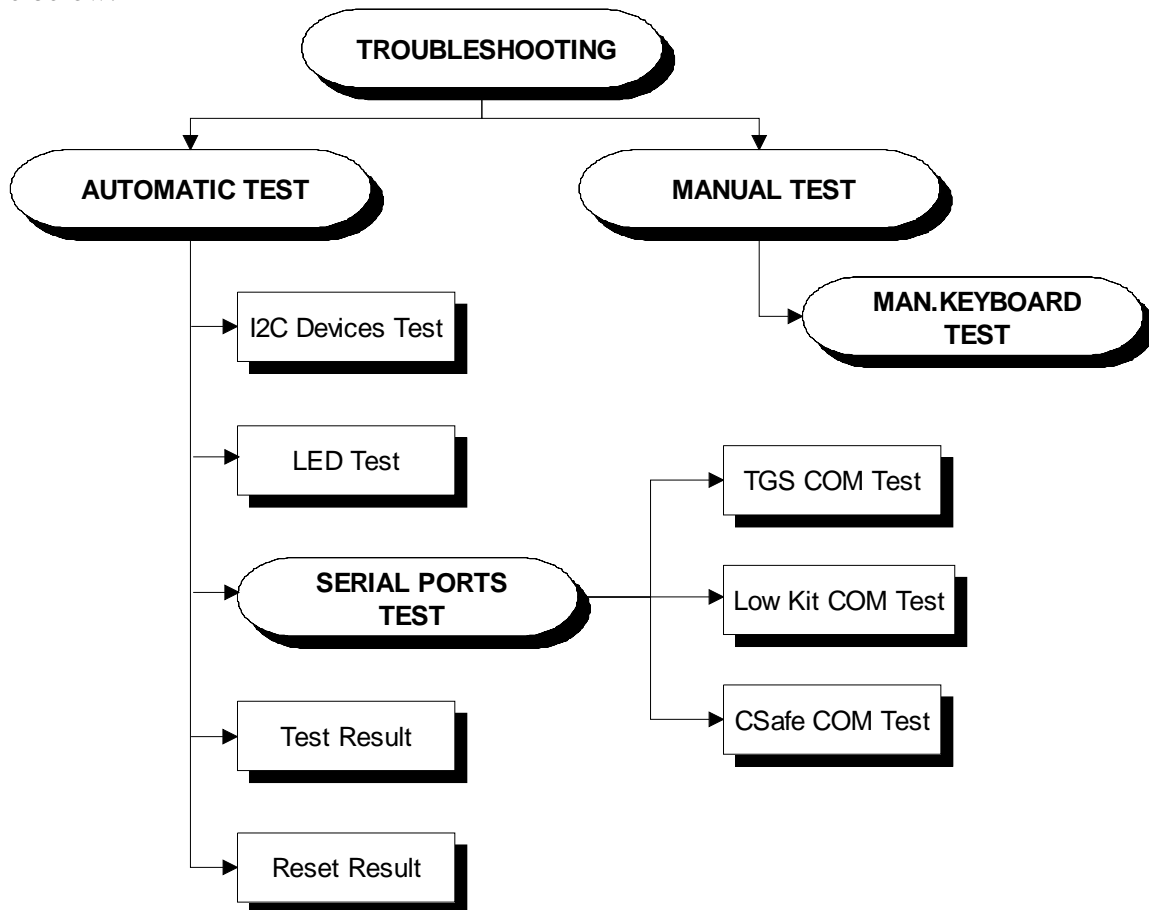

To scroll through the list of available functions, press the + or – effort level keys to display the next or the preceding item; confirm the choice by pressing **ENTER**. To cancel the operation, press the **CLEAR** key for a few seconds.

The tests are divided into two groups: Automatic and Manual, and the prompt for a choice appears immediately on accessing the troubleshooting menu.

6.1.1. AUTOMATIC TEST

The tests grouped under this section conduct checks on the machine's operation in a fully automatic manner. After selecting the desired test using the + and – effort level keys, press **ENTER** to initiate the test and then await the result. Press **ENTER** again to continue, and use the **CLEAR** key to return to the higher menu level, holding it down for a few seconds. The various manual tests are described below.

6.1.1.1. I2C Devices Test

The I2C Devices test checks the communication following the 32K and 256K memories and the operation of the OwnZone receiver only for what concerns the data reception function, but not the detection of the heart rate signal. The test can have two outcomes:

- **“Test Successful, press Enter to continue”** : Signifies that the transmission and reception of data packets between the I2C devices and the digital plan board was completed successfully.
- **“OwnZone error, press Enter to continue”** : Signifies that the transmission and/or reception of data packets between the OwnZone and the digital plan board was not completed successfully.
- **“EEPROM Error, press Enter to continue”**: Signifies that the CPU board has communication problems with the memories.

6.1.1.2. LED Test (not on 700E models)

The LED test checks the functioning of the display by lighting all the LEDs in the matrix. It also tests the buzzer by changing the frequency to produce a variation in the tone of the sound.

There is no message displayed concerning the outcome of this test, which the user must therefore check visually.

6.1.1.3. Serial Ports Test

The serial ports test checks the communications on the port for connecting to:

- CSafe COM test;
- Low Kit COM test;
- TGS COM test.

Using the + and – effort level keys, select the desired test item and confirm by pressing **ENTER**. The test can have two outcomes:

- **“Test Successful, press Enter to continue”**: This means that the test was completed successfully, i.e. that the communications on the selected serial port are correct.
- **“COMx Error, press Enter to continue”**: This means that the outcome of the test was negative: the message will specify COM1 in the case of the CSafe COM test, COM2 in the case of communications with the low kit, or COM3 in the case of the TGS COM test.

6.1.1.4. Test Result

This function is used for viewing the outcomes of the various tests:

- EEPROM32K;
- EEPROM256K;

- RTC (Real Time Clock);
- OWNZONE;
- COM1;
- COM2;
- COM3;
- KEYBOARD.

Pressing ENTER displays a messages with either OK or KO alongside each of the above items, depending on whether the outcome of the corresponding test was favorable or not.

Note that if this function is invoked without having previously run any tests, it will show a negative outcome for all the items. This is because it merely displays the results, but does not actually carry out the tests.

6.1.1.5. Reset Result

This function clears the output of the Test Results viewing function, resetting the outcomes of all the tests to KO.

6.1.2. MANUAL TEST

This section groups together tests for manually checking the operation of certain peripheral devices. After selecting the desired test using the + and – effort level keys, press **ENTER** to initiate the test and then await the result. To exit test mode, hold down the **CLEAR** key for a few seconds.

6.1.2.1. Man. Keyboard Test

The manual keyboard test checks the functioning of all the keys on the keyboard. After accessing the test by pressing **ENTER**, the message “**Press all buttons (beep=OK)**” appears on the display. Pressing each key will produce an audible signal, if a key does not produce the “beep” it means it is not working properly.

On Wellness TV machines, pressing the keys does not produce an audible signal, but if the key is working correctly it lights up green.

6.2. SERVICE TROUBLESHOOTING MENU FOR 500 MODELS

This section can be used to test the operation of certain machine components (brake board, LED display, keyboard, serial ports). It is invoked when the machine is in standby by simultaneously pressing the keys **ENTER**, **↑**, **CLEAR**. The following prompt appears on the LED display:

ENTER PASSWORD:

To access the procedure, insert the password **2501** which protects against unauthorized access and press **ENTER** to confirm. To enter the password without the numeric keypad, enter one digit at a time using the **↑** and **↓** keys to change the value and the **+/- GOAL** keys to scroll to the next character. At this point there are two options available:

↑ = Tech Config
↓ = Troubleshooting

Press the number key **↓** to access the troubleshooting menu, which is structured as shown in the figure below.

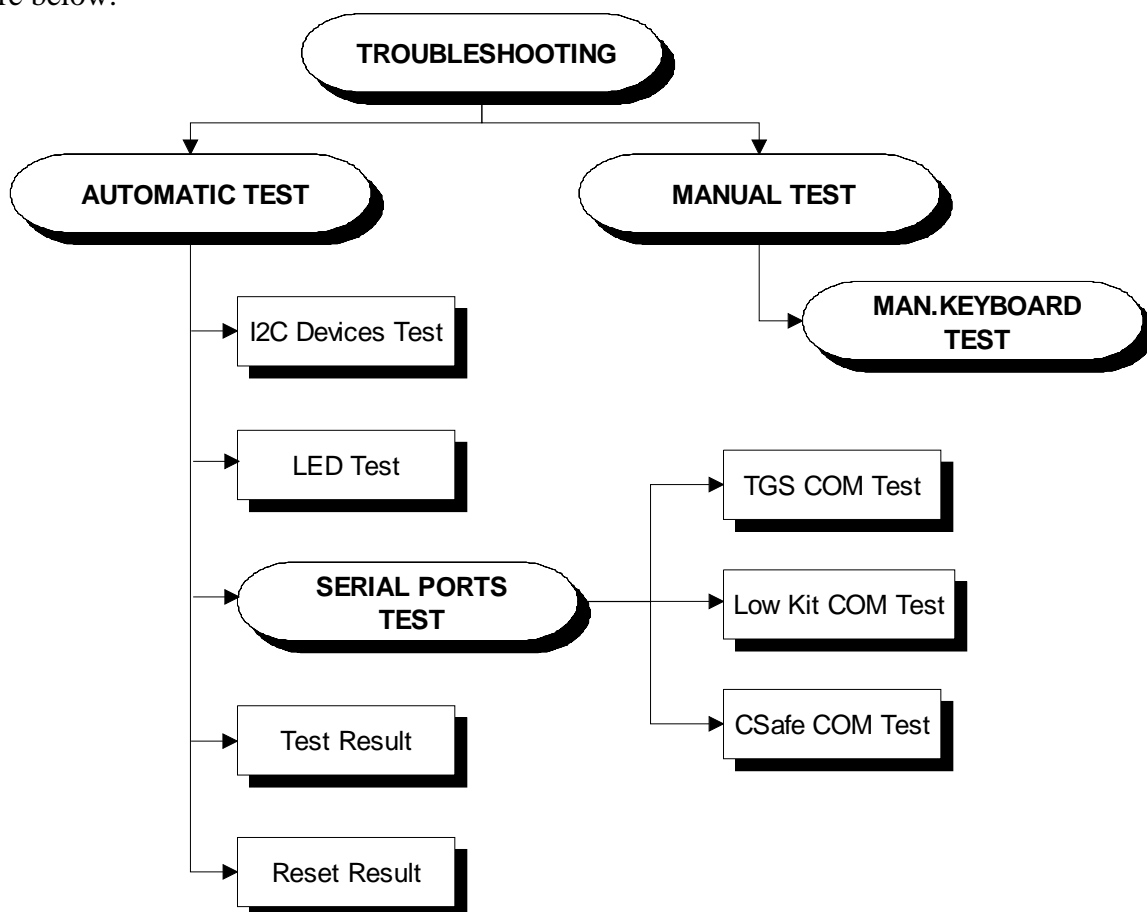

To scroll through the list of available functions, press the **+** or **-** effort level keys to display the next or the preceding item; confirm the choice by pressing **ENTER**. To cancel the operation, press the **CLEAR** key for a few seconds.

The tests are divided into two groups: Automatic and Manual, and the prompt for a choice appears immediately on accessing the troubleshooting menu.

6.2.1. AUTOMATIC TEST

The tests grouped under this section conduct checks on the machine's operation in a fully automatic manner. After selecting the desired test using the + and – effort level keys, press **ENTER** to initiate the test and then await the result. Press **ENTER** again to continue, and use the **CLEAR** key to return to the higher menu level, holding it down for a few seconds. The various manual tests are described below.

6.2.1.1. I2C Devices Test

The I2C Devices test checks the communication following the 32K and 256K memories. The test can have two outcomes:

- **“Test Successful, press Enter to continue”** : Signifies that the transmission and reception of data packets towards the display board was completed successfully.
- **“EEPROM Error, press Enter to continue”**: Signifies that the display board has communication problems with the memories.

6.2.1.2. LED Test

The LED test checks the functioning of the display by lighting all the LEDs in the matrix. It also tests the buzzer by changing the frequency to produce a variation in the tone of the sound.

There is no message displayed concerning the outcome of this test, which the user must therefore check visually.

6.2.1.3. Serial Ports Test

The serial ports test checks the communications on the port for connecting to:

- CSafe COM test;
- Low Kit COM test;
- TGS COM test.

Using the + and – effort level keys, select the desired test item and confirm by pressing **ENTER**. The test can have two outcomes:

- **“Test Successful, press Enter to continue”**: This means that the test was completed successfully, i.e. that the communications on the selected serial port are correct.
- **“COMx Error, press Enter to continue”**: This means that the outcome of the test was negative: the message will specify COM1 in the case of the CSafe COM test, COM2 in the case of communications with the low kit, or COM3 in the case of the TGS COM test.

6.2.1.4. Test Result

This function is used for viewing the outcomes of the various tests:

- EEPROM32K;
- EEPROM256K;
- RTC (Real Time Clock);
- OWNZONE;
- COM1;
- COM2;

- COM3;
- KEYBOARD.

Pressing ENTER displays a message with either OK or KO alongside each of the above items, depending on whether the outcome of the corresponding test was positive or negative.

Note that if this function is invoked without having previously performed any tests, it will show a negative outcome for all the items. This is because it merely displays the results, but does not actually carry out the tests.

6.2.1.5. Reset Result

This function clears the output of the Test Results viewing function, resetting the outcomes of all the tests to KO.

6.2.2. MANUAL TEST

This section groups together tests for manually checking the operation of certain peripheral devices. After selecting the desired test using the + and – effort level keys, press **ENTER** to initiate the test and then await the result. To exit test mode, hold down the **CLEAR** key for a few seconds.

6.2.2.1. Man. Keyboard Test

The manual keyboard test checks the functioning of all the keys on the keyboard. After accessing the test by pressing **ENTER**, the message “**Press all buttons (beep=OK)**” appears on the display. Pressing each key will produce an audible signal, if a key does not produce the “beep” it means it is not working properly.

6.3. THE DISPLAY FAILS TO ILLUMINATE

This error occurs when the power supply voltage does not reach the upper assembly. This may also be due to a short circuit on the brake winding, which interrupts the output voltage of the brake board, causing the upper assembly to switch off.

6.3.1. 500 AND 700 MODELS

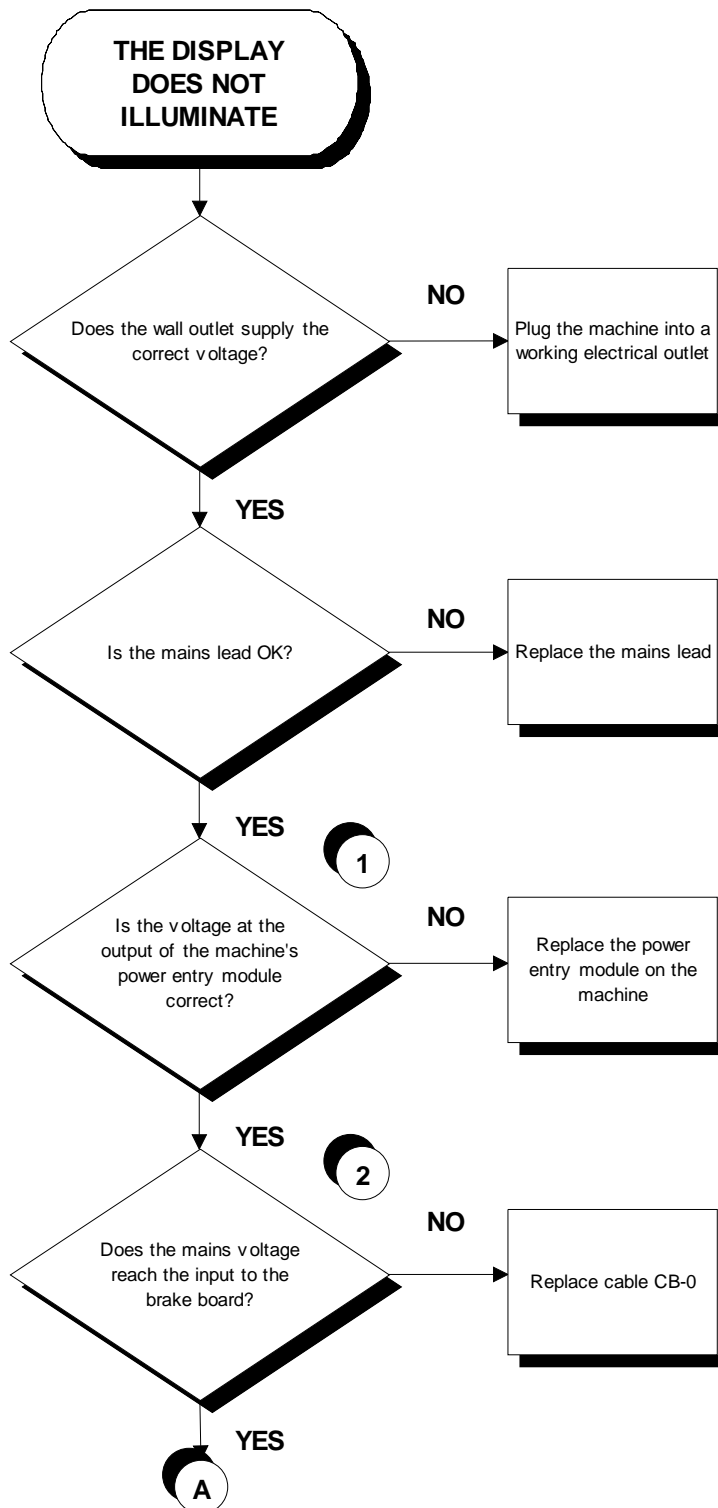

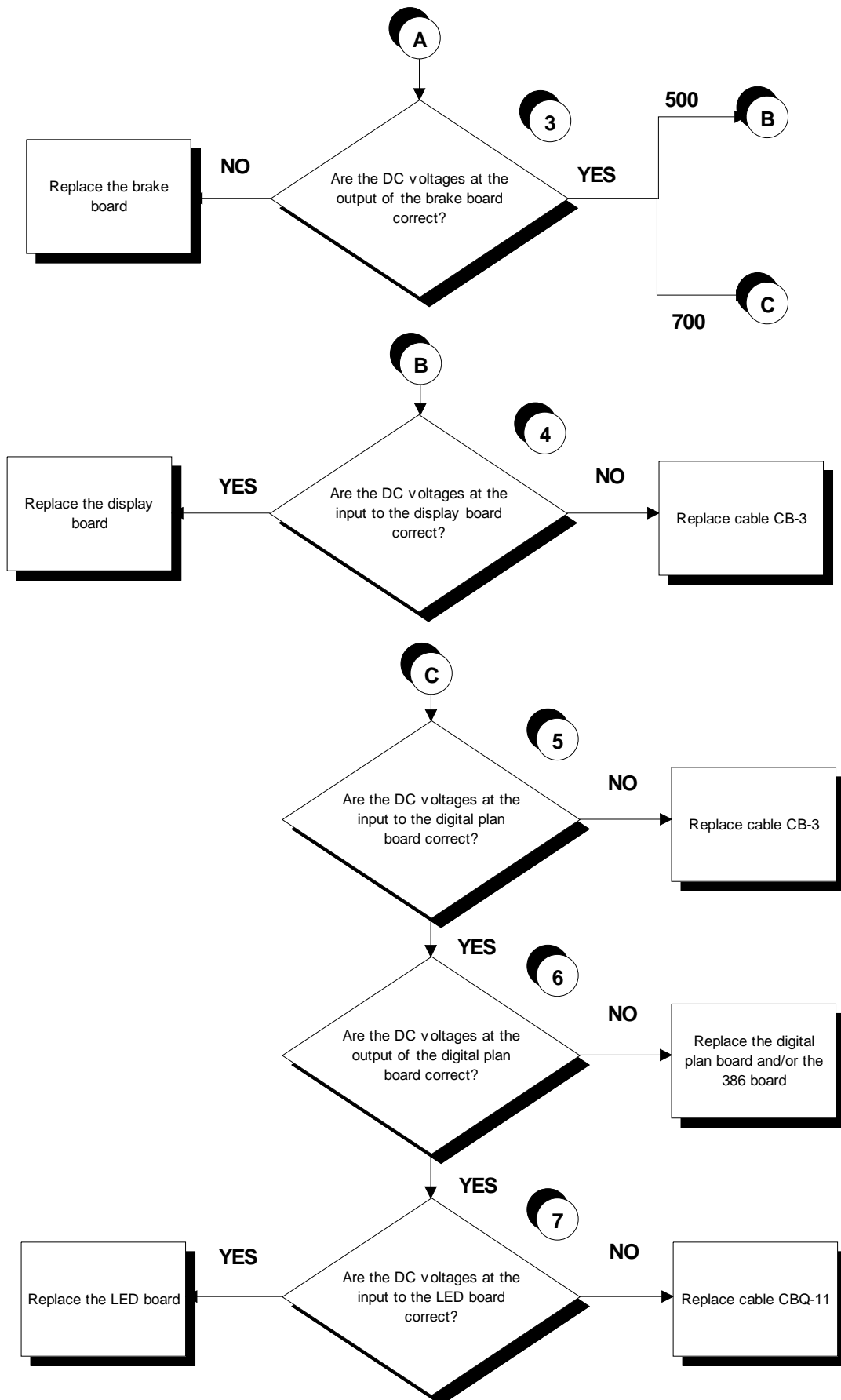

Follow the procedure step by step to correctly diagnose the problem. Take particular care with the checks highlighted by circled numbers, which are described in detail below:



To speed up the troubleshooting procedure, check the state of the power indicator LEDs on the various circuit boards.

- (1) Slightly lift up the Faston connectors on the machine power inlet socket. Place the tester probes across the live and neutral pins on the same connector. The measured value should be approximately 220 VAC or 110 VAC depending on the mains voltage.
- (2) As for step (1) but across pins 3 and 1 of connector CN3 on the brake board.
- (3) Using a tester, check that all the output voltages on connector CN1 of the brake board are correct, referring to paragraph 2.8. "Cables".
- (4) As for step (3) but on connector CN7 of the display board.
- (5) As for step (3) but on connector CN7 of the digital plan board.
- (6) As for step (3) but on connector CN6 of the digital plan board.
- (7) As for step (3) but on connector CN1 of the LED board.

6.3.2. 500SP AND 700SP MODELS

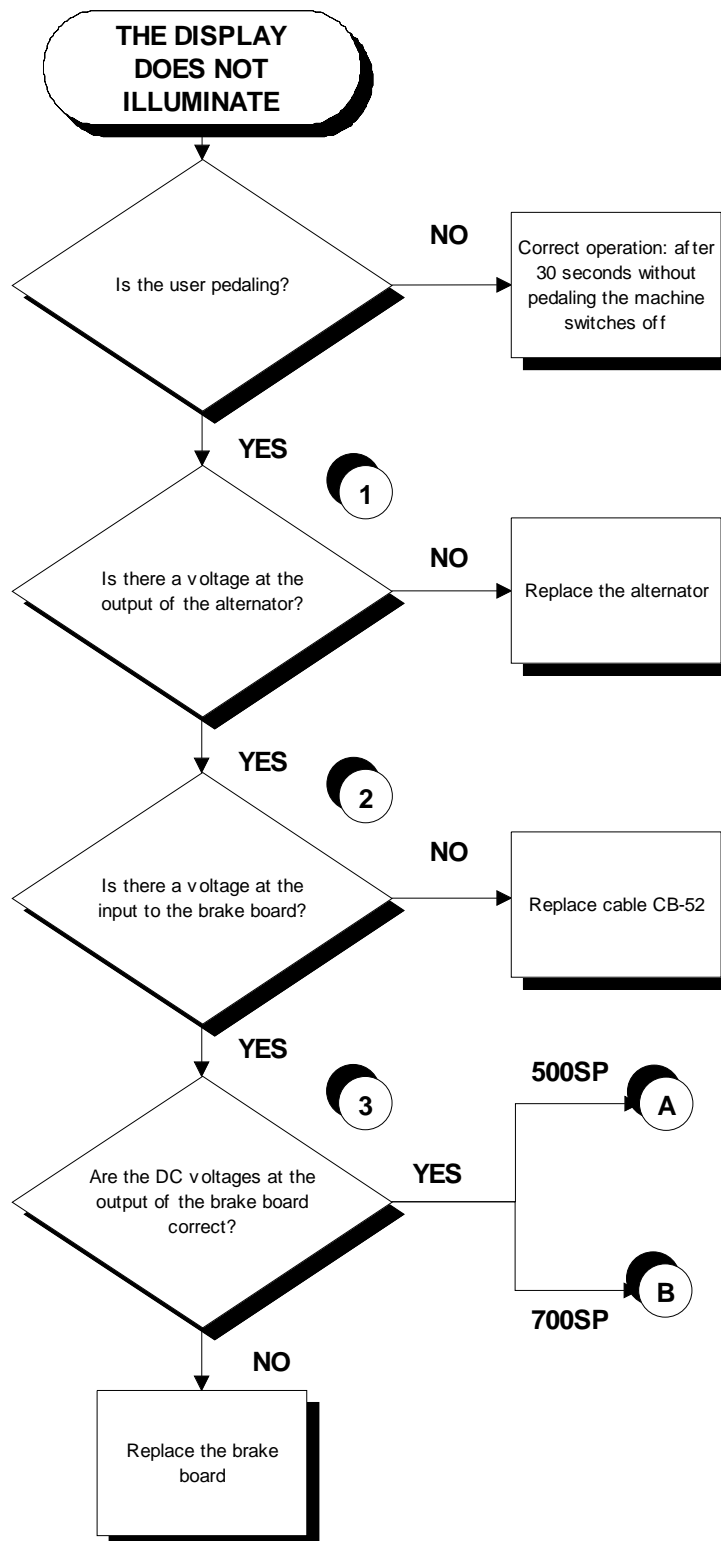

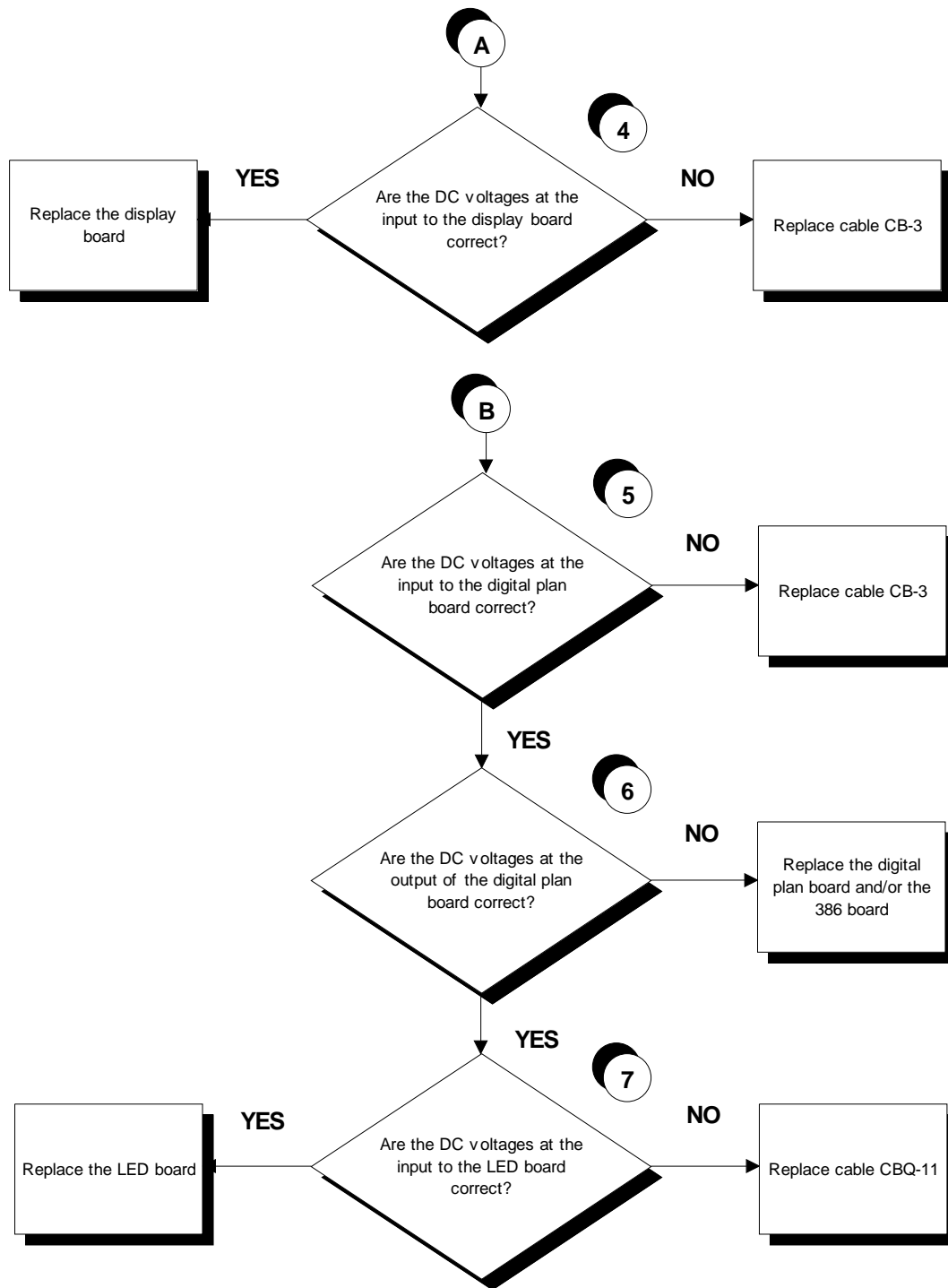

Follow the procedure step by step to correctly diagnose the problem. Take particular care with the checks highlighted by circled numbers, which are described in detail below:



To speed up the troubleshooting procedure, check the state of the power indicator LEDs on the various circuit boards.

- (1) Place the tester probes across the ends of the cable from the alternator. The measured voltage should be approximately 15-17 VDC at a speed of about 30 RPM.
- (2) As for step (1) but across pins 1 and 2 of connector CN3 on the brake board.
- (3) Using a tester, check that all the output voltages on connector CN1 of the brake board are correct, referring to paragraph 2.8. "Cables".
- (4) As for step (3) but on connector CN7 of the display board.
- (5) As for step (3) but on connector CN7 of the digital plan board.
- (6) As for step (3) but on connector CN6 of the digital plan board.
- (7) As for step (3) but on connector CN1 of the LED board.

6.3.3. 700E WELLNESS TV MODELS

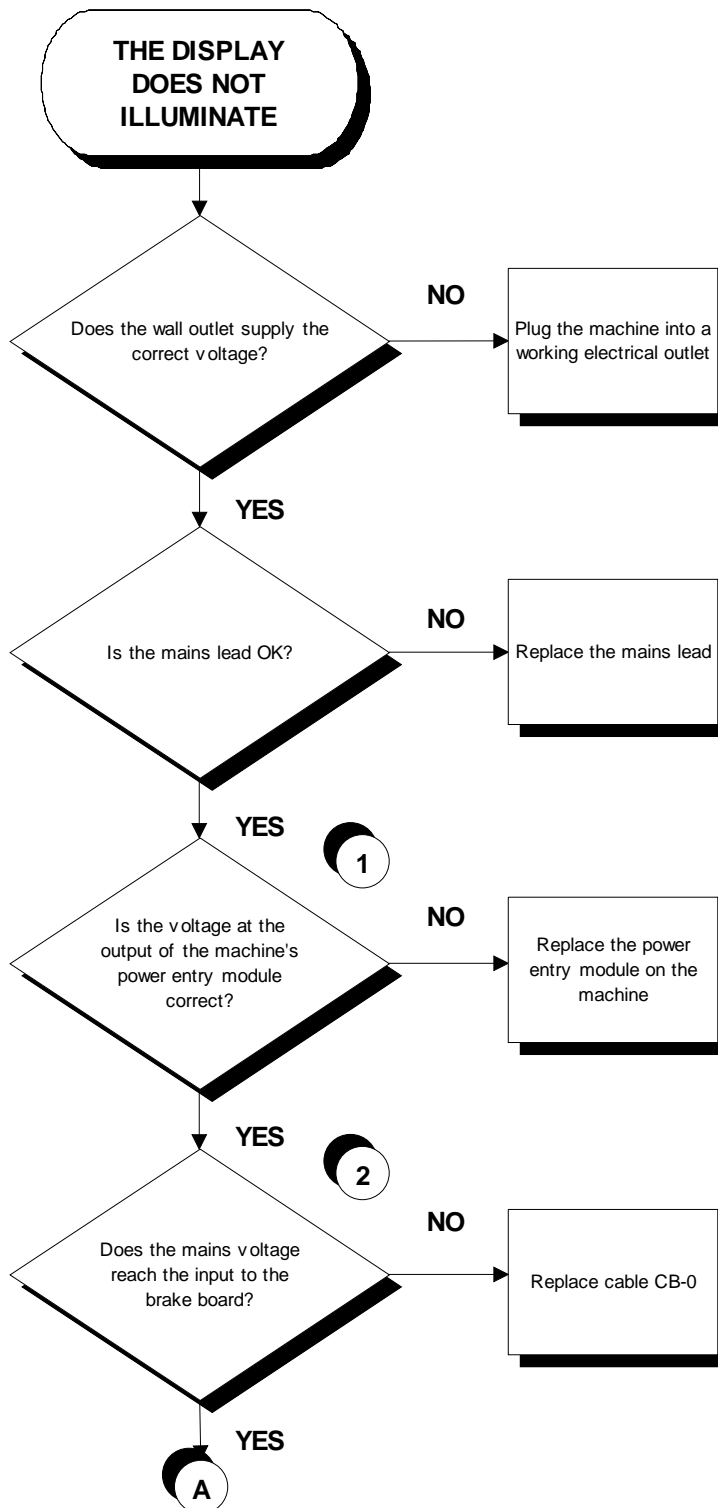

Continued on the following page.

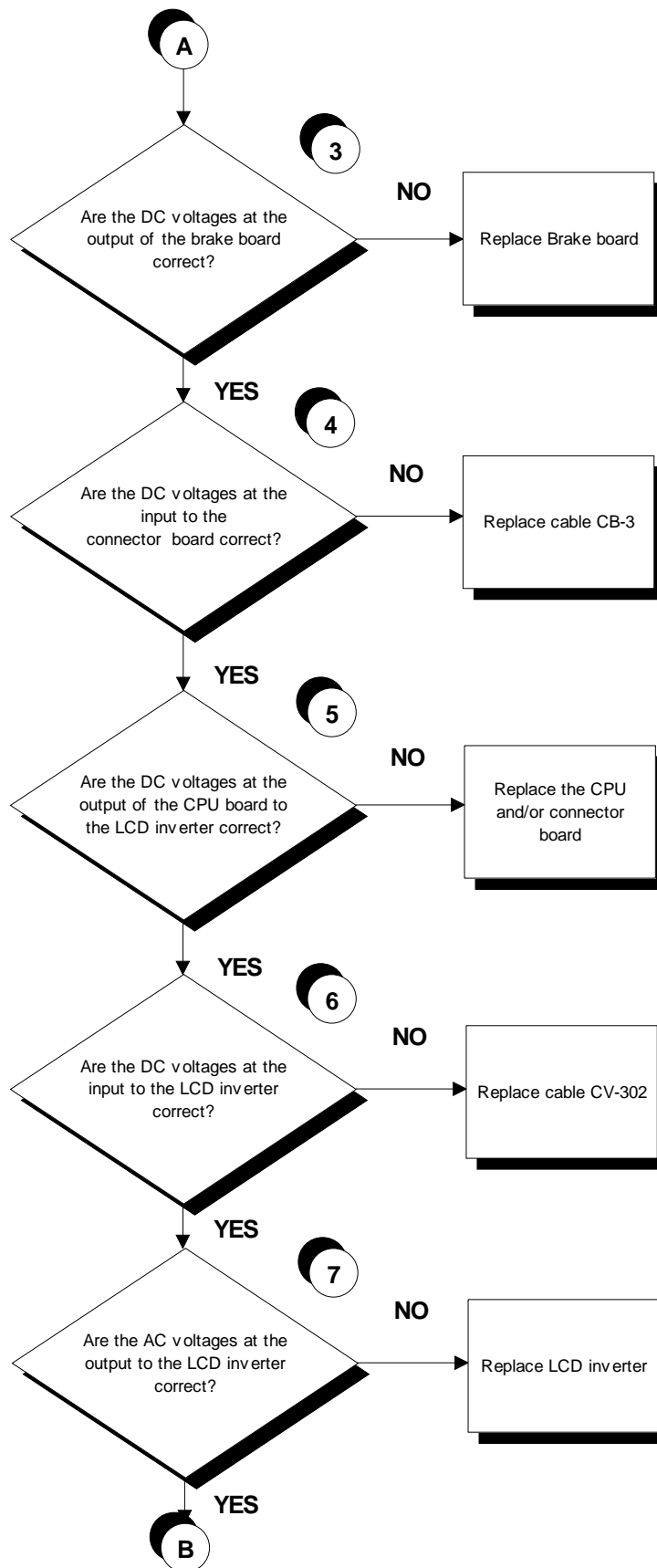

Continued on the following page.

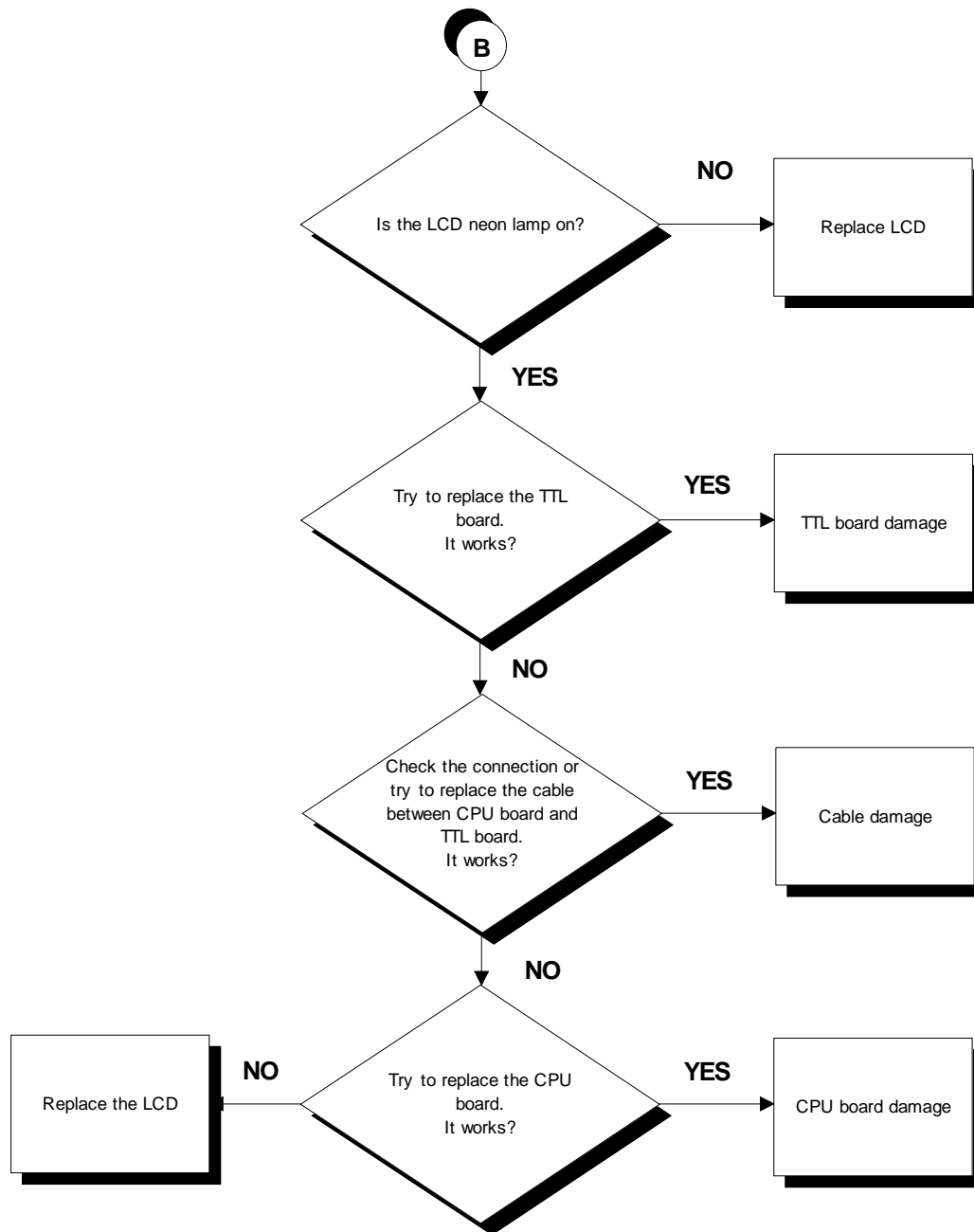

Follow the procedure step by step to correctly diagnose the problem. Take particular care with the checks highlighted by circled numbers, which are described in detail below:



To speed up the troubleshooting procedure, check the state of the power indicator LEDs on the various circuit boards.

- (1) Place the tester probes across the ends of the cable from the alternator. The measured voltage should be approximately 220 VAC or 110 VAC depending on the mains voltage.
- (2) As for step (1) but across pins 1 and 2 of connector CN3 on the brake board.

-
- (3) Using a tester, check that all the output voltages on connector CN1 of the brake board are correct, referring to paragraph 2.8. "Cables".
 - (4) As for step (3) but on connector CN16 on the connector board.
 - (5) As for step (3) but on connector CN5 on the CPU board.
 - (6) As for step (3) but on connector CN1 on the LCD inverter board.
 - (7) Place the tester probes across the 2 pins of the connector CN2 and CN3 of the LCD inverter board. The measured voltage should be approximately 380 VAC.

6.4. NO AUDIO SOUND

This error can be due to incorrect machine configuration, or to problems with the audio signal.

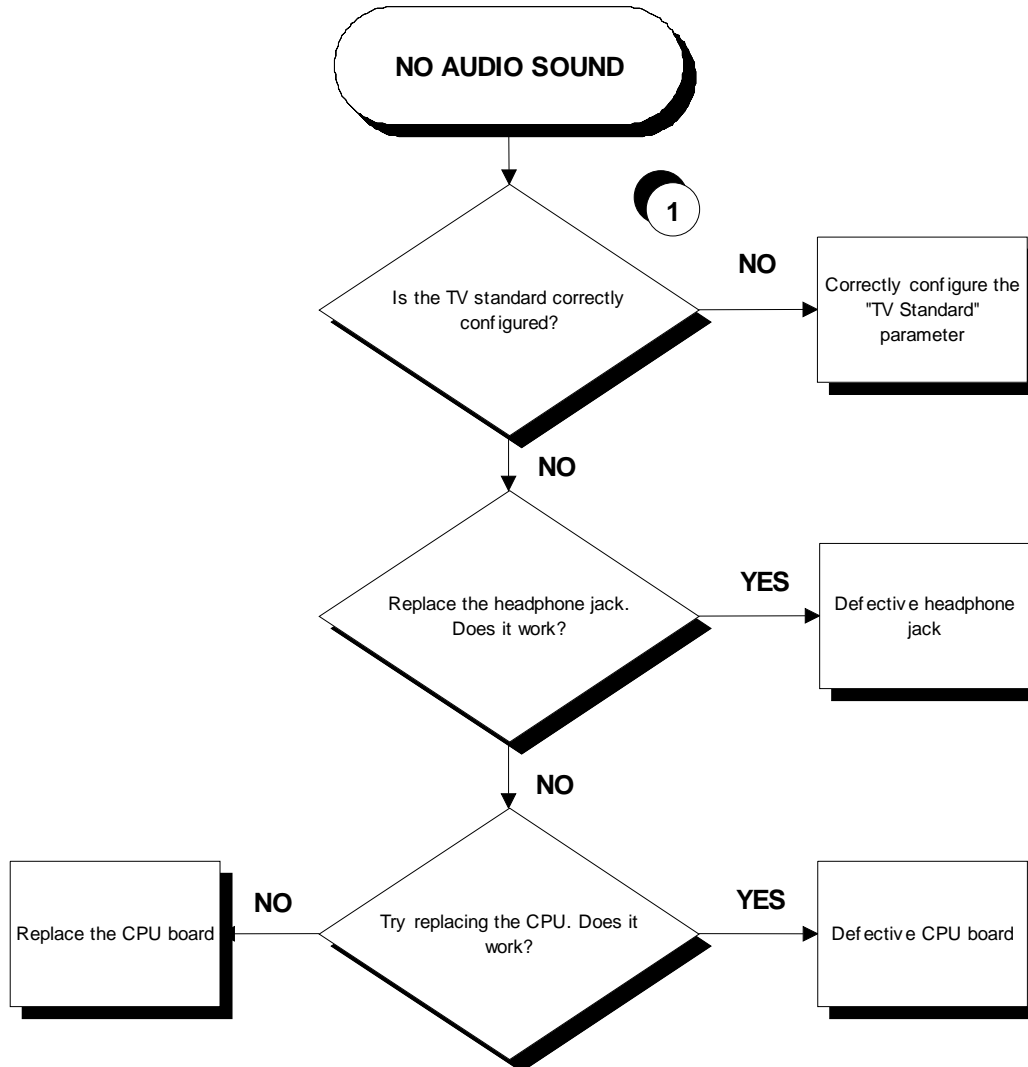

Follow the procedure step by step to correctly diagnose the problem. Take particular care with the checks highlighted by circled numbers, which are described in detail below:

- (1) Carry out the procedure for testing the serial communications described in paragraph 9.3.8. "TV Standard (700E version only)".

6.5. NO TV PICTURE



Check that the machine is connected to an antenna signal

This error can be due to incorrect machine configuration, or to problems with the antenna signal.

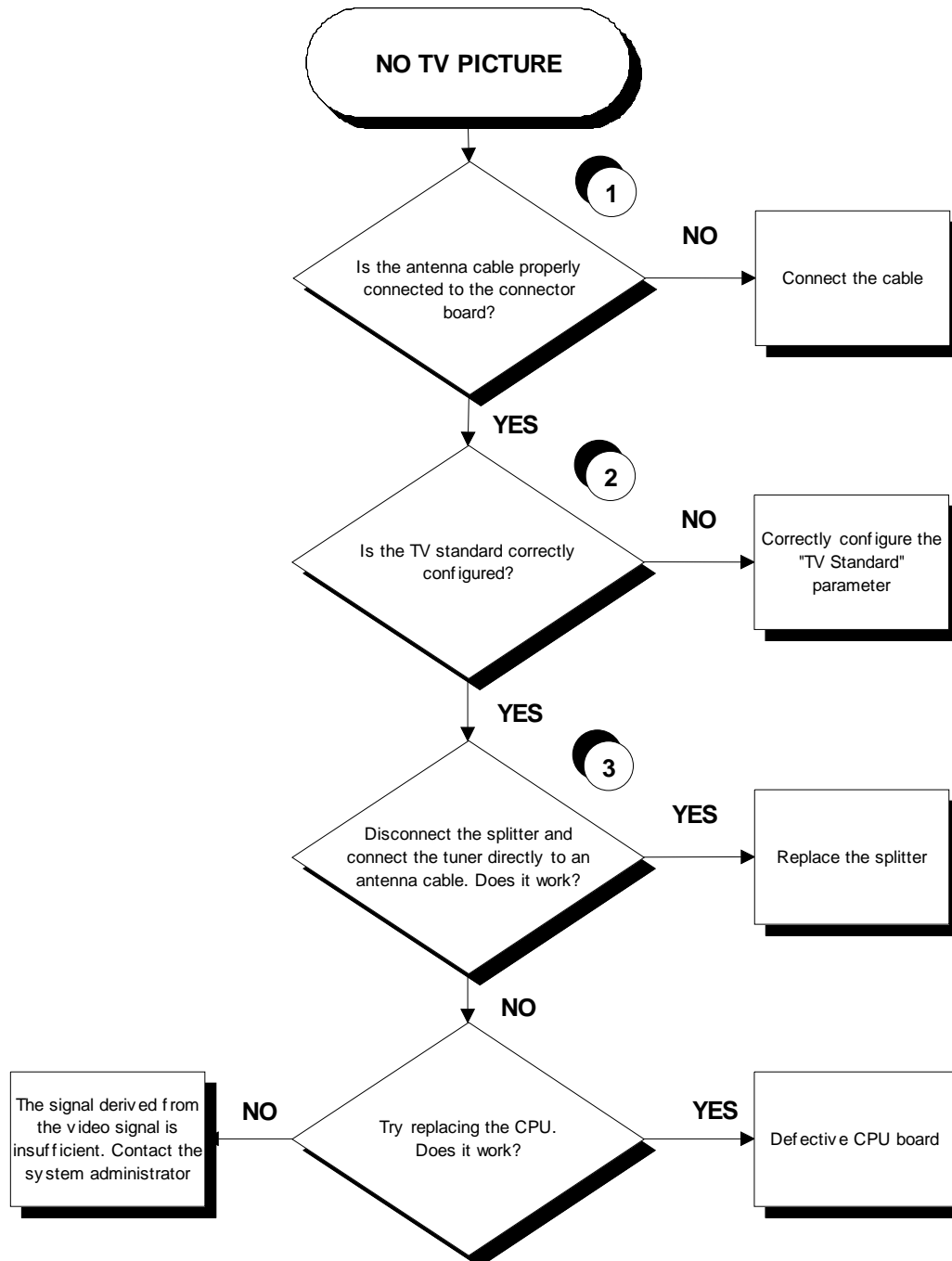

Follow the procedure step by step to correctly diagnose the problem. Take particular care with the checks highlighted by circled numbers, which are described in detail below:

- (1) Check that the antenna cable is correctly connected to connector J1 on the connector board.
- (2) Carry out the configuration procedure described in paragraph 9.3.8. “TV Standard (700E version only)”.
- (3) For models with European electronics, unplug the antenna cable from the connector board and plug it into the tuner; while for models with US electronics, plug the external antenna cable into the tuner.

6.6. THE RADIO DOES NOT PLAY



The radio signal can only be acquired from an analog antenna signal. If the machine is connected to a digital source it will be impossible to use the radio function.

This error can be due to an incorrect machine configuration, or to problems with the antenna signal.

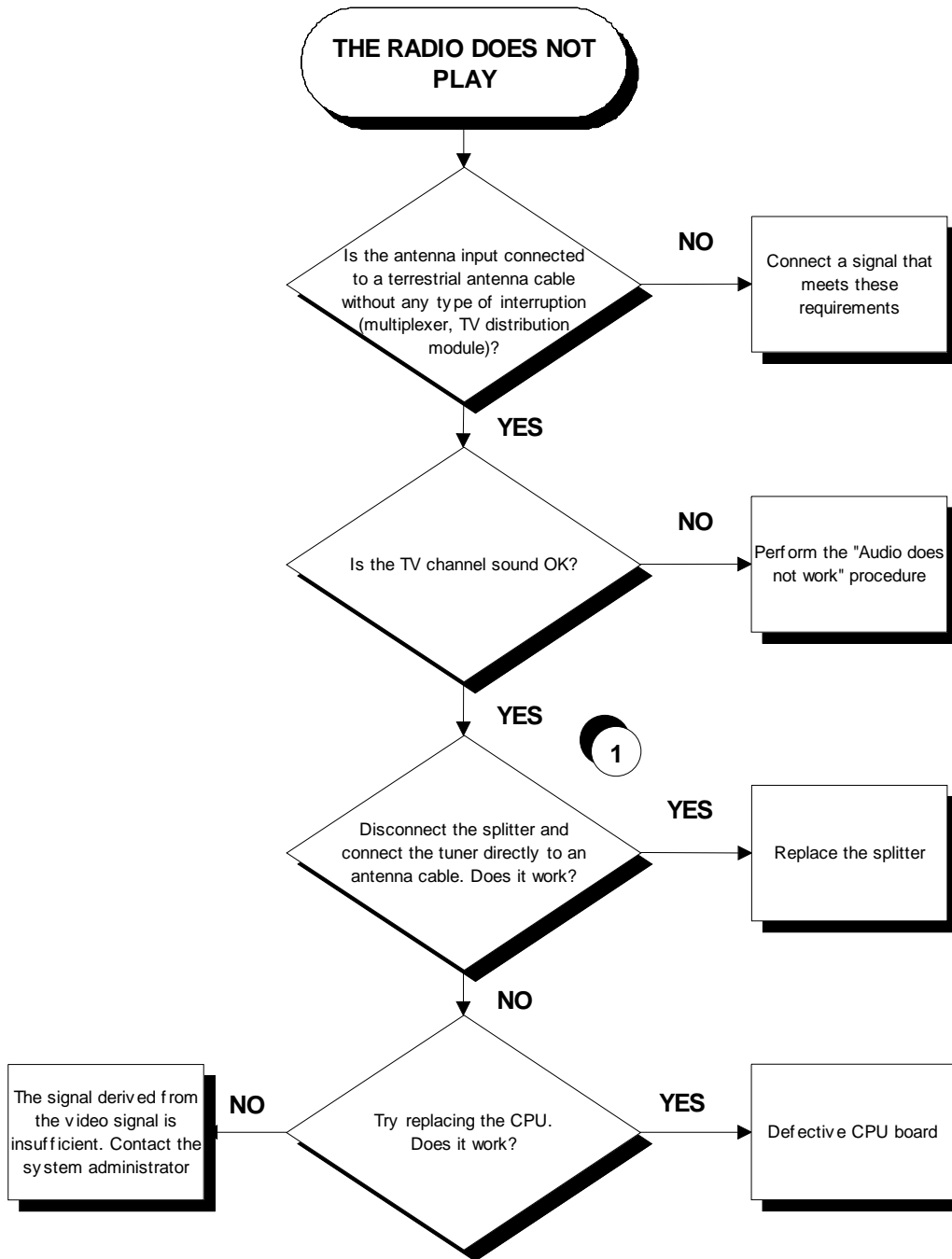

Follow the procedure step by step to correctly diagnose the problem. Take particular care with the checks highlighted by circled numbers, which are described in detail below:

- (1) After disconnecting the splitter from the tuner, procure a female RC connector and a copper wire about 1.5 m long. Connect the copper wire to the tuner through the RC connector, so that it serves as an antenna.

6.7. “THE EQUIPMENT IS BLOCKED” MESSAGE ON THE DISPLAY

This error message can be caused by:

- loss of communication between the lower and upper assemblies;
- the brake board has detected an error condition, causing it to generate an alarm and store the error code in memory.

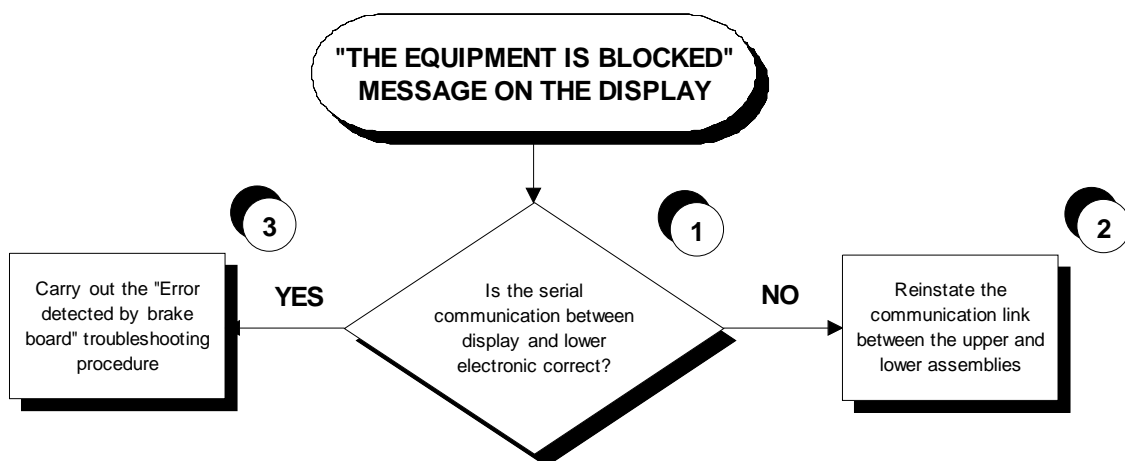

Follow the procedure step by step to correctly diagnose the problem. Take particular care with the checks highlighted by circled numbers, which are described in detail below:

- (1) Use the serial communications test described in paragraph 6.1.1.3 “Serial Ports Test”.
- (2) To reinstate communications between the lower and upper assemblies:
 - check that cable CB-4 is correct;
 - try replacing the brake board and the digital plan board in turn, and check whether the communication works.
- (3) Check whether the brake interface board is in an error condition, by accessing the “Low kit fault code” parameter in the “Low kit menu” described in paragraph 9.3.6.2 “Low Kit fault code”.
If the displayed parameter value is “0”, there is no error condition.

6.8. ERROR DETECTED BY BRAKE BOARD

When the brake board detects an error, it stops and interrupts the power supply to the brake winding, and an error code identifying the fault condition is saved in the error history log. When this error is received by the digital plan board, it halts the exercise and shows the “THE EQUIPMENT IS BLOCKED” message on the display.

The errors logged by the brake board can also be viewed from the machine keyboard as described in paragraph 9.3.4. “Errors log” or in paragraph 9.3.6.2 “Low Kit fault code”.

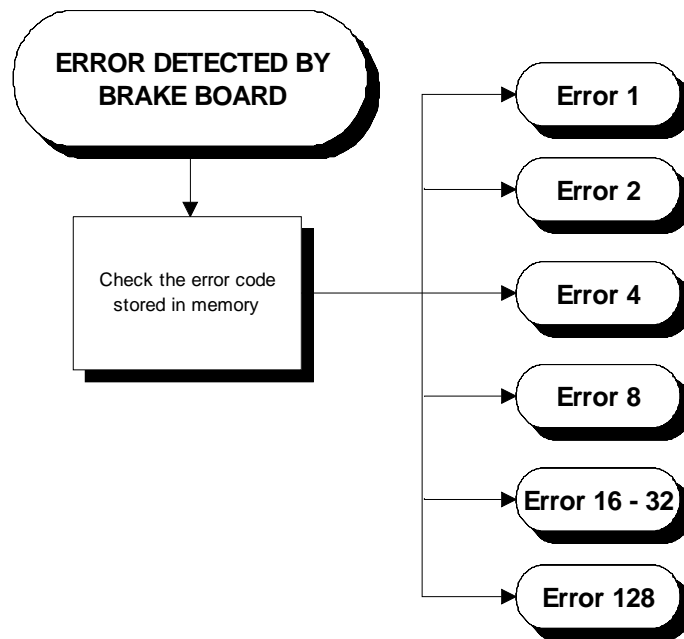

The following paragraphs describe the troubleshooting procedures for these cases.

6.8.1. ERROR 1 ON BRAKE BOARD

This code indicates an overheating error: this condition occurs when the temperature detected by the sensor on the circuit board exceeds 90°C.

Try switching the machine off for 1 hour. If it resumes working correctly, the machine probably overheated as a result of intensive use. If, on the other hand, the error persists, it is necessary to replace the brake board.

6.8.2. ERROR 2 ON BRAKE BOARD

This code indicates an overcurrent error: this condition occurs when the current going to the solenoid measured by the board exceed the max value

This error is caused by an HW problem on the brake board or a short circuit on the solenoid. To solve the problem, it is necessary to replace the brake board or the solenoid.

6.8.3. ERROR 4 ON BRAKE BOARD

This code indicates a low voltage error: this condition occurs when the +12 Vdc voltage drops below 9.7 Vdc.

This error is caused by drops in the voltage output by the power supply section of the brake board, as a result of defective components. If the error persists or recurs frequently, replace the brake board.

6.8.4. ERROR 8 ON THE BRAKE BOARD

This code indicates an overvoltage error: this condition occurs when the +12 Vdc voltage exceeds 13.7 Vdc.

This error is caused by surges in the voltage output by the power supply section of the brake board, as a result of defective components. If the error persists or recurs frequently, replace the brake board.

6.8.5. ERROR 16 OR 32 ON THE BRAKE BOARD

This code indicates an error in the EPROM of the brake board or a watch dog error: this condition occurs when the board is unable to read the memory.

If the error persists or recurs frequently, replace the brake board.

6.8.6. ERROR 128 ON BRAKE BOARD

This code indicates an error in the calibration of the brake board: this condition occurs when the value of the calibration parameter read by the board is incorrect. In these conditions, the board continues to function but will not necessarily produce the correct value of exercise resistance.

When this error occurs, replace the brake board.

6.9. THERE IS NO RESISTANCE

The machine will not produce resistance if:

- the digital plan board does not receive a speed signal;
- the brake board does not generate current;
- the brake is defective.

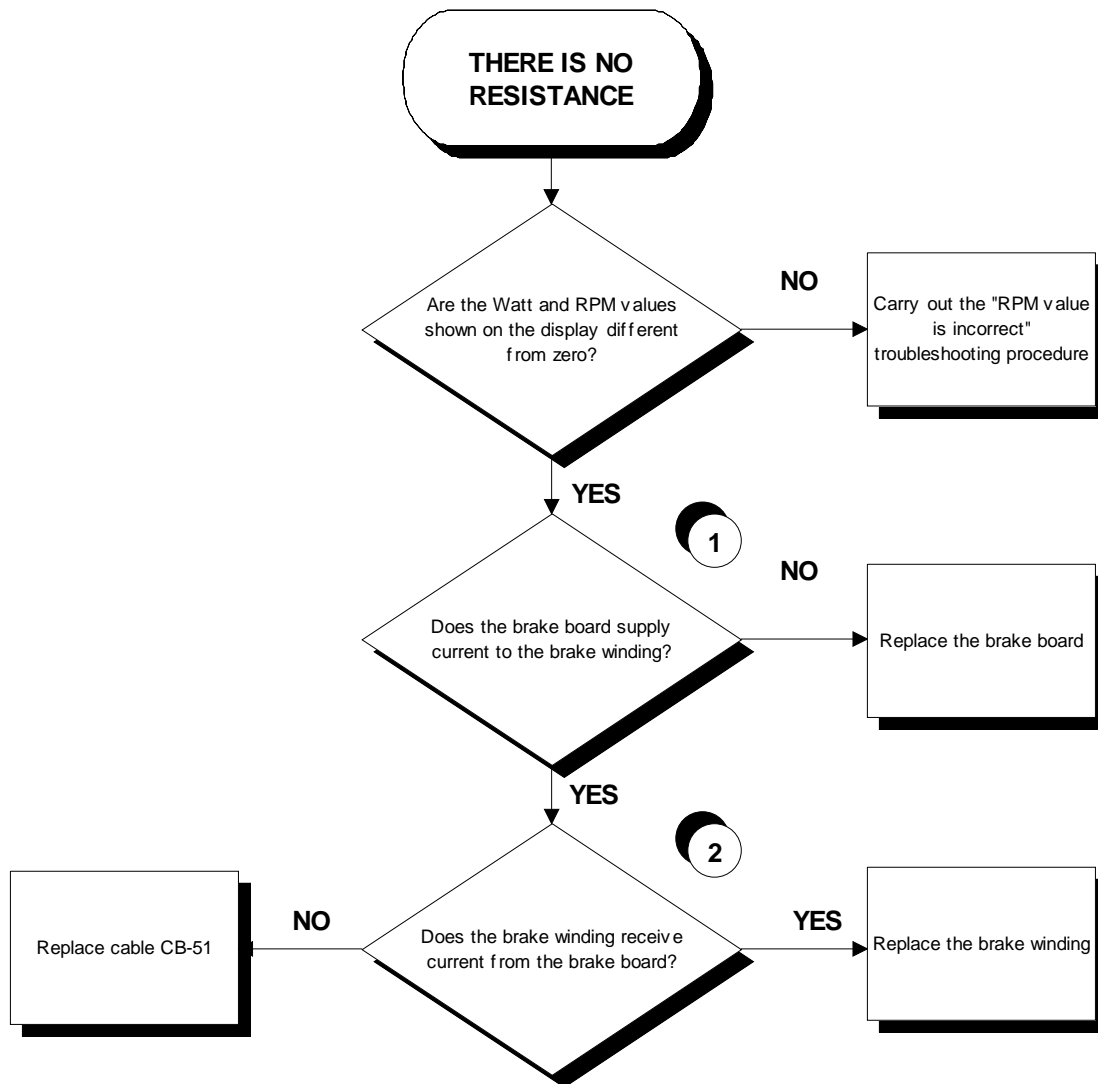

Follow the procedure step by step to correctly diagnose the problem. Take particular care with the checks highlighted by circled numbers, which are described in detail below:

- (1) Disconnect the brake winding and measure the current output by the brake board with a load of at least 5 Ohm and 80 Watts. The value should be different from 0 A.
- (2) As for step (1) but with everything reconnected, and across the brake winding.

6.10. THE RESISTANCE IS INCORRECT

The machine will produce an incorrect resistance if:

- the mechanics are not in perfect condition;
- the speed measurement is incorrect;
- the brake board is defective;
- the brake is defective.

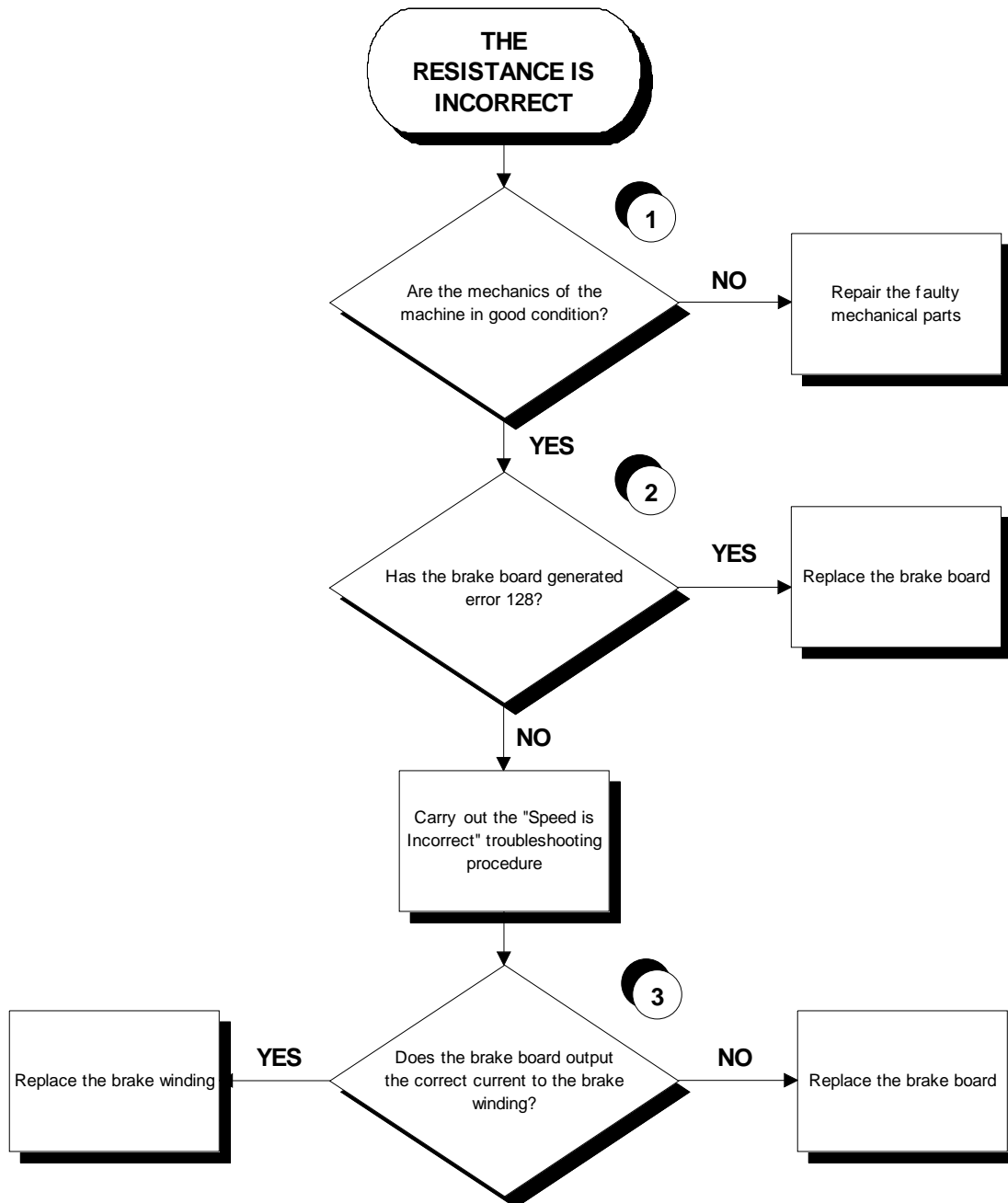

Follow the procedure step by step to correctly diagnose the problem. Take particular care with the checks highlighted by circled numbers, which are described in detail below:

- (1) Check that the mechanical system, consisting of the pedals, belt and brake, moves smoothly and without unusually high friction or resistance.
- (2) Refer to paragraph 9.3.4. “Errors log”.
- (3) Measure the voltage supplied by the brake board to the winding. In constant power mode (custom – time), pedaling at 80 RPM and with a user weighing 75 kg, the values, according to the firmware version of the brake board, should be approximately those in the tables below:

Low kit version 9.57.11	
Power (Watt)	Voltage (Vdc)
50	2.4
80	3.3
150	4.7
200	5.9

Low kit version 9.57.12	
Power (Watt)	Voltage (Vdc)
50	2.0
80	2.9
150	4.4
200	5.3

Low kit version 9.57.13	
Power (Watt)	Voltage (Vdc)
50	2.0
80	2.9
150	4.1
200	4.8

6.11. THE SPEED SIGNAL IS INCORRECT

The speed signal is incorrect if:

- The brake disk is incorrectly fixed to the flywheel;
- The speed sensor is defective;
- The brake board is defective.

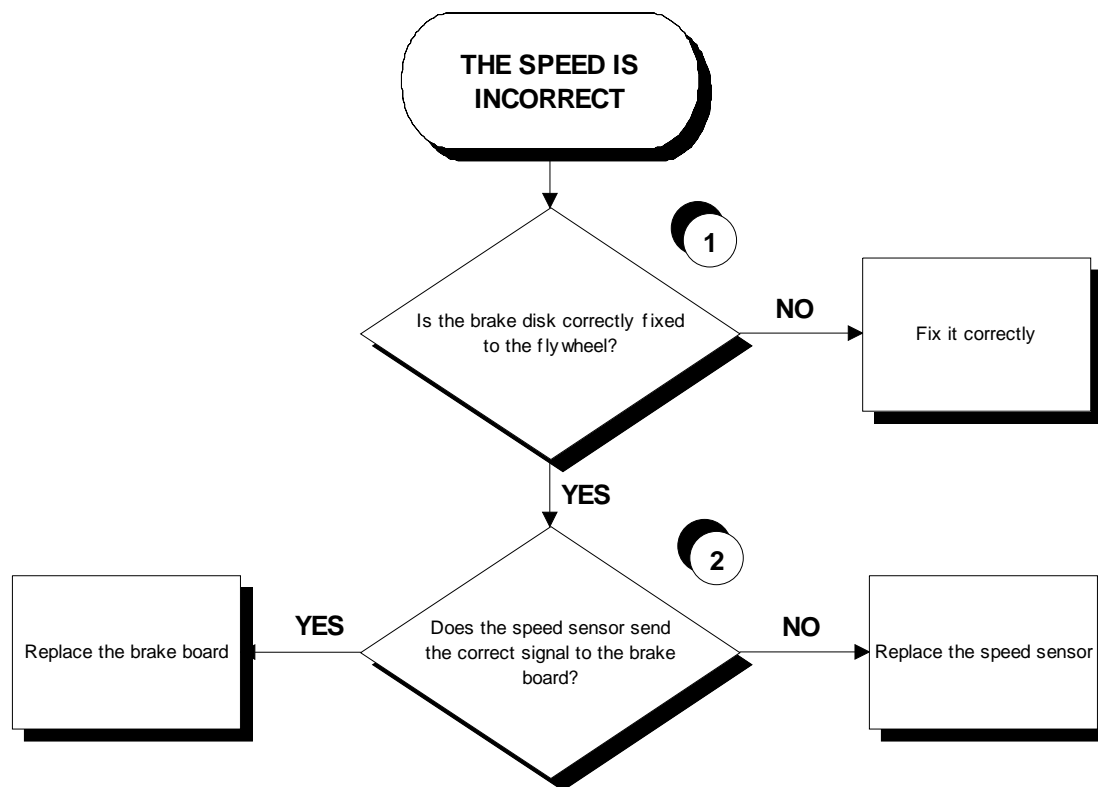

Follow the procedure step by step to correctly diagnose the problem. Take particular care with the checks highlighted by circled numbers, which are described in detail below:

- (1) Check that the 6 screws fixing the disk brake to the flywheel are all locked down.



The speed sensor detects the heads of these screws.

- (2) Place the tester probes across the terminals of the speed sensor. The measured signal should be that indicated in Figure 3.2-1. In addition, when pedaling at 80 RPM the frequency of the signal should be 107 Hz.



The speed signal can also be observed qualitatively, using a multimeter. The value should be 0 Vdc when the machine is stopped, and gradually increase as the speed increases.

6.12. THE MACHINE DOES NOT READ THE TGS/SMART CARD

The machine displays this error if the TGS or Smart Card reader is not working properly, or if it is not supplied by the digital plan board.

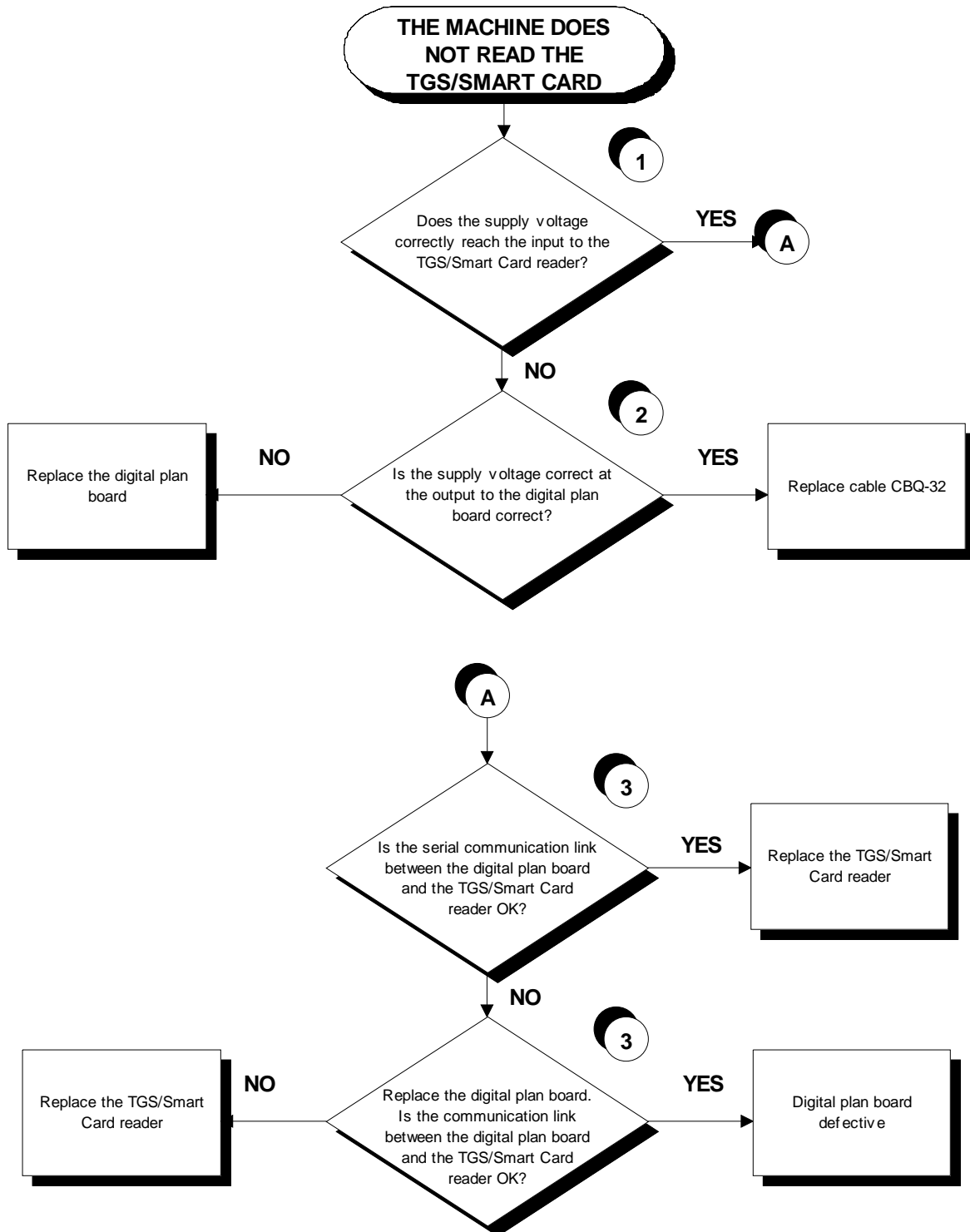

Follow the procedure step by step to correctly diagnose the problem. Take particular care with the checks highlighted by circled numbers, which are described in detail below:

-
- (1) Place the tester probes across pins 1 and 3 of connector CN1 of the TGS/Smart Card reader. The measured value should be +12 Vdc.
 - (2) As for step (1) but across pins 1 and 9 of connector CN10 on the digital plan board.
 - (3) Use the serial communications test described in paragraph 6.1.1.3 “Serial Ports Test”.

6.13. THERE IS NO HEART RATE SIGNAL

6.13.1. RICEVITORE TELEMETRICO HFU

The machine displays this error if the receiver is not working properly, or if it is not supplied by the display board.



Only for the 500 and 500SP models.

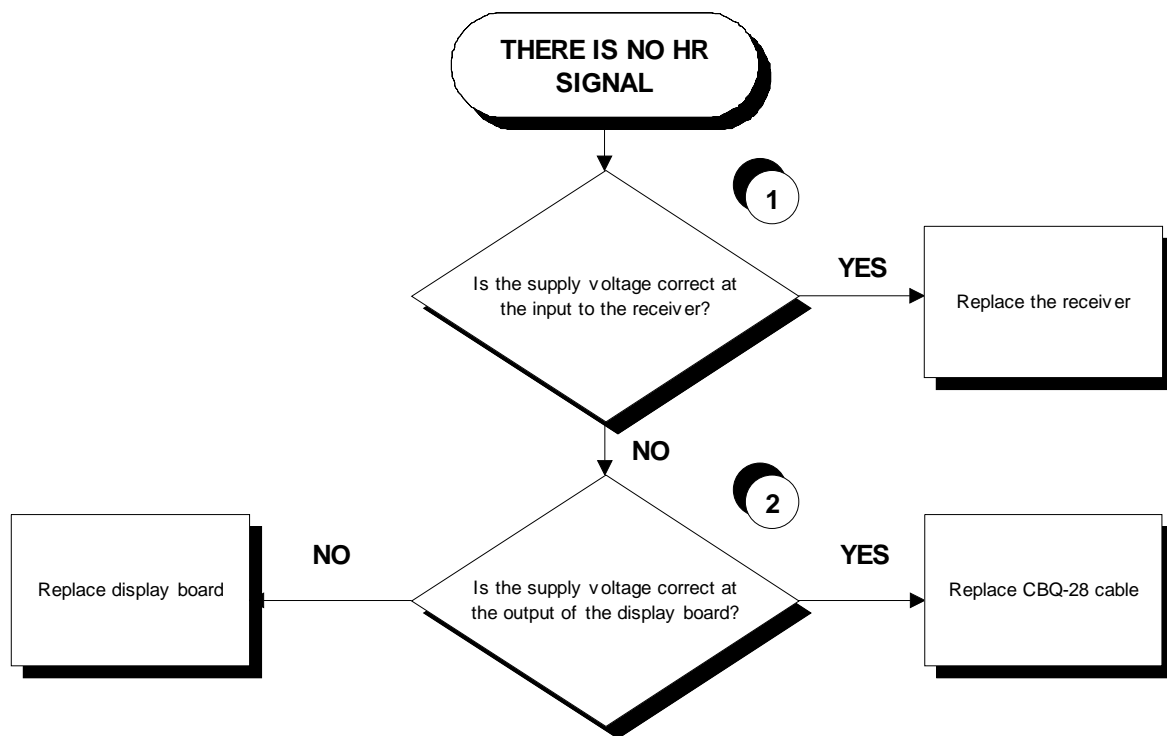

Follow the procedure step by step to correctly diagnose the problem. Take particular care with the checks highlighted by circled numbers, which are described in detail below:

- (1) Place the tester probes across pins 1 and 3 of connector CN1 of the receiver. The measured value should be +5 Vdc.
- (2) As for step (1) but across pins 1 and 8 of connector CN8 on the display board.

6.13.2. OWNZONE TELEMETRICO RECEIVER

The machine displays this error if the receiver is not working properly, or if it is not supplied by the digital plan board. It may also be caused by communication problems between the digital plan board and the OwnZone receiver, which communicate with each other by means of an I²C protocol.



Only for the 700, 700E and 700SP models.

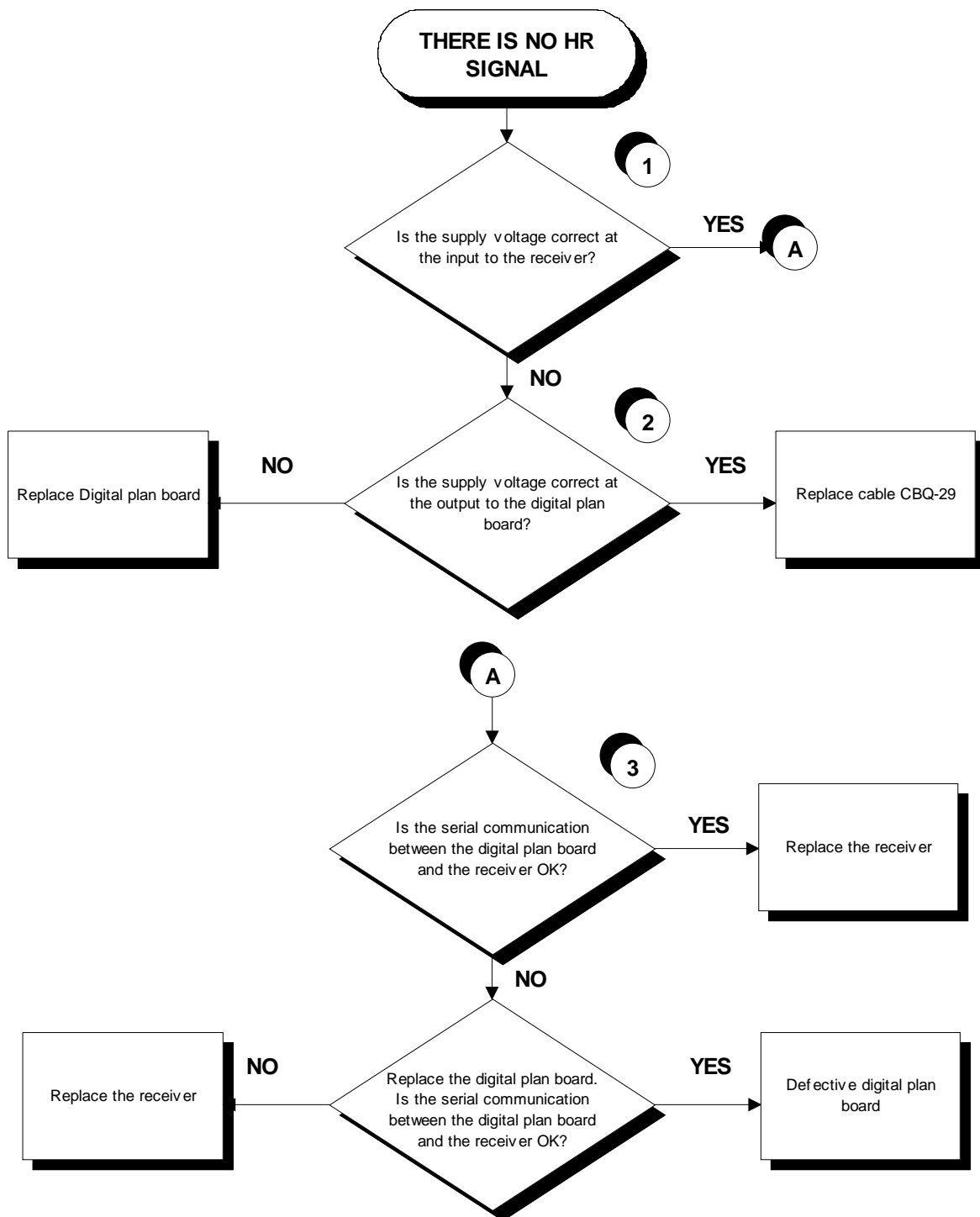

Follow the procedure step by step to correctly diagnose the problem. Take particular care with the checks highlighted by circled numbers, which are described in detail below:

- (1) Place the tester probes across pins 4 and 5 of connector CN1 of the receiver. The measured value should be +5 Vdc.
- (2) As for step (1) but across pins 1 and 8 of connector CN11 on the digital plan board.
- (3) Use the serial communications test described in paragraph 6.1.1.1 "I2C Devices Test".

6.13.3. HAND SENSOR

The machine displays this error if the HS interface board is not working, or if it is not supplied by the digital plan board.

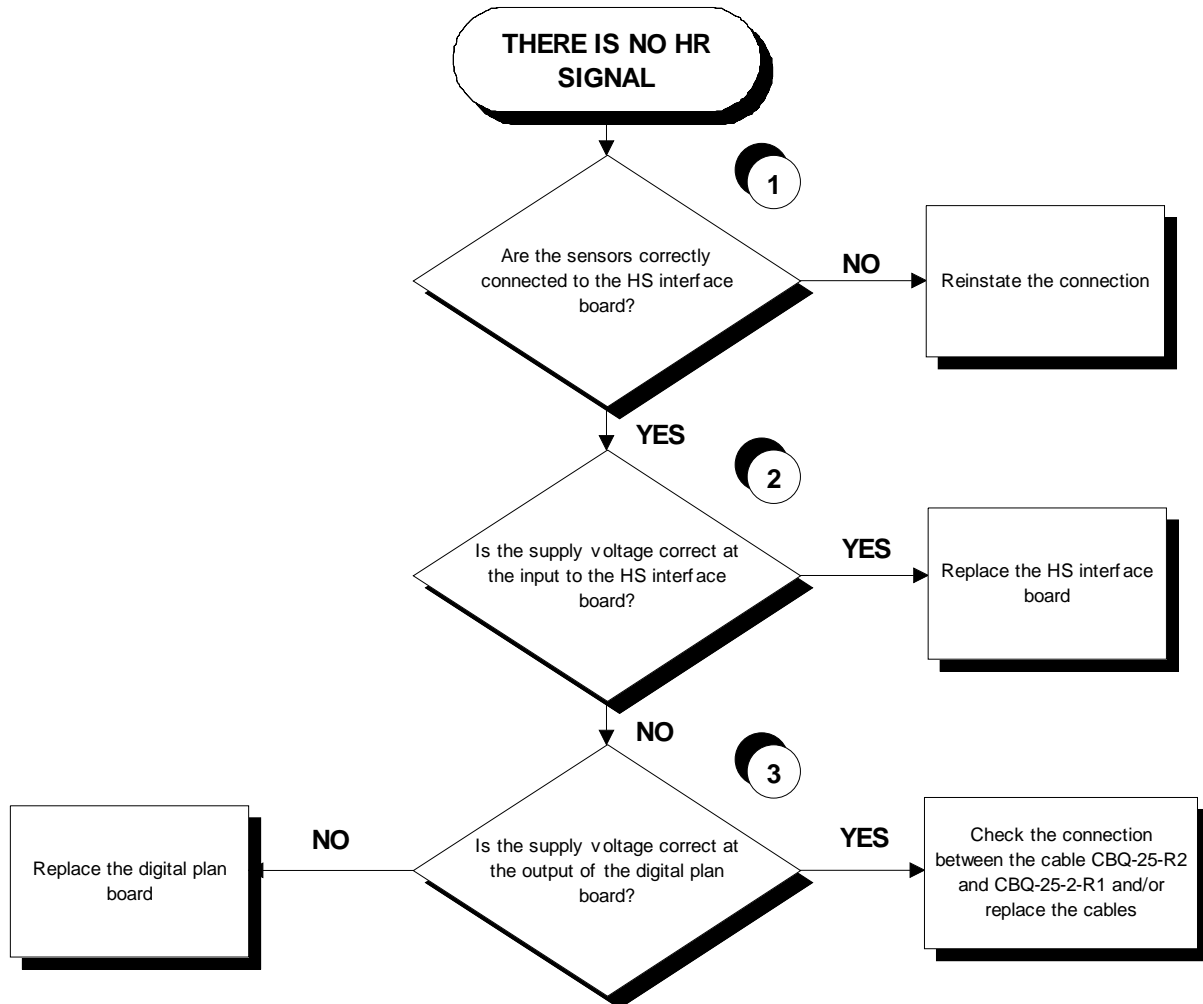

Follow the procedure step by step to correctly diagnose the problem. Take particular care with the checks highlighted by circled numbers, which are described in detail below:

- (1) Check the connections, referring to paragraph 2.7. “Wiring diagram”.
- (2) Place the tester probes across pins 2 and 1 of connector J3 on the HS interface board. The measured value should be +5 Vdc.
- (3) As for step (2) but across pins 1 and 6 of connector CN13 on the digital plan board.

6.14. THE TELEMETRIC HR SIGNAL IS INCORRECT

The machine displays this error if the receiver is disturbed by sources of electromagnetic noise.

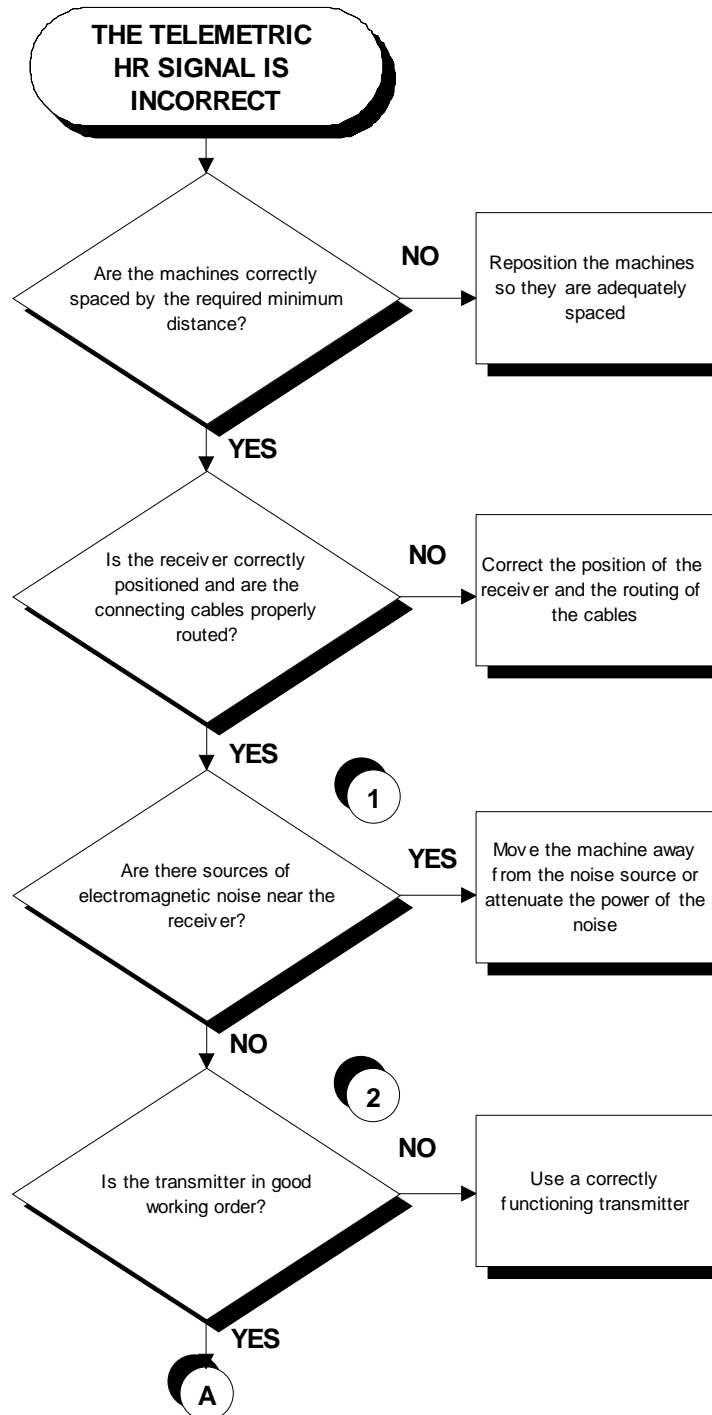

Continued on the following page.

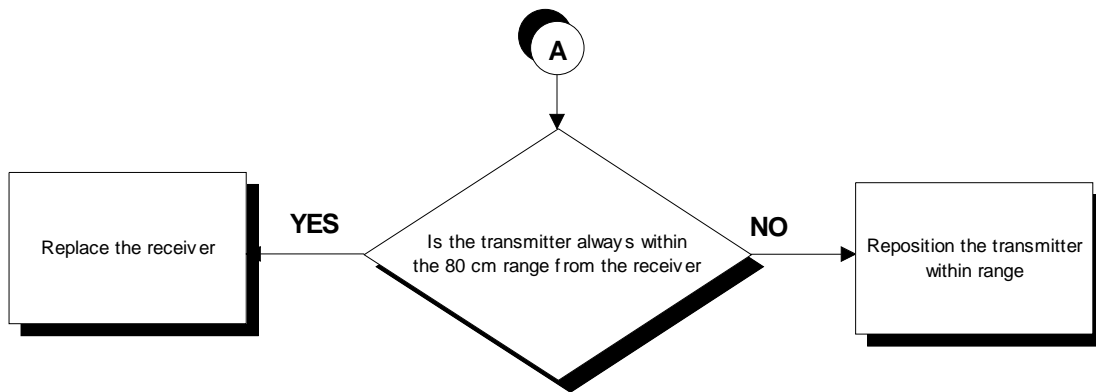

Follow the procedure step by step to correctly diagnose the problem. Take particular care with the checks highlighted by circled numbers, which are described in detail below:

- (1) To check for electromagnetic noise near the machine, use a frequency signal monitor constructed as shown in the diagram below.

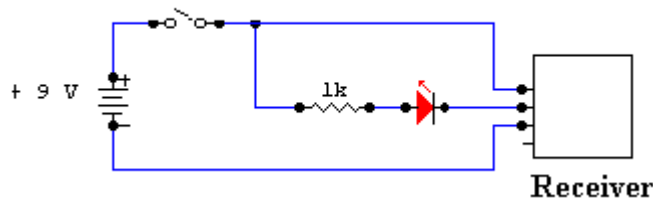

The circuit lights the LED for each heart beat and/or disturbance received: in this way it is possible to determine whether there is any interference, and identify its sources.

- (2) Check the battery power level, using a tester if possible. Otherwise use a receiver or another "reference" machine to check the operation up to a distance of about 80 cm from the receiver.

7. DISASSEMBLY OF COMPONENTS

7.1. DISASSEMBLING THE DISPLAY

7.1.1. 700 AND 700SP LED VERSIONS



Figure 7.1-1



Figure 7.1-2

1. Turn off the machine and unplug the mains lead from the wall outlet (only for the 700 models).
2. Back off the 6 screws **a** using a medium Phillips screwdriver.
3. Unplug the 4 connectors indicated in the figure at left.
4. Remove the display.

Continued on following page →

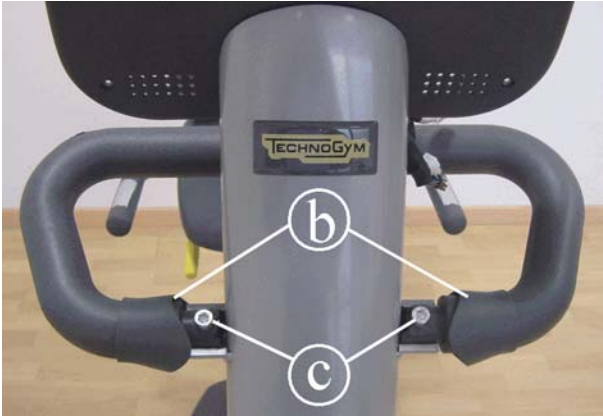

Figure 7.1-3

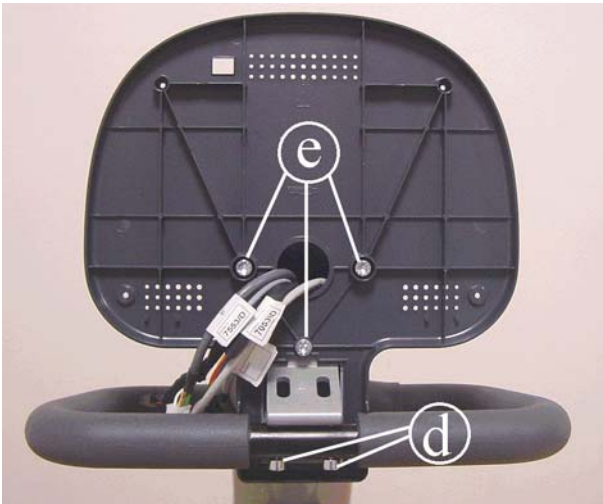

Figure 7.1-4

5. Shift the rubber bushings **b**.
6. Back off the 2 grab screws **c** using a 6-mm Allen wrench.

7. Back off the 2 screws **d**, using a 6-mm Allen wrench.
8. Remove the handlebar.
9. Back off the 3 screws **e**, using a 6-mm Allen wrench, to remove the rear display support.

To reassemble the display, carry out the above steps in reverse order.

■ During reassembly, lock down the screws **c** and **d** using a torque wrench set for 22 Nm.

7.1.2. 700E WELLNESS TV VERSION



Figure 7.1-5



Figure 7.1-6



Figure 7.1-7

1. Turn off the machine and unplug the mains lead from the wall outlet.
2. Back off the 2 screws **a**, using a medium Phillips screwdriver, to remove the input AUX / CSAFE board support.
3. Unplug the connectors indicated in the figure, connected to the input AUX / CSAFE.
4. Back off the 4 screws **b** fixing the display to the machine, using a medium Phillips screwdriver.

Continued on following page →

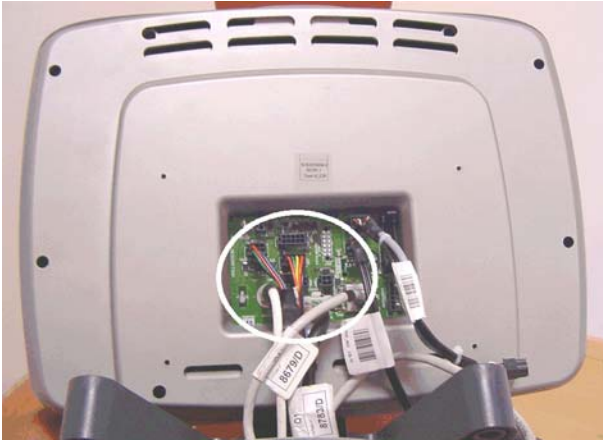

Figure 7.1-8

5. Hold the display and disconnect from the connector board the highlighted cables.
6. Remove the LCD display.

To reassemble the display, carry out the above steps in reverse order.

7.1.3. 500 AND 500SP LED VERSIONS



Figure 7.1-9



Figure 7.1-10

1. Turn off the machine and unplug the mains lead from the wall outlet (only for the 500 models).
2. Back off the 6 screws **a** using a medium Phillips screwdriver.

3. Unplug the connectors indicated in the figure at left.
4. Remove the display.

Continued on following page →



Figure 7.1-11

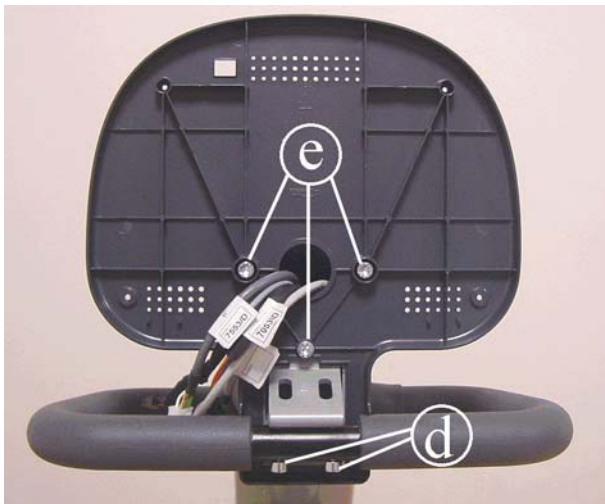



Figure 7.1-12

5. Shift the rubber bushings **b**.
6. Back off the 2 grab screws **c** using a 6-mm Allen wrench.

7. Back off the 2 screws **d**, using a 6-mm Allen wrench.
8. Remove the handlebar.
9. Back off the 3 screws **e**, using a 6-mm Allen wrench, to remove the rear display support.

To reassemble the display, carry out the above steps in reverse order.

 **During reassembly, lock down the screws **c** and **d** using a torque wrench set for 22 Nm.**

7.2. DISASSEMBLING THE CIRCUIT BOARDS ON THE DISPLAY

7.2.1. 700 AND 700SP LED VERSIONS

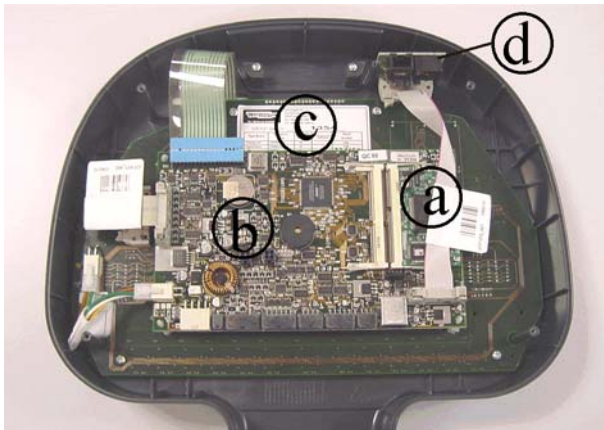

Figure 7.2-1



Figure 7.2-2

Carry out the procedure described in paragraph 7.1. “Disassembling the display”.

Then place the display on a work bench. It is now possible to disassemble its 4 circuit boards:

- The 386 board **a**;
- The digital plan board **b**;
- The LED board **c**;
- The CSafe board **d**.

386 board **a**:

1. Push open the clip fasteners. The 386 board will lift up.
2. Remove it from the connector on the digital plan board.

Digital Plan board **b**:

1. Unplug the connectors indicated in the figure.
2. Release the 4 clips **e**.
3. Remove the circuit board.

Continued on following page →

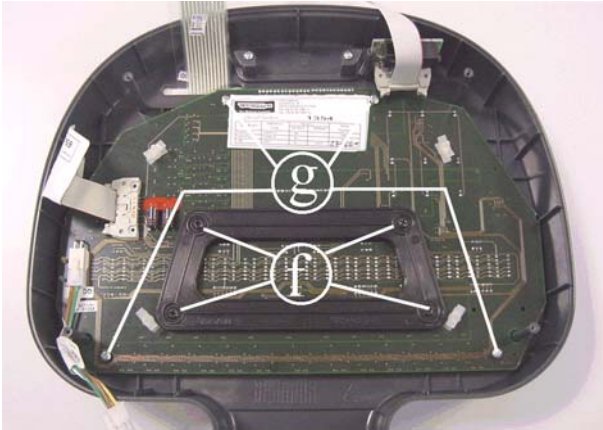

Figure 7.2-3



Figure 7.2-4

LED Board c:

1. Back off the 4 fixing screws **f** of the plastic support, using a medium Phillips screwdriver.
2. Back off the 4 screws **g** using a small Phillips screwdriver.
3. Remove the circuit board.

CSafe board d:

1. Unplug the connector indicated in the figure.
2. Remove the circuit board from the top.

To reassemble the electronics boards, carry out the above steps in reverse order.

7.2.2. 700E WELLNESS TV VERSION

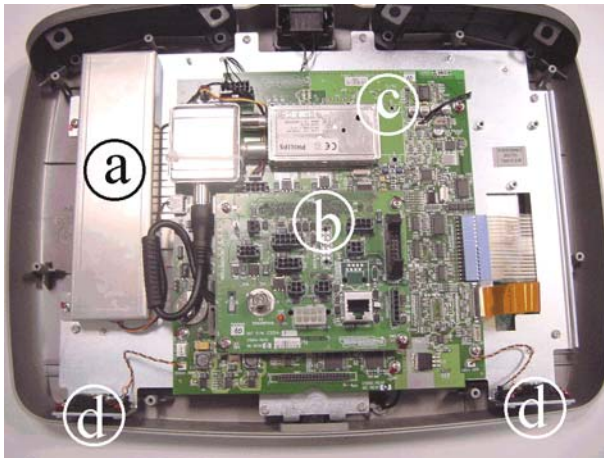

Figure 7.2-5

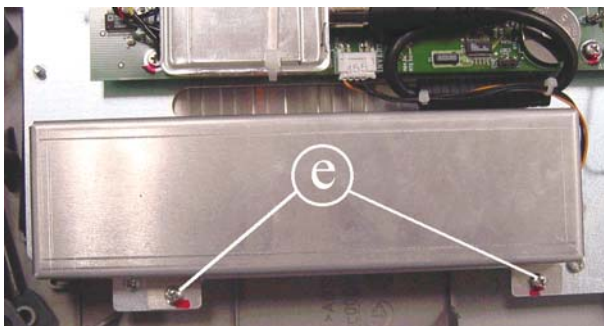

Figure 7.2-6

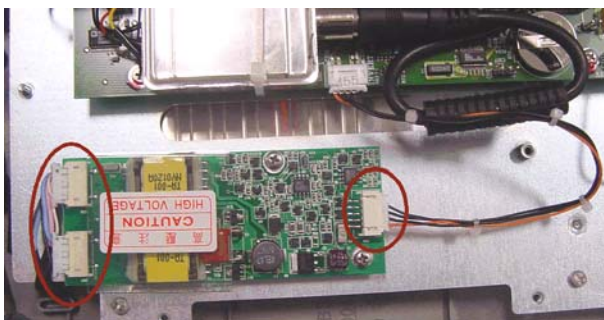

Figure 7.2-7

Carry out the procedure described in paragraph 7.1. “Disassembling the display”.

Then place the display on a work bench. It is now possible to disassemble its circuit boards:

- The LCD inverter **a**;
- The connectors board **b**;
- The CPU board **c**;
- The external speakers **d**.

LCD inverter **a**:

1. Back off the 2 screws **e**, using a Phillips screwdriver.
2. Remove the inverter covering plate.
3. Unplug the connectors indicated.
4. Back off the 2 screws that are fixing the board to the display plate.
5. Remove the LCD inverter.

Continued on following page →

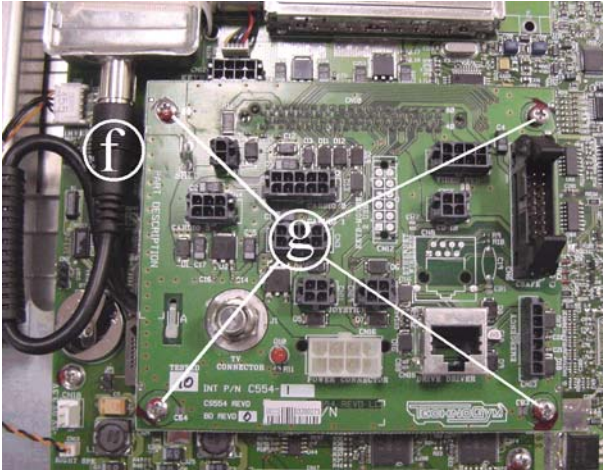

Figure 7.2-8

Connectors board **b:**

1. Unplug the antenna cable **f** going to the splitter.
2. Back off the 4 screws **g** using a small Phillips screw driver.
3. Remove the board from the display, taking care not to damage the connector that connect it to the CPU board.

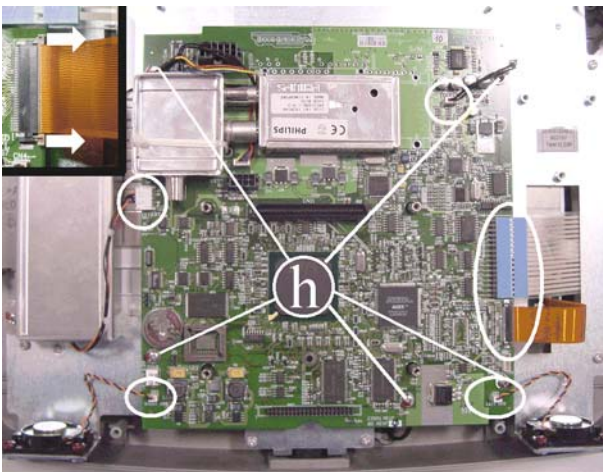

Figure 7.2-9

CPU board **c**

1. Unplug the cables indicated in the figure, coming from TTL board, LCD inverter, keyboard, headphone jack and external speakers.
2. Disconnect the cable coming from the TTL board:
 - Push open the clip fasteners of the connector on the CPU board as shown in the highlight;
 - pull the cable out.
3. Back off the 5 screws **h** using a small Phillips screwdriver.
4. Remove the CPU board.

Speakers **d:**

1. Unplug the cables indicated in the figure from the CPU board.
2. Back off the 4 screws of each speaker, using a small Phillips screwdriver.
3. Remove the speakers.



Figure 7.2-10

Continued on following page →



Figure 7.2-11



Figure 7.2-12



Figure 7.2-13

To disassemble the input AUX / CSafe board and the Hand sensor board:

1. Back off the 2 screws **i**, using a medium Phillips screwdriver, to remove the input AUX / CSafe board support.
2. Unplug the connectors indicated in the figure, connected to the input AUX / CSafe board.
3. Back off the 2 screws **1** to disassemble the input AUX / CSafe board, using a small Phillips screwdriver.

To disassemble the LCD:

1. Unplug the connectors of the cable coming from keyboard, headphone jack, TTL board and LCD (on the inverter), indicated in the figure.
2. Back off the 8 screws indicated in the figure, that are fixing the plate with the circuit boards, to the front display covering.
3. Disconnect the cable coming from the TTL board:
 - Push open the clip fasteners of the connector on the CPU board as shown in the highlight;
 - pull the cable out.

Continued on following page →

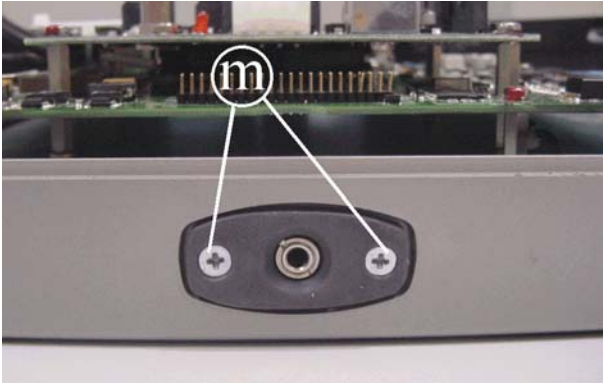

Figure 7.2-14

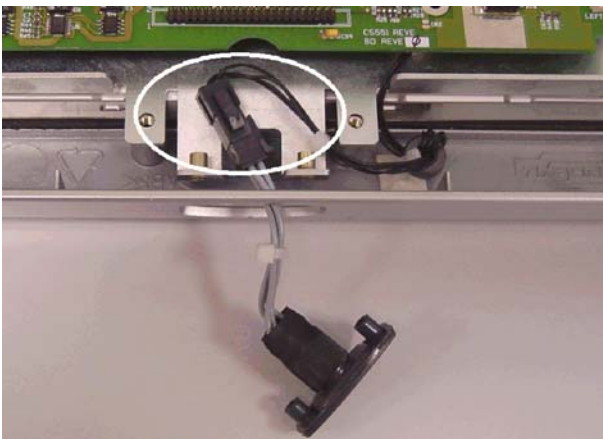

Figure 7.2-15

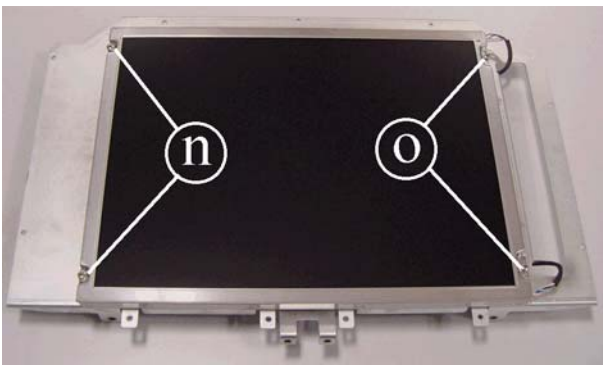

Figure 7.2-16

4. Back off the 2 screws **m** that are fixing the headphone jack, using a small Phillips screwdriver.

5. Pull the connector out of its seat and unplug the connector indicated in the figure

6. Remove the display plate from the front covering.

7. Back off the 2 screws **n** using a small Phillips screwdriver.

8. Back off the 2 screws **o** using a small Phillips screwdriver.

To reassemble the circuit boards and the LCD, carry out the above steps in reverse order.

7.2.3. 500 AND 500SP LED VERSIONS

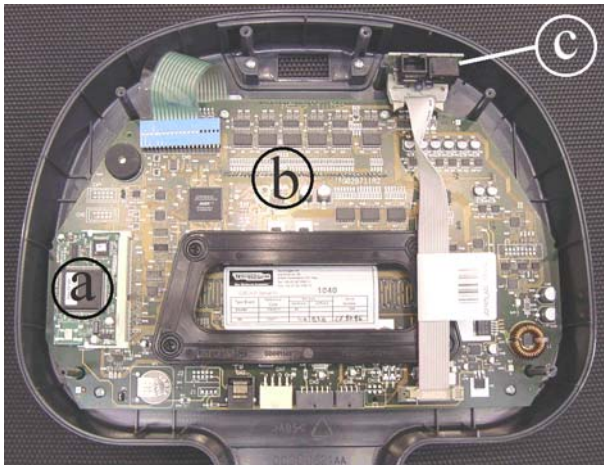

Figure 7.2-17

Carry out the procedure described in paragraph 7.1. “Disassembling the display”.

Then place the display on a work bench. It is now possible to disassemble its circuit boards:

- The 386 board **a**;
- The display board **b**;
- The CSafe board **c**.

386 board **a**:

1. Push open the clip fasteners. The 386 board will lift up.
2. Remove it from the connector on the display board.

Display board **b**:

1. Unplug the connectors **g** and **f**.
2. Back off the 4 screws **d**, using a medium Phillips screwdriver and remove the plastic component.
3. Back off the 4 screws **e**, using a small Phillips screwdriver.
4. Remove the circuit board.

CSafe board **c**:

1. Unplug the connector **g**.
2. Remove the circuit board.

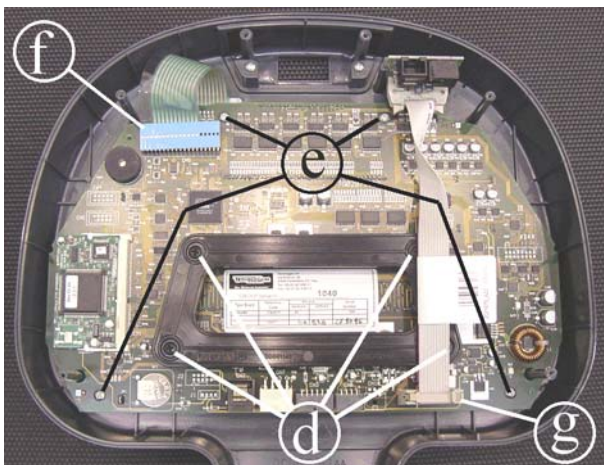

Figure 7.2-18

7.3. DISASSEMBLING THE KEYBOARD

7.3.1. 700 AND 700SP LED VERSIONS



Figure 7.3-1



Figure 7.3-2

Carry out the procedure described in paragraph 7.1. “Disassembling the display”.

1. Unplug the keyboard connector shown in the figure.

With the display placed on a work bench:

2. Use a sharp tool to lift up and detach a corner of the keyboard.

To assemble a new keyboard, with the display on a work bench:

1. Remove the backing film which protects the adhesive.
2. Apply the adhesive part, starting from the left and working toward the right, without bending the keyboard.
3. Insert the connector in the special slot on the display and connect it to the digital plan board.
4. Remove the protective film.

 **When reassembling the keyboard, make sure that none of the keys are bent or remain pushed in.**

 **The keyboard assembly procedure can only be carried out once, because disassembly damages the tracks and keys.**

7.3.2. 700E WELLNESS TV VERSION



Figure 7.3-3

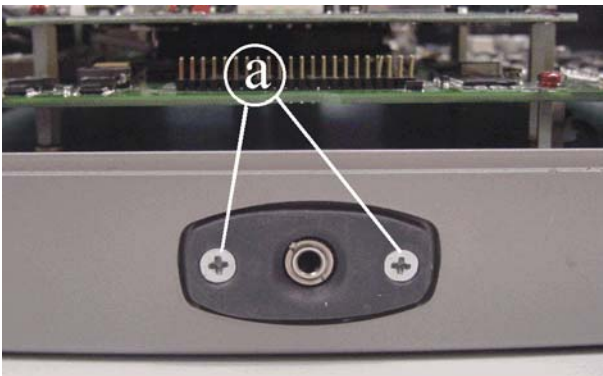

Figure 7.3-4

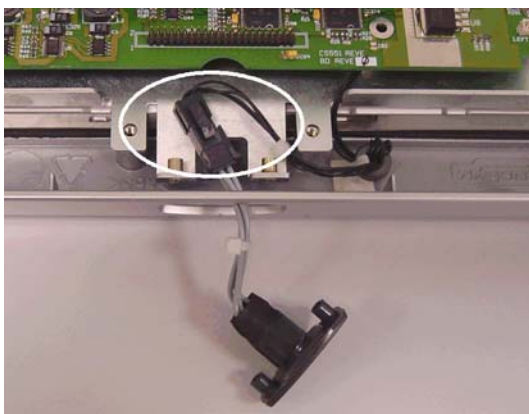

Figure 7.3-5

Carry out the procedure described in paragraph 7.1. “Disassembling the display”.

1. Unplug the 2 connectors of the keyboard and of the headphone jack indicated in the figure.
2. Back off the 8 screws indicated in the figure, that are fixing the plate with the circuit boards, to the front display covering.
3. Back off the 2 screws **a** that are fixing the headphone jack, using a small Phillips screwdriver.
4. Pull the connector out of its seat and unplug the connector indicated in the figure
5. Remove the display plate from the front covering.

Continued on following page →



Figure 7.3-6

6. Lift up and replace the glass **b** on which the keyboard is fixed.

To reassemble the keyboard, carry out the above steps in reverse order.

7.3.3. 500 AND 500SP LED VERSIONS



Figure 7.3-7

Carry out the procedure described in paragraph 7.1. “Disassembling the display”.

1. Unplug the keyboard connector shown in the figure.

With the display placed on a work bench:

2. Use a sharp tool to lift up and detach a corner of the keyboard.

To assemble a new keyboard, with the display on a work bench:

1. Remove the backing film which protects the adhesive.
2. Apply the adhesive part, starting from the left and working toward the right, without bending the keyboard.
3. Insert the connector in the special slot on the display and connect it to the display board.
4. Remove the protective film.



Figure 7.3-8

● When reassembling the keyboard, make sure that none of the keys are bent or remain pushed in.

● The keyboard assembly procedure can only be carried out once, because disassembly damages the tracks and keys.

7.4. DISASSEMBLING THE CARDIO RECEIVER



Figure 7.4-1



Figure 7.4-2

Carry out the procedure described in paragraph 7.1. “Disassembling the display”.

1. Back off the 2 screws **a** using a 3-mm Allen wrench locking down the 2 internal nuts using a 7-mm wrench.

2. Remove the receiver.
3. Unplug the connector **b**.

To assemble the new receiver, carry out the above steps in reverse order.

7.5. DISASSEMBLING THE SENSORS



Only for 700, 700E and 700SP models.

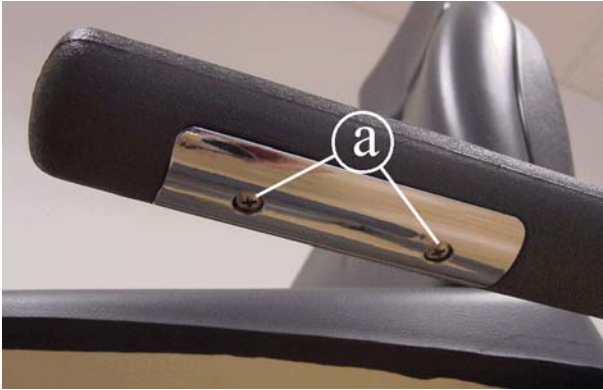

Figure 7.5-1

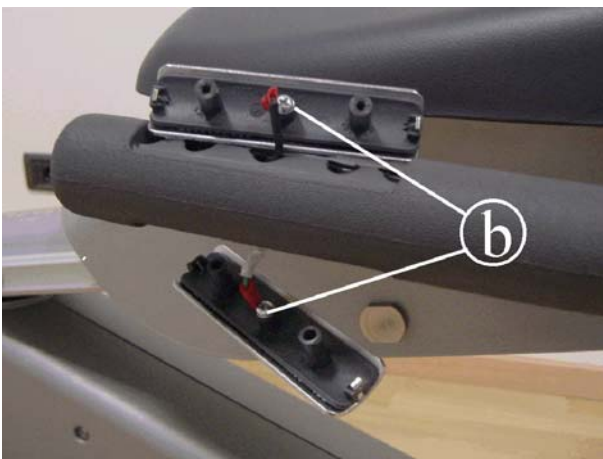

Figure 7.5-2

1. Turn off the machine and unplug the mains lead from the wall outlet (only for the 700 model).

For each sensor:

2. Back off the 2 screws **a** using a small Phillips screwdriver.
3. Lift up the top sensor.
4. Remove the lower sensor.
5. To disconnect the sensors, back off the two screws **b** using a small Phillips screwdriver.

To reassemble the sensors, carry out the above steps in reverse order.

7.6. DISASSEMBLING THE PEDALS AND THE PEDAL CRANKS



Figure 7.6-1

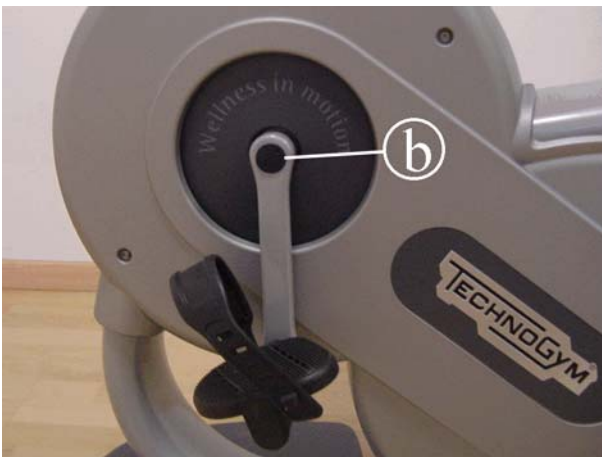

Figure 7.6-2

1. Back off the screw **a** using a 15-mm wrench and remove the pedal.

● During reassembly, lock down the screws “a” using a torque wrench set for 35 Nm.

2. Remove the plastic caps **b** from both pedal cranks.
3. Use a 14-mm socket wrench to back off the screw underneath.
4. Use a bicycle pedal extractor tool to remove the two pedal cranks.

To reassemble the pedals and the pedal cranks, carry out the above steps in reverse order.

● During reassembly, lock down the screws **b** using a torque wrench set for 40 Nm.

7.7. DISASSEMBLING THE GUARDS



Figure 7.7-1

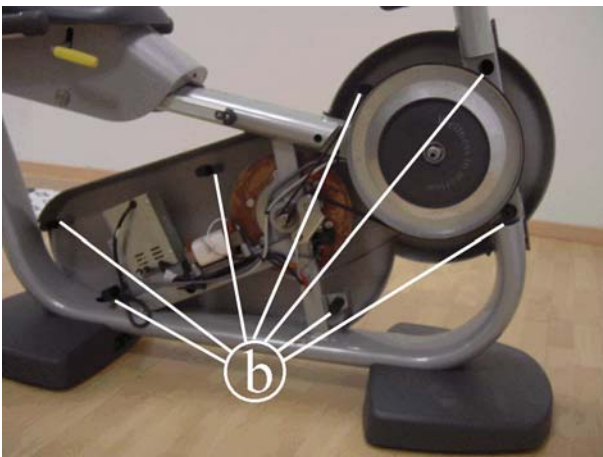

Figure 7.7-2

Carry out the procedure described in paragraph 7.6. “Disassembling the pedals and the pedal cranks”.

1. Back off the 7 screws **a** on either side of the machine using a 4-mm Allen wrench.

2. Remove the right guard first.

3. Remove the seven pins **c** from the left guard.

4. Remove the left guard.

To reassemble the guards, carry out the above steps in reverse order.

 **During reassembly, lock down the screws using a torque wrench set for 0.8 Nm.**

7.8. DISASSEMBLING THE ELECTRICAL BOX

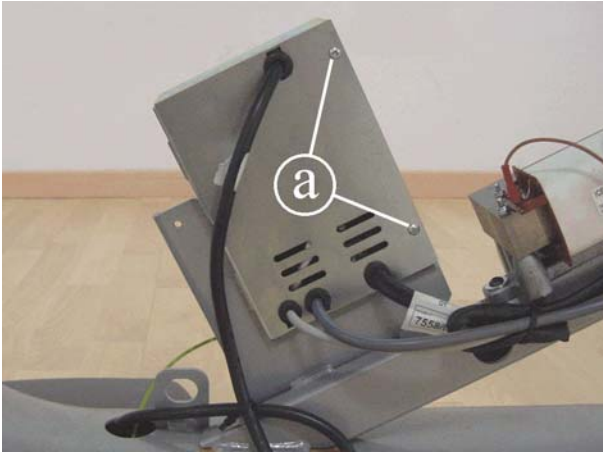

Figure 7.8-1



Figure 7.8-2

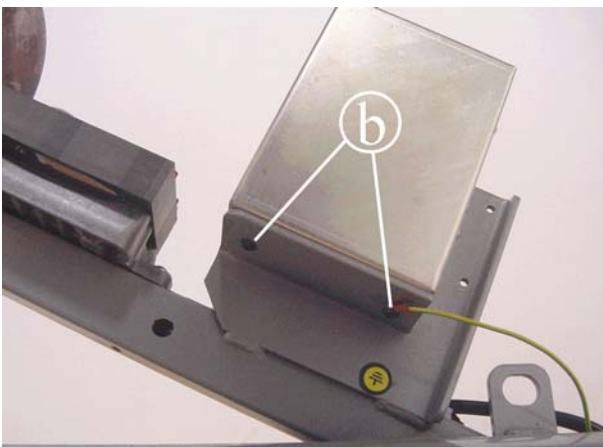

Figure 7.8-1

Carry out the procedure described in paragraph 7.7. “Disassembling the guards”.

1. Back off the screws **a** using a medium Phillips screwdriver.
2. Remove the cover from the box.

3. Unplug the connectors indicated in the figure.

4. Back off the two screws **b** using a 3-mm Allen wrench.
5. Remove the electrical box.

To reassemble the electrical box, carry out the above steps in reverse order.

- During reassembly, lock down the screws **b** using a torque wrench set for 5 Nm.**

7.9. DISASSEMBLING THE BELT

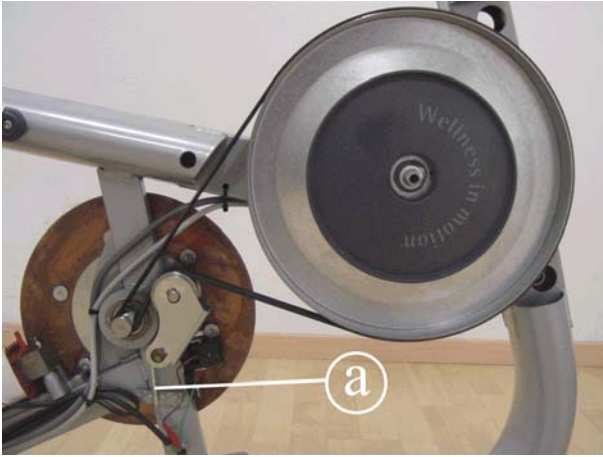

Figure 7.9-1

Carry out the procedure described in paragraph 7.7. “Disassembling the guards”.

1. Release the spring **a** of the belt tensioning mechanism.
2. Remove the belt from the pulley.

To reassemble the belt, follow the disassembly instructions in reverse order.



After completing this operation, adjust the belt tension as described in paragraph 8.1. “Belt tension”.

7.10. DISASSEMBLING THE PULLEY

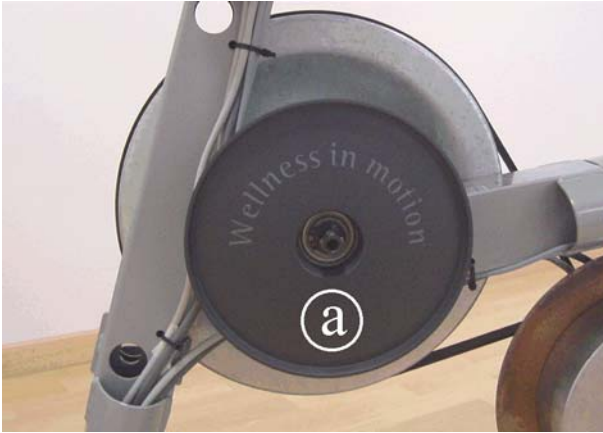

Figure 7.10-1

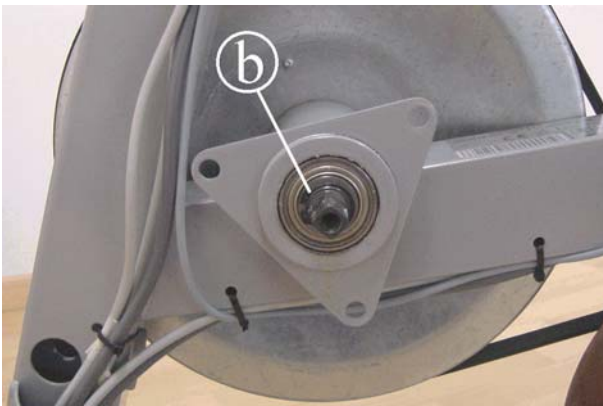

Figure 7.10-2

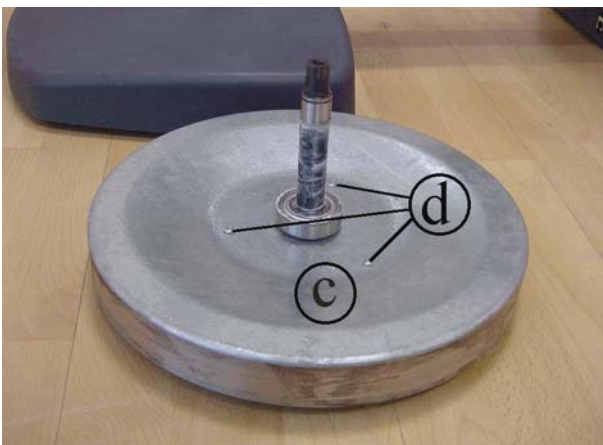



Figure 7.10-3

Carry out the operations described in paragraphs 7.7. “Disassembling the guards” and 7.9. “Disassembling the belt”.

1. On the left side of the machine, remove the plastic cover **a**.

2. Remove the snap ring **b**.

 **Be careful with the various spacer rings on the pulley shaft.**

3. Remove the pulley **c** from the opposite side of the machine.
4. Back off the 3 screws **d** using a medium Phillips screwdriver.
5. Remove the plastic cover, not visible in the photo, from the pulley **c**.

To reassemble the pulley, carry out the above steps in reverse order.

7.11. DISASSEMBLING THE BRAKE WINDING

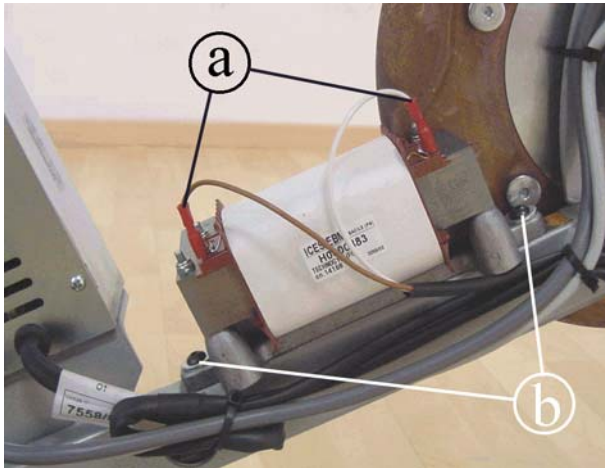

Figure 7.11-1

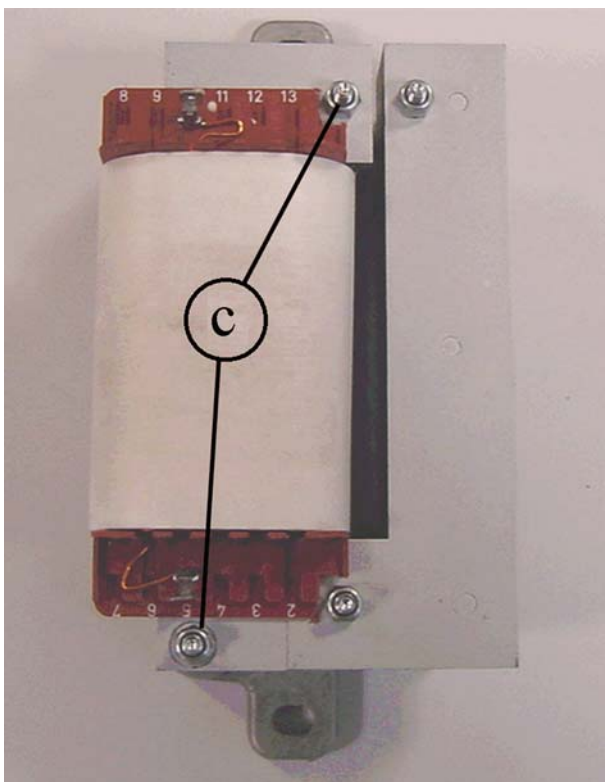

Figure 7.11-2

Carry out the operations described in paragraph 7.7. “Disassembling the guards”.

1. Unplug the two Faston connectors **a** from the winding.
2. Back off the fixing screws **b** on the machine frame, using a 3-mm Allen wrench.
3. Place the winding assembly on a work bench.
4. Back off the two nuts **c** using a 7-mm wrench, locking down the 2 through-screws from the opposite side using a 3-mm Allen wrench.
5. Remove the assembly with the winding.

To reassemble the brake winding, carry out the above steps in reverse order.

- Be careful to position the brake assembly so that the copper disk does not brush against the laminated core, using a 0.6-mm spacer.**

7.12. DISASSEMBLING THE BRAKE GROUP



Figure 7.12-1

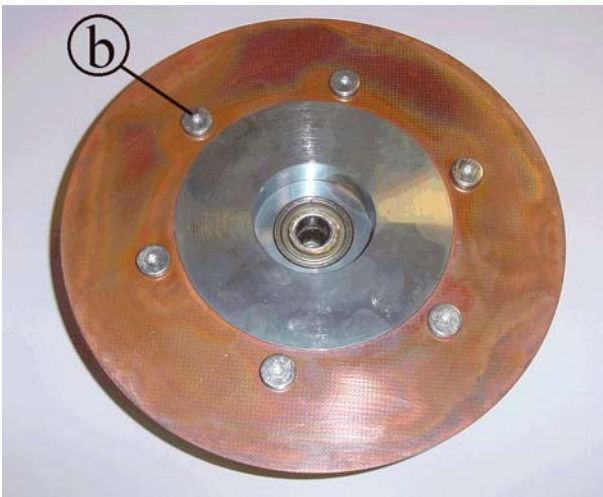

Figure 7.12-2

Carry out the operations described in paragraphs 7.7. “Disassembling the guards”, 7.9. “Disassembling the belt” and 7.11. “Disassembling the brake winding”.

1. Remove the snap ring **a** on the left side of the machine.

■ **Be careful with the various spacer rings on the pulley shaft.**

2. Remove the brake assembly
3. Place the brake assembly on a work bench.

■ **Take particular care with the copper disk, as it bends easily and may then cause problems after reassembly, by brushing against the winding block.**

4. Back off the screws **b** using a 25-mm Torx wrench.
5. Remove the copper disk.

Continued on following page →

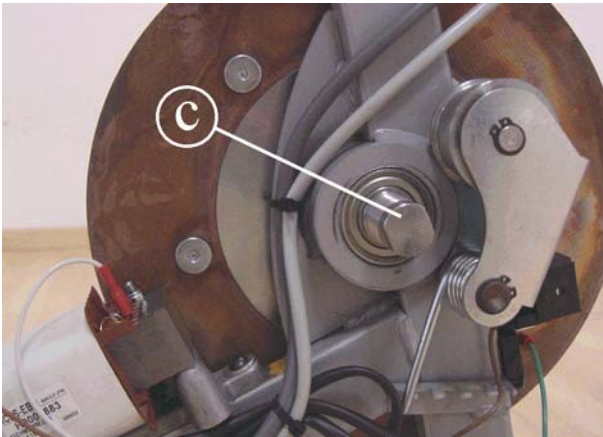

Figure 7.12-3

Disassembling the brake pulley c:

6. Unscrew the brake pulley **c** using a 17-mm wrench, using a 6-mm Allen wrench to hold the shaft in place on the opposite side.

To reassemble the brake, carry out the above steps in reverse order.

- **Remember to fully lock down all the screws **b** (in a cross pattern), as they may knock against the speed sensor if left loose. Lock down the screws using a torque wrench set for 6 Nm**
- **After reassembling the brake, use a comparator to check for any curvature of the copper disk, with a margin of ± 0.15 mm.**
- **Lock down the screw **c** using a torque wrench set for 40 Nm.**

7.13. DISASSEMBLING THE SPEED SENSOR

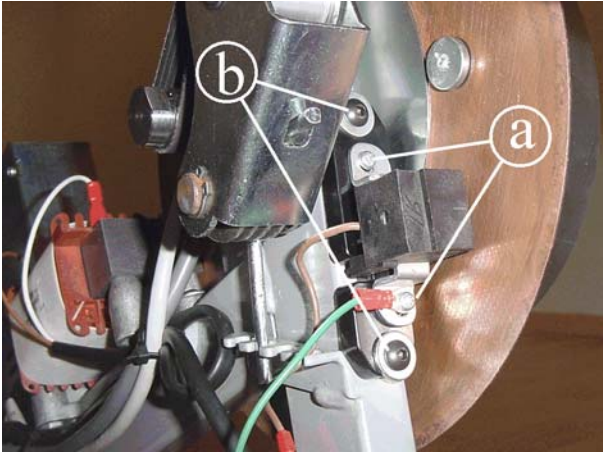

Figure 7.13-1

Carry out the operations described in paragraph 7.7. “Disassembling the guards”.

1. Back off the 2 screws **a** using a small Phillips screwdriver.
2. Remove the speed sensor.
3. If it proves difficult to back off the screws **a** in their current position, back off the screws **b** using a 3-mm Allen wrench and remove the sensor together with the support.

● **If the plastic sensor support is also removed, adjust the sensor position as described in paragraph 8.2. “Speed sensor position”.**

To reassemble the speed sensor, carry out the above steps in reverse order.

7.14. DISASSEMBLING THE PLATFORMS WITH CSAFEB BOARD CONNECTORS AND POWER ENTRY MODULE



Figure 7.14-1

The front and rear platforms house the following components:

- connector of the cable leading to the CSafe board (front platform, on the right in the figure);
- Power entry module (500, 700 e 700E) or battery charger socket (500SP e 700SP) (rear platform, on the left in the figure).

1. To access the connectors, turn the machine over on one side.
2. Back off the screws **a** of the platform which houses the desired connector, using a medium Phillips screwdriver.

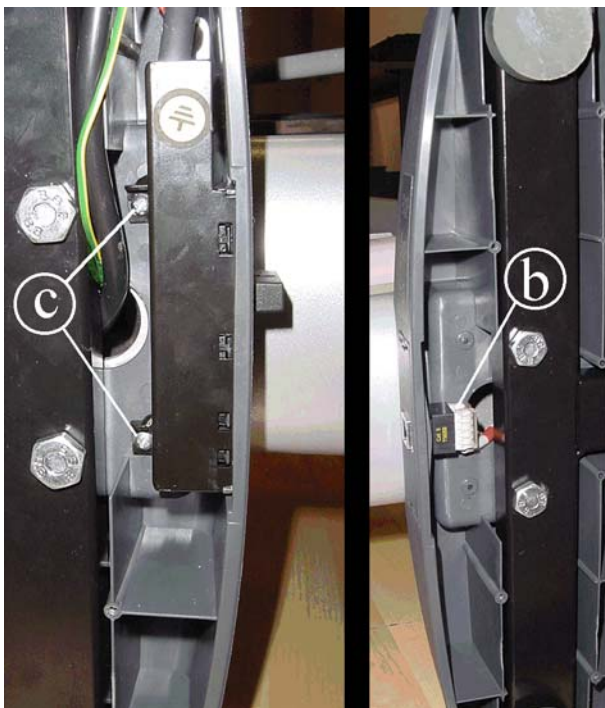

Figure 7.14-2

At this point it is possible to:

3. Unplug connector **b** of the cable which goes up to the CSafe board.
4. Back off the two screws **c** and remove the Power entry module.

Continued on following page →

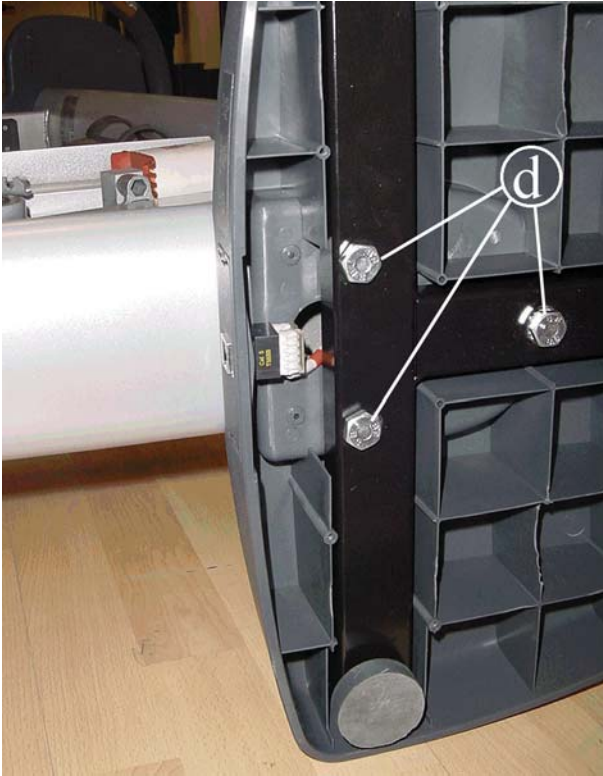

Figure 7.14-3

Disassembling the platforms (this procedure applies for both platforms):

5. To disassemble the platforms, back off the 3 screws **d** using a 17-mm wrench.

To reassemble the platforms and connectors, carry out the above steps in reverse order.

- **During reassembly, lock down the screws **b** using a torque wrench set for 44 Nm.**

7.15. DISASSEMBLING THE ALTERNATOR

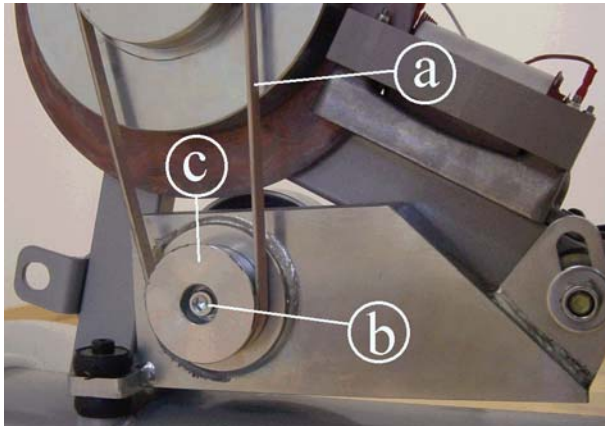

Figure 7.15-1

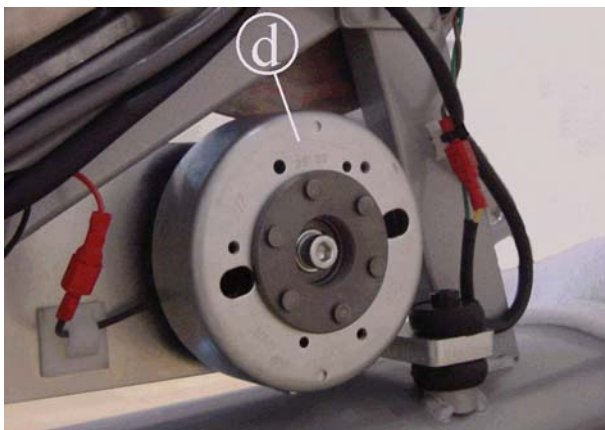

Figure 7.15-2

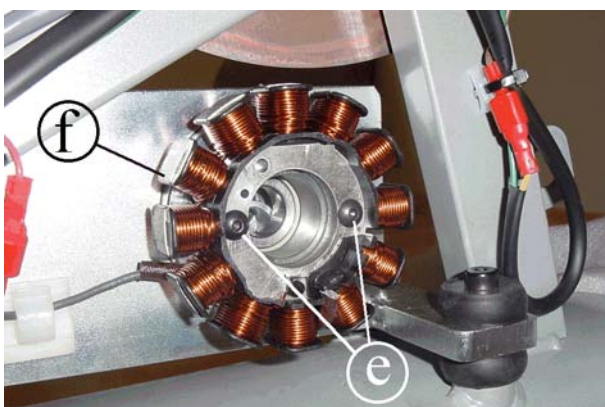

Figure 7.15-3

Carry out the operations described in paragraph 7.7. “Disassembling the guards”.

1. Remove the belt **a**.
2. Back off the screw **b** using a 6-mm Allen wrench, clamping the screw from the opposite side to prevent it rotating.
3. Remove the pulley **c**.

4. Remove the rotor **d**, pulling it outward.

5. Back off the two screws **e** using a 3-mm Allen wrench.
6. Remove the stator **f**.

To reassemble the alternator, follow the above steps in reverse order.

 Lock down the screw **c** using a torque wrench set for 22 Nm.

 The correct belt tension is between 9.9 – 12.1 lbs (4.5 – 5.5 kg).

7.16. DISASSEMBLING THE BATTERY

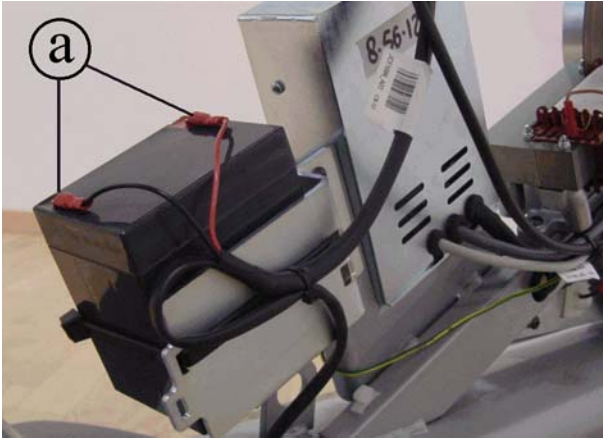

Figure 7.16-1

Carry out the operations described in paragraph 7.7. “Disassembling the guards”.

1. Unplug the Faston connectors **a** and remove the battery.

To reassemble the battery, carry out the above steps in reverse order.

7.17. DISASSEMBLING THE SADDLE

● Only 500 and 500SP models



Figure 7.17-1

1. On both side, disassemble the 2 pulleys on which the saddle moves, backing off the nut **a** using a 17-mm wrench and locking down the eccentric pin **b** using a 24-mm wrench.
2. Remove the saddle from the equipment.

To reassemble the saddle, carry out the above steps in reverse order.

● After completing this operation, adjust the saddle position as described in paragraph 8.4. “Saddle sliding”.

Only 700, 700E and 700SP models



Figure 7.17-2



Figure 7.17-3

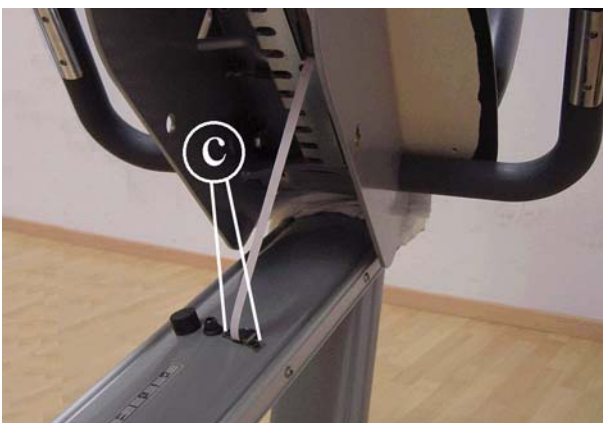

Figure 7.17-4

1. Move the saddle into position 8.
2. Protect the equipment frame using a cloth as shown in the figure.
3. On both side, disassemble the 2 pulleys on which the saddle moves, backing off the nut **a** using a 17-mm wrench and locking down the eccentric pin **b** using a 24-mm wrench.
4. Turn the saddle over its back as shown in the figure.
5. Pay attention that the saddle stays over the cloth and that the hand sensor interface board cable is not too tight.
7. Back off the two fixing screws **c** of the cable holder, using a 2.5-mm Allen wrench.

During reassembly, lock down the screws **c using a torque wrench set for 3 Nm.**

Continued on following page →



Figure 7.17-5

6. Extract the cable up to find the patch connector as shown in the figure.
7. Unplug the connector and remove the saddle.

To reassemble the saddle, carry out the above steps in reverse order.

■ After completing this operation, adjust the saddle position as described in paragraph 8.4. “Saddle sliding”.

7.18. DISASSEMBLING THE HAND SENSOR BOARD



Only for 700, 700E and 700SP models.

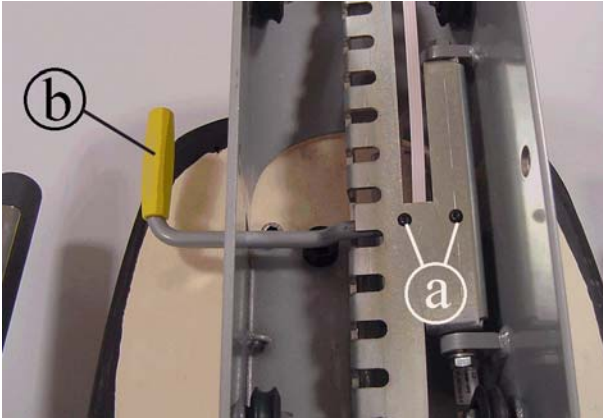

Figure 7.18-1

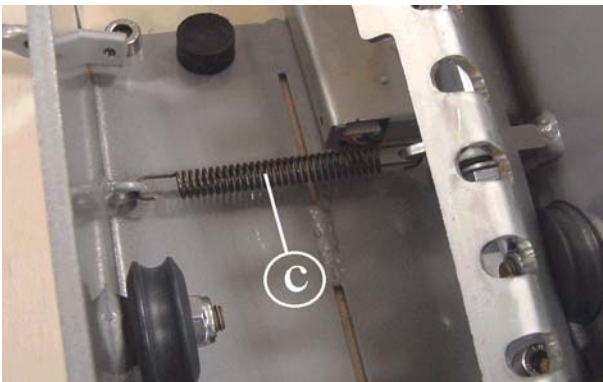

Figure 7.18-2

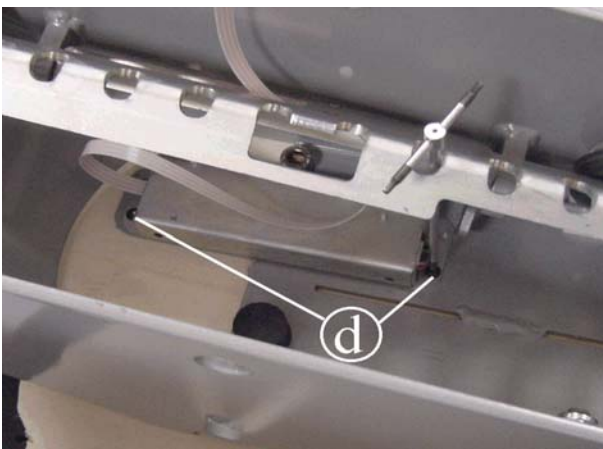

Figure 7.18-3

Carry out the operations described in paragraph 7.17. “Disassembling the saddle”.

1. Place the saddle assembly on a work bench.
2. Back off the two screws **a** using a 3-mm Allen wrench.
3. Remove the lever **b**.
4. Release the spring **c**.
5. Back off the two screws **d** that are fixing the board support to the frame, using a 2.5-mm Allen wrench.

Continued on following page →

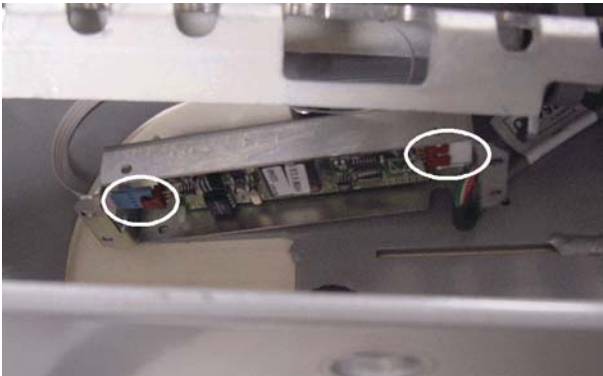

Figure 7.18-4

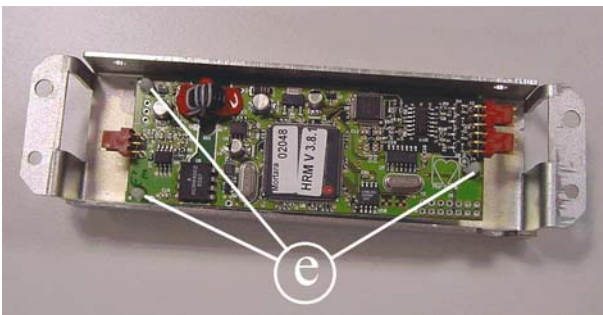

Figure 7.18-5

6. Unplug the two connectors indicated in the figure, from the board.
7. Remove the hand sensor box from the saddle frame.

8. In order to remove the board from the box, release the 3 clips **e**.

To reassemble the hand sensor board, carry out the above steps in reverse order.

7.19. DISASSEMBLING THE SADDLE HANDLEBARS

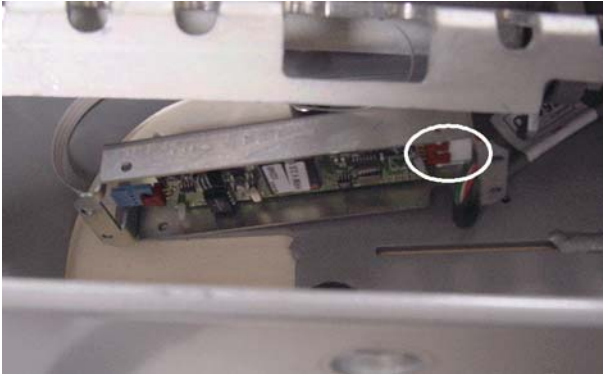

Figure 7.19-1

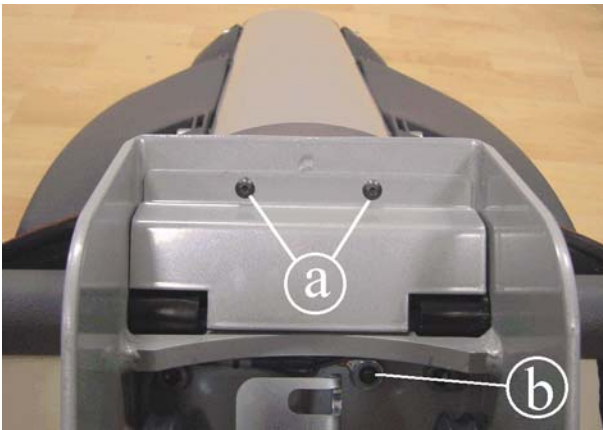

Figure 7.19-2

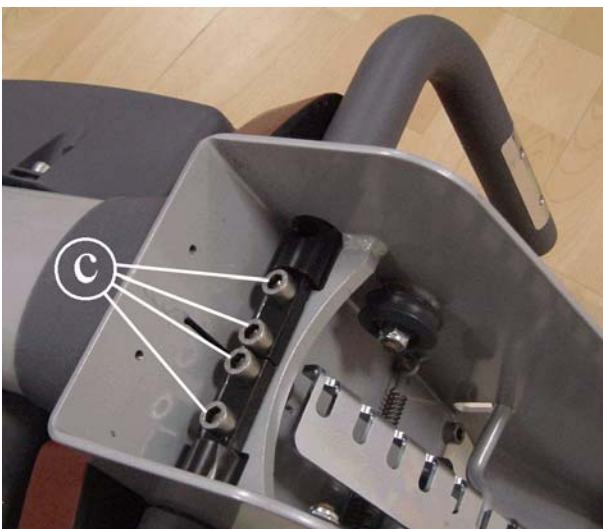

Figure 7.19-3

Carry out the operations described in paragraph 7.18. “Disassembling the hand sensor board”.

1. Unplug the connector indicated in the figure, from the board (only for the 700, 700E and 700SP models).
2. Back off the two screws **a** using a 3-mm Allen wrench and remove the covering plate.
3. Back off the screw **b** using a medium Phillips screwdriver and unplug the ground cable.
4. Back off the bolts **c** using an 8-mm Allen wrench (two bolts for each handlebar).
5. Remove the handlebars taking care not to damage the cables.

To reassemble the saddle handlebars, carry out the above steps in reverse order.

- During reassembly, lock down the screws **c** using a torque wrench set for 70 Nm.**

8. ADJUSTMENTS

8.1. BELT TENSION

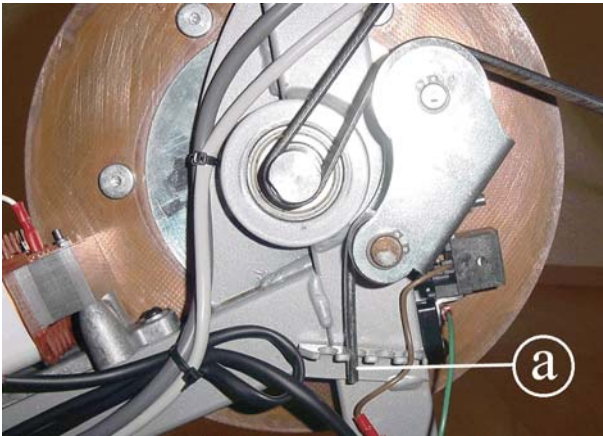



Figure 8.1-1

Carry out the operations described in paragraph 7.7. “Disassembling the guards”.

1. To adjust the tension of the belt, simply select one of the various positions available for the spring **a**.

 The correct belt tension is between **80-100 Hz** on a powered machine and between **140-180 Hz** on a self powered machine.

8.2. SPEED SENSOR POSITION

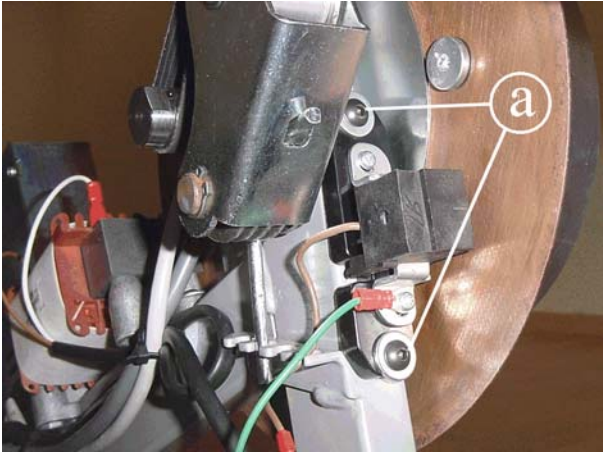

Figure 8.2-1

Carry out the operations described in paragraph 7.7. “Disassembling the guards”.

1. Back off the 2 screws **a** and shift the speed sensor support to the side, so that it is **0.7 mm** from the screws on the copper disk.
2. Lock the screws back down.

8.3. BRAKE ASSEMBLY

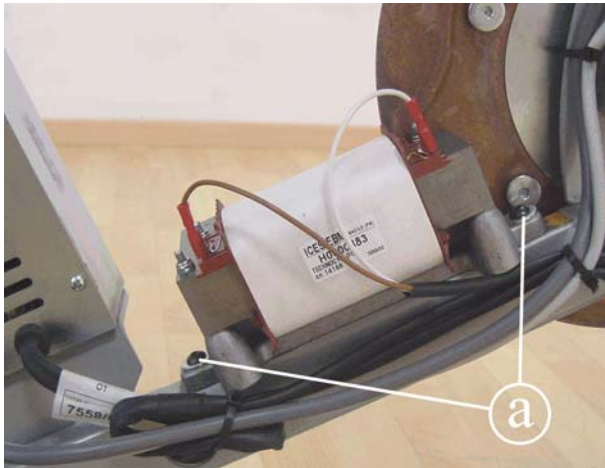

Figure 8.3-1

Carry out the operations described in paragraph 7.7. “Disassembling the guards”.

1. Back off the 2 screws **a** and shift the brake winding support to the side, so that it is **0.6 mm** from the disk.
2. Lock the screws back down.



WARNING: check the flatness of the copper disk using a comparator gauge: the permissible margin is ± 0.15 mm.

8.4. SADDLE SLIDING



Figure 8.4-1

1. Loosen the nut **a** using a 17-mm wrench.
2. Turn the eccentric pin **b** using a 24-mm wrench in such a way that the saddle moves smoothly and does not have any play vertically.
3. Lock the nut back down.

9. MACHINE CONFIGURATION

9.1. USER MENU CONFIGURATION FOR 700 MODELS

The machine configuration procedure is invoked, when the machine is in standby mode, by simultaneously pressing the keys **369**. The following prompt appears on the LED display:

ENTER PASSWORD:

To access the procedure, type in the password **2406** and press **ENTER** to confirm. At this point the machine display begins showing the current configuration, structured as in the diagram below:

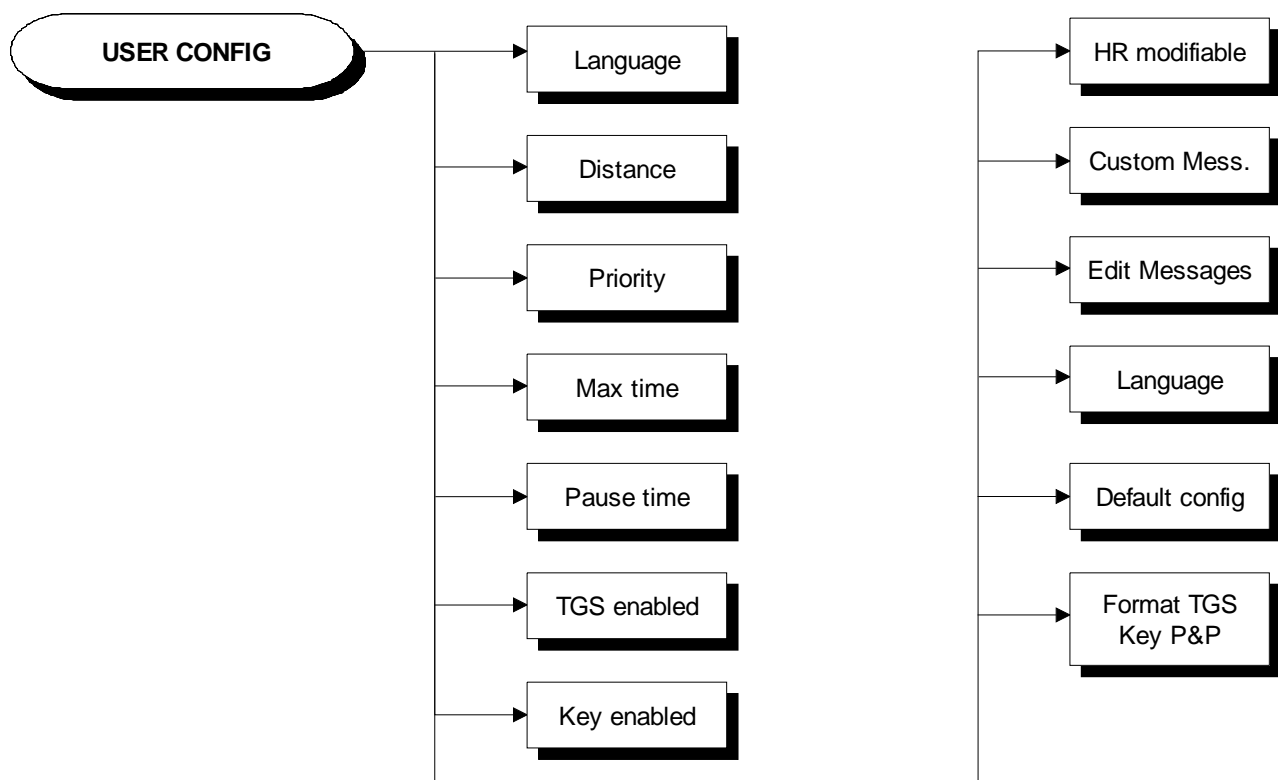

9.1.1. LANGUAGE

After selecting a language from the list of those available, all messages subsequently displayed by the machine will be in the chosen language. To change the selection, when the LED matrix shows the current setting:

LANGUAGE : xxx

Press the +/- **GOAL** keys to select the desired language from the options available. Press **ENTER** to confirm the choice, use the + or – effort level keys to move to the next or previous parameter.

9.1.2. DISTANCE

It is possible to choose between EUROPEAN units (kg and km) or IMPERIAL units (pounds and miles). To change the selection, when the LED matrix shows the current setting:

DISTANCE : xxx

Press the +/- **GOAL** keys to select the desired unit of measurement from the options listed in the table below:

DISTANCE	
KM	<default>
MLS	

Press **ENTER** to confirm the operation, use the + or – effort level keys to move to the next or preceding parameter.

9.1.3. PRIORITY SETTING

If signals are available from both the chest band and hand sensors, this parameter determines which is the preferential source for displaying the heart rate value. Obviously, if only one of these two signals is available, it will be used even if not configured as the preferential heart rate source. To change the selection, when the LED matrix shows the current setting:

PRIORITY : xxx

Press the +/- **GOAL** keys to select the preferential source from those listed in the table below:

PRIORITY	
BAND	<default>
HANDS	

Press **ENTER** to confirm the operation, use the + or – effort level keys to move to the next or preceding parameter.

9.1.4. MAXIMUM EXERCISE TIME

It is possible to set a maximum duration for the exercise in minutes, with a value ranging from 1 to 9999. To change the setting, when the LED matrix shows the current maximum exercise time:

MAX TIME: xxx

Press the **ENTER** key to modify the value: when the current parameter value starts to blink, press the **CLEAR** key to erase the current value and then use the number keys to enter the desired new value.

Press **ENTER** to confirm the operation, use the + or – effort level keys to move to the next or preceding parameter.

The default value of this parameter is 9999.



9.1.5. PAUSE TIME

It is possible to set a maximum pause time for each exercise in seconds, with values ranging from 10 to 999. To change the setting, when the LED matrix shows the current maximum time:

PAUSE TIME : xxx

Press the **ENTER** key to modify the value: when the current parameter value starts to blink, press the **CLEAR** key to erase the current value and then use the number keys to enter the desired new value.

Press **ENTER** to confirm the operation, use the + or – effort level keys to move to the next or preceding parameter.

The default value of this parameter is 60.

9.1.6. ENABLE TGS

It is possible to enable or disable the use of the TGS reader. To change the selection, when the LED matrix shows the current setting:

TGS : xxx

Press the +/- **GOAL** keys to select the desired option out of those listed in the table below:

TGS	
ENABLED	<default>
DISABLED	

Press **ENTER** to confirm the operation, use the + or – effort level keys to move to the next or preceding parameter.

9.1.7. ENABLE KEYBOARD

It is possible to disable the keyboard so that the machine can only be used with the TGS. To change the selection, when the LED matrix shows the current setting:

KEYS : xxx

Press the +/- **GOAL** keys to select the desired option out of those listed in the table below:

KEYS	
ENABLED	<default>
DISABLED	

Press **ENTER** to confirm the operation, use the + or – effort level keys to move to the next or preceding parameter.

9.1.8. MODIFIABLE TARGET HEART RATE

It is possible to enable or disable modification of the target heart rate during a constant heart rate exercise. To change the selection, when the LED matrix shows the current setting:

HR : xxx

Press the +/- **GOAL** number keys to select the desired option out of those listed in the table below:

HR
MODIFIABLE <default>
NOT MODIFIABLE

Press **ENTER** to confirm the operation, use the + or – effort level keys to move to the next or preceding parameter.

9.1.9. ENABLE CUSTOM MESSAGES

It is possible to configure whether a custom message is displayed when the machine is in the standby state. To change the selection, when the LED matrix shows the current setting:

CUSTOM MESS. : xxx

Press the +/- **GOAL** number keys to select the desired option out of those listed in the table below:

CUSTOM MESS.
YES <default>
NO

Press **ENTER** to confirm the operation, use the + or – effort level keys to move to the next or preceding parameter.

9.1.10. EDIT CUSTOM MESSAGES

It is possible to modify the custom messages; press **ENTER** to invoke a submenu which displays the first custom message, then use the +/- effort level keys to move to the other messages. Press the **ENTER** key again to begin editing a message, or hold down the **CLEAR** key for a few seconds to return to the upper menu level. While editing a message, move the cursor using +/- **GOAL**, select the desired letter using the +/- effort level keys and use **CLEAR** to enter a blank space character.

Press **ENTER** to save the modified message, or hold down the **CLEAR** key to cancel and return to the upper menu level.

9.1.11. ENABLE MULTI-LANGUAGE MODE

The machine can be configured to allow selection of the language at each session. To change the selection, when the LED matrix shows the current setting:

LANGUAGE : xxx

Press the +/- **GOAL** number keys to select the desired option out of those listed in the table below:



LANGUAGE	
FIXED	<default>
OPTIONAL	

Press **ENTER** to confirm the operation, use the + or – effort level keys to move to the next or preceding parameter.

9.1.12. RESETTING PARAMETERS TO DEFAULT VALUES

It is possible to reset the user menu parameters to their default values. To select the function, when the LED matrix shows:

DEFAULT CONFIG.

Press **ENTER** to confirm the operation, use the + or – effort level keys to move to the next or preceding parameter. If the **ENTER** key is pressed the LED matrix will show:

CONFIRM ?

press **ENTER** to confirm, or cancel by pressing the **CLEAR** key for a few seconds.

9.1.13. FORMAT P&P

This function formats a TGS key for Plug&Play mode operation. To select the function, when the LED matrix shows:

FORMAT P&P

press **ENTER** to confirm, or cancel by pressing the **CLEAR** key for a few seconds.

At the end of the configuration procedure, hold down the **CLEAR** key for a few seconds to exit. The **CLEAR** key can be pressed at any time to interrupt the procedure and revert to standby mode.

9.2. USER MENU CONFIGURATION FOR 500 MODEL

The machine configuration procedure is invoked, when the machine is in standby mode, by simultaneously pressing the keys **ENTER**, **↑**, **CLEAR**. The following prompt appears on the LED display:

ENTER PASSWORD:

To access the procedure, insert the password **2406** and press **ENTER** to confirm. To enter the password without the numeric keypad, enter one digit at a time using the **↑** and **↓** keys to change the value and the **+/- GOAL** keys to scroll to the next character.

At this point the machine display begins showing the current configuration, structured as in the diagram below:

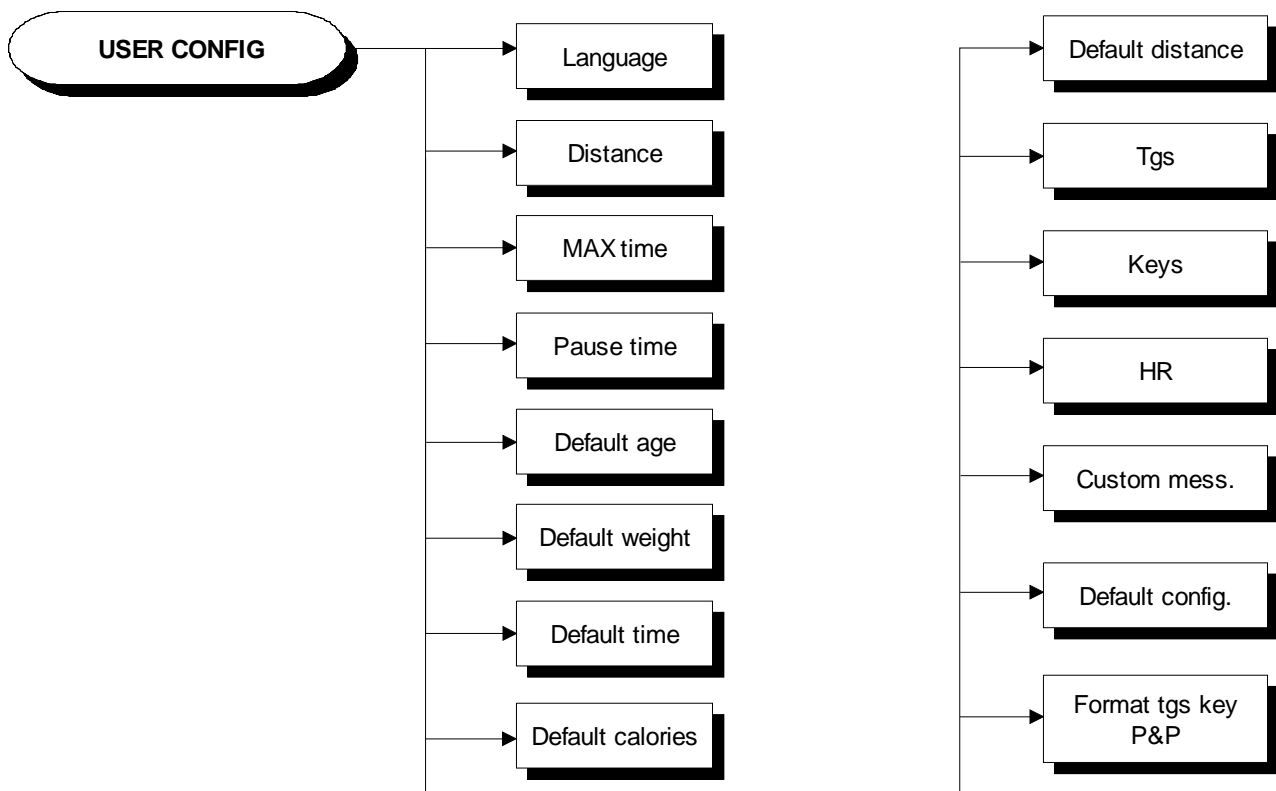

9.2.1. LANGUAGE

After selecting a language from the list of those available, all messages subsequently displayed by the machine will be in the chosen language. To change the selection, when the LED matrix shows the current setting:

LANGUAGE : xxx

Press the **+/- GOAL** keys to select the desired language from the options available. Press **ENTER** to confirm the choice, use the **+** or **-** effort level keys to move to the next or previous parameter.



9.2.2. DISTANCE

It is possible to choose between EUROPEAN units (kg and km) or IMPERIAL units (pounds and miles). To change the selection, when the LED matrix shows the current setting:

DISTANCE : xxx

Press the +/- **GOAL** keys to select the desired unit of measurement from the options listed in the table below:

DISTANCE	
KM	<default>
MLS	

Press **ENTER** to confirm the operation, use the + or – effort level keys to move to the next or preceding parameter.

9.2.3. MAXIMUM EXERCISE TIME

It is possible to set a maximum duration for the exercise in minutes, with a value ranging from 1 to 9999. To change the setting, when the LED matrix shows the current maximum exercise time:

MAX TIME: xxx

Press the **ENTER** key to modify the value: when the current parameter value starts to blink, press the **CLEAR** key to erase the current value and then enter one digit at a time using the ↑ and ↓ keys to change the value and the +/- **GOAL** keys to scroll to the next character.

Press **ENTER** to confirm the operation, use the + or – effort level keys to move to the next or preceding parameter.

The default value of this parameter is 9999.

9.2.4. PAUSE TIME

It is possible to set a maximum pause time for each exercise in seconds, with values ranging from 10 to 999. To change the setting, when the LED matrix shows the current maximum time:

PAUSE TIME : xxx

Press the **ENTER** key to modify the value: when the current parameter value starts to blink, press the **CLEAR** key to erase the current value and then enter one digit at a time using the ↑ and ↓ keys to change the value and the +/- **GOAL** keys to scroll to the next character.

Press **ENTER** to confirm the operation, use the + or – effort level keys to move to the next or preceding parameter.

The default value of this parameter is 60.

9.2.5. DEFAULT AGE

It is possible to set the default age for a generic user, with values ranging from 10 to 99. To change the setting, when the LED matrix shows the current setting:

DEFAULT AGE : xx

Press the **ENTER** key to change the parameter: the current value of the parameter will start to blink, press the **CLEAR** key to erase the current value and then enter one digit at a time using the **↑** and **↓** keys to change the value and the **+/- GOAL** keys to scroll to the next character.

Press **ENTER** to confirm the changes made, and use the **+** or **-** effort level keys to move to the next or preceding parameter.

The default value of this parameter is 30.

9.2.6. DEFAULT WEIGHT

It is possible to set the default weight of a generic user in KG, with values ranging from 10 to 999. To change the setting, when the LED matrix shows the current setting:

DEFAULT WEIGHT : KG xxx

Press the **ENTER** key to change the parameter: the current value of the parameter will start to blink, press the **CLEAR** key to erase the current value and then enter one digit at a time using the **↑** and **↓** keys to change the value and the **+/- GOAL** keys to scroll to the next character.

Press **ENTER** to confirm the changes made, and use the **+** or **-** effort level keys to move to the next or preceding parameter.

The default value of this parameter is KG 70.

9.2.7. DEFAULT TIME

It is possible to set the default duration of the exercise in minutes, with values ranging from 10 to 999. To change the setting, when the LED matrix shows the current time:

DEFAULT TIME : MIN. xxx

Press the **ENTER** key to change the parameter: the current value of the parameter will start to blink, press the **CLEAR** key to erase the current value and then enter one digit at a time using the **↑** and **↓** keys to change the value and the **+/- GOAL** keys to scroll to the next character.

Press **ENTER** to confirm the changes made, and use the **+** or **-** effort level keys to move to the next or preceding parameter.

The default value of this parameter is 15.



9.2.8. DEFAULT CALORIES

It is possible to set the calories for every exercise, with values ranging from 10 to 999. To change the setting, when the LED matrix shows the current setting:

DEFAULT CALORIES : xxx

Press the **ENTER** key to change the parameter: the current value of the parameter will start to blink, press the **CLEAR** key to erase the current value and then enter one digit at a time using the **↑** and **↓** keys to change the value and the **+/- GOAL** keys to scroll to the next character.

Press **ENTER** to confirm the changes made, and use the **+** or **-** effort level keys to move to the next or preceding parameter.

The default value of this parameter is 300.

9.2.9. DEFAULT DISTANCE

It is possible to set the distance for every exercise in Km, with values ranging from 1 to 999. To change the setting, when the LED matrix shows the current setting:

DEFAULT DISTANCE : KM xxx

Press the **ENTER** key to change the parameter: the current value of the parameter will start to blink, press the **CLEAR** key to erase the current value and then enter one digit at a time using the **↑** and **↓** keys to change the value and the **+/- GOAL** keys to scroll to the next character.

Press **ENTER** to confirm the changes made, and use the **+** or **-** effort level keys to move to the next or preceding parameter.

The default value of this parameter is 10.

9.2.10. ENABLE TGS

It is possible to enable or disable the use of the TGS reader. To change the selection, when the LED matrix shows the current setting:

TGS : xxx

Press the **+/- GOAL** keys to select the desired option out of those listed in the table below:

TGS	
ENABLED	<default>
DISABLED	

Press **ENTER** to confirm the operation, use the **+** or **-** effort level keys to move to the next or preceding parameter.

9.2.11. ENABLE KEYBOARD

It is possible to disable the keyboard so that the machine can only be used with the TGS. To change the selection, when the LED matrix shows the current setting:

KEYS : xxx

Press the +/- **GOAL** keys to select the desired option out of those listed in the table below:

KEYS
ENABLED <default>
DISABLED

Press **ENTER** to confirm the operation, use the + or – effort level keys to move to the next or preceding parameter.

9.2.12. MODIFIABLE TARGET HEART RATE

It is possible to enable or disable modification of the target heart rate during a constant heart rate exercise. To change the selection, when the LED matrix shows the current setting:

HR : xxx

Press the +/- **GOAL** number keys to select the desired option out of those listed in the table below:

HR
MODIFIABLE <default>
NOT MODIFIABLE

Press **ENTER** to confirm the operation, use the + or – effort level keys to move to the next or preceding parameter.

9.2.13. ENABLE CUSTOM MESSAGES

It is possible to configure whether a custom message is displayed when the machine is in the standby state. To change the selection, when the LED matrix shows the current setting:

CUSTOM MESS. : xxx

Press the +/- **GOAL** number keys to select the desired option out of those listed in the table below:

CUSTOM MESS.
YES <default>
NO

Press **ENTER** to confirm the operation, use the + or – effort level keys to move to the next or preceding parameter.

9.2.14. RESETTING PARAMETERS TO DEFAULT VALUES

It is possible to reset the user menu parameters to their default values. To select the function, when the LED matrix shows:

DEFAULT CONFIG.

Press **ENTER** to confirm the operation, use the + or – effort level keys to move to the next or preceding parameter. If the **ENTER** key is pressed the LED matrix will show:

CONFIRM ?

press **ENTER** to confirm, or cancel by pressing the **CLEAR** key for a few seconds.

9.2.15. FORMAT P&P

This function formats a TGS key for Plug&Play mode operation. To select the function, when the LED matrix shows:

FORMAT P&P

press **ENTER** to confirm, or cancel by pressing the **CLEAR** key for a few seconds.

At the end of the configuration procedure, hold down the **CLEAR** key for a few seconds to exit. The **CLEAR** key can be pressed at any time to interrupt the procedure and revert to standby mode.

9.3. SERVICE MENU CONFIGURATION

The configuration procedure is invoked when the machine is in standby mode, using a different procedure for the 500 and 700 models.

- **Accessing configuration of 500 models**

Simultaneously press the **ENTER**, **↑**, **CLEAR** keys. The following prompt appears on the LED display:

ENTER PASSWORD:

To access the procedure, type in the password **2501** which protects against unauthorized access and press “Enter” to confirm. To enter the password, increase or decrease the displayed value using the **↑** and **↓** keys, or use the +/- **GOAL** keys to scroll through and modify the individual digits. At this point there are two options available:

↑ = Tech Config
↓ = Troubleshooting

Press numeric key **↑** to access the menu for configuring technical parameters; the machine display will begin showing the current configuration, structured as in the diagram below:

- **Accessing configuration of 700 models**

Simultaneously press the keys **369**. The following prompt appears on the display:

ENTER PASSWORD:

To access the procedure, type in the password **2501** which protects against unauthorized access and press the “Enter” key to confirm. At this point there are two options available:

1 = Tech Config
2 = Troubleshooting

Press numeric key **1** to access the menu for configuring technical parameters; the machine display will begin showing the current configuration, structured as in the diagram below:

• Configuration

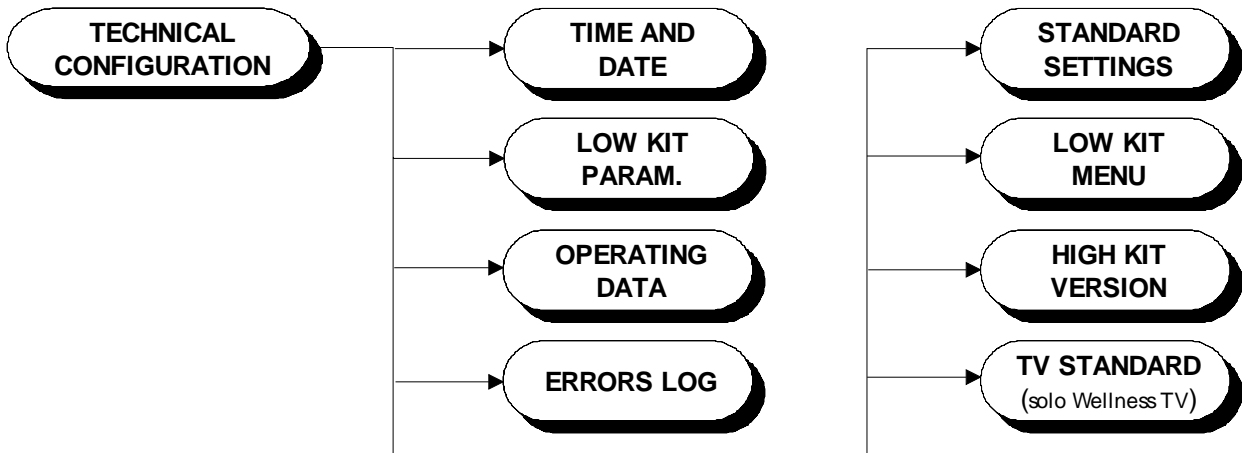

To scroll through the list of parameters, press the + or – effort level keys to display the next or the preceding item.

To modify a parameter value, it is necessary to press the **ENTER** key: when the current parameter value starts to blink, press the **CLEAR** key to erase the current value and then use the number keys to enter the desired new value. Save the changes made by pressing the **ENTER** key.

To cancel the operation, press the **CLEAR** key for a few seconds.

The various parameters are described below.

9.3.1. TIME AND DATE

This function sets the internal clock of the lower assembly. To access this menu, when the LED display shows:

TIME AND DATE

press **ENTER**. This function is structured as follows:

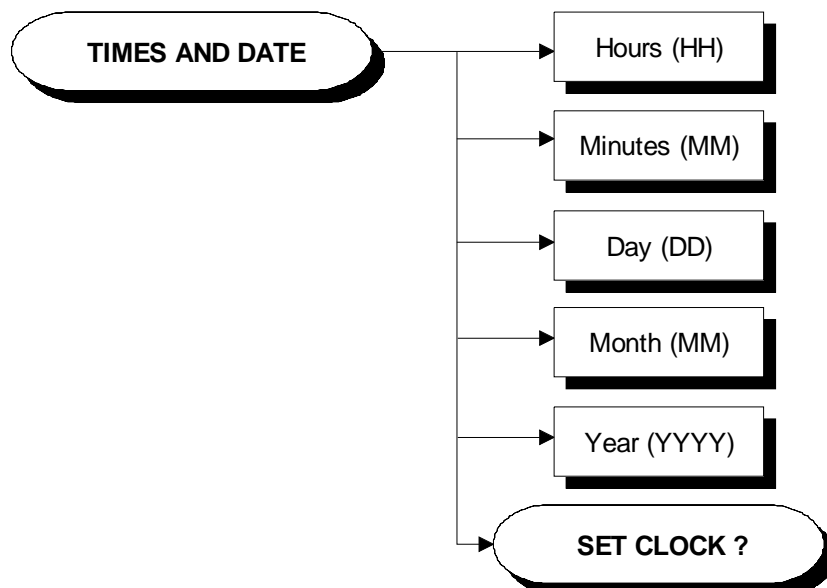

9.3.1.1. Hour

This parameter sets the hour of the internal clock.

9.3.1.2. Minutes

This parameter sets the minutes of the internal clock.

9.3.1.3. Day

This parameter sets the date of the internal clock.

9.3.1.4. Month

This parameter sets the month of the internal clock.

9.3.1.5. Year

This parameter sets the year of the internal clock.

9.3.1.6. Set Clock

This item is used for programming the internal clock chip with the values entered previously. To do this, when the LED matrix shows:

SET CLOCK

press the **ENTER** key.

9.3.2. LOW KIT PARAMETER

This function provides access to parameters used for modifying certain settings of the lower assembly, or for monitoring the state of the machine. To access this menu, when the LED display shows:

LOW KIT PARAM.

press **ENTER**. This function is structured as follows:

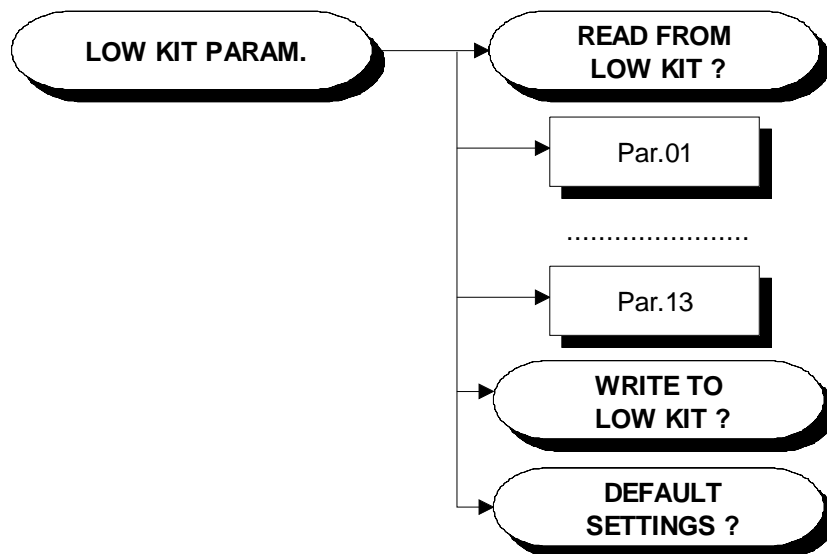

In addition to the 13 configuration parameters, this function also includes the 3 sub-functions described below:

9.3.2.1. Read from low kit

To read the parameter values from the low kit memory and view them on the display, scroll using the +/- keys until the LED display shows:

READ FROM LOW KIT ?

press **ENTER** to read the errors from the low kit, and return to the upper menu level by pressing **CLEAR** for a few seconds.

9.3.2.2. Write to low kit

To write the values of the currently displayed parameters to the low kit, scroll using the +/- keys until the LED display shows:

WRITE TO LOW KIT ?

press **ENTER** to write the parameters to the low kit, and return to the upper menu level by pressing **CLEAR** for a few seconds.

9.3.2.3. Default Setting

To load the default parameter values, scroll using the +/- effort level keys until the LED display shows:

DEFAULT SETTING ?

press **ENTER** to write the default values to the low kit, and return to the upper menu level by pressing **CLEAR** for a few seconds.



To write these parameters to the low kit, use the “Write to low kit” function.

9.3.2.4. Configuration parameters table

Display parameter	Description	Default value
Par 01	Transmission ratio	143
Par 02	Coefficient for converting SPM to speed	9
Par 03	Minimum braking current	500 (powered) 0 (self powered)
Par 04	Maximum continuous power	200
Par 05	Machine correction coefficient	100
Par 06	User friction torque	15
Par 07	Maximum coil temperature	125
Par 08	Minimum revolutions (RPM)	30
Par 09	RPM integration scale	1
Par 10	Filter threshold (RPM)	30
Par 11	-	0
Par 12	User friction torque delta	5
Par 13	-	0

9.3.3. OPERATING DATA

This function makes it possible to access the machine usage data stored in the low kit. To access this menu, when the LED display shows:

OPERATING DATA

press **ENTER**. This function is structured as follows:

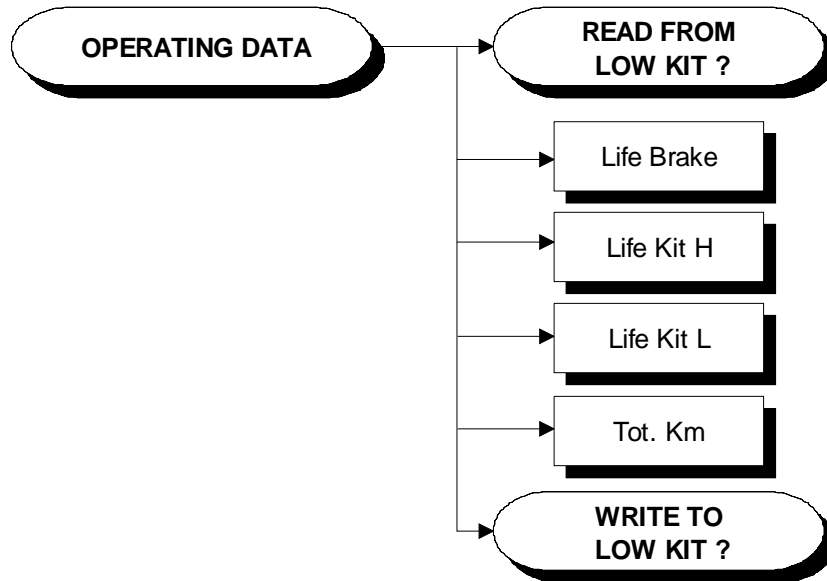

In addition to the machine usage data, this function also includes the 2 sub-functions described below:

9.3.3.1. Read from low kit

To read the parameter values from the low kit memory and view them on the display, scroll using the +/- keys until the LED display shows:

READ FROM LOW KIT ?

press **ENTER** to read the errors from the low kit, and return to the upper menu level by pressing **CLEAR** for a few seconds.

9.3.3.2. Write to low kit

To write the values of the currently displayed parameters to the low kit, scroll using the +/- keys until the LED display shows:

WRITE TO LOW KIT ?

press **ENTER** to write the new data to the low kit, and return to the upper menu level by pressing **CLEAR** for a few seconds.

9.3.3.3. Machine usage data

The machine usage data on the display is updated every 10 minutes. This means that, whenever the machine is switched off, any data modified after the last memory update will be lost.

MESSAGE ON DISPLAY	DESCRIPTION
Life Brake:	Minutes x 10 of operation of the brake
Life Kit H:	Minutes x 10 of operation of the upper assembly
Life Kit L:	Minutes x 10 of operation of the lower assembly
Tot. Km:	Total km traveled

By selecting one of the items in the above table it is possible to modify its content, but only after having cleared its value. When the **ENTER** key is pressed the message "Reset life..." appears, followed by the name of the selected item; pressing **ENTER** again resets the value of the selected item, while pressing **CLEAR** reverts to the preceding value.

9.3.4. ERRORS LOG

This function accesses the machine's error history log. To access this menu, when the LED display shows:

ERRORS LOG

press **ENTER**. This function is structured as follows:

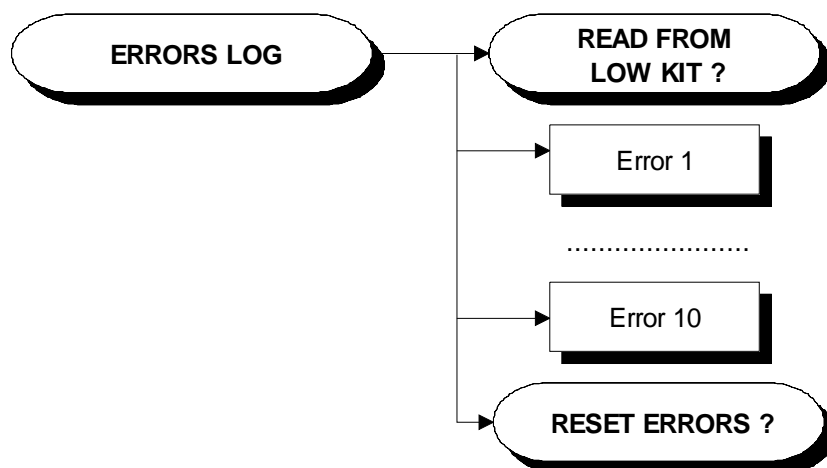

In addition to the error history log, this function also includes the 2 sub-functions described below:

9.3.4.1. Read from low kit

To read the errors stored in low kit memory and view them on the display, scroll using the +/- keys until the LED display shows:

READ FROM LOW KIT ?

press **ENTER** to read the errors from the low kit, and return to the upper menu level by pressing **CLEAR** for a few seconds.

9.3.4.2. Reset Errors

To clear the error history in both the low and high kit memory, scroll using the +/- keys until the LED display shows:

RESET ERRORS ?

press **ENTER** to clear the error history logs, and return to the upper menu level by pressing **CLEAR** for a few seconds.

9.3.4.3. View Errors

For every error generated by the machine, the error history log records the information in the table below:

- Counter
- Error code
- date (dd-mm-yyyy – hh:mm)
- Current when the error occurred
- Distance in km when the error occurred

The correspondence between error codes and descriptions is given in the table below:

Error Code	Description
1	OVERHEATING: this condition occurs when the temperature measured by the sensor on the circuit board exceeds 90°C.
2	OVERCURRENT: this condition occurs when the current going to the solenoid measured by the board exceed the max value.
4	UNDERVOLTAGE: this condition occurs when the +12 Vdc voltage drops below 9.7 Vdc (only on the 500, 700 and 700E models).
8	OVERVOLTAGE: this condition occurs when the +12 Vdc voltage goes above 13.7 Vdc (only on the 500, 700 and 700E models).
16	WATCHDOG: this condition occurs when the brake board SW crashes.
32	EPROM: SW error on the brake board.
128	MACHINE NOT CALIBRATED: this error condition occurs when the calibration parameter stored in the brake board is incorrect.

Use the + speed key to advance to the next error, otherwise the message with the details of the current error will continue to reappear.

9.3.5. STANDARD SETTINGS

This function simultaneously resets the brake interface board parameters to their default values, and clears the operating data of the machine. To access this menu, when the LED display shows:

STANDARD SETTINGS ?

press **ENTER**, the following message appears:

CONFIRM ?

Press **ENTER** again to reset all parameters to their default values, or return to the upper menu level by pressing **CLEAR** for a few seconds.



This function does not alter the language setting.

9.3.6. LOW KIT MENU

This function directly accesses the firmware of the brake board. To access this menu, when the LED display shows:

LOW KIT MENU

press **ENTER**. This function is structured as follows:

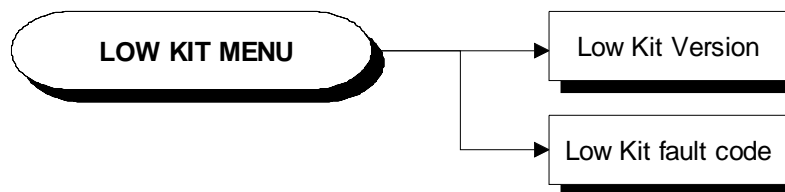

9.3.6.1. Low kit version

This function displays the brake board firmware version. To access this menu, when the LED display shows:

LOW KIT VERSION

press **ENTER**, the following message appears:

H:x L:x B:x

Which identifies the firmware version.

9.3.6.2. Low Kit fault code

This function displays the error code that is blocking the low kit. To access this menu, when the LED display shows:

LOW KIT FAULT CODE

press **ENTER**, the following message appears:

FAULT=XX



In case of FAULT=00, the board is not in an error condition.

9.3.7. HIGH KIT VERSION

This function displays the SW version of the display. To do this, when the LED display shows:

HIGH KIT VERSION

press **ENTER**, the message that identifies the SW version, will appear.

9.3.8. TV STANDARD (700E VERSION ONLY)

This function displays the TV Standard configured on the machine. To change the selection when the LED matrix shows the current setting:

TV STANDARD: XXX

Press the +/- **GOAL** keys to select the desired language from the options available. Press **ENTER** to confirm the choice, use the + or – speed keys to move to the next or previous parameter.

The alternatives are:

PAL B/G	SECAM E/L	SECAM B/G
PAL I	SECAM D/K	SECAM K1
PAL N	NTSC 44	PAL M
NTSC	PAL D/K	

Selected as a function of the country where the machine is installed according to **Table 4-1**.

9.4. TV MENU CONFIGURATION FOR 700E MODEL

9.4.1. TV CHANNEL TUNING

To access the TV channel tuning procedure, simultaneously press the **369** keys when the machine is in stand by. The following prompt appears on the LCD display:

ENTER PASSWORD:

To access the procedure, type in the password **2407** and press **ENTER** to confirm. At this point the machine display begins showing the current configuration, structured as in the diagram below:



To tune a channel, use the keypad in the figure below:



1. Select the desired channel using the < and > keys.
2. Press ENTER; the frequency shown alongside the selected channel will turn yellow.
3. Use the + and - keys to scan through the frequencies.
4. The available range of frequencies is divided into sub-bands, press the CLEAR key to skip back to the start of the preceding sub-band.
5. After finding the desired signal, press the ENTER key again.

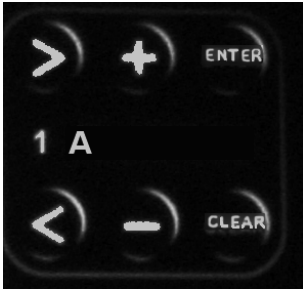

6. A yellow “A” will appear alongside the number of the channel.
7. Enter the desired name using the + and - keys to change the character and the < and > keys to scroll through the letters (4 characters max).
8. Press the ENTER key again: The name of the channel will turn blue.
9. At this point the tuning procedure is complete. Repeat the above steps for each desired channel.
10. Before exiting the tuning menu, press the “SAVE” key. Press ENTER to confirm, or cancel by pressing the CLEAR key.
11. Exit with the “ESC” key.

9.4.2. WELLNESS TV ADJUSTMENTS



The keys in the figure at left can perform certain adjustments on the Wellness TV. In particular, it is possible to:

1. Increase or reduce the brightness of the LCD.
2. Increase or reduce the contrast of the LCD.
3. Before exiting the adjustments menu, press the “SAVE” key. Press ENTER to confirm, or cancel by pressing the CLEAR key.
4. Exit with the “EXIT” key.

9.5. RADIO MENU CONFIGURATION FOR 700E MODEL

9.5.1. RADIO CHANNEL TUNING

To access the radio channel tuning procedure, simultaneously press the **369** keys when the machine is in stand by. The following prompt appears on the LCD display:

ENTER PASSWORD:

To access the procedure, type in the password **2408** and press **ENTER** to confirm. At this point the machine display begins showing the current configuration, structured as in the diagram below:



To tune a channel, use the keypad in the figure below:



1. Select the desired channel using the < and > keys.
2. Press ENTER; the frequency shown alongside the selected channel will turn yellow.
3. Use the + and - keys to scan through the frequencies.
4. Pressing the CLEAR key will skip back to the lowest frequency.
5. After finding the desired signal, press the ENTER key again.
6. Repeat the above steps for each desired channel.
7. Before exiting the tuning menu, press the "SAVE" key: Press ENTER to confirm, or cancel by pressing the CLEAR key.
8. Exit with the "ESC" key.

9.6. TRANSFERRING THE TUNING DATA

The TV and radio channel tuning data can be transferred from one machine to the other in 2 ways:

9.6.1. USING THE TGS

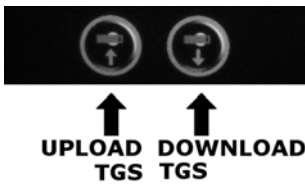

On the already tuned machine:

1. Enter the configuration menu of the channels that are to be transferred.
2. Insert the TGS key in the key reader on the machine.
3. Press the “UPLOAD TGS” button, this will cause all the channel configuration data to be saved to the key.
4. Exit the menu by pressing “ESC”.

On the machine to be tuned:

1. Enter the configuration menu of the channels that need to be tuned.
2. Insert the TGS key to which the tuning data was saved.
3. Press the “DOWNLOAD TGS” key.
4. Save the data uploaded to the machine by pressing “SAVE”.
5. Exit the menu by pressing the “ESC” key.

9.6.2. USING THE CONNECTING CABLE

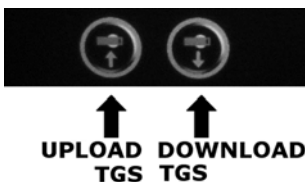

1. Connect the two machines together using the cable described in paragraph 4.4. “Cable for exchanging TV channel tuning data between two machines”.
2. On both machines, enter the configuration menu of the channels that are to be tuned.
3. Press the “UPLOAD TGS” button on the already tuned machine.
4. Store the data transferred to the machine being tuned by pressing “SAVE”.
5. Exit the menu on both machines by pressing “ESC”.

10. SCHEDULED MAINTENANCE

To keep the machine in perfect working order and forestall possible problems it is necessary to carry out the scheduled maintenance operations described below. The maintenance operations can essentially be classified according to the frequency with which they need to be performed:

- Daily maintenance operations;
- Monthly maintenance operations;
- Twice-yearly maintenance operations.

The operations require different levels of operator qualification. The following paragraphs describe the recommended procedures.

10.1. DAILY MAINTENANCE OPERATIONS



These operations can be carried out by the machine owner and do not require any special skills.

The **daily** machine maintenance consists of simple external cleaning, for the purposes of general hygiene.

For the daily maintenance of the machine, proceed as follows:

10.1.1. SETTING UP THE OPERATION



Only for 500, 700 and 700E models.

1. Turn off the machine by placing the switch in position 0 (OFF).
2. Unplug the mains lead from the wall outlet.

10.1.2. EXTERNAL CLEANING OPERATIONS

1. Using a cloth moistened with a neutral detergent (non acidic), clean the entire machine, taking care not to rub too vigorously, especially on the keys of the display.



Never spray the cleaning product directly on the machine.



WARNING: do not use alcohol, petrol or other chemical products.

10.2. MONTHLY MAINTENANCE OPERATIONS



These operations can be carried out by the machine owner and do not require any special skills.

The **monthly** maintenance operations consist of simple checks on the machine's operation and state of wear, to ensure its safe and correct functioning.

For the monthly maintenance of the machine, proceed as follows:

10.2.1. SADDLE CLEANING OPERATION

1. Clean the saddle carriage guide using a cloth moistened with a neutral detergent (non acidic).



WARNING: do not lubricate the saddle carriage guide.

10.2.2. CHECK WEAR OF FOOT STRAPS

1. Check the state of wear of the foot straps. Replace if there are evident signs of wear.

10.2.3. CHECKING THE OPERATION OF THE CARDIOTESTER RECEIVER

1. Using a separate heart rate monitor, put on the transmitter band and check that the machine and the separate monitor both measure the same heart rate, and that when the band is disconnected the machine does not receive any signal.
2. Using a heart rate frequency simulator, check that the machine detects variations in the heart rate.

10.2.4. CHECKING THE OPERATION OF THE HAND SENSOR RECEIVER



Only for 700, 700 SP and 700E models.

1. Using a separate heart rate monitor, grasp the hand sensors and check that the machine and the separate monitor both measure the same heart rate, and that when the sensors are released the machine does not receive any signal.

10.3. TWICE-YEARLY MAINTENANCE OPERATIONS



These operations can only be carried out by a qualified technician specifically trained by Technogym and authorized to carry out machine installation and adjustments, as well as special maintenance operations or repairs which require special knowledge of the machine, its operation, safety systems and working procedures.

The **twice-yearly** maintenance operations involve checking the functioning, wear and tension of the mechanical components so as to ensure the correct and safe operation of the machine.

For the twice-yearly maintenance of the machine, proceed as follows:

10.3.1. CARRYING OUT THE MONTHLY MAINTENANCE PROCEDURE

1. Carry out the procedure described in paragraph 10.2. “Monthly maintenance operations”.

10.3.2. SETTING UP THE OPERATION



Only for 500, 700 and 700E models.

1. Turn off the machine by placing the switch in position 0 (OFF).
2. Unplug the mains lead from the wall outlet.

10.3.3. CLEANING OPERATIONS

1. Use a vacuum cleaner to clean the interior, paying particular attention to the brake.



WARNING: when carrying out these operations, be careful not to damage the cables.

10.3.4. CHECKING THE WORKING CONDITIONS



Only for 500, 700 and 700E models.

1. Using a multimeter, check that the machine earth node is correctly connected to earth.

10.3.5. CHECKING THE WEAR OF RUBBER PARTS

1. Check the state of wear of the rubber components. Replace if there are evident signs of wear.

10.3.6. CHECKING THE BELT

1. Check the state of wear of the belt, using the pulley to turn it by hand, paying special attention to the edges and the inner part. Replace if there are evident signs of wear.
2. Also check the tension of the belt.

10.3.7. CHECKING THE DISPLAY

1. Check the operation of all the keys on the keyboard.
2. Check the operation of all the LEDs and the buzzer.

10.3.8. CHECKING THE WIRING AND CONNECTIONS

1. Check the condition of all the cables:

- External conditions;
- Possible rusting of the connectors;
- Electrical continuity of the individual wires;
- Isolation of the individual wires toward ground.

Repair and/or replace any non-conforming wires.



Only for 500, 700 and 700E models.

2. Check the condition of the fuses using a tester (only 500 and 700 models).

11. APPENDIX

11.1. UPDATING THE SW

To update the machine SW it is necessary to change the contents of the FLASH EPROM on the 386 board by means of an external PC connected to the CSAFE port on the machine, situated on the lower part of the display panel.



The PC can only update the FLASH EPROM while the machine is being switched on, before the power-on reset procedure begins.

11.2. COMPATIBILITY BETWEEN HW AND SW

11.2.1. CPU HW VERSION FOR WELLNESS TV

HW version	SW version
revision E	3.18.0 or lower
revision F	higher than 3.18.0

11.3. REQUIRED TOOLS

The following tools are required for carrying out the various disassembly, adjustment and maintenance action on the machine:

- Small Phillips screwdriver;
- Medium Phillips screwdriver;
- 7-mm wrench;
- 15-mm wrench;
- 17-mm wrench;
- 24-mm wrench;
- 2.5-mm Allen T-wrench;
- 3-mm Allen T-wrench;
- 4-mm Allen T-wrench;
- 6-mm Allen T-wrench;
- 14-mm socket wrench;
- 25-mm Torx wrench;
- Snap ring pliers;
- Bicycle pedal extractor;
- Torque wrench;
- Flatness comparator.

 **ATTENTION: The tool sizes are expressed in mm.**



TECHNOGYM S.p.A.
Via G. Peticari, 20
47035 Gambettola (FC)
ITALIA
Tel.: +39-0547-650438
Fax: +39-0547-650150
e-mail: service@technogym.com