

SPORTSART *C52r*

OWNER'S MANUAL

ASSEMBLY INSTRUCTIONS



SPORTSART C52R RECUMBENT BIKE

TABLE OF CONTENTS

A. SAFETY GUIDELINES.....	1
B. INTRODUCTION.....	2
C. ASSEMBLING YOUR CYCLE	
Installation requirements.....	3
List of parts.....	3
Step-by-step instructions.....	4
Floor level adjustment.....	12
Seat adjustments.....	13
D. EXERCISING ON YOUR CYCLE	
Understanding the electronics package.....	16
Electronic display.....	16
Terminology.....	17
Display function.....	18
Basic operation.....	19
System default setting.....	21
E. PROGRAMS	
Manual program.....	22
Hill program.....	24
Random program.....	24
INT1 program.....	24
INT2 program.....	25
WT loss (HRC 65%) / Cardio (HRC 80%) programs.....	26
Cool down mode.....	28
Power standby mode.....	29
F. MAINTAINING C52R CYCLE.....	30
G. EXERCISE GUIDELINES	
How long should I exercise?.....	30
How often should I exercise?.....	30

A. SAFETY GUIDELINES

Please read and observe the following safety guidelines:

- Keep this owner's manual for future use and reference.
- Read this owner's manual and follow the instructions.
- Assemble and operate the bike on a solid, level surface.
- Never allow children on or near the bike.
- Check the machine before use. Make sure all parts are assembled, and all nuts and bolts are tightened. Do not use the machine if the unit is disassembled in any way.
- Keep your hands away from moving parts.
- Wear proper workout clothing: Do not wear overly loose clothing. Do not wear shoes with leather soles or high heels. Tie all long hair back.
- Do not rock the unit from side to side, and use care when mounting and dismounting the unit.
- Do not stand on the unit.
- Do not use accessories that are not specifically recommended by the manufacturer as these might cause injuries or cause the unit to fail.
- Allow sufficient space on both side of the cycle for users to mount and dismount the machine.
- If any parts fail or are defective, please stop your workout immediately and contact your authorized dealer for repairs.
- Work within your recommended exercise level; do NOT work to exhaustion.

CAUTION:

Before beginning any exercise program, you should consult with your doctor. It is recommended that you undergo a complete physical examination.

B. INTRODUCTION:

Congratulations on the purchase of one of the finest pieces of exercise equipment on the market, the SportsArt C52R. Constructed of high quality materials and designed for years of trouble free usage, the C52R will be an integral part of your fitness regimen.

Before using your C52R cycle, we recommend that you familiarize yourself with this Owner's Manual. Whether you are a first time user of an exercise cycle or a seasoned "pro", understanding the correct use of the equipment will enhance your ability to achieve your exercise goals safely and successfully.

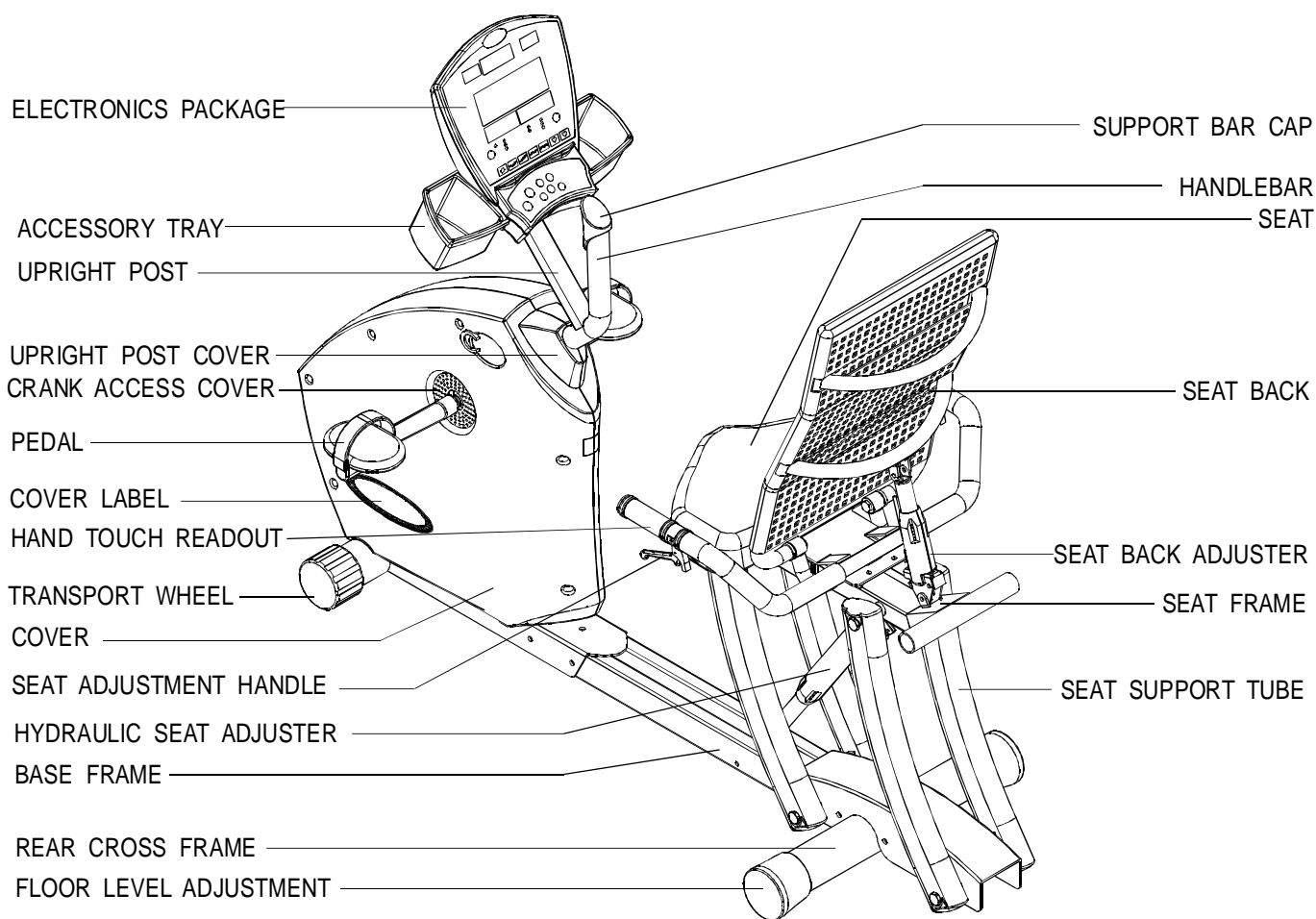

C. ASSEMBLING YOUR CYCLE

INSTALLATION REQUIREMENTS:

Read this owner's manual and follow the instructions contained herein.

Important: The packaging for this unit was designed to protect it during shipment.
Please store the original packaging in a safe place in case you need to ship the unit in the future.

LIST OF PARTS:

1. Four 5/16" x L19 bolts and four 5/16" flat washer – Rear cross frame
2. One pair of pedals
3. Three 5/16" x L19 bolts – Electronic display post assembly
4. Three M8 (5/16") internal serrated washers – Electronic display post assembly
5. Three 5/16" x L12 bolts – Seat base support frame
6. Four 5/16" x L19 bolts, four 5/16" spring washers and four 5/16" flat washers – Seat assembly
7. Four M5 x L10 bolts – Handlebar assembly
8. One M5 hex Allen wrench
9. One 2-way screwdriver
10. One green handle
11. One M14 x 15 open end wrench

STEP-BY-STEP INSTRUCTIONS:

When you remove the bike from its box, first check to make sure all of the parts are present. Then, read the assembly instructions thoroughly before you begin.

1. Take out the cycle frame and make sure all packing materials are removed from the unit.
2. Place this recumbent bike on a level, flat surface.
3. Assemble the rear cross frame onto the cycle. Then tighten four washers and screws. (See Fig. 1)

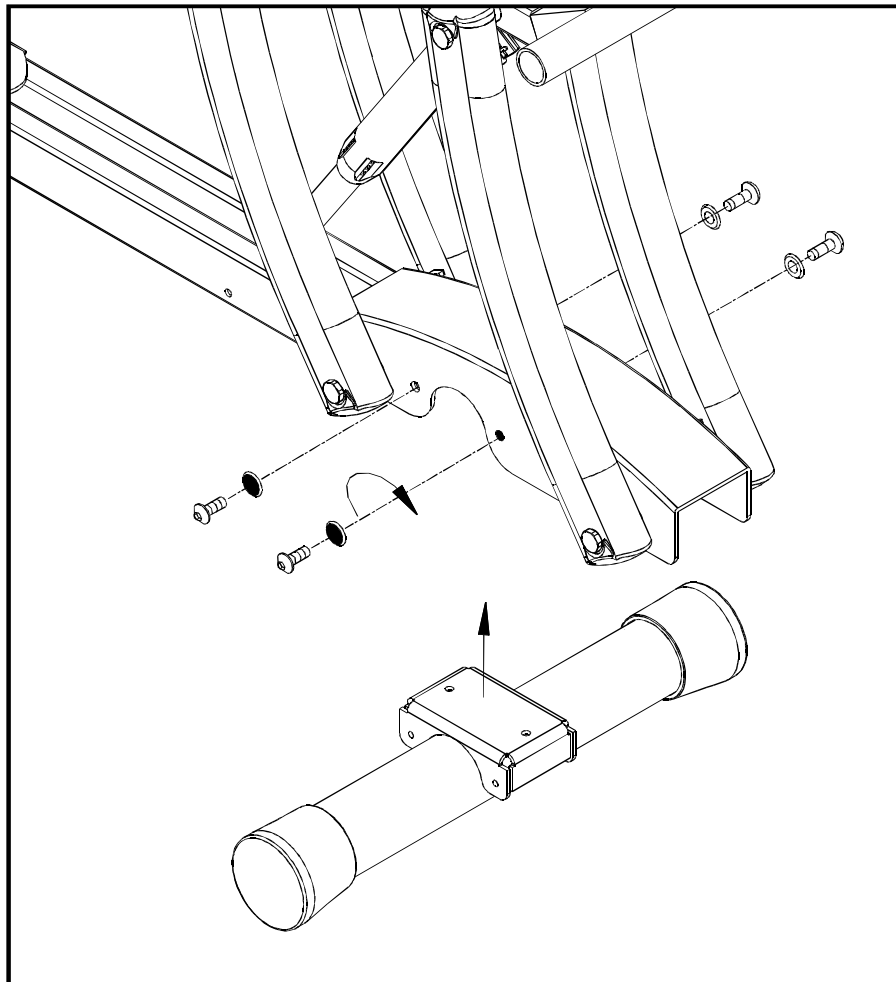

Fig.1

4. Attach the foot pedals to the crank arms on the cycle using the wrench provided. Be careful to install the pedals on the correct crank arm. "R" indicates the right side. "L" indicates the left side.

Install the pedal marked "R" on the right side crank arm (as you stand at the rear of the cycle facing to the front). When you install the pedal on the left side crank arm, rotate the pedal counterclockwise to tighten. (See Fig. 2)

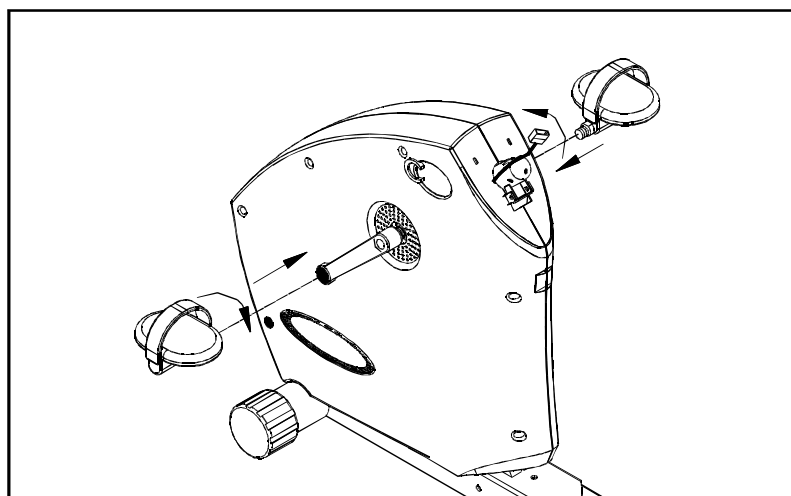

Fig.2

5. Connect the ribbon cables. (See Fig. 3)

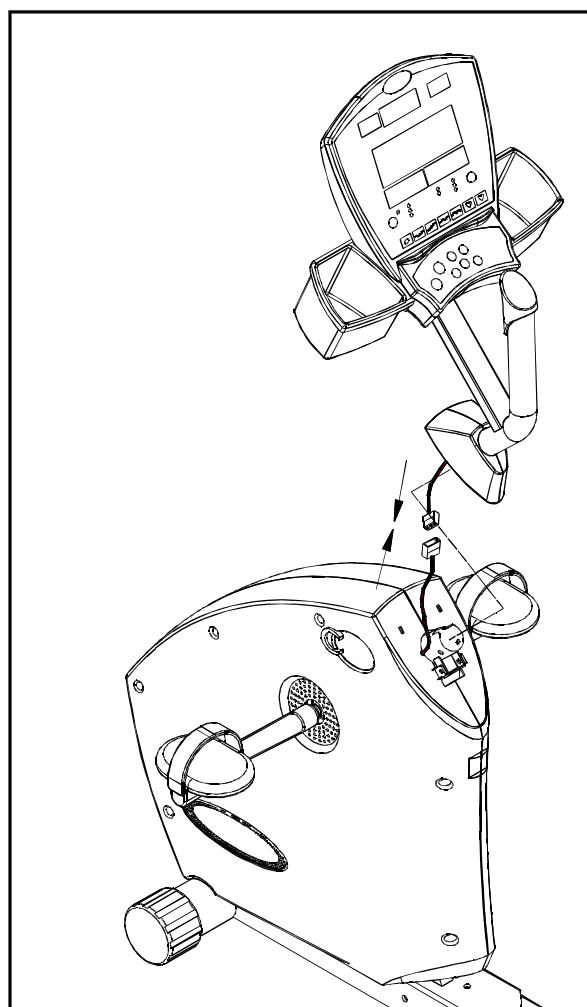

Fig.3

There are three screws to fix the electronic display post. Please secure the middle screw first that is on the top of the electronic display post. Please align the upright post before you tighten this middle screw. Then secure other two side screws. This step will help center the upright post. (See Fig. 4)

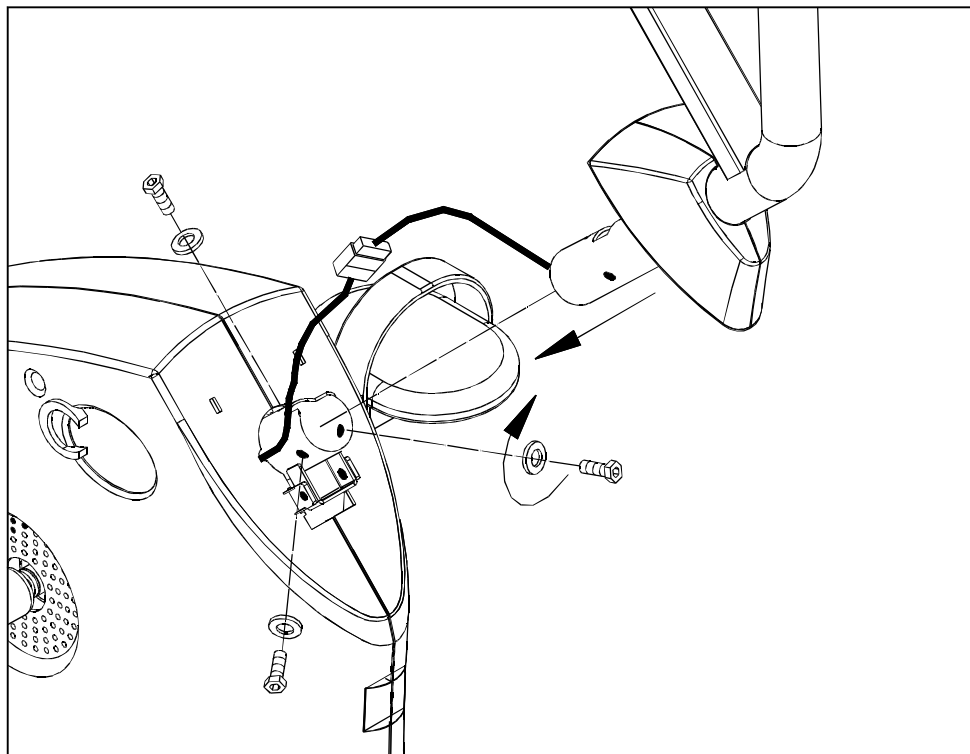

Fig.4

There is a small hole on the top of the big cover. Click the electronics display post cap onto the big cover. (See Fig. 5)

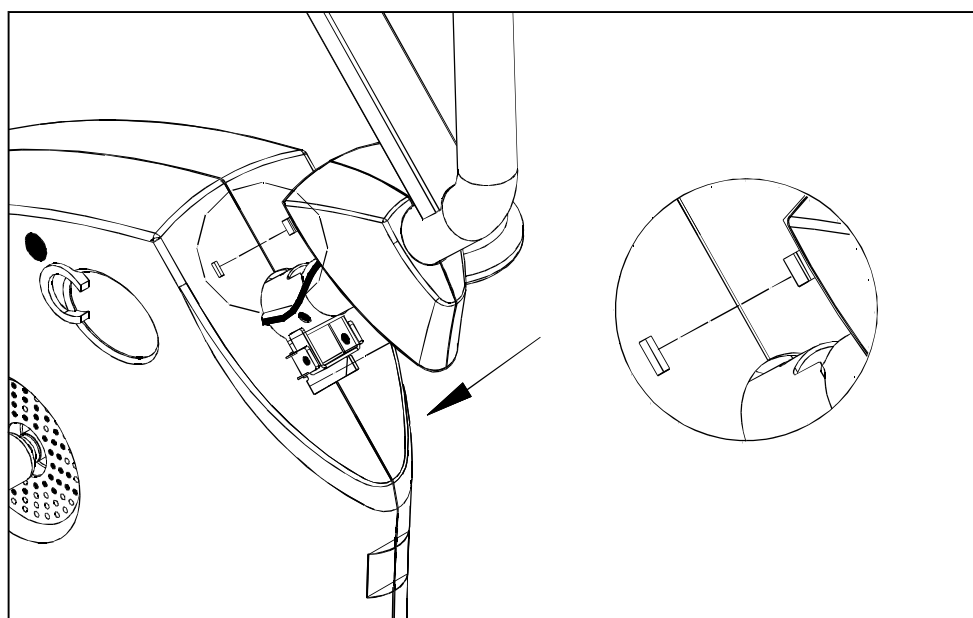

Fig.5

6. Follow the direction to put the seat base support frame onto the right position. And connect the ribbon cables (R↔R, L↔L). (See Fig. 6)

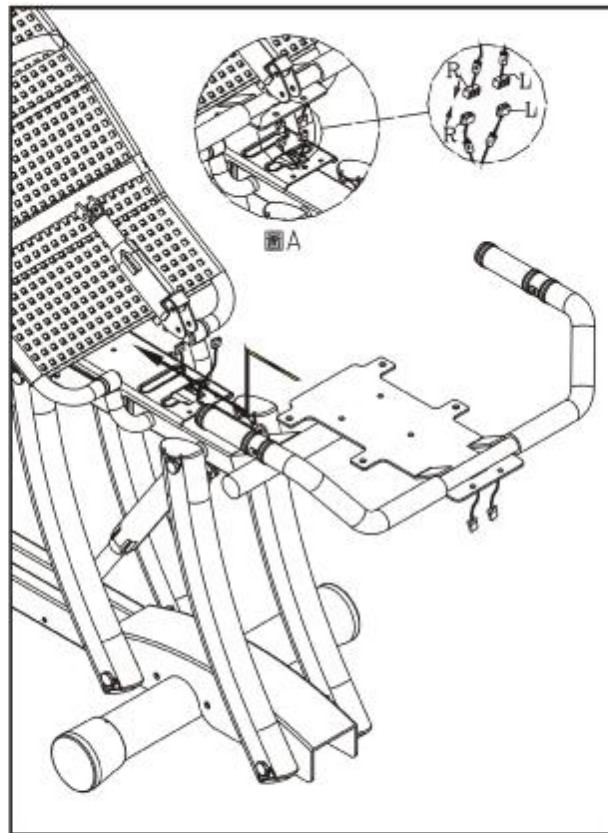

Fig.6

7. Tighten the three screws to secure the seat base support frame. (See Fig. 7)

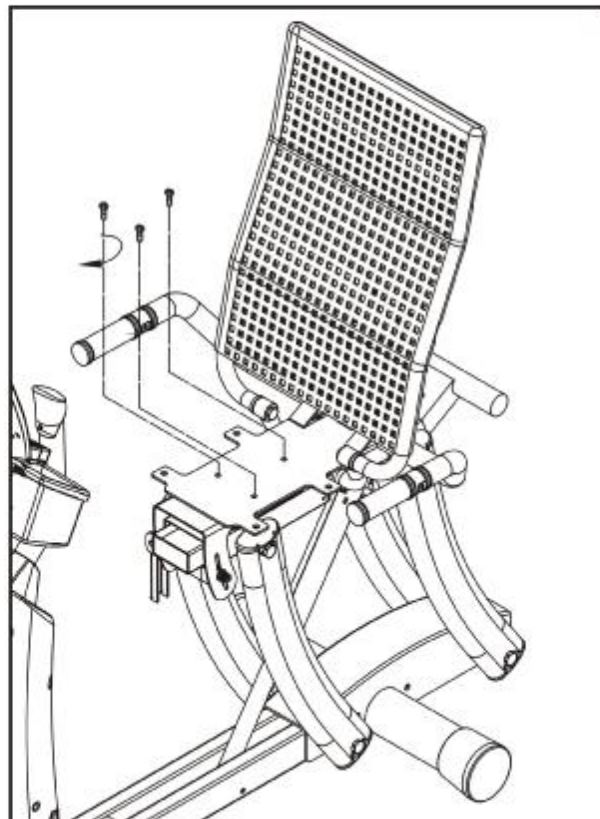

Fig.7

8. Push back the seat back to the right position. Then put the seat back adjuster to the hole, and fix it with one pin and one R-shape pin. (See Fig. 8)

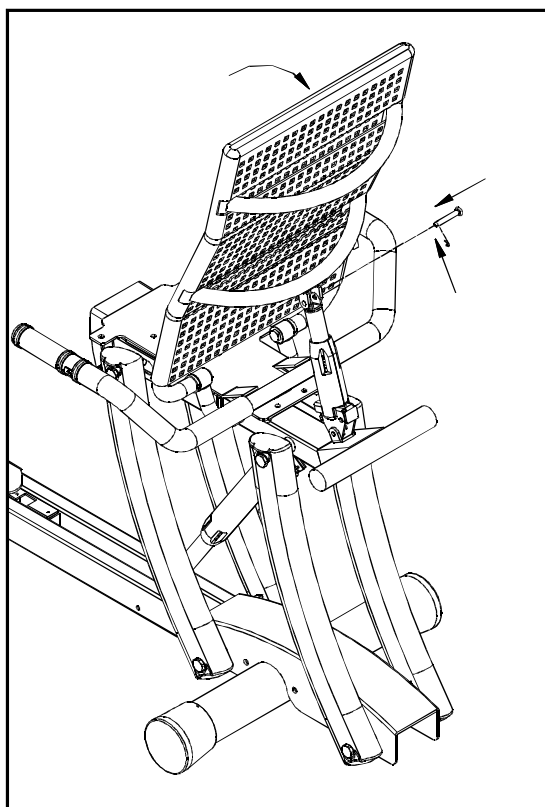

Fig.8

Attach seat base in the position shown below, then tighten the seat with the 4 sets of washers and screws. (See Fig. 9)

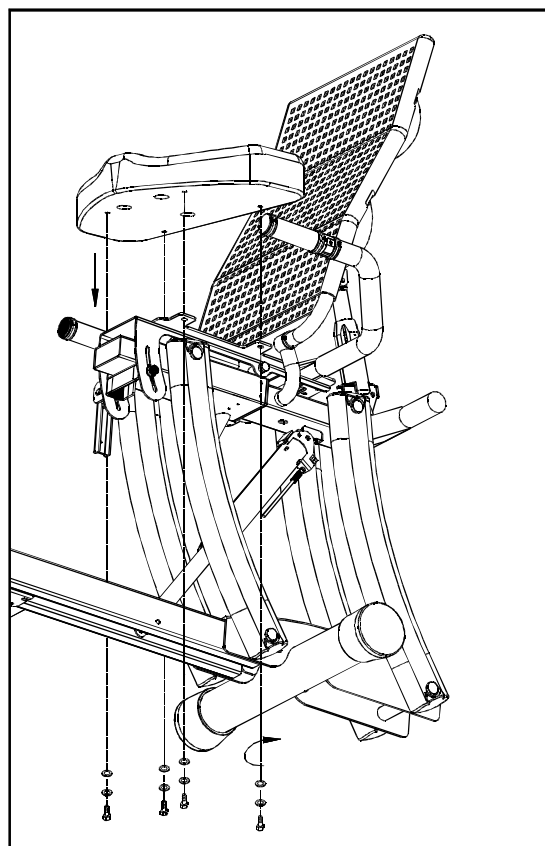

Fig.9

9. Attach the seat back adjustment handle to the right side of handlebars, and then tighten it by using 2 screws. (See Fig. 10)

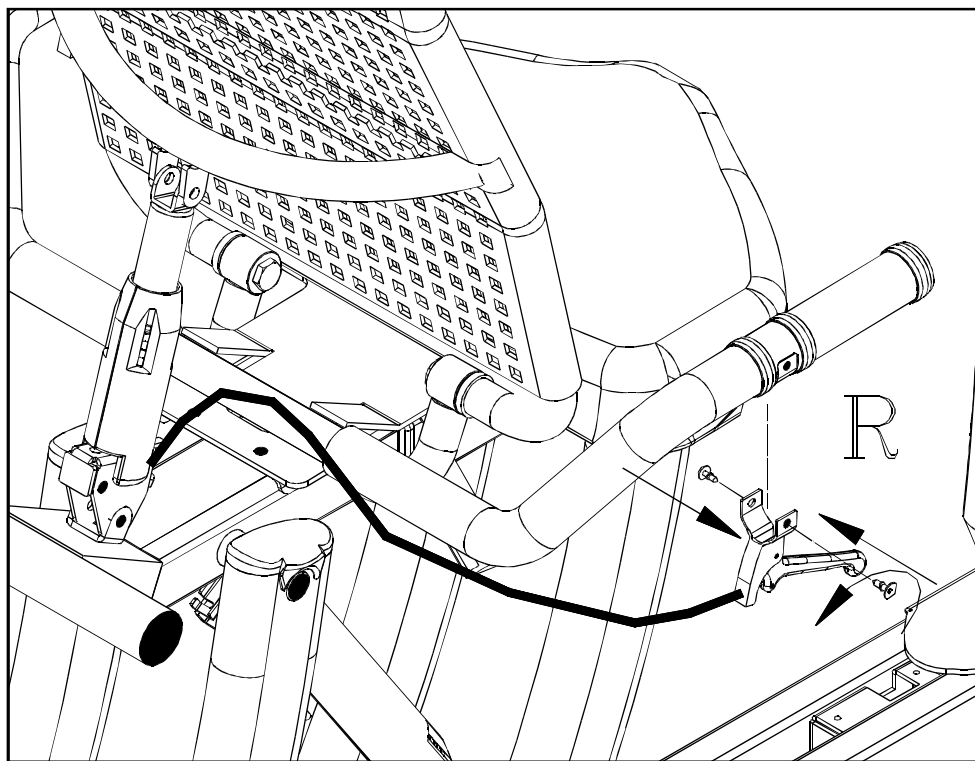

Fig.10

- Attach the seat adjustment handle to the left side of handlebars, and then tighten it by using 2 screws. (See Fig. 11)

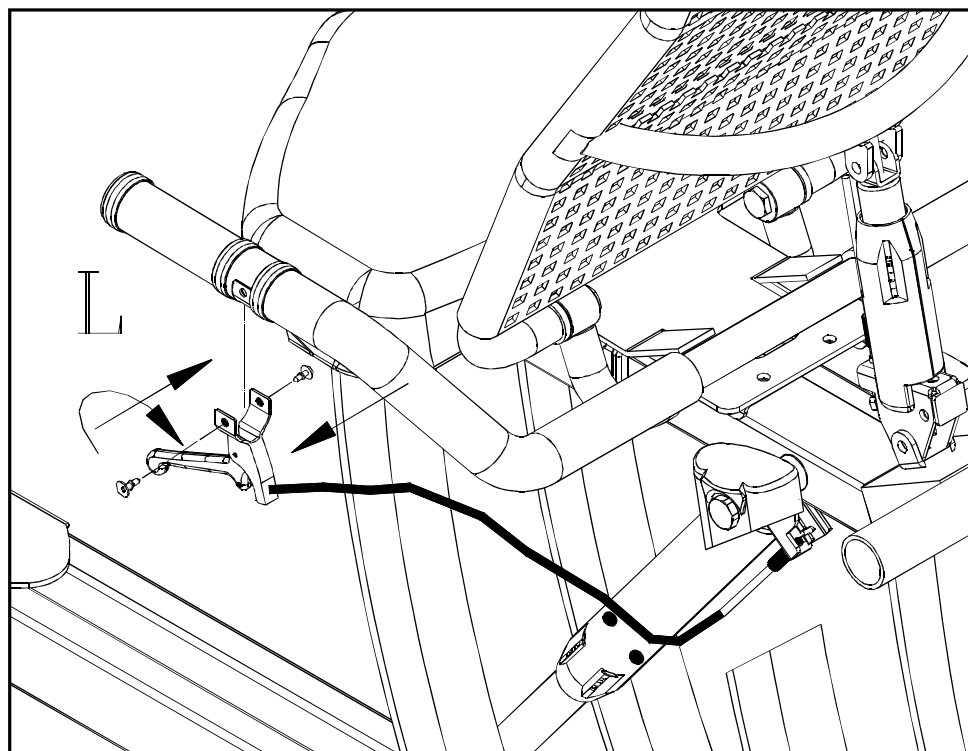

Fig.11

PRODUCT LENGTH ADJUSTMENT:

1. Please rotate the floor lever adjustment to the most lowest position as ①. Put a wood ② underneath the base tube to balance correctly when you loosen screws. The placement for this wood should be close to the screw position as the oblique indicated. (If you miss the wood in the future, the replacement part proposed is about 4 in length and 7/8" in height, something like, magazine, book - - - is also accepted. (See Fig. 11)

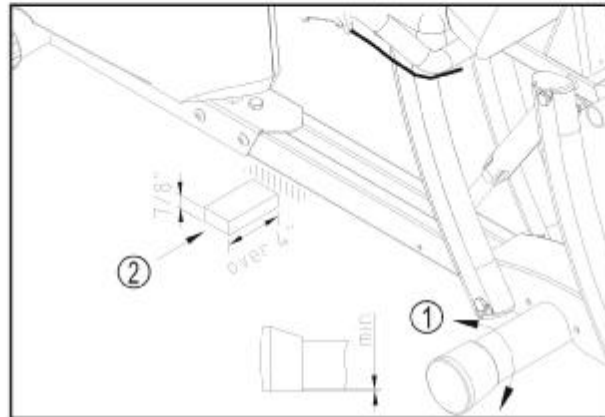

FIG.11

2. Please loosen and move out 4 screws. (See Fig. 12)

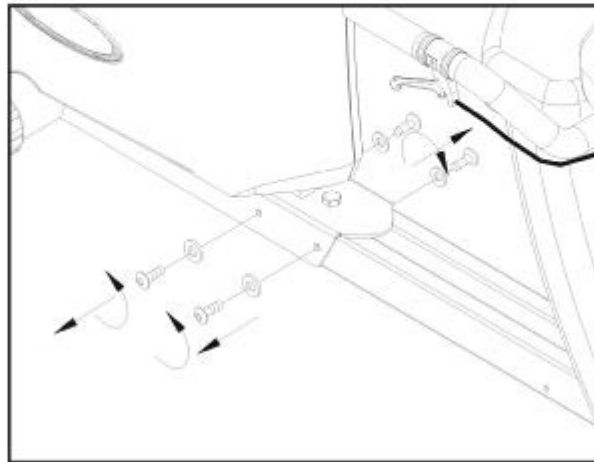

FIG.12

3. Loosen this screw show as the picture for moving the front unit, but don't remove this screw. (See Fig. 13)

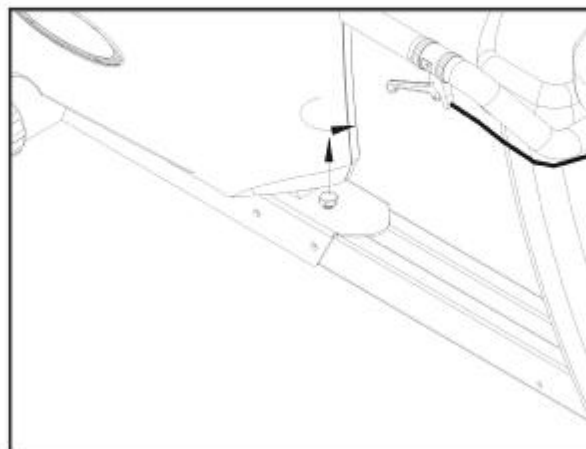

FIG.13

4. Adjust the front unit forward or backward to the appropriate screw hole to meet your body size. Move in direction A for a longer stride length. Move in direction B for a shorter length.

Note: This product is shipped at the shortest stride length location. (See Fig.15)

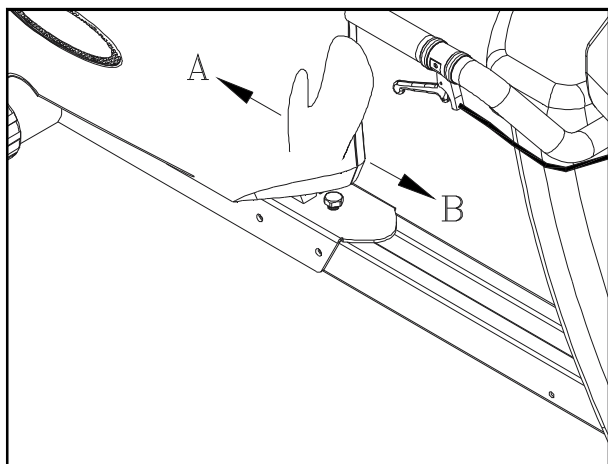

FIG.15

5. Please attach 4 screws, but don't tighten yet after you adjust the appropriate stride length. (See Fig.16)

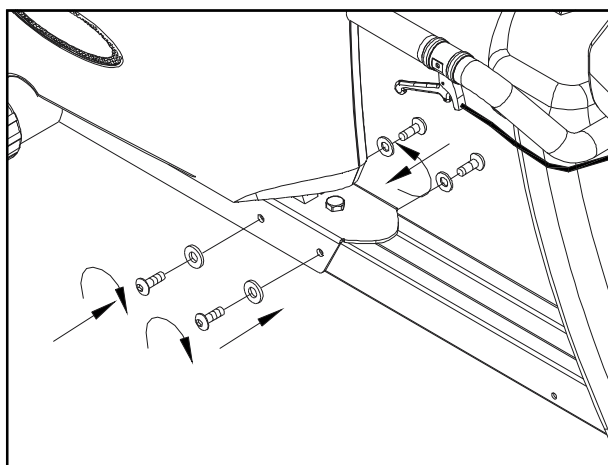

FIG.16

6. Please tighten this screw on the top of the tube. Then fasten 4 side screws again. (See Fig.17)

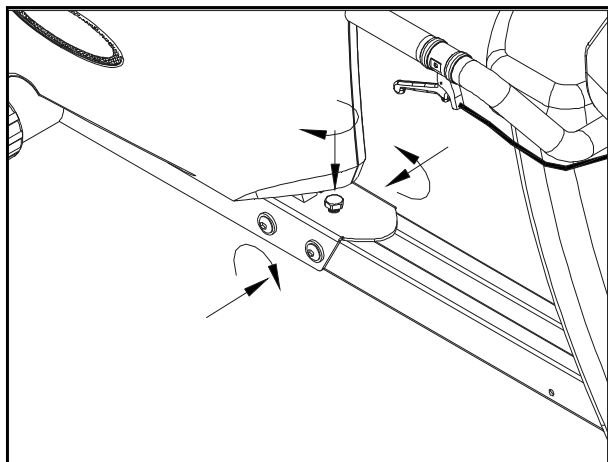

FIG.17

FLOOR LEVEL ADJUSTMENT:

Rotate floor level adjustment to steady the bike. (See Fig. 18)

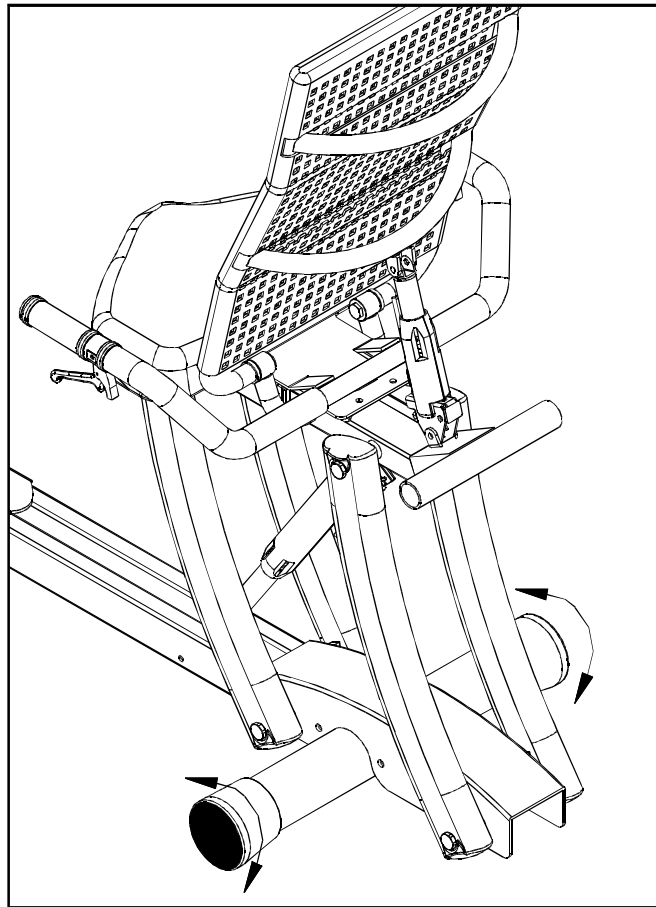

Fig.18

SEAT ADJUSTMENTS:

1. Change seat position

NOTE: The whole seat including the seat support tubes can move forward and backward.

Move forward: One hand presses on the seat adjustment handle (left side of handlebars), and push the seat forward. To make you easier to move forward, we propose the right hand holds the support bar (C).

Move backward: One hand presses on the seat adjustment handle (left side of handlebars), and push the seat backward. (See Fig. 19 & 20)

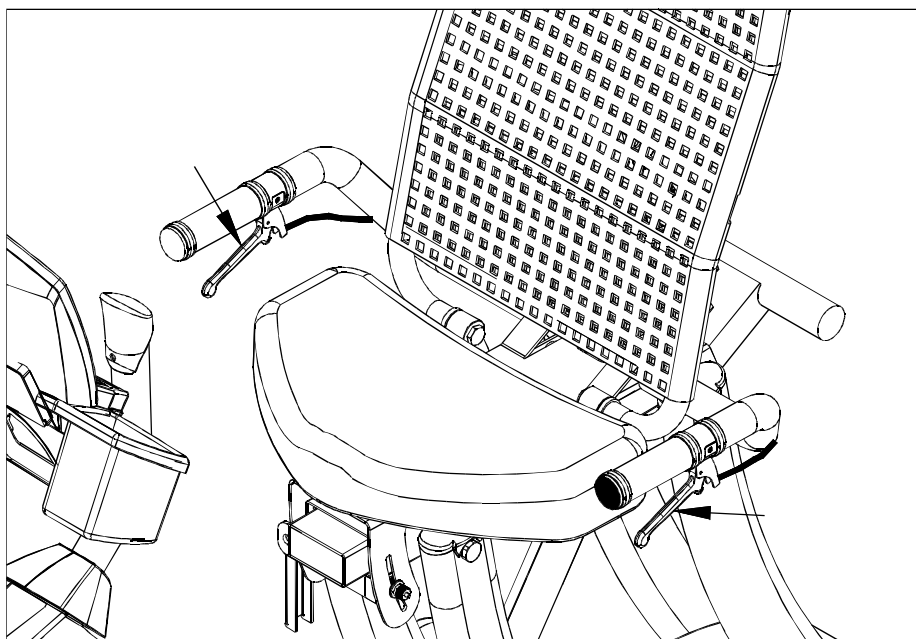

Fig.19

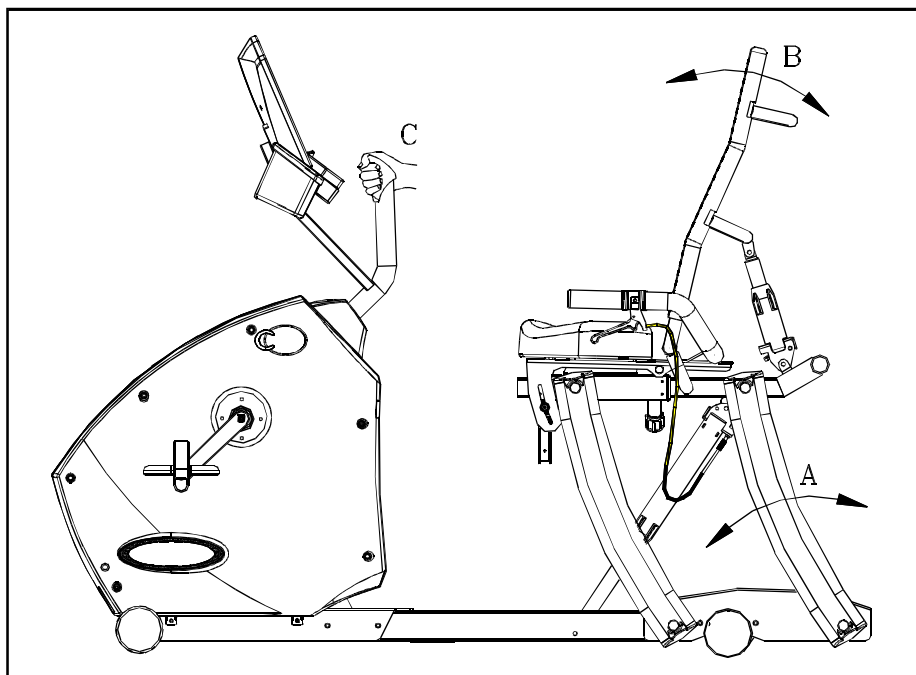

Fig.20

2. Change seat back position

Raise seat back position: Press seat back adjustment handle (right side of handlebars), and leave seat back to arise back position.

Lower seat back position: Press seat back adjustment handle (right side of handlebars), and push seat back to lower back position.
(See Fig. 19 & 20)

3. Change seat position

NOTE: Only seat can move forward and backward.

Turn the adjustment knob (A) counterclockwise until it is loose, and adjust seat to the desired position. Then tighten the knob (A) clockwise to secure the seat.
(See Fig. 21)

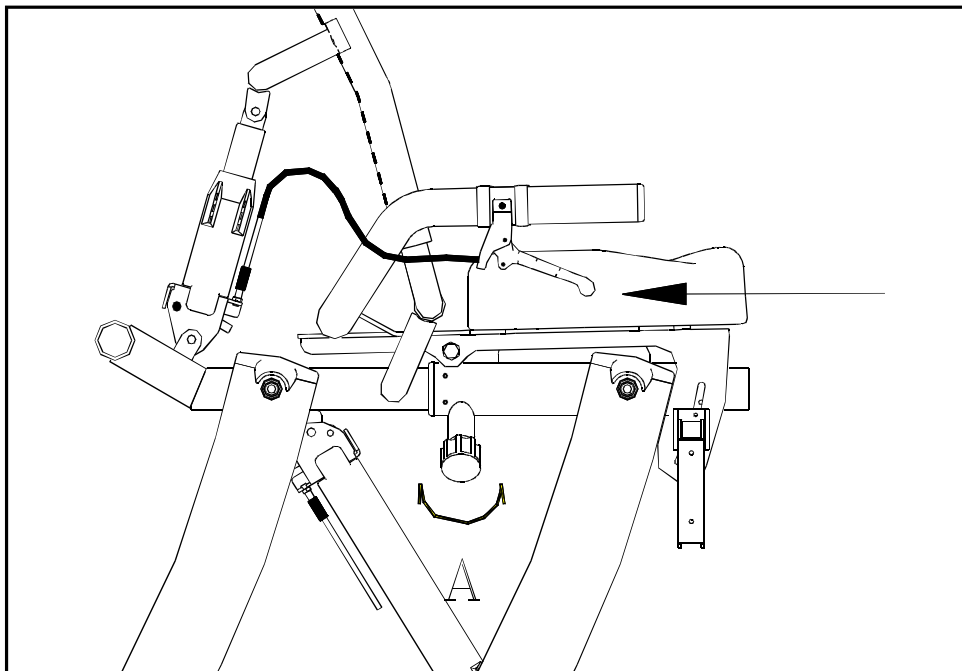

Fig.21

4. Change seat angle

Raise the adjustment lever (B) to loosen the seat. Adjust seat angle to the desired position, then press down the lever to tighten the seat. (See Fig. 22)

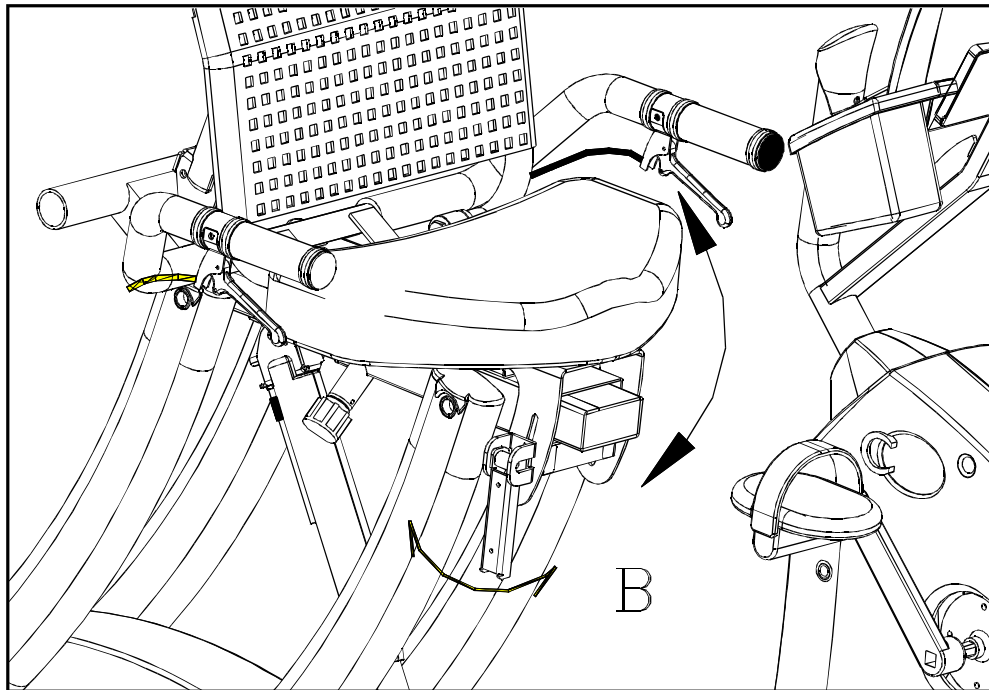

Fig.22

Your C52R cycle is assembled and ready to use.

D. EXERCISING ON YOUR CYCLE

Understanding the Electronics Package

Electronic Display (See Fig. 23)

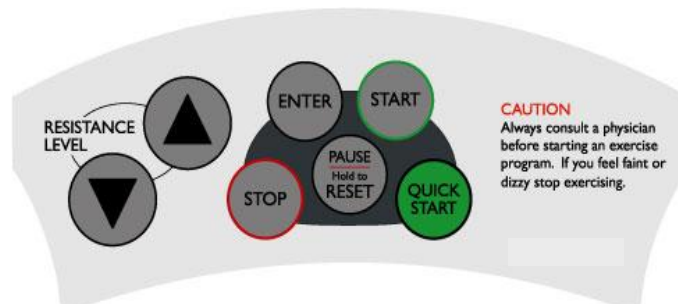
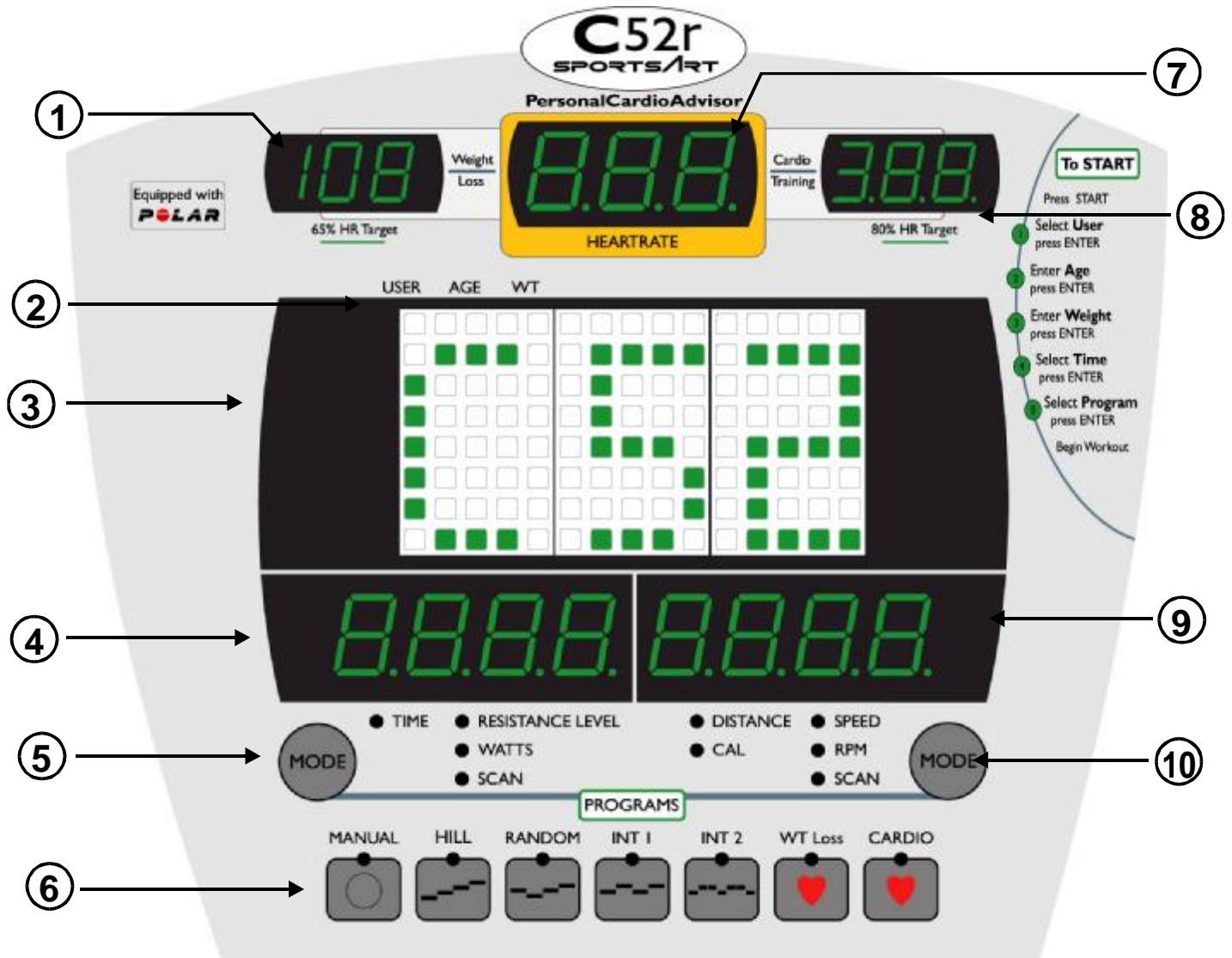

1. Weight Loss (65% HR Target): Using age as a factor, the Personal Cardio Advisor automatically calculates your optimal heart rate for weight loss. The optimal weight loss target heart rate is 65% of the maximum workout heart rate for your age. This figure becomes the target heart rate for your weight loss workout.
2. USER, AGE, WT: User data for workout.
3. Dot matrix display: Provides prompts & program status information.
4. Window 1: Displays TIME, RESISTANCE LEVEL, WATTS, and accumulated workout time.
5. Mode – left: To switch between TIME, RESISTANCE LEVEL, WATTS, SCAN.
6. Programs: MANUAL, HILL, RANDOM, INT1, INT2, WT Loss, CARDIO.
7. Heartrate: Shows the user's actual heart rate.
8. CARDIO (80% HR Target): Using age as a factor, the Personal Cardio Advisor automatically calculates your optimal heart rate for cardio conditioning. The optimal cardio conditioning workout is 80% of the maximum workout heart rate for your age. This figure becomes the target heart rate for your cardio conditioning workout.
9. Window 2: Displays DISTANCE, CAL, SPEED, RPM, and accumulated workout distance.
10. MODE – right: To switch between DISTANCE, CAL, SPEED, RPM, SCAN.

Terminology

- A. TIME: Displays total time accumulated or time remaining in a programmed workout.
- B. WATTS: Displays the exertion level in WATTS.
- C. DISTANCE: Displays total miles or kilometers.
- D. CAL: Displays overall caloric expenditure of the present workout.
- E. SPEED: Displays the current speed in MPH/KPH (depends on national standard).
- F. RPM: Revolutions per minute.

G. SCAN – left: Displays TIME, RESISTANCE LEVEL, WATTS in a 4 seconds interval.

H. SCAN – right: Displays DISTANCE, CAL, SPEED, RPM in a 4 seconds interval.

Display Function

A. MODE – left side button: Press to choose information modes: TIME, RESISTANCE LEVEL, METS, WATTS, SCAN.

B. MODE – right side button: Press to choose information modes: DISTANCE, CAL, SPEED, RPM, SCAN.

C. QUICK START: Press to start working out without setting USER, AGE, WEIGHT, TIME settings.

D. START: (1) Press START to start programming your workout.

(2) In the PAUSE mode, press START or start pedalling to resume your workout.

E. STOP: (1) Press STOP to end your workout. Workout data will be displayed.

(2) When cooling down, press STOP to end 'cool down' function.

F. PAUSE/RESET: (1) Pause: Press PAUSE/RESET and stop pedaling to retain program and workout memory. "PAUSE" will scroll across Window 1&2 and the unit will enter standby mode. To return to your workout, press START or pedal for over 2 seconds.

(2) Reset: Press and hold PAUSE/RESET for 2 seconds. All data will reset and the display will return to Banner mode.

G. ENTER: Press to enter your input data.

H. UP▲ / DOWN ▼ : Press ▲ or ▼ to select USER ID, AGE, WEIGHT, TIME, and RESISTANCE LEVEL.

I. MANUAL, HILL, RANDOM, INT1, INT2, WT Loss, CARDIO: Press to select your desired program.

Basic Operation

1. Power up the bike:

Turn on the unit by pressing START or by pedaling (speed must be over 30RPM). The "C52" banner message appears, then "USER" appears within 1 second.

2. Select USER:

2-1: The USER indicator flashes and a starting number "1" (means USER 1) appears in the middle of the dot matrix display window. Press ▲ or ▼ to select USER1 through USER 4, and then press ENTER to confirm your choice.

2-2: When the USER number and data appear, the total accumulative workout TIME appears in Window 1; and the total accumulative workout DISTANCE appears in Window 2. The relevant target heart rate values for Weight Loss and Cardio Training also appear on 65% HR Target and 80% HR Target windows.

Note: If no memory exists for the chosen USER number, values do not appear in windows.

2-3: How to clear the USER's record?

In the desired user setting, for example, USER1, simultaneously press START and STOP buttons for 3 seconds. The memory for USER1 will be erased. WEIGHT and TIME will revert to the default setting: WEIGHT = 75 KG (or 165 LB); TIME = 30 minutes.

2-4: Memory always reverts to the last user. For example, if USER 4 is the last one to operate the cycle, USER 4 settings will automatically reappear the next time the cycle is operated. Press ▲ or ▼ to select USER1 through USER 4, and then press ENTER to confirm your choice.

3. Select USER ID (set user's name):

As shown in Basic Operation: **2.Select USER**, rather than using a USER1,2,3,4 number, you may input your name. To do so, choose "USER ID" rather than "USER".

3-1: Select the first letter or number:

In the USER section, simultaneously press and hold right and left MODE buttons for 3 seconds. The letter "A" appears and flashes in the dot matrix window. Press ▲, letters A~Z appear one by one, then numbers 0~9 appear similarly. Press ▼, numbers 9~0 appear one by one, then letters Z~A appear similarly. Press ▲ or ▼ to select a letter or number, then press ENTER to confirm your choice.

3-2: Select the second letter or number:

The chosen first letter or number moves to the left, and again letters A~Z and number 0~9 appear. Choose the second letter or number as indicated in 3-1.

Note: USER ID settings consist of 2 figures only.

4. Select AGE:

The AGE indicator blinks. A starting age of "35" appears in the dot matrix display window.

4-1: Press ▲ or ▼ to select your age, and then press ENTER to confirm your choice.

4-2: Using the AGE value, the Personal Cardio Advisor automatically calculates target heart rate values for Weight Loss (65% HR Target) and Cardio Training (80% HR Target).

Note: The allowable age range is 10~90 years old.

5. Select WEIGHT:

The WT indicator flashes. A starting weight of "75"(KG) or "165"(LB) appears in the dot matrix display window. Press ▲ or ▼ to select your weight, and press ENTER to confirm your choice.

Note: The allowable weight range is 20~160 KG or 45~350 LB.

6. Select TIME:

The TIME indicator flashes. Window 1 displays the time set by the previous user. Press ▲ or ▼ to select your time, and then press ENTER to confirm your choice.

Note: (1) The allowable time range is 5:00~99:00.

(2) If this is the first time in use, the unit automatically enters MANUAL mode. If desired, press another program button to operate the corresponding program.

(3) If a previous user selected a USER number or ID, the unit automatically enters the program selected by that user. If desired, press your desired program button to change the setting.

7. Select PROGRAM:

7-1: All PROGRAM indicators flash. The message "SELECT PROGRAM OR PRESS START" scrolls across the dot matrix display window.

(1) Press the desired program to begin your workout.

(2) Or Press START to return the "Select USER" section.

7-2: If you press QUICK START, the unit assumes you are a new user. Previously accumulated data reverts to zero.

8. At any time to skip USER and WEIGHT setting and get directly to your workout, press QUICK START. The TIME directly counts up from 00:00.

9. After completion of the workout, the unit enters COOL DOWN mode.

SYSTEM DEFAULT SETTING

1. Display Accumulated Distance:

In the USER section (before pressing any key), press ▼+ ▲+ ENTER simultaneously for 3 seconds, Window 1 & 2 display the total accumulated distance, a 6-digit figure. The DISTANCE indicator lights up. After that if you press ENTER, the TIME indicator lights up. The display shows up the total accumulated time.

Press ENTER to modify basic unit operation setting.

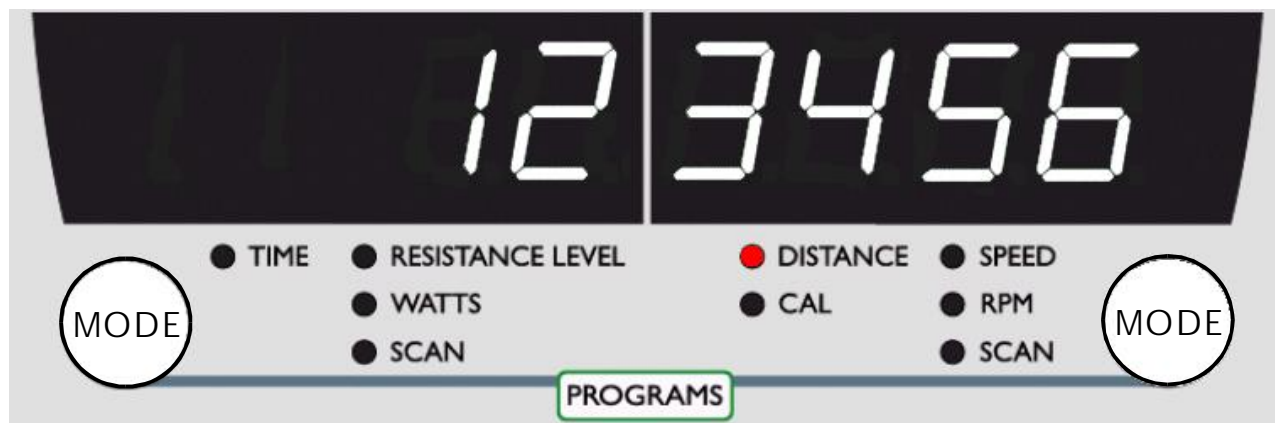

2. Select MODIFY:

- (1) "NO" is the pre_setting of MODIFY.
- (2) Once in the default setting, "MODIFY HRC Y OR N" scrolls across the dot matrix window, then "MDF" appears.
- (3) The HEARTRATE window shows either "NO" or "YES". Press ▲ or ▼ to modify your choice, then press ENTER. The unit returns to the starting screen, showing "C52". (Please refer to Page 27: 6-2 (a)&(b) for more details.)



E. PROGRAMS

1. MANUAL Program:

1-1: Press MANUAL to enter this mode. The dot matrix window shows the following:

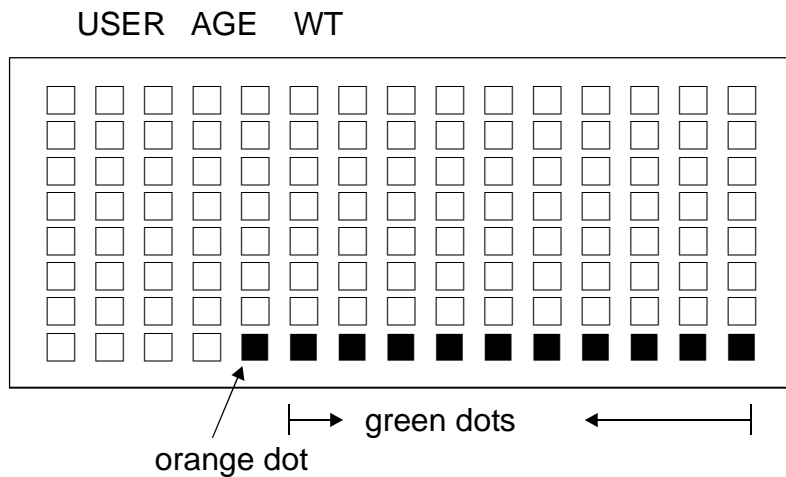

1-2: When the user begins pedaling, the orange dot flashes.

(a) Red dot – represents completed courses.

(b) Orange dot – represents current position.

(c) Green dot – represents upcoming courses.

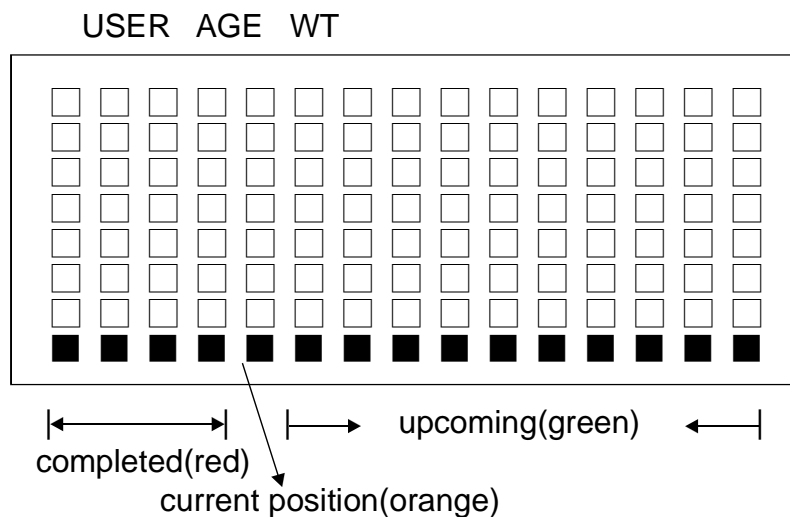

1-3: Press RESISTANCE LEVEL ▲▼ to adjust resistance at anytime during the workout. The height of the dots represents the resistance level: The higher the dots, the greater the resistance. The height of the dots automatically changes when resistance settings are changed.

1-4: The Orange dot(s) flashes and lasts for 20 seconds, then moves to the left as the workout progresses.

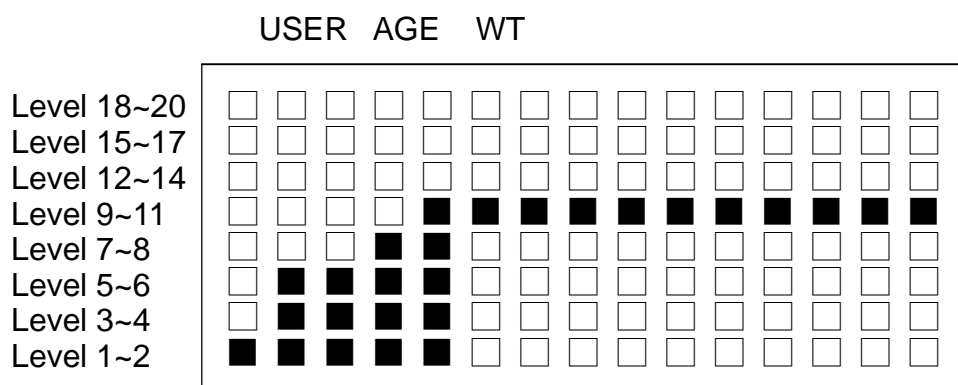

2. HILL Program:

2-1: There are 3 different HILL workouts. Press HILL to select the desired workout pattern: HILL 1→HILL 2→HILL 3.

2-2: The resistance level profiles of HILL patterns follow:

HILL 1: 2_4_6_8_6_4_2_4_6_8_6_4

HILL 2: 2_8_4_8_6_8_6_8_4_8_2_8

HILL 3: 2_4_6_8_10_12_14_12_10_8_6_4

2-3: Press RESISTANCE LEVEL ▲▼ to adjust resistance at anytime during workout.

2-4: The Orange dot(s) flashes and lasts for 20 seconds, then moves to the left as the workout progresses.

3. RANDOM Program:

3-1: Press RANDOM to select one of an infinite number of programs.

3-2: Press RESISTANCE LEVEL ▲▼ to adjust the desired level at anytime during workout.

3-3: The Orange dot(s) flashes and lasts for 20 seconds, then moves to the left as the workout progresses.

4. INT 1 Program:

4-1: This program consists of repeating segments. Each segment lasts one minute, and has a resistance level set by the user before the workout begins.

The default resistance level profiles of the 2 segments are as follows:

(a) Segment 1: LEVEL 1

(b) Segment 2: LEVEL 3

4-2: Press INT 1. The dot matrix window displays the following:

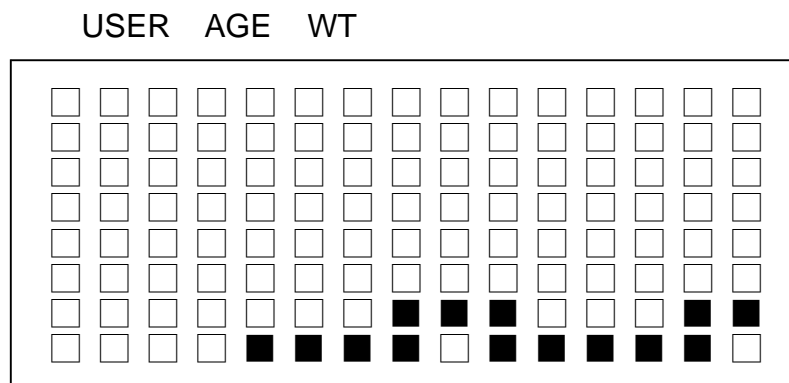

4-3: The user sets the resistance LEVEL for each segment in the workout. For instance, if the user sets segment 1 resistance to LEVEL 10, LEVEL 10 resistance applies to each segment 1 throughout the workout. However, resistance can be adjusted any time during workout.

4-4: The Orange dot(s) flashes and lasts for 20 seconds, then moves to the left as the workout progresses.

4-5: At the completion of each segment, "GOING TO LEVEL XX" scrolls across the dot matrix window, and the display beeps three times.

5. INT 2 Program:

5-1: IN2 consists of two segments with different time periods: segment 1 lasts one minute; segment 2 lasts two minutes. The user determines the resistance level of each segment at the start of the workout.

The default resistance level profiles of the 2 segments are as follows:

(a) Segment 1: LEVEL 3

(b) Segment 2: LEVEL 1

5-2: Press INT 2. The dot matrix window displays the following:

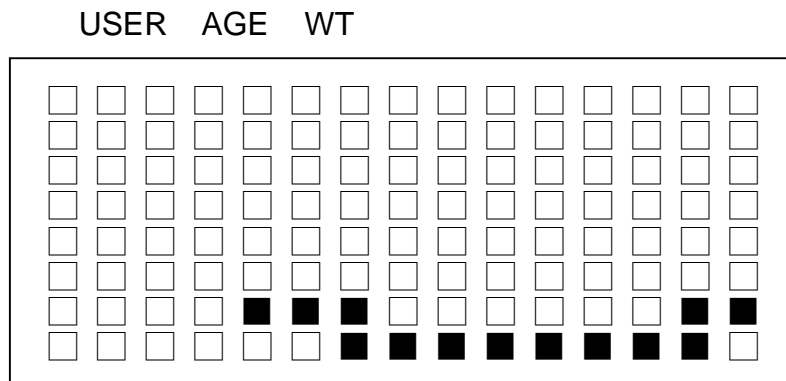

5-3: The resistance LEVEL of each segment is set at the beginning of the workout. For instance, if the user sets segment 1 resistance to LEVEL 10, LEVEL 10 resistance applies to each segment 1 throughout the workout. However, resistance can be adjusted any time during workout.

5-4: The Orange dot(s) flashes and lasts for 20 seconds, then moves to the left as the workout progresses.

5-5: At the completion of the current segment, "GOING TO LEVEL XX" scrolls across the dot matrix window, and the display beeps 3 times.

6. WT Loss (HRC 65%) / CARDIO (HRC 80%) Programs:

Heart Rate Control (HRC) includes two programs, one designed for weight loss (WT Loss) and another designed for an optimum cardio workout. WT Loss is a low intensity workout whereas CARDIO is a high intensity workout. These workouts are designed to achieve optimal workout results. The Polar transmitter belt must be worn properly to operate heart rate control programs.

6-1: Select either WT Loss or CARDIO workout. Age must be input for the display to calculate Target Heart Rate. Input your age, then press ENTER to confirm your choice.

Note: this procedure is skipped if the user has already input the age. (Please refer to Page 20 for Select AGE.)

The formulas of Target Heart Rate are as follows:

(a) Maximum Heart Rate = $220 - \text{AGE}$

(b) Target Heart Rate: Weight Loss = $(220 - \text{AGE}) \times 65\%$
Cardio Training = $(220 - \text{AGE}) \times 80\%$

6-2: Below is an example of the dox matrix window that shows the target heart rate to be 124 beats:

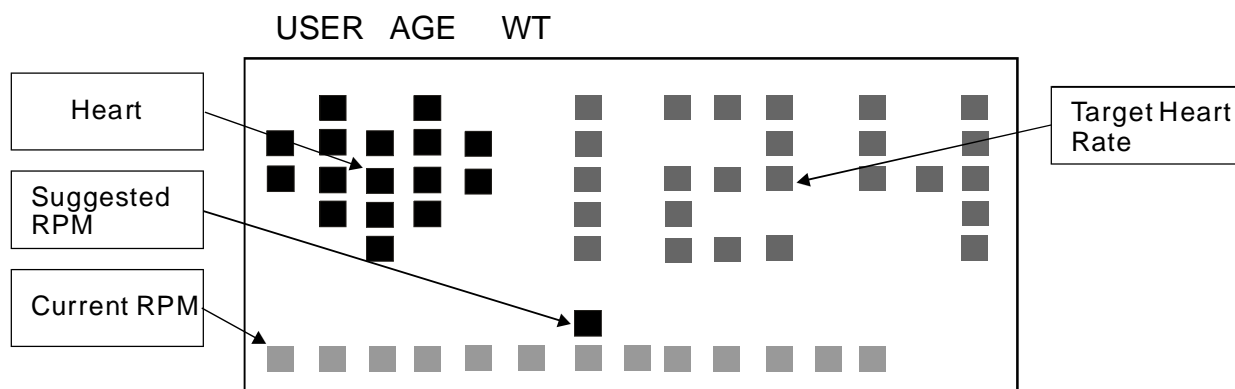

(a) 1. Heart: represents user's current heartbeat.

Note: During your workout, the heart (green & red colors rotate) on the display to indicate that your heart rate signal is clear. However, if the display does not detect a heart rate signal, the heart color remains green.

2. Suggested RPM (red flashing dot): represents user's suggested Revolutions per minute.

3. Current RPM: represents user's current Revolutions per minute.

4. Target Heart Rate: represents user's target heart rate.

(b) If the MODIFY setting is "YES", the figure of the target heart rate will become red and blink. Press ▲ or ▼ to adjust the target heart rate, then press ENTER to begin your workout.

Note: The heart rate figure cannot be set lower than 84 or higher than the maximum workout heart rate for your age.

(c) If the MODIFY setting is "NO", the target heart rate cannot be changed. (Please refer to Page 21 for **System Default Setting**.)

6-3: A Polar transmitter belt must be worn properly during workout to allow the heart rate signal to be successfully transmitted to receiver located inside the display console. A "NO HEART RATE READING" message will scroll across the dot matrix window if the display does not detect a heart rate signal for more than 3 seconds. Once the display can detect a heart rate signal again, the scrolling message will be gone, then will continue the heart rate function again.

6-4: The resistance level starts out at LEVEL 5; and RPM is 50. "SPEED UP" appears on the dot matrix window if your speed is under your lowest RPM (Your Suggested RPM – 10) for more than 25 seconds.

6-5: "PEDAL TO START" appears twice on the dot matrix window if no one exercises on the unit for more than 5 seconds. Resistance reverts to LEVEL 5; RPM reverts to 50 RPM; prompts appear every 5 seconds.

6-6: Window 1 toggles between TIME and LEVEL every 4 seconds. (It shows accumulated workout time and the resistance level.) When the scan indicator lights up, the MODE-left button will not operate.

7. COOL DOWN Mode:

After completing your desired workout program, accumulated data including TIME, CALORIES, DISTANCE, and HEART RATE appear.

7-1: After displaying the data, the display beeps once and enters COOL DOWN mode. The COOL DOWN program lasts 5 minutes. TIME indicator lights. In this mode, time counts down.

7-2: "GOING TO COOL DOWN" appears once on the dot matrix window, then the unit reverts to RESISTANCE LEVEL mode. The resistance decreases one level every 10 seconds.

7-3: When COOL DOWN mode ends, the display beeps once and "SELECT PROGRAM OR PRESS START" scrolls across the dot matrix window. (Please refer to Page 21 Select PROGRAM for more details.)

7-4: If you enter a PROGRAM without first establishing the USER ID, display reverts to the "Select USER" section after completion of the COOL DOWN process.

8. Power Standby Mode:

8-1: When no one exercises on the unit for more than 15 seconds, the cycle automatically enters power standby mode. One green dot scrolls across the dot matrix window.

8-2: When user starts pedaling or presses ENTER, the window reverts to the previous display.

IMPORTANT NOTICE

1. This cycle can record user settings for 4 users. Recorded settings include USER ID, accumulated distance, age, weight, INT1, INT2, and last workout program. (No data enters memory in QUICK START mode.)

The settings ranges follow:

- (a) USER ID: 2 figures
 - (b) Accumulative distance: 4 figures
 - (c) Age: 2 figures
 - (d) Weight: 3 figures
 - (e) INT1: 2 resistance levels
 - (f) INT2: 2 resistance levels
2. When changing programs during a workout:
 - (a) The workout illustration will change.
 - (b) The completed data will remain, and DISTANCE and CAL will continue to accumulate. And TIME will keep counting down.
 - (c) RESISTANCE LEVEL will change to the new program's level.
 3. When the user doesn't pedal or touch display buttons for 2 minutes, the cycle automatically turns off.
 4. The battery will be charged automatically if pedaling rate exceeds 25 RPM.

F. MAINTAINING C52R CYCLE

The SportsArt C52R cycle requires little maintenance, but smooth operation requires that the unit be kept as clean as possible.

Regular cleaning is recommended to keep your C52R at peak performance. Before your workout, use a dry cloth to clean the surface of the electronics package.

NOTE: NEVER POUR LIQUIDS ON ELECTRONIC PARTS.

To clean plastic parts, use mild detergent and make sure the unit is completely dry before operating. Keep all liquids away from the unit during operation. Spillage of liquids onto or into the machine will void the warranty.

G. GUIDELINES FOR EXERCISE

How long should I exercise?

The duration of your exercise session is dependent on your fitness level. In general, it is recommended that you maintain your heart rate in the training zone for at least 10 minutes to realize an aerobic benefit. As your fitness level improves, you will be able to maintain your heart rate in the training zone for longer periods.

When starting your workout, use the first several minutes to warm up, and then slowly increase your workload to bring your heart rate into your desired training zone. At the end of your workout, gradually decrease your workload, and then exercise lightly to "cool down".

How often should I exercise?

Aerobic exercise, to achieve the greatest benefit, should be performed 3-5 times a week. It is important to allow sufficient time, at least 24 hours, for your body to recover after exercise.