

# SPORTSART *C5150*

## *OWNER'S MANUAL* ASSEMBLY INSTRUCTIONS



# **SPORTS ART COMMERCIAL GRADE C5150** **GENERATOR SEMI-RECUMBENT CYCLE**

## **TABLE OF CONTENTS**

|   |    |
|---|----|
| A. SAFETY GUIDELINES .....                                | 1  |
| B. INTRODUCTION.....                                      | 2  |
| C. ASSEMBLING YOUR CYCLE                                  |    |
| List of parts.....  | 3  |
| Step by step instructions.....                            | 4  |
| Floor level adjustment.....                               | 8  |
| Seat adjustment.....                                      | 8  |
| D. UNDERSTANDING THE C5150 DISPLAY CONSOLE                |    |
| Windows.....  | 10 |
| Keypad.....   | 11 |
| E. OPERATING YOUR CYCLE                                   |    |
| Powers Up the Cycle.....                                  | 12 |
| Turn Off the Cycle.....                                   | 12 |
| Power Standby Mode.....                                   | 12 |
| Quick Start.....  | 12 |
| Entering User's Personal Information.....                 | 13 |
| F. OVERVIEW OF PROGRAMS                                   |    |
| Manual Mode.....  | 14 |
| Hill.....   | 15 |
| Random.....   | 15 |
| Int I.....  | 16 |
| WT Loss (HRC 65%) / CARDIO (HRC 80%).....                 | 16 |
| Cool Down.....  | 17 |
| Displaying Workout Data.....                              | 18 |
| G. SYSTEM DEFAULT SETTING                                 |    |
| Setting Modify.....                                       | 18 |
| Setting Weight Unit.....                                  | 19 |
| H. RANGES OF VARIOUS SETTING.....                         | 19 |
| I. MAINTAINING THE CYCLE.....                             | 20 |
| J. GUIDELINES FOR EXERCISE                                |    |
| How long should I exercise.....                           | 20 |
| How often should I exercise.....                          | 20 |
| K. TROUBLE SHOOTING                                       |    |
| If the remote control unit doesn't function properly..... | 21 |
| If the LOAD doesn't respond properly.....                 | 21 |

## **SAFETY GUIDELINES:**

Please read and follow the following safety guidelines:

- Keep this owner's manual for future use and reference.
- Read this owner's manual and follow the instructions.
- Assemble and operate the Sports Art C5150 cycle on a solid, level surface.
- Never allow children on or near the machine.
- Check the machine before every use. Make sure all parts are assembled, and all nuts and bolts are tightened. Do not use the machine if the unit is disassembled in any way.
- Keep your hands away from moving parts.
- Wear proper workout clothing. Do NOT wear loose clothing. Do not wear shoes with leather soles or high heels. Tie all long hair back.
- Don't rock the unit from side to side, and take care when mounting and dismounting the unit.
- Do not use any accessories that aren't specifically recommended by the manufacturer as these might cause injuries or cause the unit to fail.
- Work within your recommended exercise level. Do NOT work to exhaustion.
- If you feel any pain or abnormal sensations, STOP YOUR WORKOUT. Consult your physician immediately.
- Allow sufficient space on both sides of the cycle for users to mount and dismount the machine.
- If any parts fail or are defective, please stop your workout immediately and contact your authorized dealer for repairs.

## INTRODUCTION

Congratulations on purchasing one of the finest pieces of commercial grade exercise equipment in the market today, the Sports Art C5150. Constructed of high quality materials and designed for years of trouble free usage, the C5150 will be an integral part of your fitness regimen.

Before using your cycle, we recommend that you familiarize yourself with this Owner's Manual. Whether you are a first time user of a bicycle or a seasoned "pro," understanding the correct use of the equipment will enhance your ability to achieve your exercise goals safely and successfully.

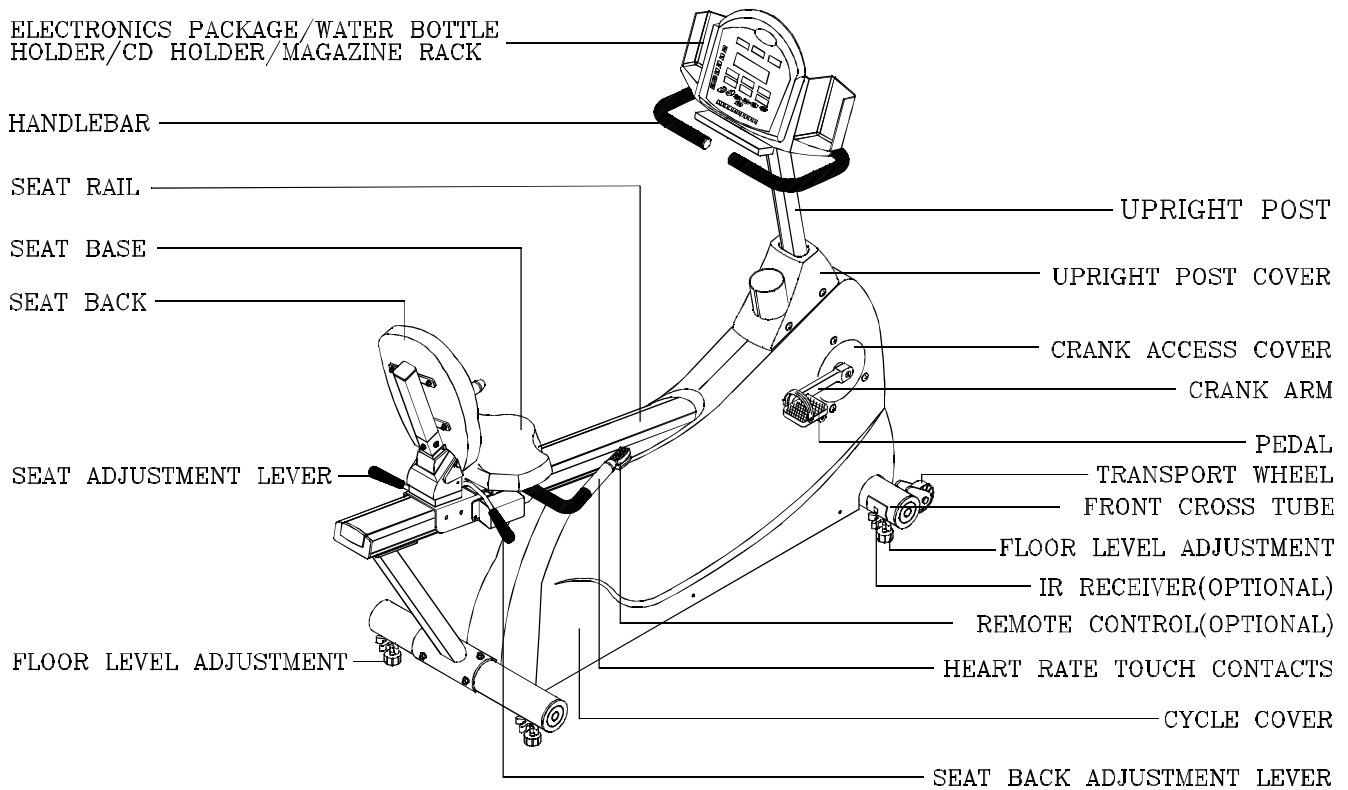



## **ASSEMBLING YOUR CYCLE**

### List Of Parts:

- . Six 5/16"x 3/4" bolts - Upright post
- . Four 5/16" wave washers - Upright post
- . Two 5/16" flat washers - Upright post
- . Four philip screws - Upright post cover
- . Four 1/4" x 1/2" bolts - Handlebar
- . Four 5/16"x 3/4" bolts - Handlebar mounting plate
- . Four 5/16" x 3/4" flat washers - Handlebar mounting plate
- . Four 5/16" spring washers - Handlebar mounting plate
- . Three 5/16" x 3/4" bolts - seat post
- . Three 5/16" flat washers - seat post
- . Four 5/16" x 3/4" bolts - seat base
- . Four 5/16" flat washers - seat base
- . One pair of foot pedals
- . Two - Way screw driver
- . One hex allen wrench
- . One open - ended wrench
- . Socket

### **Step By Step Instructions:**

Before assembling your cycle, make sure that you have all parts listed on the previous page.

The following steps explain how to assemble your Sports Art C5150. Please read every step thoroughly, and follow the directions completely to ensure correct assembly.

1. Take out the cycle frame first and make sure all packing materials are removed from the unit.
2. Place the cycle on a level, flat surface.
3. Place the upright post cover into the upright post. Locate the 16 pin cable connector inside the upright post and insert it securely into the socket.

Tighten the connector by turning both screw pins clockwise to secure. Insert the upright post to the cycle frame (see Fig.1)

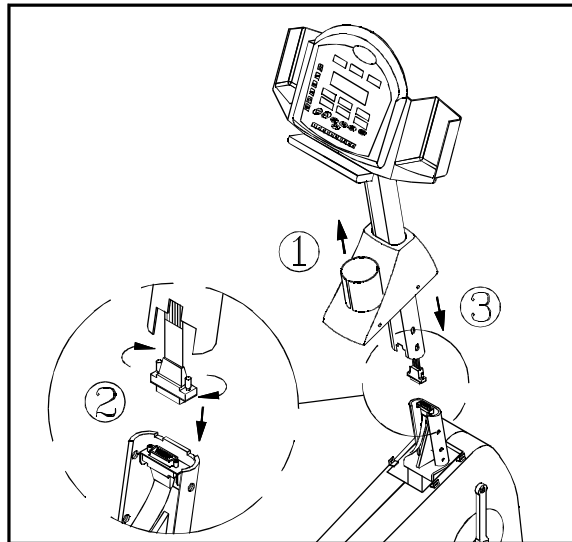

Fig.1

4. Use 6 pcs 5/16" bolts, and washers to secure the upright post (see Fig. 2).

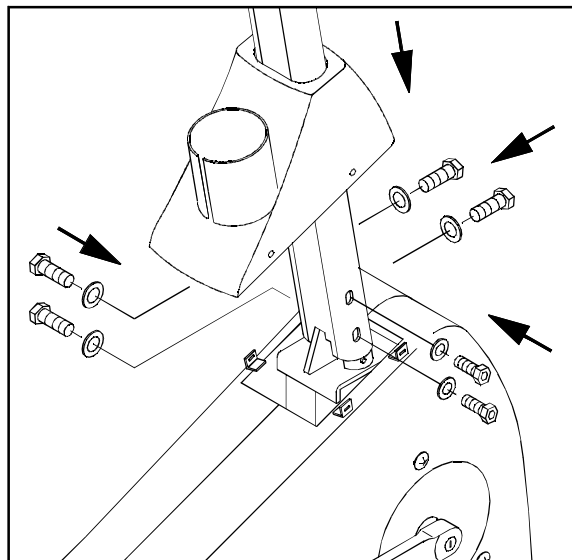

Fig.2

5. Use 4 pcs screws provided to secure the upright post cover (see Fig.3).

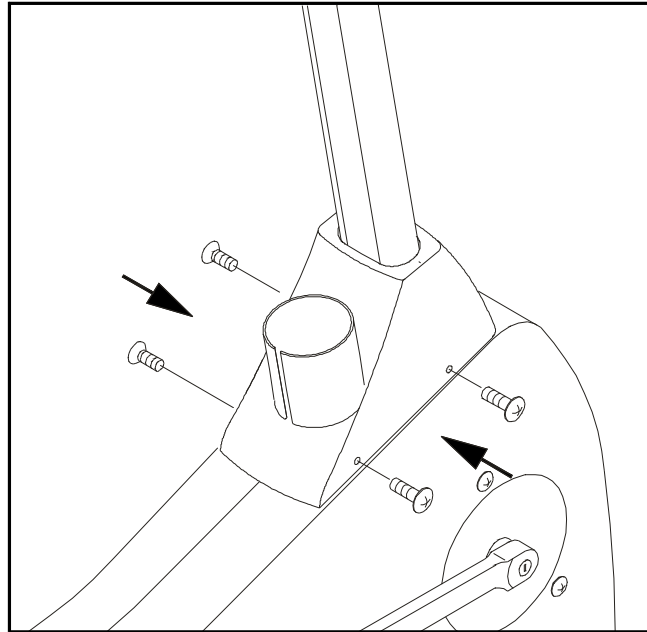

Fig.3

6. Attach the foot pedals to the crank arms on the cycle using the wrench provided. Be careful to install the pedals on the correct crank arm. A " R " or " L " on the foot pedal indicates the correct side.

Install the pedal marked " R " on the right hand crank arm ( as you stand at the rear of the cycle facing the front). When you install the pedal on the left hand crank arm, rotate the pedal counterclockwise to tighten since the pedal has left-handed screw threads (see Fig.4). Tighten the pedals securely.

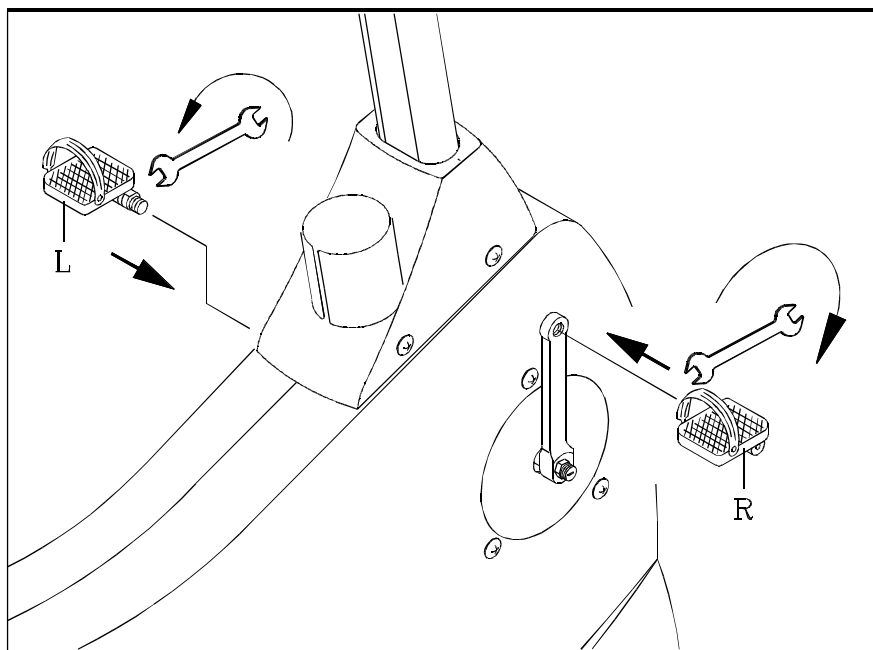

Fig.4

7. Use the 1/4" bolts to fix the handlebar to the upright post. Make sure the angle between the handlebar and the upright post is more than 90° (see Fig.5).

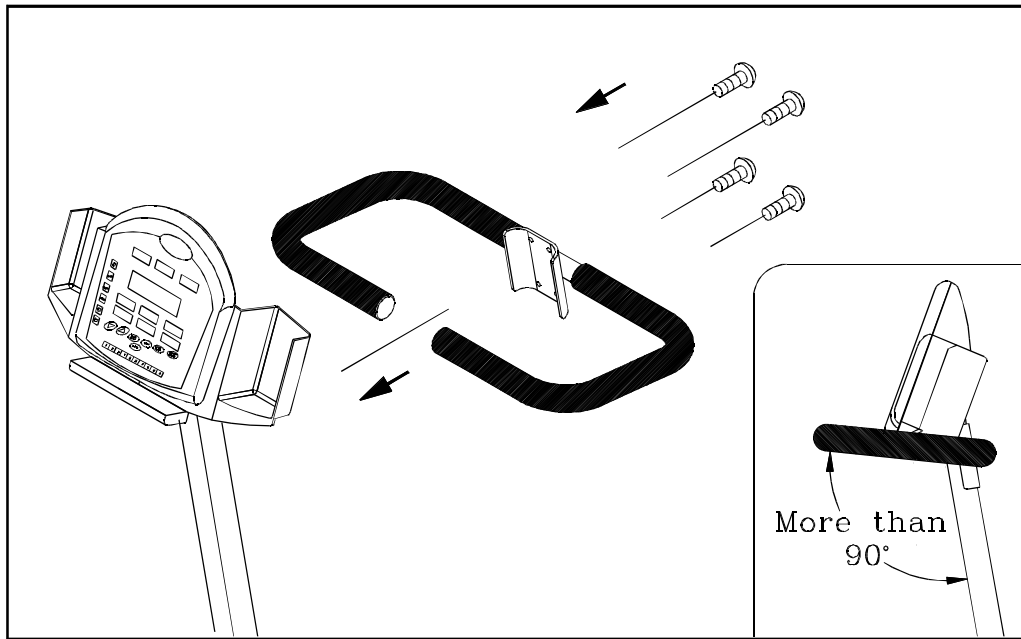

Fig.5

8. Attach the handlebar mounting plate to the cycle frame, using the bolts and washers provided. If your unit is equipped with Hand Touch Readout, connect the two wires in the right place " R " to " R " and " L " to " L " ( see Fig. 6).

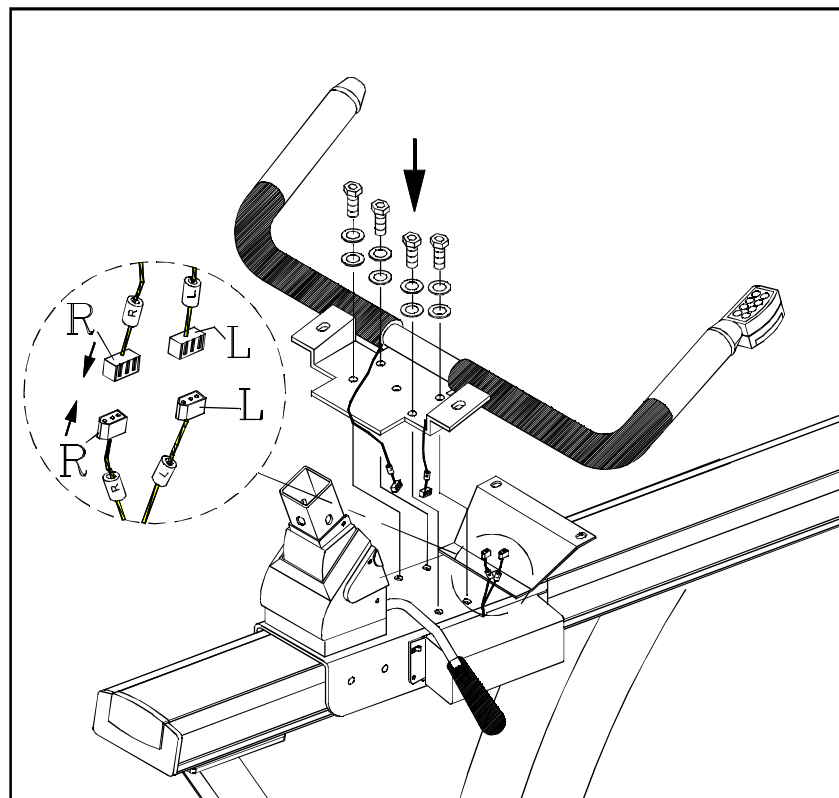

Fig.6

9. Insert the seat back into the seat post, using the 5/16" bolts and washers to secure it ( see Fig.7).

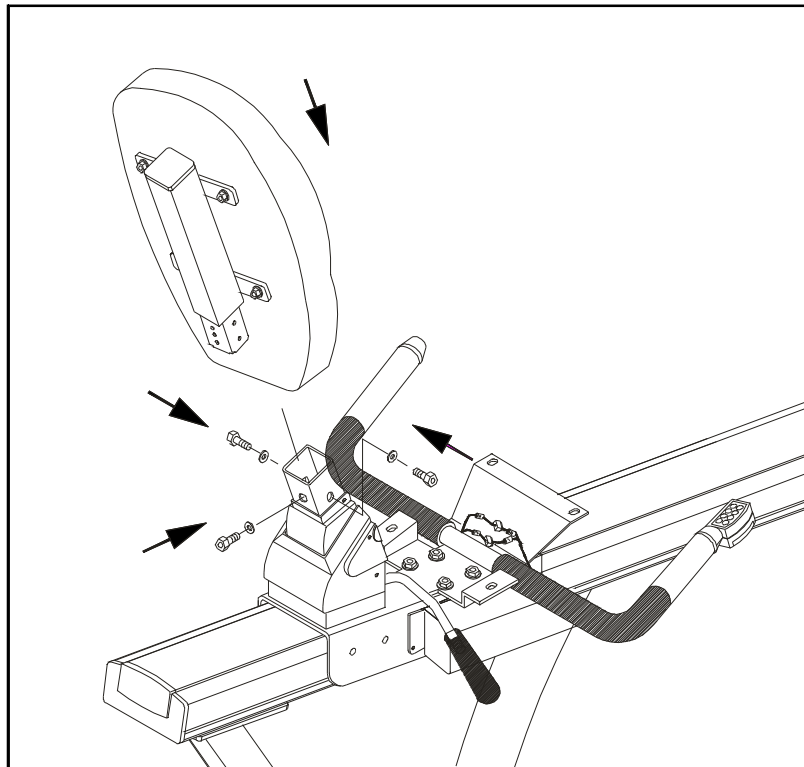

Fig.7

10. Attach the seat base to the handlebar mounting plate, using the bolts and washers provided. Insert the bolts from underneath the seat, two in back and two in front, through the handlebar mounting plate. Tighten the bolts securely (see Fig.8).

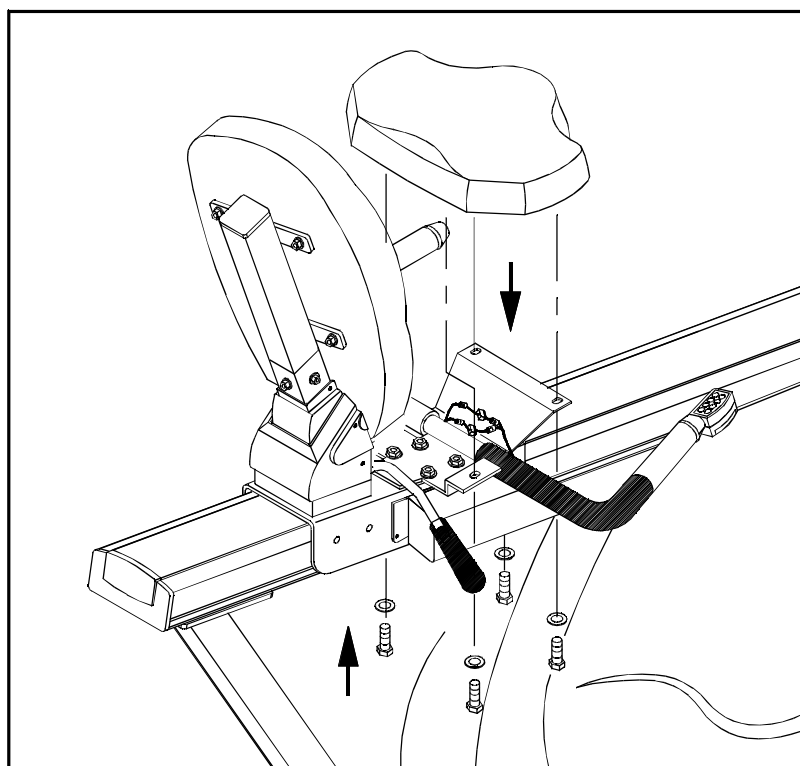

Fig.8

### Floor Level Adjustment

If the cycle is unsteady on your floor, turn the floor level adjustment either on the front or rear feet of cycle. Raise or lower the floor level adjustment to steady your cycle. Tighten the floor level adjustment by the wrench provided. (see Fig. 9)

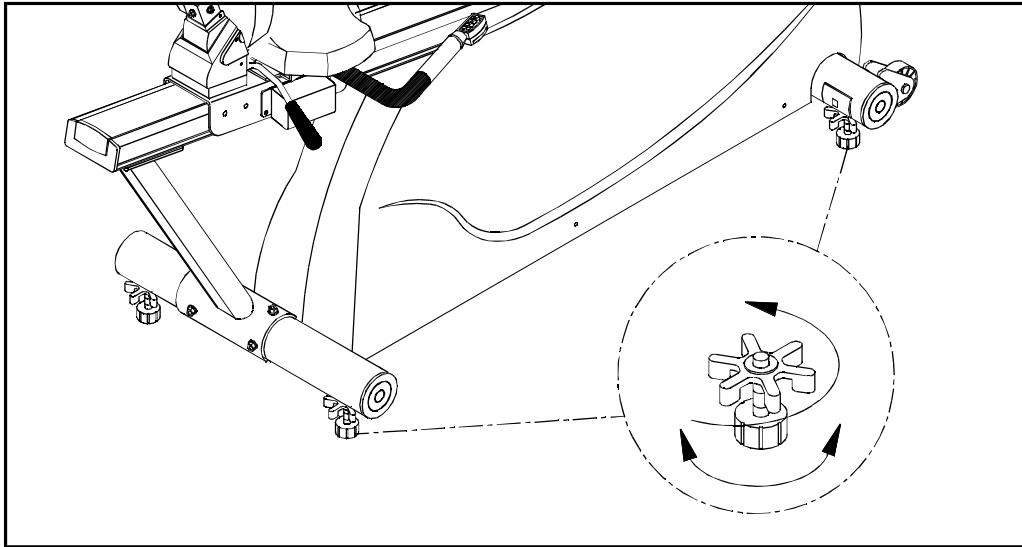

Fig.9

### Seat Adjustment

The C5150 is equipped with a two-piece seat, allowing you to adjust the seat back's angle of incline. Pull on the seat back adjustment lever and move the seat up and back to find the most comfortable position for you, then release the lever (see Fig.10).

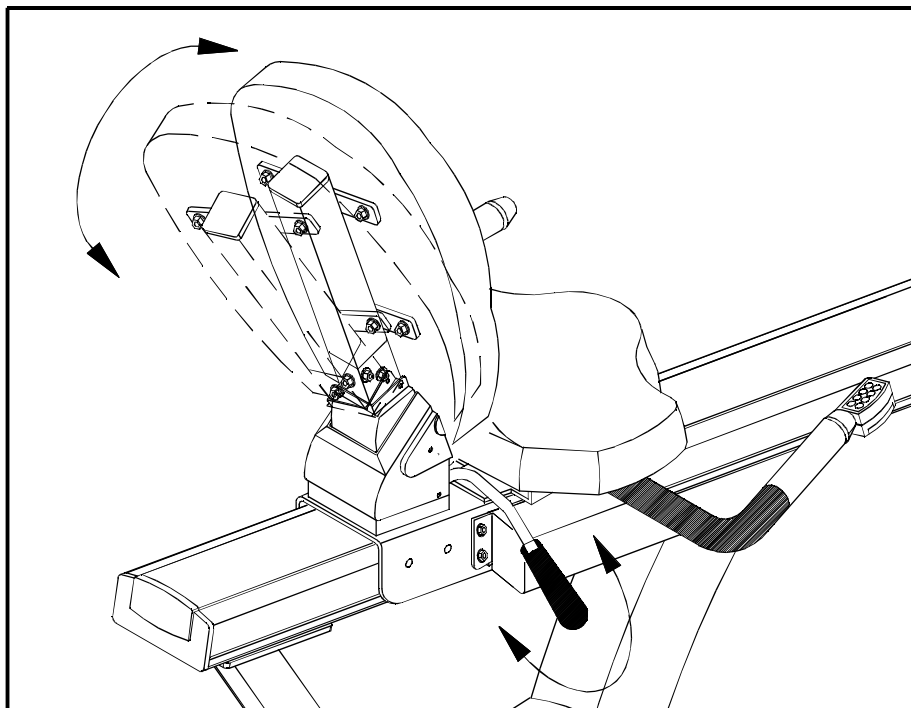

Fig.10

Before your workout, you might need to adjust the seat to the appropriate position for you. Sit on the cycle with both feet in the pedals and one leg extended as far as possible, pull up on the seat adjustment lever, and move the seat forward and backward until the pedal distance is comfortable. Release the seat adjustment lever (see Fig.11, 12).

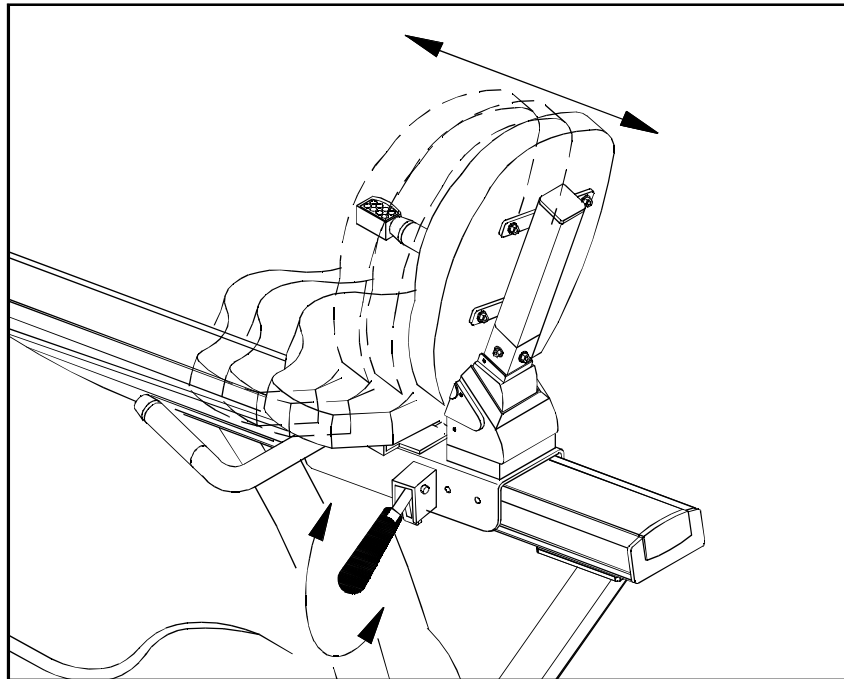

Fig.11

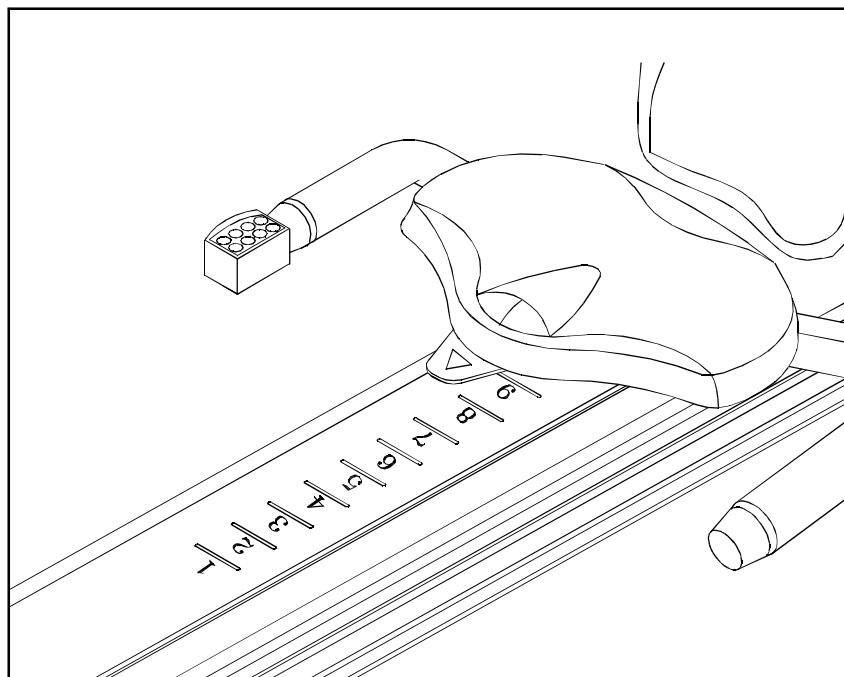

Fig.12

Your C5150 semi-recumbent cycle is assembled and ready to use.



## 1. UNDERSTANDING THE C5150 DISPLAY CONSOLE:

The new, SportsArt C5150 display console provides user-friendly control of all exercise cycle functions.

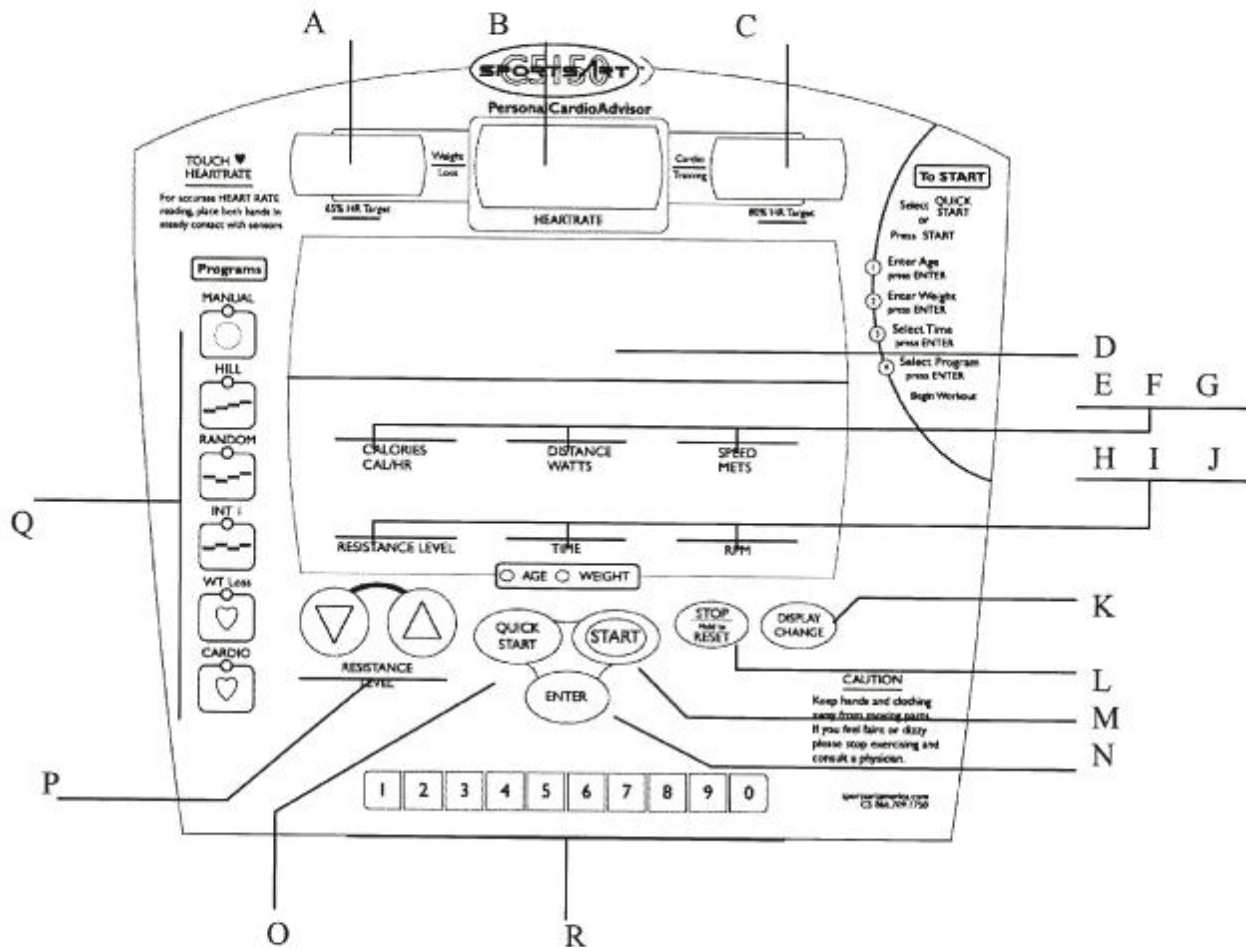

### Overview of the Display Console

#### ● Windows

A. 65% HR: The weight loss program adjusts resistance to keep the user's heart rate at 65% of the maximum heart rate. This provides the optimum weight loss workout.

B. HEART RATE: Shows the user's current heart rate.

C. 80% HR: The cardio training program adjusts resistance to keep the user's heart rate at 80% of the maximum heart rate. This provides the optimum cardio training workout.

D. DOT MATRIX window: Shows operating instruction and workout feedback.

- E. CALORIES or CAL/HR: When the CALORIES indicator is lit, this window shows the total amount of calories burnt since the beginning of the workout. When the CAL/HR indicator is lit, this window shows the average number of calories burnt per hour during this workout.
- F. DISTANCE or WATT: When the DISTANCE indicator is lit, this window shows the overall distance that would be covered by a moving bicycle during this workout. When the WATT indicator is lit, this window shows the user's workout level in watts. WATT is the unit of measurement for power output.
- G. SPEED or METs: When the SPEED indicator is lit, this window shows the user's pedaling speed per hour. When the METs indicator is lit, this window shows the user's workout level in METs (metabolic equivalents). One MET equals the consumption of oxygen per 3.5 ml/kg/min.
- H. RESISTANCE LEVEL: Shows unit resistance setting.
- I. TIME: Shows the amount of time remaining in the workout.
- J. RPM: Shows the rate that the user is pedaling in Revolutions Per Minute.

● **Keypad**

- K. DISPLAY CHANGE: Press this button to view different display modes – – toggle between CALORIES <--> CAL/HR; DISTANCE <--> WATTS; SPEED <--> METS.
- L. STOP/RESET: Press this button to stop the workout during either "PROGRAM" or "COOL DOWN" modes. Hold this button to reset the display to view the starting screen.
- M. START: Press this button to turn on display power. Also press this button while inputting personal information.
- N. ENTER: Press this button to confirm a selection.
- O. QUICK START: Press this button to start a workout without inputting user information.
- P. UP & DOWN BUTTONS: Press these buttons to input user information, or to enter workout TIME and resistance LEVEL values.
- Q. PROGRAM SELECTIONS: Select the desired workout program by pressing these buttons.

R. NUMERIC BUTTONS: Press to input personal information, or to set workout TIME and resistance LEVEL values.

## **2.OPERATING YOUR CYCLE**

### **Power Up the Cycle:**

Either press the <START> button or start pedaling to activate the unit. "C5150" will appear on the dot matrix window.

### **Turn off the Cycle:**

Automatic: To turn off the cycle, do not pedal or press any button. In two minutes, the cycle automatically shuts off.

Manual: Simultaneously press and hold RESISTANCE LEVEL <▼> + <ENTER> buttons for one second to shut off the cycle.

Please note that user personal information settings are erased once the cycle is turned off. (For User's Personal Information, please see page).

### **Power Standby Mode:**

When the user has stopped pedaling and no display buttons have been pressed for over 30 seconds, the cycle enters automatic standby mode. The dot matrix window shows the pattern below.

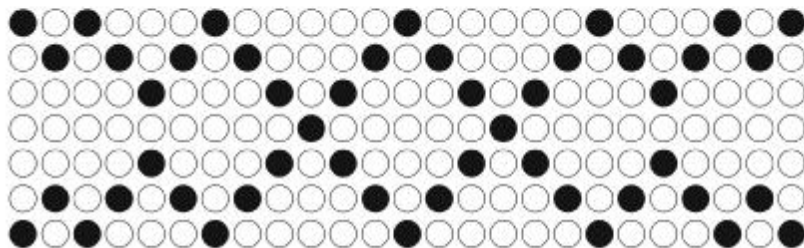

\*Pedal or press <START> to return to the starting screen.

### **Quick Start:**

- Press the "QUICK START" button on the console to start exercising without first inputting user information. The TIME value in the TIME window will start counting up. Press the "STOP/RESET" button if you do not want the time value to accrue.
- To operate a PROGRAM after a <QUICK START> workout has begun, press the <STOP/RESET> button to return to the starting screen, then press the button for the desired PROGRAM. Set the workout time, then press the <ENTER> button to begin the workout.



## Entering User's Personal Information:

Press the <START> button after turning on unit power. The display prompts the user to input personal information. Follow the prompts.

### 1. Setting Age

Press the <START> button. The dot matrix window prompts the user to "ENTER AGE" and "AGE" appears. The TIME window shows "35". The AGE indicator lights up.

- Use either <▲><▼> button or numeric buttons to set user age, then press the <ENTER> button.
- If user age is not entered properly, the dot matrix window shows "AGE". (The age value range is 12 to 99.)
- After entering age, corresponding 65% and 80% target heart rates appear in the Personal Cardio Advisor part of the display.

### 2. Setting Weight

After age is set, the dot matrix window prompts the user to "ENTER WEIGHT" and "WT" appears. The TIME window shows either "165" if the unit is preset in lbs, or "75" if preset in kilos. The WEIGHT indicator under the TIME window lights up.

- Use either <▲><▼> button or numeric buttons to set user weight; then press the <ENTER> button.
- If user weight is not entered properly, the dot matrix window shows "WEIGHT". (The weight value range is 20 to 150 Kgs or 50 to 330 Lbs). "WRONG NUMBER" scrolls across the display if the entry exceeds the weight range.

### 3. Setting Time

"ENTER TIME" scrolls across the dot matrix window, then "TIME" appears. The time value appears as "30:00".

- Use either <▲><▼> button or numeric buttons to set workout time; then press the <ENTER> button.
- If the exercise time value is not entered properly, "WRONG NUMBER" scrolls across the dot matrix window. The minimum time setting is 5 minutes. (The time value range is 05:00 to 99:00.)

## 4. Setting Program

After the workout time is set, "SELECT PROGRAM" scrolls across the dot matrix window.

- All Program indicators on the left side of the display console illuminate. Press the desired program button to activate the program.
- The time value counts down when the user starts to pedal. If the user does not pedal, "PEDAL TO START" scrolls across the dot matrix window.
- When the program counts down to zero, COOL DOWN mode is activated. (For information on the COOL DOWN mode, please refer to.)

## 3. OVERVIEW OF PROGRAMS

### A. Manual Mode:

- Once the manual mode program is selected, the dot matrix window displays the following:

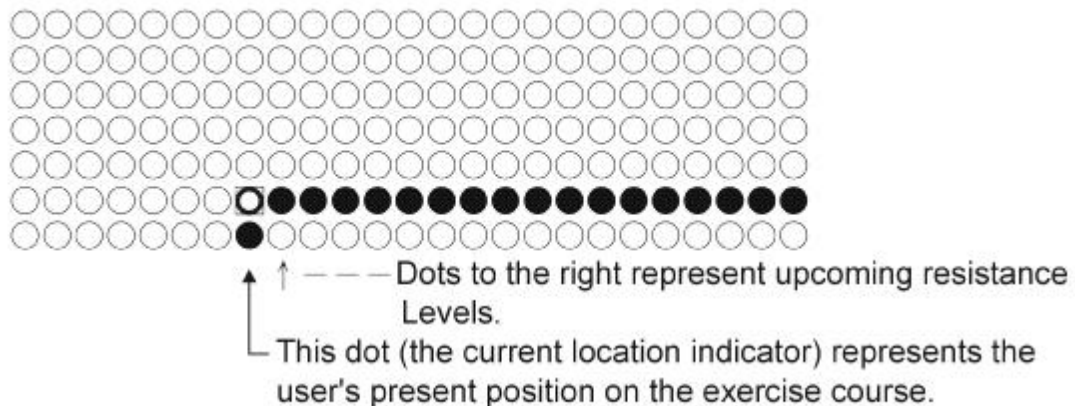

- Resistance LEVEL can be adjusted at any time during the workout. Simply press numeric buttons or <▲> <▼> to adjust resistance.
- The LEVEL indicator illuminates and beeps when level values are input correctly. In contrast, the LEVEL indicator illuminates and returns to the original setting when values are input incorrectly.
- The current location indicator illuminates when the user pedals but extinguishes once the user stops pedaling.
- Resetting the time value is not allowed during a workout.

## B. HILL

- There are three different workout patterns in the HILL program. Press the <HILL> button to select the desired workout pattern: HILL 1 → HILL 2 → HILL 3. The dot matrix window displays the pattern of the selected workout. An example follows.

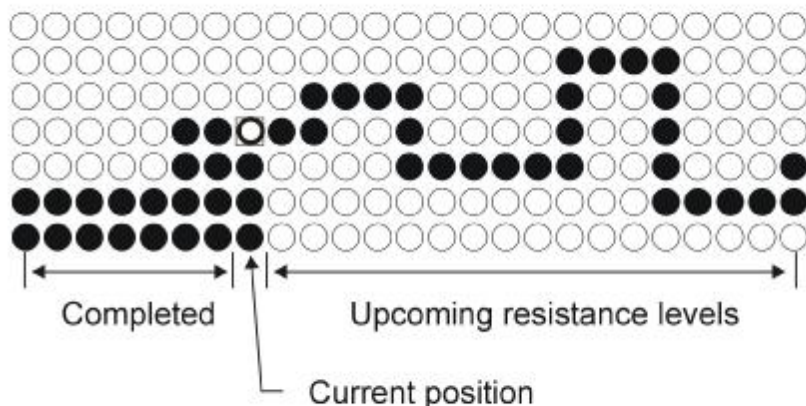

- The level can be adjusted at any time during a workout.

## C. RANDOM

- Countless combinations of workout patterns exist within the RANDOM program. Resistance can also be adjusted during a workout, but the adjustments apply only to the present location on the workout pattern.

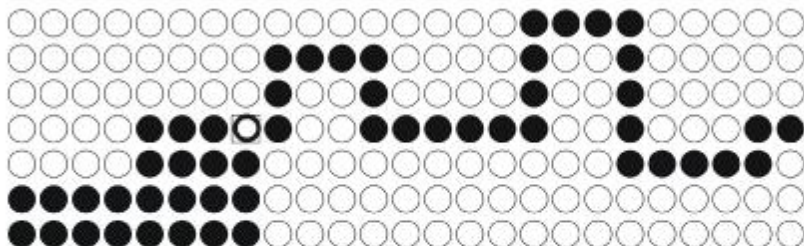

- If the <RANDOM> key is pressed again during a workout, a new workout pattern is activated.



## D. INT I

- INT I is a workout distinguished by two segments. Each segment lasts one minute.

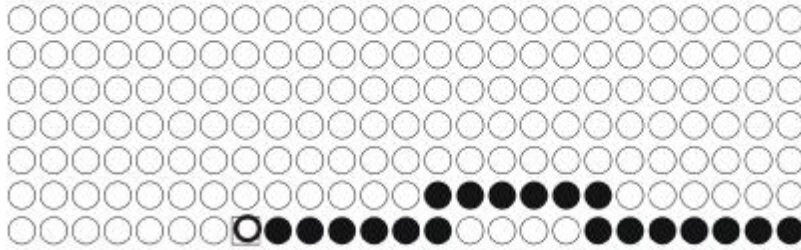

- The resistance LEVEL is adjusted individually for each segment. For instance, if resistance is set at LEVEL 10 on Segment 1, this setting applies to each Segment 1 during the entire workout. The same situation applies to Segment 2. However, resistance can be adjusted any time during the workout. In this case, the resistance adjustment applies to that entire segment throughout the workout.
- The resistance is automatically determined by the display if no resistance setting is made at the beginning of the workout. (Resistance levels range from 1 ~ 20.)
- Before going to the next segment, "GOING TO LEVEL XX" scrolls across the dot matrix window. The display beeps once, and the LEVEL window illuminates.

## E. WT Loss ( HRC 65% ) / CARDIO ( HRC 80% )

The cycle will not have this function as follows if it is not equipped with HRC feature.

HRC – The Heart Rate Control function actually includes two different workouts – a weight loss (WT Loss) workout and a cardio workout. The weight loss program keeps the user's heart rate at 65% of maximum to provide an optimal weight loss workout. The cardio workout keeps the user's heart rate at 85% of maximum to provide an optimal cardio workout. The POLAR transmitter belt must be worn for either of these programs to operate. Press the WT Loss or CARDIO key to activate the desired heart rate control program. If the user's personal information was not entered at the beginning of the workout, age must be entered to calculate the target heart rate, and <ENTER> must be pressed to confirm the age value. (Please refer to page.13 for Entering User's Personal Information.) Follow the prompts.

- "MODIFY YOUR HEART RATE LIMIT" scrolls in the dot matrix window, then "MDFY" appears. Use either <▲><▼> buttons or numeric buttons to set the desired heart rate limit, then press <ENTER> to confirm your choice and start your workout. The heart rate limit modification prompt will not appear if the system default setting is "NO". (For system default settings, please refer to page.18).



- The beginning resistance LEVEL is 5 at an RPM of 50. If the user pedals at less than 50 RPM, "SPEED UP" scrolls across the dot matrix window.
- Heart Rate Control function operates only after the user's heart rate rises to the target heart rate. At this time, the display beeps and the words "HEART RATE CONTROL STARTING" scroll across the dot matrix window. Once the Heart Rate Control is activated, the resistance LEVEL adjusts automatically to achieve an optimal heart rate workout.
- A POLAR transmitter belt must be worn properly during the whole workout for heart rate control to operate. If the transmitter slips or no belt is worn, a message "NO HEART RATE READING, PLEASE CHECK TRANSMITTER" scrolls across the dot matrix window.
- An example of a heart rate display of 104 beats per minute appears below.

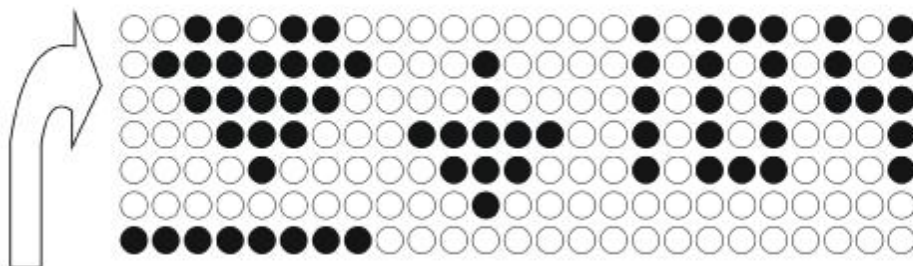

The heart sign will flash when the pulse signal has been detected.

## F. COOL DOWN

When a workout ends, the unit automatically enters COOL DOWN mode, which lowers workout intensity. The COOL DOWN time is 5 minutes.

- After a beep sound, "TOTAL TIME + AVERAGE HR" appears once on the dot matrix window. The TIME window shows total workout time. The HEART RATE window shows average heart rate during workout. The CALORIES window shows total calories burnt, and DISTANCE window shows total distance traveled.
  - Before entering COOL DOWN mode, "GOING TO COOL DOWN" appears once in the dot matrix window. The display automatically switches to MAN'L mode.
  - The resistance decreases one LEVEL every 10 seconds until LEVEL 1 is reached, after which, resistance can be adjusted.
- Press the <STOP/RESET> button to terminate COOL DOWN mode.

- When COOL DOWN mode is terminated, "SELECT PROGRAMS OR PRESS START" appears in the dot matrix window. Simply press the desired PROGRAM to continue the workout, or press <START> to alter personal user information, and then press the <ENTER> button before selecting any new workout.

### G. Displaying Workout Data

- To display workout data, press the <STOP/RESET> button any time during a workout. The dot matrix window shows the prompt "STOP". The display console shows workout data as follows:

|                 |                          |
|-----------------|--------------------------|
| HEART RATE      | : average heart rate     |
| DOT MATRIX      | : "C5150"                |
| SPEED/DISTANCE  | : total workout distance |
| CALORIES/CAL HR | : total calories burnt   |
| TIME            | : total workout time     |

- Pressing the <STOP/RESET> button terminates a workout program. A new workout program can then be selected. But previous workout data is retained. "SELECT PROGRAMS OR PRESS START" scrolls across the dot matrix window. Simply press the desired PROGRAM for a new workout, or press the <START> button to alter Personal User Information, and then press the <ENTER> button before selecting a new workout.

## 4. SYSTEM DEFAULT SETTING

At the starting screen, where the display shows "C5150", press LEVEL <▲> + LEVEL <▼> buttons simultaneously to enter the system default setting. (To enter the starting screen, press the <RESET> button.)

### 1. SETTING MODIFY:

- 1.1 The pre-setting of the SETTING MODIFY mode is Number
- 1.2 Once in the default setting, "PRESS ▼▲ TO SELECT MODIFY HRC TARGET HR, PRESS ENTER" scrolls across the dot matrix window and "MDFY" appears.
- 1.3 The HEART RATE window shows either "NO" or "YES". Press the <▲> or <▼> button to modify the default setting. Then press "ENTER" to confirm your choice.
- 1.4 Press the <RESET> button to leave the default setting unchanged and return to the starting screen.

## 2. SETTING WEIGHT UNIT

(This setting does not apply to cycles sold in the U.S.A. as they are preset in LB). The weight unit can be switched from LB to KG units. After "PRESS ▼▲TO SELECT LB/KG" scrolls across the dot matrix window, the previous weight setting appears. Press either <▲> or <▼> to choose the desired weight unit. Press <ENTER> to confirm your choice, or press <STOP/RESET> to leave the default setting and to return to the starting screen.

## 5.RANGES OF VARIOUS SETTINGS :

Display:

LEVEL : 1 to 20. Maximum resistance: LEVEL 20.  
TIME : 00:00 ~ 99:59.  
DISTANCE : 0.01 ~ 99.99 Mile  
                  0.1 ~ 999.9 KM  
RPM : 0 ~ 250 Real Value  
WATTS : 0.0 ~ 9999  
METS : 0.0 ~ 40.0  
SPEED : 0.0 ~ 99.9 Mile/hr or Km/hr  
CALORIES : 0.0 ~9999  
CAL/HR : 000 ~ 9999 °

Setting:

LEVEL : 1 to 20  
TIME : 05:00 ~ 99:00 (minute)  
AGE : 12~ 99  
WEIGHT : 20 ~ 150 Kg or 50 ~ 330 LB

## **MAINTAINING THE CYCLE C5150**

The Sports Art C5150 requires little maintenance. The C5150's smooth operation is dependent on keeping the unit as clean as possible.

Regular cleaning is recommended to keep your cycle C5150 at peak performance. Before your workout, use a dry cloth to clean the surface of the electronics package.

**NOTE: NEVER POUR LIQUIDS ON THE ELECTRONICS PACKAGE.**

To clean the plastic parts, use a mild detergent and make sure the unit is completely dry before operating.

It is recommended that you keep all liquids away from the unit during operation. Spillage of liquids onto or into the machine will void the warranty.

## **GUIDELINES FOR EXERCISE**

How long should I exercise?

The duration of your exercise session is dependent on your fitness level. In general, it is recommended that you maintain your heart rate in the training zone for at least 10 minutes to realize an aerobic benefit. As your fitness level increases, you will be able to maintain your heart rate in the training zone for longer periods: usually between 20 and 30 minutes.

When starting your workout, use the first several minutes to warm up, then slowly increase your workload to bring your heart rate into your specific training zone. At the end of your workout, gradually decrease your workload, then exercise lightly as a "cool down".

How often should I exercise?

Aerobic exercises, to achieve the greatest benefits, should be performed 3-5 times a week. It is important to allow sufficient time, at least 24 hours, for your body to recover after exercise.

## **TROUBLE SHOOTING:**

If the REMOTE CONTROL UNIT doesn't function properly:

- 1 . Replace the two AAA 1.5V (4M-4) batteries (see Fig. 16-17).

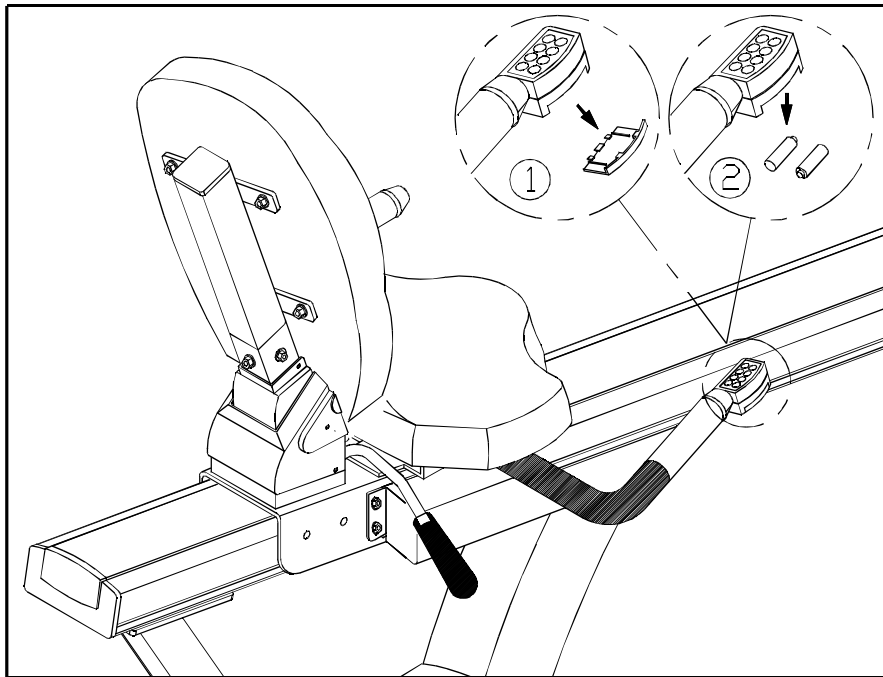

Fig.16

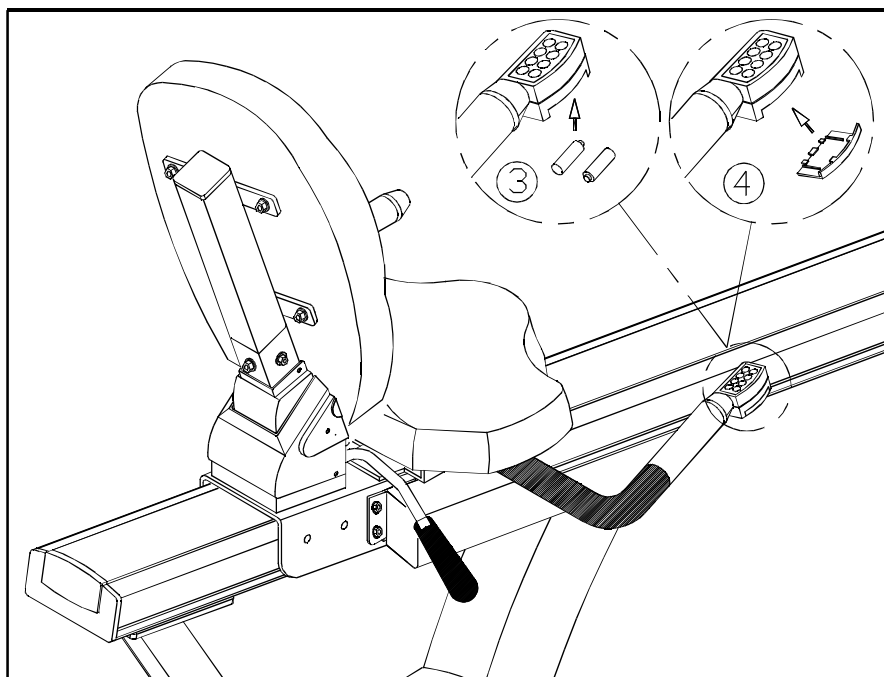

Fig.17

2. If the unit still doesn't function properly after replacing the batteries, please contact your authorized Sports Art dealer.

## **IF THE LOAD DOES NOT RESPOND PROPERLY :**

If there is no load or the load does not respond properly when you set the LEVEL, please contact your authorized Sports Art dealer for further details.

Wiring Schematic:

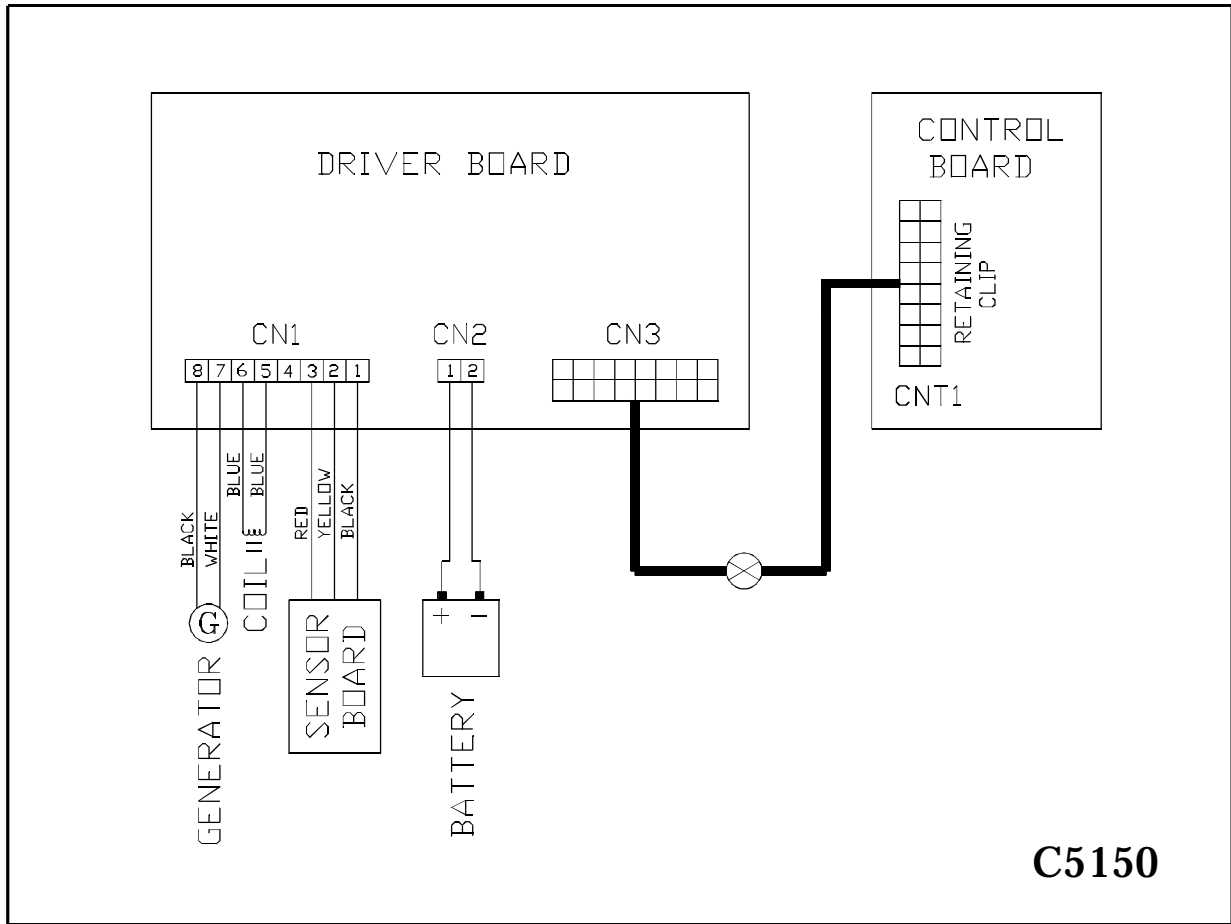

**Your Authorized Sports Art Distributor**