

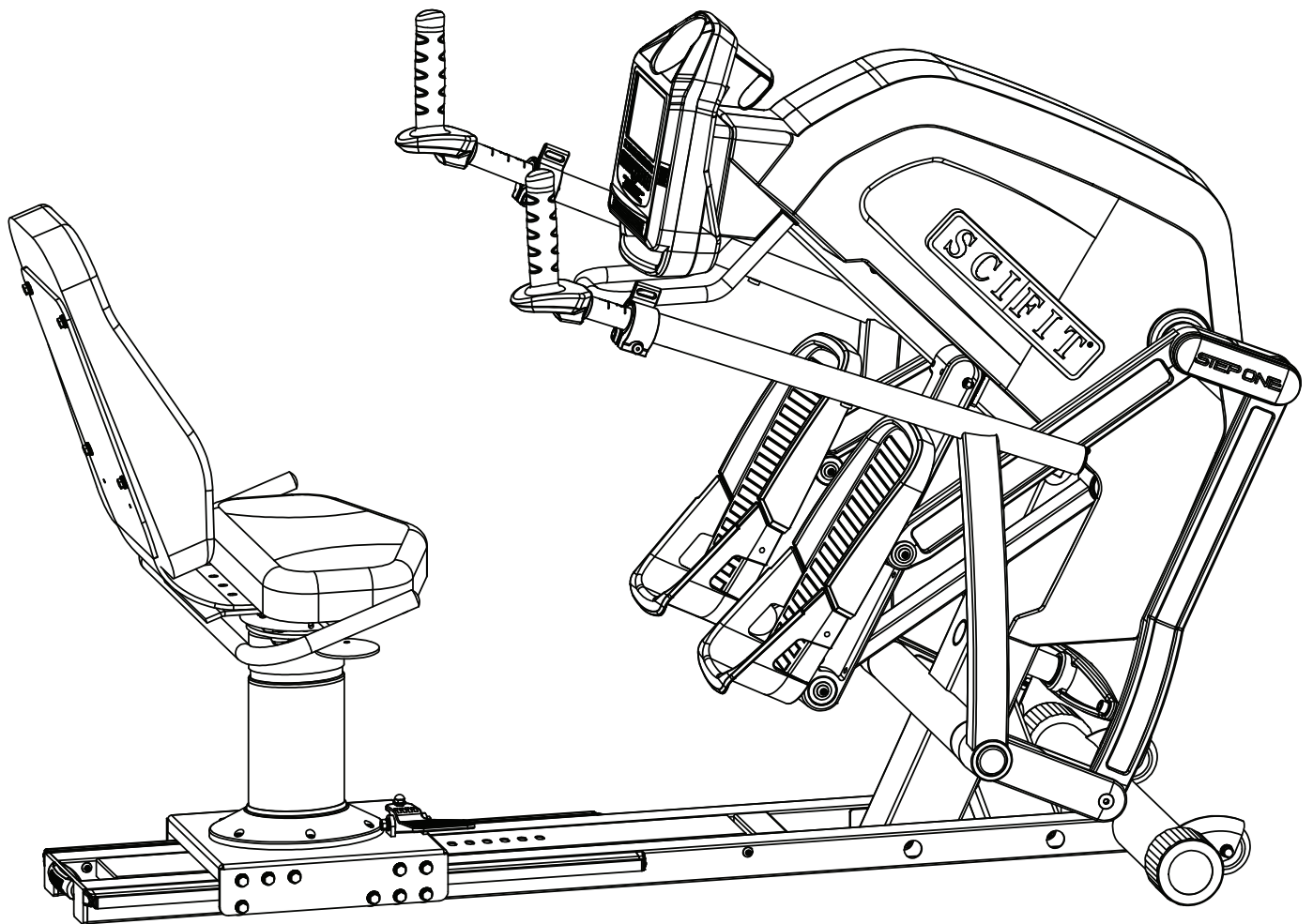



Scientific Solutions For Fitness™

Owner's Touchscreen Operation Manual

STEP ONE™



RECUMBENT STEPPER

 Before Using this product, read this manual and follow all safety rules and operating instructions. 

THIS PAGE LEFT BLANK INTENTIONALLY

TABLE OF CONTENTS

SAFETY INFORMATION	1
INTRODUCTION	2
SPECIFICATIONS	3
SET-UP & INSTALLATION	4
PRODUCT OVERVIEW	5
KEYPAD FUNCTIONS	6
HANDLEBAR & SEAT ADJUSTMENTS	7 - 11
HEART RATE TRANSMITTER STRAP	12
PROGRAM INSTRUCTIONS	13 - 20
ADDITIONAL KEY FEATURES	21
MAINTENANCE & SERVICE	22
WARRANTY	23 - 27
CERTIFICATIONS	28
WARRANTY CARD	29

SAFETY INFORMATION

The purpose of safety symbols is to attract your attention to possible dangers. The safety or attention symbols and their explanations deserve your careful attention and understanding. The warnings do not, by themselves, eliminate any danger. The instructions or warnings they give are not substitutes for proper accident prevention measures.

Look for these symbols to point out safety precautions or important information.

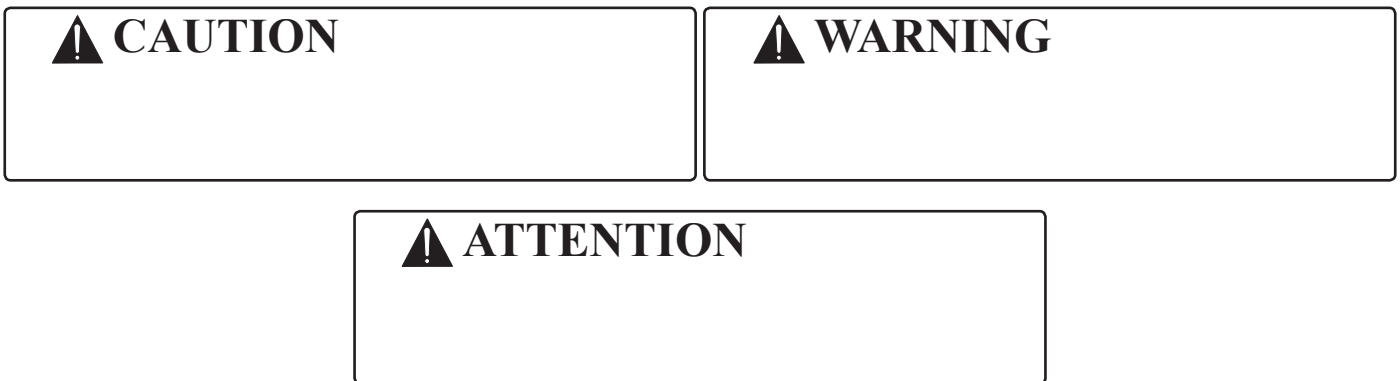

Read all instructions before using your SCIFIT exercise machine. Save these instructions for future reference.

Close supervision is necessary when the exercise machine is being used by or near children or individuals with disabilities. Keep children away from extended hand and foot supports.

Use the exercise machine only for its intended use as described in this manual. Do not use attachments not recommended by the manufacturer.

Never drop or insert any object into any opening.

Do not use outdoors or in a harsh environment where water is present (i.e. pool or spa areas).

INTRODUCTION

Thank you for your purchase of the SCIFIT StepOne recumbent stepper. We have incorporated the finest technology and ergonomic design into this machine to assist you in achieving your fitness goals. However, for your safety, please adhere to the following recommendations before you begin to exercise.

The SCIFIT StepOne is designed for Class “S” (Commercial), Class “A” (High Accuracy) and Class “II a” (Medical Device Directive) applications. The intended uses are for Cardio & Pulmonary Rehabilitation as well as Sports Medicine, Physical Therapy, Physical Conditioning and Strength Training. SCIFIT equipment is suitable for placement in medical, wellness, fitness, and recreational facilities. The StepOne recumbent stepper has 200 levels of console controlled resistance, which ensures that users of all fitness levels will be able to get a challenging but not overwhelming workout.

Consult Your Physician

Consult your physician or medical specialist before participating in any exercise program, especially if you are pregnant or if you are suffering from heart disease, respiratory disease, diabetes, hypertension, high blood pressure, elevated cholesterol, arthritis, or any other diseases and physical complaints.

Adult Usage

SCIFIT equipment is designed and intended for adult usage and children of appropriate ages while being supervised. Young children should be kept a safe distance away from equipment.

Cool Down

To prevent muscle injuries and soreness, you should always cool down (at least 5 minutes) by doing a series of stretches after each workout.

CAUTION

Always stretch after a workout session to reduce the risk of personal injury. Failure to stretch properly may result in injury to yourself.

Guidelines for Healthy Adults

The American College of Sports Medicine (ACSM) and the American Heart Association (AHA) are continuously updating guidelines and recommendations for physical activity.

The current basic recommendations from ACSM and AHA are:

Do moderately intense cardio 30 minutes a day, five days a week.

OR

Do vigorously intense cardio 20 minutes a day, three days a week.

AND

Do eight to ten strength-training exercises, eight to twelve repetitions of each exercise twice a week.

Moderate-intensity physical activity means working hard enough to raise your heart rate and break a sweat, yet still being able to carry on a conversation. It should be noted that to lose weight or maintain weight loss, 60 to 90 minutes of physical activity may be necessary. The 30 minute recommendation is for the average healthy adult to maintain health and reduce the risk for chronic disease.

To review the latest guidelines and recommendations, visit the American College of Sports Medicine website: www.acsm.org

WARNING

Stop exercising immediately if you feel nausea, dizziness, sharp pain, or any other physical discomfort. Failure to stop exercising can result in injury or death to yourself.

Train Intelligently

To ensure a future of good health, you should always eat well balanced meals, drink plenty of fluid/water during a workout, and stay fit by exercising intelligently. Always follow training guidelines that are specific to your own physical condition.

WARNING

Injuries to health may result from incorrect or excessive training. Failure to stop exercising can result in injury or death to yourself.

SPECIFICATIONS

Weight**StepOne** - 275 lbs (124 kg)

Max User Weight **Fixed/Swivel** - 450 lbs (204 kg) **Fixed Bariatric**- 600 lbs (272 kg) **Adjustable** - 450 lbs (204 kg)

PowerSelf generating w/auto recharge battery back-up (15 Volt AC adapter included).

Resistance SystemElectromagnetic Self Generating Resistance

ProgramsManual, Fit Quik, Constant Workout, ISO-Strength, 7 Pre-programmed HILLS profiles, Heart Rate, Stress Test and Random

Accuracy ClassClass A

WarrantyWithin U.S. & Canada: 5 years parts, 1 year labor
Outside U.S.: 5 years parts, no labor

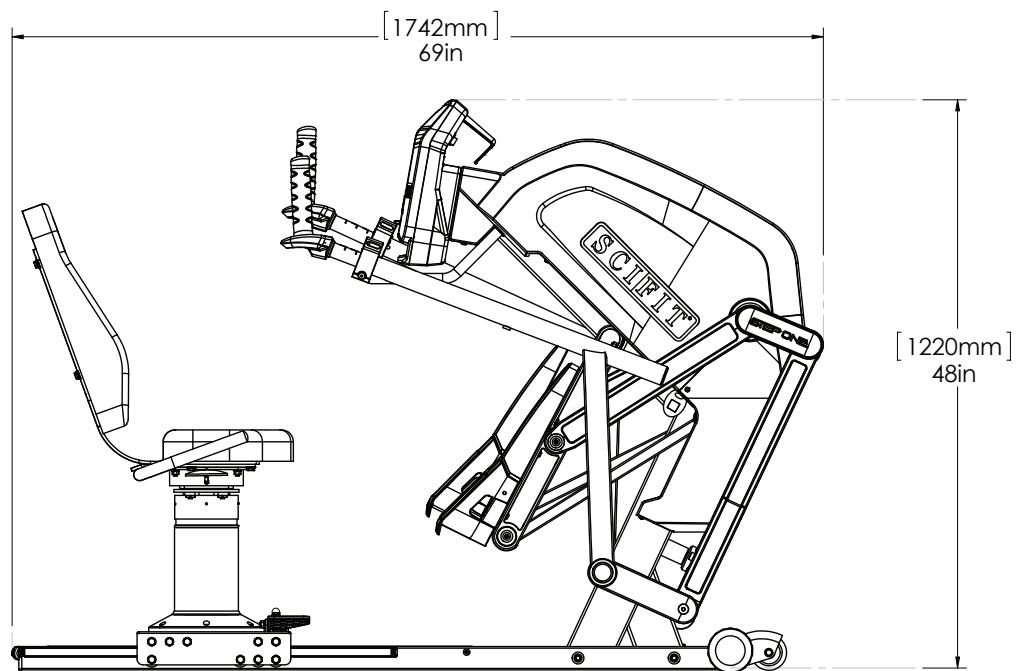
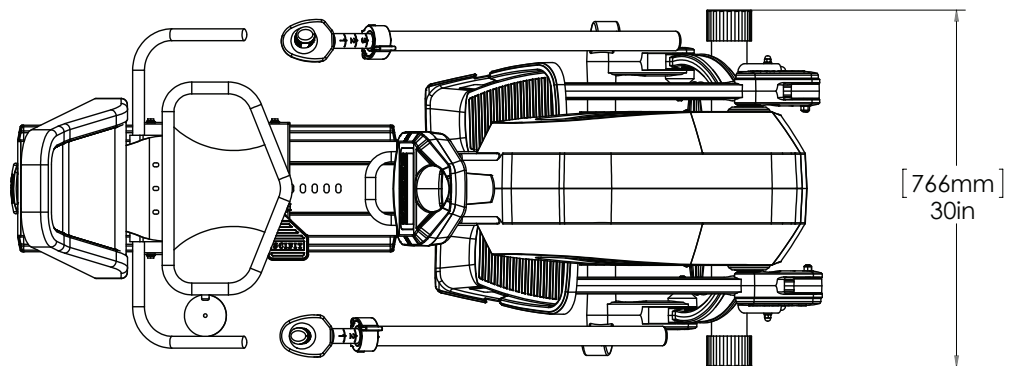

SETUP & INSTALLATION



ATTENTION

Depending on the regular operation of the machine, the StepOne may require the DC wall pack to be plugged into the machine at all times.

The following guidelines show typical conditions that would require use of the DC wall pack with shorter stride rates requiring more steps per minute:

1. A full step stride of 11.5" below 40 Steps per Min.
2. A half step stride of 6" below 80 Step per Minute



CAUTION

Additional personnel may be required to move the machine. Placement on an unstable sub-floor without a proper safety perimeter can result in injury to yourself and others.

Placement of Cardiovascular Machine

The StepOne has two transport wheels located in the front of the machine and can be moved by grabbing the lift handle at the rear of the machine.

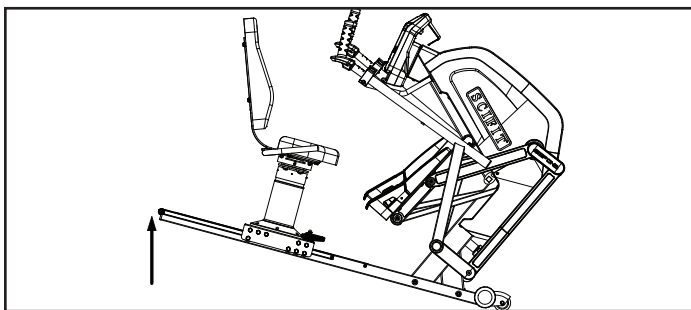
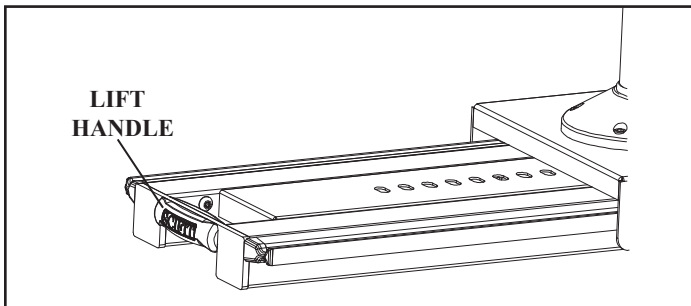

Position the unit in a location that has a stable and level sub-floor. Equipment should be positioned in a location that is not in direct sunlight, extreme temperatures and humidity or where it may be splashed with water or fluids.

This machine is intended for indoor use only.

Level Cardiovascular Machine

If the sub-floor is unlevel, the unit is equipped with leveling end caps. The end caps are designed with the recess of the end cap off centered. This allows you to rotate the endcap(s) to a position that will level the equipment. After adjustment, check and make sure end caps are fully seated against base frame tubes.

Offset Endcap

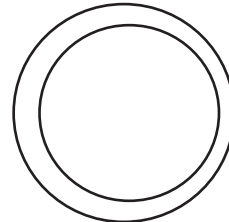

The StepOne should be positioned with a safety perimeter of 40" or 1 meter around the unit (see diagram).

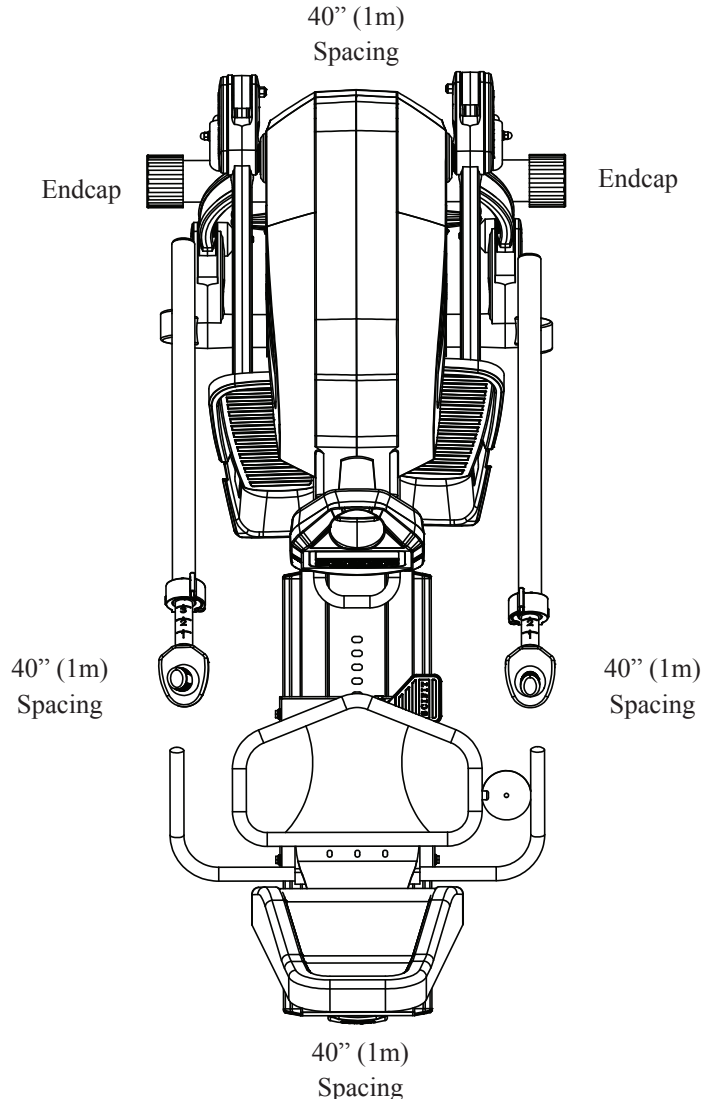

PRODUCT OVERVIEW

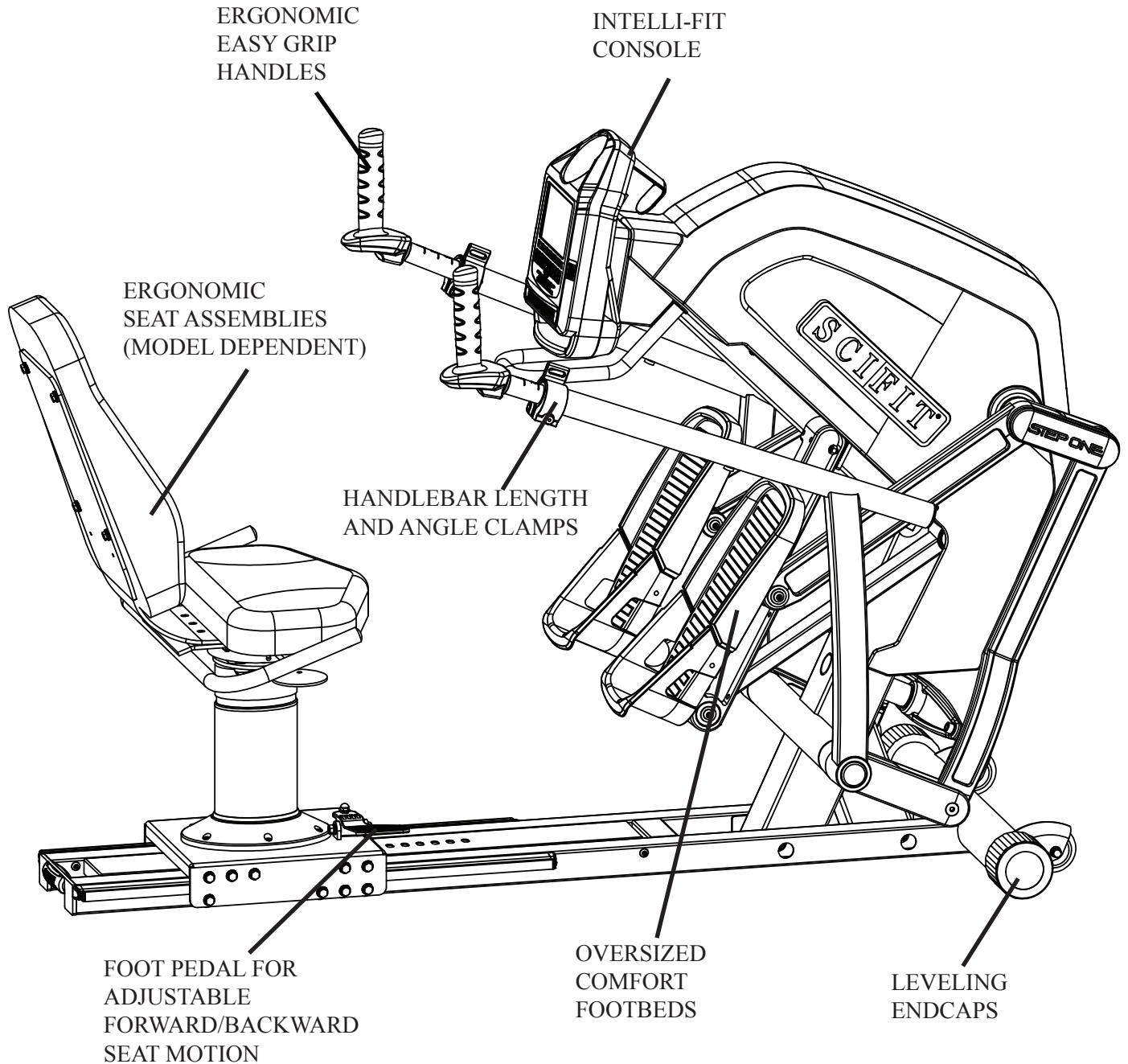

KEYPAD FUNCTIONS

⚠ ATTENTION

The tactile keys on the membrane switch are fully functional and may still be used for Data Entry, Workout selection, etc., if so chosen.

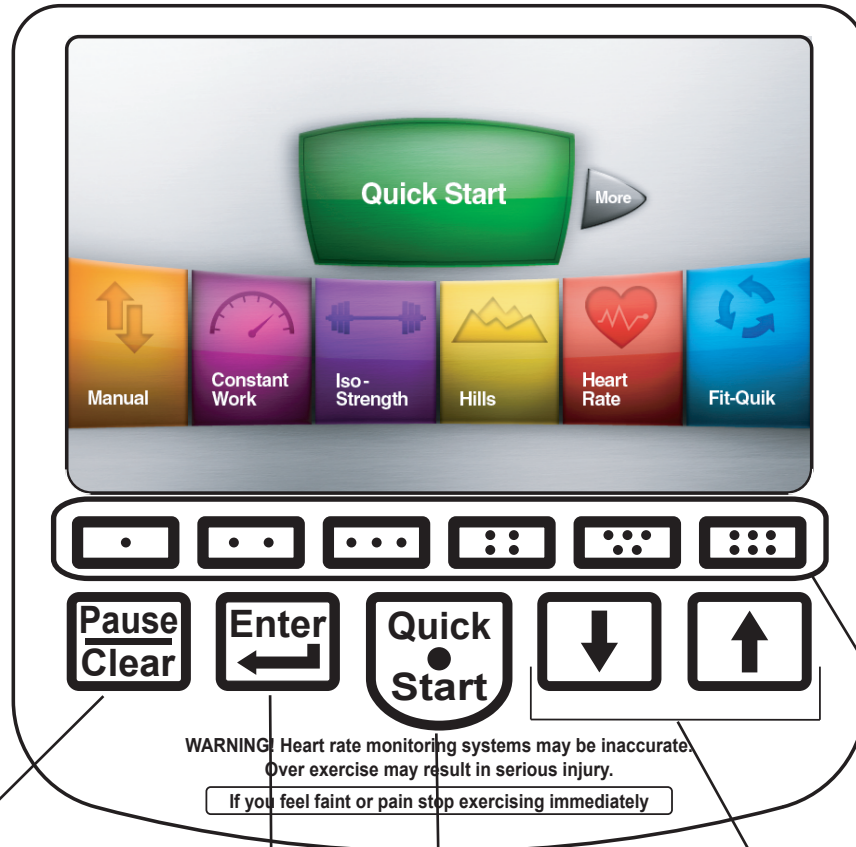

WORKOUT SELECTION
The operator can choose up to eight different workouts.

PAUSE/CLEAR
This key pauses the workout at anytime. Three choices then become available:
1. Continue the workout
2. Change data entry information
3. Stop the workout

QUICK START
Begins a pre-programmed 15 minute workout session.

UP/DOWN ARROWS
These keys increase or decrease values of workout parameters.

ENTER
This key confirms the operator's category value selection in the data entry screen.

HANDLEBAR & SEAT ADJUSTMENTS

Handlebar Adjustments

The right and left handlebars of the StepOne can be adjusted into different positions with the attached clamping mechanism, so the operator can place themselves into the proper biomechanical position for a comfortable workout.

Repositioning The Handlebar

Gently grab the handle of the clamping mechanism and pull downward freeing the handlebar to move away from the machine or toward the machine. Using the etched numbers on the handlebar determine the most comfortable position for your arm length.

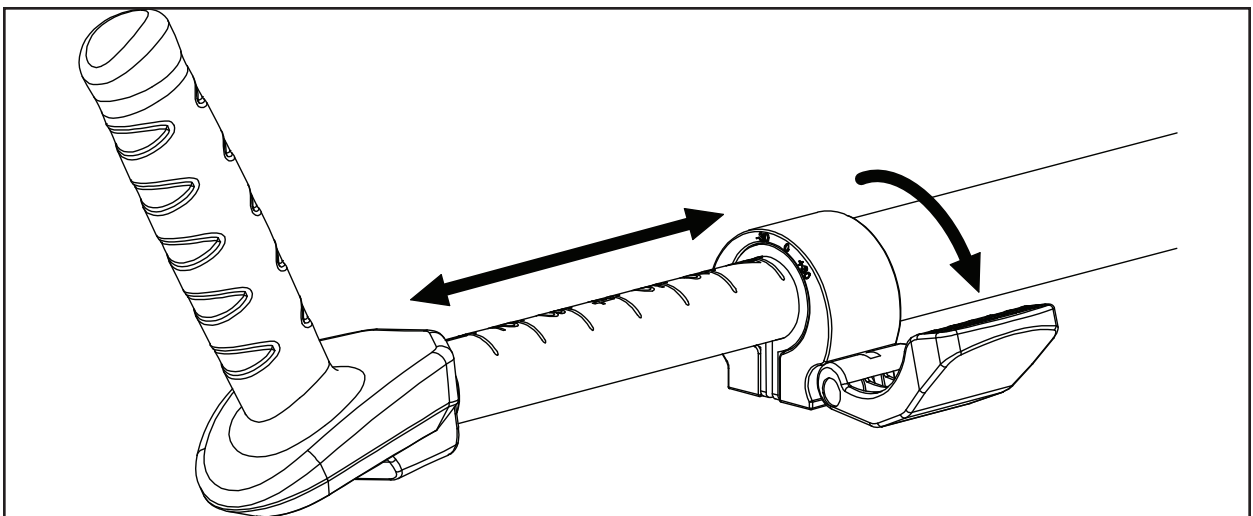

When the desired position has been determined, lock the handlebar in place by pushing upward on the clamp handle until it is firmly against the body of the clamp mechanism.

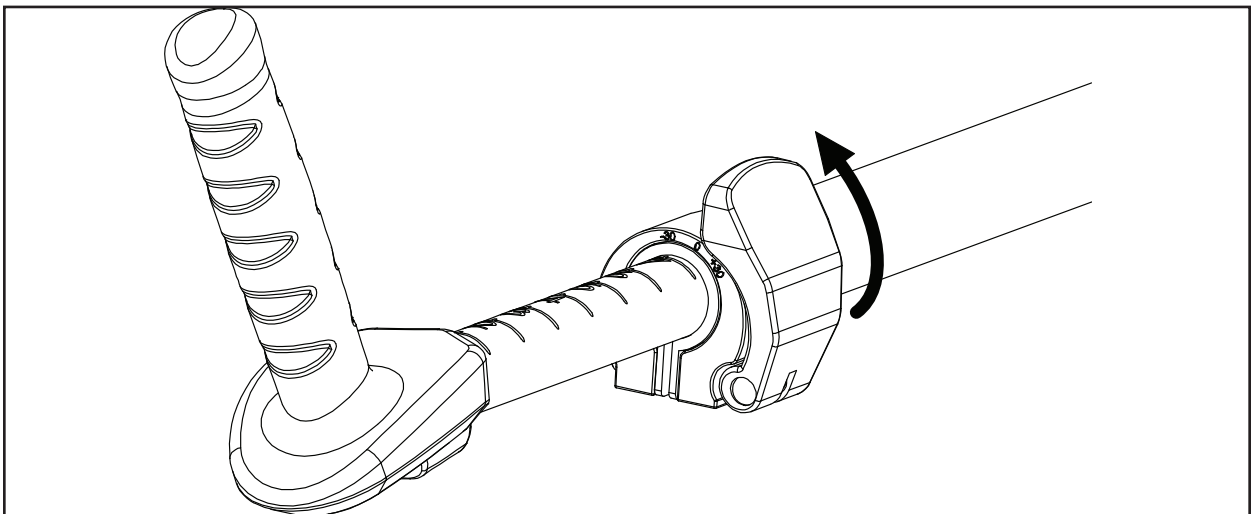

HANDLEBAR & SEAT ADJUSTMENTS

Handlebar Angle Adjustments

The handle can also be positioned into three different angles to allow the operator's hand a more ergonomic and comfortable setting during the workout.

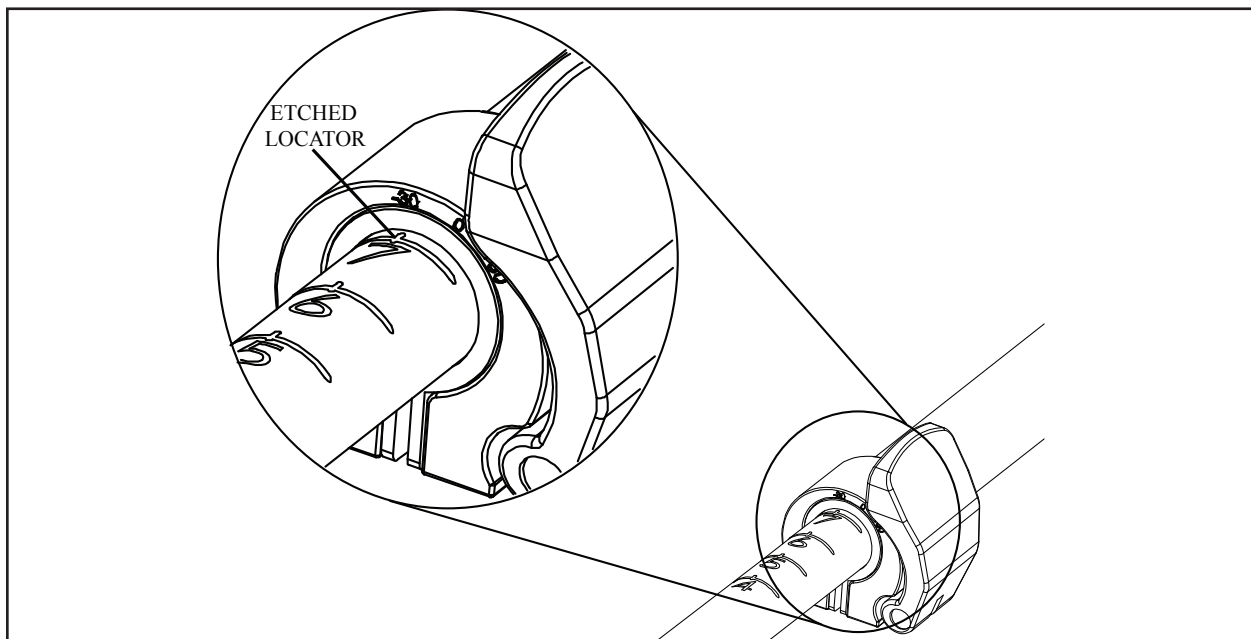
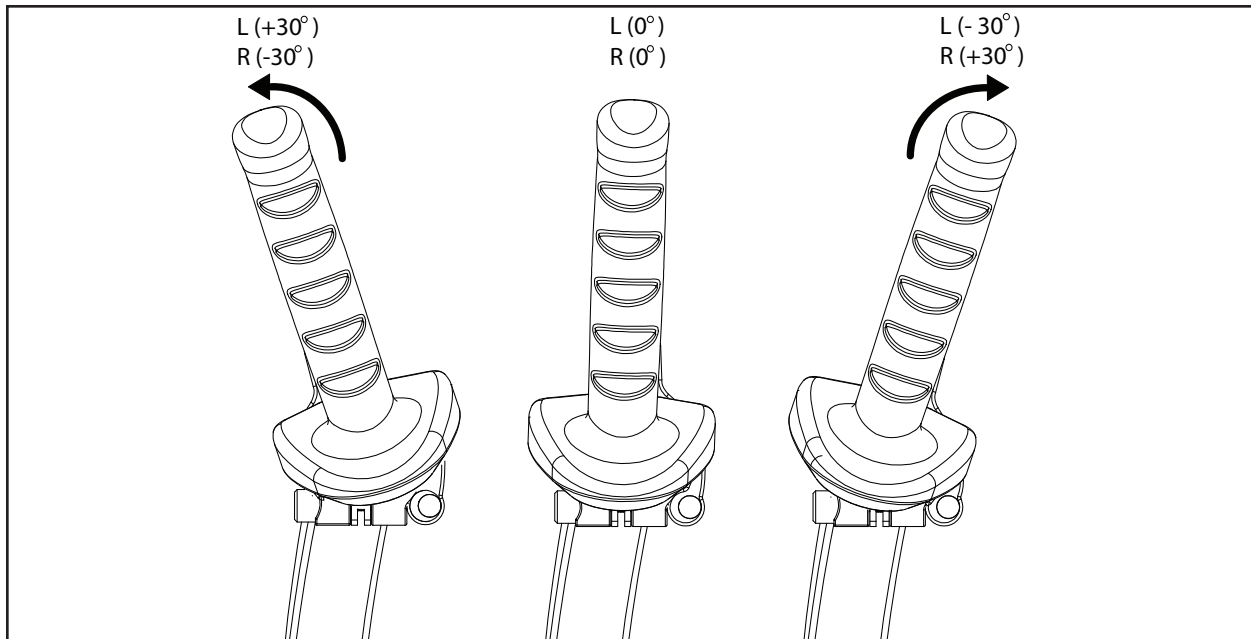

Step 1: Open the clamp to free the handle.

Step 2: Use the etched notch on the handle to position the handle at the preferred angle.

Step 3: Close the clamp to secure the angle position.

HANDLEBAR & SEAT ADJUSTMENTS

FIXED SEATPOST

SEAT REMOVAL

Step 1: Place one hand on the back of the seat cushion back support.

Step 2: Use the other hand to pull upward and hold the yellow adjustment knob located on the front of the seatpost.

Step 3: Slide the seat assembly backwards until it is completely off of the machine seat track.

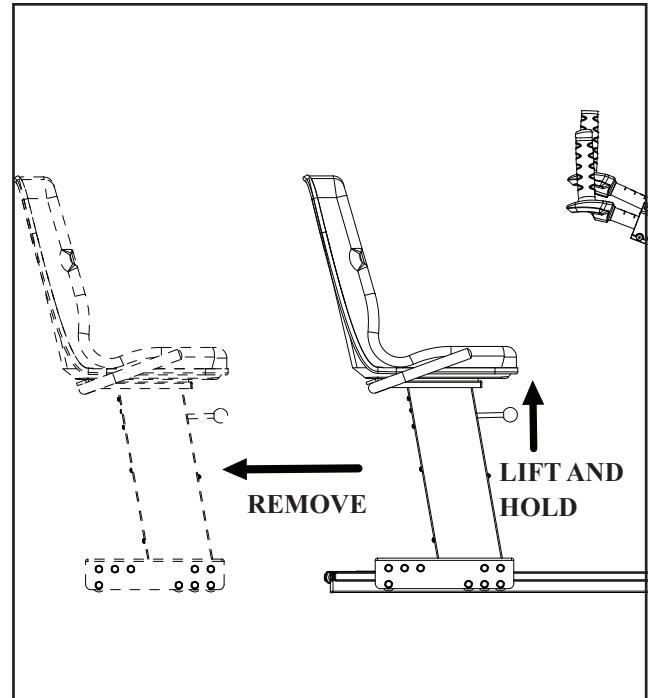

FORWARD/BACKWARD ADJUSTMENT

The seat can be adjusted in 1" (25.4mm) increments and is held in place with a spring loaded pin. This is done by using the round yellow knob at the front of the seat assembly.

Step 1: Place one hand on the back of the seat cushion back support.

Step 2: Use the other hand to pull upward and hold the yellow adjustment knob located on the front of the seatpost.

Step 3: Slide the seat assembly forward or backwards on the machine seat track to the desired position.

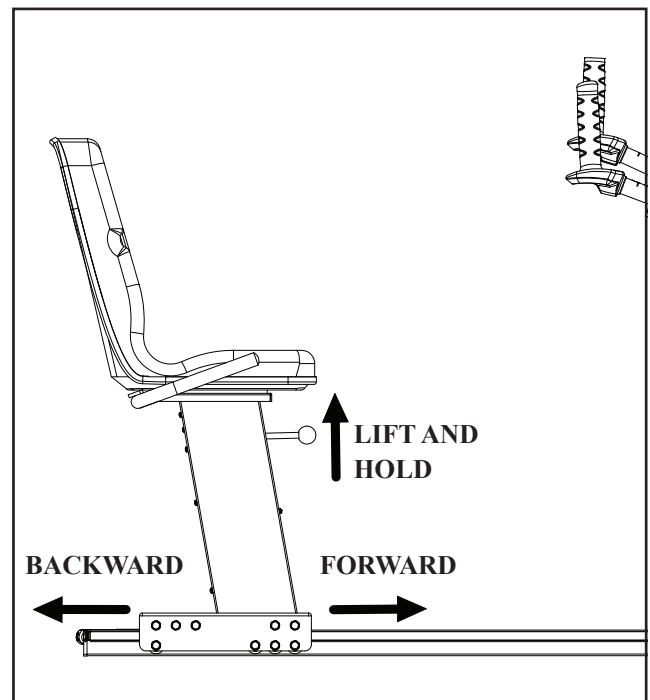

HANDLEBAR & SEAT ADJUSTMENTS

ADJUSTABLE & FIXED/SWIVEL SEATPOSTS

SEAT REMOVAL

Step 1: Place one hand on the back of the seat cushion back support.

Step 2a (Adjustable Only): Use the other hand to pull upward and hold the yellow T-Handle located in front of the seat.

Step 2b (Fixed/Swivel): Step on the yellow foot pedal.

Step 3: Slide the seat assembly backwards until it is completely off of the machine seat track.

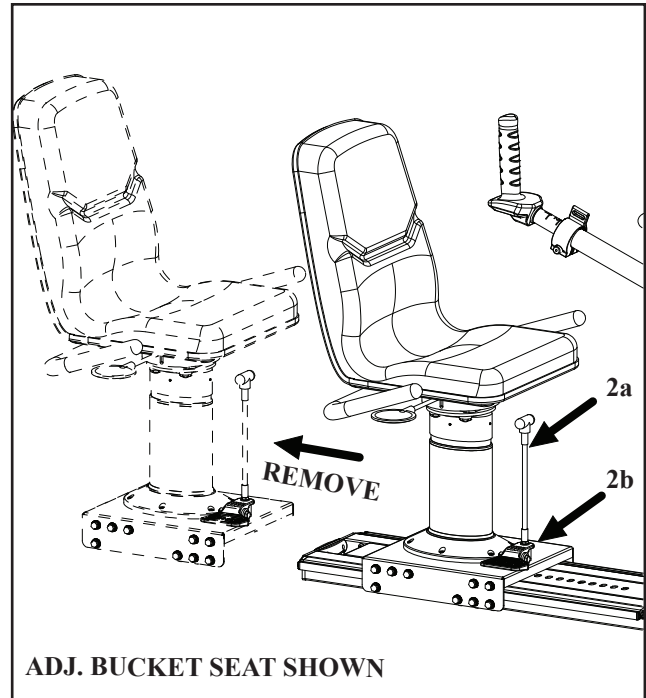

FORWARD/BACKWARD ADJUSTMENT

The seat can be adjusted in 1" (25.4mm) increments and is held in place with a spring loaded pin. This is done by using one of two options (1) Pull cable or (2) Foot pedal.

Step 1: Place one hand on the back of the seat cushion back support.

Step 2 Option #1 (Adjustable Only): Use the other hand to pull upward and hold the yellow T-Handle located in front of the seat.

Step 2 Option #2 (Adjustable, Fixed/Swivel) Step on the yellow foot pedal

Step 3: Slide the seat assembly forward or backwards on the machine seat track to the desired position.

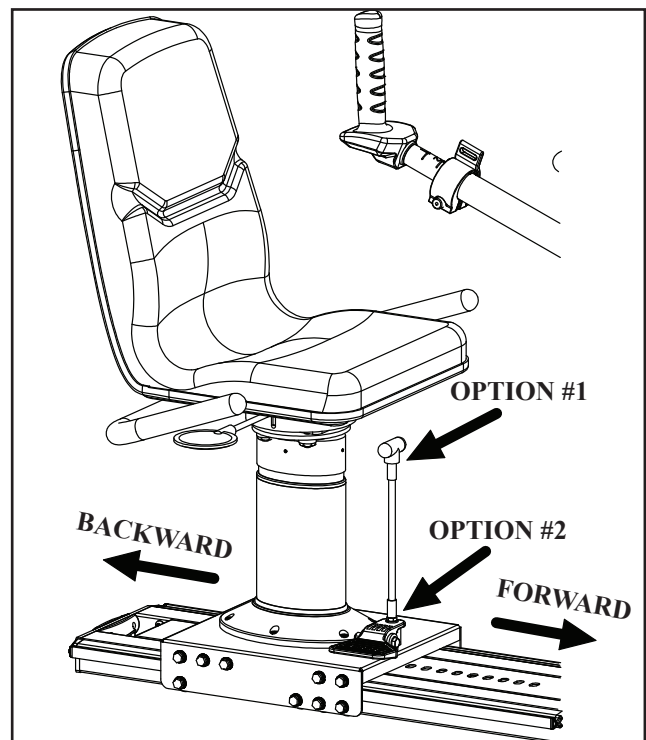

HANDLEBAR & SEAT ADJUSTMENTS

ADJUSTABLE & FIXED/SWIVEL SEATPOSTS

SEAT ROTATION

Step 1: Push downward on the yellow handle adjustment lever to rotate the seat right or left.

Note: The seat will lock into place every 90 degree position.

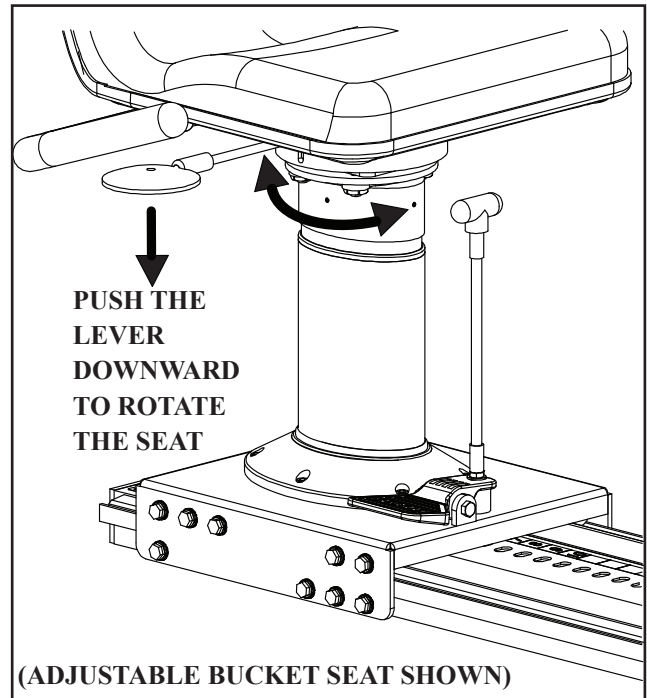

VERTICAL ADJUSTMENT (ADJUSTABLE SEATPOST ONLY)

Step 1: Pull the yellow handle lever upward to raise or lower the seat assembly.

Note: No weight should be on the seat when raising.

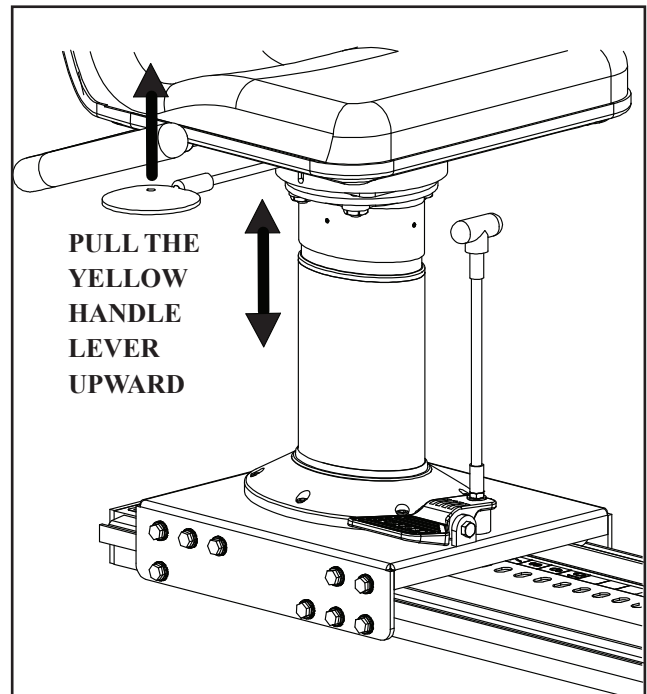

HEART RATE TRANSMITTER STRAP

Heart Rate Transmitter Strap

The optional wireless heart rate transmitter accessory is a useful device if you desire continuous feedback on your current heart rate during a workout. In addition, the StepOne includes a heart rate control program which requires the use of the strap.

The heart rate control program enables the user to set-up a target heart rate through real-time monitoring of the user's heart rate. The console maintains the user's heart rate at or below this established target rate by decreasing the workload if the user's heart rate exceeds the target.

Activating & Deactivating Transmitter

Heart Rate transmitter straps come in a variety of styles and manufacturers. To properly activate, secure the strap to the chest and to deactivate follow the instructions that come with the transmitter strap.

Calculating Target Heart Rate Zone

Your approximate Maximum Heart Rate (MHR) is equal to 220 minus your age. The upper limit of your target zone is equal to 0.85 times your MHR. The lower limit of your target zone is equal to 0.60 times your MHR.

For Example:

Your age is 40:

$$220 - 40 = 180$$

$$180 \times .85 = 153 \text{ (max MHR)}$$

$$180 \times .60 = 108 \text{ (min MHR)}$$

These values are based upon averages, always consult your physician to establish the proper Heart rate zone for your individual health condition.

CAUTION

Always follow the manufacturers instructions for proper care and use. Failure to follow manufacturers instructions may result in injury to yourself.



WARNING

Heart Rate monitoring systems may be inaccurate if you feel faint. Stop exercising immediately. Excessive exercising may result in serious injury or death.

PROGRAM INSTRUCTIONS

Programs

SCIFIT products have 200 levels of computer controlled resistance, which ensures that users of all fitness levels will be able to get a challenging but not overwhelming workout. Because the resistance is adjustable in .1 increments, it is easy for the user to track progress. SCIFIT products feature one of the highest resistance capabilities available on any cardio equipment.

The StepOne is self-generated and has an extremely low starting resistance. One pedal movement activates the console and the screen will remain lit at the most minimal levels of movement.

The StepOne has a battery back up which will keep the screen lit for a short period after the workout is completed or if the user stops. This varies between 0 seconds and 3 minutes and can change with the amount of use each product gets.

If you prefer the console to remain lit at all times, a AC adapter (included) can be plugged into the machine to accomplish this. This is common in medical settings and with Fit-Key Programs.

Touchscreen

Touchscreen allows the user to select any program or key feature on the console with just a finger tip touch of the screen. The StepOne offers workout program options that can be selected from the touchscreen display (Menu screen example shown below). Six programs are shown on the screen at one time, additional programs can also be viewed by touching the “More” key on the screen.

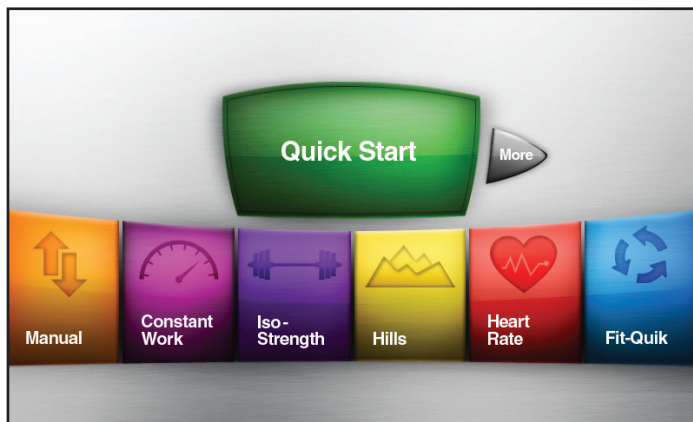

When a workout program has been selected, the console will then advance to the “Data Entry” mode where additional information is entered prior to the workout commencing.

The user will have two options of entering data as each category is displayed on the screen.

- Using the numerical touchscreen keypad (No. #1).
- Using the “+” or “-” arrow keys (No. #2).
- When the correct information has been entered, touching the “Accept” button will save the data and advance to the next category or begin the workout if it is the last category (No. #3).

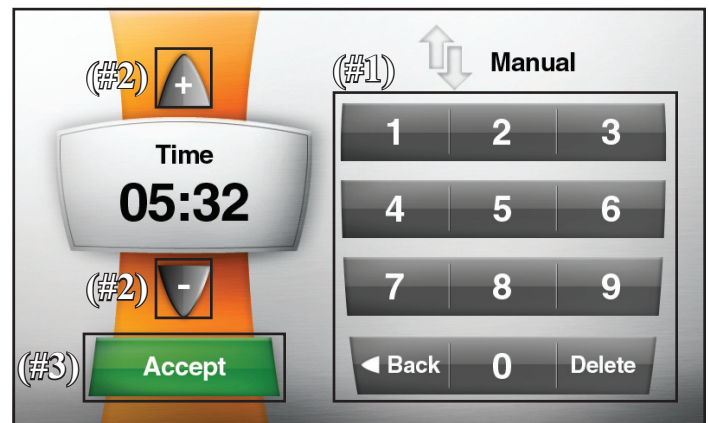

PROGRAM INSTRUCTIONS

Programs

The StepOne machine offers eight workout programs (Not including Quick Start). The following is a summary of the first six programs.

Quick Start

Allows the user to get on the machine and go. Touching the “Quick Start” key at the main screen begins a workout with no set time limit. The intensity level can be changed by pressing the “Menu” key on the screen to view additional key features.

Touch the  key.

Changing The Intensity Level:

Touch the  key.

Additional key features will appear at the bottom of the screen.



Touching the “Increase or Decrease” keys will change the workout intensity level.

Manual Workout

Allows the user to set the intensity at any level. This level will not change unless the user manually increases or decreases the intensity.

Touch the  key.

Using the data entry options described on page 13.

Enter the workout duration:

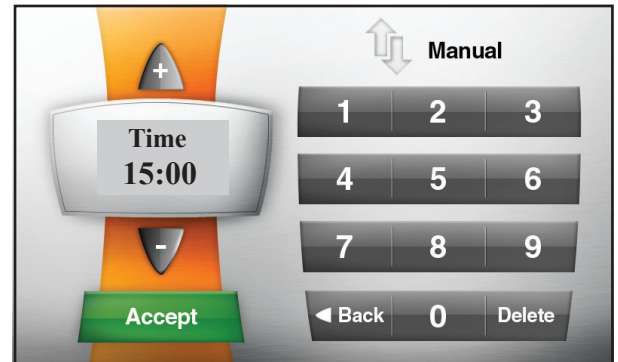

Touch the  key.

Select the level intensity:



Touch the  key.

Enter the user weight:



Touch the  key and begin the workout.

PROGRAM INSTRUCTIONS

Constant Work

Workout resistance is automatically adjusted to compensate for any change in pedal speed (SPM), thus workload (Watts) will remain constant at any given setting.

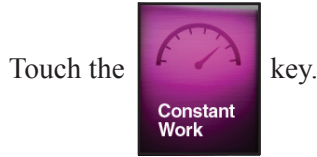

Enter the workout duration:

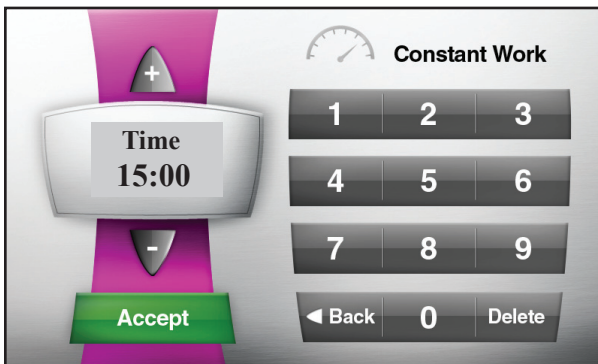

Enter the target watts:

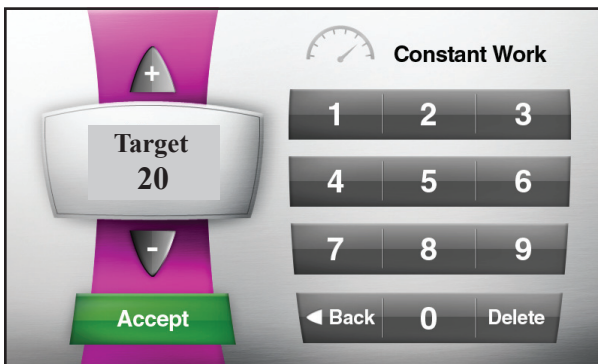

Enter the user weight:

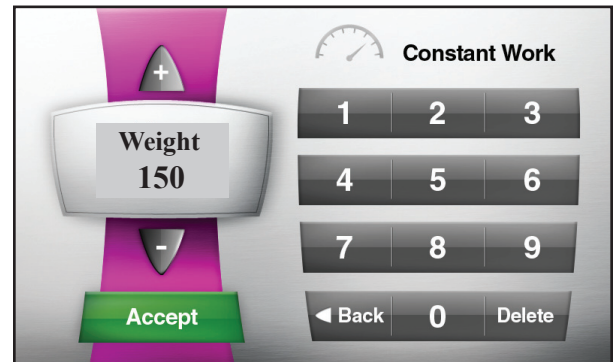

ISO-Strength Program

ISO-Strength is a isokenitic program, meaning that the unit will resist your movements in order to force you to stay at a set speed. This type of strength workout will not cause excessive soreness because it is accommodating. The console will adjust resistance to keep the user at the target SPM (Steps Per Minute)

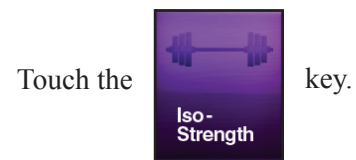

Enter the workout duration:

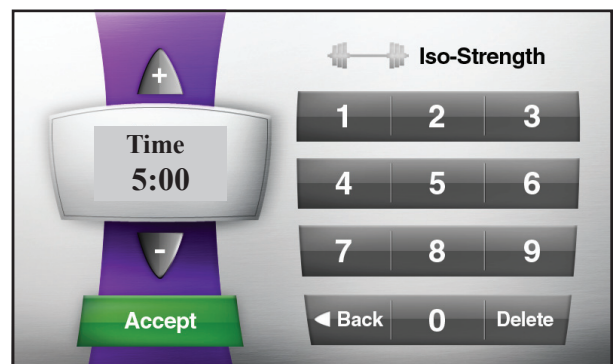

PROGRAM INSTRUCTIONS

ISO-Strength Cont'd

Enter the target SPM (Steps Per Min.):



Touch the  key.

Select the course profile:

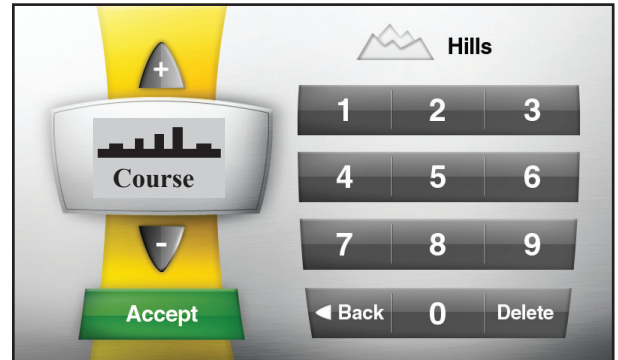

Touch the  key.

Enter user weight:



Touch the  key.

and begin the workout.

Enter the workout duration:

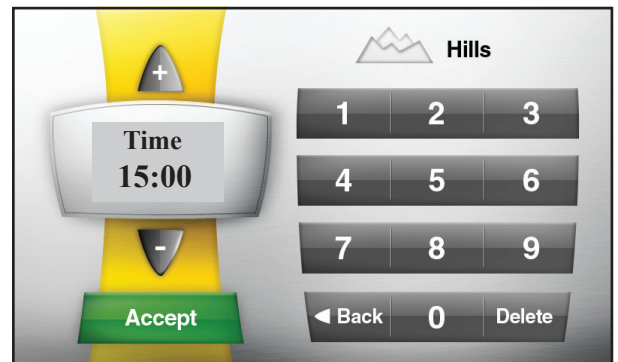

Touch the  key.

Hills Program

Allows the user to select from seven different Hill profiles set at various pre-programmed intensities.

The following profiles are available: Course, Sprints, Twin Peaks, Peak, Progressive, Multi-Peaks and Ramp.

Touch the  key.

Select the level intensity:

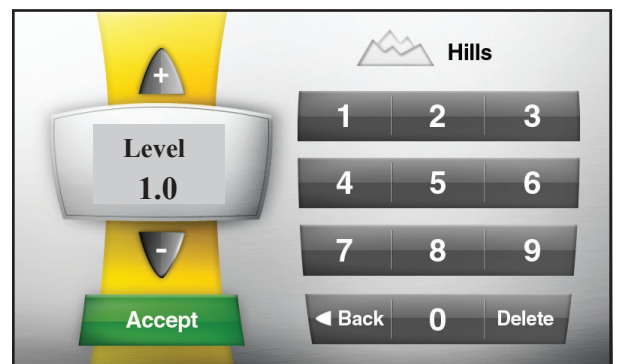

Touch the  key.

PROGRAM INSTRUCTIONS

Enter the user weight:

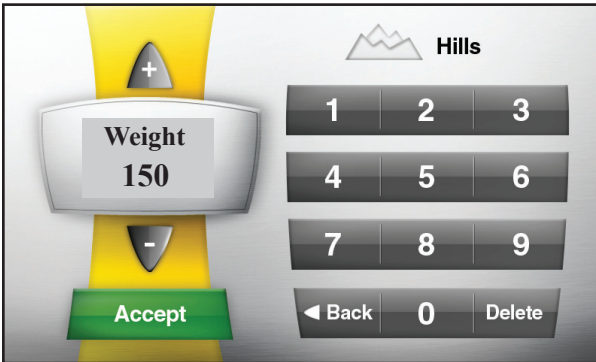

Touch the  key.
and begin the workout.

Heart Rate Program

A heartrate transmitter cheststrap is required for this program. Refer to page 12 for a complete instruction on using the strap and to understand how to calculate your target heart rate.

- Place the transmitter strap on your chest

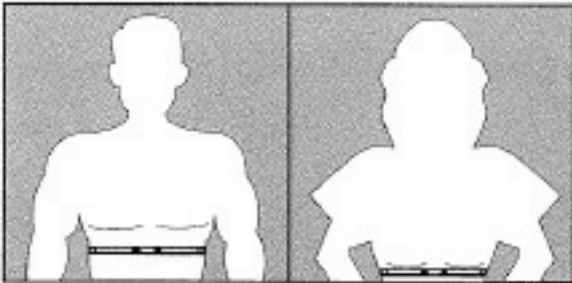

⚠ ATTENTION

If you are not wearing a transmitter belt or the belt is not sending a signal correctly, after a short period of time the following message will appear.

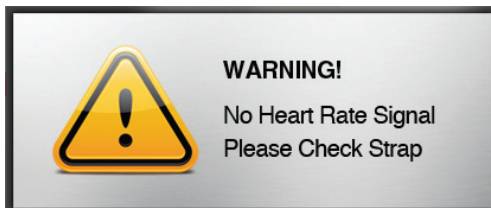

If the signal continues to be undetected the program will exit and return to the main screen.

Touch the  key.

Enter the workout duration:

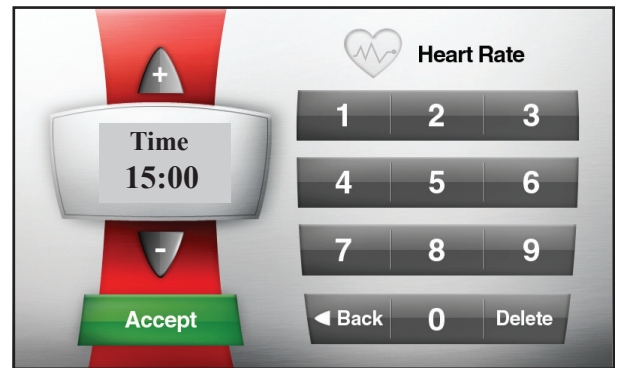

Touch the  key.

Enter the target heart rate:

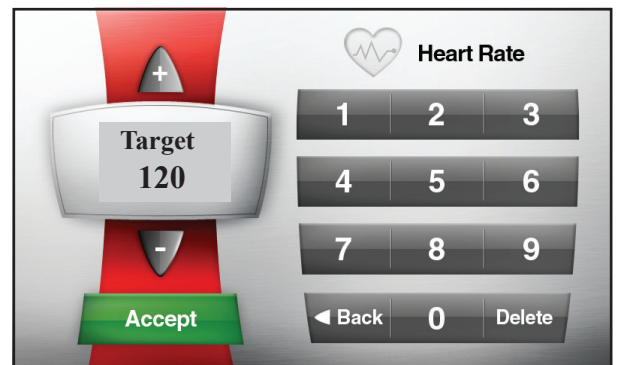

Touch the  key.

PROGRAM INSTRUCTIONS

Heart Rate Cont'd

Enter the user weight:

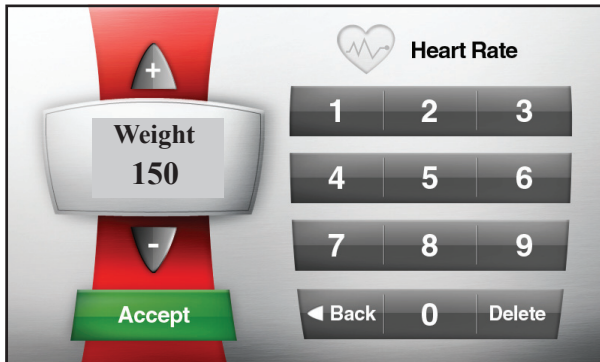

Touch the  key.
and begin the workout.

Fit Quik®

Allows the user to select a two stage program of cardiovascular work with ISO-strength (Isokinetic). Work loads and time durations are preset within the Set-Up mode.

The following category is only seen when Manual, Hills or Constant Work is selected in the “Set-up mode”.



Enter the user weight:

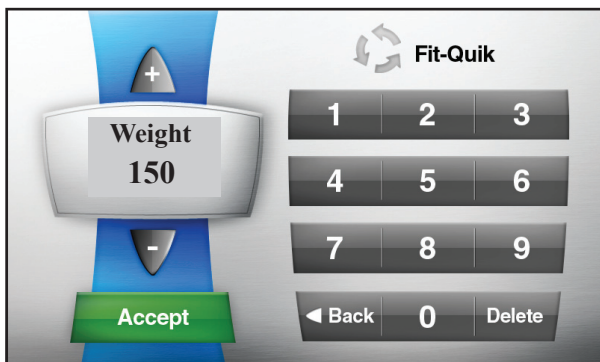

Touch the  key.
and begin the workout.

More

Pressing this key will change the screen to show an additional two more pre-programmed workout profiles: Random and Stress Test.

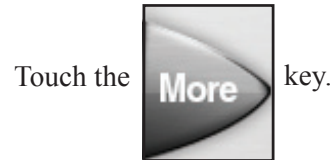

Random Program

This program randomly displays different workout profiles each with its own level of difficulty. The user only has to choose the type of profile, length of workout time and the level difficulty.

Note: The highest column of the profile represents the highest workout level you selected. Columns below it are percentages of the level selected.



Select the course profile:

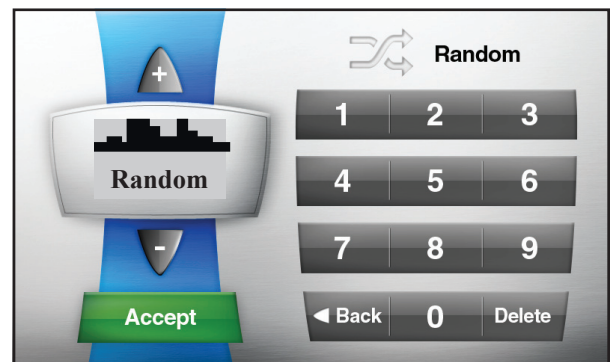

Touch the  key.

PROGRAM INSTRUCTIONS

Random Cont'd

Enter the workout duration:

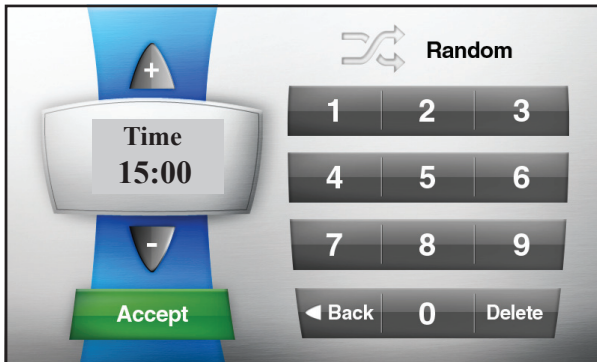

Touch the  key.

Select the level intensity:

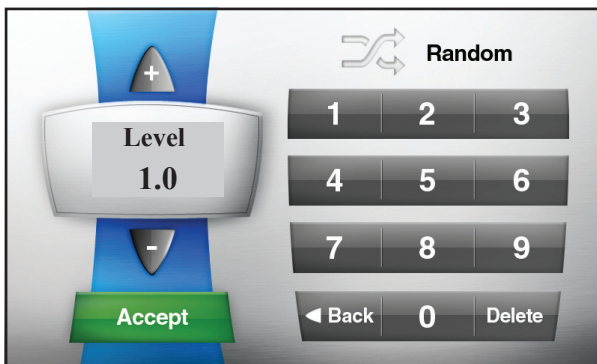

Touch the  key.

Enter the user weight:

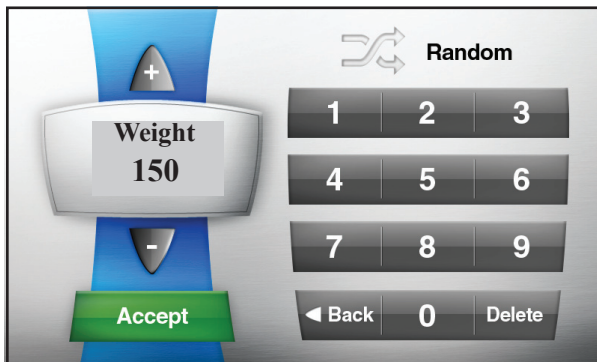

Touch the  key.
and begin the workout.

Stress Test

A designed stress test to be used as a training program or use with other diagnostic devices (if applicable). The user sets a target wattage with timed intervals and preset wattage increments.

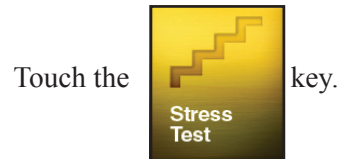

Touch the  key.

Enter the wattage target:

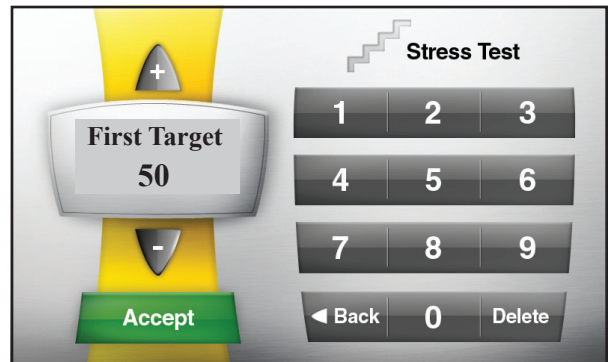

Touch the  key.

Enter the wattage increments:

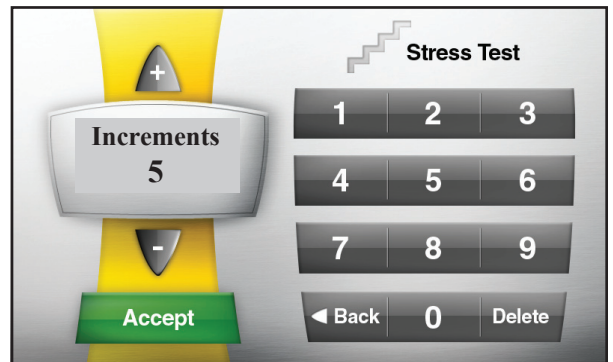

Touch the  key.

PROGRAM INSTRUCTIONS

Stress Test Cont'd

Enter the time intervals:

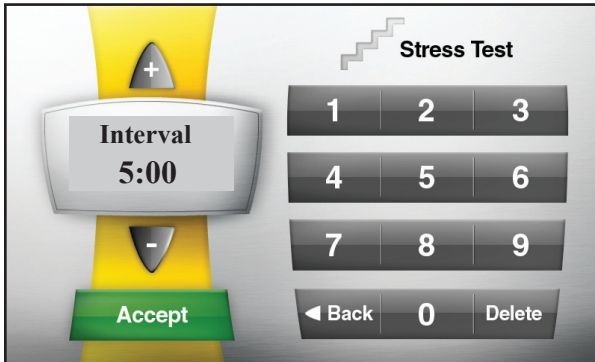

Touch the  key.

Enter the user weight:

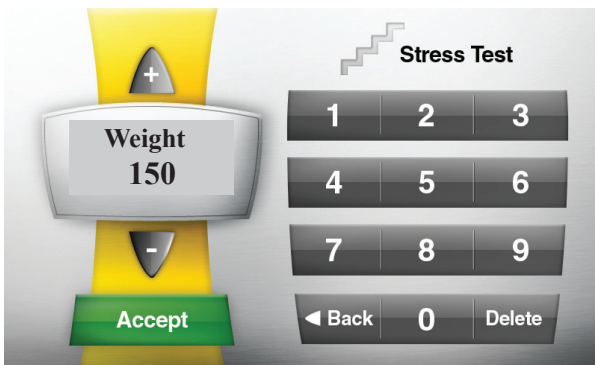

Touch the 

and begin the workout.

ADDITIONAL KEY FEATURES

The SCIFIT touchscreen console also includes extra user friendly key features that may be accessed during a workout.

Once a workout commences, the word “Menu” will appear in the lower right corner of the screen.

Just a touch of the “Menu” icon activates a pop-up menu that appears at the bottom of the screen for additional selections.

Touch the  key.

Pop-up menu with additional key features appear.



Key Descriptions



Allows the user to change the viewing format of the workout profile and data displayed on the screen during the workout.



Allows the user to change the intensity of the workout.



Pauses the workout program at anytime. The screen then changes providing the user with three options as shown below.



Change

Returns to the data entry screen where the information previously entered can be changed.

Continue

Restarts the workout program at the point where the user had paused it.

Stop

Exits the workout and returns to the main screen.



This activates two 3-speed cooling fans (Low, Medium, High) at anytime during the workout. Each touch of the key will change the fan airflow speed.



This feature increases resistance for a short duration of time during the workout when activated. Touching this key will activate the feature and a short count down will be seen on the screen to prepare the user. The duration length of the “Power Burst” can be increased or decreased in the “Set-up” mode.

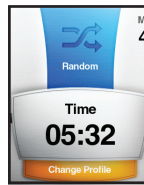

Only seen when the “Random” program is selected. It allows the user to change the current workout profile at the bottom of the screen to a different one by touching the “Change Profile” key anytime during the workout.

Set-Up Mode Access

This code allows the operator to access the “Set-Up Mode” screen customizing the program parameters for the operator needs.

To enter the “Set-Up Mode”:

Press the [One Dot], [Six Dot] and the [ENTER] keys at the same time. The screen will then change and display various categories that may be customized (Also see “Set-Up Mode Document” on the www.SCIFIT.com website).

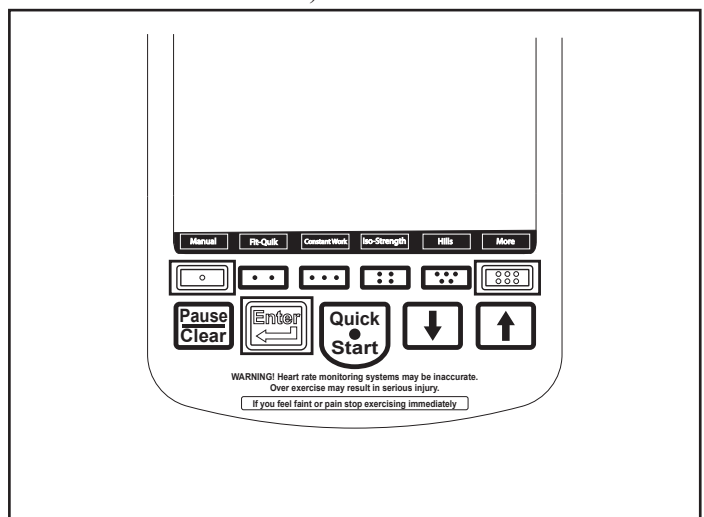

MAINTENANCE & SERVICE

Maintenance

The StepOne is virtually maintenance free. After training, always wipe down your SCIFIT exercise product. Perspiration that continuously settles on the frame, upholstery, covers, and console may eventually cause rust or damage. Damage resulting from lack of maintenance is not covered under warranty.

If defective components are identified and require replacement, the equipment should be put out of service until repaired.

CAUTION

Always follow manufacturers instructions for proper care and use. Failure to follow manufacturers instructions may result in injury to yourself.

StepOne Maintenance Schedule

Any mechanical or electrical work conducted within the main body of a medical CE class IIa unit **MUST BE RECALIBRATED**. The generic maintenance schedule below should be applied to both medical CE and non-medical products

COMPONENT	USE	WHEN	BY WHOM
Covers, Seat, Handlebars and Console	Damp Cloth	Daily	Club Maintenance
LCD Screen	Damp Cloth	Weekly	Club Maintenance
Battery	Voltmeter	Every 6 Months	Club Maintenance
Seat Assy. Base Frame Roller Guide and Adjustment Pan	Damp Cloth	Every two weeks	Club Maintenance
Lower Linkage Connections	High Use - Check Bimonthly Low Use - Check Every 6 mo.		Club Maintenance

CAUTION

Contact your local waste management agency for specific requirements concerning recycling and disposal locations of batteries.

UNITED STATES CUSTOMER SERVICE

For assistance in the service of SCIFIT products;

phone : +1 (918) 359-2000
 fax : +1 (918) 359-2045
 e-mail: service@scifit.com

The Product Support department is available by means of email. A voice mail service is available 24 hours a day for recording messages to request technical support and to order replacement parts. Our mailing address is:

SCIFIT Systems Inc.
 5151 S. 110th E. Ave.
 Tulsa, OK 74146
 USA

UK & EUROPEAN CUSTOMER SERVICE

phone : +44 1344 300022
 fax: +44 1344 868838
 e-mail: info@scifit.uk.com

SCIFIT LTD (UK)
 Lexham House
 Forest Road
 Binfield
 Berkshire, RG42 4HP
 UK

Company Number: 5970624 (UK)

*COUNTRIES OUTSIDE OF UK & EUROPE
 PLEASE USE USA CONTACT NUMBERS*

Order online 24/ 7 at www.SCIFIT.com

WARRANTY

It is very important that your SCIFIT machine is registered. This can be done online at <http://www.SCIFIT.com/warrantyregistration.shtml> or fill out and mail the registration form on the back of this manual.

SCIFIT Statement of STEP ONE™ Warranty Only

SCIFIT warranties new products against defective workmanship and/or materials under normal and proper use subject to the following limitations:

(a) SCIFIT's obligation to the original purchaser shall apply within the United States and Canada to both parts and the cost of labor required to replace or repair a defective product, at SCIFIT's option, for a period of one (1) year from *user/dealer purchase date as documented by *warranty card and if warranty card has not been returned by user/dealer, then date of shipment from the factory*. Thereafter, for a period of four (4) years, such obligation shall extend only to the supply of replacement parts with any labor costs associated with such replacement or repair to be at buyer's expense. Refer to clause (e) for components outside this policy clause.

Outside the United States and Canada SCIFIT will repair or replace defective product with no labor included for a period of three (3) years from user purchase date as documented by *warranty card and if warranty card has not been returned by user then date of shipment from factory. However these warranty periods for sales outside the United States and Canada are subject to modification by local SCIFIT sales dealers.

*Note: Original purchaser must register their purchased products either by warranty card return, web site registration or fax to activate warranty period or shipment date is extant for start of warranty period. A ninety (90) day period is to be given for warranty registration to allow stock rotation and showroom stock thereafter registration will be shipment date for the start of the warranty period.

(b) SCIFIT's obligation shall be limited to repairing or replacing defective parts. No allowance shall be granted for repairs made by Buyer without SCIFIT's prior written approval. The decision to replace or repair shall be solely at SCIFIT's discretion. SCIFIT reserves the right to require return of warranty parts, or payment, in some cases. See "Return of Parts" below.

(c) SCIFIT's warranty does not apply to parts requiring replacement or repair due to normal and abnormal wear and tear, improper use, corrosion (perspiration), improper maintenance, improper installation, improper rated, grounded or dedicated electrical circuits or improper storage, nor does it apply where all or part of the product has been altered from its original state by Buyer or a third party.

(d) THIS WARRANTY IS IN LIEU OF ALL OTHER WARRANTIES, EXPRESSED OR IMPLIED, ARISING BY LAW OR OTHERWISE INCLUDING WARRANTY OR MERCHANTABILITY OF FITNESS FOR PARTICULAR PURPOSE, AND IS IN LIEU OF ALL OTHER LIABILITIES OF SCIFIT INCLUDING DIRECT, INDIRECT, SPECIAL AND CONSEQUENTIAL DAMAGES OR PENALTIES EXPRESSED OR IMPLIED WHETHER ARISING OUT OF CONTRACT, NEGLIGENCE OR OTHER SORT.

WARRANTY

SCIFIT Statement of Warranty

(e) The below listed items have the following warranty coverage unless determined to be defective. These items include, but are not limited to:

STEP ONE™	Warranty Period
Upholstery	12 months
Saddles/Seats	12 months
Pedals/Foot beds	12 months
Rubber grips	12 months
Frame*	10 years
Battery	1 year
Brake	3 years
Seat frame pedestal (seatpost)	3 years
Console membrane switch	3 years
Springs and Drive belts	3 years

*Frame includes: Base and Main frame

Accessories Products	Warranty Period
Pedal straps	Normal wear & tear
Heart rate receiver/Transmitter	90 days
Assist gloves	90 days
Leg stabilizer	12 months

(f) Fires, floods, and acts of God, are not covered under this warranty.

WARRANTY

Freight and Shipping

All SCIFIT products have displayed on the outside packaging “**STOP – UPON DELIVERY INSPECT MERCHANDISE THOUROUGHLY NOTING ANY DAMAGE ON RECEIVING PAPERWORK PRIOR TO SIGNING**”.

.....

Shipping and Installation

SCIFIT is not responsible for the repair or replacement of any unit or part damaged during transit or installation. The customer is responsible for inspection of each unit and part for shipping damage at the time of installation. **If the customer signs an unqualified receipt for freight or damage goods, the customer is solely responsible for the cost of the repair or replacement for such freight damage.**

.....

Software, Trademarks, Copyrights and Patents

If an order includes computer software, such software is transferred by SCIFIT to the customer pursuant to a single user license, the royalty terms and conditions of that are set forth on or in the package accompanying the software.

SCIFIT has trademarked several names to uniquely identify its business and products. These names must not be used by other entities and remain the exclusive right of SCIFIT. SCIFIT’s decals, user manuals, and service manuals are copyrighted and may not be copied without prior written approval from SCIFIT.

SCIFIT owns patents on designs and features that are unique to its products. SCIFIT will defend these patents against those who attempt to utilize these features and designs in other products.

WARRANTY

Maintenance

After using, always wipe down your SCIFIT exercise product. Perspiration that continuously settles on frame, upholstery, casings and control panels may eventually cause rust or damage. Damage resulting from lack of maintenance WILL NOT be covered under warranty. To clean upholstery, use mild soap and warm water, then dry with a clean towel. Refer to the machine maintenance schedule.

.....

Product Support

Assistance for the service of SCIFIT products is available by

- Fax: +1 (918) 359-2045
- Phone: +1 (918) 359-2040
- Toll Free: +1 (800) 745-1373
- Email: Service@SCIFIT.com

The product support department is staffed from 7 AM to 5 PM US Central Time Monday through Friday. A voicemail service is available 24 hours daily for recording messages to request technical support and to order replacement parts. Our goal is to return every voicemail call within 30 minutes of when it is placed during our normal business hours. Some parts may also be purchased online using a credit card at: www.SCIFIT.com

Please have the following information prior to calling technical support:

- Model number of equipment
 - Serial number of equipment
 - Point of contact name and phone number
 - Detailed description of symptoms encountered.
-

Parts Shipment

During the first 30 days warranty parts will be shipped via overnight delivery. Determination must be made before 2:00 PM US Central Time on any given weekday for next day delivery. During the remainder of the first year warranty period, parts requirements will be filled via ground shipment. The customer will have the option to request overnight or 2nd day parts shipping, but will be charged the difference between the ground shipment cost and the overnight or 2nd day cost.

WARRANTY

Return of Parts

SCIFIT is committed to continual improvement in the equipment we market. In order to meet this commitment, the rapid return of defective parts is essential. The examination of the parts by our engineering department leads to changes that insure the same problem does not re-occur. Thank you in advance for your assistance!

When requested by SCIFIT, defective parts must be returned to the SCIFIT factory within 20 days of receipt of replacement part. SCIFIT reserves the right to invoice buyer and collect for parts where SCIFIT has requested the parts be returned and buyer has refused to do so.

Please follow these three easy steps for returning parts.

Step 1

Keep the box and packing material in which the new parts arrived.

Step 2

A **prepaid return label** will be in the parts box for only those parts that need to be returned. If no prepaid return label is enclosed contact SCIFIT product support at

- Phone: +1 (918) 359 - 2040
- Toll Free: +1 (800) 745 -1373
- Email: Service@SCIFIT.com

When **ALL** of the parts are received and inspected at the factory, a credit will be issued for the original parts invoiced. **Attention service companies** – Labor invoices will **NOT** be paid until the defective parts are returned to the factory.

Step 3

Wrap the defective part, place it in the box and affix the return label for a safe return.

Service Labor

Where applicable, the SCIFIT product support personnel will arrange a local field service technician to provide field support. Every effort will be made to schedule service during 48 business hours (8 hours per business day) following notification of a problem or as soon as repair parts are available to the field service technician. Where possible, parts will be supplied in advance of the field service technicians so that the product is repaired with one call.

Purchased Parts

All purchased parts will carry a 12 month warranty. Refer to purchased parts shipments and installation for more information.

This Limited Commercial Warranty supercedes the Limited Commercial Warranty printed in the "Owner's Operation Manual" for all SCIFIT Systems, Inc. products.

If you have questions or require additional information, please contact SCIFIT Systems, Inc. at:

- Phone: +1 (918) 359 - 2040
- Toll Free: +1 (800) 745 - 1373
- Email: Service@SCIFIT.com

CERTIFICATIONS

If your StepOne machine has CE on the label followed by "0434", it is a medical machine. The label will be located at the front of the machine next to the serial number.



DECLARATION OF CONFORMITY

Address: SCIFIT Ltd (UK)
Lexham House, Forest Road
Binfield, Berkshire, RG42 4HP
United Kingdom

EU Support: +44 1344 300022
Email: info@scifit.uk.com
Web: www.scifit.uk.com

Manufacturer: SCIFIT Ltd (UK)

Product: Step One – Stepper
Class A (high accuracy class) per EN957-1:2005
Class S (commercial use class) per EN957-1:2005

We, SCIFIT Systems, Inc., hereby declare that the product listed above is in conformity with the following standards and/or normative documents:

ISO 9001:2008
EN 957-1:2005
EN 957-8:1998
EN 60601-1-2:2007
EN 60601-1:2006
EN 62304:2006



Steve Wright
European Business Development Director
April 2, 2013



0434

DECLARATION OF CONFORMITY

Address: SCIFIT Ltd (UK)
Lexham House, Forest Road
Binfield, Berkshire, RG42 4HP
United Kingdom

EU Support: +44 1344 300022
Email: info@scifit.uk.com
Web: www.scifit.uk.com

Manufacture: SCIFIT Ltd (UK)

Product: Step One – Recumbent Stepper
Class IIa device per rule 10 of Annex IX of 93/42/EEC.
Class A (high accuracy class) per EN957-1:2005
Class S (commercial use class) per EN957-1:2005

We, SCIFIT Systems, Inc., hereby declare that the product listed above is in conformity with the essential requirements of the EC Council Directive 93/42 EEC Medical Device Directive, as amended by 2007/47/EC and is in conformity with the following standards and/or normative documents:

ISO 13485:2003
ISO 9001:2008
EN 957-1:2005
EN 957-8:2003
EN 60601-1-2:2007
EN 60601-1:2006
EN 62304:2006



Steve Wright
UK Managing Director
17 January, 2013



DET NORSKE VERITAS
MANAGEMENT SYSTEM CERTIFICATE

Certificate No. 24833-2008-AQ-NLD-NA

This is to certify that the Management System of:

SCIFIT Ltd (UK)
at
Lexham House
Forest Road, Binfield
Berkshire
RG42 4HP
United Kingdom

has been found to conform to the standard:

ISO 9001:2008

This Certificate is valid for the following product or service ranges:

Supply, installation and support for medical and general fitness cardio equipment within health clubs and medical environments.

Initial Certification date: 15 April 2008
Place and date: Havik, 9 May 2011

This Certificate is valid until: 15 April 2014
for the Accredited Unit: DET NORSKE VERITAS CERTIFICATION AS, NORWAY

The audit has been performed under the supervision of:
Tony Harper
Lead Auditor



Eugenie Winger Husebye
Eugenie Winger Husebye
Management Representative

Lack of fulfillment of conditions as set out in the Certification Agreement may render this Certificate invalid.
This Certificate has been digitally signed. See www.dnv.com/2008certificates for more info.
HEAD OFFICE: Det Norske Veritas AS, Veritansenter 1, 1372 Høvik, Norway. Tel: +47 67 92 90 00 Fax: +47 67 92 91 11 www.dnv.com



DET NORSKE VERITAS
MANAGEMENT SYSTEM CERTIFICATE

Certificate No. 10268-2007-AQ-NLD-NA

This is to certify that the Management System of:

SCIFIT Ltd (UK)
at
Lexham House
Forest Road, Binfield
Berkshire
RG42 4HP
United Kingdom

has been found to conform to the standard:

ISO 13485:2003

This Certificate is valid for the following product or service ranges:

Supply, installation and support for medical and general fitness cardio equipment within medical environments.

Initial Certification date: 15 April 2008
Place and date: Havik, 9 May 2011

This Certificate is valid until: 15 April 2014
for the Accredited Unit: DET NORSKE VERITAS CERTIFICATION AS, NORWAY

The audit has been performed under the supervision of:
Tony Harper
Lead Auditor



Eugenie Winger Husebye
Eugenie Winger Husebye
Management Representative

Lack of fulfillment of conditions as set out in the Certification Agreement may render this Certificate invalid.
This Certificate has been digitally signed. See www.dnv.com/2008certificates for more info.
HEAD OFFICE: Det Norske Veritas AS, Veritansenter 1, 1372 Høvik, Norway. Tel: +47 67 92 90 00 Fax: +47 67 92 91 11 www.dnv.com



SCIFIT® Warranty Card

Register online at <http://www.SCIFIT.com/warrantyregistration.shtml> or complete this form, fold it and return it to SCIFIT. We request you send this card within 2 weeks after your equipment has been delivered to insure proper warranty registration.

Company Name _____

Contact Name _____

Address _____

City/State/Zip _____

Home Phone (____) _____ Business Phone (____) _____

Model Purchased _____

Date Received _____ Serial Number _____

Entity Purchased From _____

City/State _____

Please rank the following reasons (1 through 6) for selecting SCIFIT with 1 being most important:

____ Features ____ Quality ____ Price ____ Dealer ____ User Friendly ____ Appearance

Please Check the appropriate box(es) on how you were introduced to SCIFIT:

Saw in _____ Magazine Introduced by SCIFIT Dealer

Saw at _____ Tradeshow Referred by SCIFIT User

Other _____

Comment _____

Thank You For Choosing



www.SCIFIT.com

P2278Rev.B

5151 South 110th East Avenue
Tulsa, OK 74146

SCIFT

_____ From

Important: Please keep this page for "Recalibration records"

Model Number: _____

Serial Number: _____

Date of Purchase: _____

Calibration Date
Medical Units: _____

Supplied By: SCIFIT Systems Inc.

User Manual: #A5583A (5/2013)

	DATE	CLUB OR CERTIFICATION LOCATION	CERTIFIED SERVICE COMPANY	TECH INITIALS
1st Recalibration				
2nd Recalibration				
3rd Recalibration				
4th Recalibration				
5th Recalibration				

Please make extra copies for future use



THIS PAGE LEFT BLANK INTENTIONALLY



Scientific Solutions For Fitness™

Order online 24/7 at www.SCIFIT.com