

# NuStep® TRS 4000

## Recumbent Cross Trainer Service Manual Complete



**We Transform Lives.**



## HOW TO OBTAIN CUSTOMER SUPPORT AND PARTS

### STEP 1

#### **Identify the problem.**

Speak with the person who reported the problem to get a good understanding of the problem.

### STEP 2

#### **Verify the problem on the NuStep stepper.**

Use this manual to verify and/or service the problem and/or determine what parts are required.

### STEP 3

#### **Record the serial number of the NuStep stepper and the cumulative steps taken.**

The serial number is located at the top end of the electronic tube directly behind the display.

The display has a “stepmeter” that shows cumulative steps. To show the steps, press and hold the reset button and then press the “up” arrow while continuing to hold the reset button.

Read the cumulative steps across the HEART RATE, METS/WATTS and WORKLOAD LCD screens. There will be a total of 9 digits and the value is displayed for 5 seconds. Repeat if necessary.

### STEP 4

#### **Contact Customer Support at NuStep Inc.**

**To support our customers better, you must have the serial number, cumulative steps, complete description of the problem, and part or item number(s) required to service the problem for our product specialists.**

Our Product Specialists are ready to help you 8:00 a.m. - 4:30 p.m. EST.

Email, Call, or Fax Customer Support at:

Email            support@nustep.com  
Phone:         (800) 322-4434 or (734) 769-3939 x 5  
Fax:            (734) 769-8180  
Address:       NuStep Inc.  
                  5111 Venture Dr. Ste. 1  
                  Ann Arbor MI 48108-1654

International customers may obtain customer support by contacting their local NuStep distributor.

NuStep® is a registered trademark of NuStep, Inc.

United States Patent Nos. 5,356,356, 6,361,479 B1, 6,042,518, 6,666,799, D359,777, D421,075, and other patents pending.

TRS4000 Service Manual P/N 41904B

Copyright May 2005 by NuStep, Inc. All rights reserved.

*The information in this manual is the most current at the time of printing. Due to our commitment toward continuous improvement, specifications and descriptions are subject to change without notice. No part of this manual may be reproduced or transmitted in any form or by any means, electronic or mechanical, for any purpose without the express written permission of NuStep, Inc.*

## ABOUT THIS MANUAL



Your NuStep is made with high quality components designed for long life and durability. In the event the NuStep needs service, this manual provides some information for a mechanically qualified person to service it. The following important items tell more about the manual.

### Service Manual Coverage

This Service Manual - Complete covers NuStep TRS4000 products built beginning in 1999.

### Service Instructions

We hope you like the digital photos that show how to perform the service. Each instruction begins with a helpful list of required tools that you will need to complete the job. Please follow the Steps in order. The major instruction steps are above the photos while others are directly below the photos. Please read NOTES and GOTO instructions carefully. They contain important information to save you time and direct you to the next applicable step.

Finally, solid arrows  usually point toward the part/action described, while dotted line arrows  indicate direction of movement.

### Directional References

All directional references -- left, right, front, back, side, top, bottom -- are from a user's perspective as if sitting on the seat of the NuStep, unless noted. Please note that these directional references still refer back to the original reference, even when the NuStep is placed on its side.

### Part Names, Part Numbers, and Item Numbers

Please match parts from the digital photos to the Schematic Drawings and Parts List to obtain Item and Part Numbers.

### Operating Instructions

This service manual does not include operating instructions. The NuStep TRS4000 Operating Manual is sent with each NuStep. Additional copies can be obtained from NuStep Inc.



### CAUTION

This is the safety alert symbol. It is used to call attention to instructions concerning personal safety. Read and obey all safety messages that follow this symbol to avoid possible injury or death resulting from misuse.



### CAUTION

CAUTION indicates a potentially hazardous situation, which if not avoided, may result in minor or moderate injury. It may also be used to alert against unsafe practices.



### CAUTION

The TRS 4000 is very heavy; it weighs 205 lbs (93 kg). To avoid injury, or damage to the product, always obtain assistance to move this product.

Use proper lifting technique.



### CAUTION

Do not operate this product unless all covers, guards, and parts are in place and securely fastened.

Do not operate this product if it appears damaged or inoperable.

## Preventive Maintenance

### Break-In Period, Preventive Maintenance Intervals

#### Break-in Period

Most mechanical products “break-in” after which bearings roll more freely, bushings rotate better, belts stretch, and parts loosen up a little. This is normal. Your TRS4000 is designed to accommodate this “break-in” with no adjustment on your part. The resulting effect is that there is a little less friction and the unit may feel a little easier, but this is normal and the unit needs no calibration.

#### Preventive Maintenance Intervals

Your TRS4000 is designed to be maintenance free. We recommend just a few items that will increase the useful life of the NuStep. Please follow the recommended preventive maintenance intervals (in months) according to the amount of usage that the NuStep receives (hours per week). *These are estimated intervals and you may need to increase or decrease the time period between preventive maintenance depending on your actual use.*

| Preventive Maintenance  | Usage   |   |  | Action                                  | Supplies   |
|---|---|---|--|---|--|
|   | Low<br>Less than 10<br>hours per week<br>(home) | Medium<br>10–40 hours<br>per week<br>(clinical) | High<br>More than 40<br>hours per week<br>(commercial) |   |  |
| Clean covers, arms, seat and display. Wipe off perspiration, dirt and dust. | Monthly   | Weekly  | Daily  | Clean                                   | Non-abrasive spray cleaner like Fantastik® and a soft cloth.   |
| Replace batteries.  | Every 12 months                                 | Every 3 months                                  | Every 1 month  | Replace                                 | (4) AA alkaline batteries.<br><br>Rechargeable batteries are not recommended due to voltage requirements of the display. |
| Check drive belts for signs of wear.  | Every 12 to 24 months                           | Every 6 to 12 months                            | Every 3 to 6 months                                    | Gently turn NuStep onto side and check. | None, if no action required. Parts, if action required.  |

## Contents

|  |     |
|--|-----|
| <b>How to Obtain Customer Support</b> .....                            | ii  |
| <b>About This Manual</b> .....   | iii |
| <b>Preventive Maintenance</b>  |     |
| Break-in Period .....  | iv  |
| Preventive Maintenance Intervals .....                                 | iv  |
| <b>Service Instructions</b> (The Parts List item # is in parenthesis). |     |
| <b>Arms - Upper</b>  |     |
| Foam Grip (55) Replacement .....                                       | 1   |
| Upper Arm (1 & 2) .....  | 2   |
| Arm Lock (3) .....   | 3   |
| <b>Arms - Lower</b>  |     |
| Arm Lock Knob (70) .....   | 4   |
| Arm Lock Weldnut Repair Kit .....                                      | 5   |
| Arm Lock Knob Repair Kit .....   | 6   |
| Lower Arm (4 & 5) & Bearings (8 & 9) & Pivot Shaft (129) .....         | 7   |
| Pivot Cam (158) Adjustment .....                                       | 32  |
| Pivot Cam Removal – see Lower Arm                                      |     |
| <b>Cover</b>   |     |
| Cover Removal/Installation (38 & 39 & 40) .....                        | 12  |
| Seat Position Indicator Label (72) Replacement .....                   | 15  |
| <b>Display</b>   |     |
| Battery Changing .....   | 16  |
| Display Removal/Installation (43) .....                                | 17  |
| Display Accessory Kit Installation (181) .....                         | 18  |
| Polar Receiver (100) .....   | 19  |
| <b>Drivetrain</b>  |     |
| Bearings – Shaft (10) .....  | 20  |
| Belt Idler Arm (18) .....  | 22  |
| Belt Idler Spring (136) – see Poly-V Belt & Sheave                     |     |
| Belt Idlers (19) .....   | 24  |
| Connecting Link (37) .....   | 26  |
| Flat Belt (189) & Belt Idler Spring (136) .....                        | 28  |
| Front Shaft Alignment .....  | 30  |
| Magnet – EC & Pivot Disks .....  | 31  |
| Pivot Casting Boot (23) – see Footpedal                                |     |
| Pivot Disk Assembly (99) – call Customer Support @ NuStep Inc          |     |
| Pivot Shaft (129) – see Lower Arm                                      |     |
| Pivot Shaft Alignment .....  | 33  |
| Poly-V Belt (12) & Sheave (101) & Belt Idler Spring (136) .....        | 34  |
| Poly-V J6 Flex Belt (12) & Sheave Without Grooves (101) .....          | 36  |
| Rear Shaft (130) & Timing Belt Sprockets (147) .....                   | 38  |
| Rear Shaft Alignment .....   | 41  |
| Timing Belt (13 & 14) .....  | 42  |
| Timing Belt Springs Replacement (139) .....                            | 46  |
| Timing Belt Sprocket – see Rear Shaft                                  |     |

## Contents

|  |     |
|--|-----|
| <b>Eddy Current (EC) Magnetic Resistance System</b>  |     |
| EC Ball Plunger (45) Replacement and Adjustment .....  | 47  |
| EC Disk (46) & Bearings (7) .....  | 48  |
| EC Magnet (47) .....   | 51  |
| EC Magnet Gap Alignment (47) .....   | 52  |
| EC Plunger Plate (50) & EC Magnet Slide Bracket (49) .....   | 53  |
| Load Lever (75) .....  | 56  |
| Workload Level PCB (94) .....  | 57  |
| <b>Electronics</b>   |     |
| DC Power Cable (169) .....   | 58  |
| Hall Effect Sensor (124) .....   | 60  |
| Ribbon Cable (31) .....  | 62  |
| VR Sensor (125) .....  | 63  |
| <b>Electronic Tube</b>   |     |
| Display Boot (21) – see Electronic Tube  |     |
| Electronic Tube (52) .....   | 65  |
| Electronic Tube Boot (22) – see Electronic Tube  |     |
| <b>Frame</b>   |     |
| Main Frame – call Customer Support @ NuStep Inc.   |     |
| Step Through Support (140) .....   | 67  |
| Wheel (156) & Axle (6) .....   | 68  |
| <b>Footpedal</b>   |     |
| Footpedal 1999 (56 & 57) .....   | 69  |
| Footpedal 2000 (56 & 57) .....   | 71  |
| Footpedal Bearing Replacement (8) .....  | 73  |
| Footpedal Bumper Upgrade .....   | 74  |
| Footpedal Stabilizer 2000 (161) .....  | 75  |
| Footpedal Support Tube 1999 .....  | 78  |
| Footpedal Support Tube Retaining Ring Removal 1999 (to reduce arm tension) ....  | 80  |
| <b>Seat</b>  |     |
| Seat (110) & Swivel (141) & Seat Channel (116) .....   | 81  |
| Seat Armrest (111) & Seat Armrest Bracket (112 & 113) .....  | 85  |
| Seat Assembly (115) Removal/Installation .....   | 86  |
| Seat Locking Upgrade .....   | 87  |
| Seat Mounting Bracket Assembly (117) .....   | 89  |
| Seat Mounting Bracket (117) & Seat Release Lever Bracket (122)<br>& Swivel Release Lever Bracket (142) & Springs (135 & 137) & Nyliners (93) ..... | 93  |
| Seat Position Indicator (118) .....  | 98  |
| Seat Rail (119) & Seat Stop Pin (123) & Angle Cover Mount Bracket (24) .....   | 99  |
| Seat Release Bracket (120) & Seat Release Bracket Spring (138)<br>& Nyliners (93) .....  | 101 |
| Seat Release Bracket With Stud (120) & Seat Release Spring (138) .....   | 103 |
| Seat Release Lever (121) .....   | 107 |
| Seat Wheel (157) .....   | 109 |
| Swivel Release Lever (143) .....   | 110 |
| <b>Appendix</b>  |     |
| Troubleshooting Guide .....  | A   |
| Parts List 1.4 .....   | C   |
| Figure 1.4 NuStep Assembled View – Part Names .....  | E   |
| Figure 2.4 NuStep Exploded Parts View – Outer Part Item Numbers .....  | F   |
| Figure 3.4 NuStep Exploded Parts View – Inner Part Item Numbers .....  | G   |





## Foam Grip Replacement

---

### Tools Required

Utility knife  
Rubbing alcohol  
Space heater

### 1. Cut off old grip.



### CAUTION

To avoid injury, use care when cutting foam grip.

### 2. Preheat grip till soft and warm, pour or spray inside w/ rubbing alcohol.



Shake grip to distribute alcohol and shake out excess rubbing alcohol.

### 3. Push grip on.



A combination of mostly pushing and a little pulling and twisting works best.

## Upper Arm (R or L)

*NOTE: This instruction applies to all variations of arm locks. Make sure to use the screws that came with the kit if you are installing a complete arm assembly.*

### Tools Required

Phillips screwdriver

Grease or silicone (white/clear preferred)

### 1. Loosen knob.



### 2. Remove 2 screws.



*NOTE: If you are installing a new arm assembly, make sure to use the screws that came with the kit, not the screws removed here.*

### 3. Slide cap up arm, and then pull upper arm out of lower arm tube.

### 4. To install upper arm, do above steps in reverse order.

### INSTALLATION NOTES:

A. Make sure components are properly installed before installing arm. *NOTE: arm lock may be either white or black.*

B. Wipe a little grease inside top 4" of lower arm tube before installing. This prevents squeaking of arm lock & tube.

C. The machine key always faces and comes in contact with the stud end of the knob and the holes/indents align with the screws on the bottom of the tube. R and L arms tilt inward ~ 20°.

D. When tightening screws in Step 2, make sure screws go into the holes/indents on the arm lock, not against it. The arm lock must float freely. The screws keep arm lock from coming out.

### Reference Picture:

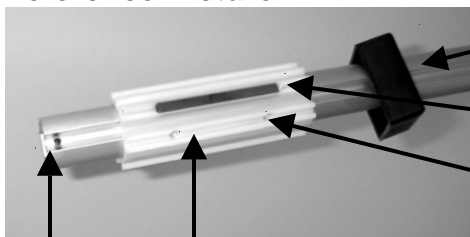

Cap

Machine Key (may be rectangular or T shaped)

Holes/indents in arm lock that screws go into (they do not screw into here)

Pin

Arm lock (white or black)

## Arm Lock

*Note: This instruction applies to all units, but units with S/N  $\geq$  411092 use part number 4087 Arm Lock and units with S/N  $\leq$  411091 use part number 4088 Arm Lock. Part number 4088 has a "T" shaped machine key.*

### Tools Required

Hammer  
Pliers  
Nail punch  
Safety glasses



### CAUTION

To avoid injury, wear safety glasses.

**1. Remove upper arm.** See *Upper Arm* instruction.

**2. Tap roll pin through first hole.**



**3. Pull pin from second hole.**



**4. Remove arm lock and slide new arm lock onto upper arm.**



**5. Install roll pin.**



*To ensure the new arm lock is not installed backwards, note the machine key's position relative to the upper arm groove while removing the arm lock.*

**6. Install upper arm.**

## Arm Lock Knob

*NOTE: Units with S/N  $\geq$  411924 do not have a snap ring on the end of the knob stud. Units  $\leq$  411924 do, but it is not necessary to reinstall it once removed.*

### Tools Required

Needle-nosed pliers  
Grease/silicone (white/clear)  
Safety glasses



**CAUTION**

To avoid injury, wear safety glasses.

**1. Remove upper arm.** See *Upper Arm* instruction.

**2. Remove snap ring from end of knob stud if it has one. If not, continue.**

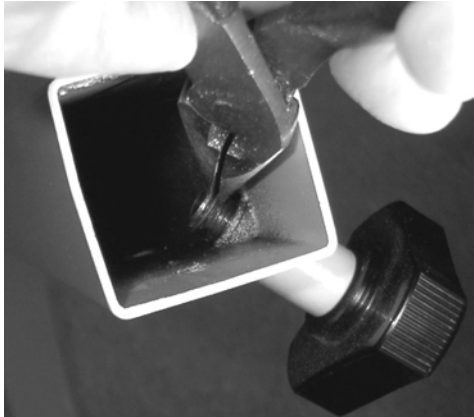

**3. Thread old knob out.** It may be hard to thread out if it had a snap ring on it.

*No photo.*

**4. Lubricate threads on new knob and thread into arm. Wipe up excess lube. You do not have to install snap ring back on.**

*No photo.*

**5. Install upper arm per instructions.**

*No photo.*

## Arm Lock Weldnut Repair Kit

*Note: This instruction applies to units with S/N  $\leq$  412391. For S/N 411001 - 411091, use part number 4112. For S/N 411092 - 412391, use part number 4114.*

### Tools Required

Hammer  
Cold chisel  
Phillips screwdriver

Torque wrench  
Safety glasses

**1. Remove upper arm.** See *Upper Arm* instruction.

**2. Install new arm lock.** See *Arm Lock* instruction.

**3. Remove remaining weldnut from underside of arm weldment (both weldnuts must be removed to install the nut plate).**



**4. Insert nut plate into arm weldment and align threads with arm weldment holes. Thread screws into nut plate until the tip of the screw is flush with the surface of the nut plate.**



*For S/N 411092 - 412391, note the direction reference written on the nut plate.*

**5. Install upper arm.** (See *Upper Arm* instruction.) **Do not over tighten screws - maximum torque = 7.5 in-lbs.**

## Arm Lock Knob Repair Kit

### Tools Required

Drill  
 31/64" drill bit  
 Tap wrench  
 9/16" socket and ratchet  
 9/16" wrench  
 9/16" - 12 tap  
 Safety glasses

### CAUTION

To avoid injury, wear safety glasses.

1. Remove upper arm. See *Upper Arm* instruction.
2. Remove arm lock knob. See *Arm Lock Knob* instruction.
3. Drill out arm lock knob hole using 31/64" drill bit.
4. Tap hole using 9/16" - 12 tap.



5. Using the repair kit, thread the 3/8" - 24 nut all the way onto the bolt, then thread the threaded insert on the bolt (make sure slot on threaded insert is facing the nut and head of bolt).
6. Use the bolt to thread threaded insert into hole until 1/16" - 1/8" of the insert sticks out of the end of hole. Remove bolt leaving threaded insert in place.



7. Install upper arm. See *Upper Arm* instruction.
8. Install arm lock knob. See *Arm Lock Knob* instruction.

## Lower Arm (R / L) & Bearings & Pivot Shaft

*NOTE: This instruction applies to all units, but units with S/N  $\geq$  412137 have the cam shown in Steps 7 & 25 and those lower do not.*

### Tools Required

½" socket and ratchet  
 Large flat head screwdriver  
 5/32" hex key  
 (3) 2x4 blocks of wood (Very helpful!)  
 Long Phillips screwdriver  
 Hard rubber or plastic hammer

Loctite 242  
 Grease/silicone (white/clear)  
 Torque wrench  
 Scratch awl  
 Safety glasses

**1. Remove covers.** See *Cover Removal* instruction.



**2. Disconnect stabilizers or support tubes from footpedals.**

**Remove both footpedals.**

See *Footpedal 1999* and *Footpedal Support Tube 1999* or *Footpedal 2000* and *Footpedal Stabilizer 2000* instructions depending on your model.

**3. Remove step through support.**

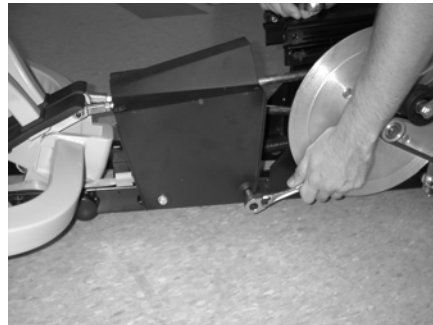

**4. For S/N  $\leq$  428173, disconnect timing belt springs.** See *Timing Belt Springs* instruction.

**5. Remove left and right side nuts that attach rod ends to arms.**

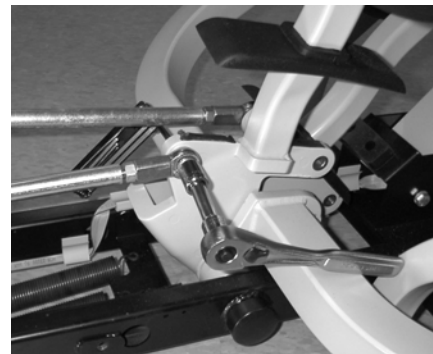

## Lower Arm (R / L) & Bearings & Pivot Shaft

**6. Pry off both rod ends with large screwdriver. Let arms rotate forward against footpedal bumper.**

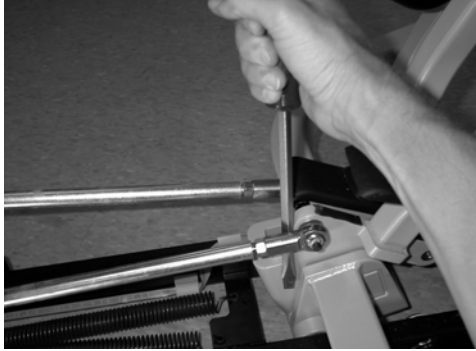

### CAUTION

To avoid injury, or damage to the product, use caution when removing or installing. Hold arm weldment before prying rod end off bolt to prevent weldment from falling forward.

**7. Remove plug and loosen (don't remove) (6) screws on both sides.**  
*NOTE: Early models don't have this assembly, so GOTO Step 8.*



**8. Loosen setscrews that hold pivot shaft. There may be (2) or (4) total on both sides.**



**9. Place one 2x4 under main shaft pivot and one 2x4 on end under each arm.**

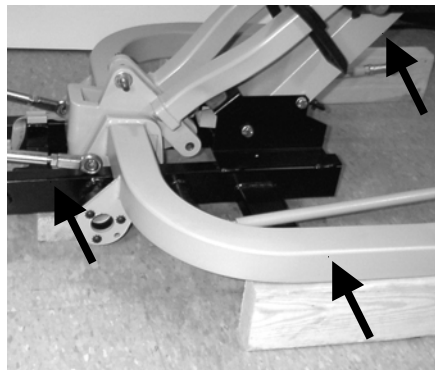

*NOTE: If you are just replacing the shaft do Step 10, then GOTO 17.*

**10. Place Phillips screwdriver into hole on end of shaft (most models) and drive carefully out right to left.**

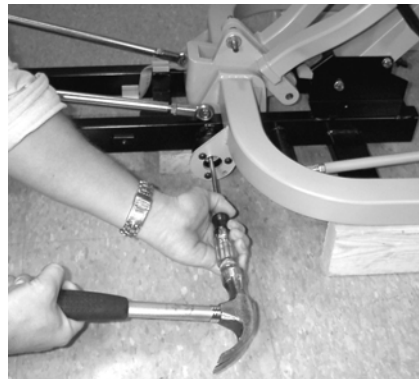

*NOTE: You will have to wiggle arms when driving shaft out.*



## Lower Arm (R / L) & Bearings & Pivot Shaft

---

**11. Carefully lift left arm out.**



**12. Carefully lift right arm out.**

*No photo.*

**13. If you are just replacing either lower arm, do it now. Transfer parts from old to new. GOTO Step 16.**

*No photo.*

**14. To replace bearings, insert screwdriver against end of bearing wall and gently tap out. Be careful not to scar bore.**



**15. To insert bearings, carefully tap into bore using a block of wood and hammer.**

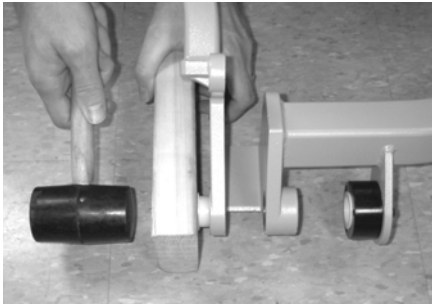

**16. Place arm assemblies back into the frame and back onto wood blocks.**



## Lower Arm (R / L) & Bearings & Pivot Shaft

**17. Shaft direction. Radius end in first, groove end last.** *NOTE: Early models may not have the groove.*

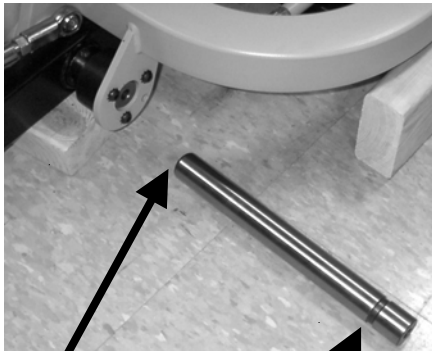

Radius end

Groove end

**18. Carefully tap shaft through bearings but do not force. You must wiggle arms as you go, otherwise bearings will be damaged. Work shaft through one bearing at a time.**



**19. Remove top right setscrew and tap shaft into position so that groove aligns with setscrews.**

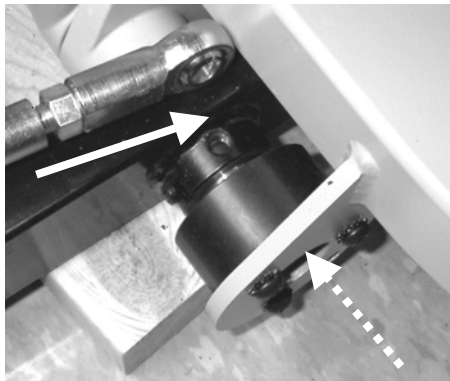

**20. Tighten all setscrews securely. Right side setscrews must lock into groove to prevent shaft movement.**



**21. Place a few drops of Loctite 242 on shoulder bolt threads and shoulder.**



### CAUTION

To avoid injury and prevent adverse health effects, use Loctite in accordance with the manufacturer's material safety data sheets, including the use of safety glasses and impermeable gloves. Material safety data sheets are available via the internet at [www.loctite.com](http://www.loctite.com) or by calling Henkel Corporation at (800) 562-8483.

## Lower Arm (R / L) & Bearings & Pivot Shaft

---

**22. Place rod ends onto shoulder bolts and tighten nuts to 200 inch-lbs.**

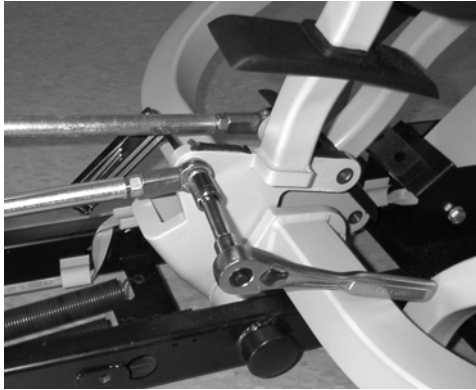

### Torque Setting:

200 inch-lbs

**23. Wipe grease on both sides of rod ends into spaces between rod end and washer and rod end and nut.**



**24. Attach footpedals, stabilizers (or footpedal tubes) and then attach springs.**

*No photo.*

**25. Set cams to eliminate “play” from arms. Insert scratch awl into hole with slight pressure. While keeping pressure on awl, tighten screws with hex key.**



*NOTE: Cams are set correctly when “play” is removed from arms, but cam is not set too tightly, which can increase arm resistance.*

**26. Insert plugs, install covers and slide boots back in place.** *No photo.*

## Cover Removal / Installation

***NOTE: Removing the covers is the first step for every service issue under them. Once service is completed, all covers must be installed again for safe operation.***

### Tools Required

Phillips screwdriver  
3/8" wrench

Scratch awl (use to align holes before screws)

### 1. Remove seat rail cap.



### 2. Remove seat rail bumpers.



### 3. Roll seat off of seat rail.



*Keep upward pressure on front of seat to prevent scratching end of seat rail.*

### 4. Remove 6 screws from top cover.

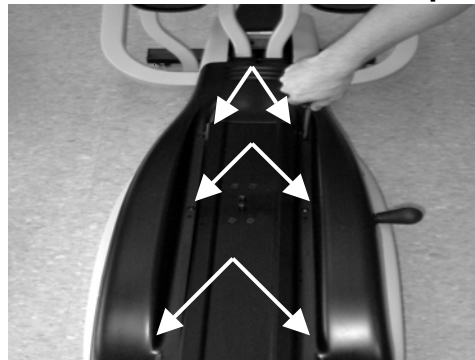

*Note: In center of top cover, 2 screws are only used in forward 2 holes.*

### CAUTION

The TRS 4000 seat assembly is heavy; it weighs 50 lbs (23 kg). To avoid injury or damage to the product, use caution when removing or installing. Obtain assistance as required. Use proper lifting technique.

## Cover Removal / Installation

---

### 5. Remove top cover.



### 6. Remove 2 screws.



### 7. Remove screw from front.



Slide boot up out of way.

### 8. Remove screw from rear.



### 9. Remove left side cover.



Pull rear outward, then nose.

### 10. Remove right side cover.



Pull rear over wheel & workload lever.

## Cover Removal / Installation

---

**11. To install cover, do previous steps in reverse order. Note the following:**



Install nose of side covers first.....



then push rear of covers over wheels.



Hang side covers on bracket directly below seat rail.



For top cover, place awl in third hole from front to align holes, then insert 3 screws. Repeat for opposite side.

## Seat Position Indicator Label Replacement

---

### Tools Required

Rubbing alcohol

**1. Remove old label. Clean label area with rubbing alcohol and let dry.**

*No photo.*

**2. Expose one inch of new label. Attach this edge to forward bottom corner of non-textured area on left side of cover.**

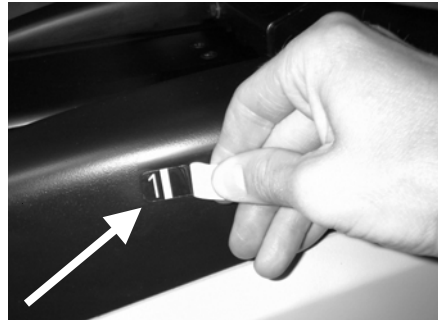

**3. Remove remainder of adhesive backing while holding front edge of label down.**

*No photo.*

**4. Carefully align label along bottom edge of non-textured area. *NOTE: Do not pull hard on label while doing this, otherwise it will stretch!***

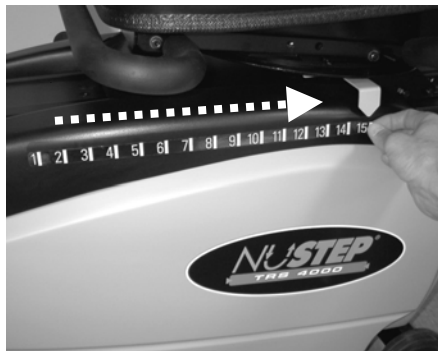

**5. Gently smooth label down. Don't press down too hard the first time or bubbles and creases may develop.**

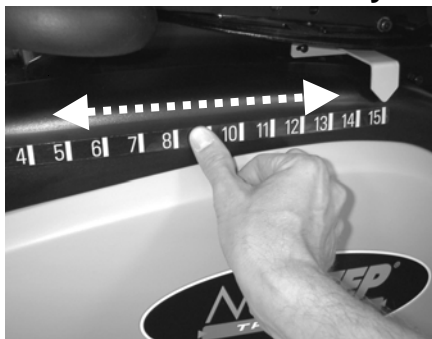

**6. Align Seat Position Indicator if needed. See *Seat Position Indicator* instructions.**

*No photo.*

## Battery Changing

---

### Tools Required

Phillips screwdriver

- 1. Remove 2 screws that attach battery access panel.**

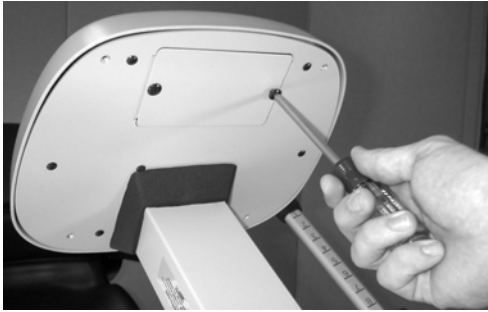

- 2. Replace batteries. Use 4 AA alkaline batteries. Rechargeable batteries are not recommended due to voltage requirements of the display.**



- 3. Replace battery access panel.**  
*No photo.*



## Display Removal / Installation

### Tools Required

Phillips screwdriver

**1. Slide boot down tube and remove three screws. Hold onto display before removing third screw so it doesn't fall!**

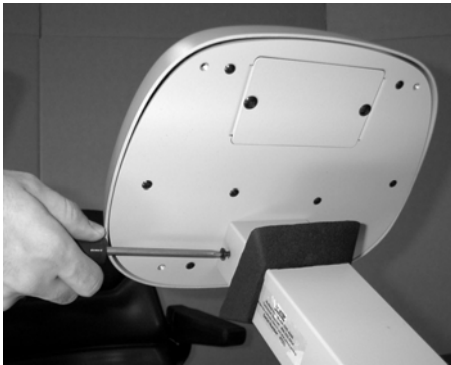

**2. On back of display, push 2 locking tabs outward on each side of connector to unlock cable connector.**

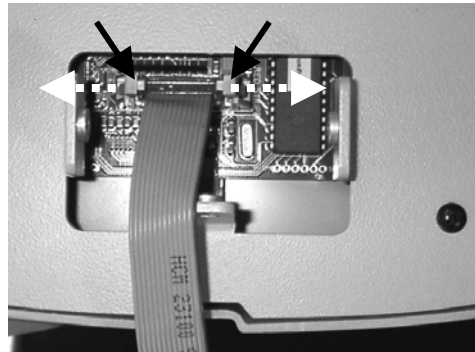

**3. Hold onto cable connector and pull outward from display connector.**

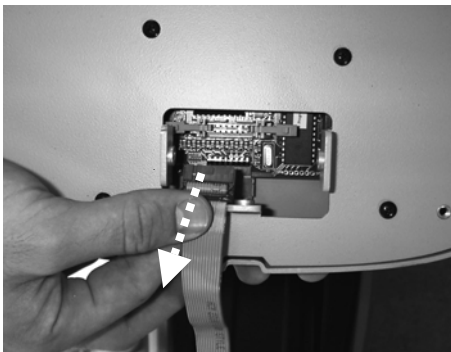

**4. To install, align key on cable connector with slot on display connector.**

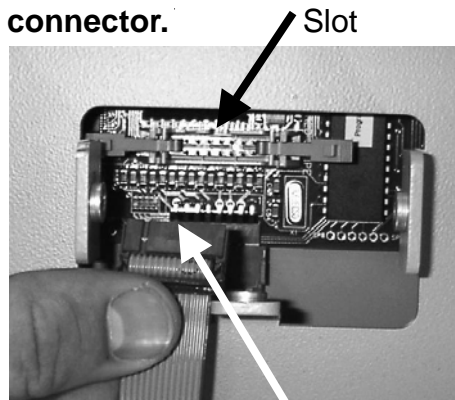

Key

**5. Push 2 locking tabs inward until they snap in place to secure cable.**

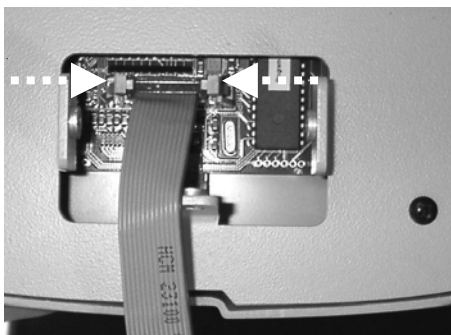

**6. Hold onto display so it doesn't fall, install three screws, slide boot up. Check display operation.**

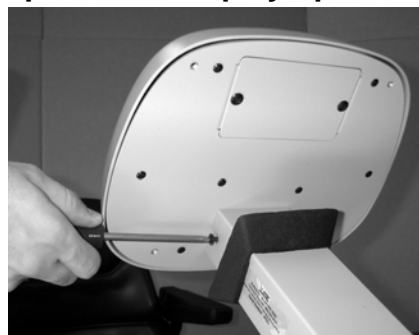

## Installation Instructions for Water Bottle Holder, Reading Rack and 123GO! Instruction Panel

*This instruction applies to the Water Bottle Holder (PN 4300), the Reading Rack (PN 4305) and the 123GO! Instruction Panel (PN 4310). The three accessories may be ordered together as the Display Accessory Kit (PN 4315). Note: the water bottle shown below is not available.*

### Tools Required

Phillips screwdriver

Attach accessories to back of display using provided screws. Note: when the display accessory kit is shipped with a TRS4000 Recumbent Cross Trainer, the screws are preinstalled in the back of the display. Remove the screws and use them to attach the accessories.



## Polar® Receiver

*NOTE: It is a good idea to change batteries during this instruction also.*

### Tools Required

Phillips screwdriver

#### 1. Remove battery access panel.



#### 2. Remove Polar receiver from jack.

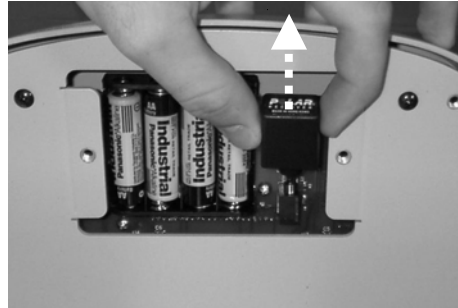

#### 3. Install new Polar receiver into jack.

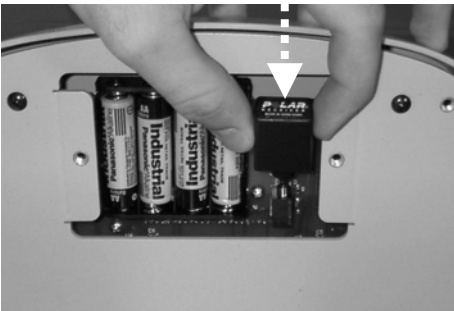

#### 4. Make sure receiver is fully inserted into jack.

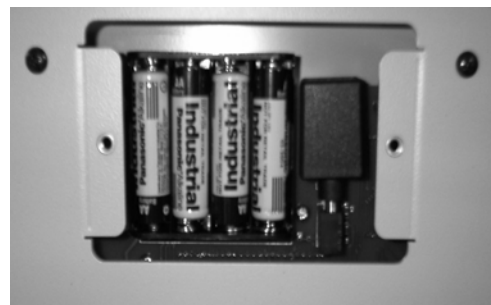

#### 5. Replace battery access panel.

*No photo.*

## Bearings - Shaft

*NOTE: This instruction applies to any 1" roller bearing (front left shown).*

### Tools Required

1/8" hex key  
 1/2" socket and ratchet  
 Flat head screwdriver  
 Torque wrench  
 Safety glasses



**CAUTION**

To avoid injury, wear safety glasses.

### 1. Remove covers.

See *Cover Removal* instructions.

### 2. For S/N $\leq$ 428173, unhook timing belt springs.

See *Timing Belt Springs* instructions.

**For S/N  $\geq$  428174, unhook belt idler spring.**

See *Flat Belt & Belt Idler Spring* instructions.

### 3. For S/N $\leq$ 428326, remove poly-v belt.

See *Poly-V Belt* instructions.

**For S/N  $\geq$  428327, remove poly-v J6 flex belt.**

See *Poly-V J6 Flex Belt* instructions.

### 4. If removing either left side bearing, remove EC disk and/or poly-v sheave.

See *EC Disk* and/or applicable *Poly-V Sheave* instructions.

### 5. Loosen set screws.



### 6. Remove nuts.

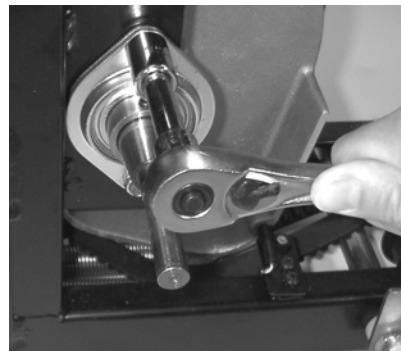

## Bearings - Shaft

---

### 7. Pry bearing off.

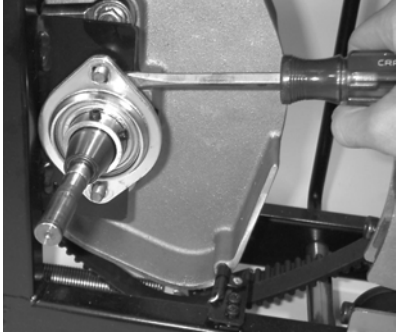

### 8. Replace bearing.

*NOTE: If replacing right side bearings, most shafts have a groove that the set screws must engage in.*

*No photo.*

### 9. Tighten nuts to 200 inch-lbs.

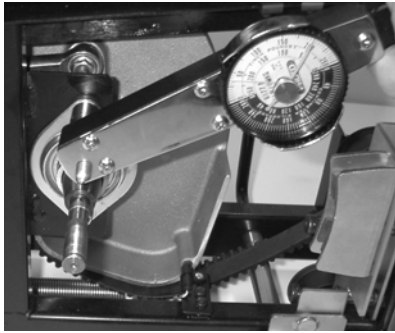

|                        |
|------------------------|
| <b>Torque Setting:</b> |
|------------------------|

|              |
|--------------|
| 200 inch-lbs |
|--------------|

### 10. Install components and covers.

*No photo.*

## Belt Idler Arm

*NOTE: This instruction applies only to units with S/N ≤ 428326.*

### Tools Required

Channel lock pliers  
 9/16" deep socket  
 2x4" block of wood  
 Hammer  
 Safety glasses

### Parts Required

½" self locking ring



**CAUTION**

To avoid injury, wear safety glasses.

### 1. Remove covers.

See *Cover Removal* instructions.

### 2. Remove poly-v belt and sheave.

See *Poly-V Belt & Sheave* instructions.

### 3. Remove self-locking ring from right side of idler arm shaft.



*Ring will be destroyed during removal.*

### 4. Remove belt idler arm from seat rail assembly.

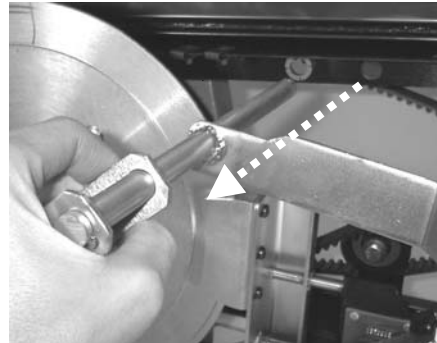

### 5. Transfer pulley. Keep the washer(s) on the side they were on.



### 6. Install belt idler arm. Make sure Nyliners don't push out of holes.

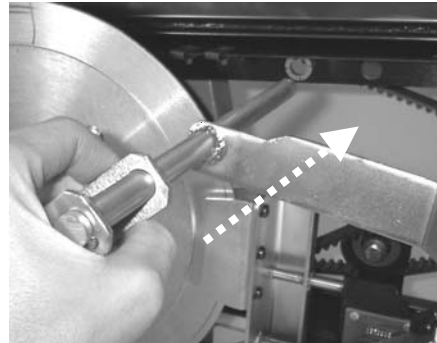

## Belt Idler Arm

---

**7. Reference photo: Close-up showing right Nyliner in hole with shaft sticking out.**

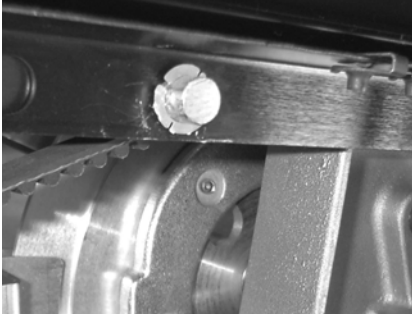

**8. Lean into 2x4 on left side, pound new self-locking ring onto end of shaft with deep socket & hammer.**



**9. Make sure idler moves up and down smoothly, then install sheave and belt.**

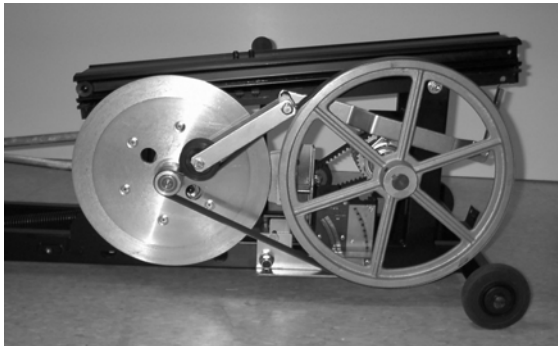

**10. Check belt alignment per *Poly-V Belt* instructions.**

*No photo.*

**11. Install covers.**

*No photo.*

## Belt Idlers – Poly-V & Right & Left Timing Belt Idlers

*NOTE: This instruction applies to all three belt idlers.*

### Tools Required

9/16" socket/deep and ratchet

9/16" wrench

**1. Remove covers.** (See *Cover Removal* instruction.) **Replace covers when steps are completed.**

### For Poly-V Belt Idler:

**2. Remove poly-v belt.** See *Poly-V Belt* instructions.

*No photo.*

*NOTE: Units with S/N  $\geq$  428327 do not have a poly-v belt idler.*

*NOTE: The idler pulley used for units with serial numbers 424793 - 428326 does not have flanges and is installed without washers.*

**3. Remove and replace idler. Install washer(s) on the side they were on.**



### For Left Timing Belt Idler:

**2. For S/N  $\leq$  428173, unhook left timing belt spring.** See *Timing Belt Springs* instructions.

**For S/N  $\geq$  428174, unhook belt idler spring.** See *Flat Belt & Belt Idler Spring* instructions.

**3. Remove and replace idler. Install all 8 washers on inside of frame.**



### CAUTION

To avoid injury, or damage to the product, use caution when removing or installing. Hold arm weldment when unhooking springs to prevent weldment from falling forward.



## Belt Idlers – Poly-V & Right & Left Timing Belt Idlers

---

### **For Right Timing Belt Idler:**

2. For S/N  $\leq$  428173, unhook left timing belt spring. See *Timing Belt Springs* instructions.

For S/N  $\geq$  428174, unhook belt idler spring. See *Flat Belt & Belt Idler Spring* instructions.

### **CAUTION**

To avoid injury, or damage to the product, use caution when removing or installing. Hold arm weldment when unhooking springs to prevent weldment from falling forward.

3. Remove and replace idler.

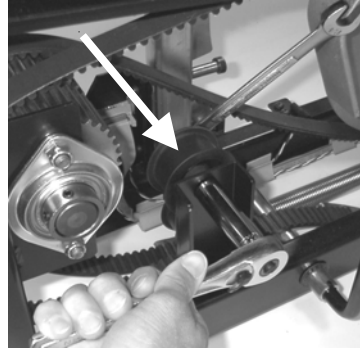

## Connecting Link

---

### Tools Required

Flat head screwdriver (long)  
 ½" socket and wrench  
 Socket extension (short)  
 Torque wrench

(2) 9/16" wrenches  
 Loctite 242  
 Grease/silicone (white or clear preferred)

**1. Remove covers.** See *Cover Removal* instructions.

**2. Remove step through support.**

**3. For S/N ≤ 428173, unhook timing belt springs.** See *Timing Belt Springs* instructions.

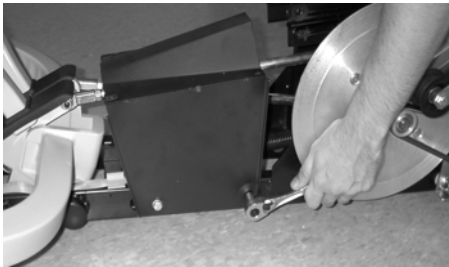

### CAUTION

To avoid injury, or damage to the product, use caution when removing or installing. Hold arm weldment when unhooking springs to prevent weldment from falling forward.

**4. Slide boot up, remove front nut.**

**5. Push right NuStep arm forward, to gain access and remove rear nut.**

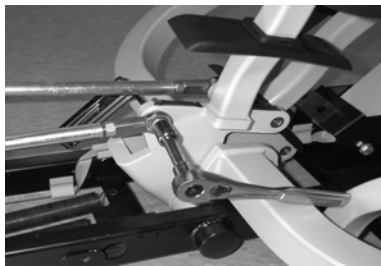

**6. Pry front rod end off shoulder bolt with large screwdriver.**



### CAUTION

To avoid injury, or damage to the product, use caution when removing or installing. Hold arm weldment before prying rod end off bolt to prevent weldment from falling forward.

## Connecting Link

**7. Pry rear rod end off shoulder bolt with large screwdriver.**

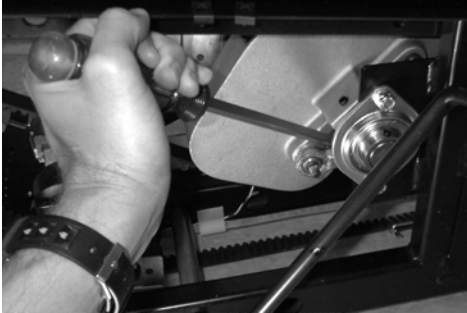

### CAUTION

To avoid injury and prevent adverse health effects, use Loctite in accordance with the manufacturer's material safety data sheets, including the use of safety glasses and impermeable gloves. Material safety data sheets are available via the internet at [www.loctite.com](http://www.loctite.com) or by calling Henkel Corporation at (800) 562-8483.

**8. Place a few drops of Loctite 242 on front shoulder bolt and threads...**



**...and do the same on rear. Don't get Loctite on rod end balls.**



**9. Place rod ends onto shoulder bolts, and tighten nuts to 200 inch-lbs.**

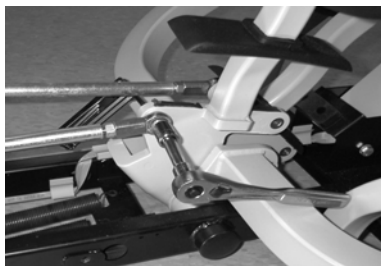

**Torque  
Setting:**

200  
inch-lbs

**10. On both rod ends, wipe grease on both sides of rod end into spaces between rod end and washer, and rod end and nut.**



**11. Slide boots down, test operation and install covers. *No photo.***

## Flat Belt & Belt Idler Spring

*NOTE: This instruction applies only to units with S/N > 428173.*

### Tools Required

5/16" wrench or nut driver  
 Measuring tape or yard stick  
 Safety glasses

### CAUTION

To avoid injury, wear safety glasses.

1. **Remove covers.** See *Cover Removal* instruction.
2. **Remove step through support assembly.** See *Step Through Support* instruction.
3. **Pull flat belt off front pulley.**



### CAUTION

Belt is under tension. To avoid injury, or damage to the product, use caution when removing or installing.

4. **Remove idler spring from flat belt clamp and right timing belt clamp.**

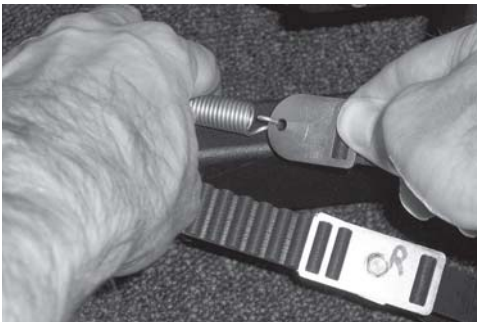

### CAUTION

Spring is under tension. To avoid injury, or damage to the product, use caution when removing or installing.

*Note: If replacing belt idler spring only, go to step 8.*

5. **Remove timing belt clamp from right timing belt.**

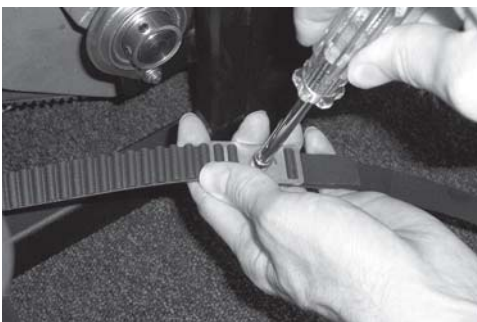

## Flat Belt & Belt Idler Spring

**6. Before installing new flat belt, verify length. To ensure proper drive train operation, the length from the end of the flat belt clamp to the end of the timing belt clamp must be 27 inches.**

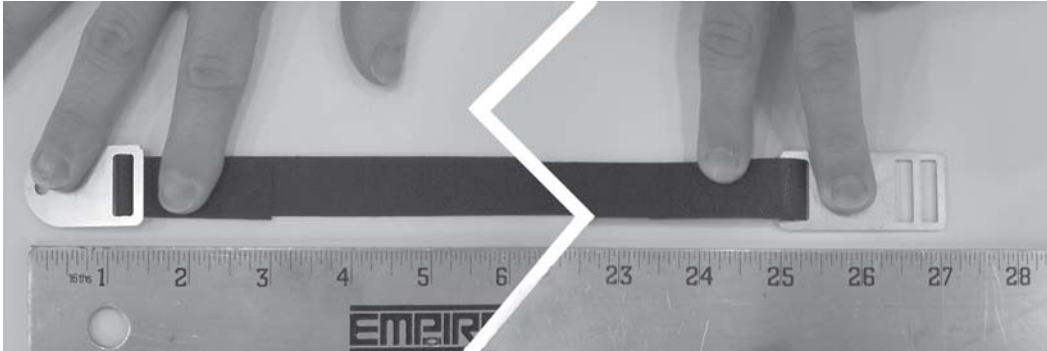

**7. Attach flat belt to right timing belt using the belt timing clamp.**

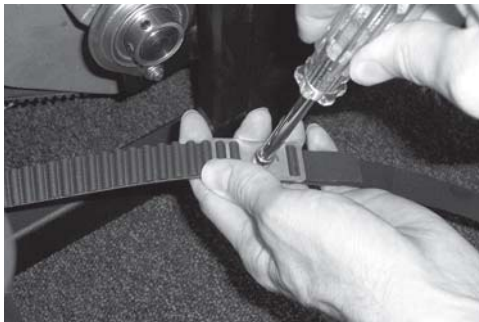

**8. Hook belt idler spring to left timing belt clamp and to flat belt clamp.**

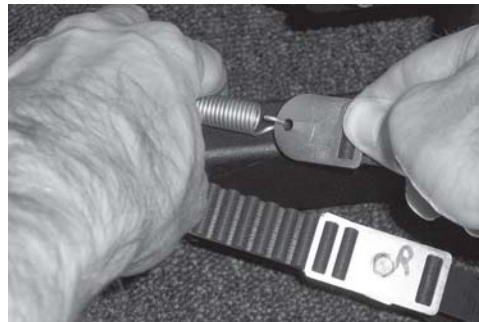

**9. Install flat belt on front pulley.**



**10. Adjust position of timing belts so they ride on the center of the timing belt sprockets. Verify that belts are properly routed on sprockets and pulleys.**

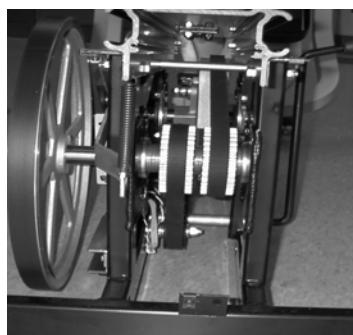

**11. Install step through support assembly and replace covers.**

## Front Shaft Alignment

*NOTE: This instruction only applies to units with S/N < 411617 and will help prevent shaft from sliding axially in bearings. Later models have a grooved shaft.*

### Tools Required

1/8" hex key  
 Loctite 290 (wicking)  
 Rawhide hammer  
 Safety glasses

### CAUTION

To avoid injury, wear safety glasses.

**1. Remove covers.** See *Cover Removal* instructions.

**2. Loosen all 4 set screws on left and right side bearings.**



**3. Tap shaft with hammer until right end of shaft aligns with end of right side bearing (shown).**

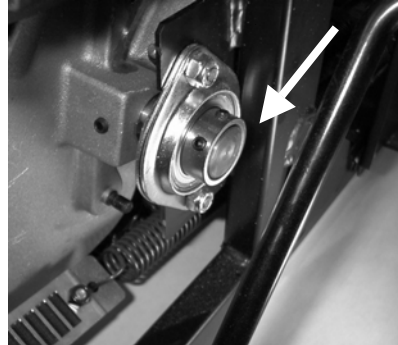

**4. Remove right side set screws and pour a few drops of 290 Loctite down into set screw holes. Tighten all 4 set screws back down.**



### CAUTION

To avoid injury and prevent adverse health effects, use Loctite in accordance with the manufacturer's material safety data sheets, including the use of safety glasses and impermeable gloves. Material safety data sheets are available via the internet at [www.loctite.com](http://www.loctite.com) or by calling Henkel Corporation at (800) 562-8483.

*NOTE: Due to Loctite strength, it is only necessary to use Loctite on right side set screws and shaft to prevent shaft from sliding axially.*

**5. Realign EC Magnet and disk before installing covers.**  
 See *EC Magnet Gap Alignment* instructions.

## Magnet – EC & Pivot Disks

*NOTE: This magnet is located on both the EC & Pivot Disks and activates the VR & Hall Effect Sensors. If the magnet was installed correctly, it will not come off. This instruction is for the unlikely event that the magnet was incorrectly attached and did come off. The instruction shows the Pivot Disk but the same steps apply for the EC Disk.*

### Tools Required

Loctite 324 adhesive

Loctite 7075 or 7387 Activator

**1. Remove covers.** See *Cover Removal* instruction.

**2. Locate the round indent on the left side of the Pivot Disk, or right side of the EC Disk. If there is residual glue or pieces of magnet, clean out as best as possible for a good mounting surface.**

**3. Wipe/spray activator into the indent, and let evaporate 10 seconds minimum.**



**5. Press red dot side of magnet into indent. The sensors will not work if red dot is out.**

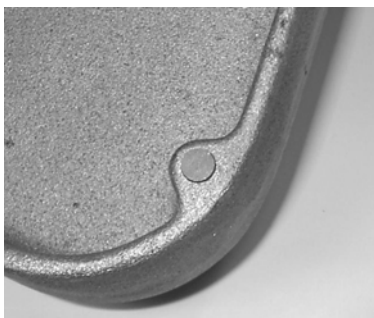

### CAUTION

To avoid injury and prevent adverse health effects, use Loctite in accordance with the manufacturer's material safety data sheets, including the use of safety glasses and impermeable gloves. Material safety data sheets are available via the internet at [www.loctite.com](http://www.loctite.com) or by calling Henkel Corporation at (800) 562-8483.

**4. Place Loctite 324 adhesive onto the side with the red (or black) dot.**



**6. Check gap. Gap should be 1/8" – 3/16" from magnet to sensor. Test display to verify operation.**

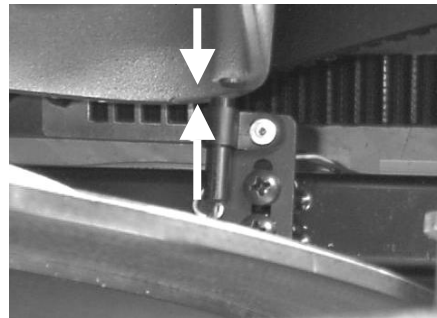

## Pivot Cam Adjustment

*Note: This instruction only applies to units with serial numbers  $\geq 412137$ . The cams serve the purpose to eliminate “play” from the arms by their outward position and by removing clearance between their bearings and the shaft they rotate on. However, if too much pressure is placed on the bearing, this can affect the amount of resistance to move the arms.*

### Tools Required

5/32" hex key  
Scratch awl

**1. Loosen (don't remove) (6) screws on both sides. Lower arms should have some play in them.**



**2. Set cams to eliminate “play” from arms. Insert scratch awl into hole with slight pressure. While keeping pressure on awl, tighten screws on awl, tighten screws with hex key.**



*NOTE: Cams are set correctly when “play” is removed from arms, but cam is not set too tightly, which can increase arm resistance.*



## Pivot Shaft Alignment

*NOTE: This instruction only applies to units with S/N < 411609 and will help prevent shaft from sliding axially in bearings. Later models have a grooved shaft.*

### Tools Required

5/32" hex key  
 Loctite 290 (wicking)  
 Rawhide hammer  
 Safety glasses



### CAUTION

To avoid injury, wear safety glasses.

**1. Rotate right arm forward to work on right side, left arm forward to work on left side.**

**2. Remove caps, loosen and remove set screws from both collars.**



*Note: Right side shown.*

**3. Tap shaft with hammer until right end of shaft aligns with end of right collar (shown).**

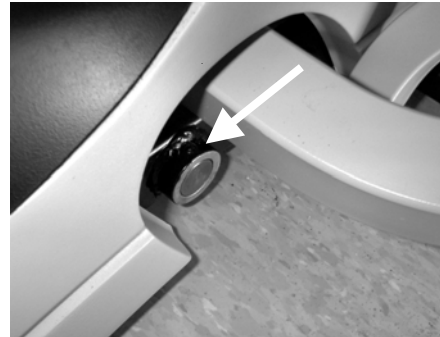

**4. With set screws removed from both sides, pour a few drops of 290 Loctite down into set screw holes. Tighten set screws back down and replace caps.**



### CAUTION

To avoid injury and prevent adverse health effects, use Loctite in accordance with the manufacturer's material safety data sheets, including the use of safety glasses and impermeable gloves. Material safety data sheets are available via the internet at [www.loctite.com](http://www.loctite.com) or by calling Henkel Corporation at (800) 562-8483.

## Poly-V Belt & Sheave & Belt Idler Spring

*NOTE: This instruction applies only to units with S/N  $\leq$  428325. Units with serial numbers  $\geq$  424793 use a black plastic poly-v sheave. Units with serial numbers  $\leq$  424792 use a cast aluminum poly-v sheave. When replacing a cast aluminum poly-v sheave with a plastic poly-v sheave, the idler pulley must be replaced as well (the new idler pulley does not have flanges).*

### Tools Required

5/32" hex key

**1. Remove covers.** See *Cover Removal* instructions.

**2. Remove belt idler spring.**

*NOTE: If you are just replacing the spring, do it now and replace covers.*

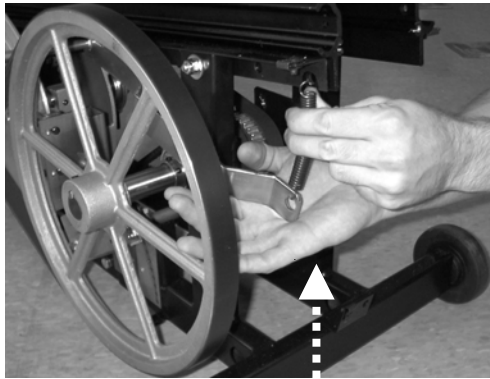

### CAUTION

Springs are under tension. To avoid injury, or damage to the product, use caution when removing or installing.

**3. To remove belt, run belt off of poly-v sheave starting with sheave first. (To install, do the opposite).**

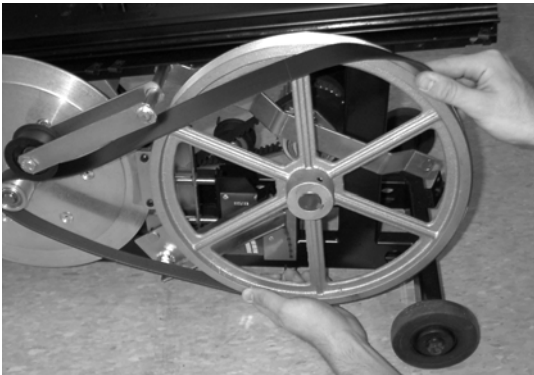

**4. NOTE: If you are just replacing the belt, install new belt and tension belt and GOTO Step 8.**

*No photo.*

## Poly-V Belt & Sheave & Belt Idler Spring

---

**5. Note location of poly-v sheave on shaft and loosen 2 set screws to remove poly-v sheave.**



**6. Install new poly-v sheave on shaft in similar position as old one. Do not tighten set screws.**

*No photo.*

**7. Install belt and tension belt. See photos for Steps 3 & 2.**

**8. Spin poly-v sheave. Belt should track directly on center of belt idler. If not, move poly-v sheave in or out on shaft until belt tracks true.**

*No photo.*

**9. Tighten 2 set screws of poly-v sheave securely. Install covers.**

*See photo above for Step 5.*

## Poly-V J6 Flex Belt & Sheave Without Grooves

*Note: This instruction only applies to units with S/N  $\geq$  428326.*

### Tools Required

5/32" hex key

Diagonal cutters or tin snips

2 zip ties (PN 30586)

**1. Remove covers.** See *Cover Removal* instructions.

**2. To remove belt, run belt off poly-v sheave.**



### CAUTION

Belt is under tension. To avoid injury, or damage to the product, use caution when removing or installing.

**3. Note: If you are just replacing the belt, GO TO Step 6.**

*No photo.*

**4. Note location of poly-v sheave on shaft and loosen 2 set screws to remove poly-v sheave.**



**5. Install new poly-v sheave on shaft in similar position as old one. Do not tighten set screws.**



## Poly-V J6 Flex Belt & Sheave Without Grooves

**6. To install new belt, secure belt to sheave using 2 zip ties. Install zip ties in front of and behind spoke positioned at 4 o'clock.**

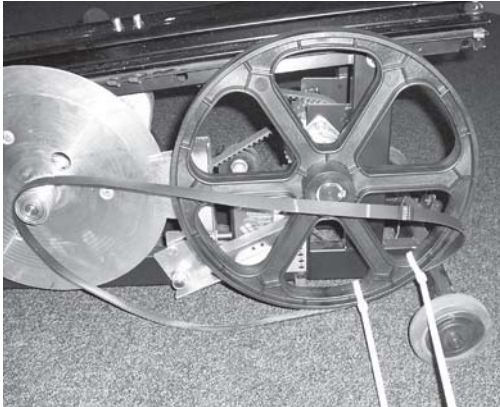

**7. Place the front of the belt onto the hub of the EC disk and rotate the sheave counter clockwise until the belt is completely on the sheave and EC disk hub.**

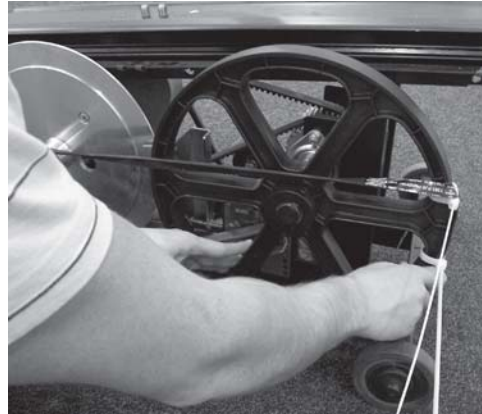

### CAUTION

Belt is under tension. To avoid injury, or damage to the product, use caution when removing or installing.

**8. Cut the zip ties off the sheave.**



**9. Spin poly-v sheave. Belt should track directly on center of sheave. If not, move poly-v sheave in or out on shaft until belt tracks true.**

*No photo.*

**10. Tighten 2 set screws of poly-v sheave securely. Install covers.**



## Rear Shaft & Timing Belt Sprockets

*NOTE: We recommend replacing both the shaft and sprockets if either wear out. For S/N  $\leq$  427184, it is necessary to replace the poly-v sheave when replacing the rear shaft.*

### Tools Required

1/8" hex key  
 1/2" socket and ratchet  
 Torque wrench

#### 1. Remove covers.

See *Cover Removal* instruction.

#### 2. Remove poly-v belt and sheave.

For S/N  $\leq$  428325, see *Poly-V Belt & Sheave* instructions.

For S/N  $\geq$  428326, see *Poly-V J6 Flex Belt & Sheave* instructions.

#### 3. For S/N $\leq$ 428173, unhook timing belt springs.

See *Timing Belt Springs* instructions.

#### For S/N $\geq$ 428174, unhook belt idler spring.

See *Flat Belt & Belt Idler Spring* instructions.



### CAUTION

To avoid injury, or damage to the product, use caution when removing or installing. Hold arm weldment when unhooking springs to prevent weldment from falling forward.

#### 4. Loosen 4 set screws on left and right side rear bearings.



#### 5. Loosen 4 nuts of bearings. Remove right bearing only.



## Rear Shaft & Timing Belt Sprockets

6. Slide rear shaft toward poly-v side and remove plastic spacers and sprockets and shaft.

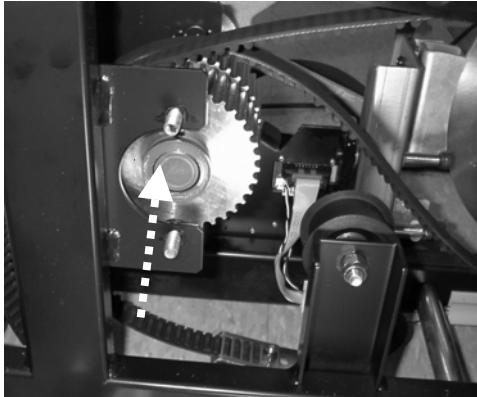

7. To install, slide new shaft from poly v side. Install parts in order: 3 spacers, sprocket, 2 spacers, sprocket, 3 spacers. See Figure 3.1.



**IMPORTANT NOTE:**

*“Lock →” and printing on roller clutches must face poly-v side. The drivetrain will not operate properly if sprockets are installed backwards.*

8. Attach right side bearing and slide shaft until shaft is flush with end of bearing. Set screws will tighten into groove on shaft.



9. Tighten 4 nuts on bearings to 200 inch-lbs.

*No photo.*

**Torque Setting:**

200 inch-lbs

10. Tighten 4 set screws; install poly-v belt and sheave; install timing belt springs (S/N  $\leq$  428173) or belt idler spring (S/N  $\geq$  428174).

## Rear Shaft & Timing Belt Sprockets

---

**Reference photos showing correct belt placement:**

**Left belt under low left idler and under load lever tube**

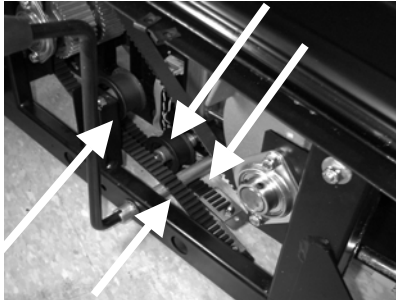

**Right belt under high right idler and over load lever tube.**

**Side view – belts in proper position and names of parts.**

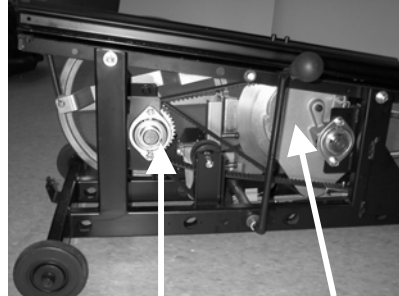

**Timing sprocket Pivot disk**

**Rear view - belts wrapped around timing sprockets.**

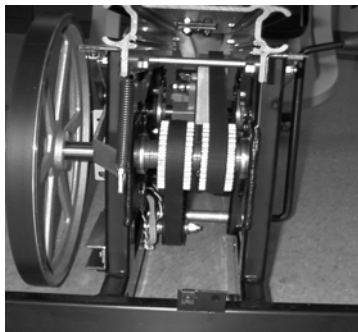

**Bottom view – belts & clamps hooked to springs and frame.**



*Note: This photo applies only to units with S/N ≤ 428173.*

**The NuStep will not work correctly without proper belt placement. If you have any questions about proper belt placement, please call us.**



## Rear Shaft Alignment

*NOTE: This instruction only applies to units with S/N < 411630 and will help prevent shaft from sliding axially in bearings. Later models have a grooved shaft.*

### Tools Required

1/8" hex key  
 Loctite 290 (wicking)  
 Rawhide hammer  
 Safety glasses

### CAUTION

To avoid injury, wear safety glasses.

**1. Remove covers.** See *Cover Removal* instruction.

**2. Loosen all 4 set screws on left and right side bearings.**



**3. Tap shaft with hammer until right end of shaft aligns with end of right side bearing (shown).**

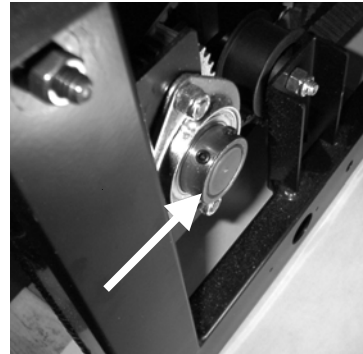

**4. Remove both right side set screws and pour a few drops of 290 Loctite down into set screw holes. Tighten all 4 set screws back down.**

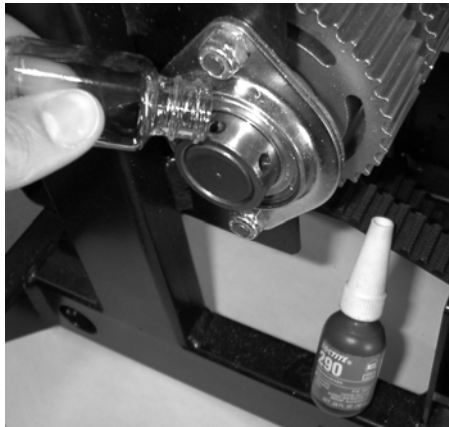

### CAUTION

To avoid injury and prevent adverse health effects, use Loctite in accordance with the manufacturer's material safety data sheets, including the use of safety glasses and impermeable gloves. Material safety data sheets are available via the internet at [www.loctite.com](http://www.loctite.com) or by calling Henkel Corporation at (800) 562-8483.

Due to Loctite strength, it is only necessary to use Loctite on right side set screws and shaft to prevent shaft from sliding axially.

**5. Moving shaft back in alignment should also align poly-v sheave and belt. If it doesn't, realign them. (See *Poly-V Belt and Sheave* instructions.) Install covers.**

## Timing Belt (R / L)

*NOTE: We recommend replacing both belts at the same time. The right side belt is an 8M20x944 mm long while the left is an 8M20x1040 mm long. Do right belt first, then left to avoid mistakes.*

### Tools Required

Phillips screwdriver (long)  
Flat head screwdriver (long)

½" socket and ratchet  
7/16" socket, ratchet, extension & wrench

**1. Remove covers.** See *Cover Removal* instructions.

**2. Remove step through support.**

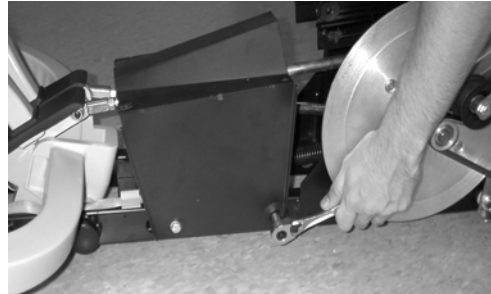

**3. For S/N ≤ 428173, unhook timing belt springs.**

See *Timing Belt Springs* instructions.

**For S/N ≥ 428174, unhook belt idler spring.**

See *Flat Belt & Belt Idler Spring* instructions.

|   |                  |
|---|------------------|
|    | <h2>CAUTION</h2> |
| <p>To avoid injury, or damage to the product, use caution when removing or installing. Hold arm weldment when unhooking springs to prevent weldment from falling forward.</p> |                  |

**4. Remove right nut and bolt using wrench and Phillips screwdriver.**

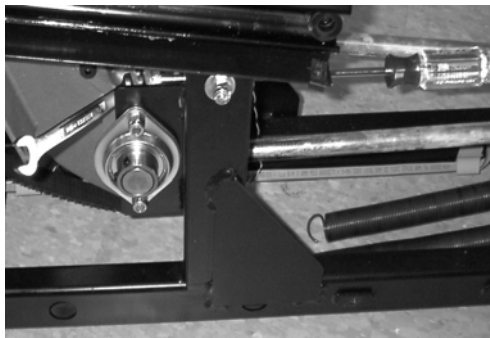

Clamp secures belt to pivot disk – 4 teeth of belt are in contact.

**5. Pry up bottom edge of clamp about ½" up to loosen belt.**

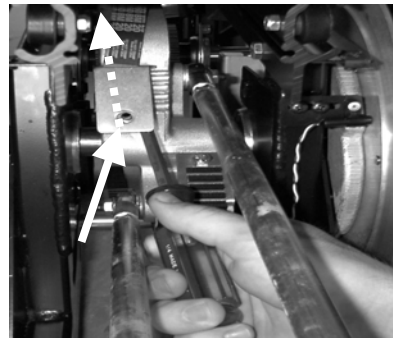

Do not bend clamp up too far, just enough to loosen belt.

## Timing Belt (R / L)

**6. With both hands, slide clamp and belt off disk, then rotate by bracket.**



R side pivot disk should be rotated rearward so that clamp can come off.

**8. Remove left nut and bolt using ratchet and wrench.**

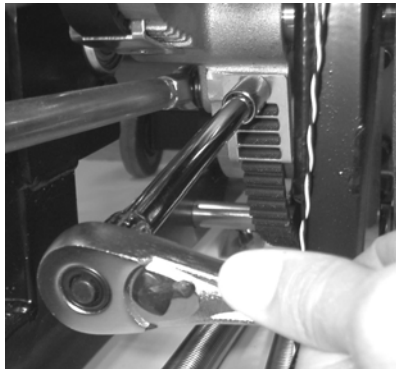

**10. Rotate clamp down and toward front to remove from pivot disk.**

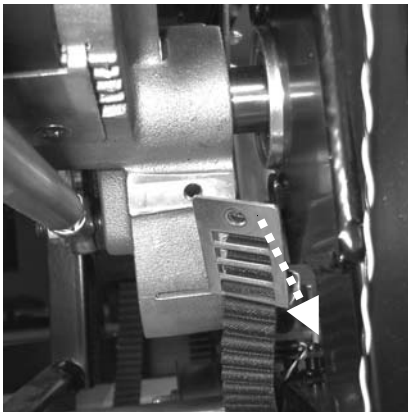

L side pivot disk should be rotated rearward to allow clamp to come off.

**7. Install new right belt by doing Steps 6, 5, 4 in reverse order.**

*See reference photos on last page.*

Installation note: some units may have a shim on the interior side of the pivot disk where the left timing belt clamp is attached. Reuse this shim when installing the new belt if applicable.

**9. Pry down top edge of clamp about 1/2" out from disk to loosen belt.**

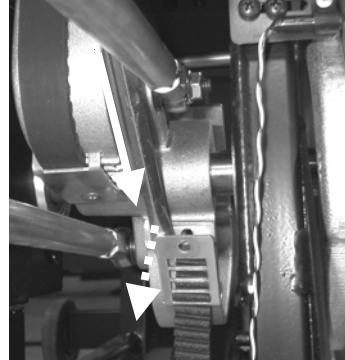

Do not bend clamp down too far, just enough to loosen belt.

**11. Install new left belt by doing Steps 10, 9, 8 in reverse order.**

*See reference photos on last page of these instructions.*

## Timing Belt (R / L)

---

**12. Remove clamps from old belts and transfer to new belts.**

**For S/N  $\leq$  428173, remove clamps that attach to timing belt springs and transfer to new belts.**

**For S/N  $\geq$  428174, remove clamps that attach to flat belt and belt idler spring and transfer to new belts.**

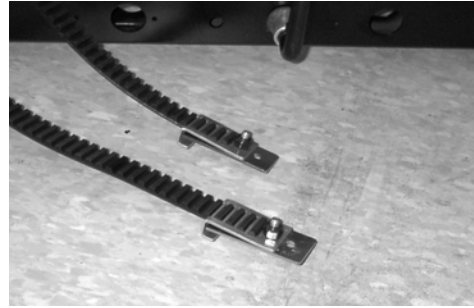

*NOTE: The clamp may be a two piece (shown) or one piece clamp.*

**13. Route belts correctly, attach timing belt springs (for S/N  $\leq$  428173) or flat belt and idler spring (for S/N  $\geq$  428174), test operation, and install covers.**

*See reference photos on next page.*

## Timing Belt (R / L)

---

### REFERENCE PHOTO OF PIVOT DISK

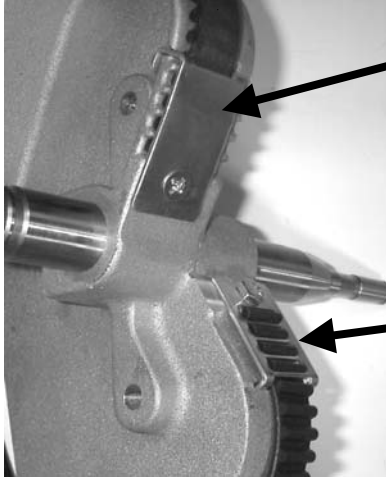

Tooth side of right belt is against pivot disk and has 4 teeth locked into teeth of casting as shown.

Backside of left belt is against pivot disk and has 4 teeth locked into slots of left clamp.

### REFERENCE PHOTOS SHOWING CORRECT BELT PLACEMENT

Left belt under low left idler and under load lever tube

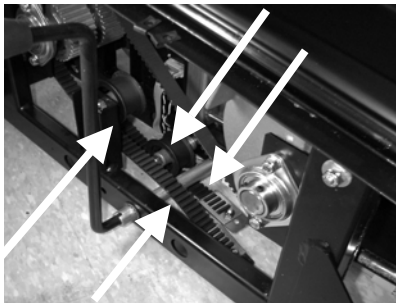

Right belt under high right idler and over load lever tube.

Side view – belts in proper position.

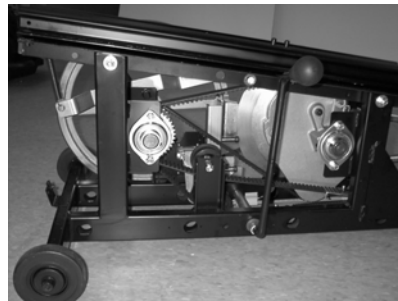

Rear view - belts wrapped around timing sprockets.

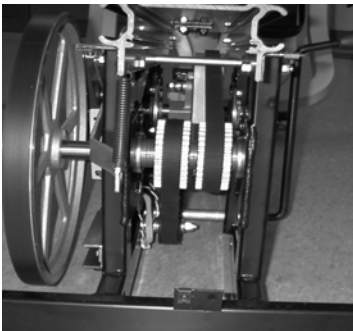

Bottom view – belts & clamps hooked to springs and frame.



*NOTE: This photo applies only to units with S/N ≤ 428173.*

## Timing Belt Springs Replacement

*NOTE: This instruction applies only to units with S/N ≤ 428173. Always replace both springs. Before replacing springs, please review how the current springs and belts are positioned on the unit, and then unhook and replace one spring at a time.*

### Tools Required

None

### 1. Turn NuStep gently onto its left side (from rider's perspective).



### ! CAUTION

The TRS 4000 is very heavy; it weighs 205 lbs (93 kg). To avoid injury, or damage to the product, always obtain assistance to move this product. Use proper lifting technique.

### 2. Carefully move arms to decrease tension on spring you are replacing.



### ! CAUTION

Springs are under tension. To avoid injury, or damage to the product, use caution when removing or installing.

Move right arm rearward (shown), to reduce tension on right spring, then replace right spring. Move left arm rearward to reduce tension on left spring, then replace it.

### 3. Review current spring and belt position, then unhook and replace one spring at a time. Keep spring hooks facing up.

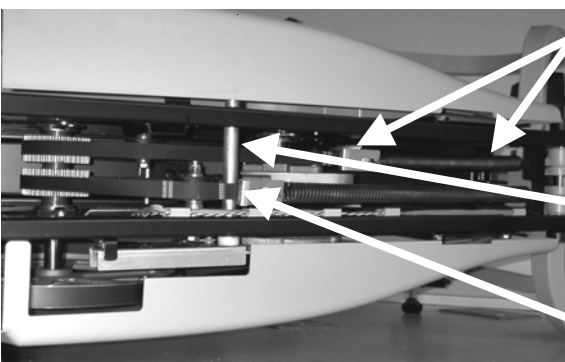

Make sure springs are hooked through rubber grommet in frame and engaged into belt clamps.

Right belt must be around higher idler and above workload lever tube.

Left belt must be around lower idler and below workload lever tube.

Make sure belts are in correct position as shown above after replacing springs.

## EC Ball Plunger Replacement / Adjustment

---

### Tools Required

Flat head screwdriver

1. Remove covers. See *Cover Removal* instruction.
2. Place workload lever in position 4.

**3. NOTE: If you are just adjusting ball plunger GOTO Step 4. If replacing, remove old one and replace with new one.**

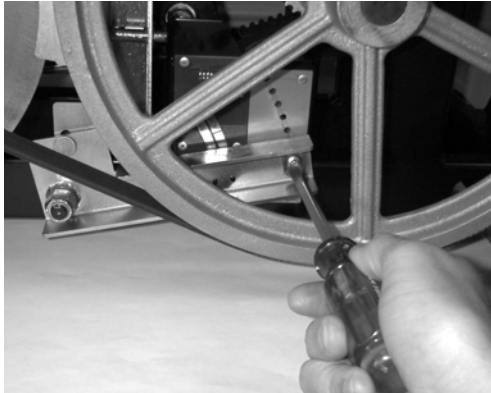

4. Tighten ball plunger until ball just seats into each hole on plate.

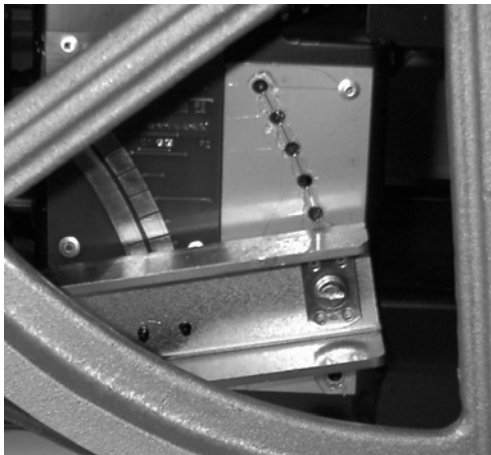

*NOTE: Move workload lever back and forth and then adjust ball plunger.*

*If workload lever is too tight (lever moves hard, and body of ball plunger scrapes plate), loosen ball plunger by turning a little to the left.*

*If workload lever is too loose (there is a little "play" in each position), tighten ball plunger by turning a little to the right. The right "feel" is achieved when the workload lever hits each position, but is not too hard to move or has excessive "play."*

5. Test that all 10 Workload Levels show on display. *No photo.*

6. Install covers. *No photo.*

## EC Disk & Bearings

*NOTE: NuStep Inc. can supply this part fully assembled, see parts list. Units with S/N 411001-411114 have only 2 bearings in the disk and a nut on the end of the shaft, while S/N  $\geq$  411115 have 3 bearings and a snap ring. This instruction applies to either.*

### Tools Required

Snap ring pliers  
 Mechanical puller (2 jaw with 4" spread and 3-1/4" reach)  
 1/2" socket and ratchet  
 2x4" blocks of wood  
 Hammer  
 Flat head screwdriver  
 9/16" deep socket

Arbor press  
 Loctite 680 (for cylindrical parts)  
 Safety glasses



### CAUTION

To avoid injury, wear safety glasses.

#### 1. Remove covers.

See *Cover Removal* instructions.

#### 2. Remove poly-v belt or poly-v J6 flex belt.

**For S/N  $\leq$  428325, remove poly-v belt.**

See *Poly-V Belt* instructions.

**For S/N  $\geq$  428326, remove poly-v J6 flex belt.**

See *Poly-V J6 Flex Belt* instructions.

#### 3. Remove belt idler arm (S/N $\leq$ 428325 only).

See *Belt Idler Arm* instructions.

**4. Remove snap ring (shown) or nut.** *NOTE: On earlier models, there is a nut instead of the snap ring.*

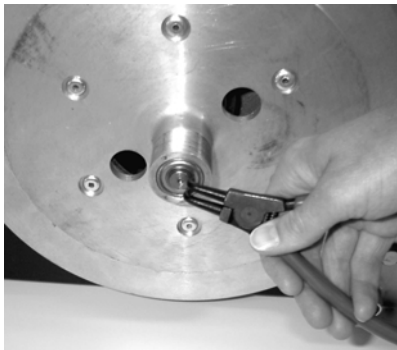

**5. Using the puller, remove disk from shaft.** *NOTE: If you are just replacing the complete EC Disk assembly, GOTO Step 10.*





## EC Disk & Bearings

**6. Remove flywheel side bearing. Bearings will be destroyed during removal. DO NOT REUSE.**

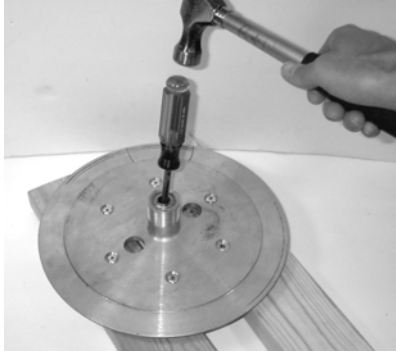

Knock out with blunt object or use arbor press to press bearing out.

**7. Remove belt side bearing(s).**

*NOTE: Early models have 1 bearing here, while later ones have 2.*

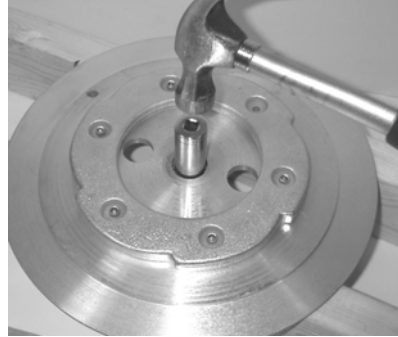

Knock out with deep socket or use arbor press to press bearings out.

**8. Clean bores on EC Disk. Place small amount of Loctite 680 on bores.**



*NOTE: Early models have 1 bearing on belt side, while most have 2 bearings (shown).*

### CAUTION

To avoid injury and prevent adverse health effects, use Loctite in accordance with the manufacturer's material safety data sheets, including the use of safety glasses and impermeable gloves. Material safety data sheets are available via the internet at [www.loctite.com](http://www.loctite.com) or by calling Henkel Corporation at (800) 562-8483.

**9. Press in bearing(s) using arbor press. Spin disk to make sure bearings are OK after installation.**

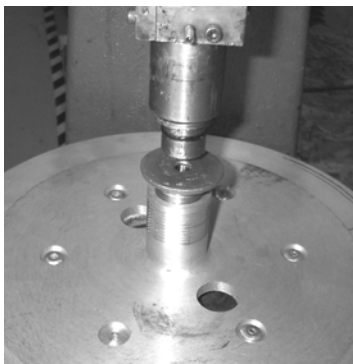

*NOTE: NuStep uses a custom bearing installation tool. However, a thick heavy washer pressing only on the bearing races can work (shown).*

## EC Disk & Bearings

---

10. Clean shaft and apply **small** amount of Loctite on shaft at 1/2 inch from the tapered end.



11. Place **small** amount of Loctite on exterior bearing race.

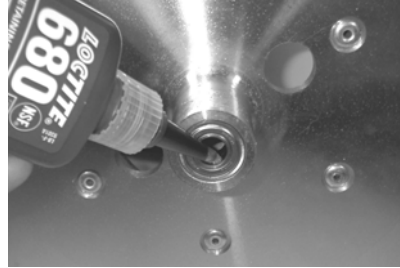

### CAUTION

To avoid injury and prevent adverse health effects, use Loctite in accordance with the manufacturer's material safety data sheets, including the use of safety glasses and impermeable gloves. Material safety data sheets are available via the internet at [www.loctite.com](http://www.loctite.com) or by calling Henkel Corporation at (800) 562-8483.

12. Carefully install EC disk onto shaft and install snap ring. Snap ring will slightly preload the bearing, and Loctite will hold disk in place.



**13. NOTE: If you are installing the nut instead of the snap ring, nut should only bottom out against shaft shoulder. Do not tighten nut so that it preloads the bearings. Spin the disk and if disk slows rapidly when tightening nut, back off so that disk spins freely instead. Any bearing preload due to the nut will shorten bearing life. Loctite will hold disk in place.**

*No photo.*

14. Install covers.

*No photo.*

## EC Magnet

*NOTE: Units with S/N  $\geq$  412485 have 3 screws and no separate bracket to attach the magnet assembly, while those with lower S/Ns have 2 screws and a separate bracket. This instruction applies to both but a lower S/N unit is shown.*

### Tools Required

Phillips screwdriver (long)

1. Remove top and left side cover. See *Cover Removal* instruction.
2. Remove 2 (or 3) screws holding magnet assembly.
3. On older models, remove screws holding this separate bracket to EC Magnet bracket (shown). On newer models there is no separate bracket.

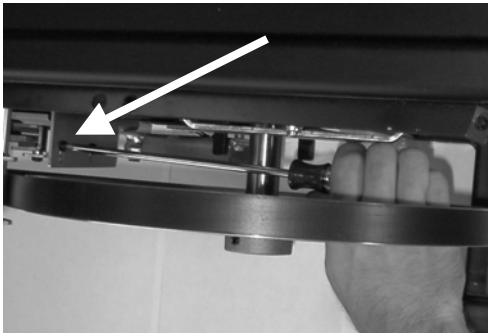

Insert screwdriver as shown. Lower magnet assembly downward and out.

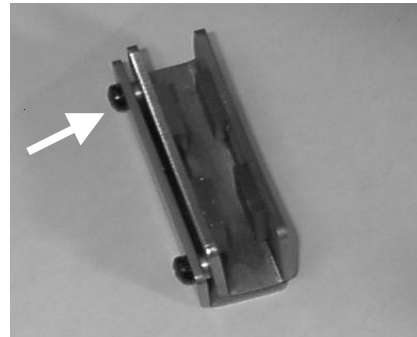

4. To install, do above steps in reverse order. Set magnet and disk gap alignment per instructions below.

5. Ride test and make sure disk does not hit magnets in all 10 loads before installing covers.

**For Gap Alignment between magnet and disk:**

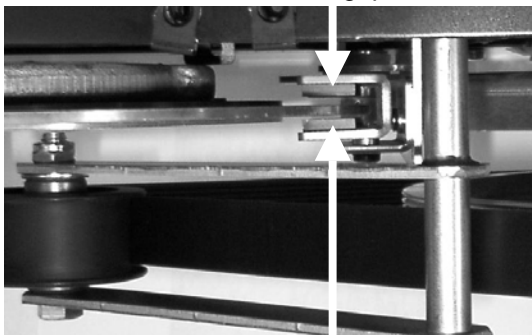

~1/8" gap this side

~1/16" gap this side

**Ride test to make sure disk does not hit magnets in all 10 loads.**

## EC Magnet Gap Alignment

---

### Tools Required

Phillips screwdriver (long)

**1. Remove top and left side cover.** See *Cover Removal* instruction.

**2. Slightly loosen 3 screws holding magnet assembly.**

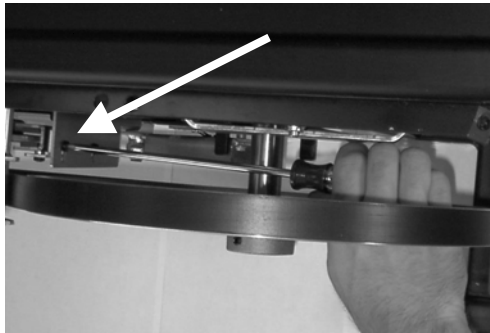

Insert long screwdriver as shown.

**3. Set gap between magnet and disk.**

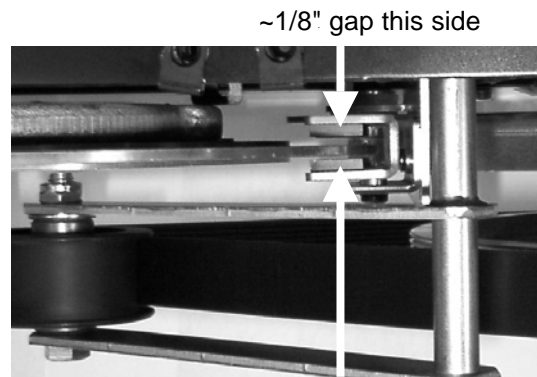

~1/16" gap this side

***Spin disk by hand to check...but do Step 4 ride test!***

**4. Ride test and make sure disk does not hit magnets in all 10 loads.**

*No photo.*

**5. Install covers.**

*No photo.*

## EC Plunger Plate & EC Magnet Slide Bracket

*NOTE: These parts come off sequentially. Once you get to the part you need to replace, replace that part and skip to the other steps as the instruction tells you.*

### Tools Required

Channel lock pliers

3/16" hex key

Silicone/grease (white or clear)

2"x4" wood

3/4" deep socket and new locking ring

Hammer

Safety glasses



### CAUTION

To avoid injury, wear safety glasses.

#### 1. Remove covers.

See *Cover Removal* instructions.

#### 2. Remove poly-v belt or poly-v J6 flex belt.

**For S/N  $\leq$  428325, remove poly-v belt.**

See *Poly-V Belt* instructions.

**For S/N  $\geq$  428326, remove poly-v J6 flex belt.**

See *Poly-V J6 Flex Belt* instructions.

#### 3. Remove load lever.

See *Load Lever* instructions.

#### 4. Remove self-locking ring. Ring will be destroyed during this step.

#### 5. Pull plunger plate out of frame.

*NOTE: if you are just replacing plunger GOTO Step 9.*

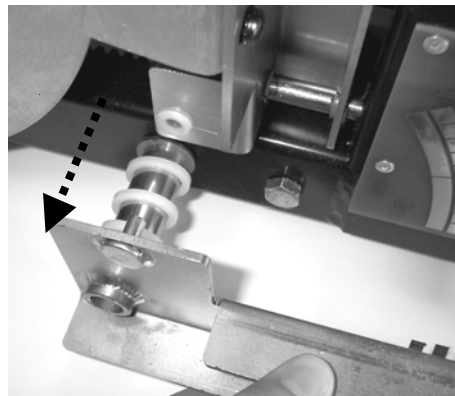

## EC Plunger Plate & EC Magnet Slide Bracket

---

**6. Remove EC magnet.**

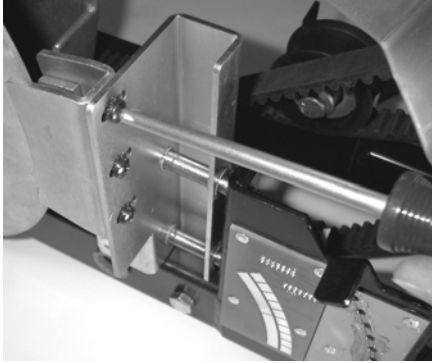

**7. Remove shoulder bolts and remove slide bracket.**



**8. Install slide bracket and lube and tighten shoulder bolts. Bracket should slide easily back and forth. If it doesn't, slightly bend shoulder bolts to make bracket slide easily on Nyliners.**

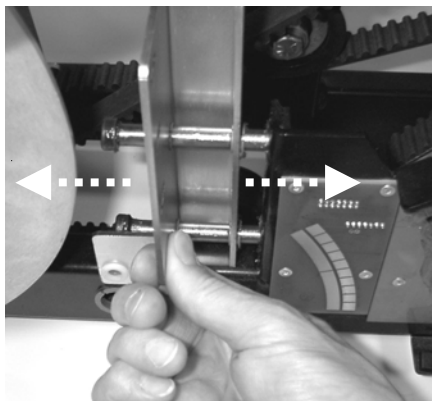

**9. Install plunger plate through Nyliners in frame. Three washers on tube, stud into shoulder washer, and ball plunger loose (not shown).**

Washers      EC Shoulder pivot

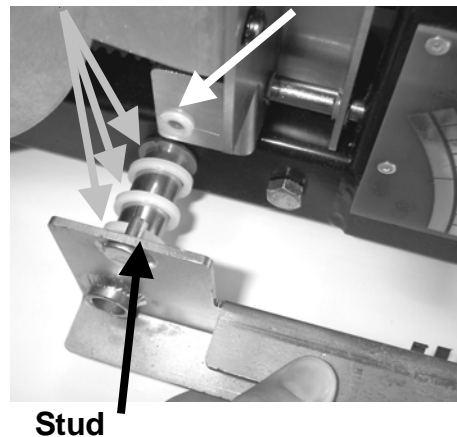

## EC Plunger Plate & EC Magnet Slide Bracket

---

**10. Leaning into a 2x4 against the plunger on left side, lean over and pound ring onto end of plunger tube with socket until it just contacts Nyliner. Make sure plunger stud does not come out of shoulder washer (see Step 9).**

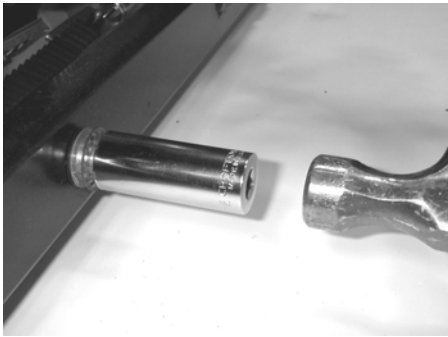

**11. Install load lever and set ball plunger.**

*See Load Lever instructions.*

*See Ball Plunger Adjustment instructions.*

*No photo.*

**12. Test. Check “Workload” on display.**

*No photo.*

**13. Install poly-v components and install covers.**

*No photo.*

## Load Lever

---

### Tools Required

3/4" socket, ratchet and extension  
 Hammer  
 Safety glasses



### CAUTION

To avoid injury, wear safety glasses.

**1. Remove covers.** See *Cover Removal* instruction.

**2. Loosen load lever nut until just a few threads are holding nut on.**



**3. Tap gently on nut to disengage load lever, then remove nut completely.**



**4. Remove load lever.**

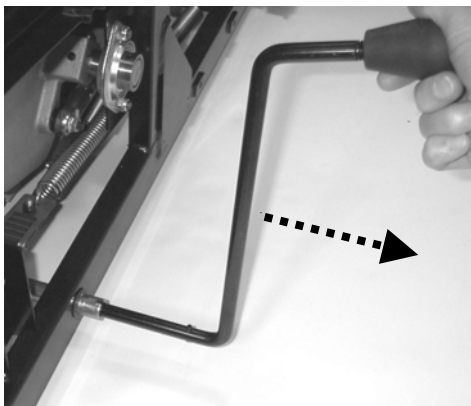

**5. Reinstall load lever and tighten nut just enough to draw roll pin into groove and remove play. Do not overtighten nut.**



**6. Check operation of load lever and “Workload” on display. Install covers.**

*No photo.*



## Workload Level PCB

### Tools Required

Scratch awl  
Hammer  
Pop rivet gun

### Parts Required

(4) 1/8" diameter by 5/16" length pop rivets  
Safety glasses

**1. Remove covers.** See *Cover Removal* instruction.

**2. Put workload lever in load 1.**

**3. Disconnect wires from back of PCB.**

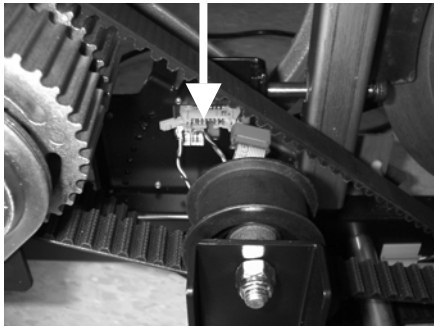

**4. From outside of frame, pound out rivets using scratch awl & hammer.**

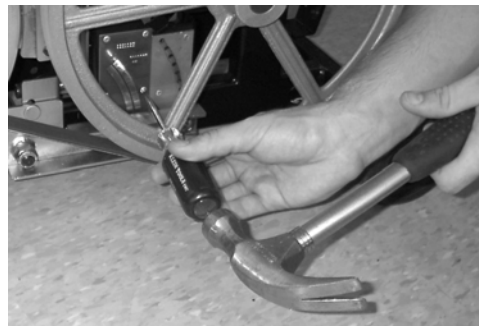

**5. Remove PCB and insulator board from frame.**

*No photo.*

**6. Carefully install new PCB and insulator board between wiper and frame using pop rivets. (see reference photo below before proceeding).**

**7. Reconnect wires shown in Step 3.**

**8. Test all electronics before installing covers.**

### Reference Photo:

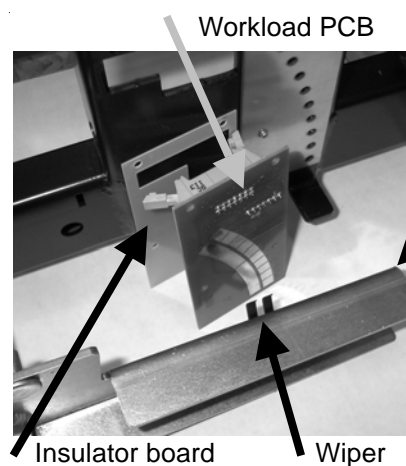

*NOTE: EC Plunger shown removed from frame for clarity. It is not necessary to remove plunger to install PCB, but you must be careful when installing PCB.*

## DC Power Cable

### Tools Required

11mm socket and wrench

**1. Gently turn NuStep onto its left side.**

**2. Remove power cable.**

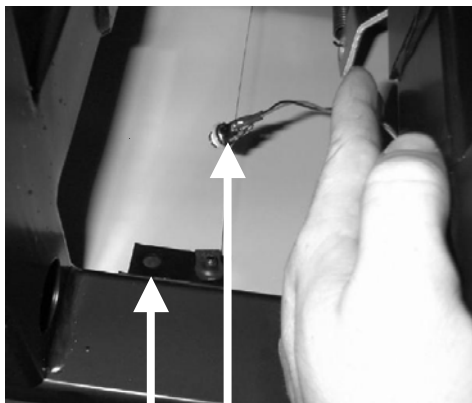

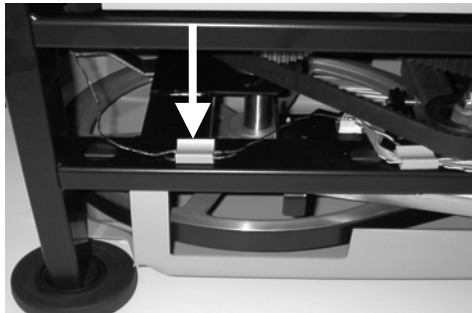

Jack hole      Power cable jack

**3. Remove wiring from clips (there may be more clips than shown).**

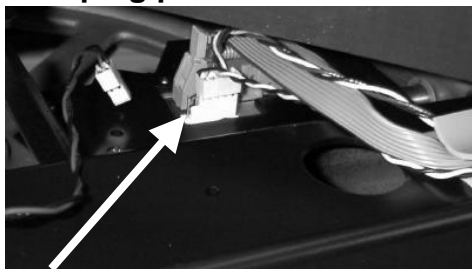

**4. Unplug power cable from board.**



|  <b>CAUTION</b>   |  |
|---|--|
| <p>The TRS 4000 is very heavy; it weighs 205 lbs (93 kg). To avoid injury, or damage to the product, always obtain assistance to move this product. Use proper lifting technique.</p> |  |

Remove nut and lockwasher with 11mm socket from the outside of the cover (not shown).

Push jack through the hole in the frame on the inside of the cover (as shown).

Unsnap connector end of power cable from connector pins on PCB board.

## DC Power Cable

---

### 5. To install, plug power cable into board.

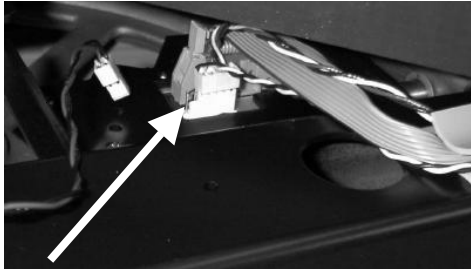

Snap connector end of power cable into connector pins on PCB board. Make sure connector is installed with cable wires exiting from the top of connector and that connector is securely snapped in place.

### 6. Prepare power cable.

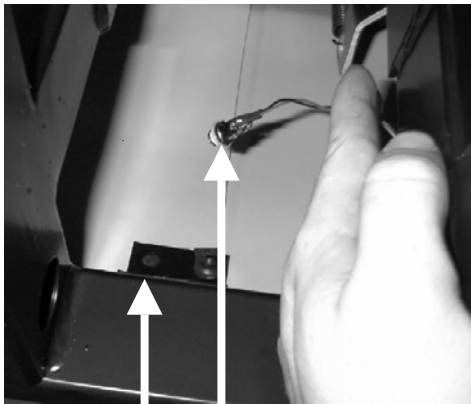

Jack hole      Power cable jack

Remove nut and lockwasher from the end of the jack. Push jack through the hole in the frame on the inside of the cover (as shown).

Now from the outside (not shown), place lockwasher and nut onto end of jack. Tighten nut with 11mm socket wrench while holding jack from inside.

### 7. Route wiring through clip(s).

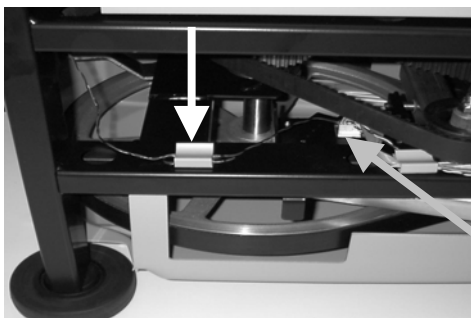

Loop extra cable back and forth and insert into a clip to keep it out of the way of moving parts.

Make sure power cable is out of the way of the ribbed timing belt.

### 8. Turn NuStep upright and test power with AC adapter.

## Hall Effect Sensor

*NOTE: This sensor and the magnet that passes by it are responsible for indicating STEPS PER MINUTE, STEPS, TIME, and for turning the display on from its sleep mode.*

### Tools Required

Phillips screwdriver (long)

**1. Remove covers.** See *Cover Removal* instruction.

**2. Disconnect ribbon cable.**

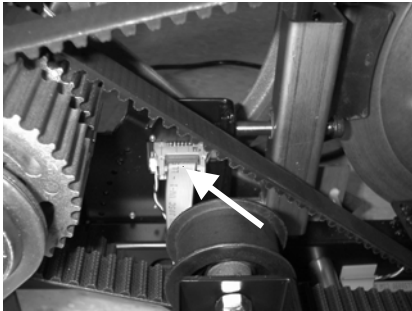

It makes it easier to access wire.

**3. Disconnect hall sensor wire.**



The red, black, & white wire on right.

**4. Unscrew sensor bracket from inside of frame.**

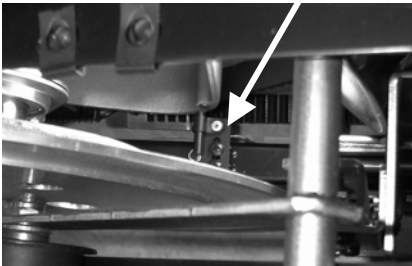

*The photo above shows the sensor bracket used for serial numbers 411001 - 422080.*

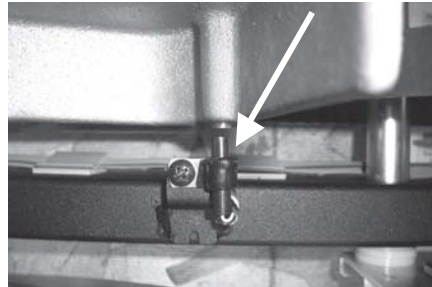

*The photo above shows the sensor bracket used for serial numbers  $\geq$  422081.*

**5. Remove sensor wiring from cable clips along frame.**

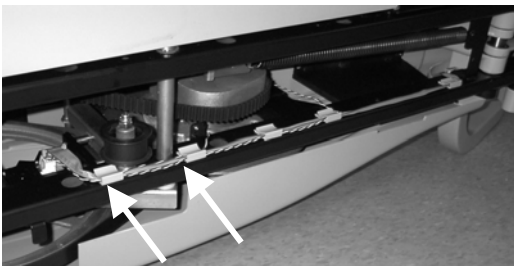

*NOTE: Bottom view shown.*

### CAUTION

The TRS 4000 is very heavy; it weighs 205 lbs (93 kg). To avoid injury, or damage to the product, always obtain assistance to move this product. Use proper lifting technique.

**6. Replace old sensor with new sensor.** *No Photo.*

## Hall Effect Sensor

---

7. To install, do above steps in reverse order. Set gap alignment.

To Set Gap Alignment:

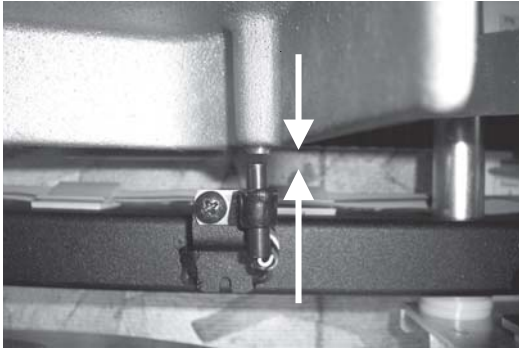

Set gap at 1/8" – 3/16" between sensor and magnet on pivot disk.

---

### Additional Installation Notes:

1. Make sure all wires are secured in cable clips on frame and out of path of timing belts.
2. Make sure wire exits from top of connector when installing into PCB connector in step 3 above.
3. Before installing covers, it's a good idea to test the sensor to make sure everything is working correctly.

## Ribbon Cable

*NOTE: This is the main cable for all electronics.*

### Tools Required

Tape



### CAUTION

The TRS 4000 is very heavy; it weighs 205 lbs (93 kg). To avoid injury, or damage to the product, always obtain assistance to move this product. Use proper lifting technique.

1. **Remove covers.** See *Cover Removal* instruction.
2. **Remove display.** (See *Display Removal* instruction.) **Keep old ribbon cable hanging out of top end of electronic tube for pulling new cable up through tube!**

### 3. Disconnect ribbon cable.

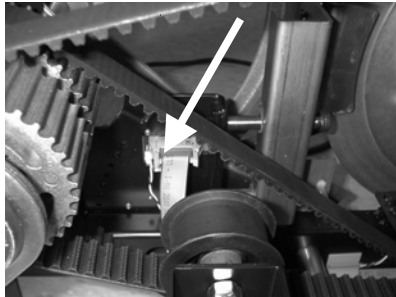

### 4. Remove ribbon cable from clips.



*Note: Bottom view shown.*

5. **Remove cable from clips, then tape new cable to end of old cable and pull it up through the electronic tube at this point.**

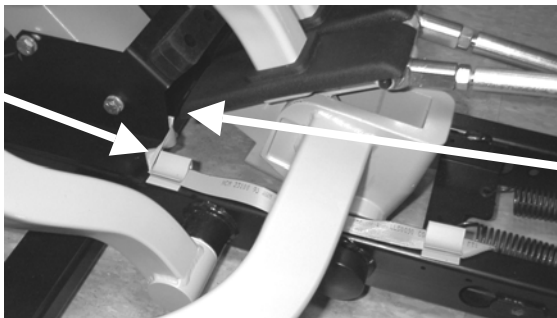

Make sure newly installed cable is out of way of pivot casting boot during operation.

Be gentle pulling cable through tube!

6. **To install remainder of lower portion of ribbon cable, do above steps in reverse order.** *No photo.*

### Additional Installation Notes:

1. Make sure all wires are secured in cable clips on frame and out of path of timing belts.
2. Make sure ribbon cable is fastened securely to board connector in step 3 above.
3. Before installing covers, it's a good idea to test the display to make sure everything is working correctly.

## VR Sensor

*NOTE: The VR sensor and the magnet that passes by it are responsible for indicating WATTS, METS, CALORIES, and TIME on the display.*

### Tools Required

Phillips screwdriver

**1. Remove covers.** See *Cover Removal* instruction.

**2. Disconnect ribbon cable.**

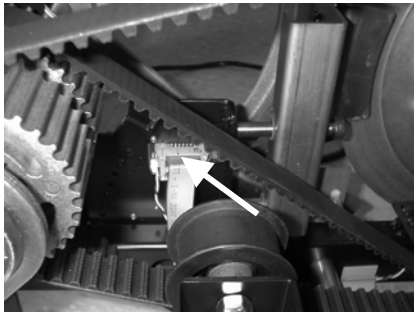

*It makes it easier to access wire.*

**3. Disconnect VR sensor wire.**

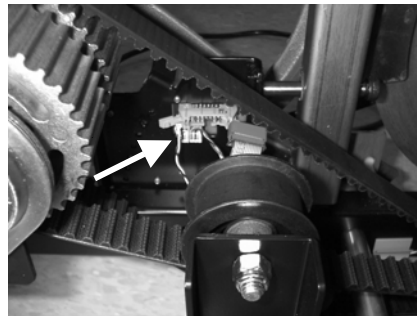

*The black & white wire on left.*

**4. Unscrew sensor bracket from frame.**

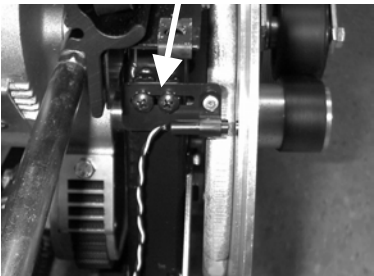

*The photo above shows the sensor bracket used for serial numbers 411001 - 422080.*

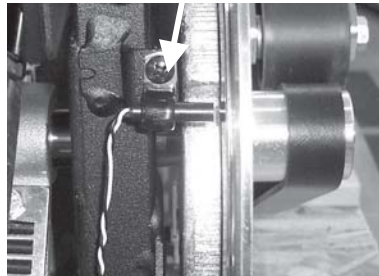

*The photo above shows the sensor bracket used for serial numbers  $\geq$  422081.*

**5. Remove sensor wiring from cable clips along frame.**

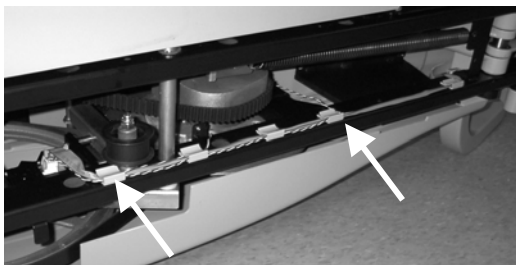

*Note: Bottom view shown.*



### CAUTION

The TRS 4000 is very heavy; it weighs 205 lbs (93 kg). To avoid injury, or damage to the product, always obtain assistance to move this product. Use proper lifting technique.

## VR Sensor

---

6. Replace old VR sensor with new sensor. *No Photo.*

7. To install, do above steps in reverse order. **Set gap alignment.**

***To Set Gap Alignment:***

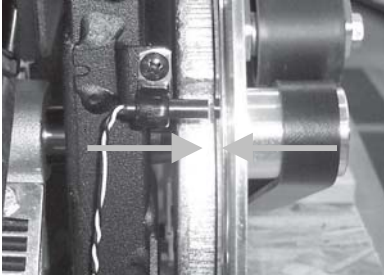

Set gap at 1/8" – 3/16" between sensor and magnet on disk.

---

### **Additional Installation Notes:**

1. Make sure all wires are secured in cable clips on frame and out of path of timing belts.
2. Make sure wire exits from top of connector when installing into PCB connector in step 3 above.
3. Before installing covers, it's a good idea to test the sensor to make sure everything is working correctly.



## Electronic Tube

---

### Tools Required

Phillips screwdriver  
 ½" wrench

Wood block  
 Torque wrench

#### 1. Remove three screws - and hold onto display so it doesn't fall!

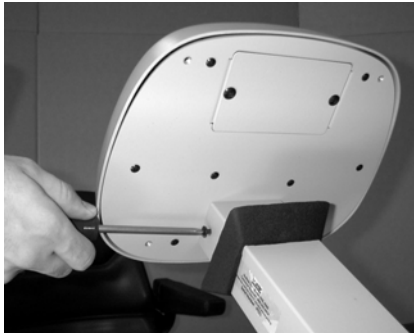

*Slide boot down tube, then remove 1 screw each side, 1 on bottom.*

#### 2. Release 2 locking tabs on each side of connector.

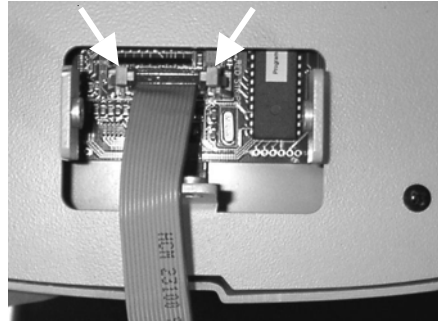

*Snap tabs of connector outward.*

#### 3. Pull out cable from connector.

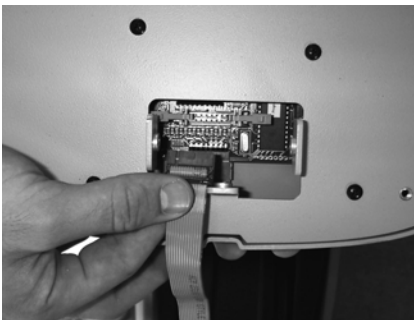

#### 4. Slide both rubber boots up and off electronic tube.

*No photo.*

#### 5. Remove 4 bolts that attach electronic tube and remove tube from frame carefully letting ribbon cable come out end.



*Remove front cover screw and carefully spread covers to access bolts.*

#### 6. To install, tie washers on end of string and drop from top through tube. Tie ribbon cable to string and carefully pull up through tube.



*String with washers attached to ribbon cable*

## Electronic Tube

---

**7. Attach tube to frame and tighten bolts to 160 in-lbs.**



**Torque Setting:**

160 inch-lbs

**8. Make sure ribbon cable is secured in clips and does not hit boot on the footpedal tube during operation.**

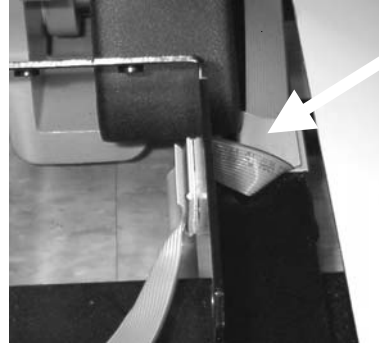

*Electronic tube and footpedal bumper removed from picture for clarity.*

**9. Slide boots onto tube, plug cable into connector and install display.**

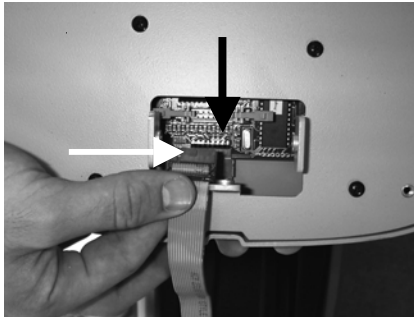

*Align key of cable with slot of connector on display.*

## Step Through Support

---

*NOTE: Removing the step through support is helpful when working on the drivetrain and especially when unhooking and hooking timing belt springs to remove tension on the drivetrain.*

### Tools Required

½" socket and ratchet

**1. Remove covers.** See *Cover Removal* instruction.

**2. Remove step through support.**

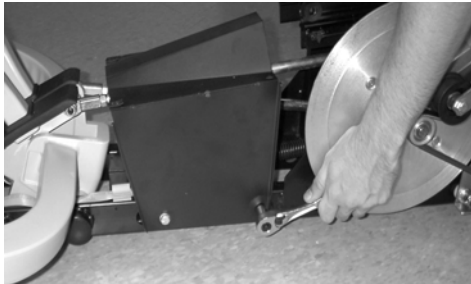

*One piece step through support shown above applies to serial numbers 411001 - 423601.*



*Two piece step through support shown above applies to serial numbers  $\geq$  423602.*

**3. To install, do above steps in reverse order.** *No photo.*

## Wheel & Axle

### Tools Required

2 blocks of wood  
Channel lock pliers  
Rubber hammer  
Safety glasses

### Parts Required

3/8" pushnut(s)

## CAUTION

The TRS 4000 is very heavy; it weighs 205 lbs (93 kg). To avoid injury, or damage to the product, always obtain assistance to move this product. Use proper lifting technique.

**1. Prop rear of NuStep on block of wood and remove pushnut with pliers.**



*Pushnut will be destroyed during removal.*

**2. Remove wheel(s) and/or axle.**



**3. To install, place wheels and axle back on and balance pushnut onto end of axle. Hold block of wood gently against pushnut on opposite side. With one direct hit, hit pushnut on. Continue to hit pushnut on until there are slight gaps between pushnuts and wheels on both ends.**



*Do not hit pushnut on too tight as damage may occur and/or wheels may not roll.*

## CAUTION

To avoid injury, wear safety glasses.

## Footpedal 1999 (R or L)

*Note: This only applies to units with serial numbers of 411001 – 413367. For serial numbers  $\geq 413368$  see Footpedal 2000 instructions. You may want to remove both lower retaining rings from the footpedal tubes to reduce operating tension. See Retaining Ring Removal instructions.*

### Tools Required

Snap ring pliers - 90° tip  
 Rubber mallet  
 Quick clamp (maybe)  
 Safety glasses

### CAUTION

The TRS 4000 is very heavy; it weighs 205 lbs (93 kg). To avoid injury, or damage to the product, always obtain assistance to move this product. Use proper lifting technique.

### CAUTION

To avoid injury, wear safety glasses.

**1. Turn NuStep gently onto the side that you want to remove the footpedal from (left side is shown).**



**2. Remove lower retaining ring from footpedal support tube inside frame.**



This ring may already be removed.

**3. With NuStep upright, remove upper retaining ring near footpedal.**



**4. With equal pressure, pull/pound tube out of frame and footpedal.**



Arm must be all the way forward.

## Footpedal 1999 (R or L)

---

**5. Remove upper footpedal retaining ring and remove footpedal.**



**6. To install, continue by sliding footpedal onto shaft.**

*No photo.*

**7. Install upper footpedal retaining ring. Lock ring in place.**



**8. Install tube, push/pound with equal pressure at top and bottom.**



If hard to insert, a quick clamp (shown) usually works better than the mallet.

**9. Install upper ring to secure tube to footpedal.**



To reduce operating tension, do not install lower retaining ring on footpedal tube. Remove opposite side lower ring also.

## Footpedal 2000 (R or L)

*Note: This only applies to units with serial numbers  $\geq$  413368. For serial numbers 411001 – 413367, see Footpedal 1999 instructions. Left side instructions are shown.*

### Tools Required

3/16" hex key

1/2" wrench

Snap ring pliers - 90° tip

Loctite 242

Large flat head screwdriver

Safety glasses



### CAUTION

To avoid injury, wear safety glasses.

### 1. Remove upper nut from stabilizer. Prevent shoulder bolt from turning.



*Shoulder bolt is locked to footpedal. Don't turn it. If it loosens, then Loctite it back in during installation below.*

### 2. Pry rod end off shoulder bolt with large flat head screwdriver.



### 3. Remove upper footpedal retaining ring and remove footpedal.



## Footpedal 2000 (R or L)

**4. To install, slide footpedal onto shaft.**

*No photo.*

**5. Install upper footpedal retaining ring. Lock ring in place.**



**6. Place a little Loctite 242 onto shaft and threads of shoulder bolt. Don't let any get into rod end ball.**



*If upper shoulder bolt loosened in Step 1, place a little Loctite on shoulder bolt shaft and install into footpedal.*

### CAUTION

To avoid injury and prevent adverse health effects, use Loctite in accordance with the manufacturer's material safety data sheets, including the use of safety glasses and impermeable gloves. Material safety data sheets are available via the internet at [www.loctite.com](http://www.loctite.com) or by calling Henkel Corporation at (800) 562-8483.

**7. Tighten nut securely. Prevent shoulder bolt from turning.**



**8. On both rod ends, wipe grease on both sides of rod end into spaces between rod end and washer and rod end and nut / bolt.**

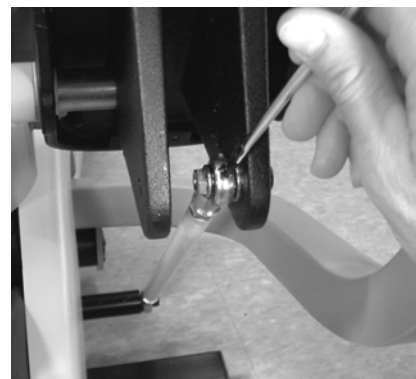



## Footpedal Bearing Replacement

*NOTE: NuStep Inc. can supply the bearings inserted into a new footpedal, see Parts List. Units with S/Ns 411001-413367 have Footpedal 1999 with 4 bearings total, while S/Ns  $\geq$  413368 have Footpedal 2000 with 2 bearings total. This instruction shows Footpedal 2000. We recommend using an arbor press to insert bearings. If you don't have one, use the wood technique below.*

### Tools Required

Large flat head screwdriver  
 Hammer  
 Blocks of wood  
 Safety glasses



**CAUTION**

To avoid injury, wear safety glasses.

**1. Remove footpedal.** See *Footpedal 1999* or *Footpedal 2000* instructions.

**2. Insert screwdriver against end of bearing wall and gently tap out. Be careful not to scar footpedal bore.**



**3. To insert outside bearing(s), carefully tap into bore using a block of wood and hammer.**



*Make sure bearing goes in equally, and does not get skewed.*

**4. To insert inside bearing(s), use wood to press bearing into bore with downward pressure.**

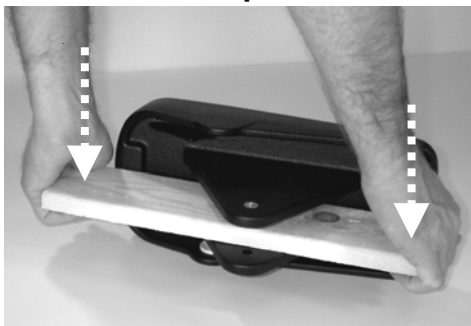

*Make sure bearing presses in equally, and does not get skewed.*

**5. Install footpedal.**

*No photo.*

## Footpedal Bumper Upgrade

---

### Tools Required

Phillips screwdriver (long and/or magnetic preferred)

**1. Remove (2) screws and current bumper and discard.**

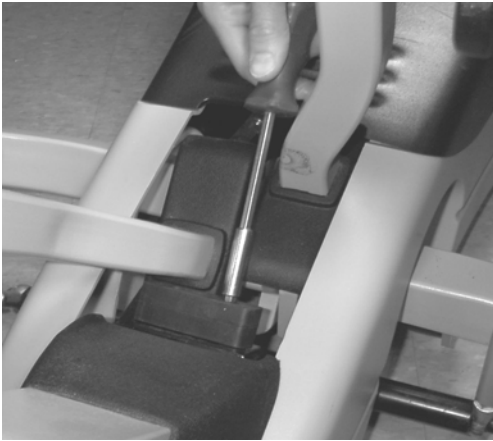

*Push right footpedal forward to remove left screw, left footpedal forward to remove right screw or center footpedals and remove both screws.*

**2. Align new bracket over existing holes and install (2) new flat head fasteners and tighten.**

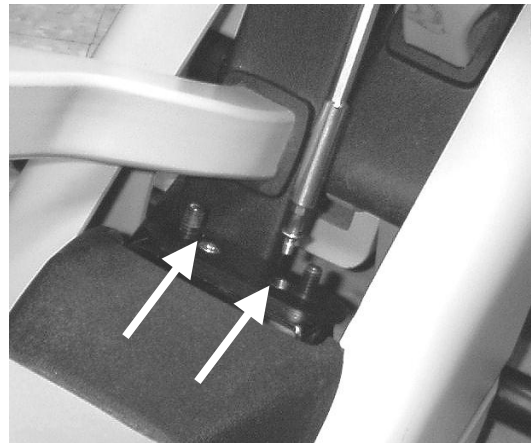

**3. Install new bumpers onto the footpedal bumper bracket and tighten snugly with finger pressure.**



## Footpedal Stabilizer 2000 (R or L)

*Note: This only applies to units with serial numbers  $\geq$  413368. For serial numbers 411001 – 413367, see Footpedal Support Tube 1999 instructions. Left side instructions are shown.*

### Tools Required

3/16" hex key  
 1/2" wrench  
 Snap ring pliers  
 Loctite 242  
 Large flat head screwdriver  
 Hammer  
 Grease/silicone (white or clear preferred)  
 Torque wrench  
 Safety glasses



### CAUTION

To avoid injury, wear safety glasses.

### 1. Remove upper nut from stabilizer. Prevent shoulder bolt from turning.



*Shoulder bolt is locked to footpedal. Don't turn it. If it loosens, then Loctite it back in during installation below.*

### 2. Remove lower shoulder bolt from frame.



*Shoulder bolt is locked to rod end ball. Remove rod end from shoulder bolt by lightly tapping with a hammer.*

## Footpedal Stabilizer 2000 (R or L)

3. Pry upper rod end off shoulder bolt with large flat head screwdriver.



4. To install, place a little Loctite 242 onto shaft and threads of shoulder bolt and tighten to 200 in-lbs. Don't get any Loctite into rod end ball.



### Torque Setting:

200 inch-lbs

### CAUTION

To avoid injury and prevent adverse health effects, use Loctite in accordance with the manufacturer's material safety data sheets, including the use of safety glasses and impermeable gloves. Material safety data sheets are available via the internet at [www.loctite.com](http://www.loctite.com) or by calling Henkel Corporation at (800) 562-8483.

5. Place a little Loctite 242 onto shaft and threads of shoulder bolt. Don't let any get into rod end ball.



*If upper shoulder bolt loosened in Step 1, place a little Loctite on shoulder bolt shaft and install into footpedal.*

## Footpedal Stabilizer 2000 (R or L)

---

**6. Tighten nut securely. Prevent shoulder bolt from turning.**



**7. On both rod ends, wipe grease on both sides of rod end into spaces between rod end and washer and rod end and nut / bolt.**

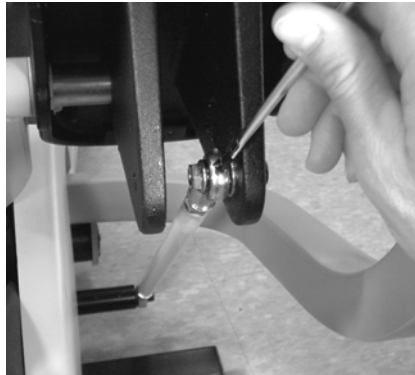

## Footpedal Support Tube 1999 (R or L)

*Note: This only applies to units with serial numbers of 411001 – 413367. For s/n >413367 see Footpedal Stabilizer instructions. You may want to remove both lower retaining rings from the footpedal tubes to reduce operating tension. See Retaining Ring Removal instructions.*

### Tools Required

Snap ring pliers

Safety glasses

Quick clamp (maybe)

### CAUTION

The TRS 4000 is very heavy; it weighs 205 lbs (93 kg). To avoid injury, or damage to the product, always obtain assistance to move this product. Use proper lifting technique.

### CAUTION

To avoid injury, wear safety glasses.

**1. Turn NuStep gently onto the side that you want to remove the tube from (left side is shown).**



**2. Remove lower retaining ring from footpedal support tube inside frame.**



This ring may already be removed.

**3. With NuStep upright, remove upper retaining ring near footpedal.**



**4. With equal pressure, pull tube out of frame and footpedal.**



## Footpedal Support Tube 1999 (R or L)

---

**5. To install tube, push with equal pressure at top and bottom.**



If hard to insert, use quick clamp (shown) at top and bottom.

**6. Install upper ring to secure tube to footpedal. Lock ring in place.**



Do not install lower retaining ring.  
Remove opposite lower ring also.

## Footpedal Support Tube Retaining Ring Removal

*Note: This only applies to units with serial numbers of 411001 – 411943. Removing both lower retaining rings helps reduce the overall operating tension of the NuStep. After removal, there may be a slight gap between the footpedal support tube and the frame, and this is normal.*

### Tools Required

Snap ring pliers

Safety glasses (for removing ring)

### CAUTION

The TRS 4000 is very heavy; it weighs 205 lbs (93 kg). To avoid injury, or damage to the product, always obtain assistance to move this product. Use proper lifting technique.

### CAUTION

To avoid injury, wear safety glasses.

**1. Turn NuStep gently onto its left side (from rider's perspective).**



**2. Remove lower retaining ring from left footpedal support tube inside frame. Do not remove upper ring near footpedal!**

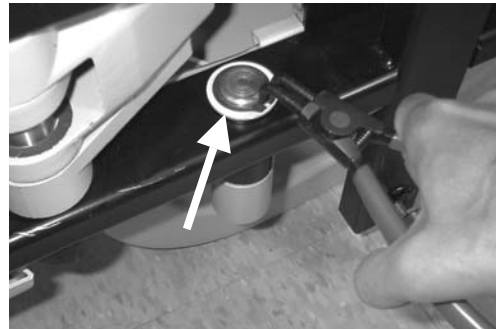

*Note: After removing the ring, the shaft may snap into the frame and there may now be a gap on the outside between the tube and the frame. This is normal.*

**3. Turn NuStep gently onto its right side.**

*No photo.*

**4. Remove lower retaining ring from right footpedal support tube inside frame. Do not remove upper ring near footpedal!**

*No photo.*



## Seat & Swivel & Seat Channel

**NOTE: Follow "NOTE" and "GOTO" instructions carefully. They tell what Steps to do and what to skip for specific parts.**

### Tools Required

5/32" hex key  
 Needle nosed pliers  
 1/2" socket and ratchet  
 Long socket extension  
 1/2" wrench  
 7/16" socket and ratchet  
 Torque wrench  
 242 Loctite  
 Silicone or white grease



### CAUTION

To avoid injury, and to ensure safe operation of this product, fasteners must be tightened to the proper torque.

**1. Remove seat assembly.** See *Seat Assembly Removal* instructions.

**2. Remove seat release bracket.**

For S/N  $\leq$  428341, see *Seat Release Bracket* instructions.

For S/N  $\geq$  428342, see *Seat Release Bracket With Stud* instructions.

**3. Swivel seat channel assembly 45° to access four bolts that attach seat channel to seat.**

**4. Remove four bolts and washers.**

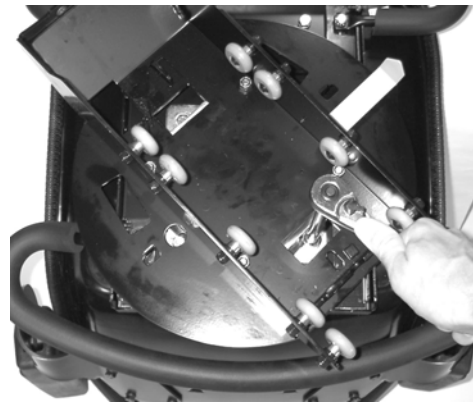
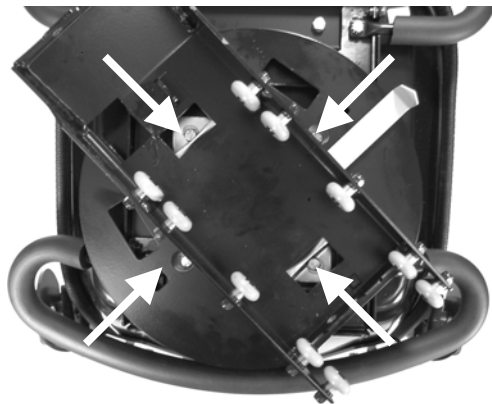

## Seat & Swivel & Seat Channel

**5. Lift seat channel assembly off.**  
**NOTE: If you are replacing the seat channel or swivel, GOTO Step 10.**



**6. Remove seat mounting bracket.**  
 Remove front two bolts below and lift assembly off seat.



**7. Replace seat.** Lubricate seat bottom lightly where it contacts mounting bracket (see old seat). Transfer armrests to new seat.



*Lubrication prevents squeaking between the two parts.*

**8. Position springs with larger diameter coil against seat.** Install mounting bracket over both springs. Springs go through holes in bracket.

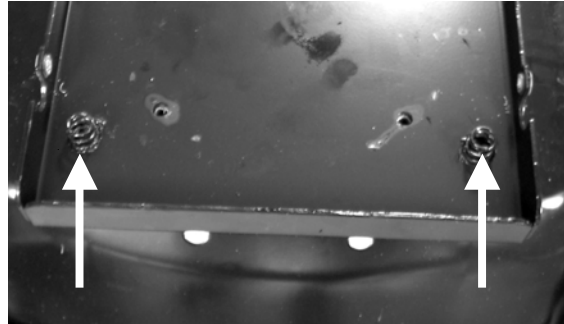

*Springs shown in holes (other parts removed for clarity).*

**9. Align 6 mounting holes, install front two bolts, tighten to 200 in-lbs.**  
**GOTO Step 13 if you are done.**



*Make sure springs operate properly.*

**10. Remove four bolts that attach swivel to channel.**

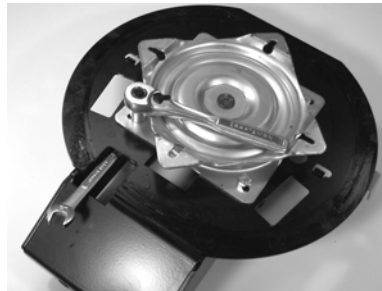

### Torque Setting:

200 inch-lbs

## Seat & Swivel & Seat Channel

---

11. Replace swivel now (not shown). Replace seat channel now. Transfer wheels from old channel to new. Tighten bolts to 80 in-lbs.

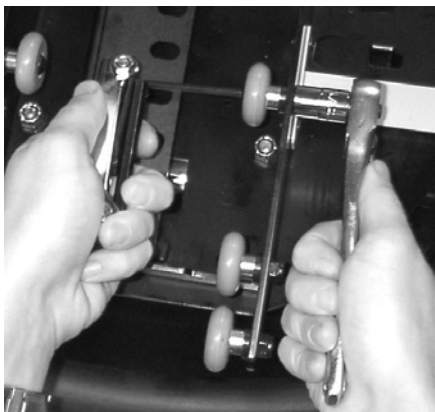

**Torque Setting:**

80 inch-lbs

12. Install swivel with keyhole slots against seat bottom. Tighten bolts to 200 in-lbs. Lubricate round flat area on channel (see old channel).

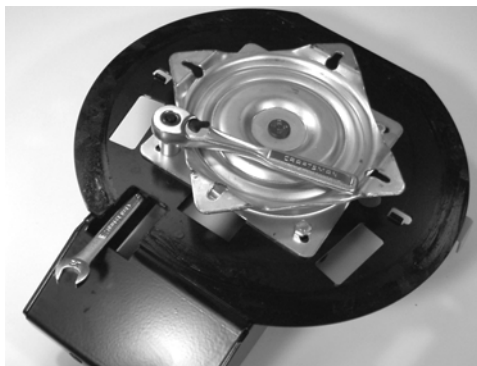

**Torque Setting:**

200 inch-lbs

13. To install seat channel, place Loctite on swivel bolts.



### CAUTION

To avoid injury and prevent adverse health effects, use Loctite in accordance with the manufacturer's material safety data sheets, including the use of safety glasses and impermeable gloves. Material safety data sheets are available via the internet at [www.loctite.com](http://www.loctite.com) or by calling Henkel Corporation at (800) 562-8483.

## Seat & Swivel & Seat Channel

---

**14. Swivel assembly 45° to install two bolts through cutouts.**

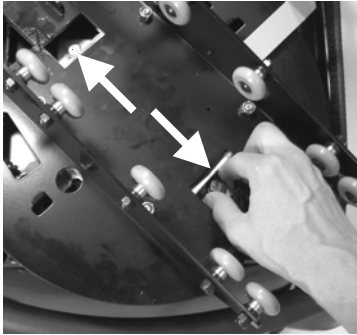

**15. Swivel assembly 90° to install next two bolts through cutouts.**

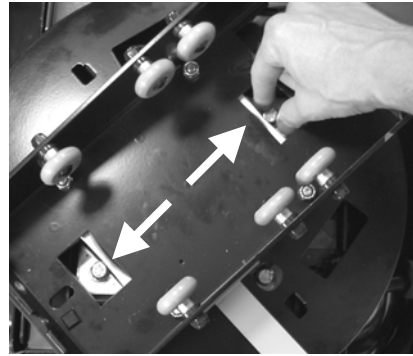

**16. Tighten all four bolts to 200 in-lbs.**

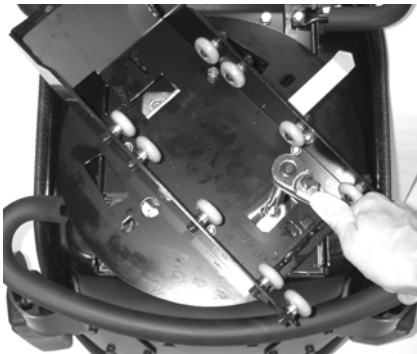

**17. Check swivel and release lever operation.**



**Torque Setting:**

200 inch-lbs

**18. Install seat release bracket.**

For S/N  $\leq$  428341, see *Seat Release Bracket* instructions.

For S/N  $\geq$  428342, see *Seat Release Bracket With Stud* instructions.

**19. Test seat locking operation. Install seat assembly onto NuStep.**

## Seat Armrest (R / L) & Seat Armrest Bracket (R / L)

### Tools Required

1/2" socket and ratchet

9/16" socket

9/16" wrench

**1. Remove three bolts that attach bracket to seat (left side shown).**

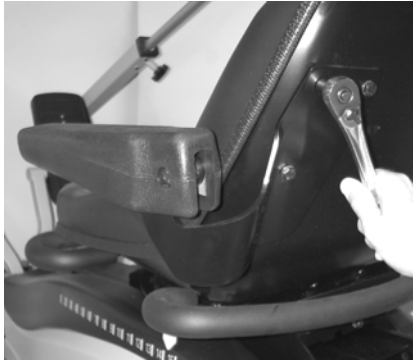

**2. Remove bolt that attaches armrest to armrest bracket.**



**3. Replace armrest or armrest bracket at this time. No photo**

**4. To install, spacers go on each side of bracket inside armrest. Slide bolt through from outside in.**



**5. Tighten nut until armrest moves smoothly but not too tight or loose.**



Compare feel with other side armrest and match it.

**6. Attach bolts that hold armrest and tighten to 200 in-lbs.**



|  |
|--|
|  <b>CAUTION</b>               |
| To avoid injury, and to ensure safe operation of this product, fasteners must be tightened to the proper torque. |

|                        |
|------------------------|
| <b>Torque Setting:</b> |
| 200 inch-lbs           |

## Seat Assembly Removal / Installation

**NOTE:** These instructions are usually the first step if you have to work on or replace the seat assembly.

### Tools Required

Phillips screwdriver

3/8" wrench

## CAUTION

The TRS 4000 seat assembly is heavy; it weighs 50 lbs (23 kg). To avoid injury or damage to the product, use caution when removing or installing. Obtain assistance as required. Use proper lifting technique.

### 1. Remove seat rail cap.



### 2. Remove seat rail bumpers.



### 3. Roll seat off of seat rail.



Keep upward pressure on front of seat to prevent scratching end of seat rail.

### 4. If you are going to work on the seat, turn seat upside down and lay it across rear of NuStep.



The horizontal position keeps parts from sliding out of position.

### 5. To install, do steps in reverse order. No photo.

## Seat Locking Upgrade

*NOTE: This instruction applies to units with S/N < 428343.*

### Tools Required

7/16" socket and ratchet  
 7/16" wrench  
 Drill  
 Shop vac  
 Long socket extension  
 Philips screwdriver  
 1/2" or 15/32" drill bit  
 Safety glasses



**CAUTION**

To avoid injury, wear safety glasses.

1. **Remove seat assembly.** See *Seat Assembly Removal* instruction.
2. **Replace seat release bracket.** See *Seat Release Bracket With Stud* instruction.
3. **Remove covers.** See *Cover Removal* instruction.
4. **Remove old seat stop pin weldment and discard screws.**

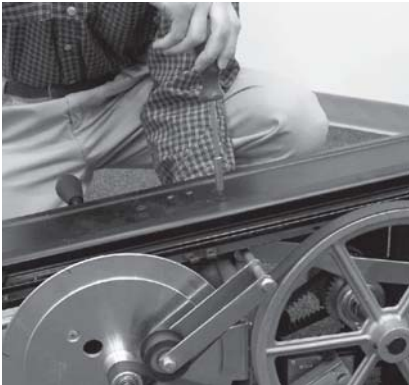

5. **Enlarge 2 seat stop pin holes on seat rail and remove all metal shavings from the unit after drilling.**



## Seat Locking Upgrade

---

### 6. Install new seat stop pin weldment using new screws.



*Note: install seat stop pin weldment with notch toward the front of the unit.*

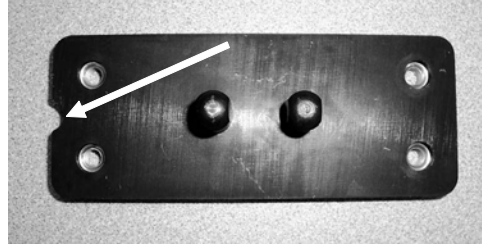

### 7. Install covers and seat assembly. See *Cover Removal* instruction.



## Seat Mounting Bracket Assembly

---

### Tools Required

5/32" hex key  
 Needle nosed pliers  
 1/2" socket and ratchet  
 Long socket extension  
 7/16" socket and ratchet  
 Torque wrench  
 242 Loctite



### CAUTION

To avoid injury, and to ensure safe operation of this product, fasteners must be tightened to the proper torque.

**1. Remove seat assembly.** See *Seat Assembly Removal* instructions.

**2. Remove seat release bracket.**

For S/N  $\leq$  428341, see *Seat Release Bracket* instructions.

For S/N  $\geq$  428342, see *Seat Release Bracket With Stud* instructions.

**3. Swivel seat channel assembly 45° to access four bolts that attach seat channel to seat.** **4. Remove four bolts and washers.**

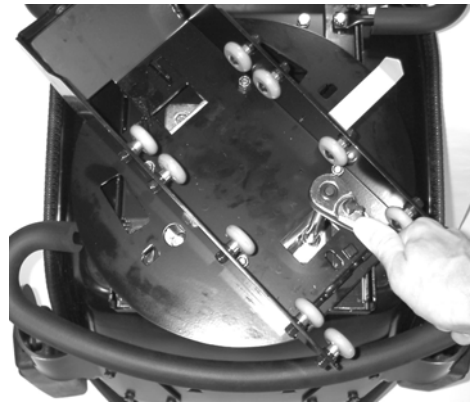
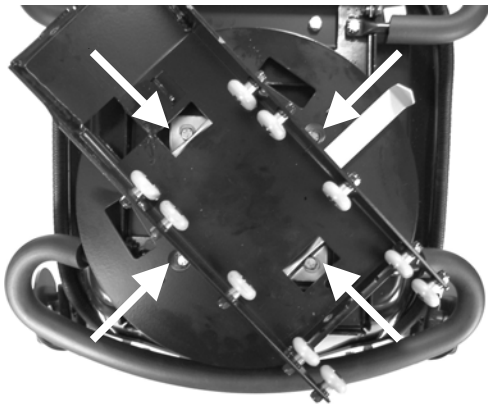

## Seat Mounting Bracket Assembly

**5. Lift seat channel assembly off. Remove seat release lever and swivel release lever.**



**6. Remove the two remaining bolts that attach seat mounting bracket to seat and remove seat mounting bracket.**



*Note: leave rear seat lever springs in place on seat bottom.*

**7. Align holes of new seat mounting bracket assembly with seat weldnuts and rear seat lever springs. Place bracket on seat and thread two bolts with lockwashers into front weldnuts. Tighten bolts to 200 in-lbs.**



**Torque Setting:**

200 inch-lbs

**8. Transfer old swivel release lever to new bracket and tighten nuts to 80 in-lbs.**



**Torque Setting:**

80 inch-lbs

## Seat Mounting Bracket Assembly

---

10. Transfer old seat release lever to new bracket and tighten nuts to 80 in-lbs.



### Torque Setting:

80 inch-lbs

11. To install seat channel, place Loctite on swivel bolts.



### ! CAUTION

To avoid injury and prevent adverse health effects, use Loctite in accordance with the manufacturer's material safety data sheets, including the use of safety glasses and impermeable gloves. Material safety data sheets are available via the internet at [www.loctite.com](http://www.loctite.com) or by calling Henkel Corporation at (800) 562-8483.

12. Swivel assembly 45° to install two bolts through cutouts.

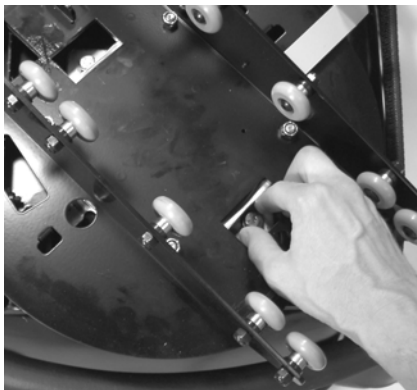

## Seat Mounting Bracket Assembly

---

**13. Swivel assembly 90° to install next two bolts through cutouts.**

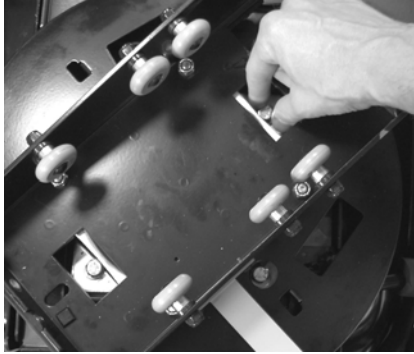

**14. Tighten all four bolts to 200 in-lbs.**

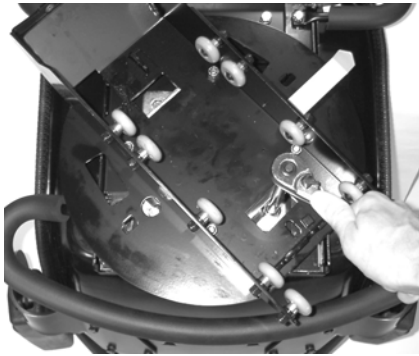

**Torque Setting:**

200 inch-lbs



**CAUTION**

To avoid injury, and to ensure safe operation of this product, fasteners must be tightened to the proper torque.

**15. Check swivel lever operation. Swivel seat left and right and check that swivel locks in place.**



**16. Install seat release bracket.**

For S/N  $\leq$  428341, see *Seat Release Bracket* instructions.

For S/N  $\geq$  428342, see *Seat Release Bracket With Stud* instructions.

**17. Check seat locking operation. Install seat assembly onto NuStep.**  
See *Seat Assembly Removal* instructions.

## Seat Mounting Bracket & Seat Release Lever Bracket & Swivel Release Lever Bracket & Springs & Nyliners

### Tools Required

5/32" hex key  
 Needle nosed pliers  
 1/2" socket and ratchet  
 Long socket extension  
 7/16" socket and ratchet  
 Torque wrench  
 242 Loctite  
 Safety glasses

### CAUTION

To avoid injury, wear safety glasses.

### CAUTION

To avoid injury, and to ensure safe operation of this product, fasteners must be tightened to the proper torque.

**1. Remove seat assembly.** See *Seat Assembly Removal* instructions.

**2. Remove seat release bracket.**

For S/N  $\leq$  428341, see *Seat Release Bracket* instructions.

For S/N  $\geq$  428342, see *Seat Release Bracket With Stud* instructions.

**3. Swivel seat channel assembly 45° to access four bolts that attach seat channel to seat.**

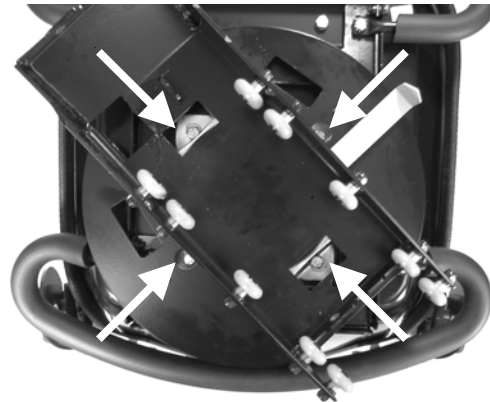

**4. Remove four bolts and washers.**

**5. Lift seat channel assembly off.**  
**NOTE:** To remove swivel release lever bracket or springs or Nyliners, GOTO Step 6. To remove seat release lever bracket or springs or Nyliners, GOTO Step 9.

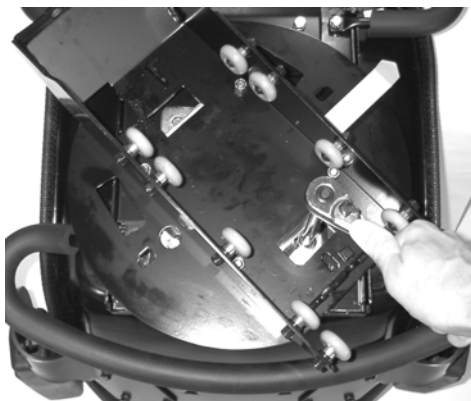

**Seat Mounting Bracket & Seat Release Lever Bracket & Swivel Release Lever Bracket & Springs & Nyliners**

**6. Remove shoulder bolts and remove swivel release lever bracket assembly.**

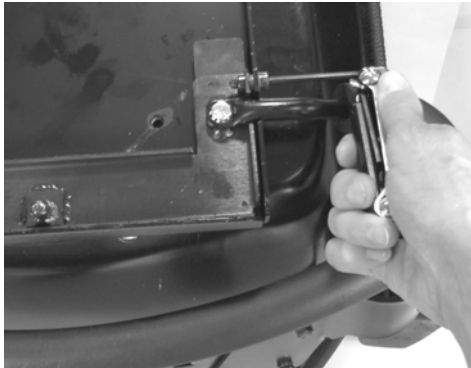

**7. Replace springs or Nyliners now. Lubricate and install springs with larger diameter coil against seat (in holes). *If only replacing springs or Nyliners, GOTO Step 12.***

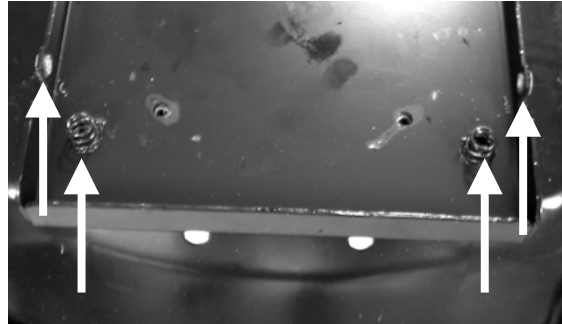

Insert Nyliners with large flange out.

**8. Transfer old lever to new bracket. Place Loctite on bolts if applicable. Tighten bolts or nuts to 80 in-lbs. GOTO Step 12.**

*Note: for S/N ≤ 415411 the lever is attached with bolts. For S/N ≥ 415412, the lever is attached with nuts.*

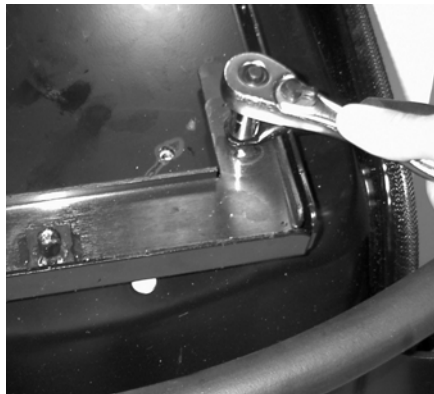

|   |
|---|
|  <b>CAUTION</b>  |
| To avoid injury and prevent adverse health effects, use Loctite in accordance with the manufacturer's material safety data sheets, including the use of safety glasses and impermeable gloves. Material safety data sheets are available via the internet at <a href="http://www.loctite.com">www.loctite.com</a> or by calling Henkel Corporation at (800) 562-8483. |

|                        |
|------------------------|
| <b>Torque Setting:</b> |
| 80 inch-lbs            |

## Seat Mounting Bracket & Seat Release Lever Bracket & Swivel Release Lever Bracket & Springs & Nyliners

9. Remove shoulder bolts and remove seat release lever bracket assembly.



10. Replace spring or Nyliners now. **NOTE: If only replacing springs or Nyliners, GOTO Step 12.**



*Insert Nyliners with large flange out.*

### CAUTION

Springs are under tension. To avoid injury, or damage to the product, use caution when removing or installing.

11. Transfer old lever to new bracket. Place Loctite on bolts if applicable. Tighten bolts or nuts to 80 in-lbs.

*Note:*

*For S/N  $\leq$  415411 the lever is attached with bolts.*

*For S/N  $\geq$  415412, the lever is attached with nuts.*



### CAUTION

To avoid injury and prevent adverse health effects, use Loctite in accordance with the manufacturer's material safety data sheets, including the use of safety glasses and impermeable gloves. Material safety data sheets are available via the internet at [www.loctite.com](http://www.loctite.com) or by calling Henkel Corporation at (800) 562-8483.

### Torque Setting:

80 inch-lbs

## Seat Mounting Bracket & Seat Release Lever Bracket & Swivel Release Lever Bracket & Springs & Nyliners

**12. To install either release bracket, place Loctite on shoulder bolts.**



*Don't get Loctite on Nyliners.*

**13. Tighten all shoulder bolts to 80 in-lbs. (swivel bracket shown).**



**Torque Setting:**

80 inch-lbs

**14. To install seat channel, place Loctite on swivel bolts.**



**15. Swivel assembly 45° to install two bolts through cutouts.**

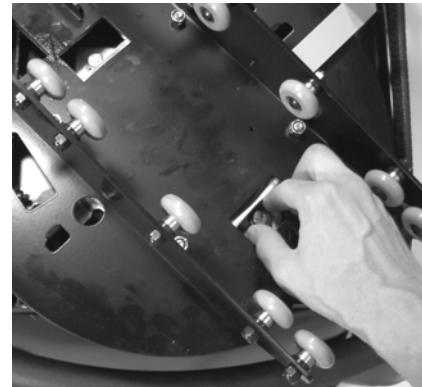



## Seat Mounting Bracket & Seat Release Lever Bracket & Swivel Release Lever Bracket & Springs & Nyliners

**16. Swivel assembly 90° to install next two bolts through cutouts.**

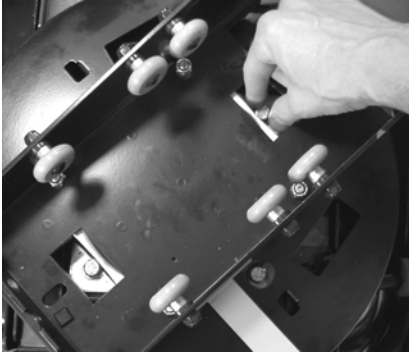

**17. Tighten all four bolts to 200 in-lbs.**

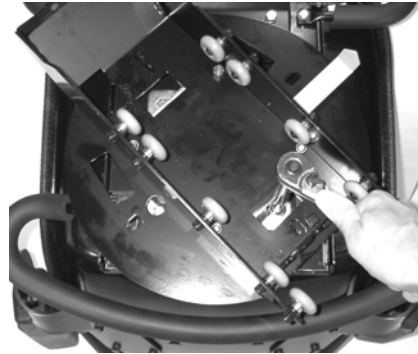

**Torque Setting:**

200 inch-lbs

**18. Check swivel and release lever operation. Swivel seat left and right and check that swivel locks in place.**



**19. Install seat release bracket.**

For S/N  $\leq$  428341, see *Seat Release Bracket* instructions.

For S/N  $\geq$  428342, see *Seat Release Bracket With Stud* instructions.

**20. Check seat locking operation.**

**Install seat assembly onto NuStep.**

See *Seat Assembly Removal* instructions.

## Seat Position Indicator

---

### Tools Required

Phillips screwdriver (long and magnetic if possible)

1. Roll seat back to position 15.
2. Remove 2 screws holding seat position indicator.

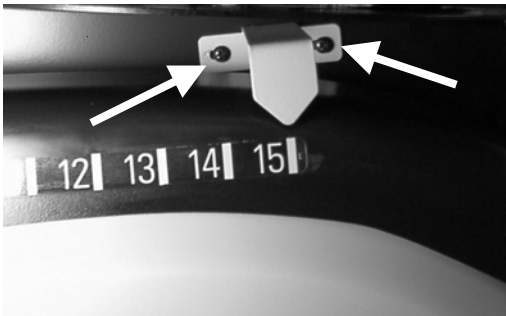

3. To install, place indicator in position and tighten screws just to hold indicator in position.

4. Make sure seat is locked in position 15. Shift indicator left or right to align point with bar stripe, then fully tighten screws.

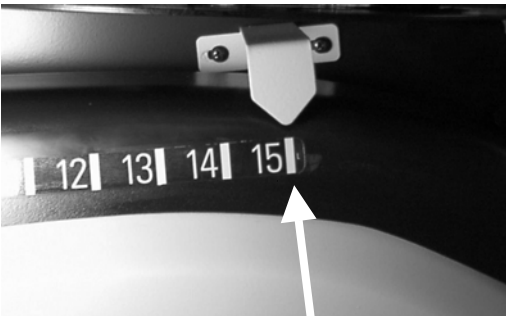

## Seat Rail & Seat Stop Pin & Angle Cover Mount Bracket

### Tools Required

½" socket and ratchet

Large Phillips screwdriver

7/16" socket and ratchet and extension

**1. Remove covers.** See *Cover Removal* instructions.

**2. Remove poly-v belt and spring.**

For S/N ≤ 428325, see *Poly-V Belt* instructions.

For S/N ≥ 428326, see *Poly-V J6 Flex Belt* instructions.

**3. Remove (4) bolts, washers and nuts that attach seat rail to frame.**



**4. Lift seat rail off of frame.**

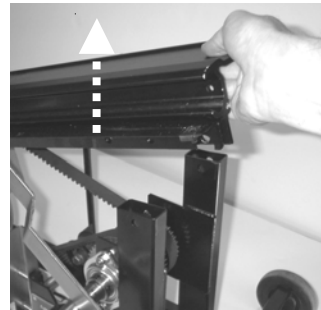

**5. To replace seat stop pin, remove (4) bolts. Install new seat stop pin weldment using new screws. GOTO step 8 if replacing seat stop pin only.**

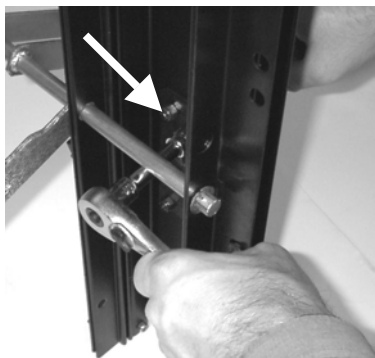

### Reference Photo:

*Note: install seat stop pin weldment with notch toward the front of the unit.*

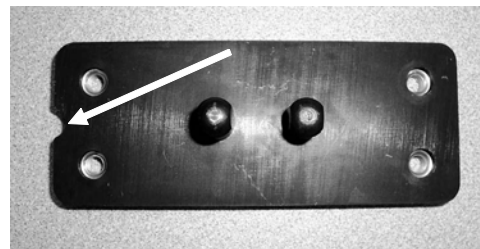

**6. To replace seat rail or angle cover mount brackets, remove belt idler arm from seat rail assembly.** See *Belt Idler Arm* instructions.

*No photo.*

## Seat Rail & Seat Stop Pin & Angle Cover Mount Bracket

**7. Replace applicable parts and transfer old parts to new.**

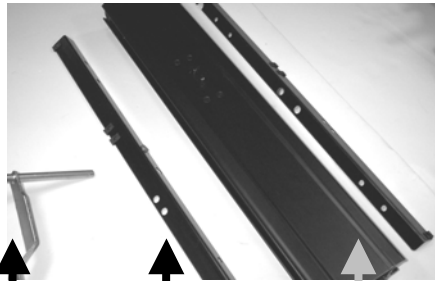

↑ Idler arm    ↑ Bracket(2)    ↑ Seat Rail

**8. Install seat rail onto frame.  
Tighten nuts securely. Install covers.**



## Seat Release Bracket & Seat Release Spring & Nyliners

*NOTE: This instruction applies to units with S/N ≤ 428341.*

### Tools Required

5/32" hex key  
 Needle nosed pliers  
 Torque wrench  
 242 Loctite  
 Silicone or white grease  
 Safety glasses

### CAUTION

To avoid injury, wear safety glasses.

### CAUTION

To avoid injury, and to ensure safe operation of this product, fasteners must be tightened to the proper torque.

**1. Remove seat assembly.** See *Seat Assembly Removal* instructions.

**2. Remove seat release bracket by removing front and rear shoulder bolts (rear shown).**

**3. Remove seat release spring.**

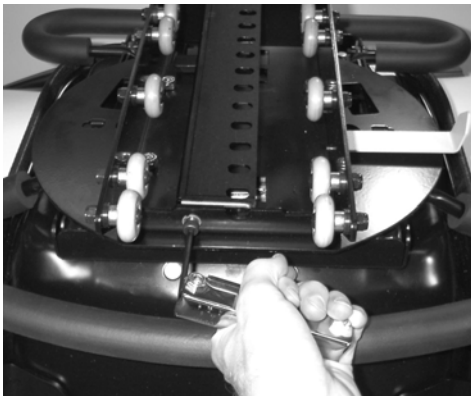

### CAUTION

Springs are under tension. To avoid injury, or damage to the product, use caution when removing or installing.

**4. Replace seat release bracket or spring or Nyliners now (not shown). Before installing, lubricate bracket along slots and where lever pin contacts bracket (see old bracket).**

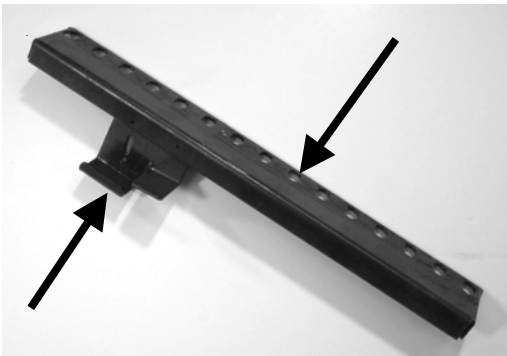

## Seat Release Bracket & Seat Release Spring & Nyliners

### 5. Install seat release bracket. Loctite front and rear shoulder bolt threads.



*Don't get Loctite on Nyliners.*



### CAUTION

To avoid injury and prevent adverse health effects, use Loctite in accordance with the manufacturer's material safety data sheets, including the use of safety glasses and impermeable gloves. Material safety data sheets are available via the internet at [www.loctite.com](http://www.loctite.com) or by calling Henkel Corporation at (800) 562-8483.

### 6. On front, wave washer goes on shoulder bolt (peak against bolt head), washer on inside of channel.

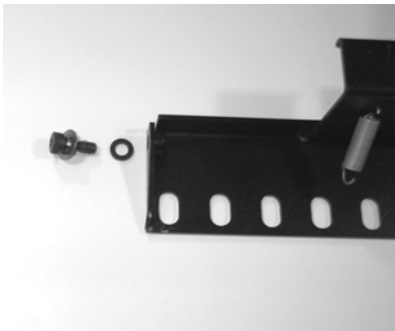

*NOTE: If your model does not have a wave washer, install without.*

### 7. On rear, washer goes on inside of channel. Tighten both shoulder bolts to 80 in-lbs.

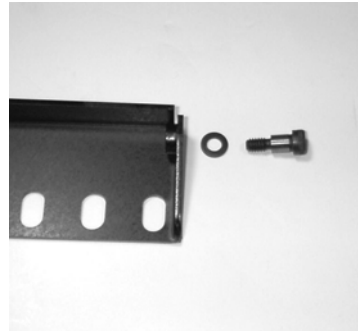

*NOTE: The shoulder bolt may extend out from end of Nyliner.*

### Torque Setting:

80 inch-lbs

### 8. Install spring.



### 9. Test seat locking operation. Install seat assembly onto NuStep. See *Seat Assembly Removal* instructions.

## Seat Release Bracket With Stud & Seat Release Spring

*NOTE: This instruction applies to units with S/N  $\geq$  428342.*

### Tools Required

5/32" hex key

1/2" socket and ratchet

Silicone or white grease

Needle nosed pliers

Phillips screwdriver

Safety glasses



### CAUTION

To avoid injury, wear safety glasses.

1. Remove seat assembly. See *Seat Assembly Removal* instructions.
2. Remove seat release bracket by removing front locknut, front flange bearing, and rear shoulder bolt (keep rear washer and bolt).

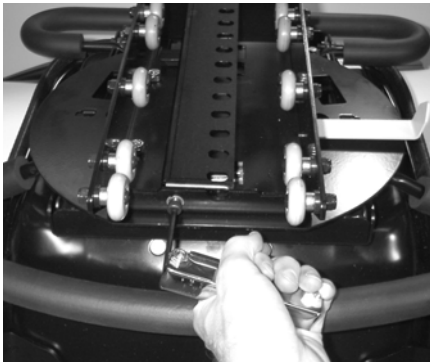

3. Remove and keep seat release spring.



4. Remove old thrust washer from seat release bracket.



### CAUTION

Springs are under tension. To avoid injury, or damage to the product, use caution when removing or installing.

## Seat Release Bracket With Stud & Seat Release Spring

---

**5. Lubricate new seat release bracket along slots (on bottom) and on tab (on top) where the lever pin contacts the bracket (see old bracket).**

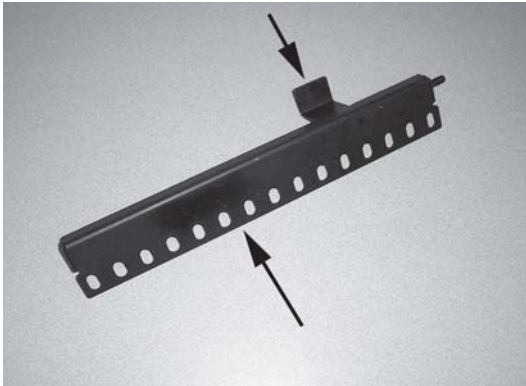

**6. Place thrust washer on bracket stud.**



**7. Slide bracket stud into the front seat channel hole.**

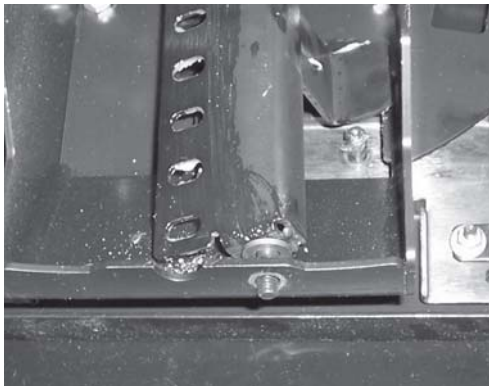

**8. Slide flange bearing onto bracket stud and ensure that the bearing slides inside the thrust washer.**

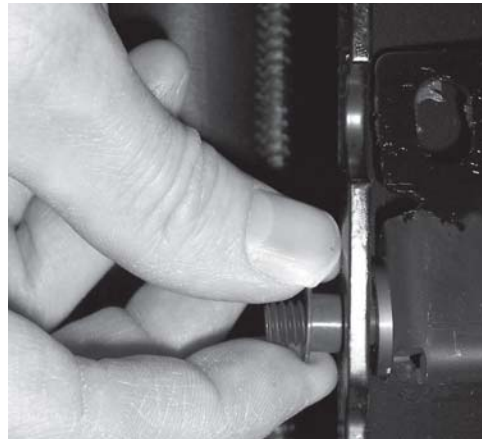



## Seat Release Bracket With Stud & Seat Release Spring

**9. Thread locknut onto stud, but do not tighten nut yet.**



**10. Install spring.**

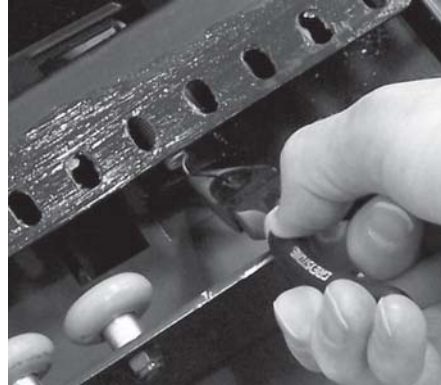

**11. Slide shoulder bolt through rear seat channel hole and washer; thread bolt into bracket and tighten to 80 in-lbs.**

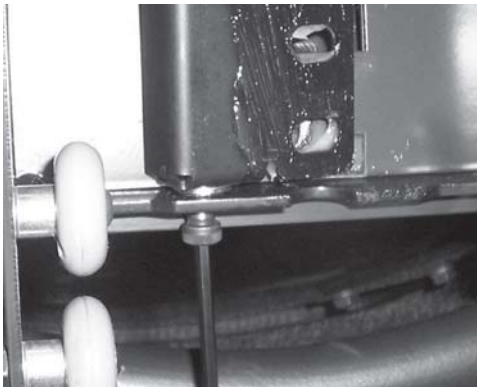

**Torque Setting:**

80 inch-lbs

## Seat Release Bracket With Stud & Seat Release Spring

---

**12. Tighten front locknut until the bracket is tight, and then back off until the bracket rotates freely from the pull of the spring.**

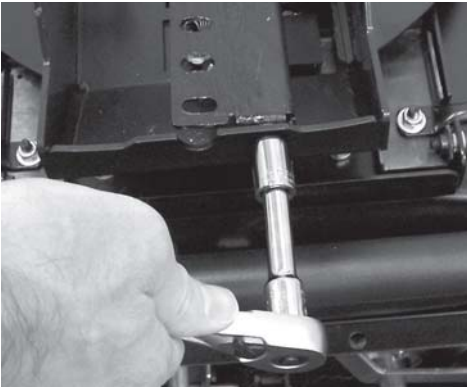

**13. Test seat release bracket operation by depressing the seat release lever.**



**14. Install seat assembly on NuStep.**

See *Seat Assembly Removal* instructions.

## Seat Release Lever

**NOTE:** Follow Steps 1, 2, & 4 if you are only tightening the bolts that hold this lever.

### Tools Required

7/16" socket and ratchet

242 Loctite

Torque wrench

### 1. Swivel seat to the side and locate two bolts.

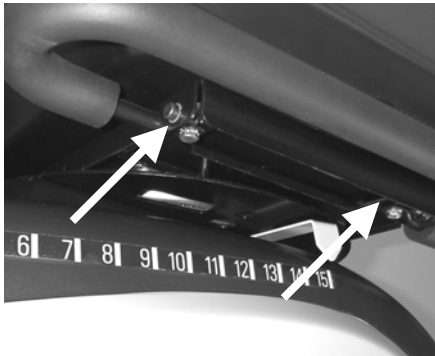

### 2. Remove bolts and lockwashers from bracket.



### 3. Remove lever.



## Seat Release Lever

4. To install, do steps in reverse order. Place Loctite on both bolts before installing them, then tighten to 80 in-lbs.



### CAUTION

To avoid injury, and to ensure safe operation of this product, fasteners must be tightened to the proper torque.

### Torque Setting:

80 inch-lbs

### CAUTION

To avoid injury and prevent adverse health effects, use Loctite in accordance with the manufacturer's material safety data sheets, including the use of safety glasses and impermeable gloves. Material safety data sheets are available via the internet at [www.loctite.com](http://www.loctite.com) or by calling Henkel Corporation at (800) 562-8483.

### REFERENCE PHOTO:

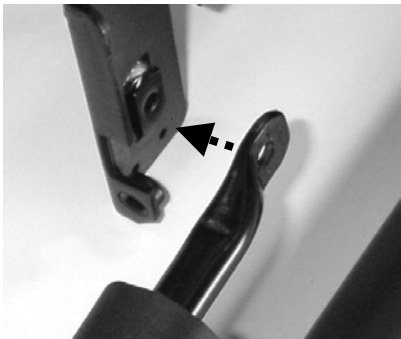

*Make sure lever is positioned with flats of lever against the bracket.*

## Seat Wheel

---

### Tools Required

5/32" hex key  
 7/16" socket and ratchet  
 Torque wrench

### CAUTION

To avoid injury, and to ensure safe operation of this product, fasteners must be tightened to the proper torque.

**1. Remove seat assembly.** See *Seat Assembly Removal* instructions.

**2. Remove wheel(s).**

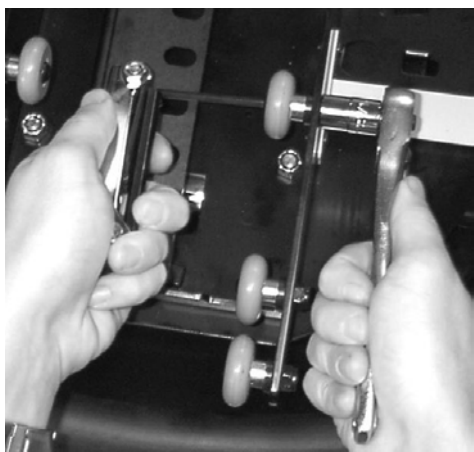

**3. Install new wheel(s) and tighten bolts to 80 in-lbs.**

*No photo.*

### Torque Setting:

80 inch-lbs

**NOTE:** For units with S/N  $\leq$  420357, discard the washer between the seat wheel and the seat channel. New seat wheels do not require the washer.

## Swivel Release Lever

### Tools Required

5/32" hex key  
 Phillips screwdriver  
 Needle nosed pliers  
 1/2" socket and ratchet  
 Long socket extension  
 7/16" socket and ratchet  
 3/8" wrench  
 Torque wrench  
 242 Loctite

### CAUTION

To ensure safe operation of this product, fasteners must be tightened to the proper torque.

**1. Remove seat assembly.** See *Seat Assembly Removal* instructions.

**2. Remove seat release bracket.**

For S/N  $\leq$  428341, see *Seat Release Bracket* instructions.

For S/N  $\geq$  428342, see *Seat Release Bracket With Stud* instructions.

**3. Swivel seat channel assembly 45° to access four bolts that attach seat channel to seat.**

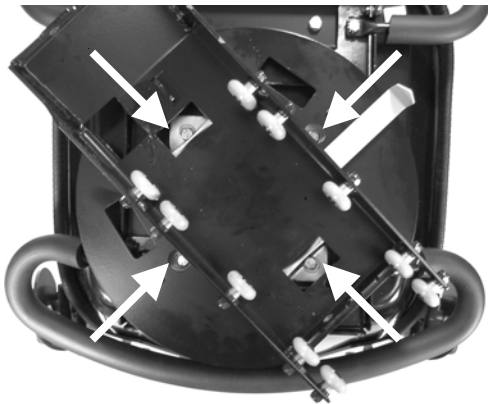

**4. Remove four bolts and washers.**

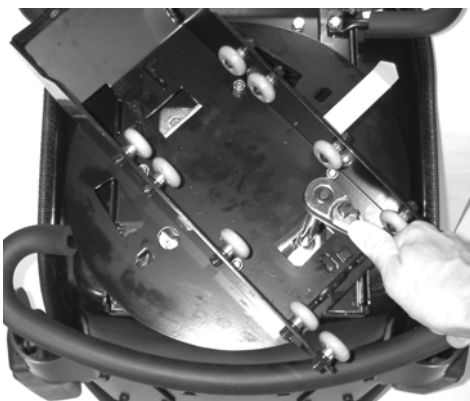

## Swivel Release Lever

---

5. Lift seat channel assembly off. Remove swivel release lever.



6. Install new swivel release lever and tighten to 80 in-lbs.



### Torque Setting:

80 inch-lbs

*Note: for S/N's 415412 - 421171, install lever using flange nuts provided with new lever. Do not install lever with washers and jam locknuts.*

7. To install seat channel, place Loctite on swivel bolts.



### CAUTION

To avoid injury and prevent adverse health effects, use Loctite in accordance with the manufacturer's material safety data sheets, including the use of safety glasses and impermeable gloves. Material safety data sheets are available via the internet at [www.loctite.com](http://www.loctite.com) or by calling Henkel Corporation at (800) 562-8483.

## Swivel Release Lever

---

**8. Swivel assembly 45° to install two bolts through cutouts.**



**9. Swivel assembly 90° to install next two bolts through cutouts.**

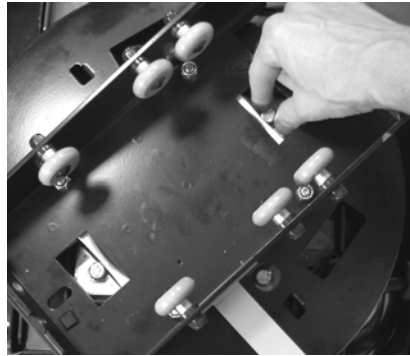

**10. Tighten all four bolts to 200 in-lbs.**

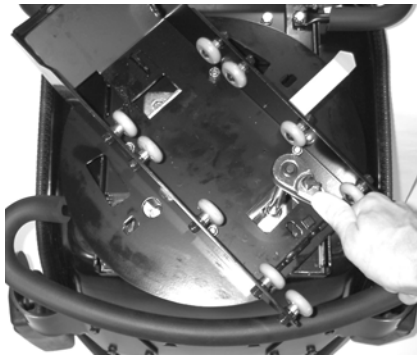

**Torque Setting:**

200 inch-lbs

**11. Check swivel and release lever operation. Swivel seat left and right and check that swivel locks in place.**



**12. Install seat release bracket.** See *Seat Release Bracket Installation* instructions.

**13. Check seat locking operation. Install seat assembly onto NuStep.** See *Seat Assembly Removal* instructions.



## Troubleshooting Guide

| PROBLEM  | POTENTIAL CAUSE  | VERIFY CAUSE  | CORRECTIVE ACTION   |
|--|--|---|---|
| <b>RESISTANCE</b>  |  |   |   |
| <b>There is no resistance.</b>                                   | Timing belt spring break.  | Lay unit on left side and inspect the spring.   | Refer to <i>Timing Belt Springs Replacement</i> instruction.                      |
|  | Poly-v belt may have come off.   | Remove covers and inspect poly-v belt.  | Refer to <i>Poly-V Belt</i> instruction.  |
| <b>Resistance feels too hard.</b>                                | Retaining rings on the Footpedal Support Tube may be causing resistance on S/N 411001-411943.  | Lay unit gently on left side and see if there are retaining rings.  | Refer to <i>Footpedal Support Tube Retaining Ring Removal</i> instruction.        |
|  | A belt may be out of alignment.  | Inspect all belts to verify they are not misaligned.  | Refer to <i>Poly-V Belt &amp; Timing Belt</i> instructions.                       |
| <b>Jerky arm movement.</b>                                       | A newer user getting used to the feel of the motion.   | Is there a slight "jerky" feeling in arms at higher Workloads?  | This is normal operation and most users will develop a smoother motion over time. |
| <b>DISPLAY &amp; ELECTRONICS</b>                                 |  |   |   |
| <b>For all problems, start with fresh batteries.</b>             | A low battery.   | Low battery indicator may be illuminated.   | Refer to <i>Battery Changing</i> instruction.                                     |
| <b>"8"s appear in all LCD display windows.</b>                   | A low battery.   | Replace batteries.  | Refer to <i>Battery Changing</i> instruction.                                     |
| <b>Not displaying WATTS, METS, CALORIES, or STEPS PER MINUTE</b> | Ribbon cable not installed correctly or cut.   | Verify cable is installed correctly and does not have any cuts.   | Refer to <i>Ribbon Cable</i> instruction.   |
|  | VR Sensor (METS, WATTS, CALORIES, TIME) and/or Hall Effect Sensor (TOTAL STEPS, STEPS PER MINUTE, TIME) gaps are off or have cut wire. | Lay unit on left side and inspect the sensor cables. VR sensor is the black & white wire, and Hall Effect sensor is red, white & black. | Refer to <i>Hall Effect</i> and <i>VR Sensor</i> instructions.                    |
|  | The sensor magnet may be missing.  | Check for the magnet on the EC disk (VR sensor-magnet) and pivot disk (Hall Effect sensor-magnet).                                      | Refer to <i>Magnet-EC &amp; Pivot Disks</i> instruction.                          |
|  | Display PC board may be bad.   | If facility has additional units, install bad display on another unit to verify that the display is bad.                                | Refer to <i>Display Removal</i> instruction.                                      |
| <b>Workload is not displaying correctly.</b>                     | Ribbon cable not installed correctly or cut.   | Inspect the cable to verify it is installed correctly and does not have any cuts.   | Refer to <i>Ribbon Cable</i> instruction.   |
|  | Contact wipers of the EC plunger plate not making contact with workload level PCB board.   | Remove cover and inspect wiper on EC plunger plate to verify it is touching the workload level PCB.                                     | Refer to <i>EC Plunger Plate</i> instruction.                                     |
|  | Workload level PCB board may be bad.   | Replace board.  | Refer to <i>Workload Lever PCB</i> instruction.                                   |
| <b>Display lights up but does not operate.</b>                   | Ribbon cable connector not plugged in correctly.   | Remove display to investigate.  | Refer to <i>Display Installation</i> instruction.                                 |
| <b>The button doesn't operate the functions</b>                  | The button may be broken.  |   | Replace the display.  |

| PROBLEM  | POTENTIAL CAUSE  | VERIFY CAUSE  | CORRECTIVE ACTION  |
|--|--|---|--|
| <b>Heart Rate not showing in the display.</b>                          | Polar receiver may be missing or defective.<br><br>Is the user wearing the Polar transmitter belt correctly?                                   | Open battery access panel and look.   | Install a Polar receiver.<br><br>Make sure chest & belt contacts are moistened, belt is well positioned.   |
| <b>The Watts aren't reading similar to the NuStep TRS3000.</b>         |  |   | This is normal. The TRS4000 is more accurate   |
| <b>SOUNDS</b>  |  |   |  |
| <b>Clicking / clanking / clunking noise linked to each step taken.</b> | Footpedal tube is compressing bumper and causing the connecting link to hit pivot disk (especially w/ left foot forward).<br><br>Seat rocking. | Take shorter steps and visually check if bumper is being hit.<br><br>Move arms without sitting on seat. If noise is not there, then patient is not set up properly.<br><br>Are front and rear shoulder bolts tight on seat release bracket? | Instruct patient to take smaller steps and move seat back one notch.<br><br>Position user one notch closer, with more weight against seat back, and adjust arms so shoulders rotate less.<br><br>Refer to <i>Seat Release Bracket</i> instruction. |
|  | Set screw loose on the rear shaft.   | Inspect bearing set screws to verify that they are tight.   | Refer to <i>Bearings – Shaft</i> instruction.  |
|  | Belt clamp hitting the workload lever tube.  | Lay unit on left side and check if belt clamp is hitting tube.  | Refer to <i>Timing Belt Spring Replacement</i> instruction.  |
| <b>Metal-to metal squeaking noise linked to each step taken.</b>       | Set screw loose on the pivot shaft.  | Inspect pivot shaft to verify the shaft is not rotating. Noise is a high-pitched squeak.  | Refer to <i>Pivot Shaft Alignment</i> instruction.   |
|  | Nut loose on the connecting link.  | Lay unit on left side to verify nuts holding the connecting link are tight at the pivot disk & arms.  | Refer to <i>Connecting Link</i> instruction.   |
|  | Nyliners for the seat release bracket are worn.  | Inspect nyliners for wear.  | Refer to <i>Seat Release Bracket</i> instruction.  |
| <b>Vibrating or groaning linked to each step taken.</b>                | Rod ends on the connecting links are bad.  | Noise ends when movement is stopped.  | Refer to <i>Connecting Link</i> instruction.   |
| <b>Metal to metal clicking noise continues after stopped stepping.</b> | Magnet misaligned.   | Is the noise a metal-to-metal sound?  | Refer to <i>EC Magnet Gap Alignment</i> instruction.   |
| <b>Other noises continue after stopped stepping.</b>                   | Poly-v belt may have become misaligned.  | Remove covers and inspect poly-v belt.  | Refer to <i>Rear Shaft Alignment</i> instruction.  |
|  | Squeaking present until disk stops moving.   | Verify belt idler arm is not rubbing on frame.  | Refer to <i>Belt Idler Arm</i> instruction.  |
|  | Front or rear shaft bearings may be bad.   | Bearing noise will be slow and consistent.  | Refer to <i>Bearing-Shaft</i> instruction.   |
|  | EC disk bearing bad.   | Spin disk rapidly and listen that noise is consistent with speed.   | Refer to <i>EC Disk &amp; Bearings</i> instruction.  |
| <b>SEAT ASSEMBLY</b>   |  |   |  |
| <b>The seat “jumps” to the next position.</b>                          | The seat lock wasn't fully engaged.  |   | Make sure the seat is fully locked in place.   |

## NuStep TRS 4000 Parts List 1.4

Note: Most parts are available individually, but to simplify installation, ASSEMBLIES (in CAPS) only come fully assembled. Items noted as *(not shown)* were replaced with current revision parts and are available as service parts, but are not shown in the Figures.

| Item               | Qty | PN#    | Part Description                     | Item               | Qty | PN#   | Part Description                   |
|--------------------|-----|--------|--------------------------------------|--------------------|-----|-------|------------------------------------|
| 1                  | 1   | 4085B  | ARM-UPPER L S/N >=412392             | 47                 | 1   | 4042A | EC MAGNET ASSY S/N >= 412485       |
| <i>(not shown)</i> |     | 4085A  | ARM-UPPER L S/N 411092-412391        | <i>(not shown)</i> |     | 4042  | EC MAG ASSY S/N 411001-412484      |
| <i>(not shown)</i> |     | 4085   | ARM-UPPER L S/N 411001-411091        | <i>(not shown)</i> |     | 40410 | EC Mag Bracket S/N 411001-412484   |
| 2                  | 1   | 4086B  | ARM-UPPER R S/N >=412392             | 49                 | 1   | 40424 | EC Magnet Slide Bracket            |
| <i>(not shown)</i> |     | 4086A  | ARM-UPPER R S/N 411092-412391        | 50                 | 1   | 4043A | EC PLUNGER PLATE ASSY S/N >=421096 |
| <i>(not shown)</i> |     | 4086   | ARM-UPPER R S/N 411001-411091        | <i>(not shown)</i> |     | 4043  | EC PLUNGER PLATE ASSY S/N <=421095 |
| 3                  | 2   | 4087   | ARM LOCK EXTRUSION                   | 51                 | 1   | 41050 | EC Shoulder Pivot                  |
| 4                  | 1   | 4081A  | ARM ASSY L S/N >= 412137             | 52                 | 1   | 40140 | Electronic Tube                    |
| <i>(not shown)</i> |     | 4081   | ARM ASSY L S/N 411001-412136         | 53                 | 1   | 41254 | FHPS 1/4"-20x7/8                   |
| 5                  | 1   | 4080A  | ARM ASSY R S/N >= 412137             | 54                 | 4   | 41052 | FHPS 1/4"-20x3/4 Black             |
| <i>(not shown)</i> |     | 4080   | ARM ASSY R S/N 411001-412136         | 55                 | 2   | 41056 | Foam Grip - Upper Arm              |
| 6                  | 1   | 40128  | Axle                                 | 56                 | 1   | 4083A | FOOTPEDAL - L S/N >=413368         |
| 7                  | 3   | 41002  | Bearing - EC Disk, Roller            | <i>(not shown)</i> |     | 4083  | FOOTPEDAL - L S/N 411001-413367    |
| 8                  | 8   | 41004  | Bearing - Pivot & Footpedal, Polymer | 57                 | 1   | 4084A | FOOTPEDAL - R S/N >=413368         |
| 9                  | 2   | 41208  | Bearing - Pivot Casting, Polymer     | <i>(not shown)</i> |     | 4084  | FOOTPEDAL - R S/N 411001-413367    |
| 10                 | 4   | 41006  | Bearing - Shafts, Roller             | 59                 | 1   | 41214 | HHCS G5 1/4"-20x1                  |
| 11                 | 9   | 41008  | Bearing - Timing Sprocket, Thrust    | 60                 | 4   | 41066 | HHCS G5 1/4"-20x3/8                |
| 12                 | 1   | 41462  | Belt - Poly-V J6 Flex >=428326       | 62                 | 2   | 41210 | HHCS G5 3/8"-16x1-3/4 Black        |
| <i>(not shown)</i> |     | 41010  | Belt - Poly-V S/N <=428325           | 63                 | 1   | 41068 | HHCS G5 3/8"-16x2-1/4              |
| 13                 | 1   | 41014  | Belt - Timing Left                   | 64                 | 1   | 41202 | HHCS G5 3/8"-16x3-3/4              |
| 14                 | 1   | 41012  | Belt - Timing Right                  | 65                 | 6   | 41234 | HHCS G5 5/16"-18x1/2 Black         |
| 15                 | 1   | 40322  | Belt Clamp - Left                    | 66                 | 4   | 41218 | HHCS G5 5/16"-18x1-3/4             |
| 16                 | 1   | 40320  | Belt Clamp - Right                   | 67                 | 8   | 41062 | HHCS G5 5/16"-18x3/4               |
| 19                 | 2   | 41016  | Belt Idler Pulley                    | 68                 | 10  | 30104 | HHCS G5 5/16"-18x5/8               |
| 20                 | 10  | 41018  | BHCS G8 1/4"-20x1-1/4                | 69                 | 1   | 41256 | Insulator board                    |
| 21                 | 1   | 40156  | Boot - Display                       | 70                 | 2   | 41200 | Knob - Arm Lock                    |
| 22                 | 1   | 40148  | Boot - Electronic Tube               | 71                 | 1   | 41080 | Knob - Load Lever                  |
| 23                 | 2   | 40210  | Boot - Pivot Casting                 | 72                 | 1   | 41076 | Label - Seat Position Indicator    |
| 24                 | 2   | 4091   | BRACKET ASSY - ANGLE COVER           | 73                 | 2   | 41180 | Label - NuStep Logo                |
| 25                 | 2   | 4093   | BRACKET ASSY - SIDE COVER            | 74                 | 2   | 41078 | Leveler Foot                       |
| 26                 | 1   | 41024  | Bumper - Footpedal Stop              | 75                 | 1   | 4044  | LOAD LEVER ASSEMBLY                |
| 27                 | 2   | 41028  | Bumper - Large                       | 76                 | 4   | 41082 | Locknut NI G5 #10-24               |
| 28                 | 4   | 41030  | Bumper - Seat Rail                   | 77                 | 1   | 41260 | Locknut NI G5 1/2"-13              |
| 29                 | 5   | 41026  | Bumper - Small                       | 78                 | 12  | 41222 | Locknut NI G5 1/4"-20 Black        |
| 31                 | 1   | 41184  | Cable - Ribbon                       | 80                 | 2   | 30157 | Locknut NI G5 3/8"-16              |
| 32                 | 2   | 41036  | Cap - Frame Crosstube                | 81                 | 2   | 41216 | Locknut NI G5 3/8"-16 Black        |
| 33                 | 2   | 41038  | Cap - Lower Arm                      | 82                 | 16  | 30106 | Locknut NI G5 5/16"-18             |
| 34                 | 1   | 40552  | Cap - Seat Rail                      | 83                 | 10  | 30109 | Lockwasher - Split 5/16"           |
| 36                 | 12  | 30267  | Clamp - Ribbon Cable                 | 84                 | 6   | 41220 | Lockwasher - Split 5/16" Black     |
| 37                 | 2   | 4074   | CONNECTING LINK ASSY                 | 85                 | 1   | 41088 | Machine Key 1/4x1/4x1-1/2"         |
| 38                 | 1   | 4090   | COVER ASSY - L                       | 86                 | 2   | 40236 | Machine Key 3/16x3/16x2-1/2"       |
| 39                 | 1   | 4092   | COVER ASSY - R                       | 88                 | 1   | 4100A | MAIN FRAME ASSY S/N>=413368        |
| 40                 | 1   | 4094   | COVER ASSY - TOP                     | <i>(not shown)</i> |     | 4100  | M FRAME ASSY S/N411001-413367      |
| 41                 | 1   | 40154A | Battery Access Panel S/N>=421388     | 89                 | 6   | 30564 | Nut - Serrated Flange G5 5/16"-18  |
| <i>(not shown)</i> |     | 40154  | Battery Access Panel S/N<=421387     | 91                 | 2   | 41096 | Nyliner 3/4"                       |
| 42                 | 1   | 40150  | Display - Bracket Assembly           | 92                 | 4   | 41092 | Nyliner 3/8"                       |
| 43                 | 1   | 4800   | DISPLAY ASSY REV 2.1                 | 93                 | 5   | 41094 | Nyliner 5/16"                      |
| 44                 | 1   | 40132  | EC Ball Detent Plate                 | 94                 | 1   | 40440 | PCBoard - Workload                 |
| 45                 | 1   | 41046  | EC Ball Plunger                      | 95                 | 2   | 30162 | PHPS T/S Typ B #8x3/8" Black       |
| 46                 | 1   | 4041A  | EC DISK ASSY S/N >= 411115           | 96                 | 2   | 41246 | PHPS Typ F #10-24x3/8 Black        |
| <i>(not shown)</i> |     | 4041   | EC DISK ASSY S/N 411001-411114       | 97                 | 7   | 41100 | PHPS w/ext washer #10-24x3/8 Blk   |

## NuStep TRS 4000 Parts List 1.4

*Note:* Most parts are available individually, but to simplify installation, ASSEMBLIES (in CAPS) only come fully assembled. Items noted as *(not shown)* were replaced with current revision parts and are available as service parts, but are not shown in the Figures.

| Item               | Qty | PN#    | Part Description                       | Item               | Qty | PN#   | Part Description                      |
|--------------------|-----|--------|--|--------------------|-----|-------|---------------------------------------|
| 99                 | 1   | 4072   | PIVOT DISK ASSEMBLY                    | 148                | 16  | 41156 | Unut #10-24                           |
| 100                | 1   | 41801  | Polar Receiver                         | 149                | 1   | 41158 | User Manual                           |
| 101                | 1   | 41407A | Poly-V Sheave S/N >=428326             | 150                | 10  | 41168 | Washer - 1/4" External Star Black     |
| <i>(not shown)</i> |     | 41407  | Poly-V Sheave S/N 424793-428325        | 151                | 1   | 41270 | Washer - M6.4x12                      |
| <i>(not shown)</i> |     | 40332  | Poly-V Sheave S/N <=424792             | 152                | 3   | 30333 | Washer - Nylon .75x1"                 |
| 102                | 8   | 41182  | Poprivet 1/8x3/16"                     | 153                | 14  | 41166 | Washer - Seat Wheel Black             |
| 103                | 2   | 30141  | Pushnut 3/8"                           | 154                | 4   | 30613 | Washer - Swivel 5/16"                 |
| 107                | 1   | 41114  | Retaining Ring - Selflocking 3/4"      | 155                | 22  | 30126 | Washer - USS 5/16"                    |
| 108                | 1   | 41258  | Retaining Ring - Takeup 1/2"           | 156                | 2   | 41170 | Wheel - Rear                          |
| 109                | 2   | 41416  | Roll Pin 1/8x1-1/8"                    | 157                | 10  | 41502 | Wheel - Seat                          |
| 110                | 1   | 30120  | Seat                                   | 158                | 2   | 41318 | Pivot Cam                             |
| 111                | 2   | 30624  | Seat Armrest                           | 159                | 6   | 41326 | BHCS G8 1/4-20x3/4"                   |
| 112                | 1   | 30628  | Seat Armrest Bracket - Left            | 160                | 2   | 41324 | Cap - Arm Pivot Cam                   |
| 113                | 1   | 30626  | Seat Armrest Bracket - Right           | 161                | 2   | 4102  | FP STABILIZER S/N>=413368             |
| 114                | 4   | 30625  | Seat Armrest Spacer                    | <i>(not shown)</i> |     | 40220 | FP Support Tube S/N 411001-413367     |
| 115                | 1   | 4050   | SEAT ASSEMBLY                          | <i>(not shown)</i> |     | 41110 | Ret Ring -Ext 1" S/N 411001-413367    |
| 116                | 1   | 40510  | Seat Channel Weldment                  | 162                | 2   | 41432 | Shoulder Bolt 3/8x7/8"                |
| 117                | 1   | 40500  | Seat Mounting Bracket                  | 163                | 2   | 41328 | Shoulder Bolt 3/8x1/2"                |
| 118                | 1   | 40524  | Seat Position Indicator                | 164                | 4   | 41338 | PHPSw/ext washer #10-24x5/16" Blk     |
| 119                | 1   | 40550  | Seat Rail                              | 165                | 2   | 41116 | Retaining Ring - Takeup 1"            |
| 120                | 1   | 4051   | SEAT RELEASE BRACKET ASSY              | 166                | 3   | 41340 | Shoulder Bolt 5/16x3/8"               |
| 121                | 1   | 4053   | SEAT RELEASE LEVER ASSY                | 167                | 2   | 41342 | Wave Washer 5/16x5/8"                 |
| 122                | 1   | 4055   | SEAT RELEASE LEVER BRKT ASSY           | 168                | 2   | 41336 | Footpedal Bearing Spacer              |
| 123                | 1   | 40560  | Seat Stop Pin Weldment                 | 169                | 1   | 41805 | AC Adapter & Cable - US & Canada 110V |
| 124                | 1   | 4064A  | SENSOR - HALL EFFECT ASSY S/N >=422081 | <i>(not shown)</i> |     | 4150  | AC Adapter & Cable - Europe 220V      |
| <i>(not shown)</i> |     | 4064   | SENSOR - HALL EFFECT ASSY S/N <=422080 | 170                | 16  | 30119 | Washer - SAE 3/8"                     |
| 125                | 1   | 4062A  | SENSOR - VR ASSEMBLY S/N >=422081      | 171                | 2   | 41027 | Bumper - Footpedal II Male            |
| <i>(not shown)</i> |     | 4062   | SENSOR - VR ASSEMBLY S/N <=422080      | 174                | 4   | 41433 | 1/4 - 20 Prevailing Torque Flange Nut |
| 126                | 4   | 41122  | Set Screw 5/16"-18x1/2                 | 175                | 2   | 41246 | 10-24x3/8 PHPS Type F Blkzinc         |
| 127                | 8   | na     | Set Screw 1/4"-28x1/4                  | 177                | 1   | 41464 | Spacer - Pivot Disk Belt              |
| 128                | 4   | na     | Set Screw 5/16"-24x1/4                 | 178                | 1   | 4300  | Water Bottle Holder                   |
| 129                | 1   | 40600  | Shaft - Pivot Arm                      | 179                | 1   | 4305  | Reading Rack                          |
| 130                | 1   | 40604  | Shaft - Rear                           | 180                | 1   | 4310  | 123GO! Instruction Panel              |
| 131                | 2   | 41230  | Shoulder Bolt 3/8x1"                   | 181                | 1   | 4315  | Display Accessory Kit                 |
| 132                | 2   | 41232  | Shoulder Bolt 3/8x1-3/4"               | 182                | 2   | 41414 | Washer - Shim .375x.563x.030          |
| 133                | 2   | 41134  | Shoulder Bolt 3/8x2-1/2"               | 183                | 1   | 40156 | Boot - Display                        |
| 134                | 2   | 41136  | Shoulder Bolt 5/16x1/4"                | 184                | 1   | 41467 | 3/8x3/4x.090 Thrust Washer            |
| 135                | 1   | 41140  | Spring - Front Seat Lever              | 185                | 1   | 41469 | 5/16x3/8x1/4 Flange Bearing           |
| 136                | 1   | 41138  | Spring - Belt Idler                    | 186                | 1   | 41470 | 5/16-18 Locknut, Black Zinc           |
| 137                | 2   | 41142  | Spring - Rear Seat Lever               | 187                | 2   | 40368 | 10-32x5/16 HXMS-Zinc                  |
| 138                | 1   | 41144  | Spring - Seat Release Bracket          | 188                | 1   | 40362 | Timing Belt Clamp-Top R               |
| 140                | 1   | 4099   | SUPPORT ASSY - STEP THROUGH            | 189                | 1   | 40374 | Belt-Flat                             |
| 141                | 1   | 41148  | Swivel                                 | 190                | 2   | 40364 | Timing Belt Clamp-Bottom Assy         |
| 142                | 1   | 4056   | SWIVEL REL LEVER BRKT ASSY             | 191                | 1   | 40370 | Bracket-Flat Belt Pulley Assy         |
| 143                | 1   | 4054   | SWIVEL RELEASE LEVER ASSY              | 192                | 1   | 40376 | Pulley-Flat Belt Idler 3.38           |
| 144                | 9   | 41152  | THPS #10-24x1/2" Black                 | 193                | 1   | 30153 | 3/8-16x1-3/4 HHCS G5 Zinc             |
| 145                | 16  | 41154  | THPS #10-24x3/4" Black                 | 194                | 1   | 40366 | Flat Belt Clamp-L                     |
| 146                | 8   | 41252  | THPS #6-32x1/4                         | 195                | 1   | 40363 | Timing Belt Clamp-Top L               |
| 147                | 2   | 4070   | TIMING BELT SPROCKET ASSY              |                    |     |       |                                       |

FIGURE 1.4

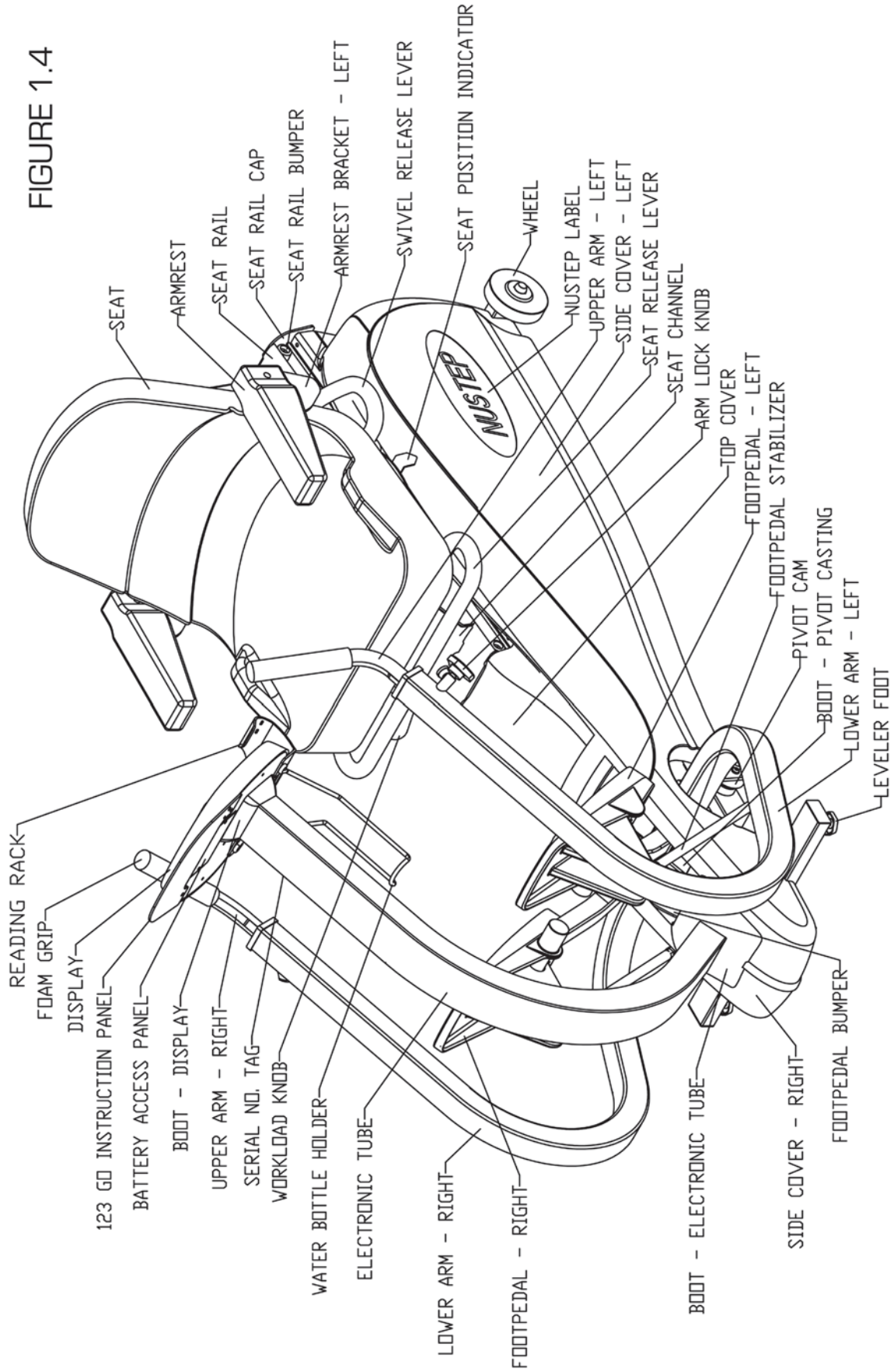

⌘

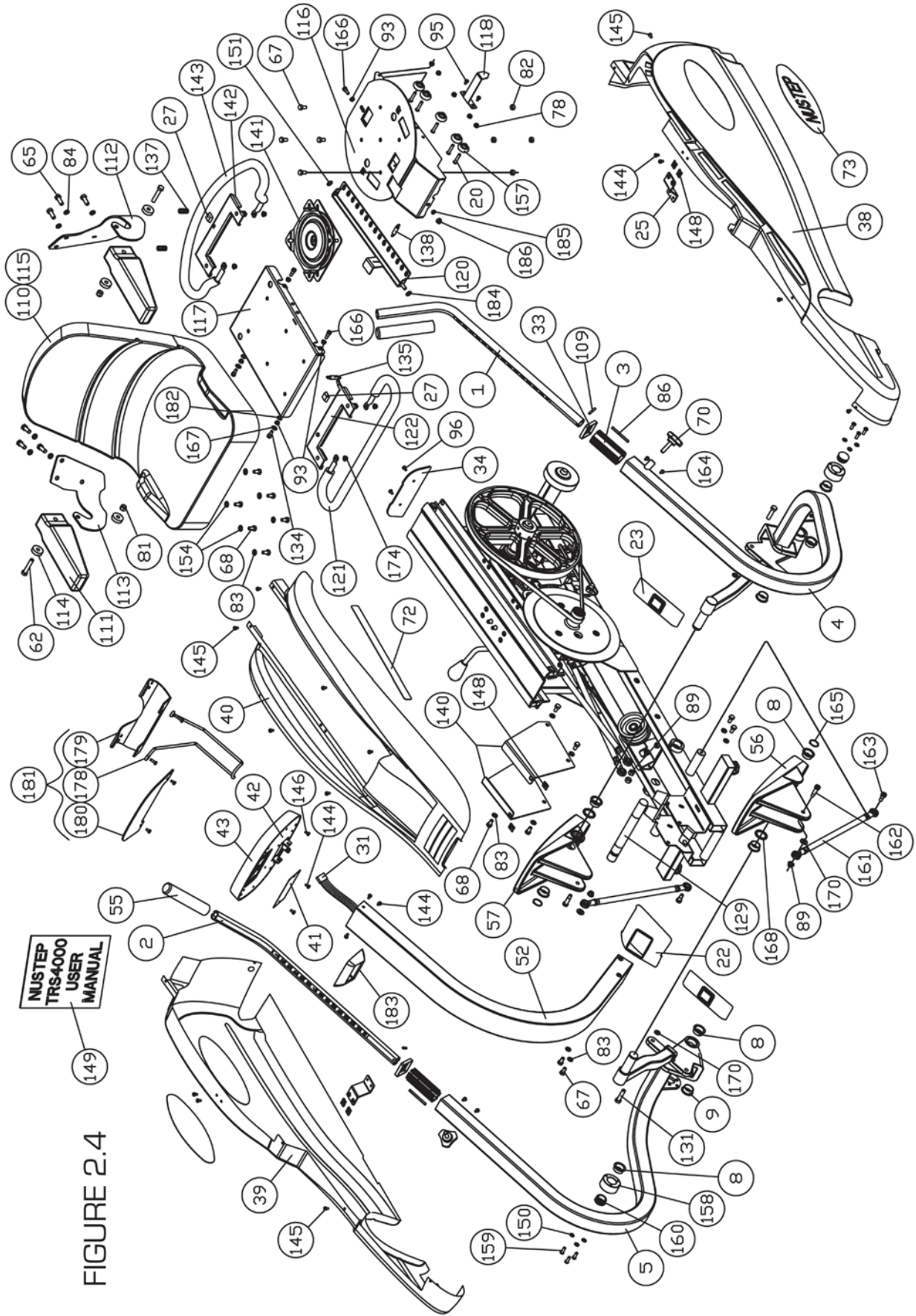
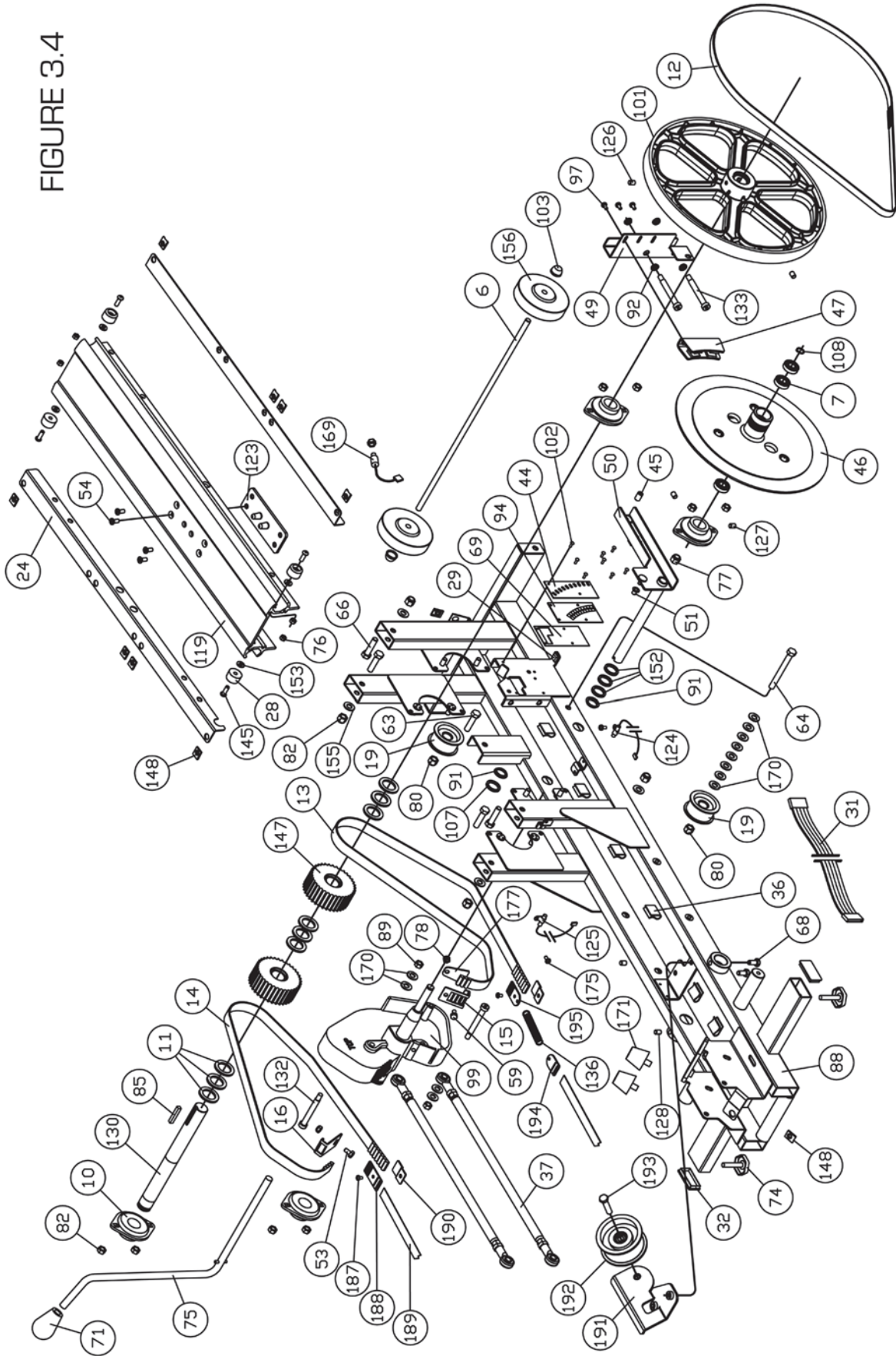

FIGURE 2.4

FIGURE 3.4









**NuStep, Inc.**  
**5111 Venture Drive, Suite 1**  
**Ann Arbor, MI 48108**  
**(800) 322-2209**  
**www.nustep.com**

NuStep® is a registered trademark of NuStep, Inc.

US Patent Nos. 5,356,356, 6,042,518, 6,361,479, 6,666,799

Design Patent Nos, D359,777, D421,075 and other patents pending.

Made in USA

Copyright May 2005 by NuStep, Inc. PN 41904B

All rights reserved.



**We Transform Lives.**

The information in this manual is the most current at the time of printing. Due to our commitment toward continuous improvement, specifications and descriptions are subject to change without notice. No part of this manual may be reproduced or transmitted in any form or by any means, electronic or mechanical, for any purpose without the express written permission of NuStep, Inc.