

Manual 828 E



Contents

Monark Exercise AB	4
Product Information	5
<i>Serial number.....</i>	5
Operating Instruction.....	6
<i>Workload device</i>	6
<i>Power measurement.....</i>	6
<i>Cycle adjustments.....</i>	6
<i>Computer specifications.....</i>	7
<i>Computer Instruction.....</i>	7
<i>Scale - zero adjustment</i>	8
<i>Calibration</i>	8
Troubleshooting	9
Service.....	10
<i>Warning.....</i>	10
<i>Warranty</i>	10
<i>Service check & maintenance.....</i>	10
<i>Batteries.....</i>	11
<i>Crank bearing</i>	11
<i>Flywheel bearing.....</i>	11
<i>Transport.....</i>	11
<i>Replacement of brake belt.....</i>	11
<i>Brake belt contact surface</i>	11
<i>Chain 1/2" x 1/8"</i>	12
<i>Freewheel sprocket.....</i>	13
Spare parts.....	14

Important

Read the manual carefully before using the cycle and save it for future use.

Monark Exercise AB

Monark has 100 years' experience of bicycle production. The Monark tradition has yielded know-how, experience, and a real feel for the product and quality. Since the early 1900s, Monark's cycles have been living proof of precision, reliability, strength and service. That are the reasons why we are now the world leader in cycle ergometers and the market leader in Scandinavia in transport cycles.

We manufacture, develop and market ergometers and exercise bikes, transport bikes and specialized bicycles. Our largest customer groups are within health care, sports medicine, public authorities, industry and postal services.

For more information: www.monarkexercise.se



Product Information

Congratulations on your new Ergometer

The Monark 828 E is the world's most commonly used exercise ergometer. The adjustable brake system and the force can be set and read Kiloponds (kp) and Newton (N). The actual brake power is showed in Watts on the electronic meter.

The cycle is equipped with an electronic meter showing pedal revolutions per minute (RPM), heart rate in bpm (HR), exercise time in minutes and seconds (TIME), speed in km per hour or miles per hour (SPEED), covered distance in km or mile (DISTANCE), burned Calories (CAL) and the power on the cycle (WATT). The watt level depends on pedalling speed, it can be fine tuned by increasing or decreasing the speed or pedal rpm.

Each 828 E is calibrated at the factory. This means that you can begin to use the Ergometer directly after assembly. However, if the user wishes to verify the scale, please read the instruction for "Calibration" in this manual.

NOTE!

Use of the product may involve considerable physical stress. It is therefore recommended people who are not accustomed to cardio or not feel completely healthy to first consult a physician for advice.

Facts

- Large, well-balanced flywheel 20 kg (44 lbs)
- Pendulum scale, easy to calibrate
- Adjustable seat height
- Adjustable handlebar with quick release lever
- Stable frame, solid steel tube
- Powder painted
- Wheels for easy transport
- Electronic display with heart rate

Width

517 mm (20,3") at handlebar
640 mm (25") at support tubes

Length

1120 mm (44")

Height

945-1295 mm (37,2-51") at handlebar
780-1105 mm (30,7-43,6") at seat

Weight

52 kg (114,5 lbs)
Max user weight 250 kg (551 lbs)

Included

Chestbelt
PC software

Serial number

The serial number of your Ergometer is placed according to *fig: Serial number*.

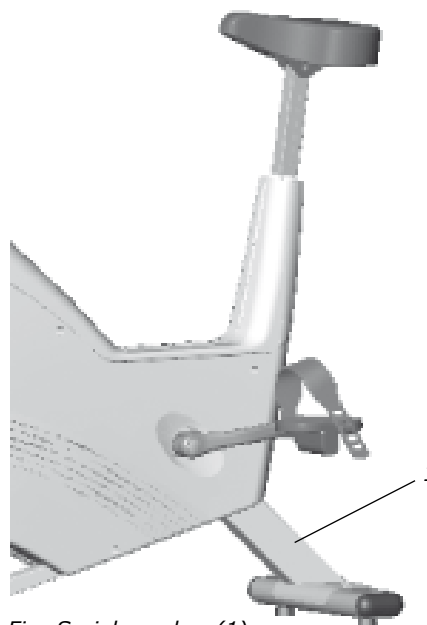

Fig: Serial number (1)

Operating Instruction

Workload device

The 828 E uses a brake belt system to control the resistance. A change of the workload is done either by changing the pedalling speed or by turning the workload adjusting knob(1) or. See *fig: Workload device*.

Power measurement

The cycle is designed to measure the power on the flywheel, because tests/protocols are made for it (for example Åstand's and YMCA).

Cycle adjustments

Seat height should be adjusted to a comfortable position. The appropriate height can be to have the knee slightly bent when the sole of the foot is centred over the pedal axle with the pedal to the bottom position. To adjust the seat height loosen the lever on the seat tube(1). See *fig: Adjustments*.

The handlebar setting shall give a comfortable position when cycling. During longer exercise sessions it is recommended to occasionally change the handlebar position. To adjust the handlebar loosen the quick release lever(2). See *fig: Adjustments*.

NOTE! The handlebar stem should be inserted into the frame tube at least 3 inches (about 8 cm). This measure is marked with "MAX" on the stem(3).

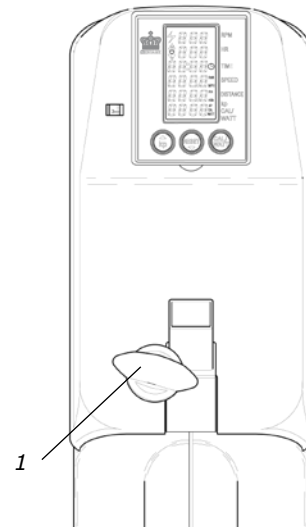

Fig: Workload device (1)

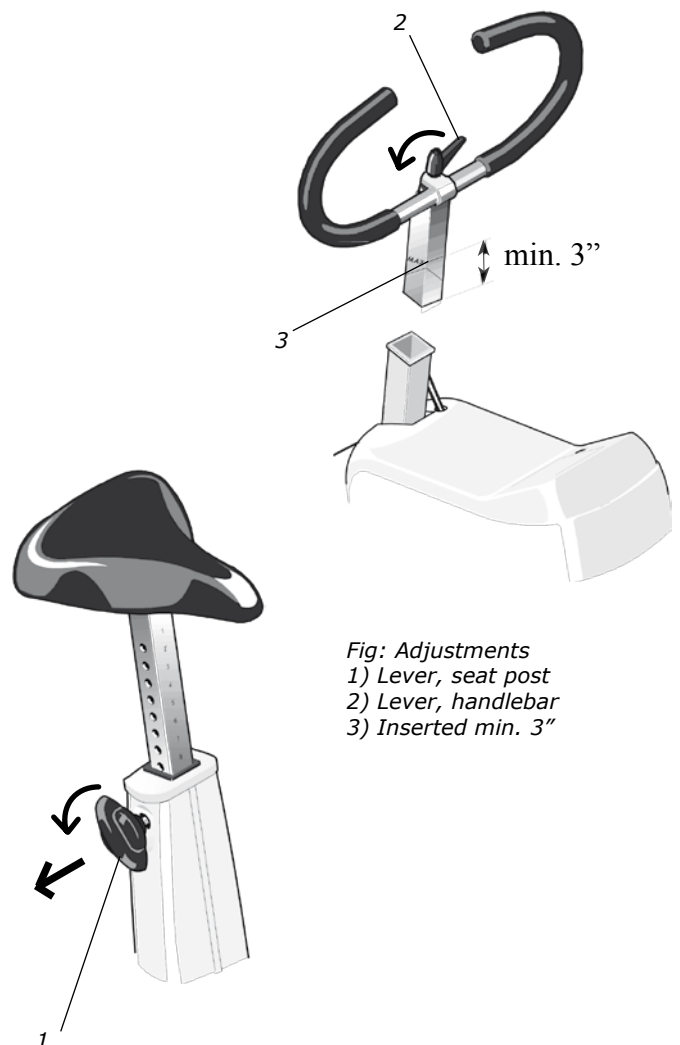
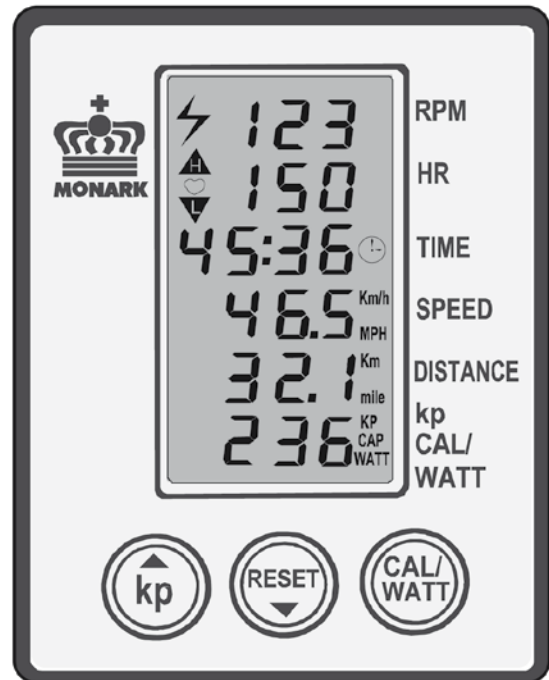
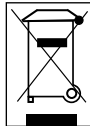

Fig: Adjustments
1) Lever, seat post
2) Lever, handlebar
3) Inserted min. 3"

Computer specifications

Display		
RPM	0 - 250	rev./min
HR	50 - 240	bpm
TIME	0:00-99:59	min:sec
SPEED	0 - 99	km/h or mph
DISTANCE	0.0 - 99.9	km or mile
FORCE	0.0 - 7.0	kp
CALORIES	0 - 999	kcal
WATT	0 - 7 x rpm	watt

Batteries: 1.5 V x 2, R6 (AA)
 Storing temperature: -10°C - +60°C
 Operating temperature: 0°C - 50°C



Computer Instruction

Press any button or move the pedal to turn on the meter. At the display for heart rate (HR) a heart symbol is lit which means that the meter is trying to find a pulse signal from an external source (chestbelt with electrodes, Art. No: 9339-98). If the meter can not find the heart rate signal the HR-function is automatically turned off after 30 seconds. When the function is turned off the heart symbol is not lit any more. The heart rate function can be turned on again by pressing a key.

The timer starts automatically when the pedals are moved. Meter values for Time, Distance and Calories can be set to zero by pressing the RESET-key for more than two seconds. To get correct readings for calories and watts, the kp-value on the electronic meter has to be set to the same value as the pendulum, or the kp-window shown to the left of the electronic meter.

Example: The pendulum and the kp-window is showing 2 kp. Press the kp-key to the left on the meter. The lower display window is now showing figures in kp. Increase or decrease in steps of 0.1 kp by pressing the kp-key - (arrow up) or the RESET-key - (arrow down) until the reading corresponds with the actual or desired kp-values on the pendulum scale or in the kp-window. After that press the CAL/WATT-button to either show the CAL- or WATT-figures. The watt reading in the display is depending on the pedalling speed. The watt reading can then be fine tuned through increase or decrease of the pedalling speed. Calories are calculated all the time.

Do not expose the electronic meter to direct sunlight or extremely high temperature. Do not use any dis-solvent when cleaning. Use only dry cloth.

Scale - zero adjustment

Loosen tension device so that the brake belt feels loose. Check that the pendulum will hang in vertical position.

Scale board:

Check that the index on the pendulum(2) weigh is aligned with the index at the 0-position on the scale board. If adjustment is necessary, first loosen the locknut(1) and then change the position of the board. Tighten the lock-nut after the adjustment. See *fig: Scale adjustments*.

Kp-scale:

At the same time, check that the kilopond-scale(5) to the left of the meter, shows 0 in line with the index. To adjust the kp-scale loosen the lock screw for scale indicator(9). Tighten the screw firmly after the adjustment. See *fig: Calibration, Adjustment kp-scale window*.

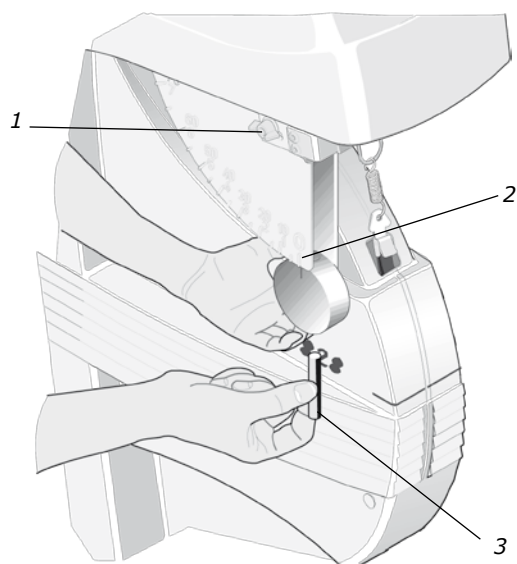

Fig: Scale adjustment

- 1) Locking nut
- 2) 0-index
- 3) Adjustment weight, pendulum

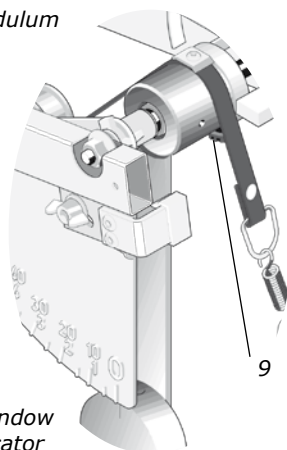

Fig: Adjustment kp-scale window
9) Lock screw for scale indicator

Calibration

Although all Ergometers are calibrated at the factory the user may wish to verify this by performing a mechanical scale calibration. If so please do the following.

Remove the brake belt from the spring. Lean the bike forward so that the calibration weight, 4kg(4) (Art. No: 9000-211) is hanging independently from the frame cover. Be sure that the scale board is set to zero before the weight is put on, see section "Scale - zero adjustment". Put the weight on on the spring(6). When correctly set, it should be possible to read this weight from the corresponding place on the scale board(7). See *fig: Calibration*.

Should there be a deviation, adjust the pendulum to the correct weight on the scale by means of the adjusting weight inside the pendulum(3). See *fig: Scale adjustment*. To change the position of the adjusting weight, loosen the lock screw(8) on the back of the pendulum weight. Should the index of the pendulum weight be too low, move the adjusting weight upwards in the weight and if the index should be too high the adjusting weight is moved somewhat downwards and locked in the new position. Repeat until the correct reading is achieved.

Check the calibration of the pendulum weight once a year or when needed.

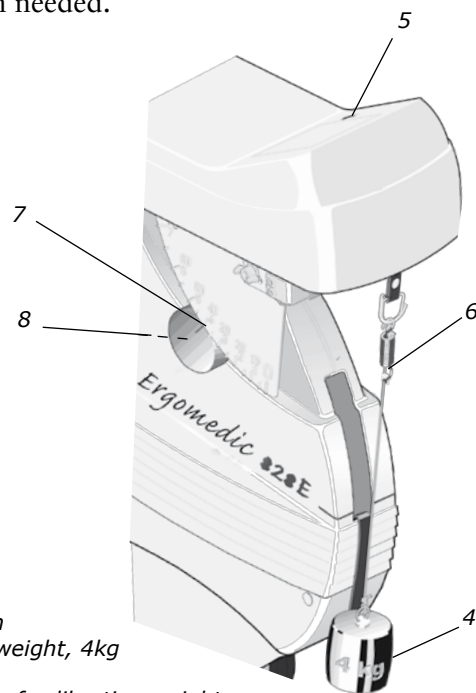

Fig: Calibration

- 4) Calibration weight, 4kg
- 5) kp-scale
- 6) Attachment of calibration weight
- 7) Pendulum at 4kp
- 8) Screw to adjustment weight

Troubleshooting

Symptoms	Probably cause/measure
There is a click noise with every pedalling (increases with the weight).	The pedals are not tightly drawn, tighten them or change pedals. There is a loose in the crank cheek, tighten. There is a loose in the base bearing, contact your dealer for service
Scratching sound is heard when pedalling.	Check that the carriage block is taken off and that none of the covers is scratching.
There is a click noise and a squeak noise when pedalling.	Untighten the chain a bit.

Service

Warning

Make sure the voltage indicated on the appliance corresponds to the local mains voltage before making connections.

Warranty

EU countries - Private use

If you are a natural person you will have a minimum level of protection against defects in accordance with EC Directive 1999/44/EC. In short, the directive provides for that your Monark Dealer will be liable for any defects, which existed at the time of delivery. In case of defects, you will be entitled to have the defect remedied within a reasonable time, free of charge, by repair or replacement.

EU countries - Professional use

Monark Exercise products and parts are guaranteed against defects in materials and workmanship for a period of one year from the initial date of purchase of the unit. In the event of a defect in material or workmanship during that period above, Monark Exercise will repair or replace (at its option) the product. Monark Exercise will do so at its expense for the cost of materials but not for labour or shipping.

Other countries

Monark Exercise products and parts are guaranteed against defects in materials and workmanship for a period of one year from the initial date of purchase of the unit. In the event of a defect in material or workmanship during that period above, Monark Exercise will repair or replace (at its option) the product. Monark Exercise will do so at its expense for the cost of materials but not for labour or shipping.

Service check & maintenance

To keep your Ergometer in good shape you should make a regular service.

Service action:

- If you wish to disinfect the surface of the bike we recommend isopropyl alcohol. Use a damp but not wet cloth to clean the surface you wish to disinfect.
- Keep your Ergometer clean and properly lubricated (once a week).
- Periodically wipe the surface with a rust preventative, especially when it has been cleaned and the surface is dry. This is done to protect the chrome- and zinc parts as well as the painted parts (4 times per year).
- Check now and then that both pedals are firmly tightened. If not the threading in the pedal arms will be damaged. Also check that pedal arms are firmly tightened on the crank axle, tighten if necessary. When the Ergometer is new it is important to tighten the pedals after 5 hours of pedalling (4 times per year).
- Check that the pedal crank is secure to the crank axle (4 times per year).
- Be sure that the pedals are moving smoothly, and that pedal axle is clear of dirt and fibres (4 times per year).
- When cleaning and lubricating be sure to check that all screws and nuts are properly tightened (2 times per year).
- Check that the chain is snug and there is no play in the pedal crank (2 times per year).
- Check that pedals, chain and freewheel sprocket are lubricated (2 times per year).
- Be sure that the brake belt does not show significant signs of wear (2 times per year).
- Check that the handlebars and seat adjustment screws are lubricated (2 times per year).
- Be sure that all moving parts as crank and flywheel are working normal and that no abnormal play or sound exists. I.e. play in bearings causes fast wearing and with that follows a highly reduced lifetime.
- Check that the flywheel is placed in the center and with plane rotation.

Batteries

If the meter is battery-operated, the batteries are in a separate package at delivery. If the storing time has been long the battery power can be too low to make the computer act correctly. Batteries must be changed.

Crank bearing

The crank bearing is long term greased and require normally no supplementary lubrication. If problem arises, please contact your Monark dealer.

Flywheel bearing

The bearings in the flywheel are lifetime greased and require normally no maintenance. If problem arises, please contact your Monark dealer.

Transport

At transport the brake belt should be somewhat tightened to prevent it from falling off the flywheel.

Replacement of brake belt

To replace the brake belt remove covers if necessary. Make sure that the belt is loose.

Alt. 1: To loosen the belt on pendulum bikes with motor, turn the power on and move the pendulum to 4 kp. Hold it there until brake belt is loose. Observe how the belt is connected. Take it apart and remove it from the bike. Attach the new brake belt and assemble the bike in reverse order.

Alt. 2: To loosen the brake cord on cycles with weight basket set the basket to its upper position. Loosen the lock washer that is holding the cord and remove it from the tension center. Loosen or cut of the knot in the other end of the cord and then remove the hole cord from the bike. When assembling a new brake cord, first enter one end into the hole in the tension center, and tie a knot and let the knot fall into the bigger part of the hole. Lock the end of the cord with the lock washer.

Alt. 3: To loosen the belt on other bikes remove all possible tension. Observe how the belt is connected. Take it apart and remove it from the bike. Attach the new brake belt and assemble the bike in reverse order.

NOTE: When replacing the brake belt it is recommended to clean the brake surface. See "Brake belt contact surface".

Brake belt contact surface

Deposits of dirt on the brake belt and on the contact surface may cause the unit to operate unevenly and will also wear down the brake belt. The brake belt contact of the flywheel surface should then be ground off with fine sandpaper and any dust removed with a clean dry cloth.

Remove if there are any covers and loosen the tension on the brake belt. Grind with a fine sandpaper. Grinding is easier to perform if a second individual cautiously and carefully pedals the cycle.

Irregularities on the brake belt contact surface are removed by means of a fine sandpaper or an abrasive cloth. Otherwise unnecessary wear on the brake belt may occur and the unit can become noisy.

Always keep the brake belt contact surface clean and dry. No lubricant should be used. We recommend replacing the brake belt when cleaning the contact surface. In regard to assembly and adjustment of the brake belt, see "Replacement of brake belt".

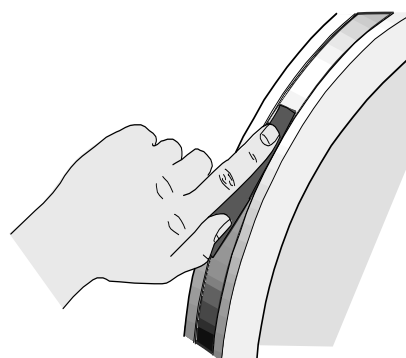

Chain 1/2" x 1/8"

It is strongly recommended to keep the chain clean. Dirt build-up on the chain will cause excess wear. A chain lubricant and solvent for normal road bikes may be used.

Check the lubrication and tension of the chain in regular intervals. In the middle of its free length the chain should have a minimum play(3) of 10 mm (1/4 inch). See *fig: Chain adjustments*. When the play in the chain is about 20 mm (3/4 inch) it must be tightened otherwise it will cause abnormal wear of the chain and chainwheels. Because of this it is always recommended to keep the chain play as little as possible. Loosen the hub nut(2) on both sides and tense the chain with the chain adjuster(1) when needed.

When the chain has become so long that it can no longer be tightened with the chain adjusters it is worn out and shall be replaced with a new one.

To adjust or replace the chain remove frame covers if necessary.

To adjust the chain the hub nuts(2) should be loosened. Loosening or tightening the nuts on the chain adjusters(1) will then move the hub and axle forward or backward. Adjust according to above recommendation. Then tighten the nuts on the hub axle again. See *fig: Chain adjustments*.

To replace the chain loosen the chain adjuster as much as possible. Dismantle the chain lock(6) and remove the chain. Put on a new chain and assemble the chain lock. The spring of the chain lock should be assembled with the closed end in the movement direction(5) of the chain. Use a pair of tongs for dismantling and assembling the spring(4). See *fig: Chain replacement*.

NOTE: At assembly the flywheel has to be parallel with the centerline of the frame otherwise the chain and chain wheels makes a lot of noise and wears out rapidly.

Adjust chain adjusters to allow chain play according to above. Tighten hub nuts firmly. Put on frame covers again.

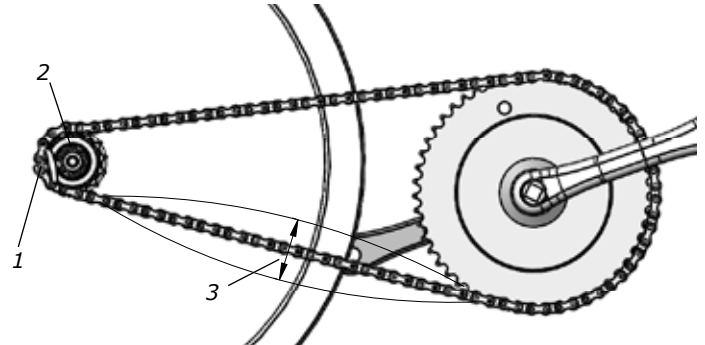

Fig: Chain adjustments
1) Chain adjuster
2) Hub nut
3) Chain play

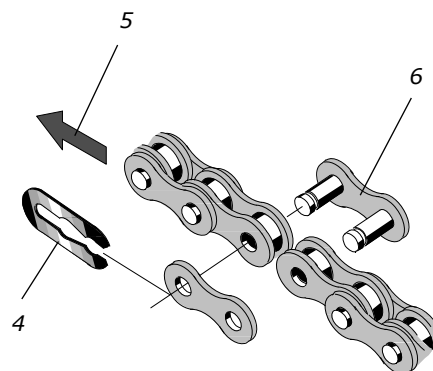

Fig: Chain replacement
4) Lock spring
5) Movement direction
6) Chain lock

Freewheel sprocket

When replacing the freewheel sprocket remove frame covers if necessary. Dismantle the chain as described in part "Chain 1/2" x 1/8" ".

Loosen the axle nuts and lift off the flywheel. Remove the axle nut, washer, chain adjuster and spacer on the freewheel side. Place the special remover (Art. No. 9100-14) in the adapter and place the spacer and axle nut outside. See *fig: Special remover*. Replace sprocket-adapter and assemble the new parts in reverse order according to the above.

NOTE: Do not tighten the axle nut completely. It must be possible to loosen the adapter-sprocket half a turn.

The sprocket should be lubricated with a few drops of oil once a year. Tilt the cycle somewhat to make it easier for the oil to reach the ball bearing. See *fig: Lubrication*.



Fig: Lubrication



*Fig: Special remover
(Art. No: 9100-14)*

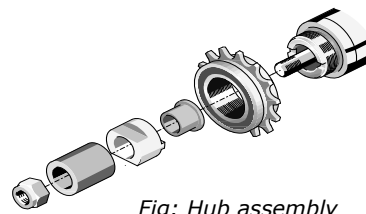
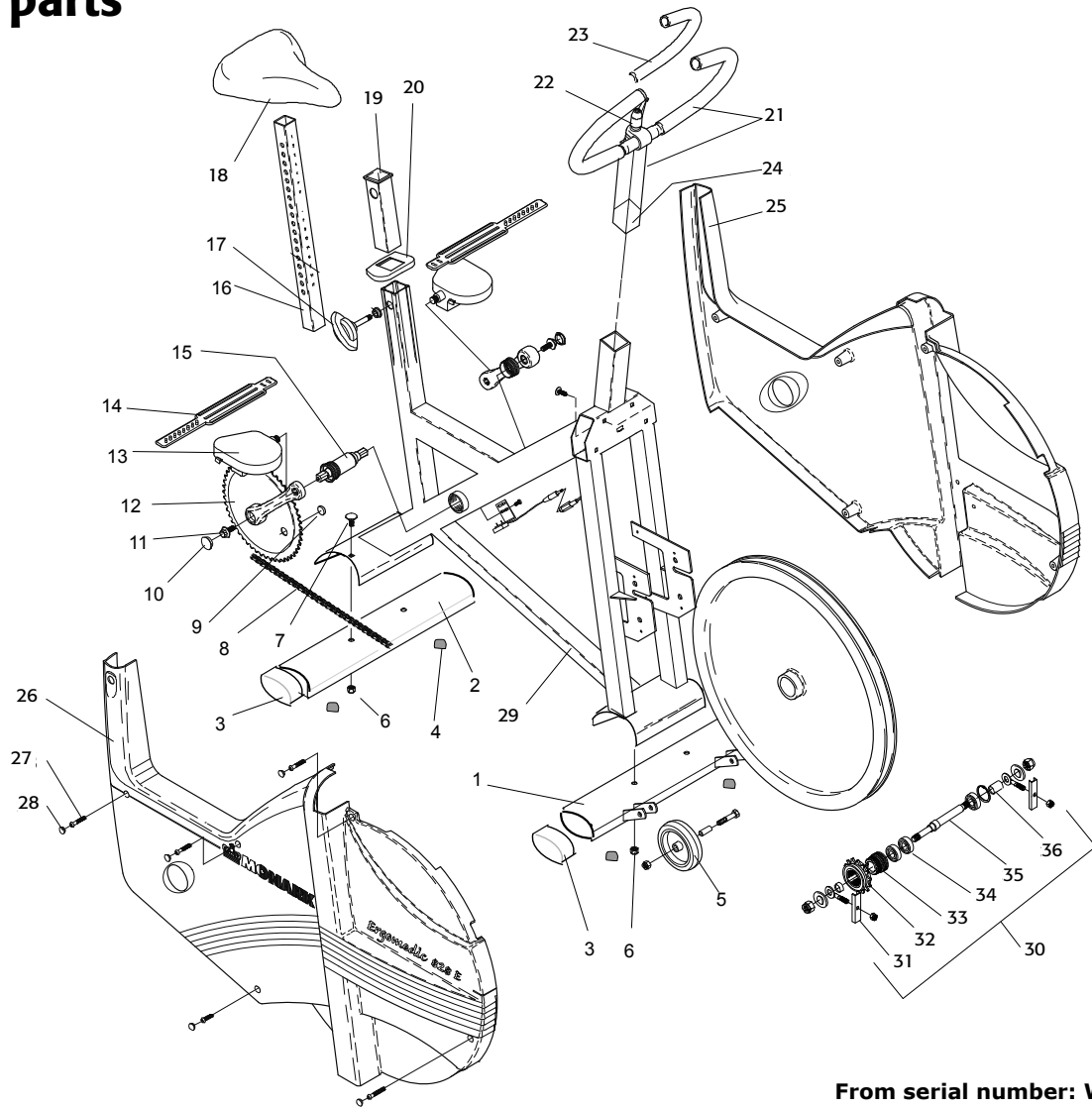

Fig: Hub assembly

Spare parts



From serial number: WBK 265820C

Pos.	Qty.	Art. No.	Description	Pos.	Qty.	Art. No.	Description
1	1	9301-15	Support tube, front	19	1	9300-115	Bushing for saddle post
2	1	9301-16	Support tube, rear	20	1	9300-123	Top cover
3	4	9328-51	Plastic cap, blue	21	1	9300-280	Handlebar complete
4	4	9328-26	Rubber foot	22	1	9100-180	-Lever M8
5	1	9328-37	Transport wheel compl. (pair)	23	1	9126-72	-Handgrip (pair)
6	4	5845	Locking nut M8	24	1	9300-291	-Expander wedge
7	2	9300-12	Screw MVBF M8x16 mm	25	1	9300-61	Frame cover, left
8	1	9300-55	Chain 1/2" x 1/8", 116 l	26	1	9300-60	Frame cover, right
9	1	9326-164	Magnet	27	4	5673-9	Mounting screw LKT-TT 5x12mm
10	2	8523-2	Dust cover	28	10	9306-12	Plastic plug
11	2	8523-115	Screw M6S 8.8 M8 x 20 FZB	29	1	9301-5	Frame
12	1	9300-430	Steel crank set, complete	30	1	9300-24	Wheel suspension, complete set
13	1	9300-220	Pedal, pair	31	1	9000-12	-Chain adjuster (pair)
14	1	9300-207	Pedal strap, pair	32	1	9106-13	-Sprocket
15	1	8966-175	BB cartridge bearing, complete	33	1	9106-14	-Connection
16	1	9300-138	Saddle post	34	3	91001-6	-Bearing 6001-2z
17	1	9300-133	Locking screw, complete	35	1	9300-18	-Axle
	1	9300-122	-Locking knob	36	1	9300-17	-Bush, 23 mm
	1	9300-134	-Pressure washer		1	9339-98	Chestbelt
18	1	4994-5	Saddle		1	9300-365	PC program
	1	9300-114	-Saddle bracket				

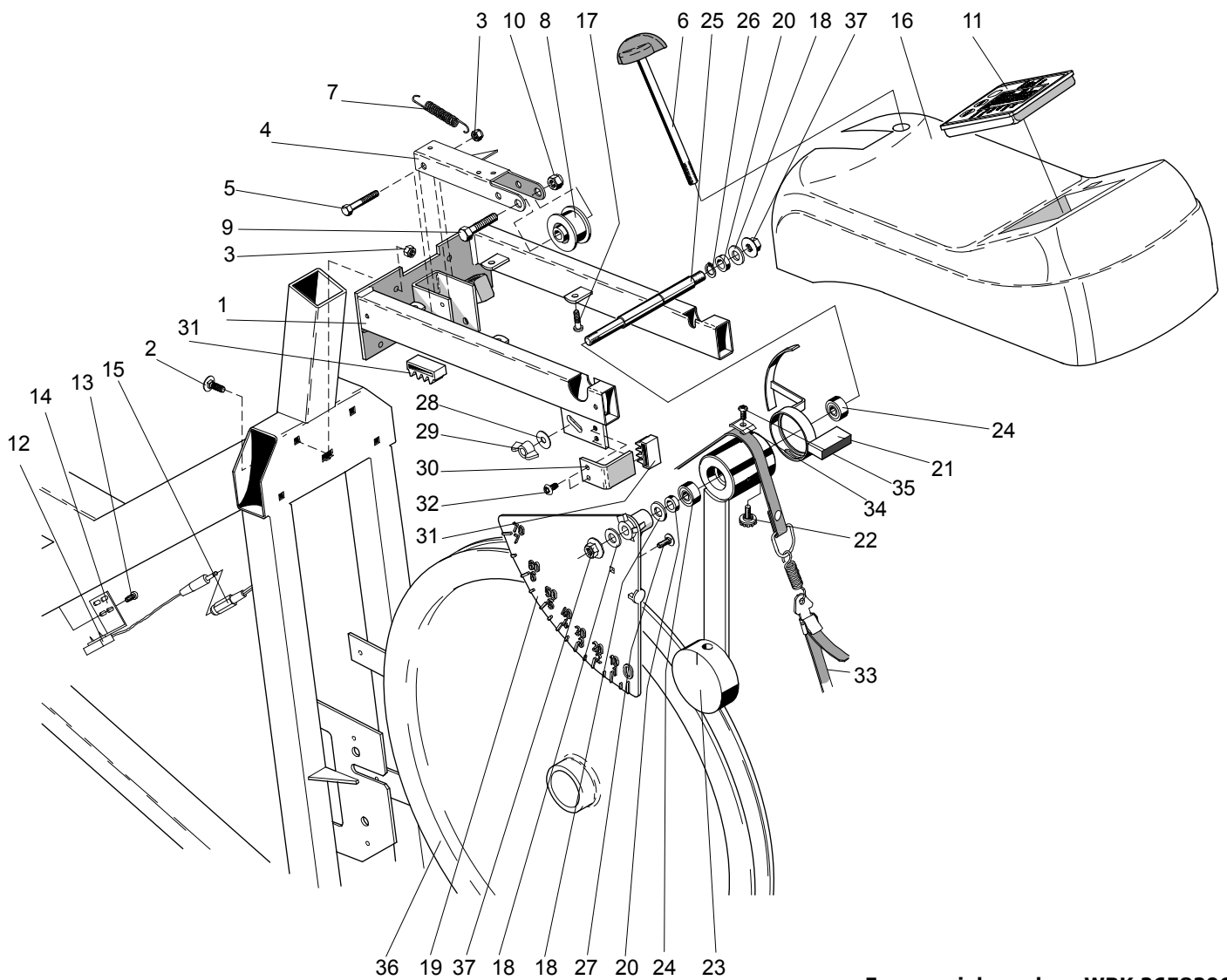

From serial number: WBK 265820C

Pos.	Qty.	Art. No.	Description	Pos.	Qty.	Art. No.	Description
1	1	9300-30	Frame for equipment	18	3	5866	Washer
2	4	9300-21	Screw MVBF 6x16 mm		1	9300-36	Meter panel, complete
	4	5863	Washer	19	1	9339-100	-Meter panel
3	5	5843-9	Nut M6	20	2	9000-17	-Spacer
4	1	9300-22	Tension lever	21	1	9300-93	-Meter reader 7kp
5	1	14333-9	Screw M6x45 mm	22	1	9000-103	-Screw
6	1	9300-25	Tension screw M8, complete	23	1	9300-88	-Weight lever
7	1	9100-20	Spring	24	2	19001-6	-Bearing 6001-2z
8	1	9100-26	Tension cylinder complete	25	1	9300-86	-Axle
9	1	14358	Screw M8x40 mm	26	1	9300-87	-Lock ring SgA 12
10	1	5844	Locking nut M8	27	1	9339-21	Screw
11	1	9300-170	Digital meter	28	1	5862	Washer
	2	2142	Battery 14 x 50 mm	29	1	9000-102	Wing nut
12	1	9326-162	Crank sensor with cable	30	1	9300-94	Stop
	2	9103-40	Screw for crank sensor	31	2	9300-99	Plastic stop
13	1	9126-75	Screw RXS B8 x 9.5 FZB	32	1	5671-9	Screw M5 x 10 mm
14	1	9326-166	Sensor holder	33	1	9103-62	Brake belt, complete
15	1	9326-263	Cable 620 mm	34	1	9300-92	Washer
	5	9300-66	Holder for cable	35	1	5675-9	Mounting screw
16	1	9300-142	Instrument cover	36	1	9300-3	Flywheel
17	4	5768	Mounting screw for cover	37	2	5799	Nut



Version 1010
Art. No: 7950-296

