

MATRIX
Strong • Smart • Beautiful

T7xe

T7x

T5x

PREMIUM TREADMILL OWNER'S MANUAL

IMPORTANT PRECAUTIONS



SAVE THESE INSTRUCTIONS

When using an electrical product, basic precautions should always be followed, including the following: Read all instructions before using this treadmill. It is the responsibility of the owner to ensure that all users of this treadmill are adequately informed of all warnings and precautions. If you have any questions after reading this guide, contact Customer Tech Support at the number listed on the back panel of the OWNER'S MANUAL.

This product is intended for commercial use. To ensure your safety and protect the equipment, read all instructions before operating.

 **DANGER****TO REDUCE THE RISK OF ELECTRICAL SHOCK:**

Always unplug the treadmill from the electrical outlet immediately after using, before cleaning, performing maintenance and putting on or taking off parts.

 **CAUTION**

If you experience any kind of pain, including but not limited to chest pains, nausea, dizziness, or shortness of breath, stop exercising immediately and consult your physician before continuing.

 **WARNING****TO REDUCE THE RISK OF BURNS, FIRE, ELECTRICAL SHOCK OR INJURY TO PERSONS:**

- If you experience any kind of pain, including but not limited to chest pains, nausea, dizziness, or shortness of breath, stop exercising immediately and consult your physician before continuing.
- When exercising, always maintain a comfortable pace.
- Do not wear clothes that might catch on any part of the treadmill.
- Always wear athletic shoes while using this equipment.
- Do not jump on the treadmill.
- At no time should more than one person be on treadmill while in operation.
- This treadmill should not be used by persons weighing more than specified in the OWNER'S MANUAL SPECIFICATIONS SECTION. Failure to comply will void the warranty.
- Disconnect all power before servicing or moving the equipment. To clean, wipe surfaces down with soap and slightly damp cloth only; never use solvents. (See MAINTENANCE)
- The treadmill should never be left unattended when plugged in. Unplug from outlet when not in use, and before putting on or taking off parts.
- Do not operate under blanket or pillow. Excessive heating can occur and cause fire, electric shock, or injury to persons.
- Connect this exercise product to a properly grounded outlet only.

WARNING

(CONT.)

- At NO time should pets or children under the age of 13 be closer to the treadmill than 10 feet.
- At NO time should children under the age of 13 use the treadmill.
- Children over the age of 13 or disabled persons should not use the treadmill without adult supervision.
- Use the treadmill only for its intended use as described in the treadmill guide and owner's manual.
- Do not use other attachments that are not recommended by the manufacturer. Attachments may cause injury.
- Never operate the treadmill if it has a damaged cord or plug, if it is not working properly, if it has been dropped or damaged, or immersed in water. Call Customer Tech Support for examination and repair.
- Keep power cord away from heated surfaces. Do not carry this unit by its supply cord or use the cord as a handle.
- Never operate the treadmill with the air opening blocked. Keep the air opening clean, free of lint, hair, and the like.
- To prevent electrical shock, never drop or insert any object into any opening.
- Do not operate where aerosol (spray) products are being used or when oxygen is being administered.
- To disconnect, turn all controls to the off position, then remove plug from outlet.
- Do not use treadmill in any location that is not temperature controlled, such as but not limited to garages, porches, pool rooms, bathrooms, car ports or outdoors. Failure to comply may void the warranty.
- Do not remove the console covers unless instructed by Customer Tech Support. Service should only be done by an authorized service technician

It is essential that your treadmill is used only indoors, in a climate controlled room. If your treadmill has been exposed to colder temperatures or high moisture climates, it is strongly recommended that the treadmill is warmed up to room temperature before first time use. Failure to do so may cause premature electronic failure. The initial (default) starting speed is 0.5mph (0.8 km/h). The default starting speed set too high can be dangerous.





ELECTRICAL REQUIREMENTS

For your safety and to ensure good treadmill performance, the ground on this circuit must be non-looped. Please refer to NEC article 210-21 and 210-23. Your Treadmill is provided with a power cord with a plug listed below and requires the listed outlet. Any alterations of this power cord could void all warranties of this product.

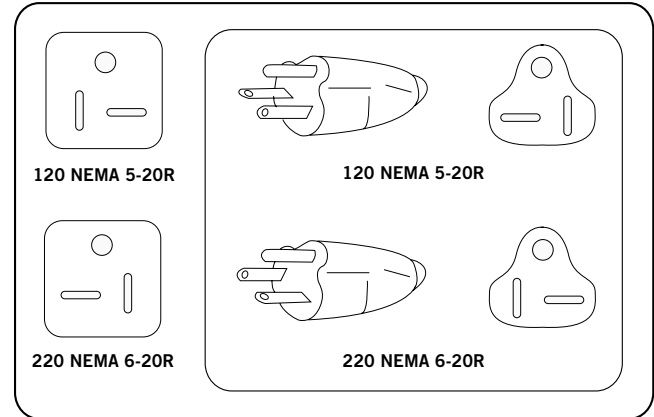

North American power cord plugs shown. Depending on your country, the plug type may vary.

DEDICATED CIRCUIT AND ELECTRICAL INFO

All Matrix units require the use of a 15 amp or 20 amp “dedicated circuit,” with a non-looped (isolated) neutral/ground, for the power requirement. Quite simply this means that each outlet you plug into should not have anything else running on that same circuit. The easiest way to verify this is to locate the main circuit breaker box, and turn off the breaker(s) one at a time. Once a breaker has been turned off, the only thing that should not have power to it are the units in question. No lamps, vending machines, fans, sound systems, or any other item should lose power when you perform this test.

Non-looped (isolated) neutral/grounding means that each circuit must have an individual neutral/ground connection coming from it, and terminating at an approved earth ground. You cannot “jumper” a single neutral/ground from one circuit to the next.

In addition to the dedicated circuit requirement, the proper gauge wire must be used from the circuit breaker box, to each outlet that will have the maximum number of units running off of it. If the distance from the circuit breaker box, to each outlet, is 100 ft or less, then 12 gauge wire may be used. For any distance greater than 100 ft from the circuit breaker box to the outlet, 10 gauge wire must be used.



GROUNDING INSTRUCTIONS

The treadmill must be grounded. If it should malfunction or breakdown, grounding provides a path of least resistance for electric current to reduce the risk of electric shock. The treadmill is equipped with a cord having an equipment-grounding conductor and a grounding plug. The plug must be plugged into an appropriate outlet that is properly installed and grounded in accordance with all local codes and ordinances. If the user does not follow these grounding instructions, the user could void the Matrix limited warranty.



DANGER

Improper connection of the equipment-grounding conductor can result in a risk of electric shock. Check with a qualified electrician or serviceman if you are in doubt as to whether the product is properly grounded. Do not modify the plug provided with the product. If it will not fit the outlet, have a proper outlet installed by a qualified electrician.

120V UNITS

The Matrix T5x, T7x and T7xe 120 treadmill is for use on a nominal 120-volt circuit and has a non-looped grounding plug. Make sure that the 110-volt treadmill is connected to an outlet, NEMA 5-20R, having the same configuration as the plug. No adapter should be used with this product.

220V UNITS

The Matrix T5x, T7x and T7xe 220 treadmill is for use on a nominal 220-volt circuit and has a non-looped grounding plug. Make sure that the 220-volt treadmill is connected to an outlet, NEMA 6-20R, having the same configuration as the plug. No adapter should be used with this product.



WARNING

Connect this exercise product to a properly grounded outlet only.

Never operate product with a damaged cord or plug even if it is working properly. Never operate any product if it appears damaged, or has been immersed in water. Contact Customer Tech Support for replacement or repair.





BASIC OPERATION





LOCATION OF THE TREADMILL

Place the treadmill on a level and stable surface. Please leave a clear zone behind the treadmill that is at least the width of the treadmill and at least 79" (2000 mm) long. This zone must be clear of any obstruction and provide the user a clear exit path from the machine. In case of an emergency, place both hands on the side arm rests to hold yourself up and place your feet onto the side rails. For ease of access, there should be an accessible space preferentially on both sides of the treadmill equal to 36" (915 mm) to allow a user access to the treadmill from either side. Do not place the treadmill in any area that will block any vent or air openings. The treadmill should not be located in a garage, covered patio, near water or outdoors.

CAUTION - RISK OF INJURY TO PERSONS

While you are preparing to use the treadmill, do not stand on the belt. Place your feet on the side rails before starting the treadmill. Start walking on the belt only after the belt has begun to move. Never start the treadmill at a fast running speed and attempt to jump on!

USING THE SAFETY KEY

Your treadmill will not start unless the stop button is reset. Attach the clip end securely to your clothing. This safety key is designed to cut the power to the treadmill if you should fall. Check the operation of the safety key every 2 weeks.

WARNING

Never use the treadmill without securing the safety key clip to your clothing. Pull on the safety key clip first to make sure it will not come off your clothing.

PROPER USAGE

Your treadmill is capable of reaching high speeds. Always start off using a slower speed and adjust the speed in small increments to reach a higher speed level. Never leave the treadmill unattended while it is running. When not in use turn the on/off switch to off and unplug the power cord. Make sure to follow the MAINTENANCE schedule in this guide to maintain optimal performance and prevent premature electronic failure. Keep your body and head facing forward. Do not attempt to turn around or look backwards while the treadmill is running. Stop your workout immediately if you feel pain, faint, dizzy or are short of breath.

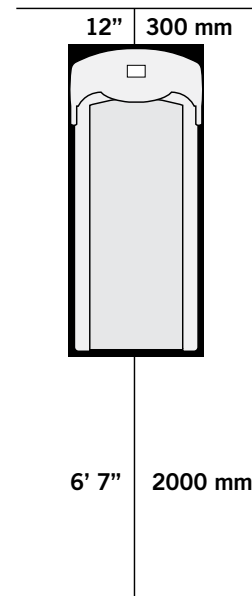

LEVELING THE TREADMILL

Use of shim or adding leveling foot.

NOTE: It is extremely important that the levelers are correctly adjusted for proper operation. An unbalanced unit may cause belt misalignment or other issues. Use of a level is recommended.

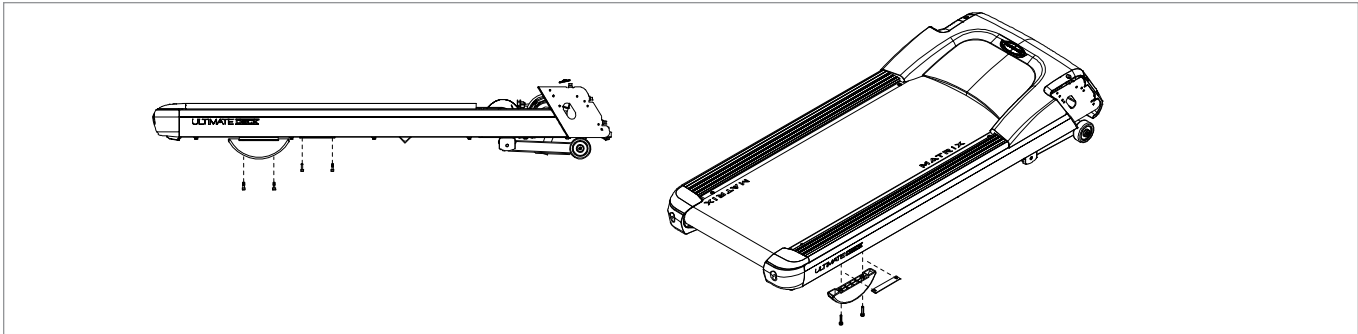

Remove the leveling shim provided on the underside of the treadmill. The shim can be found mounted on the underside of the right hand side rail. Remove the rear foot on the side of the treadmill that is resting low. Install the shim as shown above and return the rear foot.

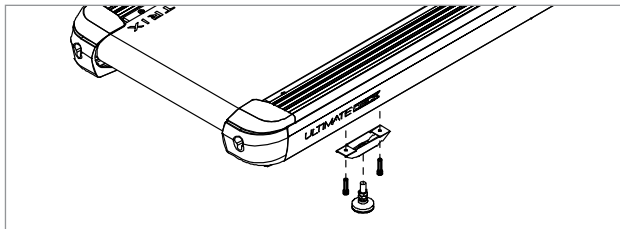

When installing the optional rear leveling foot accessory, remove the existing rear foot. Replace with new leveling foot and fasten to the frame using the existing fasteners that held in the half-moon foot.

WARNING

Our Treadmills are heavy, use care and additional help if necessary when moving.

TENSIONING THE RUNNING BELT



After placing the treadmill in the position it will be used, the belt must be checked for proper tension and centering. The belt might need to be adjusted after the first two hours of use. Temperature, humidity, and use cause the belt to stretch at different rates. If the belt starts to slip when a user is on it, be sure to follow the directions below.

- A Locate the two hex head bolts on the rear of the treadmill. The bolts are located at each end of the frame at the back of the treadmill. These bolts adjust the rear belt roller. Do not adjust until the treadmill is on. This will prevent over tightening of one side.
- B The belt should have equal distance on either side between the frame. If the belt is touching one side, do not start the treadmill. Turn the bolts counter clockwise approximately one full turn on each side. Manually center the belt by pushing the belt from side to side. Tighten the bolts the same amount as when the user loosened them, approximately one full turn. Inspect the belt for damage.
- C While the treadmill is running at 3 mph, observe the belt position. If it is moving to the right, tighten the right bolt by turning it clockwise $\frac{1}{4}$ turn, and loosen the left bolt $\frac{1}{4}$ turn. If it is moving to the left, tighten the left bolt by turning it clockwise $\frac{1}{4}$ turn and loosen the right $\frac{1}{4}$ turn. Repeat Step 3 until the belt remains centered for several minutes.
- D Check the tension of the belt. The belt should be very snug. When a person walks or runs on the belt, it should not hesitate or slip. If this occurs, tighten the belt by turning both bolts clockwise $\frac{1}{4}$ turn. Repeat if necessary.

NOTE: Use the orange strip in the lateral position of the side rails as criteria to confirm the belt is properly centered. It is necessary to adjust the belt until the edge of the belt is parallel to the orange or white strip.

CAUTION

Do not run belt faster than 1 mph while centering. Keep fingers, hair and clothing away from belt at all times.

Treadmills equipped with side handrails and front handlebar for user support and emergency dismount, press emergency button to stop the machine for emergency dismount.

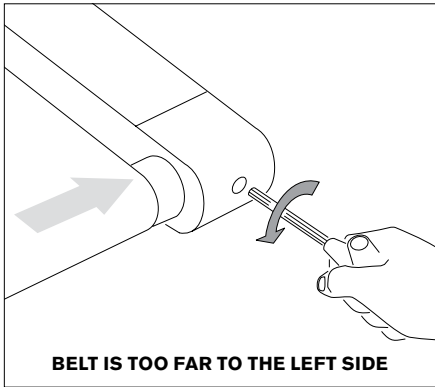
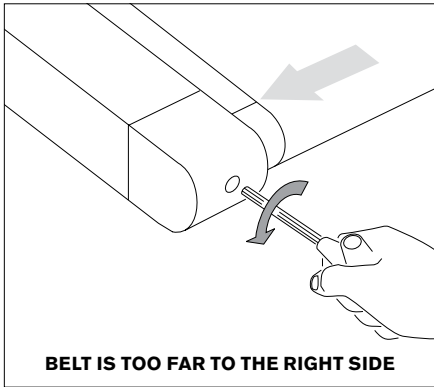
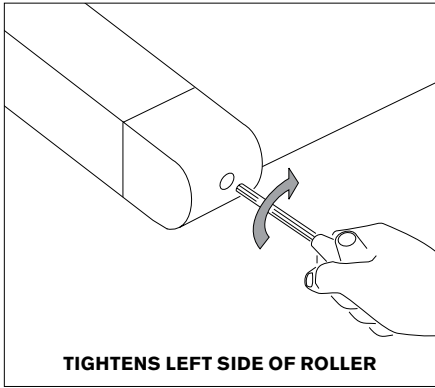
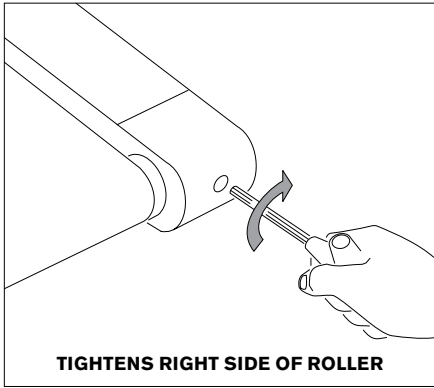

USING THE HEART RATE FUNCTION



Your unit could be equipped with a heart rate pulse grip.

The heart rate function on this product is not a medical device. While heart rate grips can provide a relative estimation of your actual heart rate, they should not be relied on when accurate readings are necessary. Some people, including those in a cardiac rehab program, may benefit from using an alternate heart rate monitoring system like a chest or wrist strap. Various factors, including movement of the user, may affect the accuracy of your heart rate reading. The heart rate reading is intended only as an exercise aid in determining heart rate trends in general. Please consult your physician.

PULSE GRIPS

Place the palm of your hands directly on the grip pulse handlebars. Both hands must grip the bars for your heart rate to register. It takes 5 consecutive heart beats (15-20 seconds) for your heart rate to register. When gripping the pulse handlebars, do not grip tightly. Holding the grips tightly may elevate your blood pressure. Keep a loose, cupping hold. You may experience an erratic readout if consistently holding the grip pulse handlebars. Make sure to clean the pulse sensors to ensure proper contact can be maintained.

WIRELESS HEART RATE RECEIVER

When used in conjunction with a **wireless chest transmitter**, your heart rate can be transmitted wirelessly to the unit and displayed on the console.

Prior to wearing the wireless chest transmitter on your chest, moisten the two rubber electrodes with water. Center the chest strap just below the breast or pectoral muscles, directly over your sternum, with the logo facing out. **NOTE:** The chest strap must be tight and properly placed to receive an accurate and consistent readout. If the chest strap is too loose, or positioned improperly, you may receive an erratic or inconsistent heart rate readout.

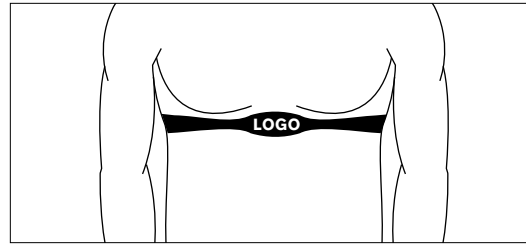
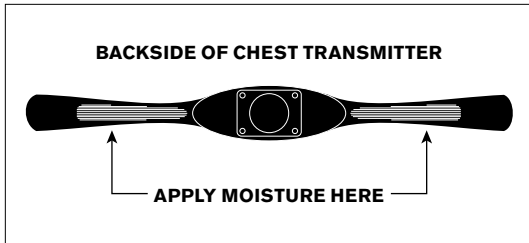

WARNING!

Heart rate monitoring systems may be inaccurate. Over exercising may result in serious injury or death. If you feel faint, stop exercising immediately.



TROUBLESHOOTING & MAINTENANCE



RECOMMENDED CLEANING TIPS

- A Use a soft, clean cotton cloth. DO NOT use paper towels to clean surfaces on the treadmill. Paper towels are abrasive and can damage surfaces.
- B Use a mild soap and damp cloth. DO NOT use ammonia based cleaner. This will cause discoloring of the aluminum and plastics it comes into contact with.
- C Do not pour water or cleaning solutions on any surface. This could cause electrocution.
- D Wipe the console and side rails after every use.
- E Brush away any wax deposits from the deck and belt area. This is a common occurrence until the wax is worked into the belt material.
- F Be sure to remove any obstructions from the path of the elevation wheels including power cords.
- G Monthly, unplug the treadmill and remove the motor cover. Check for debris and clean with a dry cloth or small vacuum nozzle.
- H For cleaning 7xe displays, use distilled water in an atomizer spray bottle. Spray distilled water onto soft, clean, dry cloth and wipe display until clean and dry. For very dirty displays, adding vinegar is recommended.

WARNING: Do not plug the treadmill in until the motor cover has been reinstalled.

CAUTION: Be sure to have proper assistance to install and move the unit in order to avoid injury or damage to the treadmill.

DECK AND BELT REPLACEMENT

One of the most common wear and tear items on a treadmill is the deck and belt combination. If these two items are not properly maintained they can cause damage to other components. This product has been provided with the most advanced maintenance free lubricating system on the market. The Matrix Ultimate Deck™ does not require any maintenance, other than cleaning and belt tightening, for up to 25,000 miles.

WARNING: Do not run the treadmill while cleaning the belt and deck. This can cause serious injury and can damage the machine.

Maintain the belt and deck by wiping the sides of the belt and deck with a clean cloth. The user can also wipe under the belt 2 inches on both sides removing any dust or debris.

The deck can be flipped and reinstalled or replaced by an authorized service technician. Please contact Matrix Fitness Systems for more information.

WARNING

To remove power from the treadmill, the power cord must be disconnected from the wall outlet.

CHECK FOR DAMAGED PARTS

DO NOT use any equipment that is damaged or has worn or broken parts. Use only replacement parts supplied by Matrix Fitness Systems.

MAINTAIN LABELS AND NAMEPLATES Do not remove labels for any reason. They contain important information. If unreadable or missing, contact Matrix Fitness Systems for a replacement or an authorized service provider.

MAINTAIN ALL EQUIPMENT Preventative maintenance is the key to smooth operating equipment, as well as keeping the user's liability to a minimum. Equipment needs to be inspected at regular intervals. Defective components must be replaced immediately. Improperly working equipment must be kept out of use until it is repaired. Ensure that any person(s) making adjustments or performing maintenance or repair of any kind is qualified to do so. Matrix Fitness Systems will provide service and maintenance training at our corporate facility upon request or in the field if proper arrangements are made.

CARE AND MAINTENANCE

HOW DO I CLEAN MY MACHINE?

Clean with soap and water cleaners only. Never use solvents on plastic parts. Cleanliness of your treadmill and its operating environment will keep maintenance problems and service calls to a minimum. For this reason, Customer Tech Support recommends that the following preventive maintenance schedule be followed.

DAILY

- Clean entire machine using water and mild detergent such as "Simple Green", or other Matrix approved solution (cleaning agents should be alcohol and ammonia free).



TREADMILL ASSEMBLY



WARNING

There are several areas during the assembly process that special attention must be paid. It is very important to follow the assembly instructions correctly and to make sure all parts are firmly tightened. If the assembly instructions are not followed correctly, the treadmill could have parts that are not tightened and will seem loose and may cause irritating noises. To prevent damage to the treadmill, the assembly instructions must be reviewed and corrective actions should be taken.

Before proceeding, find your treadmill's serial number located on a white barcode sticker near the on/off power switch and power cord and enter it in the space provided below.

ENTER YOUR SERIAL NUMBER AND MODEL NAME IN THE BOXES BELOW:

CONSOLE SERIAL NUMBER*:

<input type="text"/>	<input type="text"/>
----------------------	----------------------

FRAME SERIAL NUMBER:

<input type="text"/>	<input type="text"/>
----------------------	----------------------

MODEL NAME: **MATRIX**

<input type="text"/>

SERIAL NUMBER LOCATION

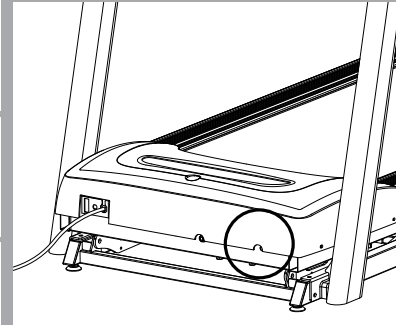

» Refer to the SERIAL NUMBER and MODEL NAME when calling for service.











*The console serial number can be found in the Manager Mode.



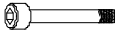





REQUIRED FASTENERS



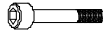

	Part #:	Part Name:	Outline:	Dimensions:	Quantity:	Bag Color:
10	020090-00	SOCKET HEAD CAP SCREW		M8 x 20mm	10	BLACK
14	0000086571	FLAT WASHER		8.2 x 16 x 2.0T	10	BLACK
20	0000084935	LEFT CONNECTION BRACKET		SPHC 4.0T	1	
21	0000084936	RIGHT CONNECTION BRACKET		SPHC 4.0T	1	
11	004541-AC	SOCKET HEAD CAP SCREW		M8 x 1.25P x 45 mm	2	WHITE
12	035882-AB	SOCKET HEAD CAP SCREW		M8 x 1.25P x 75 mm	4	WHITE
14	0000086571	FLAT WASHER		8.2 x 16 x 2.0T	6	WHITE
17	004539-AD	SOCKET HEAD CAP SCREW		M8 x 1.25P x 25mm	2	BLUE
19	0000088905	SPACER		M8 x 16 x 8	2	BLUE
15	004859-AC	BUTTON SOCKET HEAD CAP SCREW		M8 x 1.25 x 20 mm	6	RED
14	0000086571	FLAT WASHER		8.2 x 16 x 2.0T	6	RED

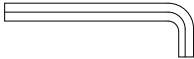
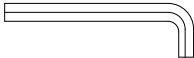
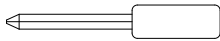

13	020072-00	SOCKET HEAD CAP SCREW		M8 x 1.25 x 60mm	4	YELLOW
16	062769-00	SOCKET HEAD CAP SCREW		M8 x 1.25 x 15mm	2	YELLOW
23	0000089835	RIBBED LOCK WASHER		8.5 x 12.8 x .8/1.3H	6	YELLOW
	005394-00	T-SHAPED WRENCH		8mm x 186L	1	

REQUIRED TOOLS

SKETCH	DESCRIPTION	QUANTITY	PAKEAGE COLOR
	6mm ALLEN WRENCH	1	PURPLE
	5mm ALLEN WRENCH	1	PURPLE
	PHILLIPS DRIVER(6x130mm)	1	PURPLE
	8mm ALLEN WRENCH	1	PURPLE

ASSEMBLY STEP 1

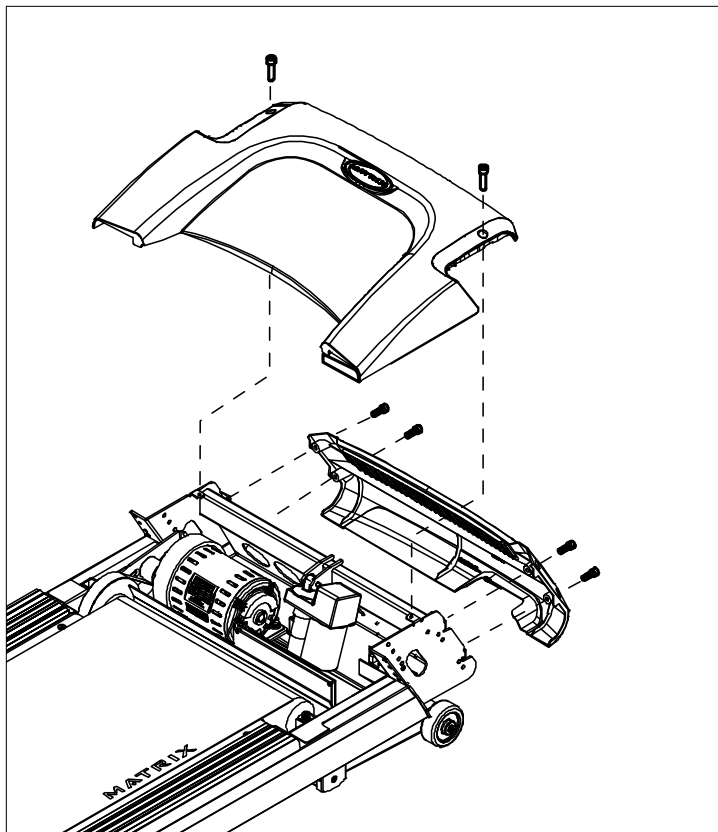

- A Cut the yellow banding straps and lift the running deck upward to remove all contents from underneath the running deck.
- B Open **HARDWARE BAG 1**.
- C Slide **MAIN FRAME BOOT** up **CONSOLE MAST**. Place **RIGHT CONSOLE MAST** over **MAIN FRAME BRACKET**.
- D Pull **LEAD WIRE** through **RIGHT CONSOLE MAST**. After pulling the **LEAD WIRE** through the mast, the top of the **CONSOLE CABLE** should be located at the top of the mast. Detach and discard **LEAD WIRE**.

NOTE: Do not pinch **CONSOLE CABLE** when placing the mast onto the **MAIN FRAME BRACKET**.

- E Attach **CONSOLE MAST** to **MAIN FRAME BRACKET** using 3 **BOLTS (A)**, 3 **SPRING WASHERS (B)** and 3 **ARC WASHERS (C)**.

NOTE: Do not tighten bolts until step 3 is complete.

- F Slide **MAIN FRAME BOOT** down over **MAIN FRAME BRACKET**.
- G Repeat steps D–F on other side.



ASSEMBLY STEP 2

BLACK HARDWARE BAG CONTENTS :

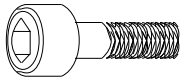

10
SOCKET HEAD CAP SCREW (M8 x 20mm)
Qty: 10



14
FLAT WASHER (6.2 x 12 x 1.6)
Qty: 10

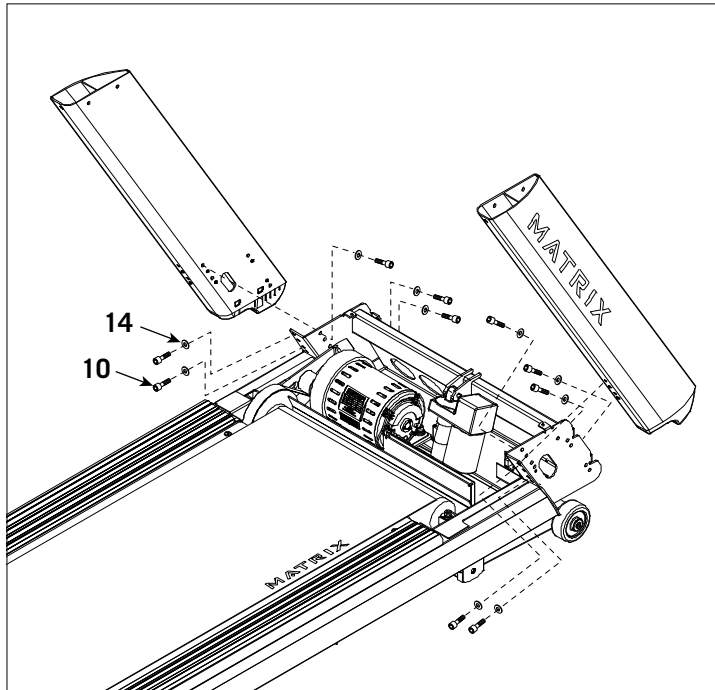

- A Open **HARDWARE BAG 2**.
- B With the **CONSOLE** upside down, attach the **CONSOLE MAST CAPS** to the **CONSOLE** using 4 **BOLTS (E)** and 4 **SPRING WASHERS (B)**.

NOTE: The console mast caps are marked with an L if they are to be used on the left-hand side of the treadmill or an R if they are to be used on the right-hand side of the treadmill. If the console mast caps are assembled on the incorrect side of the treadmill, the unit will not assemble correctly.



ASSEMBLY STEP 3

WHITE HARDWARE BAG CONTENTS :

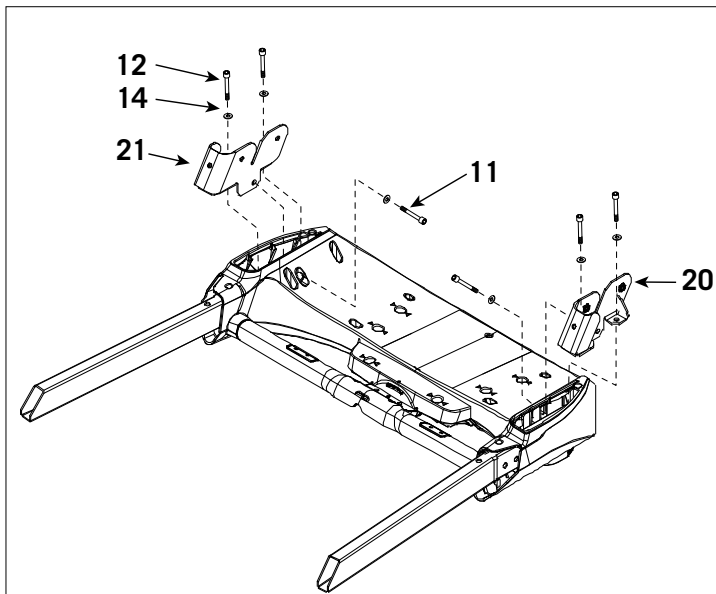
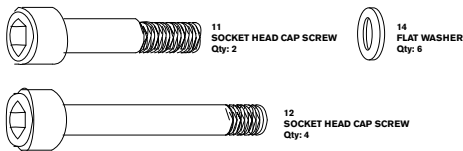

- A Open **HARDWARE BAG 3**.
- B Slide **CONSOLE** through the **CONSOLE MAST BOOTS**.

NOTE: Make sure the arrows on the mast rings are pointing upward towards the console when sliding into place.

- C Connect **CONSOLE CABLES**.

NOTE: Be careful not to pinch any wires while assembling the right console mast.

- D Connect **CONSOLE** to **RIGHT CONSOLE MAST** using 2 **BOLTS (A)**, 2 **SPRING WASHERS (B)** and 2 **ARC WASHERS (C)**.
- E Repeat on other side.
- F Fold the deck into the upright position until the foot latch engages. Rotate the **CONSOLE MASTS** until the spacing between the handlebars and the deck are the same. Tighten **BOLTS** from step 1 and then step 3.



ASSEMBLY STEP 4

BLUE HARDWARE BAG CONTENTS :

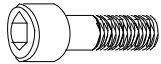

17
SOCKET HEAD CAP SCREW
Qty: 2



19
SPACER
Qty: 2

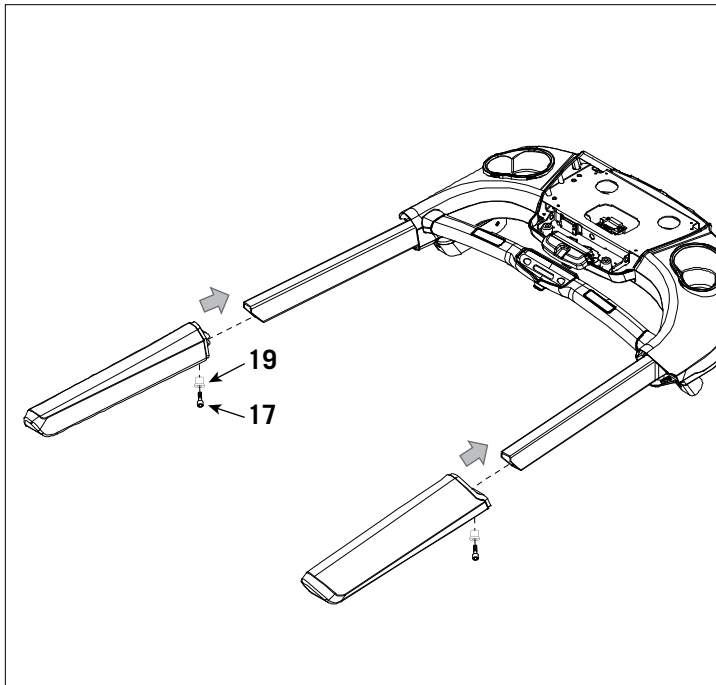

- A Open **HARDWARE BAG 4**.
- B Attach **MAIN FRAME BOOTS** using 4 **SCREWS (D)**.
- C Before the first use, lubricate the treadmill deck by following the instructions in the **MAINTENANCE** section in the **TREADMILL GUIDE**.



ASSEMBLY STEP 5

RED HARDWARE BAG CONTENTS :

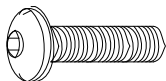

15
BUTTON SOCKET HEAD CAP SCREW
Qty: 6



14
FLAT WASHER
Qty: 6

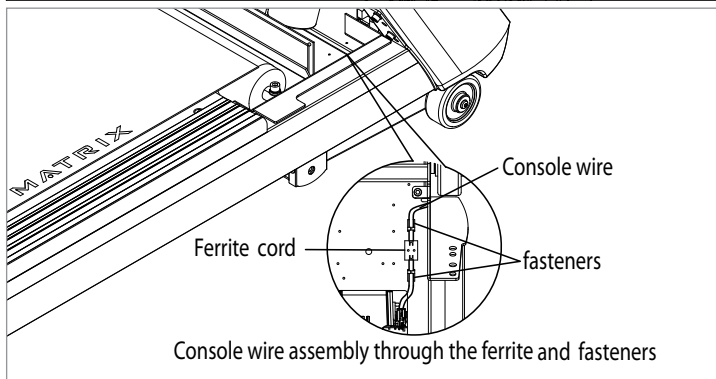
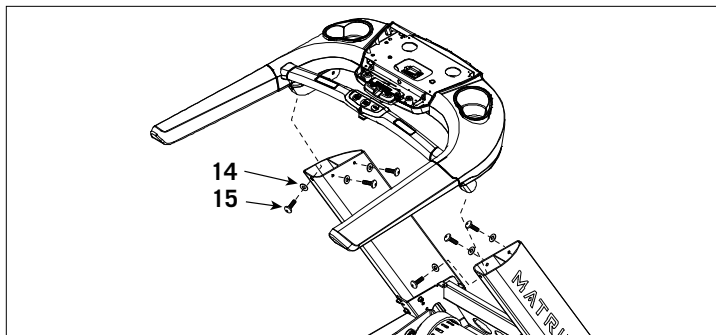

- A Open **HARDWARE BAG 3**.
 - B Slide **CONSOLE** through the **CONSOLE MAST BOOTS**.
- NOTE: Make sure the arrows on the mast rings are pointing upward towards the console when sliding into place.
- C Connect **CONSOLE CABLES**.
- NOTE: Be careful not to pinch any wires while assembling the right console mast.
- D Connect **CONSOLE** to **RIGHT CONSOLE MAST** using 2 **BOLTS (A)**, 2 **SPRING WASHERS (B)** and 2 **ARC WASHERS (C)**.
 - E Repeat on other side.
 - F Fold the deck into the upright position until the foot latch engages. Rotate the **CONSOLE MASTS** until the spacing between the handlebars and the deck are the same. Tighten **BOLTS** from step 1 and then step 3.



ASSEMBLY STEP 6

YELLOW HARDWARE BAG CONTENTS :

 **13**
SOCKET HEAD CAP SCREW
Qty: 4

 **23**
RIBBED LOCK WASHER
Qty: 6

 **16**
SOCKET HEAD CAP SCREW
Qty: 2

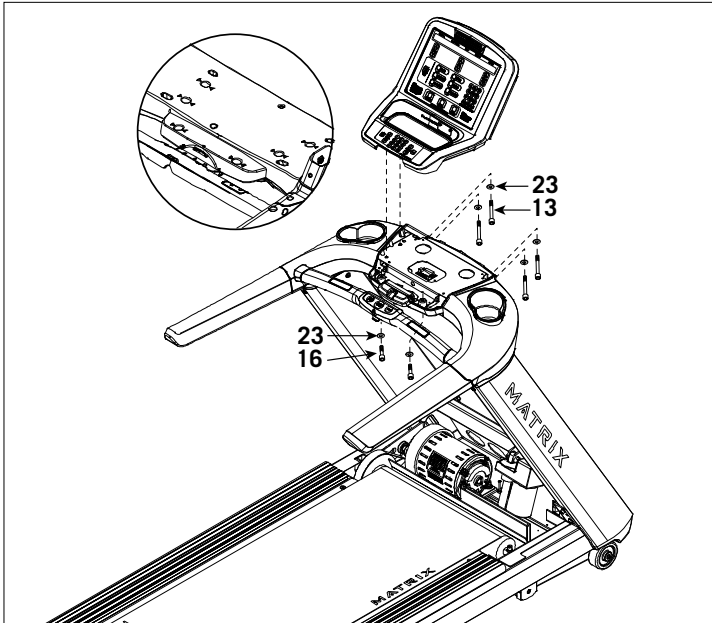

- A Open **HARDWARE BAG 4**.
- B Attach **MAIN FRAME BOOTS** using 4 **SCREWS (D)**.
- C Before the first use, lubricate the treadmill deck by following the instructions in the **MAINTENANCE** section in the **TREADMILL GUIDE**.



ASSEMBLY STEP 7

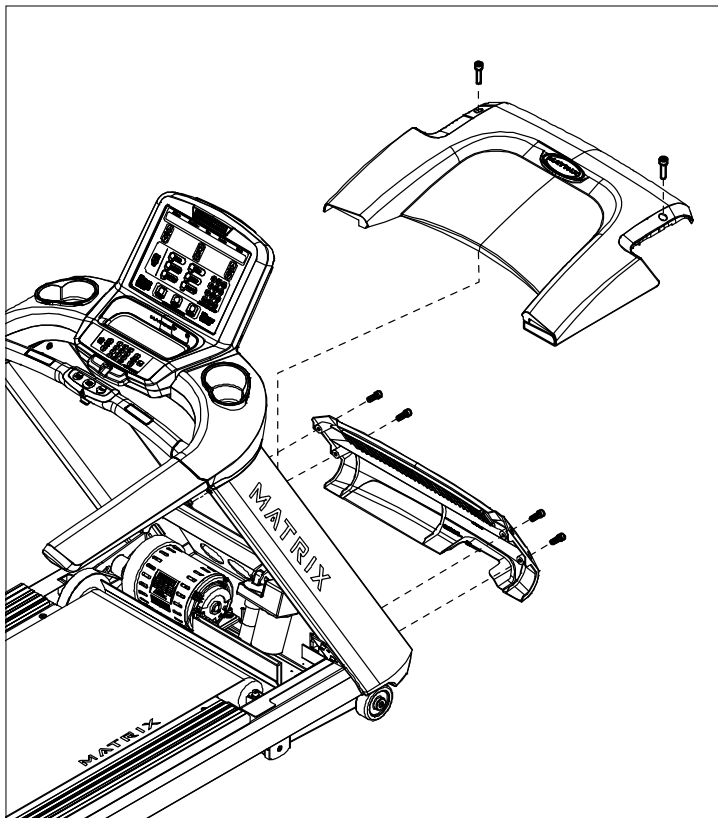

- A Open **HARDWARE BAG 4**.
- B Attach **MAIN FRAME BOOTS** using 4 **SCREWS (D)**.
- C Before the first use, lubricate the treadmill deck by following the instructions in the **MAINTENANCE** section in the **TREADMILL GUIDE**.

ASSEMBLY COMPLETE!

TREADMILL OPERATION



MANAGER PREFERENCE MODE



3X AND 5X CONSOLES:

This section allows a user to manipulate default settings for the machines. It may be accessed by pressing the **Level Up/Level Down** keys simultaneously for 5 seconds. To change a setting, press **“Enter”** on the keypad and use the Level buttons and numeric keypad to change the values. Pressing **“Enter”** again will save the change. Pressing **“Back”** will bring you to the previous menu. To exit manager’s mode, hold **“Stop”** down for 5 seconds. Below is a list of the settings.

3XE, 7X AND 7XE CONSOLES:

This section allows a user to manipulate default settings for the machines. It may be accessed by pressing **“ENTER”, 1, 0, 0, 1, “Enter”**. To change a setting, press **“Enter”** on the keypad and use the Level buttons and numeric keypad to change the values. Pressing **“Enter”** again will save the change. Pressing **“Back”** will bring you to the previous menu. To exit manager’s mode, press the **“Home”** key. Below is a list of the settings.

Maximum Time	Default Incline
Default Time	Speed/Distance Mode
Default Level	Out of Order
Default Age	Gender
Default Weight	Language
Accumulated Distance	Sound Mode
Accumulated Time	Incline Reset
Software Version	
Timer Mode	



CONSOLE DESCRIPTION:

The Matrix machine is inspected before it is packaged. It is shipped in two pieces: the base and the console. Carefully unpack the unit and dispose of the box material.



T5X CONSOLE DESCRIPTION

Note: There is a thin protective sheet of clear plastic on the overlay of the console that should be removed before use.



- A) **WORKOUT KEYS:** Simple program view and selection buttons. Press Fitness Test button to cycle through available tests.
- B) **QUICK START/GO:** One Touch Start and Quick Start.
- C) **ENTER:** To confirm each program setting.
- D) **UP/DOWN INCLINE:** Easy information and incline selection.
- E) **UP/DOWN SPEED:** Easy information and speed selection.
- F) **UP/DOWN TIME:** Easy information and time adjustment.
- G) **EMERGENCY STOP / IMMOBILIZATION:** To stop all functions and immobilize the unit. The emergency stop on this treadmill must be returned to its original position in order to allow normal operation of the unit.
- H) **STOP:** Ends workout and shows workout summary data.
- I) **PAUSE:** Pauses workout. Pause duration can be set in manager mode.
- J) **NUMBER KEYPAD:** Workout data input for workout setup. Speed adjustment during workout.
- K) **COOL DOWN:** Puts treadmill into Cool Down mode. Cool Down time is dependent on the length of the workout. Workouts 19 minutes and shorter will have a cool down length of 2 minutes. Workouts 20 minutes and longer will have a cool down length of 5 minutes.
- L) **FAN:** Allows for fan speed selection (fan has three operating speeds.)
- M) **TOGGLE DISPLAY:** Changes between top and bottom row of workout information.



T7X CONSOLE DESCRIPTION

Note: There is a thin protective sheet of clear plastic on the overlay of the console that should be removed before use.



- A) **MULTI-PURPOSE KEYS:** Keys have different functions depending on each screen.
- B) **QUICK START/GO:** One Touch Start and Quick Start.
- C) **ENTER:** To confirm each program setting.
- D) **UP/DOWN INCLINE:** Easy information and incline selection.
- E) **UP/DOWN SPEED:** Easy information and speed selection.
- F) **UP/DOWN TIME:** Easy information and time adjustment.
- G) **EMERGENCY STOP / IMMOBILIZATION:** To stop all functions and immobilize the unit. The emergency stop on this treadmill must be returned to its original position in order to allow normal operation of the unit.
- H) **STOP:** Ends workout and shows workout summary data.
- I) **PAUSE:** Pauses workout. Pause duration can be set in manager mode.
- J) **NUMBER KEYPAD:** Workout data input for workout setup. Speed adjustment during workout.
- K) **COOL DOWN:** Puts treadmill into Cool Down mode. Cool Down time is dependent on the length of the workout. Workouts 19 minutes and shorter will have a cool down length of 2 minutes. Workouts 20 minutes and longer will have a cool down length of 5 minutes.
- L) **FAN:** Allows for fan speed selection (fan has three operating speeds.)

T7X ENTERTAINMENT ZONE

- K) **POWER:** If add-on TV is present, acts as the power control button. If add-on TV is not present, acts as a display toggle button.
- L) **IPOD®:** Will take the user directly to the iPod screen to allow for iPod control and playlist selection.
- M) **VOLUME UP/DOWN:** Adjusts the volume output through the headphone jack of either add-on TV, integrated console TV or iPod output.
- N) **NUMBER KEYPAD:** Allows for easy TV channel selections. These buttons work for either the add-on TV or the integrated console TV.
- O) **CHANNEL UP/DOWN:** Allows for channel selection on either the add-on TV or the integrated console TV.
- P) **DISPLAY MODE:** Allows user to cycle through console display options, iPod, TV or profile display.
- Q) **LAST CHANNEL:** Allows the user to cycle between the current channel and the previous channel they were viewing.



T7XE CONSOLE DESCRIPTION

The T7xe has a full integrated touch screen display. All information required for workouts is explained on screen. Exploration of the interface is highly encouraged. The information explaining how to program for various workouts will give an explanation about the contents of each screen on the T7xe.



- A) QUICK START/GO:** One Touch Start and Quick Start.
- B) STOP:** Ends workout and shows workout summary data.
- C) COOL DOWN:** Puts treadmill into Cool Down mode. Cool Down time is dependent on the length of the workout. Workouts 19 minutes and shorter will have a cool down length of 2 minutes. Workouts 20 minutes and longer will have a cool down length of 5 minutes.
- D) EMERGENCY STOP / IMMOBILIZATION:** To stop all functions and immobilize the unit. The emergency stop on this treadmill must be returned to its original position in order to allow normal operation of the unit.

T7XE ENTERTAINMENT ZONE

- E) POWER:** If add-on TV is present, acts as the power control button. If add-on TV is not present, acts as a display toggle button.
- F) IPOD@:** Will take the user directly to the iPod screen to allow for iPod control and playlist selection.
- G) VOLUME UP/DOWN:** Adjusts the volume output through the headphone jack of either add-on TV, integrated console TV or iPod output.
- H) NUMBER KEYPAD:** Allows for easy TV channel selections. These buttons work for either the add-on TV or the integrated console TV.
- I) CHANNEL UP/DOWN:** Allows for channel selection on either the add-on TV or the integrated console TV.
- J) DISPLAY MODE:** Allows user to cycle through console display options, iPod, TV or profile display.
- K) LAST CHANNEL:** Allows the user to cycle between the current channel and the previous channel they were viewing.

WORKOUT DESCRIPTIONS

QUICK START OPERATION

Press the **GO** or **QUICK START** button(s) and the treadmill will enter into a manual mode of operation. All energy expenditure values will be calculated using the default weight measurement.

MANUAL WORKOUT OPERATION

Manual is a workout that allows you to manually adjust the speed and incline values at anytime. The manual workout also contains a setup screen which allows you to input your weight to help calculate a more accurate caloric burn rate.

To enter into this workout on a 5x, use the following guidelines:

- 1) Choose **MANUAL** by selecting the manual workout button and press **ENTER**.
- 2) Enter the desired workout length using the **ARROW KEYS** or the **NUMBER KEYPAD** and press **ENTER**.
- 3) Enter user weight (user weight is used to calculate the caloric expenditure value-providing an accurate weight helps to ensure an accurate caloric expenditure rating for each user) using the **ARROW KEYS** or the **NUMBER KEYPAD** and press **ENTER**.
- 4) Enter the desired initial level using the **ARROW KEYS** or the **NUMBER KEYPAD** and press **ENTER**.

To enter into this workout on a 7x or 7xe, follow the onscreen prompts.

LEVEL BASED PROGRAMS

Your Matrix treadmill offers a variety of level-based workouts to challenge users of all fitness levels. The following information will briefly explain the workout and how to program the treadmill for each workout selection.

ROLLING HILLS WORKOUT OPERATION

Rolling hills is a level-based workout that automatically adjusts the resistance value to simulate walking or running up hills.

- 1) Choose **ROLLING HILLS** by selecting the rolling hills workout button and press **ENTER**.
- 2) Enter the desired intensity using the **ARROW KEYS** or the **NUMBER KEYPAD** and press **ENTER**.
- 3) Enter the desired workout length using the **ARROW KEYS** or the **NUMBER KEYPAD** and press **ENTER**.
- 4) Enter user weight (user weight is used to calculate the caloric expenditure value-providing an accurate weight helps to ensure an accurate caloric expenditure rating for each user) using the **ARROW KEYS** or the **NUMBER KEYPAD** and press **ENTER**.
- 5) Press **GO** or **QUICK START** to begin the workout.

To enter into this workout on a 7x or 7xe, follow the onscreen prompts.





FAT BURN WORKOUT OPERATION

Fat burn is a level-based workout that is designed to help users burn fat through various resistance changes.

To enter into this workout on a 5x, use the following guidelines:

- 1) Choose **FAT BURN** by selecting the fat burn workout button and press **ENTER**.
- 2) Enter the desired intensity level using the **ARROW KEYS** or the **NUMBER KEYPAD** and press **ENTER**.
- 3) Enter the desired workout length using the **ARROW KEYS** or the **NUMBER KEYPAD** and press **ENTER**.
- 4) Enter user weight (user weight is used to calculate the caloric expenditure value-providing an accurate weight helps to ensure an accurate caloric expenditure rating for each user) using the **ARROW KEYS** or the **NUMBER KEYPAD** and press **ENTER**.
- 5) Press **GO** or **QUICK START** to begin the workout.

To enter into this workout on a 7x or 7xe, follow the onscreen prompts.

HEART RATE CONTROL WORKOUT OPERATION

Your Matrix treadmill offers a heart rate control workout mode. The heart rate control workout mode allows the user to program their desired heart rate zone and maximum allowable incline and the treadmill will automatically adjust the incline based upon the user's heart rate. The heart rate zone is calculated using the following equation: $(220 - \text{Age}) \times \% = \text{target heart rate zone}$. The user must wear a telemetric heart rate monitor or continually hold onto the contact heart rate grips for this workout.

To enter into this workout on a 5x, use the following guidelines:

- 1) Choose **TARGET HEART RATE** by selecting the target heart rate workout button and press **ENTER**.
- 2) Enter age using the **ARROW KEYS** or the **NUMBER KEYPAD** and press **ENTER**.
- 3) Enter the desired percent of maximum heart rate using the **ARROW KEYS** and press **ENTER**.
- 4) Enter the desired workout length using the **ARROW KEYS** or the **NUMBER KEYPAD** and press **ENTER**.
- 5) Enter user weight (user weight is used to calculate the caloric expenditure value-providing an accurate weight helps to ensure an accurate caloric expenditure rating for each user) using the **ARROW KEYS** or the **NUMBER KEYPAD** and press **ENTER**.
- 6) Press **GO** or **QUICK START** to begin the workout.

To enter into this workout on a 7x or 7xe, follow the onscreen prompts.

WORKOUT DESCRIPTIONS

FIT TEST

Your Matrix treadmill offers a variety of fitness tests—the Gerkin firefighter protocol, the WFI firefighter protocol, the Army, Navy, USMC, and USAF as well as the Physical Efficiency Battery (PEB).

The Gerkin protocol was developed by Dr. Richard Gerkin of the Phoenix (Arizona) Fire Department. It is a sub-maximal graded treadmill evaluation used by many Fire Departments across the United States to assess the physical condition of the firefighters. The test requires constant monitoring of the user's heart rate so the use of a telemetric chest strap is highly encouraged. The workout operates as follows:

WARM-UP: The warm-up is 3 minutes long and runs at 3.0 mph (4.8 kph) and 0% incline.

STAGE 1: At the 3 minute mark, the treadmill will gradually increase speed to 4.5 mph (7.2 kph). The actual test begins at 4.5 mph (7.2 kph).

STAGE 2: After one minute, the treadmill incline will increase to 2%.

STAGE 3: After one minute, the treadmill speed increases to 5.0 mph (8.0 kph).

STAGES 4 THROUGH 11: After every odd minute, the treadmill incline will increase by 2%. After every even minute, the treadmill speed will increase by 0.5 mph (0.8 kph). Once the user's heart rate exceeds the target heart rate (85% of maximum as determined by the equation $(220 - \text{Age}) \times 0.85 = \text{target heart rate zone}$), the individual continues the evaluation for an additional 15 seconds. During the 15 second period, the evaluation remains at the stage where the target heart rate is exceeded, without any change to speed or incline. If the heart rate does not return to or below the target heart rate, the evaluation ends and the final evaluation stage is recorded. If the heart rate returns to or below the target heart rate, the program continues at the point where it would have been had the program not stabilized for 15 seconds.

TEST COMPLETION: The test is completed when user heart rate exceeds the target for more than 15 seconds or the user completes all 11 stages, whichever occurs first. The treadmill will enter a cool down cycle for 3 minutes at 3.0 mph (4.8 kph), 0% incline.





To enter into this workout on a T5x, use the following guidelines:

- 1) Choose the Gerkin test by pressing the Fitness Test workout button until Gerkin is shown in the message window and press **ENTER**.
- 2) Enter age using the **ARROW KEYS** or the **NUMBER KEYPAD** and press **ENTER**
- 3) The message window will display your target heart rate based upon your age and the target heart rate zone of 85%.
- 4) Select gender using the **ARROW KEYS** and press **ENTER**.
- 5) Enter user weight (user weight is used to calculate the caloric expenditure value-providing an accurate weight helps to ensure an accurate caloric expenditure rating for each user) using the **ARROW KEYS** or the **NUMBER KEYPAD** and press **ENTER**.
- 6) The message window will notify the user that the start speed is 3.0 mph (4.8 kph) and 0% incline during the warm-up.
- 7) Press **GO** or **QUICK START** to begin the workout.

To enter into the Gerkin testing workout on a T7x or a T7xe, follow the onscreen prompts.

Submaximal treadmill evaluation conversion table

Males:	VO2 max (ml/kg/min)			
	20-29	30-39	40-49	50-59
SUPERIOR	>58.8	>58.9	>55.4	>52.5
	54.0	52.5	50.4	47.1
EXCELLENT	51.4	50.3	48.2	45.3
	48.2	46.8	44.1	41.0
GOOD	46.8	44.6	41.8	38.5
	44.2	42.4	39.9	36.7
FAIR	42.5	41.0	38.1	35.2
	41.0	38.9	36.7	33.8
POOR	39.5	37.4	35.1	32.3
	37.1	35.4	33.0	30.2
VERY POOR	34.5	32.5	30.9	28.0
	31.6	30.9	28.3	25.1

Females:	VO2 max (ml/kg/min)			
	20-29	30-39	40-49	50-59
SUPERIOR	>53.0	>48.7	>46.8	>42.0
	46.8	43.9	41.0	36.8
EXCELLENT	44.2	41.0	39.5	35.2
	41.0	38.6	36.3	32.3
GOOD	38.1	36.7	33.8	30.9
	36.7	34.6	32.3	29.4
FAIR	35.2	33.8	30.9	28.2
	33.8	32.3	29.5	26.9
POOR	32.3	30.5	28.3	25.5
	30.6	28.7	26.5	24.3
VERY POOR	28.3	26.5	25.1	22.3
	25.9	25.1	23.5	21.1

WORKOUT DESCRIPTIONS

FIT TEST

The WFI (Wellness Fitness Initiative) protocol is a modified Gerkin test used by firefighters to evaluate aerobic fitness capacity as part of pre-employment testing and annual fitness testing. The goal is to meet or exceed 12 minutes and 30 seconds. This assessment is a series of one-minute intervals, alternating between speed and percent grade. The WFI protocol is only available on the T5x.

To enter into this workout on a T5x, use the following guidelines:

- 1) Choose the WFI test by pressing the Fitness Test workout button until WFI is shown in the message window and press **ENTER**.
- 2) Enter age using the **ARROW KEYS** or the **NUMBER KEYPAD** and press **ENTER**
- 3) The message window will display your target heart rate based upon your age and the target heart rate zone of 85%.
- 4) Select gender using the **ARROW KEYS** and press **ENTER**.
- 5) Enter user weight (user weight is used to calculate the caloric expenditure value-providing an accurate weight helps to ensure an accurate caloric expenditure rating for each user) using the **ARROW KEYS** or the **NUMBER KEYPAD** and press **ENTER**.
- 6) The message window will notify the user that the start speed is 3.0 mph (4.8 kph) and 0% incline during the warm-up.
- 7) Press **GO** or **QUICK START** to begin the workout.



The Military Test programs and the Physical Efficiency Battery (PEB) provide workouts of a preset distance. These distances are established by the various branches of the Military with the objective of each test to complete the distance as quickly as possible. At the completion of the test, a time-based score as defined by the respective Military branch will be shown on the console.

To enter into this workout on the T5x, use the following guidelines:

- 1) Choose your desired Military test by pressing the Fitness Test workout button until your desired branch test is shown in the message window and press **ENTER**.
- 2) Enter age using the **ARROW KEYS** or the **NUMBER KEYPAD** and press **ENTER**
- 3) Select gender using the **ARROW KEYS** and press **ENTER**.
- 4) Enter user weight (user weight is used to calculate the caloric expenditure value-providing an accurate weight helps to ensure an accurate caloric expenditure rating for each user) using the **ARROW KEYS** or the **NUMBER KEYPAD** and press **ENTER**.
- 5) Enter the desired start speed using the **ARROW KEYS** or the **NUMBER KEYPAD** and press **ENTER**.
- 6) Press **GO** or **QUICK START** to begin the workout.

To enter into a Military Fitness Test workout on a T7x or a T7xe, follow the onscreen prompts.

USB FEATURES

- Software Updates
- USB Charging
- Record Workout Statistics to USB
- Upload Workout Statistics to www.livestrong.com



SOFTWARE UPDATES

The USB port is used to update the console firmware. Copy the updated software file to the root directory of your USB drive and insert into the USB port with the console at the main screen. The console will beep once to indicate it has recognized the USB stick and beep twice when the firmware upgrade is complete.

USB CHARGING

The USB port on the consoles is capable of powering USB devices. It provides up to 1.0amp of power and meets USB 2.0 regulations. You can not “mount” or “connect” to the console via USB device, only charge.

RECORD WORKOUT STATISTICS TO USB

Your consoles have a USB port on the top-left of the console. Plug in a USB drive before your workout summary screen disappears, within 10 seconds of ending your workout. The console will beep once when it detects a USB drive has been detected. Workout statistics will automatically be saved at the end of your workout while displaying your workout information. The console will beep 2 times and display that your workout statistics have been saved successfully.

Note: The USB drive does not need to be in the entire workout. It must be inserted before the workout summary screen ends or the workout statistics will be erased.

UPLOAD WORKOUT STATISTICS TO WWW.LIVESTRONG.COM

Once you have saved your workout statistics to a USB drive, you need to upload the workout statistics to www.livestrong.com. In order to save and view your workout statistics on www.livestrong.com, follow these instructions:

- 1) You must first create an account on www.livestrong.com.
- 2) Plug your USB drive with saved workout statistics into a PC/MAC. Go to www.livestrong.com/equipment. Select “Browse”. Direct the file browser to your USB location containing the .wrk file from your workout (file name will be: MMDDYY.wrk). Select Save. Now you will be able to keep track and view all of your workouts completed on your equipment through www.livestrong.com.

*Note: www.livestrong.com workout tracking is not available in all regions.

AVAILABLE ON ALL T7X AND T7XE CONSOLES

Nike + iPod

READY

Connect your Nike Plus-compatible device to the built-in Made for iPod connector on Nike + iPod compatible fitness equipment.

SET

Full console controls make it easy to exercise to your favorite workout playlist.

GO

Start walking or running. Your pace, distance, time, and calories burned are recorded as you go. It's all automatically saved on your iPod or iPhone.

SYNC

When you're done with your workout, connect your iPod or iPhone to your computer. iTunes syncs your workout data to nikeplus.com. Every workout and every run is there, ready for you to review.



"Made for iPod" means that an electronic accessory has been designed to connect specifically to iPod and has been certified by the developer to meet Apple performance standards. Apple is not responsible for the operation of this device or its compliance with safety and regulatory standards. iPod is a trademark of Apple Inc., registered in the U.S. and other countries.

NIKE + OPERATION

REQUIREMENTS

Nike Plus – compatible iPod or iPhone (See www.apple.com/nikeplus for more information).

Before syncing your Apple device to your computer, you must first create a free Nike Plus account at www.nikerunning.com and download the latest iTunes software (www.apple.com/itunes).

GETTING STARTED

- 1) Before connecting your Apple device, you must first turn on Nike Plus on the device.
- 2) Dock your Apple device and wait for authentication to complete. This may take up to 10 seconds. After authentication is complete, your iPod-specific console controls will be active (see next page).
- 3) If your iPod or iPhone is Nike Plus compatible, your workout will begin recording automatically to your Nike Plus compatible device.
- 4) When your workout is complete, your workout data will be recorded to your Nike Plus compatible device.
- 5) Remove your Nike Plus compatible device and sync with iTunes.
- 6) Log into your Nike Running account to review and track your workouts.





PRODUCT SPECIFICATIONS





MODEL NAME	T-5x/7x	
TREADMILL TYPE	T7x [®] TREADMILL	T7x TREADMILL
FRAME PART#	T-5x/7x-F	
CONSOLE PART #	T7xe-03-C	T-7x-03-C
FEATURES		
DECK TYPE	ULTIMATE™ HARD-WAX REVERSIBLE 1" DECK	ULTIMATE™ HARD-WAX REVERSIBLE 1" DECK
BELT TYPE	HABISAT - 2-PLY COMMERCIAL GRADE	HABISAT - 2-PLY COMMERCIAL GRADE
RUNNING AREA	60" X 22"	60" X 22"
DECK STEP HEIGHT	9.5"	9.5"
CUSHION SYSTEM	ULTIMATE DECK™ CUSHIONING SYSTEM	ULTIMATE DECK™ CUSHIONING SYSTEM
INCLINE RANGE	0-15% (1,300 LB THRUST INCLINE MOTOR)	0-15% (1,300 LB THRUST INCLINE MOTOR)
SPEED RANGE	0.5 - 15* MPH	0.5 - 15* MPH
CONTACT & TELEMETRIC HR SENSORS	YES	YES
DRIVE SYSTEM		
MOTOR	MATRIX 5.0 HP AC DYNAMIC RESPONSE DRIVE SYSTEM™	MATRIX 5.0 HP AC DYNAMIC RESPONSE DRIVE SYSTEM™
MOTOR CONTROLLER	COMMERCIAL TREADMILL AC DRIVE	COMMERCIAL TREADMILL AC DRIVE
CONSOLE		
DISPLAY TYPE	15" TOUCH SCREEN LCD	7" LCD
DISPLAY FEEDBACK	TIME, DISTANCE (KILOMETERS OR MILES), CALORIES, CALORIES PER HOUR, SPEED, INCLINE, PACE, HEART RATE, METS, WATTS, DYNAMIC PROFILE DISPLAY, STATIC PROFILE DISPLAY	TIME, DISTANCE (KILOMETERS OR MILES), CALORIES, CALORIES PER HOUR, SPEED, INCLINE, PACE, HEART RATE, METS, WATTS, PROFILE
USER DEFINED MULTI-LANGUAGE DISPLAY	YES - ENGLISH, GERMAN, FRENCH, ITALIAN, SPANISH, DUTCH, PORTUGUESE, CHINESE, JAPANESE, KOREAN, SWEDISH, FINNISH, RUSSIAN, ARABIC	YES - ENGLISH, GERMAN, FRENCH, ITALIAN, SPANISH, DUTCH, PORTUGUESE, CHINESE, JAPANESE, KOREAN, SWEDISH, FINNISH, RUSSIAN, ARABIC
WORKOUTS	MANUAL, ROLLING HILLS, FAT BURN, 5K, TARGET HR, GERKIN PROTOCOL, ARMY PFT, NAVY PRT, MARINE PFT, AIR FORCE PRT, PHYSICAL EFFICIENCY BATTERY (PEB)	MANUAL, ROLLING HILLS, FAT BURN, 5K, TARGET HR, GERKIN PROTOCOL, ARMY PFT, NAVY PRT, MARINE PFT, AIR FORCE PRT, PHYSICAL EFFICIENCY BATTERY (PEB)
CSAFE, FITLINXX READY	YES	YES
NETPULSE READY	NO	YES
ON-THE-FLY PROGRAM CHANGE	YES	YES
FIT TOUCH TECHNOLOGY™	YES	NO
INTEGRATED VISTA CLEAR™ DIGITAL READY TELEVISION	YES-15" SCREEN SIZE	YES-7" SCREEN SIZE
VIRTUAL ACTIVE™ COMPATIBLE	YES	YES
FITCONNEXION™ READY	NO	YES
WIRELESS DATA TRANSMITTER	YES	YES
IPOD® COMPATIBLE	YES	YES
NIKE + IPOD COMPATIBLE	YES	YES
USB WORKOUT TRACKING	YES - VIA LIVESTRONG.COM	YES - VIA LIVESTRONG.COM
PERSONAL FAN	YES	YES
CROSSBAR CONTROLS	QUICK START, STOP, COOL DOWN, SPEED AND INCLINE CONTROL	QUICK START, STOP, COOL DOWN, SPEED AND INCLINE CONTROL
TECH SPECS		
OVERALL DIMENSIONS L X W X H	84.6" X 33.7" X 58" 214.9CM X 85.6CM X 147.3CM	84.6" X 33.7" X 58" 214.9CM X 85.6CM X 147.3CM
MAXIMUM USER WEIGHT	400 LBS/182 KG	400 LBS/182 KG
WEIGHT	399 LBS/181 KG	397 LBS/180 KG
SHIPPING WEIGHT	440 LBS/200 KG	437 LBS/199 KG
ELECTRICAL RECEPTACLE & PLUG	NEMA 5-20R 120V	NEMA 5-20R 120V
ELECTRICAL REQUIREMENTS	20 AMPS-DEDICATED CIRCUIT REQUIRED-NON-LOOPED GROUNDED	20 AMPS-DEDICATED CIRCUIT REQUIRED-NON-LOOPED GROUNDED

*15 MPH RATING GOOD UP TO 350 LBS USER



MODEL NAME	T-5x/7x
TREADMILL TYPE	T5x TREADMILL
FRAME PART#	T-5x/7x-F
CONSOLE PART #	T-5X-05-C
FEATURES	
DECK TYPE	ULTIMATE™ HARD-WAX REVERSIBLE 1" DECK
BELT TYPE	HABASIT - 2-PLY COMMERCIAL GRADE
RUNNING AREA	60" X 22"
DECK STEP HEIGHT	9.5"
CUSHION SYSTEM	ULTIMATE DECK™ CUSHIONING SYSTEM
INCLINE RANGE	0-15% (1,300 LB THRUST INCLINE MOTOR)
SPEED RANGE	0.5 - 12 MPH
CONTACT & TELEMETRIC HR SENSORS	YES
DRIVE SYSTEM	
MOTOR	MATRIX 5.0 HP AC DYNAMIC RESPONSE DRIVE SYSTEM™
MOTOR CONTROLLER	COMMERCIAL TREADMILL AC DRIVE
CONSOLE	
DISPLAY TYPE	DOT-MATRIX LED
DISPLAY FEEDBACK	TIME, DISTANCE, CALORIES, SPEED, INCLINE, PACE, HEART RATE, METS, WATTS
USER DEFINED MULTI-LANGUAGE DISPLAY	NO - ACCESSIBLE THROUGH MANAGER MENU; ENGLISH, GERMAN, FRENCH, ITALIAN, SPANISH, DUTCH, PORTUGUESE, JAPANESE, KOREAN, SWEDISH, FINNISH, RUSSIAN
WORKOUTS	MANUAL, ROLLING HILLS, FAT BURN, 5K, TARGET HR, GERKIN PROTOCOL, ARMY PFT, NAVY PRT, MARINE PFT, AIR FORCE PRT, PHYSICAL EFFICIENCY BATTERY (PEB), WFI PROTORCOL
CSAFE, FITLINX READY	YES
NETPULSE READY	YES
ON-THE-FLY PROGRAM CHANGE	YES
FIT TOUCH TECHNOLOGY™	NO
INTEGRATED VISTA CLEAR™ DIGITAL READY TELEVISION	NO
VIRTUAL ACTIVE™ COMPATIBLE	NO
FITCONNECTION™ READY	YES
WIRELESS DATA TRANSMITTER	YES
IPOD® COMPATIBLE	YES - CHARGING ONLY
NIKE + IPOD COMPATIBLE	NO
USB WORKOUT TRACKING	YES - VIA LIVESTRONG.COM
PERSONAL FAN	YES
CROSSBAR CONTROLS	QUICK START, STOP, COOL DOWN
MANAGER MODE	RESETTABLE DEFAULTS WITH ACCUMULATED TIME AND DISTANCE
TECH SPECS	
OVERALL DIMENSIONS L X W X H	84.6" X 33.7" X 58" 214.9CM X 85.6CM X 147.3CM
MAXIMUM USER WEIGHT	400 LBS/182 KG
WEIGHT	394 LBS/179 KG
SHIPPING WEIGHT	433 LBS/197 KG
ELECTRICAL RECEPTACLE & PLUG	NEMA 5-20R 120V
ELECTRICAL REQUIREMENTS	20 AMPS-DEDICATED CIRCUIT REQUIRED-NON-LOOPED GROUNDED

*15 MPH RATING GOOD UP TO 350 LBS USER

**LIGHT COMMERCIAL WARRANTY - 6 HOURS OF USE OR LESS DAILY



1-866-693-4863
www.matrixfitness.com

Matrix Fitness
1600 Landmark Drive,
Cottage Grove, WI 53527