

**MATRIX**  
Strong • Smart • Beautiful

**C7xi**  
**C7xe**  
**C5x**  
**C3x**

CLIMBMILL OWNER'S MANUAL

3	IMPORTANT PRECAUTIONS
9	CLIMBMILL ASSEMBLY
15	LOCATION & SETUP
17	TROUBLESHOOTING & MAINTENANCE
21	CLIMBMILL OPERATION
37	CLIMBMILL WORKOUTS
45	PRODUCT SPECIFICATIONS

# IMPORTANT PRECAUTIONS



## SAVE THESE INSTRUCTIONS

When using a Climbmill, basic precautions should always be followed, including the following: Read all instructions before using this product. It is the responsibility of the owner to ensure that all users of this product are adequately informed of all warnings and precautions. If you have any questions after reading this guide, contact Customer Tech Support at the number listed on the back panel of the OWNER'S MANUAL.

This product is intended for commercial use. To ensure your safety and protect the equipment, read all instructions before operating.



## **DANGER**

### **TO REDUCE THE RISK OF ELECTRICAL SHOCK:**

Always unplug the unit from the electrical outlet immediately after using, before cleaning, performing maintenance and putting on or taking off parts.

## **WARNING**

### **TO REDUCE THE RISK OF BURNS, FIRE, ELECTRICAL SHOCK OR INJURY TO PERSONS:**

- An appliance should never be left unattended when plugged in. Unplug the entertainment equipment from outlet when not in use and before putting on or taking off parts.
- This product must be used for its intended purpose described in this Owner's Guide.
- To prevent electrical shock, never drop or insert any object into any opening.
- Do not remove side covers. Service should only be done by an authorized service technician.
- Never operate the machine with the air opening blocked. Keep the air opening clean, free, of lint, hair and the like.
- Never operate the product if it has a damaged cord or plug, if it is not working properly, if it has been damaged, or immersed in water. Return the unit to a service center for examination and repair.
- Do not carry this unit by entertainment equipment power cord or use cord as handle.
- Keep any of the entertainment equipment power cords away from heated surfaces
- Keep hands and loose clothing away from moving parts.
- Close supervision is necessary when the machine is used by or near children or disabled persons.
- Do not use outdoors.
- Do not operate where aerosol (spray) products are being used or where oxygen is being administered.
- Connect this machine to a properly grounded outlet only.
- To disconnect, turn all entertainment controls to the off position, then remove plug from outlet.
- Keep power cord away from heated surfaces. Do not carry this unit by its supply cord or use the cord as a handle.
- Do not use other attachments that are not recommended by the manufacturer. Attachments may cause injury.

## **WARNING**

- Use the unit only as described in the unit guide and owner's manual.
- Incorrect or excessive exercise may cause injury. If you experience any kind of pain, including but not limited to chest pains, nausea, dizziness, or shortness of breath, stop exercising immediately and consult your physician before continuing.
- Do not wear clothes that might catch on any part of the unit.
- Always wear athletic shoes while using this equipment.
- Do not jump on the unit.
- At no time should more than one person be on unit while in operation.
- This unit should not be used by persons weighing more than specified in the OWNER'S MANUAL SPECIFICATIONS SECTION. Failure to comply will void the warranty.
- Disconnect all power before servicing or moving the equipment. To clean, wipe surfaces down with soap and slightly damp cloth only; never use solvents. (See MAINTENANCE)
- The unit should never be left unattended when plugged in. Unplug from outlet when not in use, and before putting on or taking off parts.
- Do not operate under blanket or pillow. Excessive heating can occur and cause fire, electric shock, or injury to persons.
- At NO time should pets or children under the age of 14 be closer to the unit than 10 feet.
- At NO time should children under the age of 14 use the unit.
- Children over the age of 14 or disabled persons should not use the unit without adult supervision.
- Never operate the unit if it has a damaged cord or plug, if it is not working properly, if it has been dropped or damaged, or immersed in water. Return the unit to a service center for examination and repair.
- To disconnect, turn all controls to the off position, then remove plug from outlet.
- Do not remove the console covers unless instructed by Customer Tech Support. Service should only be done by an authorized service technician.
- This unit is not equipped with a free wheel. Step speed should be reduced in a controlled manner.
- Heart rate monitoring systems may be inaccurate.
- Over exercising may result in serious injury or death.
- If you feel faint, stop exercising immediately.





## **CAUTION**

**CONSULT A PHYSICIAN BEFORE USING THIS EQUIPMENT. READ OWNER'S MANUAL BEFORE USE.**

It is essential that your unit is used only indoors, in a climate controlled room. If your unit has been exposed to colder temperatures or high moisture climates, it is strongly recommended that the unit is warmed up to room temperature before first time use. Failure to do so may cause premature electronic failure.

## **DEDICATED CIRCUIT AND ELECTRICAL INFO**

A “Dedicated Circuit” means that each outlet you plug into should not have anything else running on that same circuit. The easiest way to verify this is to locate the main circuit breaker box, and turn off the breaker(s) one at a time. Once a breaker has been turned off, the only thing that should not have power to it are the units in question. No lamps, vending machines, fans, sound systems, or any other item should lose power when you perform this test.

Non-looped (isolated) neutral/grounding means that each circuit must have an individual neutral/ground connection coming from it, and terminating at an approved earth ground. You cannot “jumper” a single neutral/ground from one circuit to the next.

## **ELECTRICAL REQUIREMENTS**

For your safety and to ensure good unit performance, the ground on this circuit must be non-looped (isolated). Please refer to NEC article 210-21 and 210-23. Any alterations to the standard power cord provided could void all warranties of this product.

For units with an integrated TV (7xe and 7xi), the TV power requirements are included in the unit. An RG6 coaxial cable with 'F Type' compression fittings on each end will need to be connected to the cardio unit and the video source. Additional power requirements are not needed for the add-on digital TV. For units with an add-on PCTV (5x), the TV power requirements are separate.

## 110 V UNITS

All Matrix 3x, 5x, 7xe and 7xi 110 V Climbmills require the use of a 100-125 V, 60 Hz and a 15 A “Dedicated Circuit”, with a non-looped (isolated) neutral/ground for power. This outlet should be a NEMA 5-15R and have the same configuration as the plug. No adapter should be used with this product. These Climbmills can be daisy-chained together with up to 4 units per 15 A dedicated circuit. Matrix daisy-chain cord adapters are sold separately.

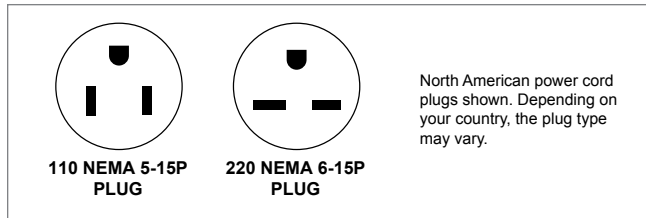

## 220 V UNITS

All Matrix 3x, 5x, 7xe and 7xi 220 V Climbmills require the use of a 216-250 V, 50 Hz and a 15 A “Dedicated Circuit”, with a non-looped (isolated) neutral/ground for power. This outlet should be a NEMA 6-15R and have the same configuration as the plug. No adapter should be used with this product. These Climbmills can be daisy-chained together with up to 4 units per dedicated 15 A circuit. Matrix daisy-chain cord adapters are sold separately.

## GROUNDING INSTRUCTIONS

The unit must be grounded. If it should malfunction or breakdown, grounding provides a path of least resistance for electric current to reduce the risk of electric shock. The unit is equipped with a cord having an equipment-grounding conductor and a grounding plug. The plug must be plugged into an appropriate outlet that is properly installed and grounded in accordance with all local codes and ordinances. If the user does not follow these grounding instructions, the user could void the Matrix limited warranty.

## ADDITIONAL ELECTRICAL INFO

In addition to the dedicated circuit requirement, the proper gauge wire must be used from the circuit breaker box, to each outlet that will have the maximum number of units running off of it. If the distance from the circuit breaker box to each outlet, is 100 ft (30.5 m) or less, then 12 gauge wire should be used. For distances greater than 100 ft (30.5 m) from the circuit breaker box to the outlet, a 10 gauge wire should be used.

## ENERGY SAVING / LOW-POWER MODE

All units are configured with the ability to enter into an energy saving / low-power mode when the unit has not been in use for a specified period of time. Additional time may be required to fully reactivate this unit once it has entered the low-power mode. This energy saving feature may be enabled or disabled from within the ‘Manager Mode’ or ‘Engineering Mode.’





## ADD-ON PCTV (3X & 5X)

A 15 A or 20 A “Dedicated Circuit” with a non-looped (isolated) neutral/ground is required. Each PCTV requires at least 1.2 A of current (either from 110 V or 220 V). No more than 12 PCTVs should be used for each 15 A circuit and no more than 16 PCTVs should be used for each 20 A circuit. The power outlet should have the same configuration as the plug. No adapter should be used with this product. An RG6 coaxial cable with ‘F Type’ compression fittings will need to be connected between the video source and each add-on PCTV unit.

## ADD-ON DIGITAL TV (3X & 5X)

Additional power requirements are not needed for the add-on digital TV. An RG6 coaxial cable with ‘F Type’ compression fittings will need to be connected between the video source and each add-on digital TV unit.



## DANGER

Improper connection of the equipment-grounding conductor can result in a risk of electric shock. Check with a qualified electrician or serviceman if you are in doubt as to whether the product is properly grounded. Do not modify the plug provided with the product. If it will not fit the outlet, have a proper outlet installed by a qualified electrician.



## WARNING

Connect this exercise product to a properly grounded outlet only.

Never operate product with a damaged cord or plug even if it is working properly. Never operate any product if it appears damaged, or has been immersed in water. Contact Customer Tech Support for replacement or repair.



## WARNING:

Failure to follow these specifications can cause damage to your product and can void the warranty.

- All video and power outlets must be functional the day of delivery / assembly of the product. The client is responsible for any additional installation charges associated with return visits.
- Electrical supply may fluctuate in your area. To ensure stable performance of the product, use the proper gauge wire.



# CLIMBMILL ASSEMBLY



## **⚠ WARNING**

There are several areas during the assembly process that special attention must be paid. It is very important to follow the assembly instructions correctly and to make sure all parts are firmly tightened. If the assembly instructions are not followed correctly, the unit could have parts that are not tightened and will seem loose and may cause irritating noises. To prevent damage to the unit, the assembly instructions must be reviewed and corrective actions should be taken.

Before proceeding, find the unit's frame serial number located as shown in the illustration and enter it in the space provided below. The console serial number is located on a barcode sticker on the console, near the connection between the console and the mast.

ENTER YOUR SERIAL NUMBERS AND MODEL NAME IN THE BOXES BELOW:

FRAME SERIAL NUMBER:

CONSOLE SERIAL NUMBER:

MODEL NAME:

<b>MATRIX</b>	<input type="text"/>
---------------	----------------------

FRAME SERIAL NUMBER LOCATION

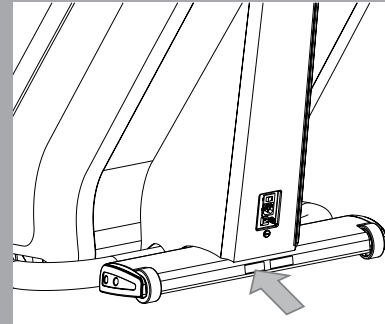

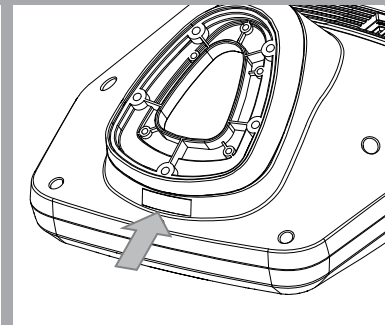

CONSOLE SERIAL NUMBER LOCATION



» Use the information above for initial setup and when calling for service.

# INCLUDED FASTENERS

Qty:	Sketch:	Part Name:	Bag:
4		<b>SOCKET HEAD BOLT</b> (M8x25L)	Black
20		<b>SOCKET HEAD BOLT</b> (M8x20L)	Blue
2		<b>SOCKET HEAD BOLT</b> (M8x35L)	Green
3		<b>SOCKET HEAD BOLT</b> (M8x16L)	Green
4		<b>SOCKET HEAD BOLT</b> (M8x16L)	Blue
4		<b>ARC WASHER</b>	Blue
8		<b>FLAT WASHER</b>	Blue
5		<b>FLAT WASHER</b>	Green

# BEFORE YOU BEGIN

Prior to assembling the unit, unpack all of the contents of the box and make sure that all necessary components are present. Review the contents of the hardware package for completeness.

Contact Matrix Customer Service at 1(866) 693-4863 to report any missing items.

Please make sure that the power plug is not plugged into the wall outlet while completing the following procedure.

To ensure correct assembly of the unit, carefully read and follow all assembly steps.

# REQUIRED TOOLS



6mm ALLEN WRENCH



5mm ALLEN WRENCH



# ASSEMBLY STEP 1

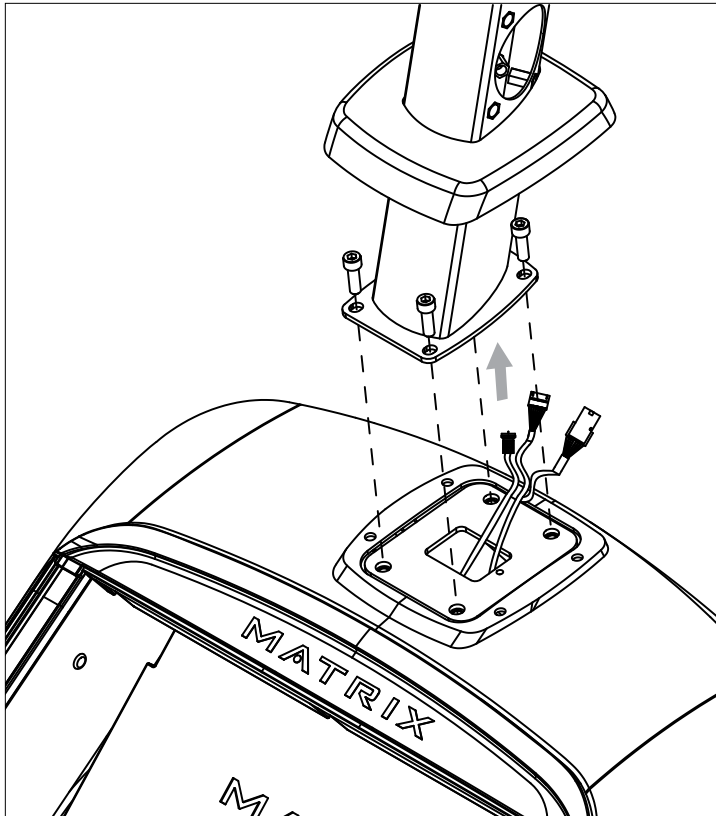

## BLACK HARDWARE BAG CONTENTS :





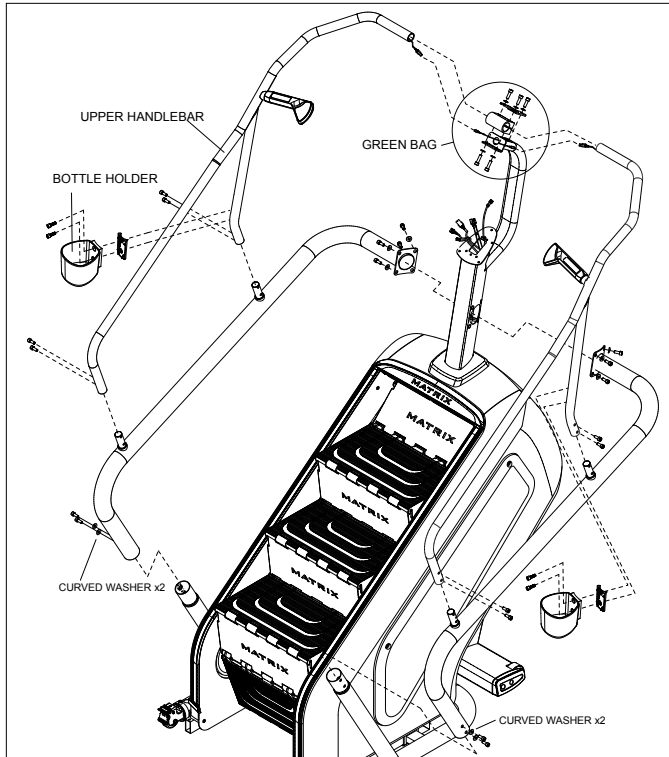

 SOCKET HEAD BOLT(M8x25L)      4      BLACK

- A Open **BLACK HARDWARE BAG**
- B Carefully route the wires up console mast.
- C Attach the console mast to the frame using the provided bolts. Securely tightly, being careful not to pinch any wires.

# ASSEMBLY STEP 2



## BLUE & GREEN HARDWARE BAG CONTENTS

	SOCKET HEAD BOLT(M8x20L)	20	BLUE
	SOCKET HEAD BOLT(M8x16L)	3	GREEN
	SOCKET HEAD BOLT(M8x35L)	2	GREEN
	CURVED WASHER	4	BLUE
	FLAT WASHER	8	BLUE
	FLAT WASHER	5	GREEN
	SOCKET HEAD BOLT(M8x16L)	4	BLUE

- A Open **BLUE HARDWARE BAG**
- B Attach Lower Handlebar using provided bolts. Tighten securely at base and mast.
- C Attach Upper Handlebar using provided bolts. Carefully route and connect all wires to the console mast. Tighten securely.
- D Attach Bottle Holder using provided bolts.
- E Repeat on the other side.

## ASSEMBLY STEP 3

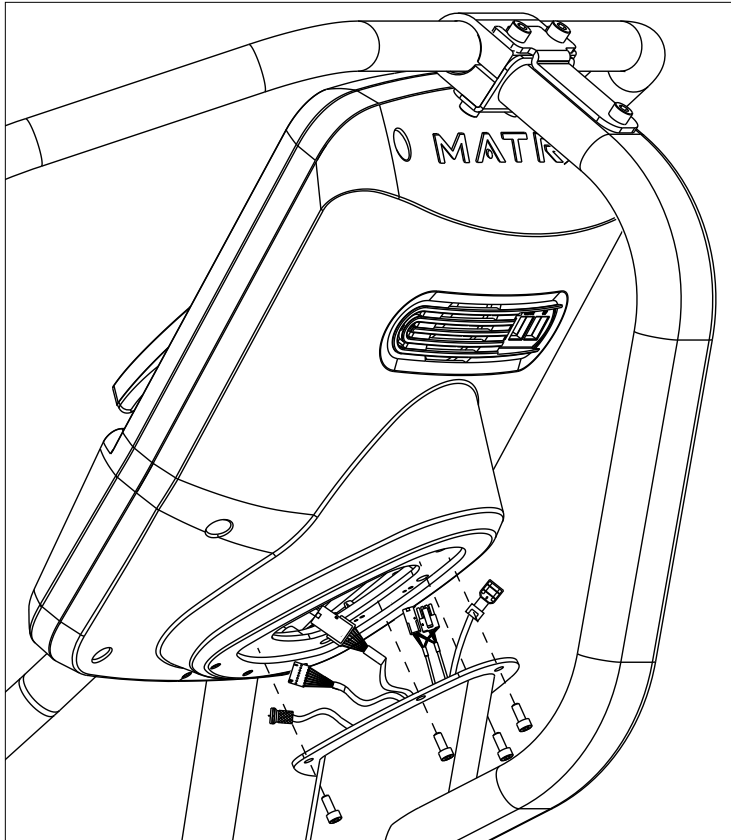

### CONTENTS ARE PRE-ATTACHED:

 SOCKET HEAD BOLT(M5x12L) 5

- A Remove the five pre-attached console screws from back of console.
- B Carefully connect all wires coming from the mast to the inside of the console.

Note: Depending on the console, not all cables coming from the mast will need to be connected.

- C Attach console to console mast using provided bolts. Secure tightly, being careful not to pinch any wires.

For C3x, skip page 14 and continue on page 15.



## C5x, C7xe, C7xi ASSEMBLY STEP 4

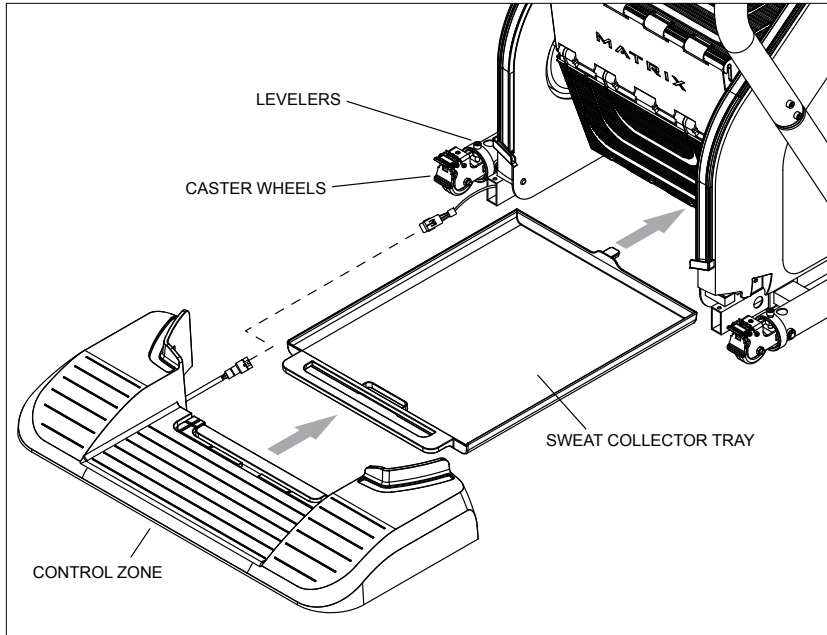

- A Connect the wires from the frame to the Base Step.
- B Lift the Control Zone over the caster wheels. Push down firmly on both sides until it seats firmly.
- C Slide the Sweat Collector Tray under the Climbmill, latching the handle to the base.

**ASSEMBLY COMPLETE!**

C7XE SHOWN

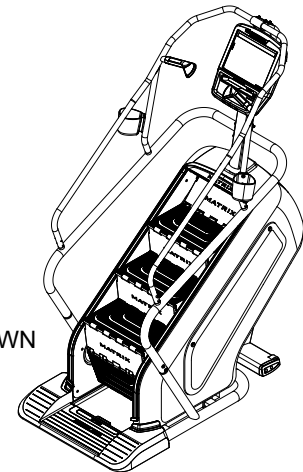

## C3x ASSEMBLY STEP 4

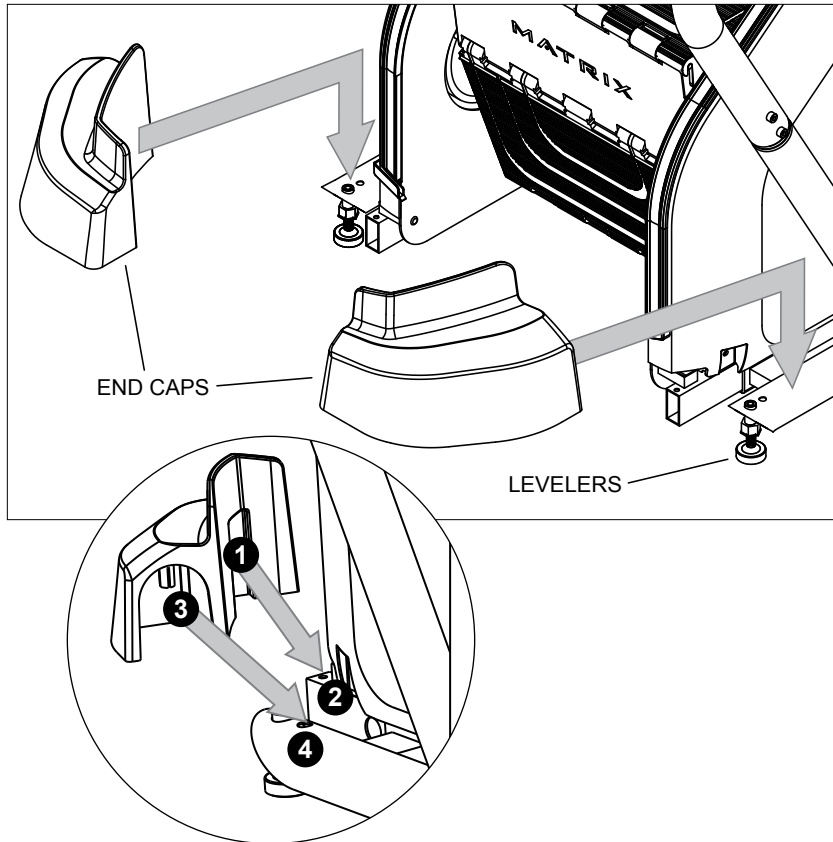

- A To attach end caps, slide (1) over (2) and then slide (3) into (4).

**C3X ASSEMBLY COMPLETE!**

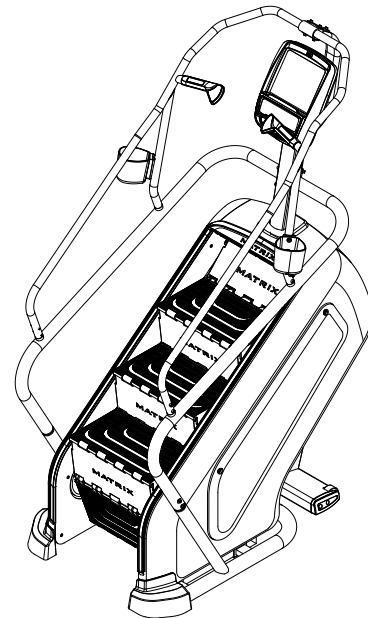





# LOCATION & SETUP



## LOCATION OF THE UNIT

Place the unit on a level and stable surface away from direct sunlight. The intense UV light can cause discoloration on the plastics. Locate your unit in an area with cool temperatures and low humidity. Please leave a clear zone behind the unit that is at least 24" (600 mm). This zone must be clear of any obstruction and provide the user a clear exit path from the machine. Do not place the unit in any area that will block any vent or air openings. The unit should not be located in a garage, covered patio, near water or outdoors.

## LEVELING THE UNIT

Locate a level, stable surface to position the equipment. The equipment has levelers located below the bottom step. To access the levelers, remove the end caps (C3X) or CONTROL ZONE (C5X, C7XE and C7XI). CAUTION: There is an electrical plug located under the CONTROL ZONE and will need to be unplugged before the cover can be completely removed. Use an allen wrench to level the unit. Once stable, replace parts as they were removed.

## HEIGHT REQUIREMENTS

The Climbmill adds 30 - 38" (76 - 96.5cm) to a users height. For example, a 6' (183cm) tall user will be 8'6" - 9' 2" (259.5 - 279.5cm) off the floor.

## BEFORE USING THE UNIT PERFORM INITIAL SETUP.



24" 600 mm

## WARNING

Our equipment is heavy, use care and additional help if necessary when moving. Failure to follow these instructions could result in injury.

## WARNING

Never operate product if it has a damaged cord or plug, if it is not working properly, if it has been damaged, or immersed in water. Contact Customer Tech Support for examination and repair.

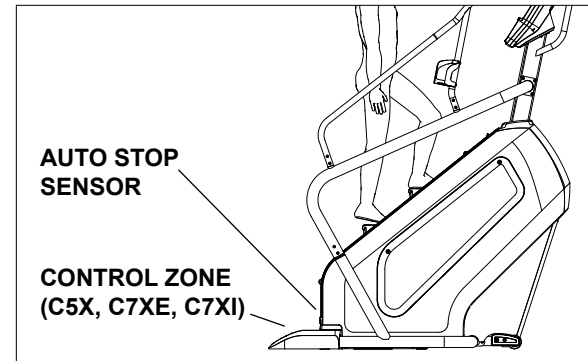

# TROUBLESHOOTING & MAINTENANCE



## RECOMMENDED CLEANING TIPS

Preventative maintenance and daily cleaning will prolong the life and look of your equipment.

- A Use a soft, clean cotton cloth. DO NOT use paper towels to clean surfaces on the climbmill. Paper towels are abrasive and can damage surfaces.
- B Use a mild soap and damp cloth. DO NOT use ammonia based cleaner or alcohol. This will cause discoloring of the aluminum and plastics it comes into contact with.
- C Do not pour water or cleaning solutions on any surface. This could cause electrocution.
- D Wipe the console, heart rate grip, handles, foot pads and handlebars after each use.

For cleaning 7xe and 7xi displays, use distilled water in an atomizer spray bottle. Spray distilled water onto soft, clean, dry cloth and wipe display until clean and dry. For very dirty displays, adding vinegar is recommended.

**CAUTION:** Be sure to have proper assistance to install and move the unit in order to avoid injury or damage.

## CHECK FOR DAMAGED PARTS

**DO NOT** use any equipment that is damaged or has worn or broken parts. Use only replacement parts supplied by Matrix Fitness.

### **MAINTAIN LABELS AND NAMEPLATES.**

Do not remove labels for any reason. They contain important information. If unreadable or missing, contact Matrix Fitness Systems for a replacement. 1-866-693-4863, [www.matrixfitness.com](http://www.matrixfitness.com)

### **MAINTAIN ALL EQUIPMENT**

Preventative maintenance is the key to smooth operating equipment, as well as keeping the user's liability to a minimum. Maintain a clean area around the equipment, free from dust and dirt. Equipment needs to be inspected at regular intervals. Defective components must be replaced immediately. Improperly working equipment must be kept out of use until it is repaired. Ensure that any person(s) making adjustments or performing maintenance or repair of any kind is qualified to do so. Matrix Fitness Systems will provide service and maintenance training at our corporate facility upon request or in the field if proper arrangements are made.



# CARE AND MAINTENANCE

## HOW DO I CLEAN MY MACHINE?

Clean with soap and water cleaners only. Never use solvents on plastic parts. Cleanliness of your Climbmill and its operating environment will keep maintenance problems and service calls to a minimum. For this reason, Customer Tech Support recommends that the following preventive maintenance schedule be followed.

### DAILY

- Unplug the unit. Clean entire machine using water and a mild soap or other Matrix approved solution (cleaning agents should be alcohol and ammonia free).

### MONTHLY (C3x only)

Unplug the Climbmill and remove the access panel. Clean chain of old grease and re-apply a lithium-based grease to each chain link.

### QUARTERLY

- Check step motion and stability to ensure the Climbmill does not rock or wobble.
- Check all connecting joint areas for tightness of bolt assemblies.
- Ensure that there is little, or no free play at all joint assemblies once bolts have been tightened. Installation of washer kits may be required if free play does not come out from tightening bolts.
- Unplug the Climbmill and remove the access panel. Clean sprockets of old grease and re-apply a lithium-based grease to sprocket teeth.
- Unplug the Climbmill and clean the AUTO STOP SENSORS (located under the bottom step) and IR sensor windows on Control Zone with a cotton swab and rubbing alcohol.
- For 7xe consoles, enter service mode and select 'test'. Select 'touch calibration' and then select 'start'. Follow the on-screen prompts and touch the screen where indicated.

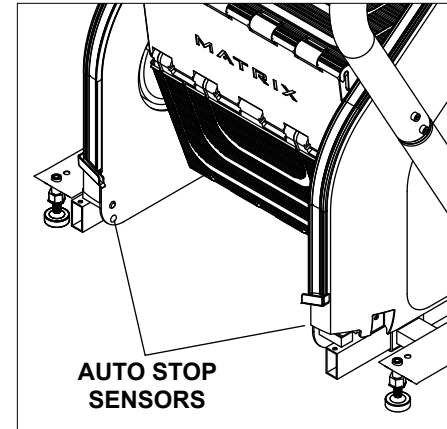

## CONSOLE RESPONSIVENESS ISSUES (CONSOLE REBOOT):

### FOR 7XE CONSOLES

- Press and HOLD the Channel Up and Channel Down Button until you hear a Beep. Your console will reset.



# MATRIX ASSET MANAGEMENT

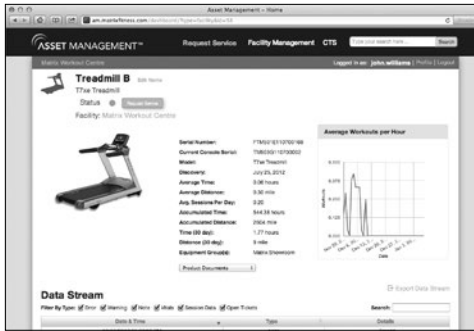
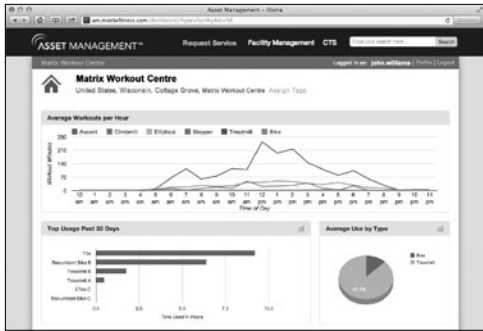

The Asset Management system is a feature available on all 5x, 7x, 7xe, and 7xi machines designed to allow remote monitoring of cardio equipment.

This web-based feature provides users with the ability to log in from anywhere with internet connectivity and check on the status of all their equipment. The site provides information including serial numbers, time/distance totals, software versions, and a history of any error codes that the unit has shown.

The system will send email notifications for any error messages that occur on the equipment, notifying both Matrix Fitness customer support and the facility.

To provide the best experience possible, Matrix Fitness Asset Management also allows a user to create a service request ticket in the event that there is a problem with a piece of equipment.

Additionally, service guides, parts lists, and unit drawings for each machine are available through the Asset Management site.

Asset Management site: [am.matrixfitness.com](http://am.matrixfitness.com)

# CLIMBMILL OPERATION



## MOUNTING THE CLIMBMILL

Stand directly behind the Climbmill. Grasp either the upper or lower handle bars and step onto the Climbmill until you are within comfortable reach of the console and remote handlebar controls.

The CONTROL ZONE will bring the step surfaces to a complete stop upon detecting an object. The AUTO STOP SENSOR will bring the step surfaces to a complete stop upon detecting an object under the bottom step.

## PROPER USAGE

To determine proper workout position, stand on the steps within comfortable reach of the console. Maintain a constant distance from the console and remote handlebar controls. Keep your knees slightly bent at all times.

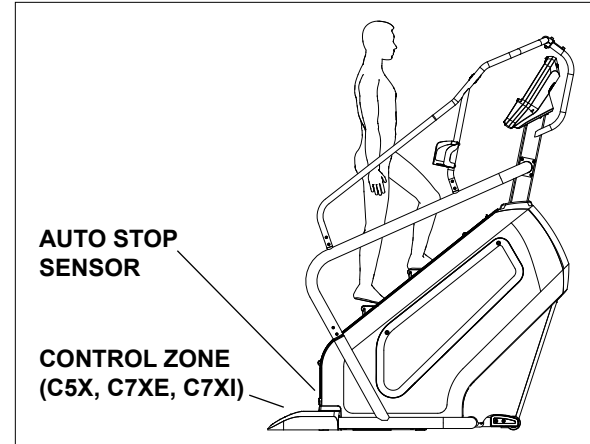

## USING THE HEART RATE FUNCTION

The heart rate function on this product is not a medical device. While heart rate grips can provide a relative estimation of your actual heart rate, they should not be relied on when accurate readings are necessary. Some people, including those in a cardiac rehab program, may benefit from using an alternate heart rate monitoring system like a chest or wrist strap. Various factors, including movement of the user, may affect the accuracy of your heart rate reading. The heart rate reading is intended only as an exercise aid in determining heart rate trends in general. Please consult your physician.

## PULSE GRIPS

Place the palm of your hands directly on the grip pulse handlebars. Both hands must grip the bars for your heart rate to register. It takes 5 consecutive heart beats (15-20 seconds) for your heart rate to register. When gripping the pulse handlebars, do not grip tightly. Holding the grips tightly may elevate your blood pressure. Keep a loose, cupping hold. You may experience an erratic readout if consistently holding the grip pulse handlebars. Make sure to clean the pulse sensors to ensure proper contact can be maintained.





## WIRELESS HEART RATE RECEIVER

When used in conjunction with a **wireless chest transmitter**, your heart rate can be transmitted wirelessly to the unit and displayed on the console.

Prior to wearing the wireless chest transmitter on your chest, moisten the two rubber electrodes with water. Center the chest strap just below the breast or pectoral muscles, directly over your sternum, with the logo facing out. NOTE: The chest strap must be tight and properly placed to receive an accurate and consistent readout. If the chest strap is too loose, or positioned improperly, you may receive an erratic or inconsistent heart rate readout.

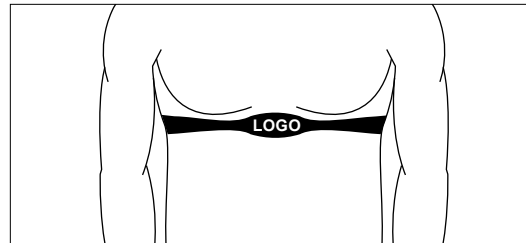
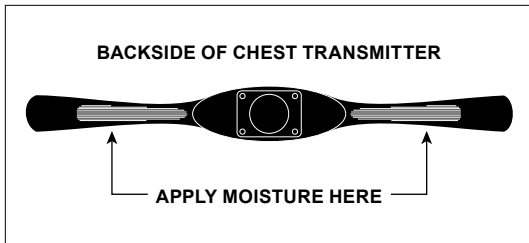

## WARNING!

Heart rate monitoring systems may be inaccurate. Over exercising may result in serious injury or death. If you feel faint, stop exercising immediately.





## 3X CONSOLE DESCRIPTION

The Matrix machine is inspected before it is packaged. It is shipped in two pieces: the base and the console. Carefully unpack the unit and dispose of the box material. Note: There is a thin protective sheet of clear plastic on the overlay of the console that should be removed before use.



- A) **WORKOUT KEYS:** Simple program view and selection buttons.
- B) **GO:** One Touch Start.
- C) **ENTER:** To confirm each program setting.
- D) **UP/DOWN TIME:** Use to adjust workout time.
- E) **UP/DOWN LEVEL:** Use to adjust level selection.
- F) **STOP:** Ends workout and shows workout summary data.
- G) **COOL DOWN:** Puts the console into Cool Down mode.
- H) **TOGGLE DISPLAY:** Cycles between 3 or 4 rows of workout information displayed in LED window. The console will automatically cycle between the workout information if the Toggle Display button is pushed and held down for 3 seconds.

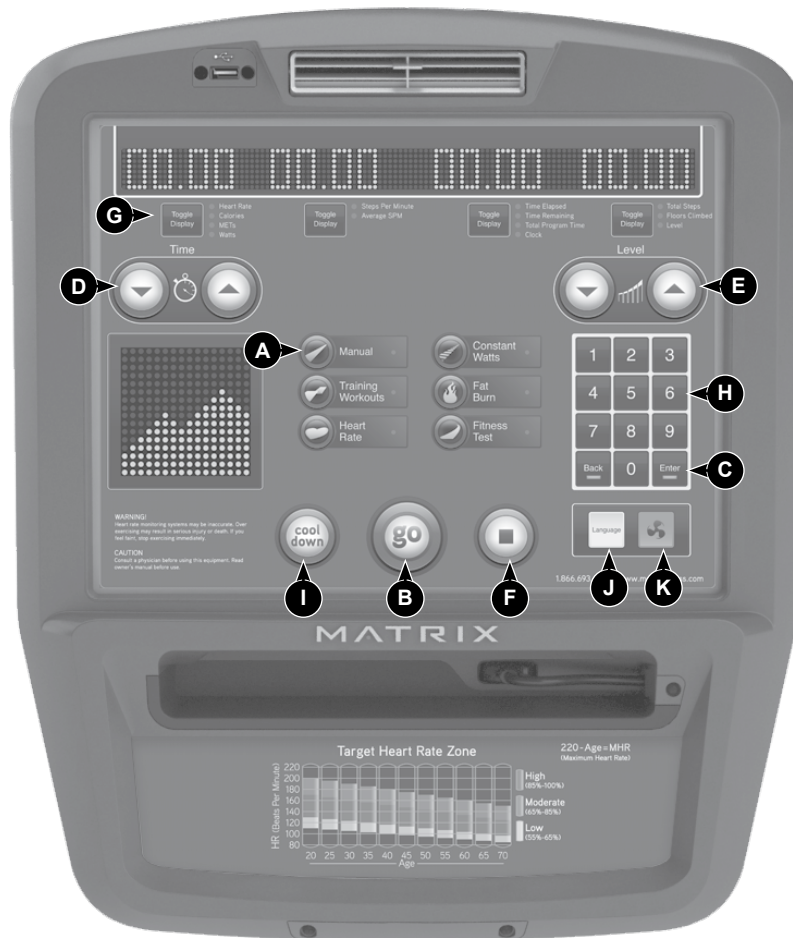

## 5X CONSOLE DESCRIPTION

The Matrix machine is inspected before it is packaged. It is shipped in two pieces: the base and the console. Carefully unpack the unit and dispose of the box material. Note: There is a thin protective sheet of clear plastic on the overlay of the console that should be removed before use.



- A) **WORKOUT KEYS:** Simple program view and selection buttons.
- B) **GO:** One Touch Start.
- C) **ENTER:** To confirm each program setting.
- D) **UP/DOWN TIME:** Easy information and time adjustment.
- E) **UP/DOWN LEVEL:** Easy information and level selection.
- F) **STOP:** Ends workout and shows workout summary data.
- G) **TOGGLE DISPLAY:** Cycles between 2 or 4 rows of workout information displayed in LED window. The console will automatically cycle between the workout information if the Toggle Display button is pushed and held down for 3 seconds.
- H) **NUMBER KEYPAD:** Workout data input for workout setup. Level adjustment during workout.
- I) **COOL DOWN:** Puts the Climbmill into Cool Down mode.
- J) **LANGUAGE:** Select Language.
- K) **FAN:** Allows for fan speed selection (fan has three operating speeds.)



## 7XE CONSOLE DESCRIPTION

The Matrix machine is inspected before it is packaged. It is shipped in two pieces: the base and the console. Carefully unpack the unit and dispose of the box material. Note: There is a thin protective sheet of clear plastic on the overlay of the console that should be removed before use.

The 7xe has a fully integrated touch screen display. All information required for workouts is explained on screen. Exploration of the interface is highly encouraged. The information explaining how to program for various workouts will give an explanation about the contents of each screen on the 7xe.

- A) **GO:** One Touch Start.
- B) **STOP** (displayed on-screen during workout): Ends workout and shows workout summary data.
- C) **COOL DOWN** (displayed on-screen during workout): Puts unit into Cool Down mode. Cool Down time is dependent on the length of the workout. Workouts 19 minutes and shorter will have a cool down length of 2 minutes. Workouts 20 minutes and longer will have a cool down length of 5 minutes.

### 7XE ENTERTAINMENT ZONE

- D) **IPOD®:** Will take the user directly to the iPod screen to allow for iPod control and playlist selection.
- E) **VOLUME UP/DOWN:** Adjusts the volume output through headphones.
- F) **CC/MUTE:** Mutes sound and turns closed captioning on or off.
- G) **NUMBER KEYPAD:** Allows for easy number inputs.
- H) **CHANNEL UP/DOWN:** Allows for channel selection on the integrated console TV.
- I) **DISPLAY MODE:** Allows user to cycle through console display options, iPod, TV or profile display.
- J) **LAST CHANNEL:** Allows the user to cycle between the current channel and the previous channel they were viewing.







## 7XI CONSOLE DESCRIPTION

The Matrix machine is inspected before it is packaged. It is shipped in two pieces: the base and the console. Carefully unpack the unit and dispose of the box material. Note: There is a thin protective sheet of clear plastic on the overlay of the console that should be removed before use.

The 7xi has a fully integrated touch screen display. All information required for workouts is explained on screen. Exploration of the interface is highly encouraged. The information explaining how to program for various workouts will give an explanation about the contents of each screen on the 7xi.

- A) **GO:** One Touch Start.
- B) **STOP** (displayed on-screen during workout): Ends workout and shows workout summary data.
- C) **COOL DOWN** (displayed on-screen during workout): Puts unit into Cool Down mode. Cool Down time is dependent on the length of the workout. Workouts 19 minutes and shorter will have a cool down length of 2 minutes. Workouts 20 minutes and longer will have a cool down length of 5 minutes.

## 7XI ENTERTAINMENT ZONE

- D) **IPOD@:** Will take the user directly to the iPod screen to allow for iPod control and playlist selection.
- E) **VOLUME UP/DOWN:** Adjusts the volume output through headphones.
- F) **CC/MUTE:** Mutes sound and turns closed captioning on or off.
- G) **NUMBER KEYPAD:** Allows for easy number inputs.
- H) **CHANNEL UP/DOWN:** Allows for channel selection on the integrated console TV.
- I) **DISPLAY MODE:** Allows user to cycle through console display options, iPod, TV or profile display.
- J) **LAST CHANNEL:** Allows the user to cycle between the current channel and the previous channel they were viewing.





## GO SCREEN

- Touch the **WORKOUT PROGRAM** of your choice and follow the on-screen prompts or touch **GO** to begin working out.

## 7XI CONSOLE OPERATION

### GETTING STARTED

(For help or more information, touch ?.)

### WELCOME SCREEN

- Touch the **USER** button to sign-in with your XID.
- Touch the **GUEST** button to workout anonymously.
- Touch the **REGISTER** button to create a new XID.

### USER SIGN-IN

- 1) Enter your **XID** and touch ✓ or ⏩.
- 2) Enter your **PASSCODE** and touch ✓ or ⏩.
- 3) A screen will appear showing you are signed-in successfully.















### REGISTER A NEW USER

- 1) Touch **REGISTER**, select **IMPERIAL** or **METRIC** and enter a unique **XID** that is ten digits in length. Touch ✓ or ⏩ to continue.
- 2) Enter your **EMAIL ADDRESS** and touch the ⏩ to continue.
- 3) Enter your 4-digit **PASSCODE** and touch **ENTER** or ⏩ to continue.
- 4) Re-enter your 4-digit **PASSCODE** and touch **ENTER** or ⏩ to continue.
- 5) Select your **GENDER**, enter your **DATE OF BIRTH** (Day-Month-Year) and touch ✓ or ⏩ to continue.
- 6) Enter your **WEIGHT** and touch ✓ or ⏩ to continue.
- 7) Touch ⏪ to go back and change any of your entries. Touch ⏩ to complete registration.
- 8) Your account is now active and you are signed-in.

## FEATURED CONTENT

- When the workout starts, featured content is displayed. Touch  to access homescreen.

## HOMESCREEN

- The **USERNAME** or **GUEST** is shown in the upper right-hand corner.
- Touch  to change **WORKOUT STATISTICS** displayed at the bottom of the screen.
- Touch a **FLAG** to change the language.
- Touch  to go back to the home screen whenever you're using an app.
- Touch  to switch between different audio source (TV, iPod, Virtual Active, Media Player, etc.).
- Touch  to see WiFi or Ethernet connectivity.
- Touch  to display your heart rate.
- Touch  to display current weather warnings in your area.
- Touch  or  buttons to change intensity level and/or speed and to alternate between two (user defined) intensity levels. NOTE: the user will need to confirm a change in speed by touching the flashing 'OK' button on the screen.
- Touch  to end your workout.
- Touch  to temporarily stop your workout and touch  to resume. NOTE: After  is touched, speed, incline and resistance levels be reset.
- Touch  to enter cool down mode. Cool down lasts for a few minutes while reducing the workout intensity, allowing your body to recover from your workout.
- Touch  to prevent accidental screen touches from being implemented. Touch it again to unfreeze the screen and browse through features and make intentional changes to your entertainment or workout.
- Touch  to turn the fan on. There are three fan speeds (low, medium, high).

## HOMESCREEN:



## 7XI APPS AND ENTERTAINMENT



- **FEATURED CONTENT** - Displays featured videos, music and workouts according to frequently-accessed content.
- **SIMPLE** - Workout stats are displayed in 3 customizable windows.
- **PROFILE** - Your workout info is displayed and Virtual Active courses are shown. With Virtual Active, escape the confines of an ordinary workout as you or walk or run through exotic destinations.
- **IPOD** - Connect and control audio and video files on-screen.
- **FACEBOOK** - Browse your Facebook page while you work out.
- **TWITTER** - Access your Twitter feed while you work out.
- **TV** - Watch live TV.
- **WEATHER** - Get local weather info.
- **YOUTUBE** - Browse and watch YouTube videos while you work out.
- **FACILITY** - View Facility event schedule and other info.
- **CHANGE WORKOUT** - Select a different workout without stopping your current workout.

## PROFILE / VIRTUAL ACTIVE SCREEN:



- **MEDIA PLAYER** - Connect and control audio and video files on-screen via USB port.
- **ON DEMAND TV** - Watch On Demand video content while you work out.
- **ON DEMAND MUSIC** - Watch On Demand music content while you work out.
- **MYFITNESSPAL** - Lose weight with MyFitnessPal, the fastest and easiest to use calorie counter.

NOTE: Availability of apps is subject to change. Additional apps may become available.



"Made for iPod" and "Made for iPhone" mean that an electronic accessory has been designed to connect specifically to iPod or iPhone, respectively, and has been certified by the developer to meet Apple performance standards. Apple is not responsible for the operation of this device or its compliance with safety and regulatory standards. Please note that the use of this accessory with iPod or iPhone may affect wireless performance. iPod and iPhone are trademarks of Apple Inc., registered in the U.S. and other countries.

# NIKE + IPOD INSTRUCTIONS (7XE CONSOLES ONLY)



## REQUIREMENTS

Nike + iPod – compatible iPod or iPhone (See [www.apple.com/nikeplus](http://www.apple.com/nikeplus) for more information).

Before syncing your Apple device, you must first create a free Nike + iPod account at [www.nikerunning.com](http://www.nikerunning.com) and have the Nike + iPod App turned on in the settings of your device.

## GETTING STARTED

- 1) Before connecting your Apple device, you must first turn on Nike + iPod within the settings of the device.
- 2) Dock your Apple device and wait for authentication to complete. This may take up to 10 seconds. After authentication is complete, your iPod-specific console controls will be active (see next page).
- 3) If your iPod or iPhone is Nike Plus compatible, your workout will begin recording automatically to your Nike + iPod – compatible device.
- 4) When your workout is complete, your workout data will be recorded to your Nike Plus compatible device.
- 5) Log into your Nike Running account to review and track your workouts.



“Made for iPod” means that an electronic accessory has been designed to connect specifically to iPod and has been certified by the developer to meet Apple performance standards. Apple is not responsible for the operation of this device or its compliance with safety and regulatory standards. iPod is a trademark of Apple Inc., registered in the U.S. and other countries.

## MANAGER MODE AND ENGINEERING MODE

### 3X & 5X CONSOLES:

These sections allow users to manipulate default settings for the machines. It may be accessed by pressing the **Level Up/Level Down** keys simultaneously for 5 seconds. To change a setting, press “**Enter**” on the keypad under ‘Manager Mode’ or ‘Engineering Mode’ and use the level buttons and numeric keypad to enter a category and change the values. Pressing “**Enter**” again will save the change. Pressing “**Back**” or “**Stop**” will bring you to the previous menu. To exit Manager or Engineering Mode, hold “**Stop**” down for 5 seconds. Below is a list of the settings that can be changed.

MANAGER MODE SETTINGS:		ENGINEERING MODE SETTINGS:	
Default Age	Language	Disable Errors	Club ID
Default Weight	Max Speed Level	Speed Units	ErP Time
Default Height	Software Version	Machine Type	AM System
Default Time	Speed/Distance Mode	Power Save Time	Audio Source
Default Floors	Out of Order	Pause Time	Volume Control
Default Calories	Gender	Serial Number	
Accumulated Time	Sound Mode	E-Stop Switch	
Accumulated Floors	Maximum Time	E-Stop Setting	

### 7XE AND 7XI CONSOLES:

These sections allow users to manipulate default settings for the machines. Manager Mode may be accessed by pressing **ENTER, 1, 0, 0, 1, Enter** on the keypad. Engineering Mode may be accessed by pressing **ENTER, 2, 0, 0, 1, Enter** on the keypad. The screen shots on the next page show what you will see when you enter Manager Mode and Engineering Mode.

This console has a fully integrated touch screen display. Lightly touch the screen and use the intuitive interface to adjust the settings. Any and all changes made will be saved when the “**home**” button is touched in the upper left-hand corner of the screen. Touching the “**home**” button will exit manager or engineering mode and return you to the main screen. It is not necessary to touch this button after each setting is changed.



## 7XE - MANAGER AND ENGINEERING MODE

**MATRIX**  
Manager Mode

Serial Number

Accumulated Distance **3059 mi**

Accumulated Time **580 hrs**

Software Versions

Out of Order **Off**

CSafe Model **On**

Platform: **FFTM501E110700168**

Console: **CTM503F110700003**

These values can not be modified.

home About Time Speed Defaults TV Language Other

English Dutch French Italian Spanish Norwegian Portuguese 中文 日本語

**MATRIX**  
Engineering Mode

Auto Calibration

Manual Cal Elevation Min **4000**

Manual Cal Elevation Max **29000**

Calibration Status

Start

home Calibration Statistics Errors Clubs Club ID Other

English Dutch Scan Italian Spanish Norwegian Portuguese 中文 日本語

## 7XI - MANAGER AND ENGINEERING MODE

English  
**MATRIX**  
7xi Manager Mode

General

Workout

Setup Defaults

Asset Management

Weather

TV

Applications

Hardware

Accumulated Time **0 hrs**

Accumulated Distance **0 mi**

Serial Number - Console **empty**

Serial Number - Frame **empty**

Serial Number - Frame **empty**

page 1 of 3

↑ ↓ ← →

English  
**MATRIX**  
7xi Engineering Mode

General

Workout

Setup Defaults

Network

Asset Management

Weather

TV

Applications

Accumulated Time **0 hrs**

Accumulated Distance **0 mi**

Serial Number - Console **empty**

Serial Number - Frame **empty**

Serial Number - Frame **empty**

Out of Order **True**  **False**

False

page 1 of 3

↑ ↓ ← →







# CLIMBMILL WORKOUTS



## **NOTE:**

The individual human power required to perform an exercise may be different than the mechanical power displayed.

These exercise devices are Class A products. These products display the power input into the exercise device in watts. These products have been tested to ensure that the watts displayed on the console is accurate to within +/- 10 %.

The testing parameters used to determine watts accuracy were:

- Training speed of 120 SPM (60 steps per foot);
- Range of motion (step height) of approximately 200 mm;
- Level set to the following levels: 1, 5, 10, 20, and maximum level.

## WORKOUT DESCRIPTIONS

### QUICK START OPERATION

Press the **GO** button and the machine will enter into a manual mode of operation. All energy expenditure values will be calculated using the default weight measurement.

### MANUAL WORKOUT OPERATION

Manual is a workout that allows you to manually adjust the intensity level at anytime. The manual workout also contains a setup screen which allows you to input your weight to help calculate a more accurate caloric burn rate.

To enter into this workout on the 3x and 5x, use the following guidelines. To enter into this workout on the 7xe and 7xi, follow the on-screen prompts.

- 1) Choose **MANUAL** by selecting the manual workout button and press **ENTER**.
- 2) Enter the desired intensity level using the **ARROW KEYS** or **NUMBER KEYPAD** and press **ENTER**.
- 3) Enter the desired workout length using the **ARROW KEYS** or the **NUMBER KEYPAD** and press **ENTER**.
- 4) Enter user weight (user weight is used to calculate the caloric expenditure value-providing an accurate weight helps to ensure an accurate caloric expenditure rating for each user) using the **ARROW KEYS** or the **NUMBER KEYPAD** and press **ENTER**.
- 5) Press **GO** to begin the workout.

### RANDOM (3X ONLY)

There are 20 workout profiles in random mode. Profile will change each time random button is pressed.

To enter into this workout on the 3x, use the following guidelines.

- 1) Press the **RANDOM** button and choose a workout profile.
- 2) Enter your desired intensity level using the **ARROW KEYS** or **NUMBER KEYPAD** and press **ENTER**.
- 3) Enter your desired Time using the **ARROW KEYS** or **NUMBER KEYPAD** and press **ENTER**.
- 4) Enter user weight (user weight is used to calculate the caloric expenditure value-providing an accurate weight helps to ensure an accurate caloric expenditure rating for each user) using the **ARROW KEYS** or the **NUMBER KEYPAD** and press **ENTER**.
- 5) Press **GO** to begin the workout.

NOTE: Programs may vary based on model and default settings.



## TRAINING WORKOUTS

Your Matrix machine offers a variety of level-based workouts to challenge users of all fitness levels. The following information will briefly explain the workout and how to program the machine for each workout selection.

### A) ROLLING HILLS

Rolling hills is a level-based workout that automatically adjusts the intensity level to simulate walking or running up hills.

To enter into this workout on the 3x and 5x, use the following guidelines. To enter into this workout on the 7xe and 7xi, follow the on-screen prompts.

- 1) Press the **TRAINING WORKOUTS** button until **ROLLING HILLS** is displayed and press **ENTER**.
- 2) Enter the desired intensity level using the **ARROW KEYS** or the **NUMBER KEYPAD** and press **ENTER**.
- 3) Enter the desired workout length using the **ARROW KEYS** or the **NUMBER KEYPAD** and press **ENTER**.
- 4) Enter user weight (user weight is used to calculate the caloric expenditure value-providing an accurate weight helps to ensure an accurate caloric expenditure rating for each user) using the **ARROW KEYS** or the **NUMBER KEYPAD** and press **ENTER**.
- 5) Press **GO** to begin the workout.

### B) INTERVAL TRAINING

Interval Training is a level-based workout that automatically adjusts the intensity in a series of low- to high-intensity levels.

To enter into this workout on the 3x and 5x, use the following guidelines. To enter into this workout on the 7xe and 7xi, follow the on-screen prompts.

- 1) Press the **TRAINING WORKOUTS** button until **INTERVALS TRAINING** is displayed and press **ENTER**.
- 2) Enter the desired intensity level using the **ARROW KEYS** or the **NUMBER KEYPAD** and press **ENTER**.
- 3) Enter the desired workout length using the **ARROW KEYS** or the **NUMBER KEYPAD** and press **ENTER**.
- 4) Enter user weight (user weight is used to calculate the caloric expenditure value-providing an accurate weight helps to ensure an accurate caloric expenditure rating for each user) using the **ARROW KEYS** or the **NUMBER KEYPAD** and press **ENTER**.
- 5) Press **GO** to begin the workout.

NOTE: Programs may vary based on model and default settings.



## WORKOUT DESCRIPTIONS

### C) CALORIE TRAINING

Calorie Training is a target-based workout that is designed to help users burn a target number of calories.

To enter into this workout on the 3x and 5x, use the following guidelines. To enter into this workout on the 7xe and 7xi, follow the on-screen prompts.

- 1) Press the **TRAINING WORKOUTS** button until **CALORIE TRAINING** is displayed and press **ENTER**.
- 2) Enter the desired intensity level using the **ARROW KEYS** or the **NUMBER KEYPAD** and press **ENTER**.
- 3) Enter user weight (user weight is used to calculate the caloric expenditure value - providing an accurate weight helps to ensure an accurate caloric expenditure rating for each user) using the **ARROW KEYS** or the **NUMBER KEYPAD** and press **ENTER**.
- 4) Enter the desired calorie to burn using the **ARROW KEYS** or the **NUMBER KEYPAD** and press **ENTER**.
- 5) Press **GO** to begin the workout.

### D) GOAL TRAINING

Goal Training is a goal-based workout that is designed to help users burn a target number of calories.

To enter into this workout on the 3x and 5x, use the following guidelines. To enter into this workout on the 7xe and 7xi, follow the on-screen prompts.

- 1) Press the **TRAINING WORKOUTS** button until **GOAL TRAINING** is displayed and press **ENTER**.
- 2) Enter the desired floor to climb using the **ARROW KEYS** or the **NUMBER KEYPAD** and press **ENTER**.
- 3) Enter the desired intensity level using the **ARROW KEYS** or the **NUMBER KEYPAD** and press **ENTER**.
- 4) Enter user weight (user weight is used to calculate the caloric expenditure value - providing an accurate weight helps to ensure an accurate caloric expenditure rating for each user) using the **ARROW KEYS** or the **NUMBER KEYPAD** and press **ENTER**.
- 5) Press **GO** to begin the workout.

NOTE: Programs may vary based on model and default settings.



## HEART RATE

Your Matrix machine offers a heart rate control workout mode. The heart rate control workout mode allows the user to program their desired heart rate zone and the machine will automatically adjust the level based upon the user's heart rate. The heart rate zone is calculated using the following equation:  $(220 - \text{Age}) * \% = \text{target heart rate zone}$ . The user must wear a telemetric heart rate monitor or continually hold onto the contact heart rate grips for this workout.

To enter into this workout on the 3x and 5x, use the following guidelines. To enter into this workout on the 7xe and 7xi, follow the on-screen prompts.

- 1) Choose **HEART RATE** by selecting the target heart rate workout button and press **ENTER**.
- 2) Enter age using the **ARROW KEYS** or the **NUMBER KEYPAD** and press **ENTER**.
- 3) Enter the desired percent of maximum heart rate using the **ARROW KEYS** and press **ENTER**.
- 4) Enter the desired workout length using the **ARROW KEYS** or the **NUMBER KEYPAD** and press **ENTER**.
- 5) Enter user weight (user weight is used to calculate the caloric expenditure value, providing an accurate weight helps to ensure an accurate caloric expenditure rating for each user) using the **ARROW KEYS** or the **NUMBER KEYPAD** and press **ENTER**.
- 6) Press **GO** to begin the workout.

## CONSTANT WATTS

This program allows you to vary your cadence or SPM and the machine's resistance will adjust accordingly to your selected goal. The quicker your stride the less resistance for the goal selected.

To enter into this workout on the 3x and 5x, use the following guidelines. To enter into this workout on the 7xe and 7xi, follow the on-screen prompts.

- 1) Press **CONSTANT WATTS**
- 2) Enter your **WEIGHT** using the **ARROW KEYS** or **NUMBER KEYPAD** and press **ENTER**.
- 3) Enter your desired **WATT** using the **ARROW KEYS** or **NUMBER KEYPAD** and press **ENTER**.
- 4) Enter your desired **TIME** using the **ARROW KEYS** or **NUMBER KEYPAD** and press **ENTER**.
- 5) Press **GO** to begin the workout.

NOTE: Programs may vary based on model and default settings.



## WORKOUT DESCRIPTIONS

### FAT BURN WORKOUT OPERATION

Fat burn is a level-based workout that is designed to help users burn fat through various resistance changes.

To enter into this workout on the 3x and 5x, use the following guidelines. To enter into this workout on the 7xe and 7xi, follow the on-screen prompts.

- 1) Choose **FAT BURN** by selecting the fat burn workout button and press **ENTER**.
- 2) Enter the desired intensity level using the **ARROW KEYS** or the **NUMBER KEYPAD** and press **ENTER**.
- 3) Enter the desired workout length using the **ARROW KEYS** or the **NUMBER KEYPAD** and press **ENTER**.
- 4) Enter user weight (user weight is used to calculate the caloric expenditure value-providing an accurate weight helps to ensure an accurate caloric expenditure rating for each user) using the **ARROW KEYS** or the **NUMBER KEYPAD** and press **ENTER**.
- 5) Press **GO** to begin the workout.

NOTE: Programs may vary based on model and default settings.

### FITNESS TESTS

#### WFI

The WFI (Wellness Fitness Initiative) protocol is a test used by firefighters to evaluate aerobic fitness capacity as part of pre-employment testing and annual fitness testing. This assessment is a series of intervals lasting a maximum of 16 minutes, where the speed is increased every minute until the Target Heart Rate is exceeded for 15 seconds. When the test is complete, the display provides a summary of VO2max, Highest SPM, Elapsed Time and Target Heart Rate. This is a speed-dependent program.

#### CPAT

The Candidate Physical Ability Test (CPAT) is a new minimum requirement for the position of Firefighter. The job of a Firefighter is one of the most physically demanding jobs in North America. Participants wear a 50-pound (22.68-kg) vest to simulate the weight of self-contained breathing apparatus (SCBA) and firefighter protective clothing. An additional 25 pounds (11.34 kg), using two 12.5-pound (5.67-kg) weights that simulate a high-rise pack (hose bundle), is added to your shoulders for the stair climb event. The candidate must maintain 60 SPM (steps per minute) for 3 minutes.

## SUBMAXIMAL

This test measures cardiovascular fitness and provides an estimated Sub-maximal VO<sub>2</sub>max result. This assessment

is a 4 stage test lasting 3-5 minutes, where the speed is increased until your Heart Rate is held between 115-150bpm for 2 of the stages. When the test is complete, a Fitness Rating is displayed as High, Good, Average, Fair or Low along with your age and VO<sub>2</sub>max.

The test requires constant monitoring of the user's heart rate so the use of a telemetric chest strap is highly encouraged.

To enter into these workouts on the 3x and 5x, use the following guidelines. To enter into these workouts on the 7xe and 7xi, follow the on-screen prompts.

- 1) Choose a **FITNESS TEST** by pressing the Fitness Test workout button until the desired Fitness Test appears and press **ENTER**.
  - a) The **WFI** program requires users to enter their age, weight, and height.
  - b) The **CPAT** program does not require additional entries from the user.
  - c) The **SUBMAXIMAL** program requires users to enter their age, gender and weight.
- 4) Press **GO** to begin the workout.

FITNESS RATING NORMS (VO <sub>2</sub> MAX)						
	AGE	20-29	30-39	40-49	50-59	60+
<b>MEN</b>						
	HIGH	51.4 +	50.4 +	48.2 +	45.3 +	42.5 +
	GOOD	51.3 - 46.8	50.3 - 44.6	48.1 - 41.8	45.2 - 38.5	42.4 - 35.3
	AVERAGE	46.7 - 42.5	44.5 - 41.0	41.7 - 38.1	38.4 - 35.2	35.2 - 31.8
	FAIR	42.4 - 39.5	40.9 - 37.4	38.0 - 35.1	35.1 - 32.3	31.7 - 28.7
	LOW	39.4 OR LESS	37.3 OR LESS	35.0 OR LESS	32.2 OR LESS	28.6 OR LESS
<b>WOMEN</b>						
	HIGH	44.2 +	41.0 +	39.5 +	35.2 +	35.2 +
	GOOD	44.1 - 38.1	40.9 - 36.7	39.4 - 33.8	35.1 - 30.9	35.1 - 29.4
	AVERAGE	38.0 - 35.2	36.6 - 33.8	33.7 - 30.9	30.8 - 28.2	29.3 - 25.8
	FAIR	35.1 - 32.3	33.7 - 30.5	30.8 - 28.3	28.1 - 25.5	25.7 - 23.8
	LOW	32.2 OR LESS	30.4 OR LESS	28.2 OR LESS	25.4 OR LESS	23.7 OR LESS

<sup>1</sup> THE AMERICAN COLLEGE OF SPORTS MEDICINE, GUIDELINES FOR EXERCISE TESTING AND PRESCRIPTION, 6TH EDITION, LIPPINCOTT WILLIAMS & WILKINS, PHILADELPHIA, PA 2000, P.77

NOTE: Programs may vary based on model and default settings.





# PRODUCT SPECIFICATIONS





## PRODUCT SPECIFICATIONS

	C7xi CLIMBMILL	C7xe CLIMBMILL	C5x CLIMBMILL
<b>FEATURES</b>			
STEP HEIGHT	10" / 25.4 CM	10" / 25.4 CM	10" / 25.4 CM
CONTACT & WIRELESS HR	YES	YES	YES
ULTRA NON-SLIP PEDALS	YES	YES	YES
HANDLEBAR DESIGN	ERGONOMICALLY DESIGNED HANDRAILS AND HORN	ERGONOMICALLY DESIGNED HANDRAILS AND HORN	ERGONOMICALLY DESIGNED HANDRAILS AND HORN
THUMB SWITCH CONTROLS	YES	YES	YES
<b>RESISTANCE SYSTEM</b>			
TECHNOLOGY	ECB W/ FLYWHEEL	ECB W/ FLYWHEEL	ECB W/ FLYWHEEL
POWER REQUIREMENTS	POWERED 100-125 V, 60 HZ OR 216-250 V, 50 HZ	POWERED 100-125 V, 60 HZ OR 216-250 V, 50 HZ	POWERED 100-125 V, 60 HZ OR 216-250 V, 50 HZ
MINIMUM WATTS	N/A	N/A	N/A
<b>CONSOLE</b>			
DISPLAY TYPE	16" / 40.6 CM CLASS PROJECTIVE CAPACITIVE TOUCH SCREEN LCD (16.9)	15" / 38.1 CM TOUCH SCREEN LCD	DOT-MATRIX LED
DISPLAY FEEDBACK	TIME ELAPSED, TIME REMAINING, TOTAL PROGRAM TIME, CLOCK, HEART RATE, CALORIES, CALORIES PER HOUR, METS, WATTS, STEPS PER MINUTE, AVERAGE SPM, TOTAL STEPS, FLOORS CLIMBED, LEVEL, STATIC PROFILE DISPLAY, HD DYNAMIC PROFILE DISPLAY	TIME ELAPSED, TIME REMAINING, TOTAL PROGRAM TIME, CLOCK, HEART RATE, CALORIES, CALORIES PER HOUR, METS, WATTS, STEPS PER MINUTE, AVERAGE SPM, TOTAL STEPS, FLOORS CLIMBED, LEVEL, STATIC PROFILE DISPLAY, DYNAMIC PROFILE DISPLAY	TIME ELAPSED, TIME REMAINING, TOTAL PROGRAM TIME, CLOCK, HEART RATE, CALORIES, METS, WATTS, STEPS PER MINUTE, AVERAGE SPM, TOTAL STEPS, FLOORS CLIMBED, LEVEL, STATIC PROFILE DISPLAY
USER DEFINED MULTI-LANGUAGE DISPLAY	YES - ENGLISH, GERMAN, FRENCH, ITALIAN, SPANISH, DUTCH, PORTUGUESE, CHINESE, JAPANESE, KOREAN, SWEDISH, FINNISH, RUSSIAN, ARABIC	YES - ENGLISH, GERMAN, FRENCH, ITALIAN, SPANISH, DUTCH, PORTUGUESE, CHINESE, JAPANESE, KOREAN, SWEDISH, FINNISH, RUSSIAN, ARABIC	YES - ENGLISH, GERMAN, FRENCH, ITALIAN, SPANISH, DUTCH, PORTUGUESE, JAPANESE, SWEDISH, FINNISH, JAPANESE
RESISTANCE LEVELS	25	25	25
WORKOUTS	MANUAL, TRAINING WORKOUTS (ROLLING HILL, INTERVAL TRAINING, CALORIE TRAINING, GOAL TRAINING), FAT BURN, TARGET HEART RATE, FITNESS TEST (SUB-MAXIMAL TEST, CPAT, WFI TEST), CONSTANT WATTS, VIRTUAL ACTIVE, GOAL-BASED WORKOUTS	MANUAL, TRAINING WORKOUTS (ROLLING HILL, INTERVAL TRAINING, CALORIE TRAINING, GOAL TRAINING), FAT BURN, TARGET HEART RATE, FITNESS TEST (SUB-MAXIMAL TEST, CPAT, WFI TEST), CONSTANT WATTS	MANUAL, TRAINING WORKOUTS (ROLLING HILL, INTERVAL TRAINING, CALORIE TRAINING, GOAL TRAINING), FAT BURN, TARGET HEART RATE, FITNESS TEST (SUB-MAXIMAL TEST, CPAT, WFI TEST), CONSTANT WATTS
CSAFE READY - FITLINXX™ CERTIFIED	YES	YES	YES
NETPULSE COMPATIBLE	YES	NO	YES
FIT TOUCH TECHNOLOGY™	YES	YES	NO
ON-THE-FLY PROGRAM CHANGE	YES	YES	YES
INTEGRATED VISTA CLEAR™ DIGITAL READY TELEVISION	16" / 40.6 CM CLASS PROJECTIVE CAPACITIVE TOUCH SCREEN LCD (16.9)	YES - 15" / 38.1 CM SCREEN SIZE	NO
VIRTUAL ACTIVE™ COMPATIBLE	YES - INCLUDED	YES	NO
FITCONNEXION™ READY	NO	NO	YES
WIFI	YES	YES	YES
ETHERNET PORT	YES	YES	YES
WEB CONNECTIVITY	YES-CUSTOM APP INTERFACE IN ADDITION TO WEB BROWSER	NO	NO
FACILITY COMMUNICATOR PORTAL/ CALENDAR	YES-PROGRAMMED THROUGH ASSET MANAGEMENT	NO	NO
ASSET MANAGEMENT COMPATIBLE	YES - INCLUDED	YES	YES
IPOD® COMPATIBLE	YES	YES	YES - CHARGING ONLY
IPHONE® COMPATIBLE	YES	YES - CHARGING ONLY	YES - CHARGING ONLY
USB PORT	YES	YES	YES
MULTIMEDIA PLAYBACK	YES - THROUGH USB PORT (COMPATIBLE WITH MOST POPULAR TABLET AND SMART PHONE SYSTEMS)	NO	NO
NIKE + IPOD COMPATIBLE	NO	YES	NO
PERSONAL FAN	YES	YES	YES
<b>TECH SPECS</b>			
OVERALL DIMENSIONS	65" X 33.5" X 83.5"	65" X 33.5" X 83.5"	65" X 33.5" X 83.5"
L X W X H	165CM X 85CM X 212CM	165CM X 85CM X 212CM	165CM X 85CM X 212CM
MAXIMUM USER WEIGHT	400 LBS/182 KG	400 LBS/182 KG	400 LBS/182 KG
WEIGHT	348LBS/158KGS	348LBS/158KGS	348LBS/158KGS
SHIPPING WEIGHT	368LBS/167KGS	368LBS/167KGS	368LBS/167KGS

NON AMERICAN SPECIFICATIONS SHOWN. SPECIFICATIONS SUBJECT TO CHANGE. FOR LATEST SPECIFICATIONS PLEASE VISIT [WWW.MATRIXFITNESS.COM](http://WWW.MATRIXFITNESS.COM)



	C3x CLIMBMILL
<b>FEATURES</b>	
STEP HEIGHT	10" / 25.4 CM
CONTACT & WIRELESS HR	YES
ULTRA NON-SLIP PEDALS	YES
HANDLEBAR DESIGN	ERGONOMICALLY DESIGNED HANDRAILS AND HORN
THUMB SWITCH CONTROLS	YES
<b>RESISTANCE SYSTEM</b>	
TECHNOLOGY	ECB W/ FLYWHEEL
POWER REQUIREMENTS	POWERED 100-125 V, 60 HZ OR 216-250 V, 50 HZ
MINIMUM WATTS	N/A
<b>CONSOLE</b>	
DISPLAY TYPE	14-SEG ALPHANUMERIC, 8/16 LED GRAPHIC DISPLAY
DISPLAY FEEDBACK	TIME ELAPSED, TIME REMAINING, TOTAL PROGRAM TIME, HEART RATE, CALORIES, METS, WATTS, STEPS PER MINUTE, SPEED, FLOORS CLIMBED, LEVEL, STATIC PROFILE DISPLAY
USER DEFINED MULTI-LANGUAGE DISPLAY	NO - ACCESSIBLE THROUGH MANAGER MENU: ENGLISH, GERMAN, FRENCH, ITALIAN, SPANISH, DUTCH, PORTUGUESE, SWEDISH, FINNISH
RESISTANCE LEVELS	25
WORKOUTS	MANUAL, ROLLING HILLS, INTERVAL TRAINING, FAT BURN, RANDOM, FITNESS TESTS (SUB-MAXIMAL TEST, WFI TEST, CPAT)
CSAFE READY - FITLINX™ CERTIFIED	YES
NETPULSE COMPATIBLE	YES
FIT TOUCH TECHNOLOGY™	NO
ON-THE-FLY PROGRAM CHANGE	YES
INTEGRATED VISTA CLEAR™ DIGITAL READY TELEVISION	NO
VIRTUAL ACTIVE™ COMPATIBLE	NO
FITCONNEXION™ READY	YES
WIFI	NO
ETHERNET PORT	YES
WEB CONNECTIVITY	NO
FACILITY COMMUNICATOR PORTAL/ CALENDAR	NO
ASSET MANAGEMENT COMPATIBLE	NO
IPOD® COMPATIBLE	NO
IPHONE® COMPATIBLE	NO
USB PORT	YES
MULTIMEDIA PLAYBACK	NO
NIKE + IPOD COMPATIBLE	NO
PERSONAL FAN	NO
<b>TECH SPECS</b>	
OVERALL DIMENSIONS L X W X H	65" X 33.5" X 83.5" 165CM X 85CM X 212CM
MAXIMUM USER WEIGHT	400 LBS/182 KG
WEIGHT	335LBS/155KGS
SHIPPING WEIGHT	368LBS/167KGS

**NORTH AMERICAN SPECIFICATIONS SHOWN. SPECIFICATIONS SUBJECT TO CHANGE. FOR LATEST SPECIFICATIONS PLEASE VISIT [WWW.MATRIXFITNESS.COM](http://WWW.MATRIXFITNESS.COM)**







1-866-693-4863  
[www.matrixfitness.com](http://www.matrixfitness.com)

Matrix Fitness  
1600 Landmark Drive,  
Cottage Grove, WI 53527