

CABLE MOTION / MULTI JUNGLE

Owner's Manual

01/25/11 8314401 REV B-2



LifeFitness
WHAT WE LIVE FOR

CORPORATE HEADQUARTERS

5100 River Road
Schiller Park, Illinois 60176 • U.S.A.
847.288.3300 • FAX: 847.288.3703
800.735.3867 (Toll-free within U.S.A., Canada)
Global Website: www.lifefitness.com

INTERNATIONAL OFFICES

AMERICAS

North America Life Fitness Inc.

5100 N River Road
Schiller Park, IL 60176 U.S.A.
Telephone: (847) 288 3300
Fax: (847) 288 3703
Service Email: customersupport@lifefitness.com
Sales/Marketing Email: commercialsales@lifefitness.com
Operating Hours: 7:00 am-6:00 pm (CST)

Brazil

Life Fitness Brasil

Av. Cidade Jardim, 900
Jd. Paulistano
São Paulo, SP 01454-000
BRAZIL
SAC: 0800 773 8282
Telephone: +55 (11) 3095 5200
Fax: +55 (11) 3095 5201
Service Email: suporte@lifefitness.com.br
Sales/Marketing Email: lifefitness@lifefitness.com.br
Service Operating Hours:
9:00 - 17:00 (BRT) (Monday-Friday)
Store Operating Hours:
9:00 -20:00 (BRT) (Monday-Friday)
10:00 - 16:00 (BRT) (Saturday)

Latin America & Caribbean*

Life Fitness Inc.

5100 N River Road
Schiller Park, IL 60176 U.S.A.
Telephone: (847) 288 3300
Fax: (847) 288 3703
Service Email: customersupport@lifefitness.com
Sales/Marketing Email: commercialsales@lifefitness.com
Operating Hours: 7:00am-6:00pm (CST)

EUROPE, MIDDLE EAST, & AFRICA (EMEA)

Netherlands & Luxemburg Life Fitness Atlantic BV

Bijdorplein 25-31
2992 LB Barendrecht
THE NETHERLANDS
Telephone: (+31) 180 646 666
Fax: (+31) 180 646 699
Service Email: service.benelux@lifefitness.com
Sales/Marketing Email:
marketing.benelux@lifefitness.com
Operating Hours: 9.00h-17.00h (CET)

United Kingdom & Ireland Life Fitness UK LTD

Queen Adelaide
Ely, Cambs, CB7 4UB
Telephone: General Office (+44) 1353.666017
Customer Support (+44) 1353.665507
Fax: (+44) 1353.666018
Service Email: uk.support@lifefitness.com
Sales/Marketing Email: life@lifefitness.com
Operating Hours:
General Office: 9.00am - 5.00pm (GMT)
Customer Support: 8.30am - 5.00pm (GMT)

Germany & Switzerland Life Fitness Europe GMBH

Siemensstraße 3
85716 Unterschleißheim
GERMANY
Telephone: (+49) 89.31 77 51.0 (Germany)
(+41) 0848 000 901 (Switzerland)
Fax: (+49) 89.31 77 51.99 (Germany)
(+41) 043 818 07 20 (Switzerland)
Service Email: kundendienst@lifefitness.com
Sales/Marketing Email: kundenberatung@lifefitness.com
Operating Hours: 08.30 - 16.30h (CET)

Austria

Life Fitness Austria

Vertriebs G.m.b.H.
Dückerstraße 7-9/3/36
1220 Vienna
AUSTRIA
Telephone: (+43) 1.61.57.198
Fax: (+43) 1.61.57.198.20
Service Email: kundendienst@lifefitness.com
Marketing/Sales Email: kundenberatung@lifefitness.com
Operating Hours: 9.00h-17.00h (MEZ)

Spain

Life Fitness IBERIA

C/Frederic Mompou 5,1ªª
08960 Sant Just Desvern Barcelona
SPAIN
Telephone: (+34) 93.672.4660
Fax: (+34) 93.672.4670
Service Email: info.iberia@lifefitness.com
Sales/Marketing Email: info.iberia@lifefitness.com
Operating Hours:
9.00h-18.00h (Monday-Thursday)
8.30h-15.00h (Friday)

Belgium

Life Fitness Benelux NV

Parc Industriel de Petit-Rechain
4800 Verviers
BELGIUM
Telephone: (+32) 87 300 942
Fax: (+32) 87 300 943
Service Email:
internationalservicesupport@lifefitness.com
Sales/Marketing Email:
marketing.benelux@lifefitness.com
Operating Hours: 9.00h - 17.00h (CET)

Italy

Life Fitness Europe GmbH

Siemensstraße 3
85716 Unterschleißheim
GERMANY
Telephone: (+39) 02-55378611
Service: 800438836 (In Italy)
Fax: (+39) 02-55378699
Service Email: assistentatecnica@lifefitness.com
Sales/Marketing Email: info@lifefitnessitalia.com
Operating Hours: 08:30 - 16:30h (CET)

All Other EMEA countries & distributor business C-EMEA*

Bijdorplein 25-31
2992 LB Barendrecht
THE NETHERLANDS
Telephone: (+31) 180 646 644
Fax: (+31) 180 646 699
Service Email: service.db.cemea@lifefitness.com
Sales/Marketing Email:
marketing.db.cemea@lifefitness.com
Operating Hours: 9.00h-17.00h (CET)

ASIA PACIFIC (AP)

Japan

Life Fitness Japan

Nippon Brunswick Bldg., #8F
5-27-7 Sendagaya
Shibuya-Ku, Tokyo
Japan 151-0051
Telephone: (+81) 3.3359.4309
Fax: (+81) 3.3359.4307
Service Email: service@lifefitnessjapan.com
Sales/Marketing Email: sales@lifefitnessjapan.com
Operating Hours: 9.00h-17.00h (JAPAN)

China and Hong Kong

Life Fitness Asia Pacific LTD

Room 2610, Miramar Tower
132 Nathan Road
Tsimshatsui, Kowloon
HONG KONG
Telephone: (+852) 2891.6677
Fax: (+852) 2575.6001
Service Email: HongKongEnquiry@lifefitness.com
Sales/Marketing Email: ChinaEnquiry@lifefitness.com
Operating Hours: 9.00h-18.00h

All Other Asia Pacific countries & distributor business Asia Pacific*

Room 2610, Miramar Tower
132 Nathan Road
Tsimshatsui, Kowloon
HONG KONG
Telephone: (+852) 2891.6677
Fax: (+852) 2575.6001
Service Email: HongKongEnquiry@lifefitness.com
Sales/Marketing Email: ChinaEnquiry@lifefitness.com
Operating Hours: 9.00h-18.00h

* Also check www.lifefitness.com for local representation or distributor/dealer.

TABLE OF CONTENTS

Section	Description
1.	Safety Information
2.	Warranty
3.	Contact Information
4.	General Specifications
5.	Exercises
6.	Maintenance

1. SAFETY INFORMATION

It is the sole responsibility of the purchaser of LIFE FITNESS products to read the owner's manual and warning labels and instruct all individuals, whether they are the end user or supervising personnel, on proper usage of the equipment.

UNDERSTANDING EACH AND EVERY WARNING TO THE FULLEST IS IMPORTANT. IF ANY OF THESE WARNINGS ARE UNCLEAR, CONTACT LIFE FITNESS CUSTOMER SERVICE IMMEDIATELY AT 1-800-735-3867.

This equipment is categorized as class S per EN 957-1. As such this equipment is only intended for commercial, institutional and/or studio facilities. It is not intended for home use. Contact LIFE FITNESS with any questions regarding this classification.

It is recommended that all users of LIFE FITNESS exercise equipment be informed of the following information prior to use.



ACCESS CONTROL

LIFE FITNESS recommends that all commercial fitness equipment be used in a supervised area. It is recommended that the equipment be located in an access controlled area. Control is the responsibility of the facility owner.



INSTALLATION

SECURING EQUIPMENT - LIFE FITNESS recommends that all equipment be secured to a solid, level surface to stabilize it and eliminate rocking or tipping over. This must be performed by a licensed contractor.



PROPER USAGE

1. Do not use any equipment in any way other than designed or intended by the manufacturer. It is imperative that LIFE FITNESS equipment is used properly to avoid injury.
2. Injuries may result if exercising improperly or excessively. It is recommended that all individuals consult a physician prior to commencing an exercise program. If at any time during exercise you feel faint, dizzy or experience pain, STOP EXERCISING and consult your physician.
3. Keep body parts (hands, feet, hair, etc.), clothing and jewelry away from moving parts to avoid injury.
4. When adjusting any seat, knee hold down pad, range of motion limiter, foothold pad, pulley or any other type of adjuster, make certain that the adjusting pin is fully engaged in the hole to avoid injury.



INSPECTION

1. DO NOT use or permit use of any equipment that is damaged and/or has worn or broken parts. For all LIFE FITNESS equipment use only replacement parts supplied by LIFE FITNESS.
2. Cables and belts pose an extreme liability if used when frayed. Always replace any cable at first sign of wear (consult LIFE FITNESS if uncertain).
3. Routinely inspect all accessory clips that join attachments to the cables and replace them at the first sign of wear.
4. MAINTAIN LABELS AND NAME PLATES - Do not remove labels for any reason. They contain important information. If unreadable or missing, contact LIFE FITNESS for a replacement.
5. EQUIPMENT MAINTENANCE - Preventative maintenance is the key to smooth operating equipment as well as to keep your liability to a minimum. Equipment needs to be inspected at regular intervals.
6. Ensure that any person(s) making adjustments or performing maintenance or repair of any kind is qualified to do so. LIFE FITNESS will provide service and maintenance training at our corporate facility upon request or in the field if proper arrangements are made.
7. Before any use, examine all accessories approved for use with the LIFE FITNESS equipment for damage or wear.
8. DO NOT ATTEMPT TO USE OR REPAIR ANY ACCESSORY APPROVED FOR USE WITH THE LIFE FITNESS EQUIPMENT WHICH APPEARS TO BE DAMAGED OR WORN.



OPERATING WARNINGS

1. It is the purchaser's sole responsibility to properly instruct its end users and supervising personnel as to the proper operating procedures of all LIFE FITNESS equipment.
2. Keep children away from strength equipment. Parents or others supervising children must provide close supervision of children if the equipment is used in the presence of children.
3. Do not allow users to wear loose fitting clothing or jewelry while using equipment. It is also recommended to have users secure long hair back and up to avoid contact with moving parts.
4. All bystanders must stay clear of all users, moving parts and attached accessories and components while machine is in operation.



PLATE LOADED, FREE WEIGHT AND BODY WEIGHT SYSTEMS

1. If the unit is equipped with weight rods, use only Olympic style weight plates (2.0" bore) for training weight. Do not use dumbbells or any means other than those stated to increase weight resistance - See machine specific section for more information.
2. Always utilize weight plate retention devices such as clamps or pins.
3. Only add weight plates up to the load limits of the unit. Make sure all weight plates are completely placed on the weight rod.
4. Never exceed the load rating for any plate loaded station, body weight station, bench or other free weight device; including specific weight rod and band peg limits - See machine specific section for load limit information.
5. Contact a Life Fitness representative with any questions regarding proper weights and loading.



SELECTORIZED WEIGHT STACK SYSTEMS

1. Use only weight selector pins supplied by LIFE FITNESS on weight stacks. Substitutes are forbidden.
2. Fully insert weight selector pins. Partial insertion can cause weights to fall unexpectedly.
3. Never pin the weight stack in an elevated position.
4. Never remove selector pin if any weights are suspended.
5. Never attempt to release jammed weights or parts.
6. Never use dumbbells or other means to incrementally increase the weight resistance. Use only those means provided by LIFE FITNESS.

2. WARRANTY

WHAT IS COVERED

This Life Fitness commercial exercise equipment is warranted to be free of all defects in material and workmanship.

WHO IS COVERED

The original purchaser or any person receiving the product as a gift from the original purchaser.

WHO PAYS TRANSPORTATION & INSURANCE FOR SERVICE

If the Product or any covered part must be returned to a service facility for repairs, We, Life Fitness, will pay all transportation and insurance charges for the first year. You are responsible for transportation and insurance charge after the first year.

WHAT WE WILL DO TO CORRECT COVERED DEFECTS

We will ship to you any new or rebuilt replacement part or component, or at our option, replace the Product. Such replacement parts are warranted for the remaining portion of the original warranty period.

WHAT IS NOT COVERED

Any failures or damage caused by unauthorized service, misuse, accident, negligence, improper assembly or installation, debris resulting from any construction activities in the Product's environment, rust or corrosion as a result of the Product's location, alterations or modifications without our written authorization, or by failure on your part to use, operate and maintain the Product as set out in you Operation Manual.

All terms of this warranty are void if this product is moved beyond the continental borders of the United States of America (excluding Alaska, Hawaii and Canada) and are then subject to the terms provided by that country's local authorized Life Fitness representative.

OPERATION MANUAL

It is VERY IMPORTANT THAT YOU READ THIS MANUAL before operating the Product. Remember to perform the periodic maintenance requirements specified in the Manual to assure proper operation and your continued satisfaction.

EXCLUSIVE WARRANTY

THIS LIMITED WARRANTY IS IN LIEU OF ALL OTHER WARRANTIES OF ANY KIND EITHER EXPRESSED OR IMPLIED, INCLUDING BUT NOT LIMITED TO THE IMPLIED WARRANTIES OF MERCHANTABILITY AND FITNESS FOR A PARTICULAR PURPOSE, AND ALL OTHER OBLIGATIONS OR LIABILITIES ON OUR PART. We neither assume nor authorize any person to assure for us any other obligation or liability concerning the sale of this Product. Under no circumstances shall we be liable under this warranty, or otherwise, of any damage to any person or property, including any lost profits or lost savings, for any special, indirect, secondary, incidental or consequential damages of any nature arising out of the use of or inability to use this Product. Some states do not allow the exclusion or limitation of implied warranties or of liability for incidental or consequential damages, so the above limitations or exclusions may not apply to you.

CHANGES IN WARRANTY NOT AUTHORIZED

No one is authorized to change, modify or extend the terms of this limited warranty.

EFFECTS OF STATE LAWS

This warranty gives you specific legal rights, and you may have other rights which vary from state to state.

OUR PLEDGE TO YOU

Our Products are designed and manufactured to the highest standards.

We want you to be completely satisfied with our Products and will do everything possible under the terms of this warranty to keep you secure in knowing you have bought the best!

HOW TO OBTAIN PARTS & SERVICE

1. Verify the symptom and review the operating instructions. The problem may be unfamiliarity with the product and its features and workouts.
2. Locate and write down the serial number of the unit.
3. Contact the nearest Life Fitness Customer Support Services group.

WARRANTY COVERAGE

*There is no warranty coverage for labor on Strength Products.

Structural Frame (Not coatings)	Guide Rods / Pulleys/ Weight Plates	Bearings / Grip / Cables	Hardware / Belt / Springs / Mechanical
10 years	5 years	1 year	90 Days

3. CONTACT INFORMATION

For Product Service within the United States and Canada:

Toll-free: 800-735-3867

Please call Monday through Friday from 7:00 a.m. to 6:00 p.m. Central Standard Time, and tell them your name, address, and serial number of your Product. They will tell you how to get a replacement part, or if necessary, arrange for service where your Product is located or advise you on how and where to ship the Product for service. Before shipping:

1. **Obtain** a Return Authorization Number (**RA#**) from Customer Support Services
2. Securely **pack** your Product (use the original shipping carton, if possible)
3. **Write** the **RA#** on the outside of the carton
4. **Insure** the Product
5. **Include** a letter explaining the defect or problem and a copy of your proof of purchase if you believe the service is covered by warranty.

Return address:

Life Fitness World Headquarters

Attn: CSS Help Desk

5100 N. River Rd.

Schiller Park, IL 60176

For Product Service Internationally see contact information listed on page one of this manual.

4. GENERAL SPECIFICATIONS

Cable Motion Dual Adjustable Pulley (CMDAP)

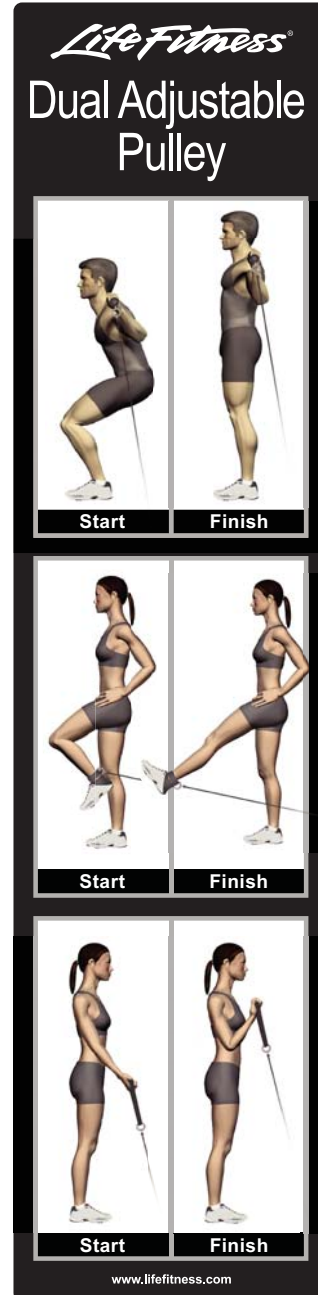
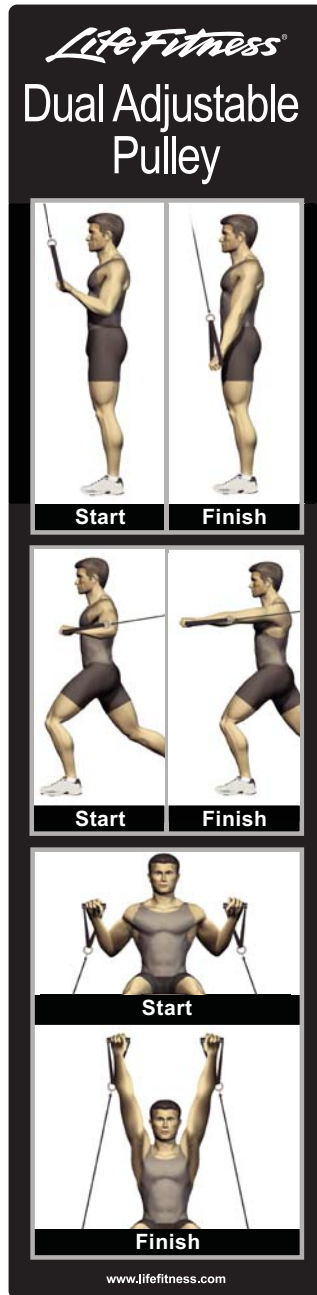

EXERCISE AND SETUP:

For a complete list of exercises and how to perform them please see exercise sections 5-A & 5-B.

Product Code - CMDAP

Machine Weight (with pull up handles):	1301 lbs	590 kg
Machine Weight (without pull up handles):	1274 lbs	578 kg
Max User Weight:	300 lbs	136 kg
Resistance Ratio:	1:4	
Weight Stack:	2 x 390 lbs	2 x 177 kg
Effective User Resistance:	2 x 97.5 lbs	2 x 44.25 kg

PRODUCT DIMENSIONS WITH WORKING AREA (CMDAP)

Size (w/ pull up handles): in. = 45"L x 62"W x 94"H cm = 113cmL x 156cmW x 240cmH

Size (w/o pull up handles): in. = 45"L x 62"W x 93"H cm = 113cmL x 156cmW x 235cmH

Live Area: in. = 217"L x 410"W x 112"H cm = 551cmL x 1041cmW x 285cmH

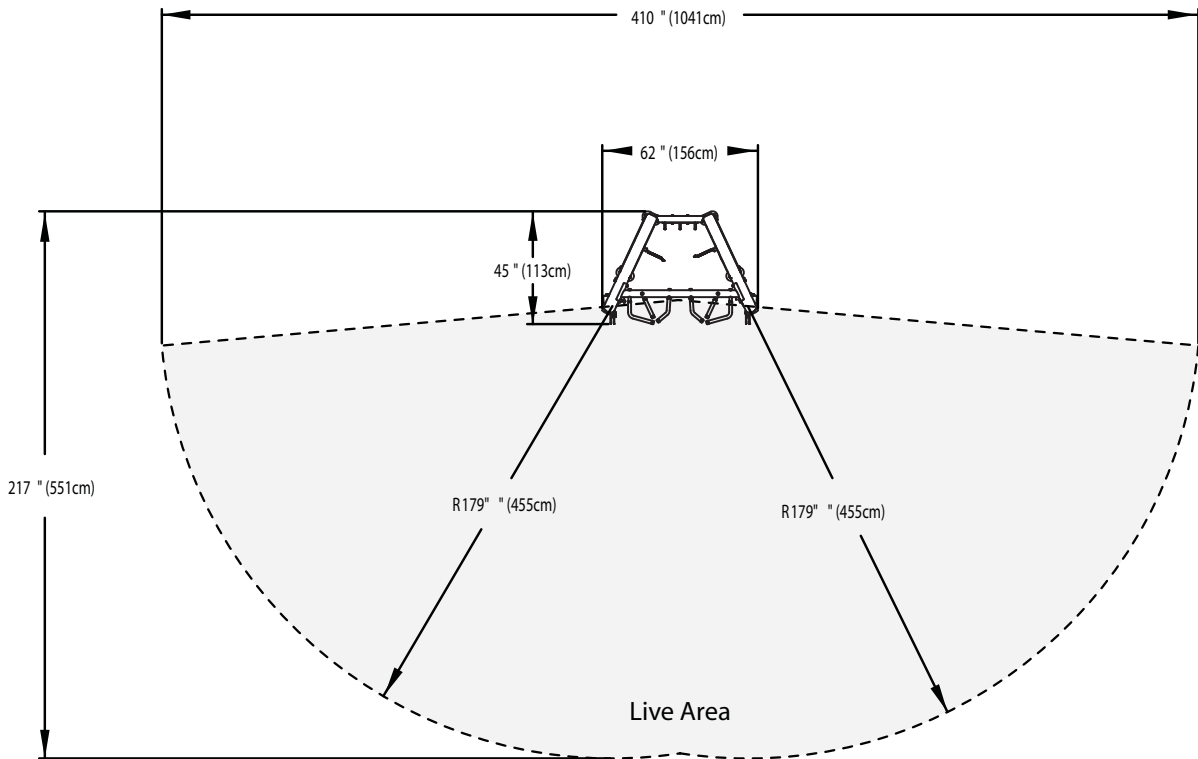

LABEL LOCATIONS (CMDAP)

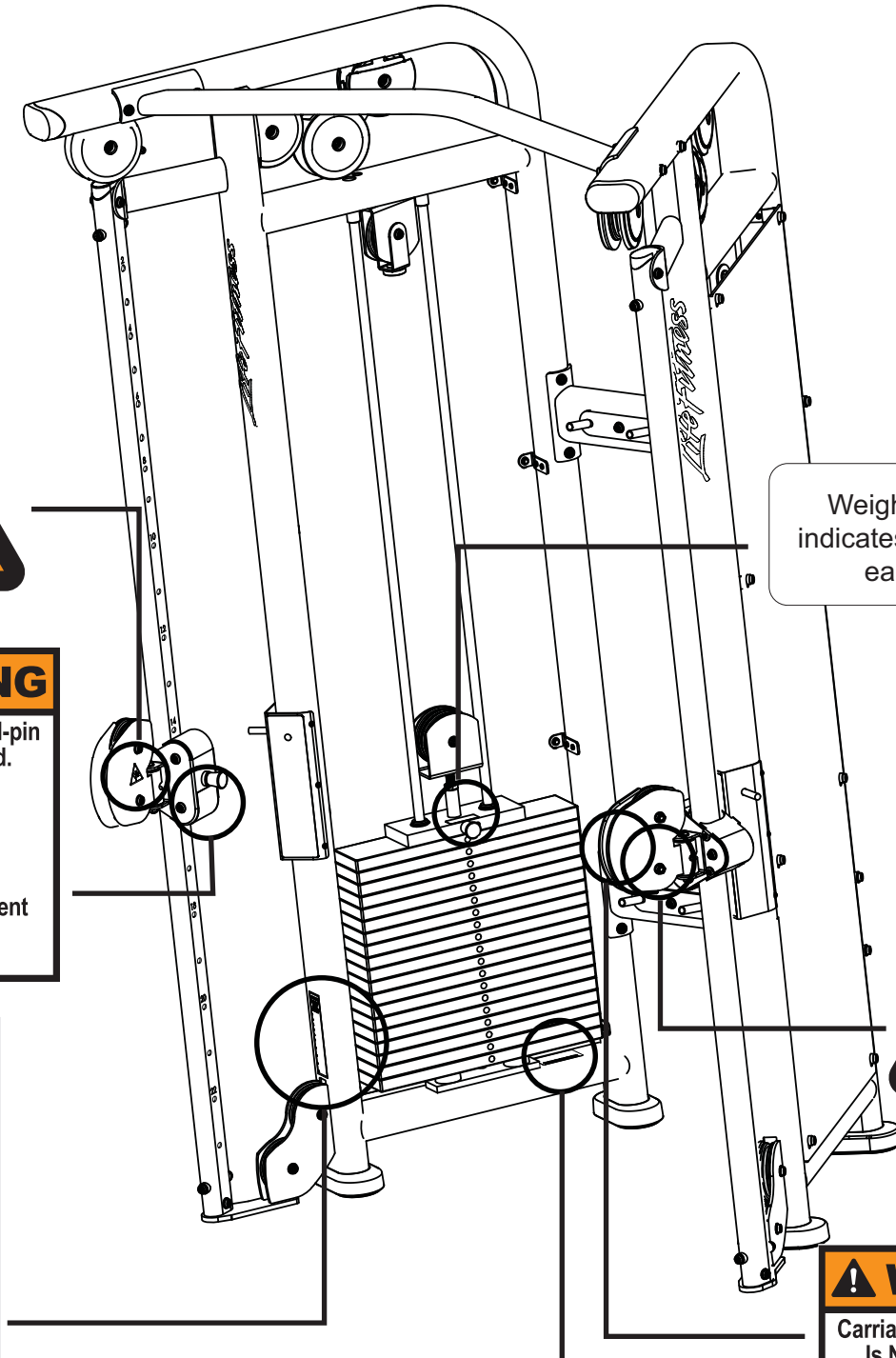

Weight stack label indicates resistance for each handle



WARNING

Carriage Will Fall If Pull-pin Is Not Fully Engaged.



Ensure Full Engagement As Illustrated Here To Avoid Injury.



WARNING

SERIOUS INJURY CAN OCCUR ON THIS EQUIPMENT. YOU MUST FOLLOW THESE PRECAUTIONS TO AVOID INJURY!

- Before using, read all the warnings and obtain instruction on the use of this machine. Use only for intended exercise. **DO NOT** modify the machine.
- Obtain a medical exam before beginning any exercise program.
- Keep body, hair and clothing free of all moving objects.
- Inspect the machines before use. **DO NOT** use if it appears damaged. **DO NOT** attempt to fix a broken or jammed machine. Notify staff immediately.
- Be certain that weight pin is completely inserted. Use only the pin provided by the manufacturer. If unsure, seek assistance.
- Never pin the weights or prop plate into an elevated position. **DO NOT** use the machine if found in this condition. **DO NOT** attempt to fix. Seek assistance.
- Inspect cables and their connections before using machine. **DO NOT** attempt to fix. Seek assistance.
- Use only the incremental weights supplied by the manufacturer. **DO NOT** use dumbbells or other means to add resistance to the machine.
- Children must not be allowed near this machine. Supervise teenagers.
- Manufacturer recommends that all equipment be secured to the floor to stabilize and eliminate rocking or tipping over. Use a licensed contractor.
- DO NOT REMOVE THIS LABEL. REPLACE IF DAMAGED.**

Life Fitness
Schiller Park, IL WWW.LIFEFITNESS.COM

MODEL: CMDAP
MADE IN: MANUFACTURED IN THE USA WITH US AND FOREIGN COMPONENTS
MAX USER WEIGHT: 300 LBS (136kg)
MAX USER TRAINING WEIGHT: 2 x 390lbs (2 x 195kg)
CLASS: S-STUDIO SER. NO. XXXXXXXXXXXXX



WARNING

Carriage Will Fall If Pull-pin Is Not Fully Engaged.



Ensure Full Engagement As Illustrated Here To Avoid Injury.

Cable Motion Cable Column (CMCC)

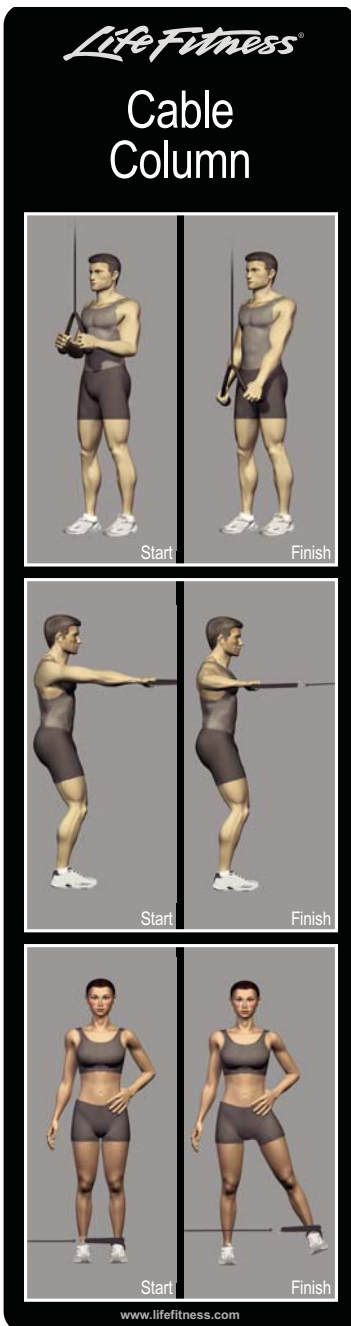

EXERCISE AND SETUP:

For a complete list of exercises and how to perform them please see exercise section 5-A.

Product Code - CMCC

Machine Weight:	525 lbs	238 kg
Max User Weight:	300 lbs	136 kg
Resistance Ratio:	1:4 per handle	
Weight Stack:	190 lbs	95 kg
Effective User Resistance:	2 x 47.5 lbs	2 x 23.75 kg

PRODUCT DIMENSIONS WITH WORKING AREA (CMCC)

Size: in. = 56"L x 57"W x 94"H cm = 143cmL x 144cmW x 239cmH
Live Area: in. = 244"L x 398"W cm = 619cmL x 1011cmW

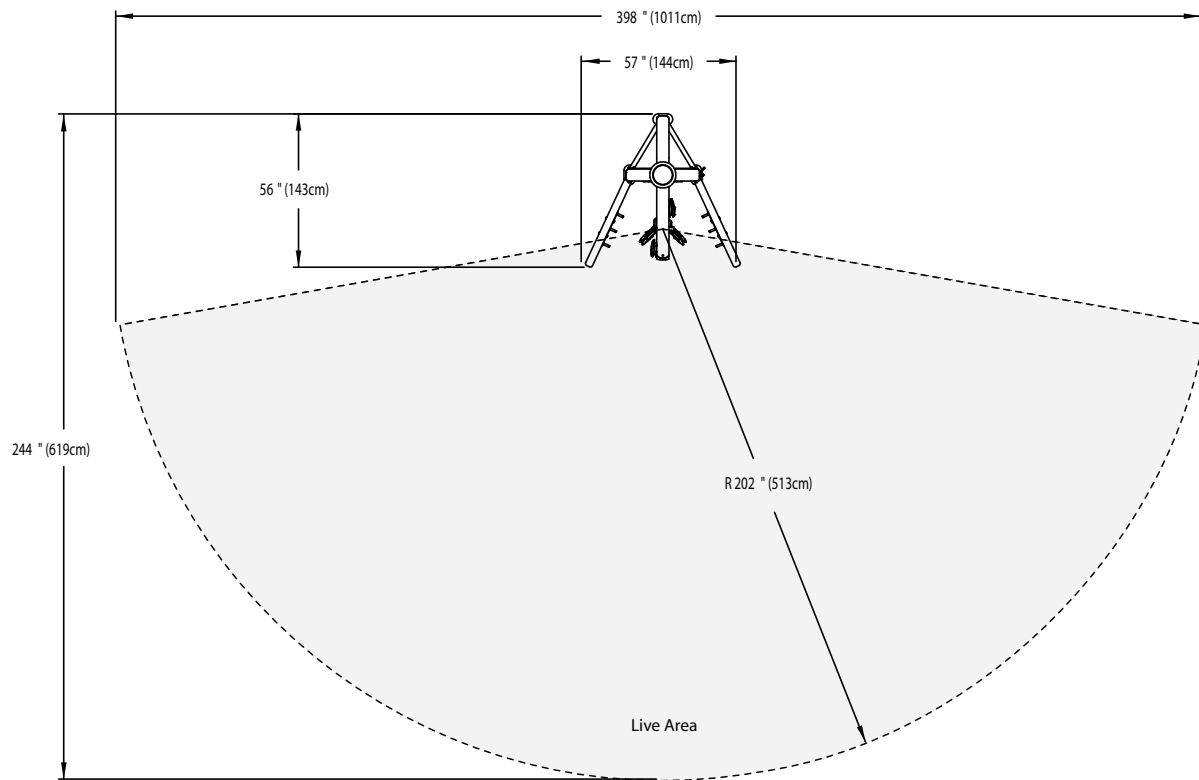

LABEL LOCATIONS (CMCC)

Weight stack label indicates resistance for each handle

! WARNING

Carriage Will Fall If Pull-pin Is Not Fully Engaged. Ensure Full Engagement To Avoid Injury.

! WARNING

Carriage Will Fall If Pull-pin Is Not Fully Engaged.



Ensure Full Engagement As Illustrated Here To Avoid Injury.

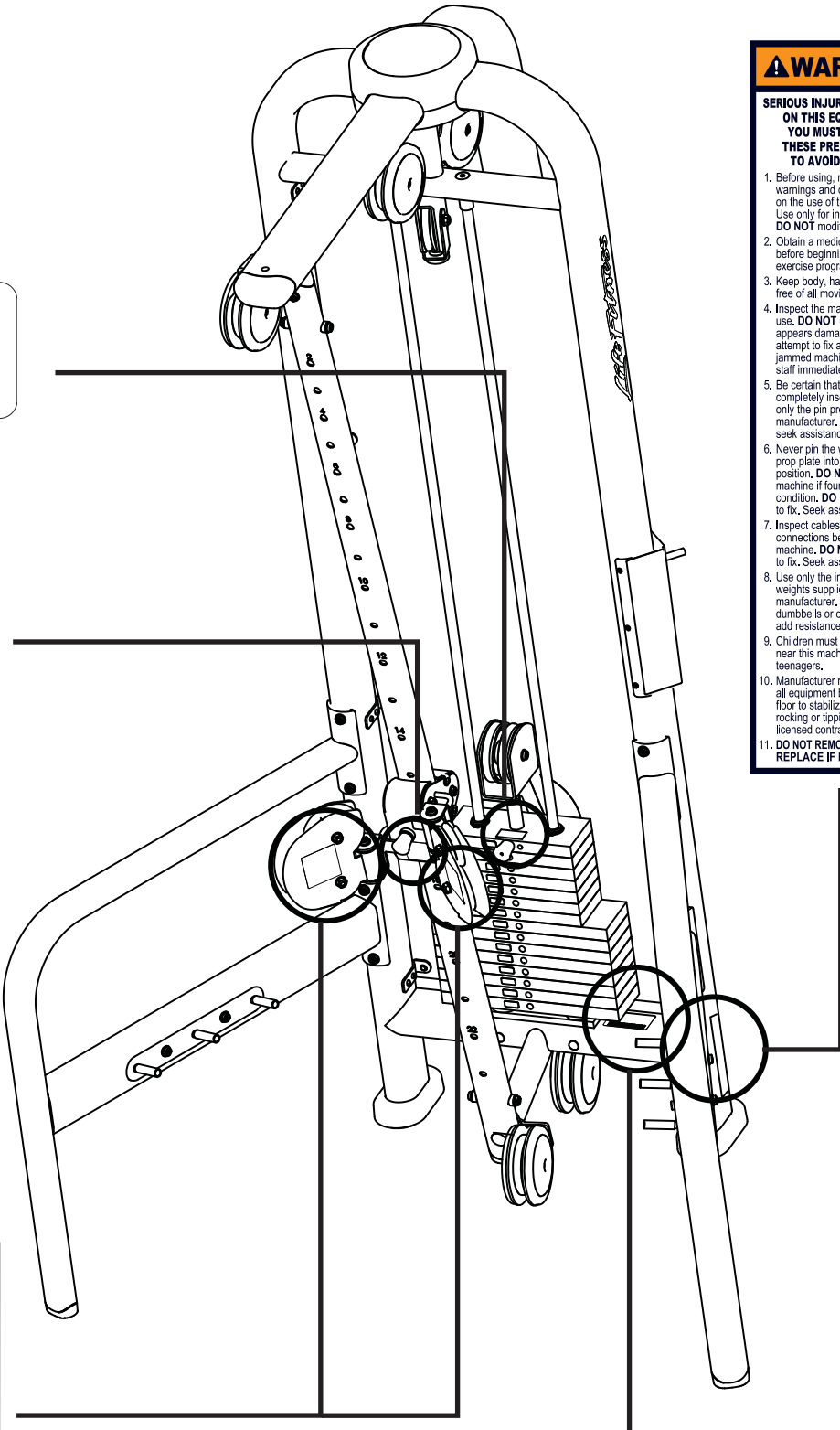



! WARNING

SERIOUS INJURY CAN OCCUR ON THIS EQUIPMENT. YOU MUST FOLLOW THESE PRECAUTIONS TO AVOID INJURY!

1. Before using, read all the warnings and obtain instruction on the use of this machine. Use only for intended exercise. **DO NOT** modify the machine.
2. Obtain a medical exam before beginning any exercise program.
3. Keep body, hair and clothing free of all moving objects.
4. Inspect the machines before use. **DO NOT** use if it appears damaged. **DO NOT** attempt to fix a broken or jammed machine. Notify staff immediately.
5. Be certain that weight pin is completely inserted. Use only the pin provided by the manufacturer. If unsure, seek assistance.
6. Never pin the weights or prop plate into an elevated position. **DO NOT** use the machine if found in this condition. **DO NOT** attempt to fix. Seek assistance.
7. Inspect cables and their connections before using machine. **DO NOT** attempt to fix. Seek assistance.
8. Use only the incremental weights supplied by the manufacturer. **DO NOT** use dumbbells or other means to add resistance to the machine.
9. Children must not be allowed near this machine. Supervise teenagers.
10. Manufacturer recommends that all equipment be secured to the floor to stabilize and eliminate rocking or tipping over. Use a licensed contractor.
11. **DO NOT REMOVE THIS LABEL. REPLACE IF DAMAGED.**

Life Fitness
Schiller Park, IL WWW.LIFEFITNESS.COM

MODEL: CMCC
MADE IN: MANUFACTURED IN THE USA WITH US AND FOREIGN COMPONENTS
MAX. USER WEIGHT: 300 LBS (136kg)
MAX. USER TRAINING WEIGHT: 190lbs (95kg)
CLASS: S-STUDIO SER. NO. XXXXXXXXXXXXX

Cable Motion Adjustable Cable Crossover (CMACO)

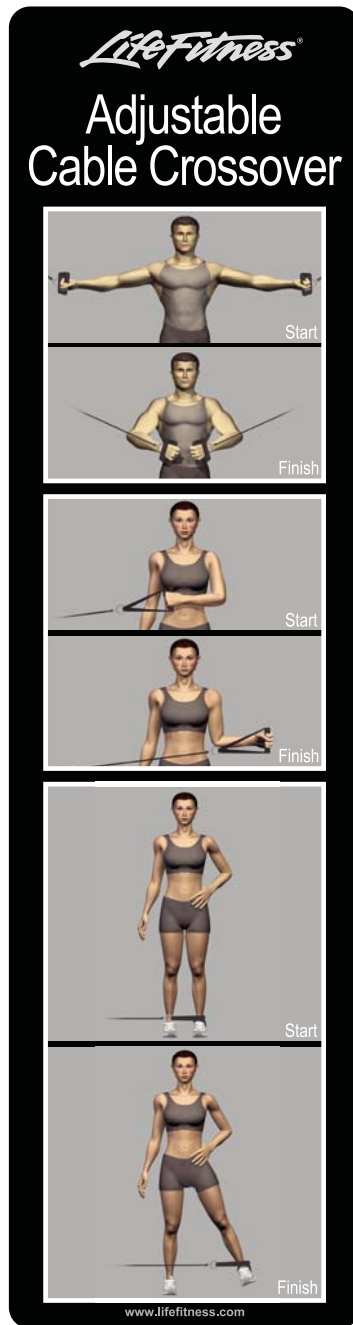

EXERCISE AND SETUP:

For a complete list of exercises and how to perform them please see exercise sections 5-A & 5-C.

Product Code - CMACO

Machine Weight:	992 lbs	450 kg
Max User Weight:	300 lbs	136 kg
Resistance Ratio:	1:2	
Weight Stack:	2 x 190 lbs	2 x 95 kg
Effective User Resistance:	2 x 95 lbs	2 x 47.50 kg

PRODUCT DIMENSIONS WITH WORKING AREA (CMACO)

Size: in. = 168"L x 31"W x 94"H cm = 426cmL x 79cmW x 239cmH
Live Area: in. = 116"L x 256"W cm = 293cmL x 650cmW

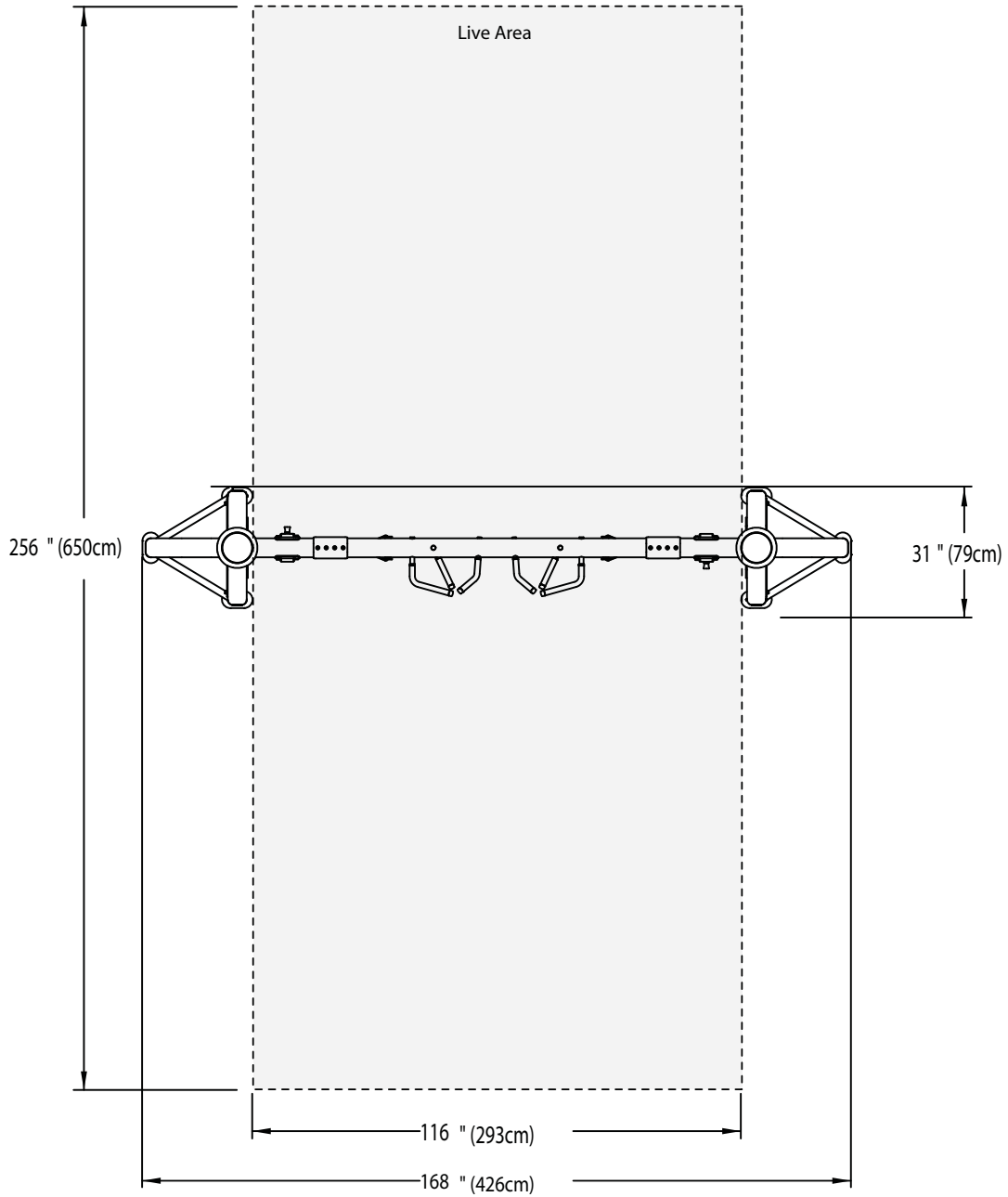

LABEL LOCATIONS (CMACO)

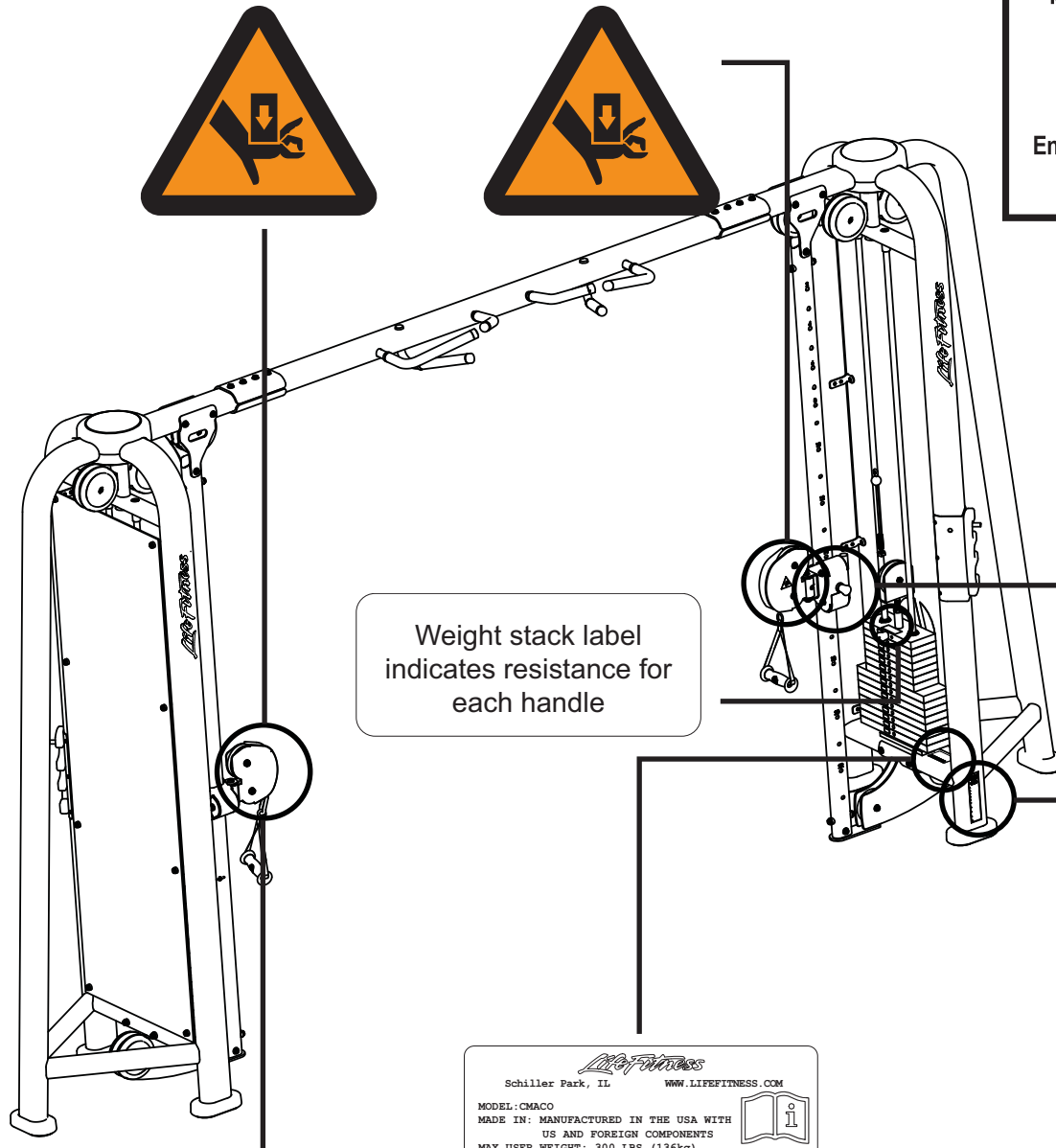

! WARNING

Carriage Will Fall If Pull-pin Is Not Fully Engaged.





Ensure Full Engagement As Illustrated Here To Avoid Injury.

Weight stack label indicates resistance for each handle

Life Fitness
Schiller Park, IL WWW.LIFEFITNESS.COM

MODEL:CMACO
MADE IN: MANUFACTURED IN THE USA WITH US AND FOREIGN COMPONENTS
MAX. USER WEIGHT: 300 LBS (136kg)
MAX. USER TRAINING WEIGHT: 190lbs (95kg)
CLASS:S-STUDIO SER.NO. XXXXXXXXXXXX

! WARNING

Carriage Will Fall If Pull-pin Is Not Fully Engaged.



Ensure Full Engagement As Illustrated Here To Avoid Injury.

! WARNING

SERIOUS INJURY CAN OCCUR ON THIS EQUIPMENT. YOU MUST FOLLOW THESE PRECAUTIONS TO AVOID INJURY!

1. Before using, read all the warnings and obtain instruction on the use of this machine. Use only for intended exercise. **DO NOT** modify the machine.
2. Obtain a medical exam before beginning any exercise program.
3. Keep body, hair and clothing free of all moving objects.
4. Inspect the machines before use. **DO NOT** use if it appears damaged. **DO NOT** attempt to fix a broken or jammed machine. Notify staff immediately.
5. Be certain that weight pin is completely inserted. Use only the pin provided by the manufacturer. If unsure, seek assistance.
6. Never pin the weights or prop plate into an elevated position. **DO NOT** use the machine if found in this condition. **DO NOT** attempt to fix. Seek assistance.
7. Inspect cables and their connections before using machine. **DO NOT** attempt to fix. Seek assistance.
8. Use only the incremental weights supplied by the manufacturer. **DO NOT** use dumbbells or other means to add resistance to the machine.
9. Children must not be allowed near this machine. Supervise teenagers.
10. Manufacturer recommends that all equipment be secured to the floor to stabilize and eliminate rocking or tipping over. Use a licensed contractor.
11. **DO NOT REMOVE THIS LABEL. REPLACE IF DAMAGED.**

Cable Motion Fixed Cable Crossover (CMFCO)

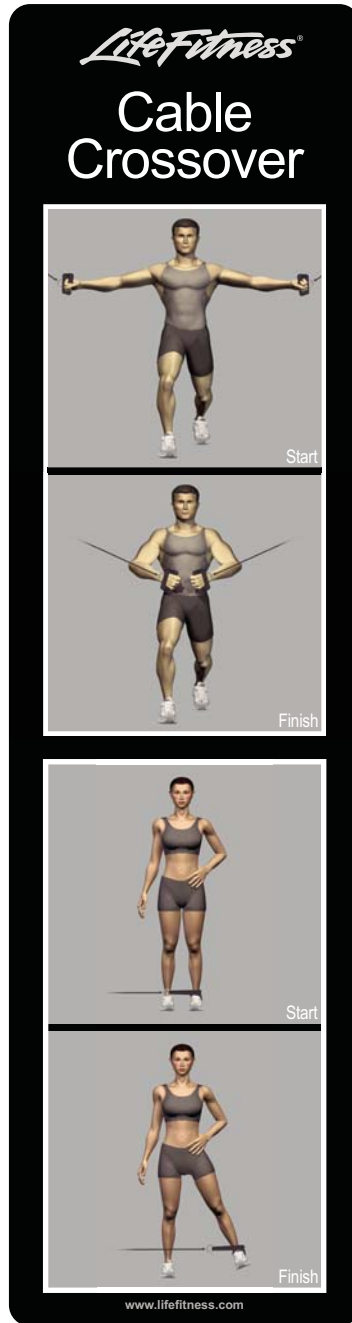

EXERCISE AND SETUP:

For a complete list of exercises and how to perform them please see exercise sections 5-A & 5-C.

Product Code - CMFCO

Machine Weight:	895 lbs	406 kg
Max User Weight:	300 lbs	136 kg
Resistance Ratio:	1:2	
Weight Stack:	2 x 190 lbs	2 x 95 kg
Effective User Resistance:	2 x 95 lbs	2 x 47.50 kg

PRODUCT DIMENSIONS WITH WORKING AREA (CMFCO)

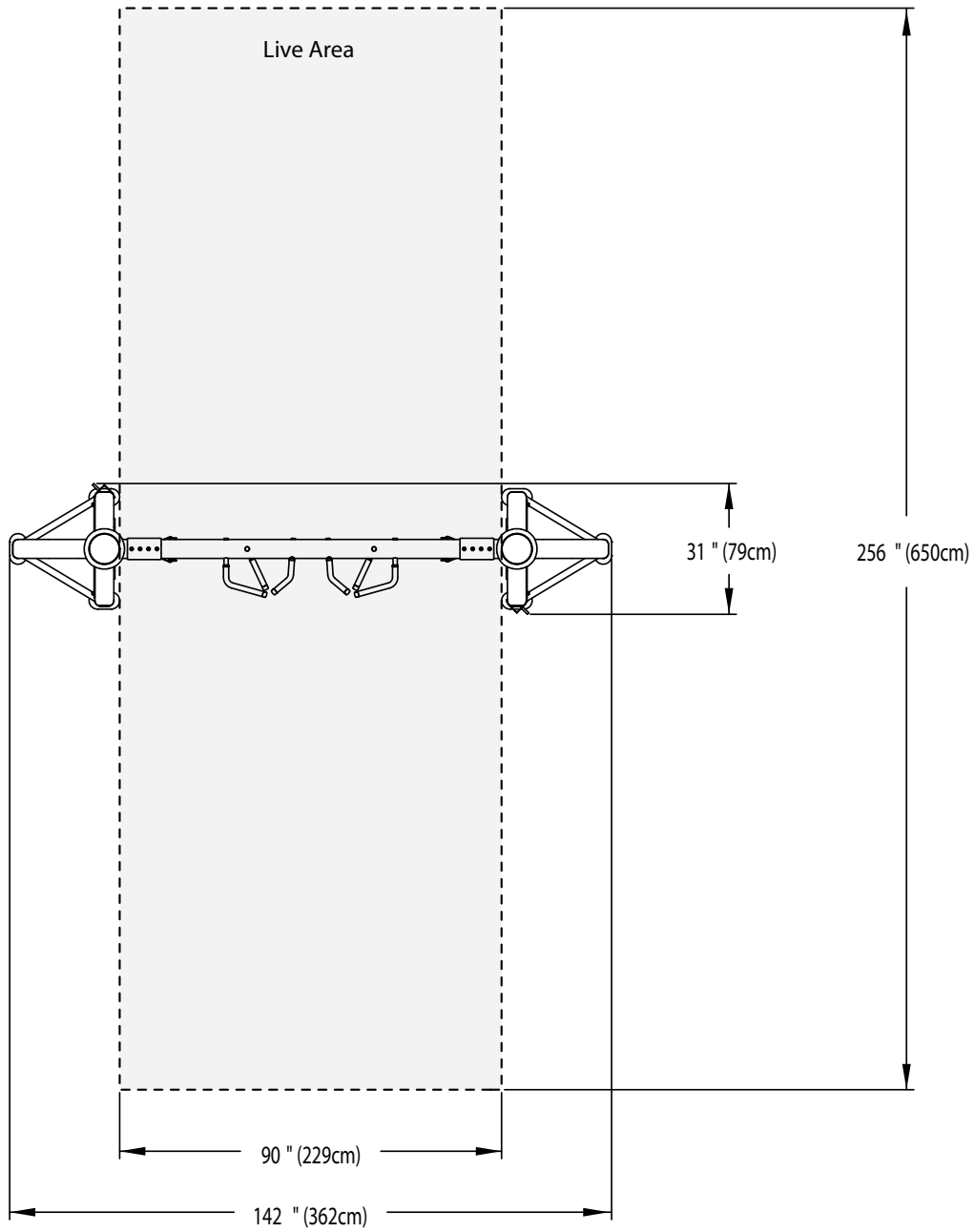

Size: in. = 142"L x 31"W x 94"H cm = 362cmL x 79cmW x 239cmH
Live Area: in. = 90"L x 256"W cm = 229cmL x 650cmW

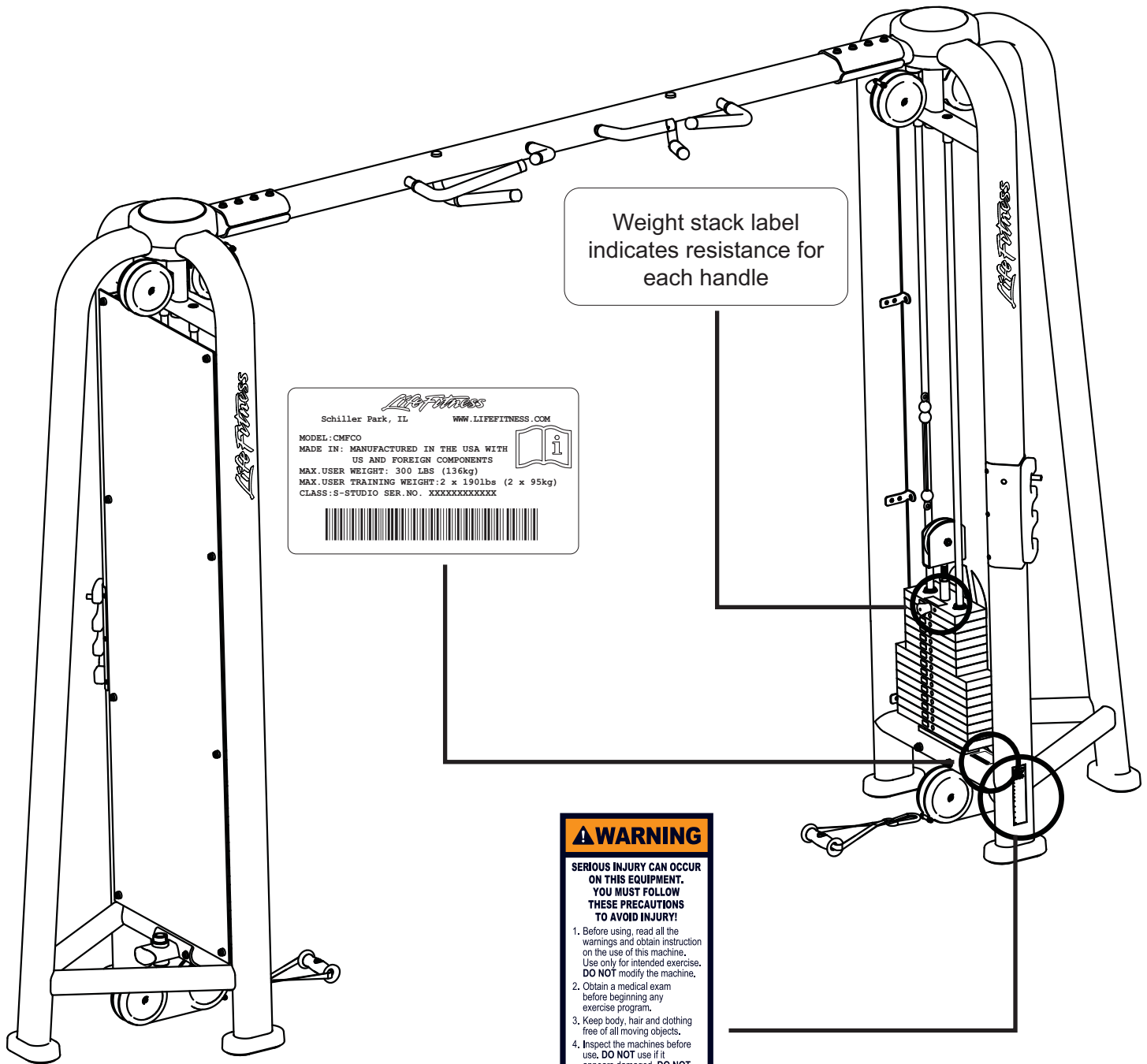

LABEL LOCATIONS (CMFCO)



Weight stack label indicates resistance for each handle



 Schiller Park, IL WWW.LIFEFITNESS.COM
 MODEL: CMFCO
 MADE IN: MANUFACTURED IN THE USA WITH
 US AND FOREIGN COMPONENTS
 MAX. USER WEIGHT: 300 LBS (136kg)
 MAX. USER TRAINING WEIGHT: 2 x 190lbs (2 x 95kg)
 CLASS: S-STUDIO SER. NO. XXXXXXXXXXXXX

⚠ WARNING

SERIOUS INJURY CAN OCCUR ON THIS EQUIPMENT. YOU MUST FOLLOW THESE PRECAUTIONS TO AVOID INJURY!

1. Before using, read all the warnings and obtain instruction on the use of this machine. Use only for intended exercise. **DO NOT** modify the machine.
2. Obtain a medical exam before beginning any exercise program.
3. Keep body, hair and clothing free of all moving objects.
4. Inspect the machines before use. **DO NOT** use if it appears damaged. **DO NOT** attempt to fix a broken or jammed machine. Notify staff immediately.
5. Be certain that weight pin is completely inserted. Use only the pin provided by the manufacturer. If unsure, seek assistance.
6. Never pin the weights or prop plate into an elevated position. **DO NOT** use the machine if found in this condition. **DO NOT** attempt to fix. Seek assistance.
7. Inspect cables and their connections before using machine. **DO NOT** attempt to fix. Seek assistance.
8. Use only the incremental weights supplied by the manufacturer. **DO NOT** use dumbbells or other means to add resistance to the machine.
9. Children must not be allowed near this machine. Supervise teenagers.
10. Manufacturer recommends that all equipment be secured to the floor to stabilize and eliminate rocking or tipping over. Use a licensed contractor.
11. **DO NOT REMOVE THIS LABEL. REPLACE IF DAMAGED.**

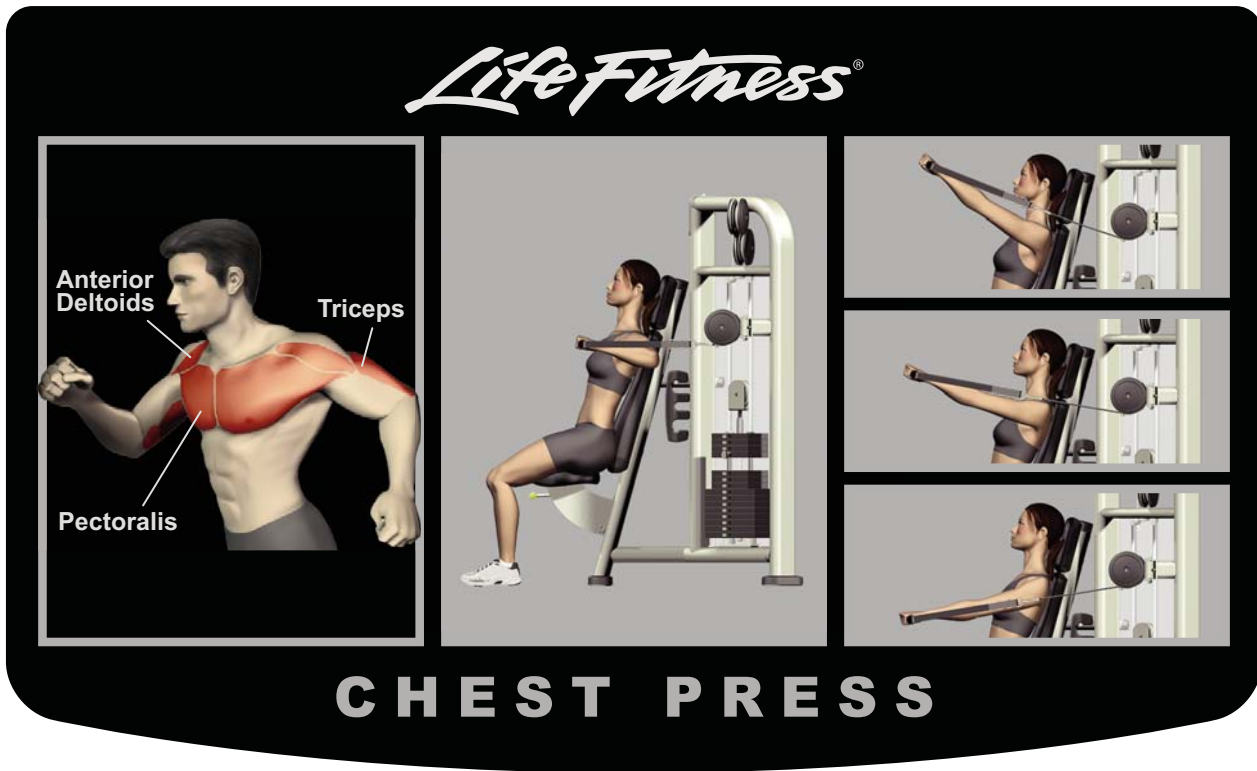
Cable Motion Chest Press (CMCP)



Muscles Exercised: Pectoralis Major, Anterior Deltoids and Triceps

Setup

Adjust the seat height so pulleys are aligned with mid-chest. Check the weight stacks to ensure proper resistance. Grip the handles and position elbows slightly below shoulders. Body is positioned with chest up, shoulders and head back against the back pad.

Performing the Exercise

With a controlled motion, extend the handles out until the arms are fully extended. Return the handles to the start position, without letting the resistance rest on the stack. Repeat the motion while maintaining proper body position.

TIP: While performing the exercise, choose varying incline and decline pressing angles to maximize stimulation of the Pectoralis and Anterior Deltoid.

Product Code - CMCP

Machine Weight:	673 lbs	305 kg
Max User Weight:	300 lbs	136 kg
Resistance Ratio:	1:2	
Weight Stack:	2 x 190 lbs	2 x 95 kg
Effective User Resistance:	2 x 95 lbs	2 x 47.50 kg

PRODUCT DIMENSIONS WITH WORKING AREA (CMCP)

Size: in. = 46"L x 48"W x 64"H cm = 117cmL x 123cmW x 162cmH
Live Area: in. = 70"L x 84"W cm = 178cmL x 214cmW

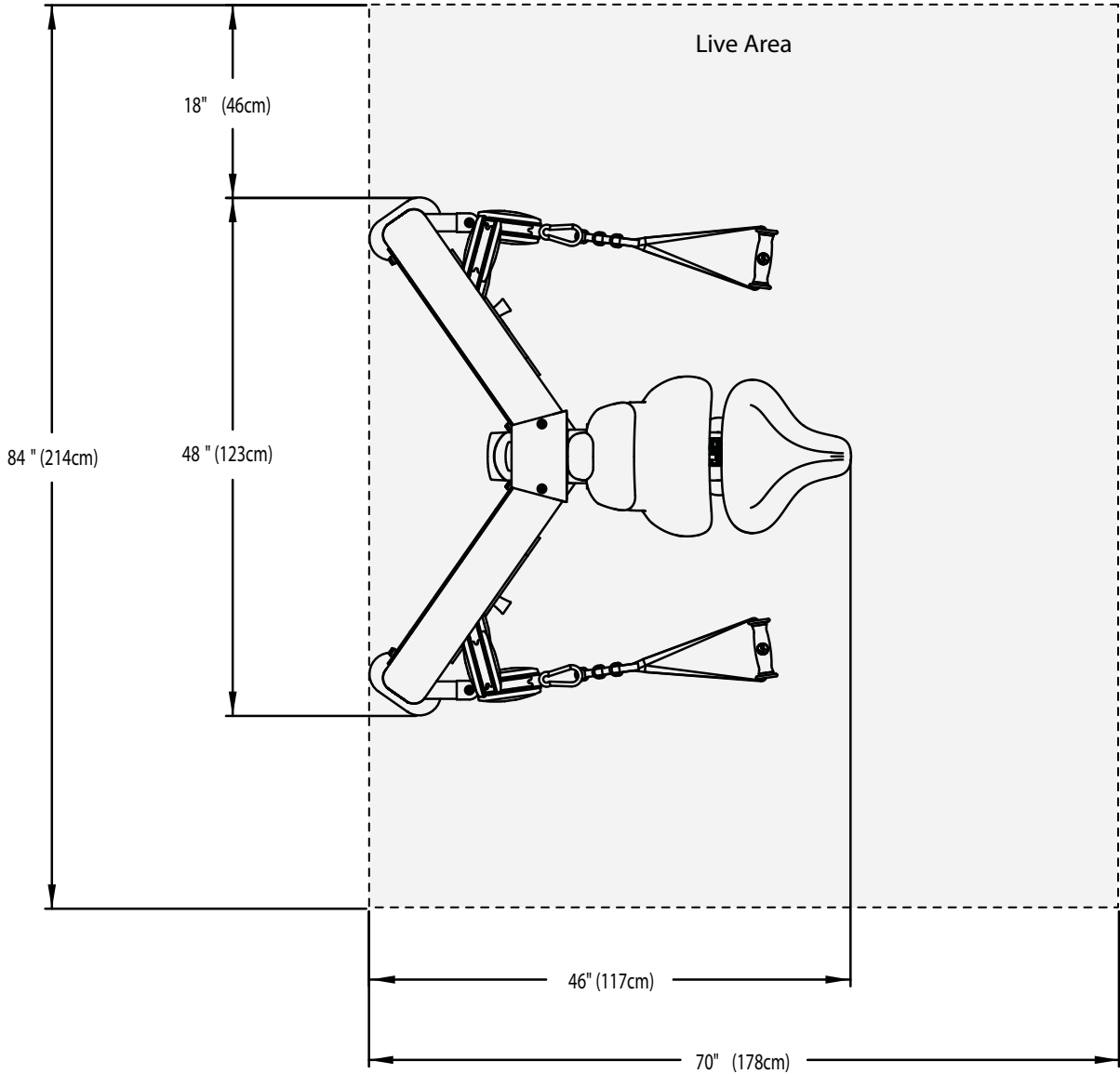

LABEL LOCATIONS (CMCP)

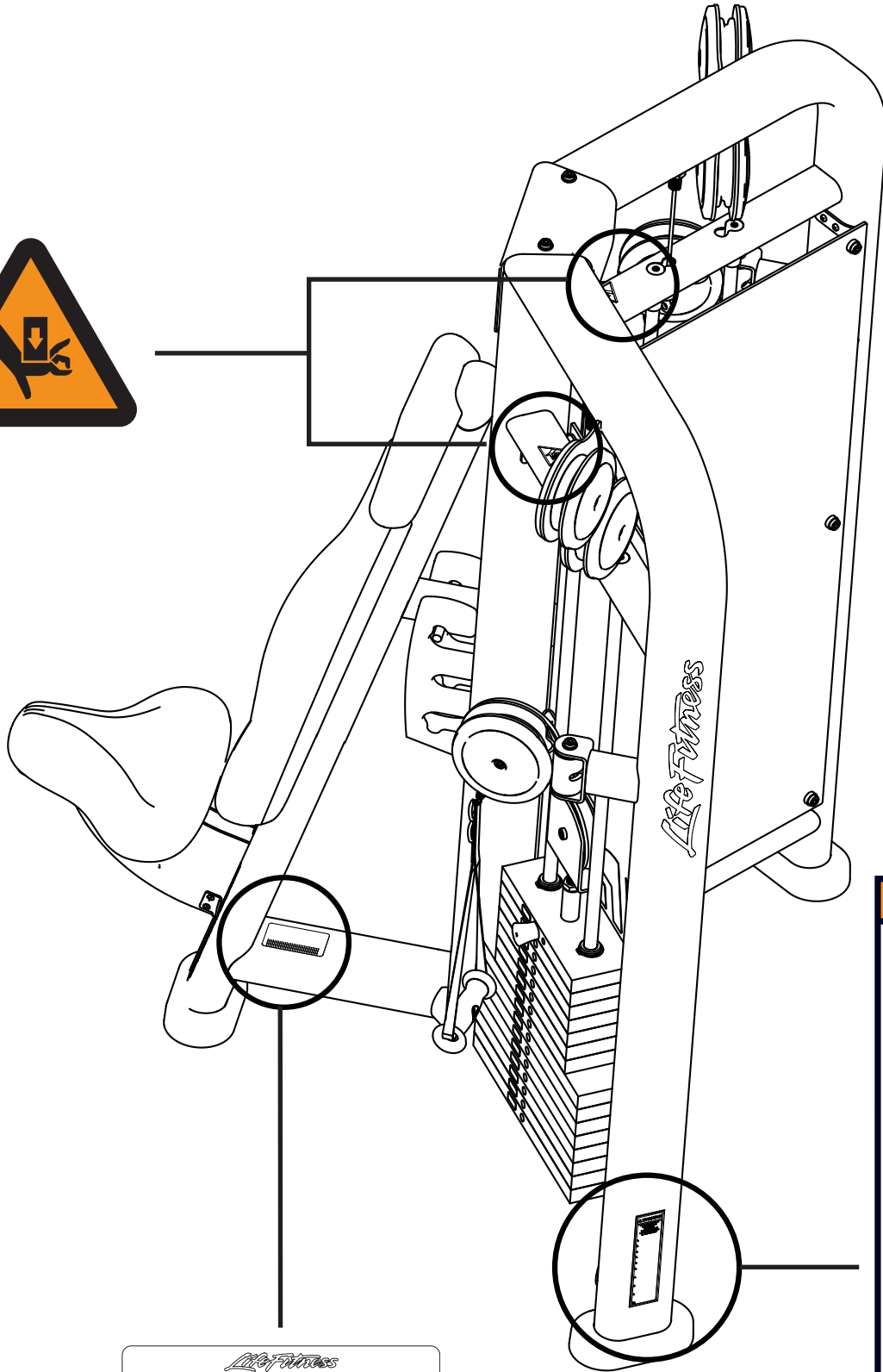

Life Fitness
Schiller Park, IL WWW.LIFEFITNESS.COM

MODEL: CMCP
MADE IN: MANUFACTURED IN THE USA WITH
US AND FOREIGN COMPONENTS

MAX USER WEIGHT: 300 LBS (136kg)
MAX USER TRAINING WEIGHT: 2 x 190lbs (2 x 95kg)
CLASS: S-STUDIO SER.NO. XXXXXXXXXXXXX



WARNING

SERIOUS INJURY CAN OCCUR ON THIS EQUIPMENT. YOU MUST FOLLOW THESE PRECAUTIONS TO AVOID INJURY!

1. Before using, read all the warnings and obtain instruction on the use of this machine. Use only for intended exercise. **DO NOT** modify the machine.
2. Obtain a medical exam before beginning any exercise program.
3. Keep body, hair and clothing free of all moving objects.
4. Inspect the machines before use. **DO NOT** use if it appears damaged. **DO NOT** attempt to fix a broken or jammed machine. Notify staff immediately.
5. Be certain that weight pin is completely inserted. Use only the pin provided by the manufacturer. If unsure, seek assistance.
6. Never pin the weights or prop plate into an elevated position. **DO NOT** use the machine if found in this condition. **DO NOT** attempt to fix. Seek assistance.
7. Inspect cables and their connections before using machine. **DO NOT** attempt to fix. Seek assistance.
8. Use only the incremental weights supplied by the manufacturer. **DO NOT** use dumbbells or other means to add resistance to the machine.
9. Children must not be allowed near this machine. Supervise teenagers.
10. Manufacturer recommends that all equipment be secured to the floor to stabilize and eliminate rocking or tipping over. Use a licensed contractor.
11. **DO NOT REMOVE THIS LABEL. REPLACE IF DAMAGED.**

Cable Motion Shoulder Press (CMSP)

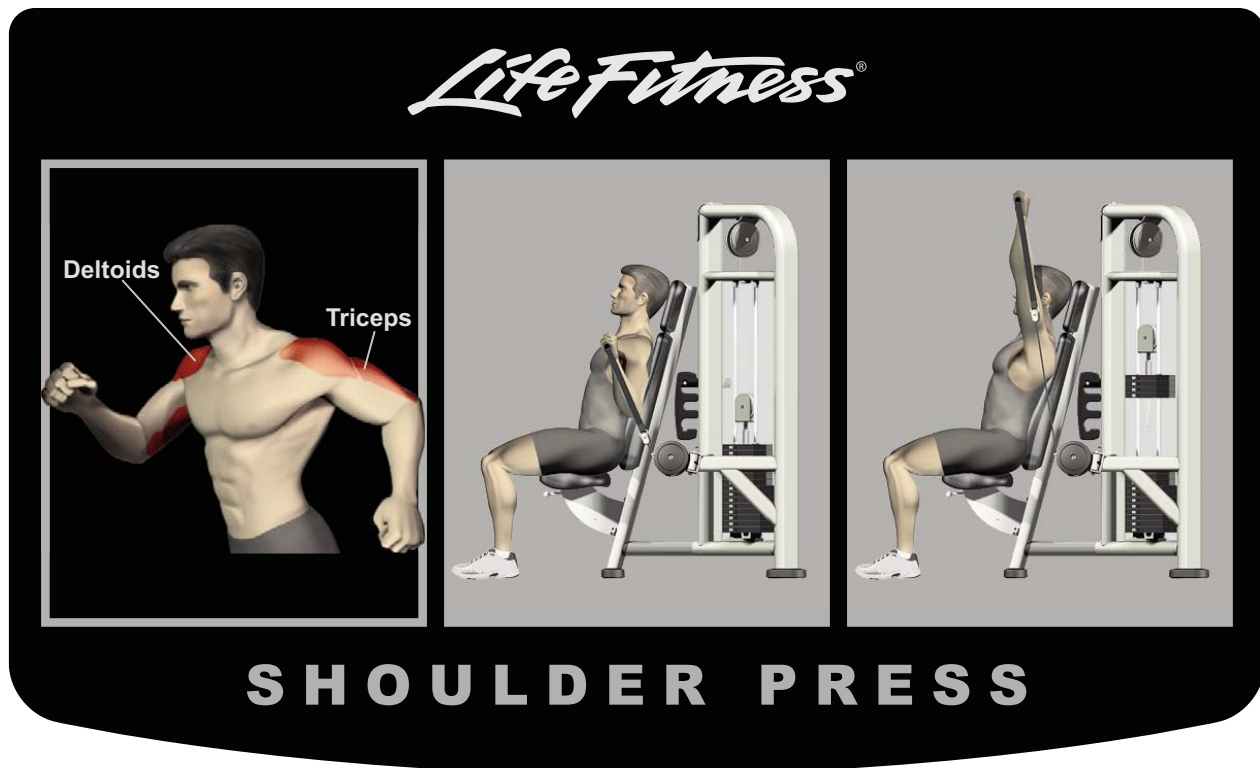

Muscles Exercised: Deltoids and Triceps

Setup

Adjust the seat height so handles are aligned with or above shoulder height. Check the weight stacks to ensure appropriate resistance. Grip one or both handles. Body is positioned with chest-up, shoulders and head back against back pad.

Performing the Exercise

With a controlled motion, extend the handles up until arms are fully extended. Return the handles to the start position, without letting the resistance rest on the stack. Repeat the motion, while maintaining proper body positioning.

TIP: Focus on extending your elbows as opposed to pressing the handles up, as this increases the mental concentration on the Deltoid muscles.

Product Code - CMSP

Machine Weight:	599 lbs	272 kg
Max User Weight:	300 lbs	136 kg
Resistance Ratio:	1:2	
Weight Stack:	2 x 150 lbs	2 x 75 kg
Effective User Resistance:	2 x 75 lbs	2 x 37.5 kg

PRODUCT DIMENSIONS WITH WORKING AREA (CMSP)

Size: in. = 46"L x 48"W x 64"H cm = 117cmL x 123cmW x 162cmH
Live Area: in. = 46"L x 84"W cm = 117cmL x 214cmW

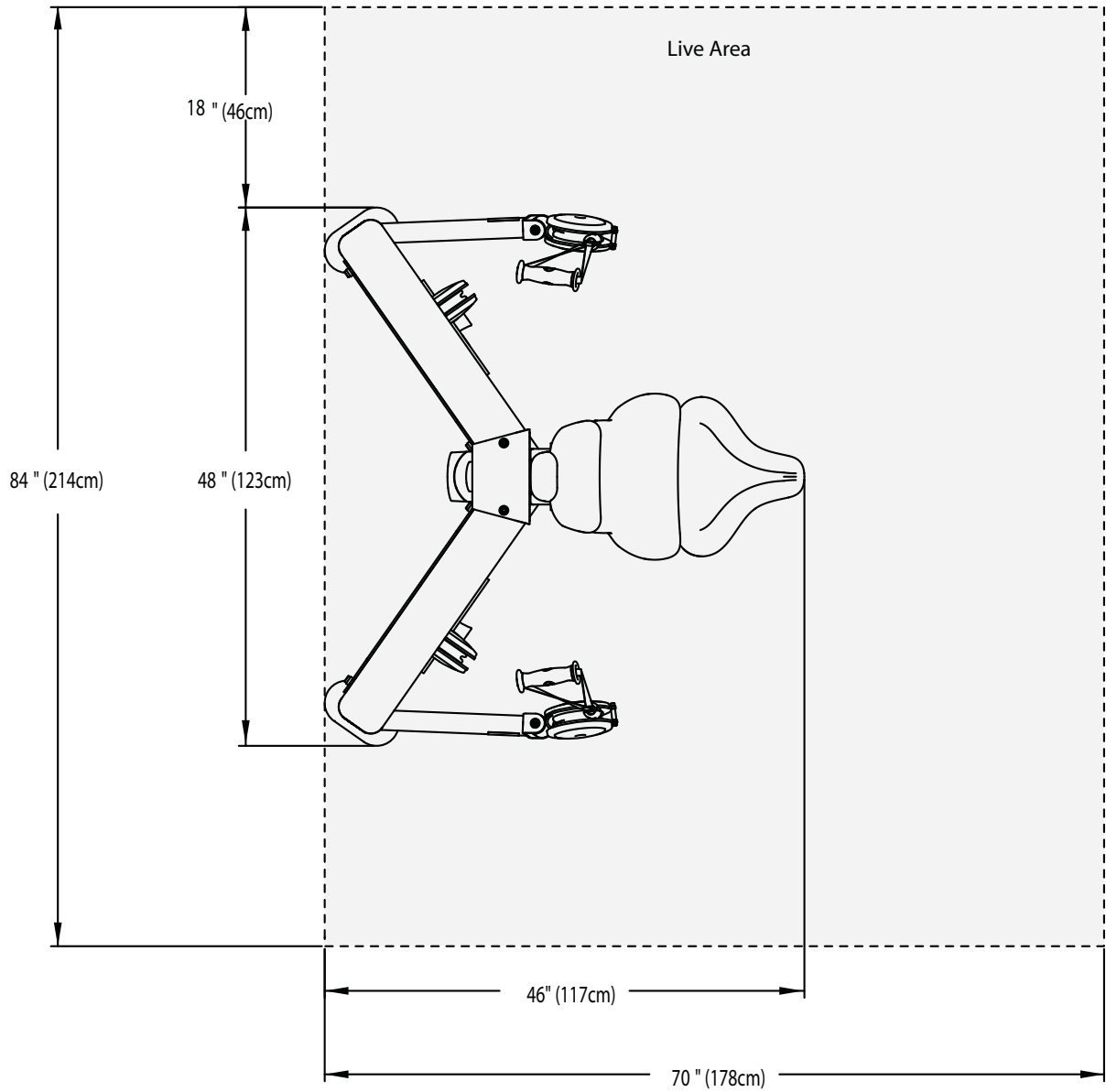

LABEL LOCATIONS (CMSP)

Life Fitness
Schiller Park, IL WWW.LIFEFITNESS.COM

MODEL: CMSP
MADE IN: MANUFACTURED IN THE USA WITH
US AND FOREIGN COMPONENTS 
MAX. USER WEIGHT: 300 LBS (136kg)
MAX. USER TRAINING WEIGHT: 2 x 150lbs (2 x 75kg)
CLASS: S-STUDIO SER. NO. XXXXXXXXXXXXX





⚠ WARNING

SERIOUS INJURY CAN OCCUR ON THIS EQUIPMENT. YOU MUST FOLLOW THESE PRECAUTIONS TO AVOID INJURY!

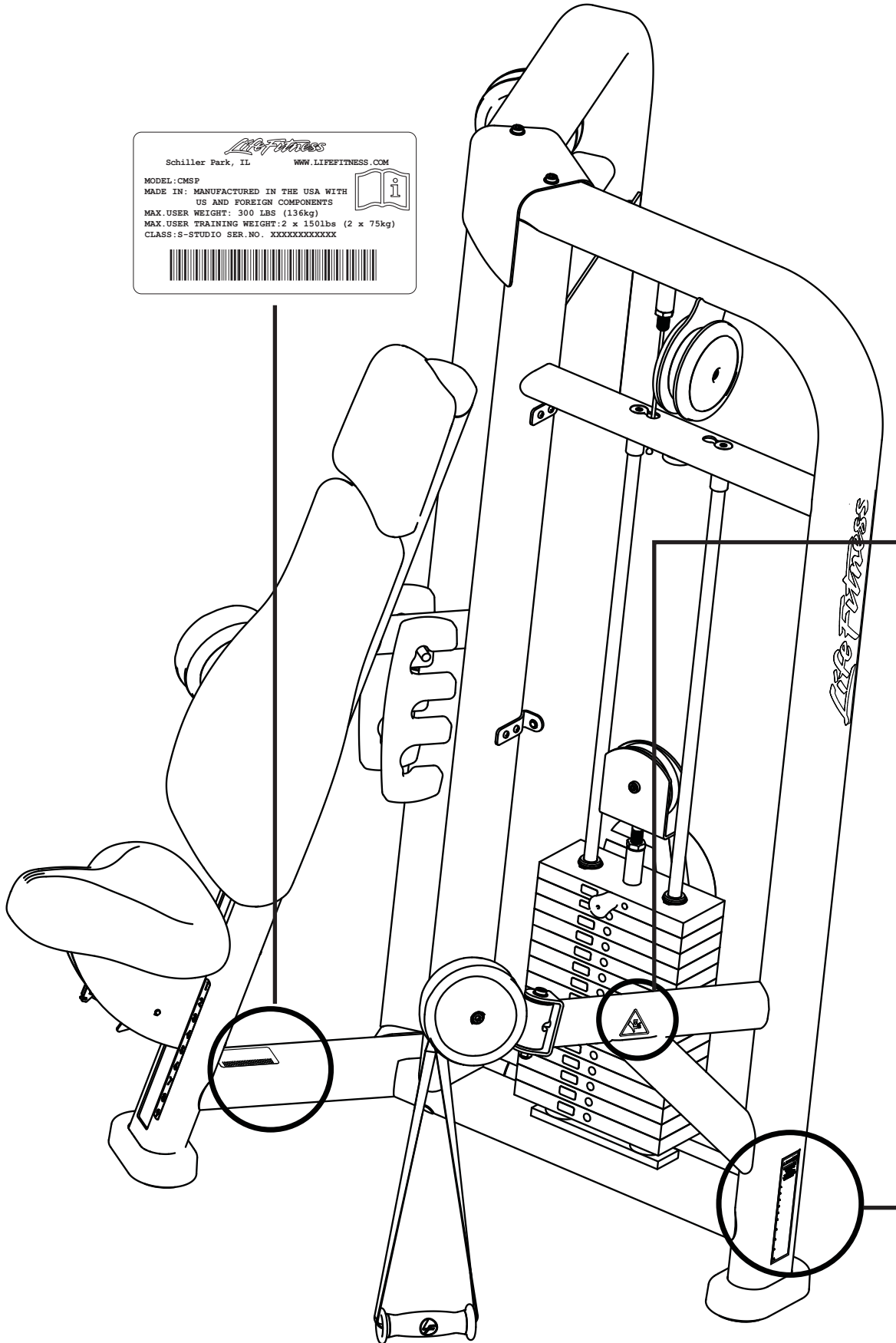
1. Before using, read all the warnings and obtain instruction on the use of this machine. Use only for intended exercise. **DO NOT** modify the machine.
2. Obtain a medical exam before beginning any exercise program.
3. Keep body, hair and clothing free of all moving objects.
4. Inspect the machines before use. **DO NOT** use if it appears damaged. **DO NOT** attempt to fix a broken or jammed machine. Notify staff immediately.
5. Be certain that weight pin is completely inserted. Use only the pin provided by the manufacturer. If unsure, seek assistance.
6. Never pin the weights or prop plate into an elevated position. **DO NOT** use the machine if found in this condition. **DO NOT** attempt to fix. Seek assistance.
7. Inspect cables and their connections before using machine. **DO NOT** attempt to fix. Seek assistance.
8. Use only the incremental weights supplied by the manufacturer. **DO NOT** use dumbbells or other means to add resistance to the machine.
9. Children must not be allowed near this machine. Supervise teenagers.
10. Manufacturer recommends that all equipment be secured to the floor to stabilize and eliminate rocking or tipping over. Use a licensed contractor.
11. **DO NOT REMOVE THIS LABEL. REPLACE IF DAMAGED.**

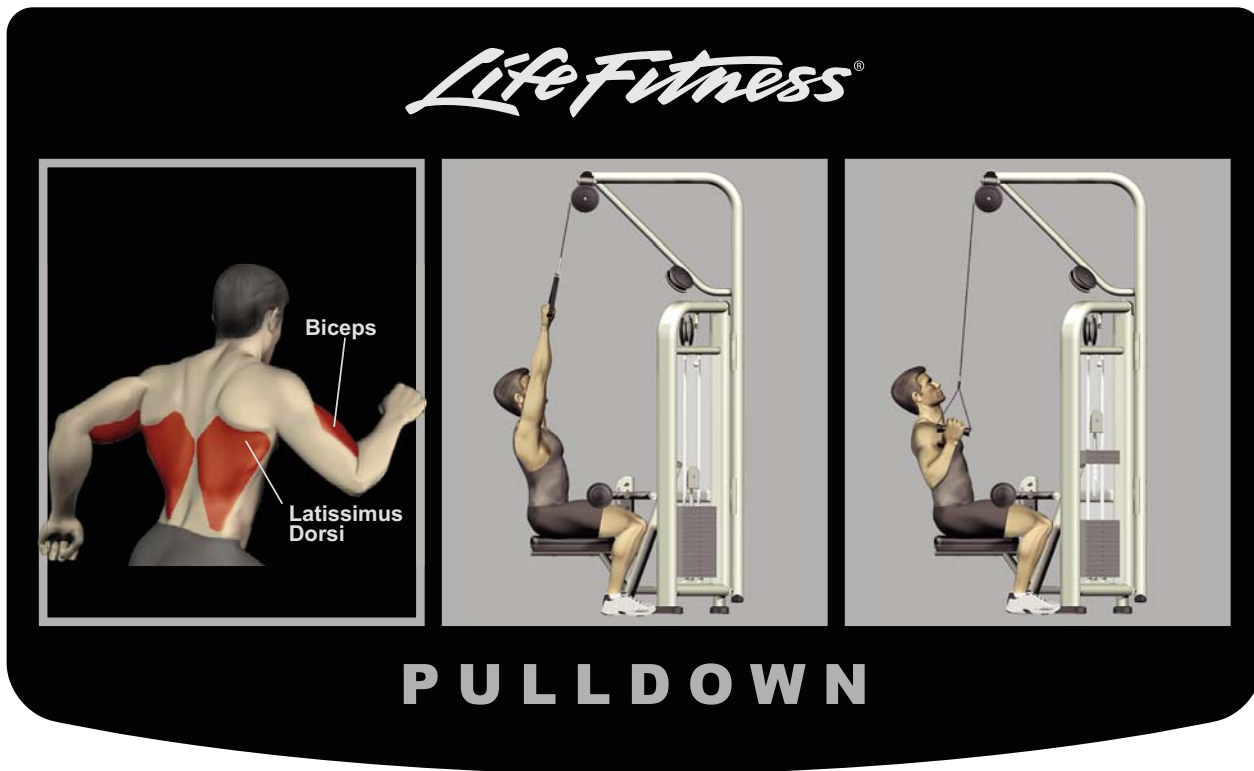

Cable Motion Pulldown (CMPD)



Muscles Exercised: Latissimus Dorsi and Biceps

Setup

Check the weight stacks to ensure appropriate resistance. Stand and grip handles, then pull down and sit with thighs under pads. Upper body is positioned leaning slightly back from the hips, pulling directly over shoulders.

TIP: Attempt to stabilize the body without the use of the thigh pads until necessary.

Performing the Exercise

With a controlled motion, draw down the handles directly over the shoulders until hands reach shoulder height, then extend the handles up until arms are fully extended. Return the handles to the start position and repeat the motion, while maintaining proper body positioning.

TIP: While performing the exercise think about lowering your elbows towards your lower back. This will re-enforce the correct exercise position and increases the mental concentration on the Latissimus Dorsi.

Product Code - CMPD

Machine Weight:	829 lbs	376 kg
Max User Weight:	300 lbs	136 kg
Resistance Ratio:	1:2	
Weight Stack:	2 x 220 lbs	2 x 107 kg
Effective User Resistance:	2 x 110 lbs	2 x 53.5 kg

PRODUCT DIMENSIONS WITH WORKING AREA (CMPD)

Size: in. = 47"L x 54"W x 94"H cm = 119cmL x 136cmW x 240cmH

Live Area: in. = 71"L x 90"W cm = 180cmL x 228cmW

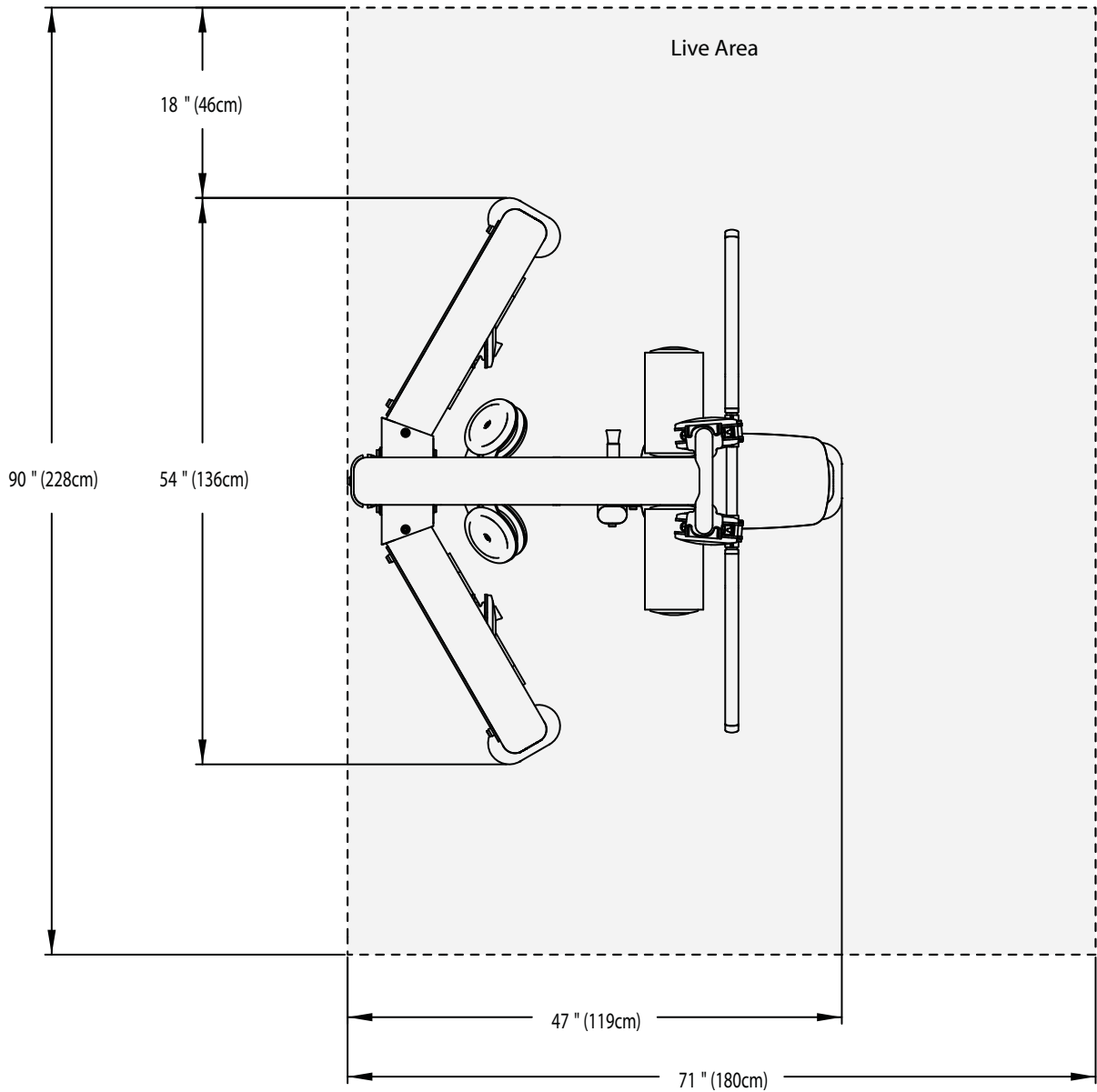

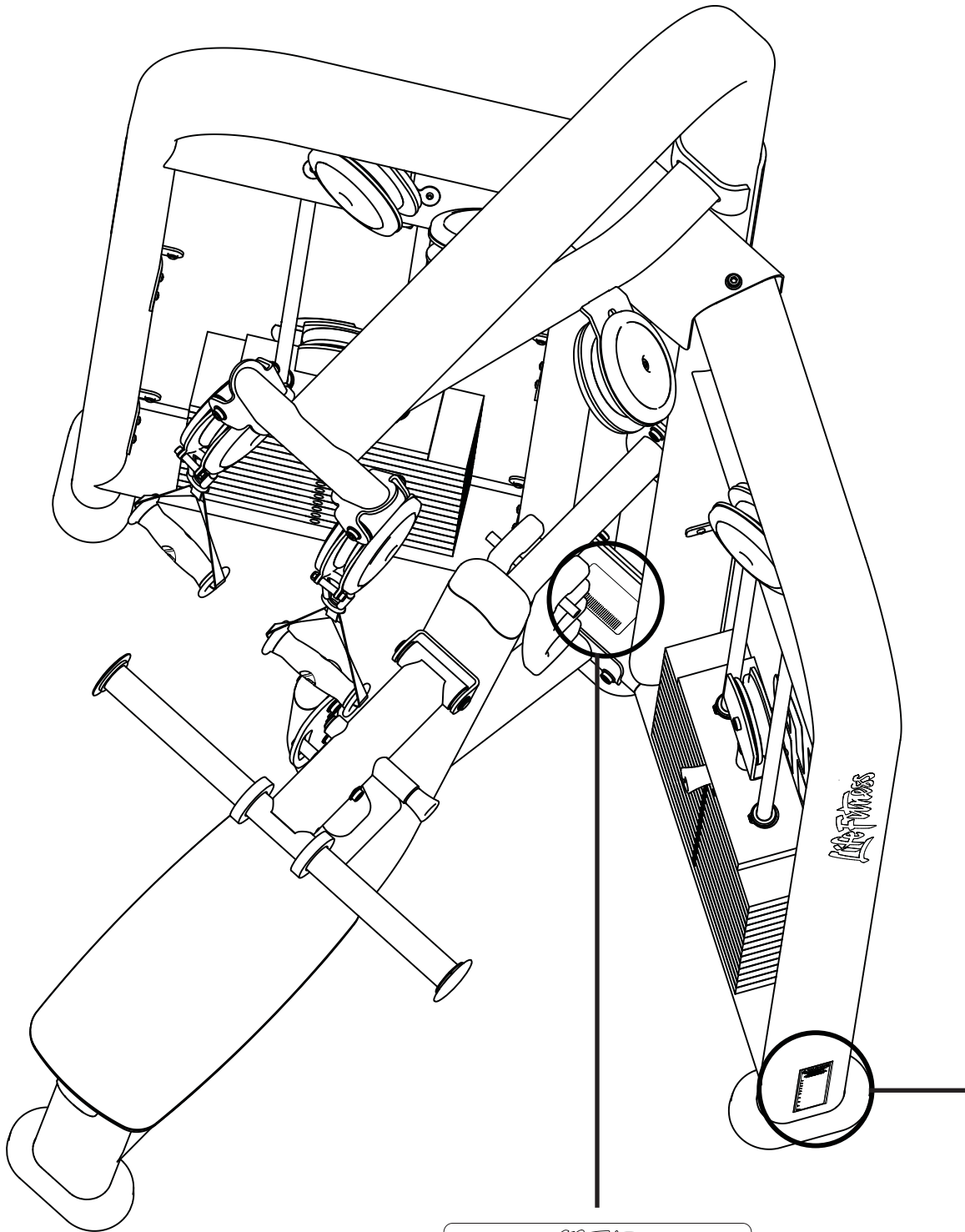

LABEL LOCATIONS (CMPD)



Life Fitness
Schiller Park, IL WWW.LIFEFITNESS.COM

MODEL: CMPD
MADE IN: MANUFACTURED IN THE USA WITH
US AND FOREIGN COMPONENTS
MAX. USER WEIGHT: 300 LBS (136kg)
MAX. USER TRAINING WEIGHT: 2 x 220lbs (2 x 107kg)
CLASS: S-STUDIO SER. NO. XXXXXXXXXXXXX





WARNING

SERIOUS INJURY CAN OCCUR ON THIS EQUIPMENT. YOU MUST FOLLOW THESE PRECAUTIONS TO AVOID INJURY!

1. Before using, read all the warnings and obtain instruction on the use of this machine. Use only for intended exercise. **DO NOT** modify the machine.
2. Obtain a medical exam before beginning any exercise program.
3. Keep body, hair and clothing free of all moving objects.
4. Inspect the machines before use. **DO NOT** use if it appears damaged. **DO NOT** attempt to fix a broken or jammed machine. Notify staff immediately.
5. Be certain that weight pin is completely inserted. Use only the pin provided by the manufacturer. If unsure, seek assistance.
6. Never pin the weights or prop plate into an elevated position. **DO NOT** use the machine if found in this condition. **DO NOT** attempt to fix. Seek assistance.
7. Inspect cables and their connections before using machine. **DO NOT** attempt to fix. Seek assistance.
8. Use only the incremental weights supplied by the manufacturer. **DO NOT** use dumbbells or other means to add resistance to the machine.
9. Children must not be allowed near this machine. Supervise teenagers.
10. Manufacturer recommends that all equipment be secured to the floor to stabilize and eliminate rocking or tipping over. Use a licensed contractor.
11. **DO NOT REMOVE THIS LABEL. REPLACE IF DAMAGED.**

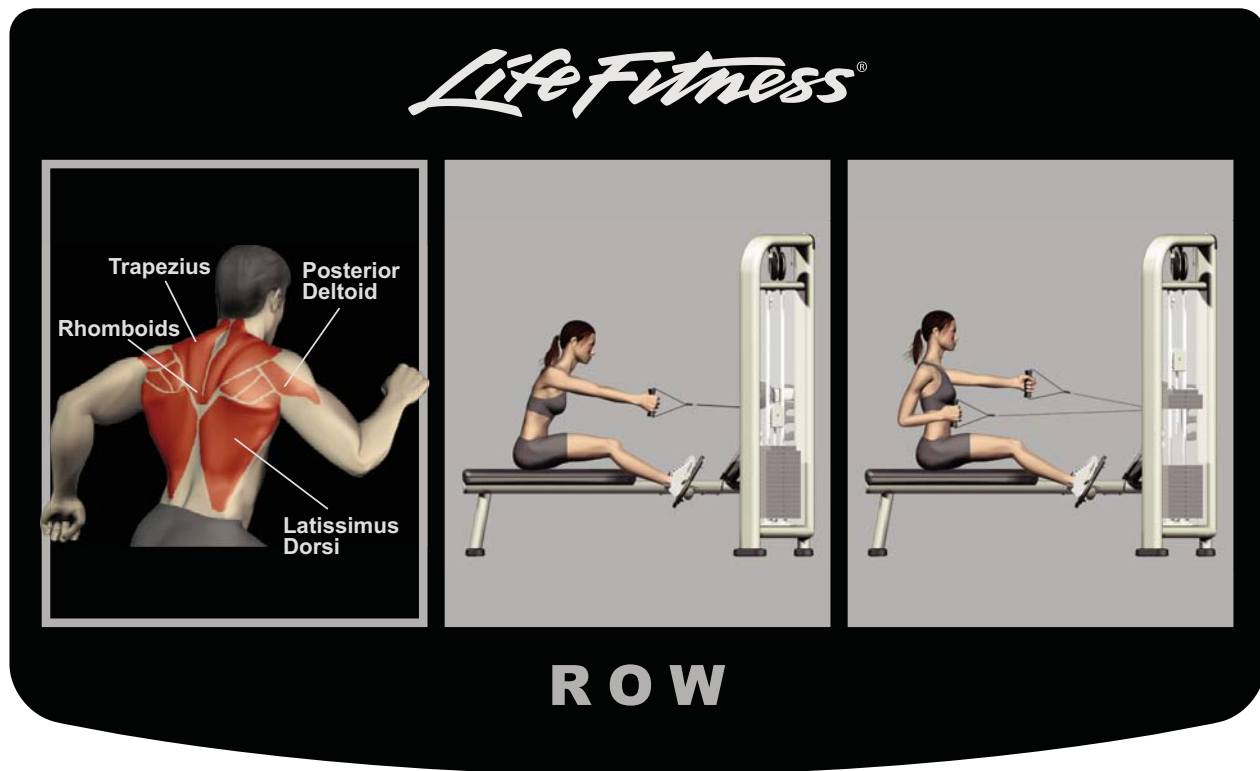
Cable Motion Row (CMRW)



Muscles Exercised: Latissimus Dorsi, Trapezius, Rhomboids, Teres Major and Minor, Posterior Deltoids & Biceps

Setup

Check the weight stack to ensure appropriate resistance. Grip the handles and position body with feet on the platform and head and chest-up.

Performing the Exercise

Stabilize the body in position, pressing feet firmly on foot platform. Stabilize upper body by drawing in abdominals. With a controlled motion, draw back the arms as far as can be controlled. Return the handles to the start position, without letting the resistance rest on the stack. Repeat the motion, while maintaining proper body positioning.

TIP: While performing the exercise, think about drawing the elbows back beyond the body and stabilizing the upper body as this increases the mental concentration on the muscles being trained.

Product Code - CMRW

Machine Weight:	779 lbs	354 kg
Max User Weight:	300 lbs	136 kg
Resistance Ratio:	1:2	
Weight Stack:	2 x 220 lbs	2 x 107 kg
Effective User Resistance:	2 x 110 lbs	2 x 53.5 kg

PRODUCT DIMENSIONS WITH WORKING AREA (CMRW)

Size: in. = 73"L x 54"W x 67"H cm = 186cmL x 136cmW x 170cmH

Live Area: in. = 97"L x 90"W cm = 247cmL x 228cmW

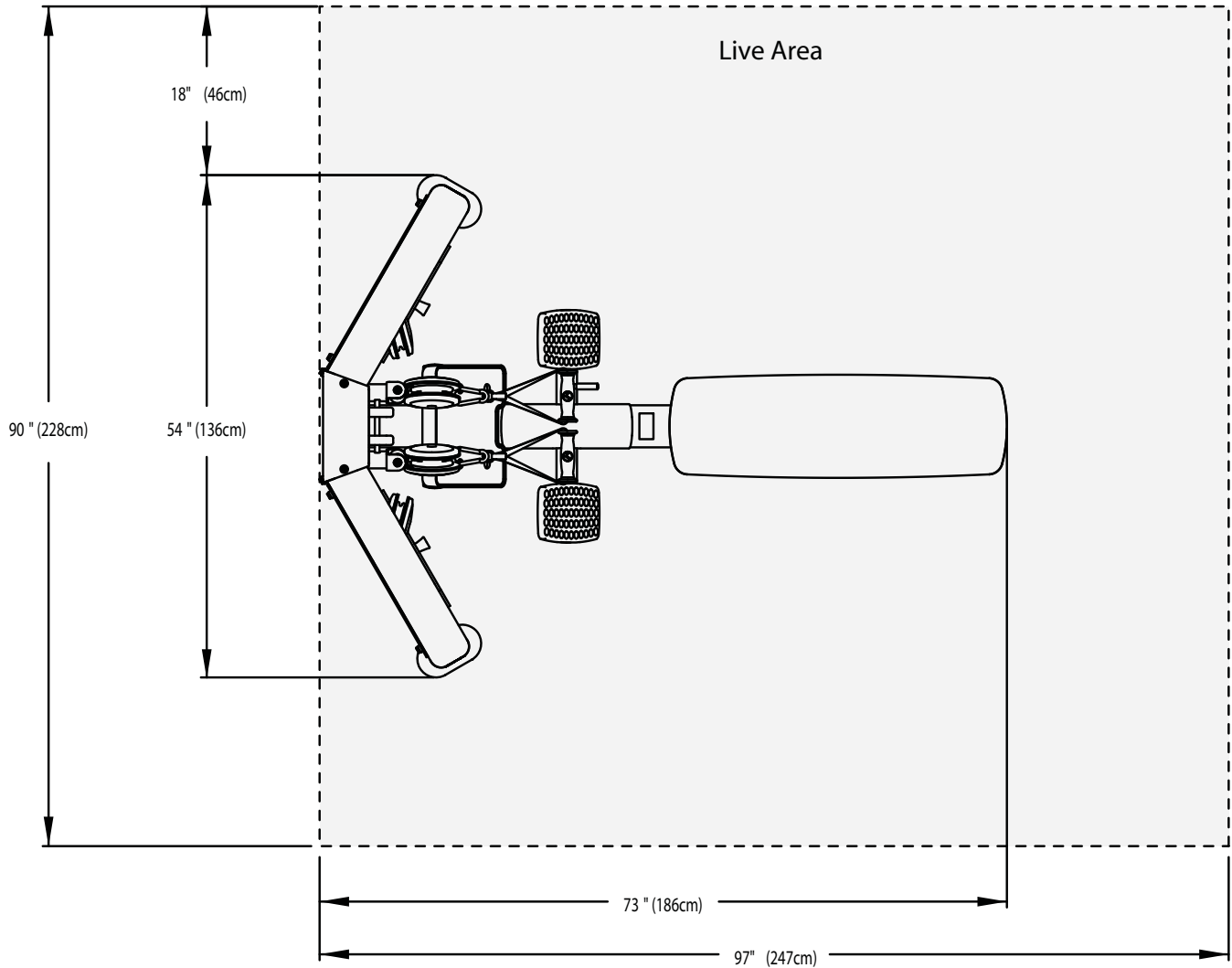

LABEL LOCATIONS (CMRW)

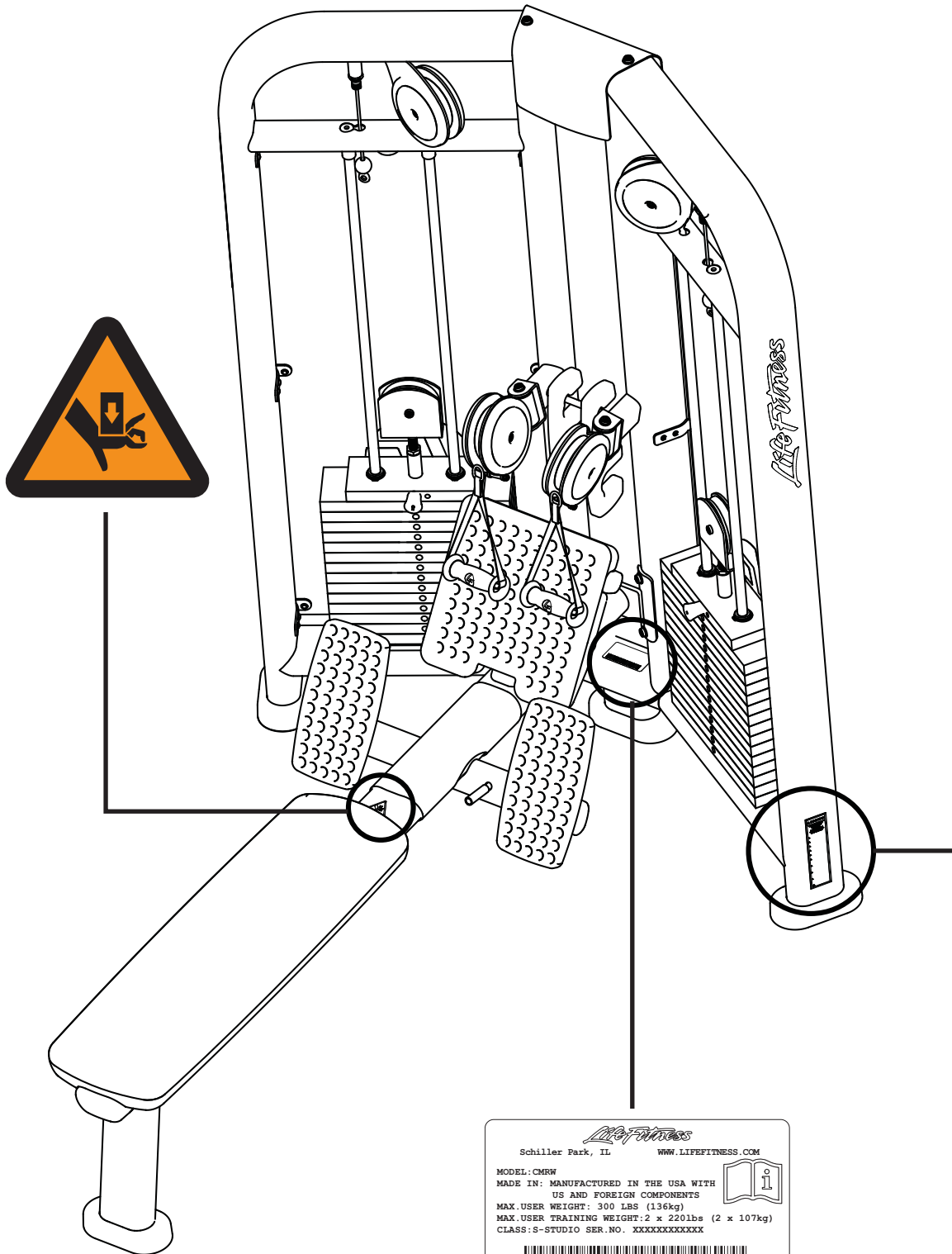

Life Fitness
 Schiller Park, IL WWW.LIFFITNESS.COM

MODEL: CMRW
 MADE IN: MANUFACTURED IN THE USA WITH
 US AND FOREIGN COMPONENTS
 MAX. USER WEIGHT: 300 LBS (136kg)
 MAX. USER TRAINING WEIGHT: 2 x 220lbs (2 x 107kg)
 CLASS: S-STUDIO SER. NO. XXXXXXXXXXXXX



⚠ WARNING

SERIOUS INJURY CAN OCCUR ON THIS EQUIPMENT. YOU MUST FOLLOW THESE PRECAUTIONS TO AVOID INJURY!

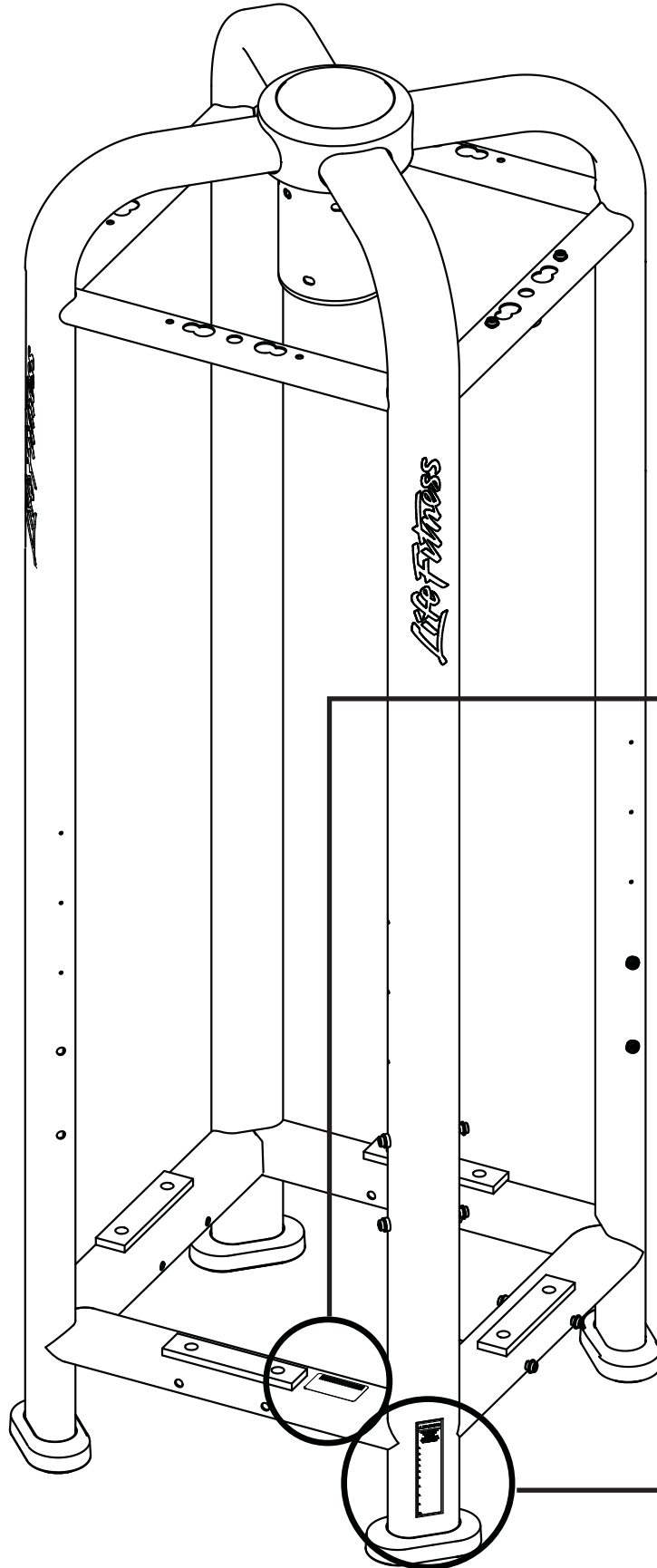

1. Before using, read all the warnings and obtain instruction on the use of this machine. Use only for intended exercise. **DO NOT** modify the machine.
2. Obtain a medical exam before beginning any exercise program.
3. Keep body, hair and clothing free of all moving objects.
4. Inspect the machines before use. **DO NOT** use if it appears damaged. **DO NOT** attempt to fix a broken or jammed machine. Notify staff immediately.
5. Be certain that weight pin is completely inserted. Use only the pin provided by the manufacturer. If unsure, seek assistance.
6. Never pin the weights or prop plate into an elevated position. **DO NOT** use the machine if found in this condition. **DO NOT** attempt to fix. Seek assistance.
7. Inspect cables and their connections before using machine. **DO NOT** attempt to fix. Seek assistance.
8. Use only the incremental weights supplied by the manufacturer. **DO NOT** use dumbbells or other means to add resistance to the machine.
9. Children must not be allowed near this machine. Supervise teenagers.
10. Manufacturer recommends that all equipment be secured to the floor to stabilize and eliminate rocking or tipping over. Use a licensed contractor.
11. **DO NOT REMOVE THIS LABEL. REPLACE IF DAMAGED.**

MULTI JUNGLE CORE TOWER LABEL LOCATIONS



Life Fitness
Schiller Park, IL WWW.LIFEFITNESS.COM

MODEL: MJXX
MADE IN: MANUFACTURED IN THE USA WITH
US AND FOREIGN COMPONENTS
MAX. USER WEIGHT: xxx LBS (xxkg)
MAX. USER TRAINING WEIGHT: xx1bs (xxkg)
CLASS: S-STUDIO SER. NO. XXXXXXXXXXXX

⚠ WARNING

SERIOUS INJURY CAN OCCUR ON THIS EQUIPMENT. YOU MUST FOLLOW THESE PRECAUTIONS TO AVOID INJURY!

1. Before using, read all the warnings and obtain instruction on the use of this machine. Use only for intended exercise. **DO NOT** modify the machine.
2. Obtain a medical exam before beginning any exercise program.
3. Keep body, hair and clothing free of all moving objects.
4. Inspect the machines before use. **DO NOT** use if it appears damaged. **DO NOT** attempt to fix a broken or jammed machine. Notify staff immediately.
5. Be certain that weight pin is completely inserted. Use only the pin provided by the manufacturer. If unsure, seek assistance.
6. Never pin the weights or prop plate into an elevated position. **DO NOT** use the machine if found in this condition. **DO NOT** attempt to fix. Seek assistance.
7. Inspect cables and their connections before using machine. **DO NOT** attempt to fix. Seek assistance.
8. Use only the incremental weights supplied by the manufacturer. **DO NOT** use dumbbells or other means to add resistance to the machine.
9. Children must not be allowed near this machine. Supervise teenagers.
10. Manufacturer recommends that all equipment be secured to the floor to stabilize and eliminate rocking or tipping over. Use a licensed contractor.
11. **DO NOT REMOVE THIS LABEL. REPLACE IF DAMAGED.**

Multi Jungle Adjustable Pulley (MJAP)



EXERCISE AND SETUP:

For a complete list of exercises and how to perform them please see exercise section 5-A.

Product Code - MJAP

Max User Weight:	300 lbs	136 kg
Resistance Ratio:	1:2	
Weight Stack:	190 lbs	95 kg
Effective User Resistance:	2 x 95 lbs	2 x 47.5 kg

PRODUCT DIMENSIONS WITH WORKING AREA (MJAP)

Size: in. = 51"L x 33"W x 94"H cm = 128cmL x 84cmW x 239cmH

Live Area: in. = 179"L x 268"W cm = 456cmL x 680cmW

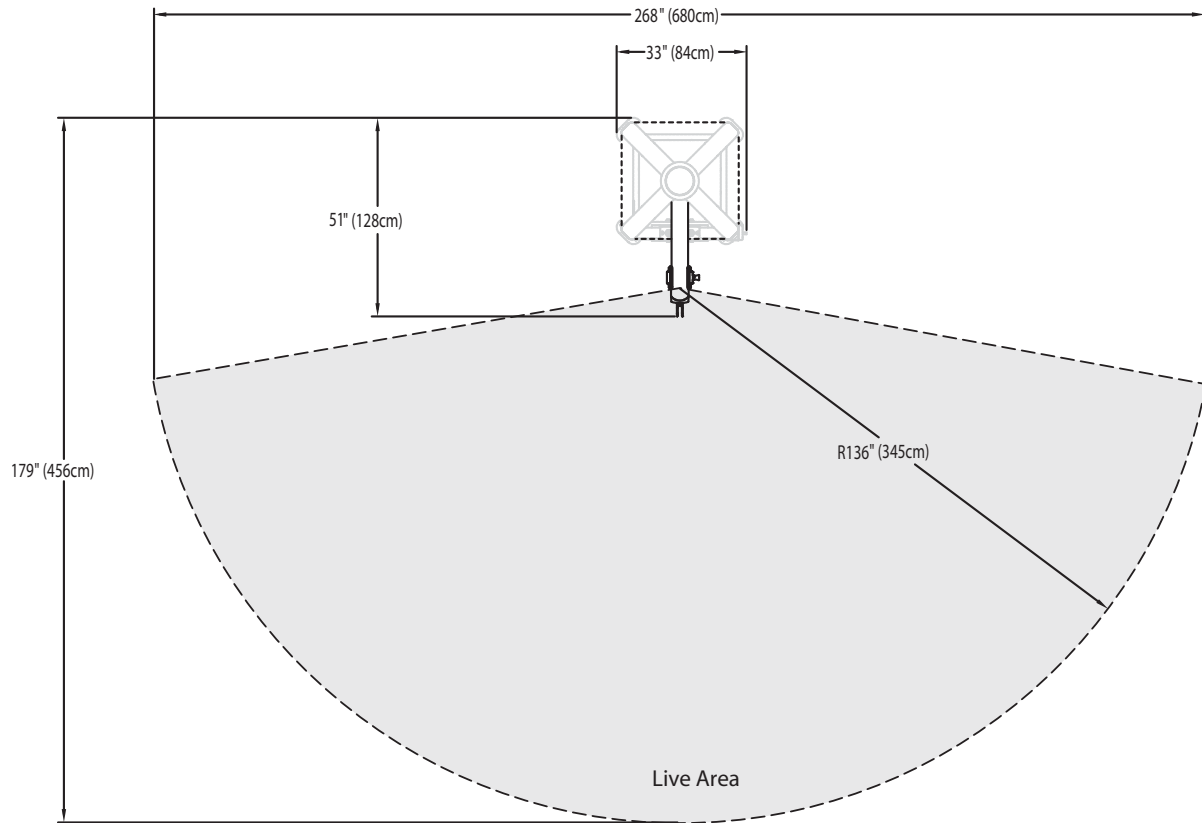

LABEL LOCATIONS (MJAP)

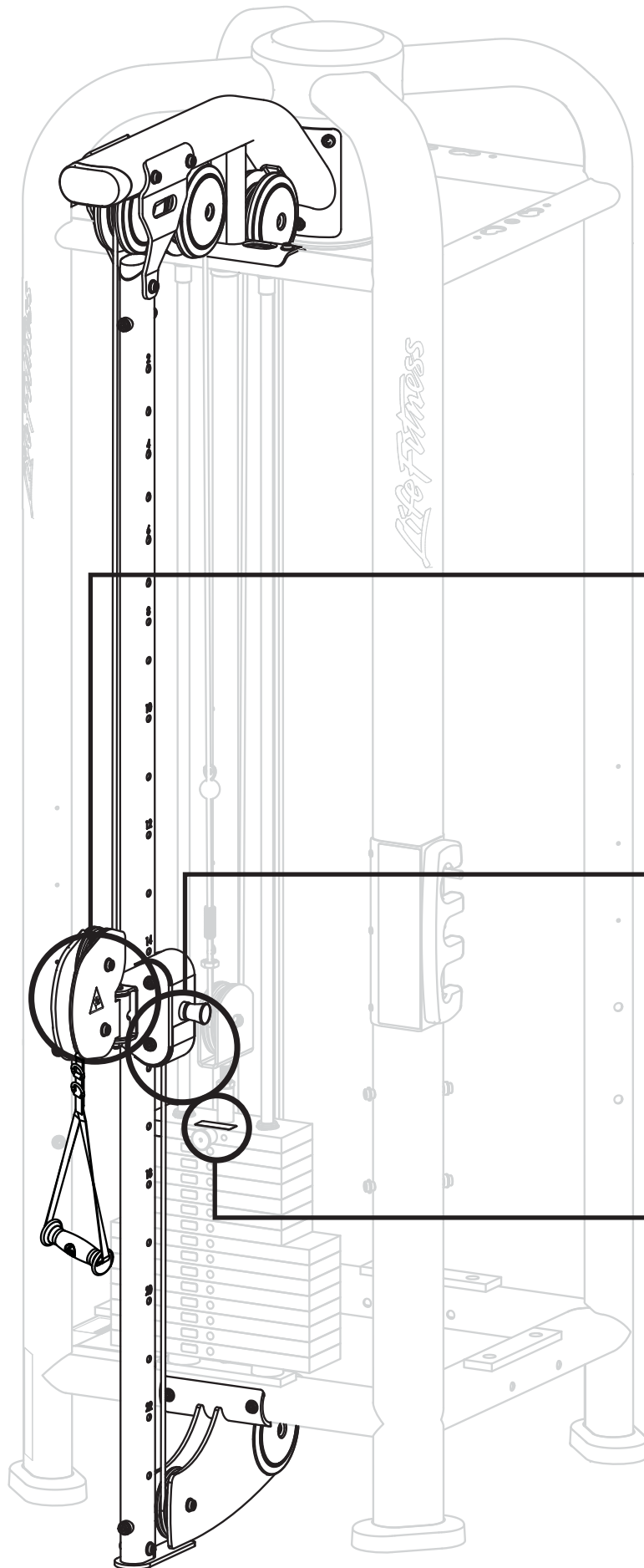

⚠ WARNING

Carriage Will Fall If Pull-pin Is Not Fully Engaged.



Ensure Full Engagement As Illustrated Here To Avoid Injury.

Weight stack label indicates resistance for each handle

Multi Jungle Adjustable Cable Crossover (MJACO)

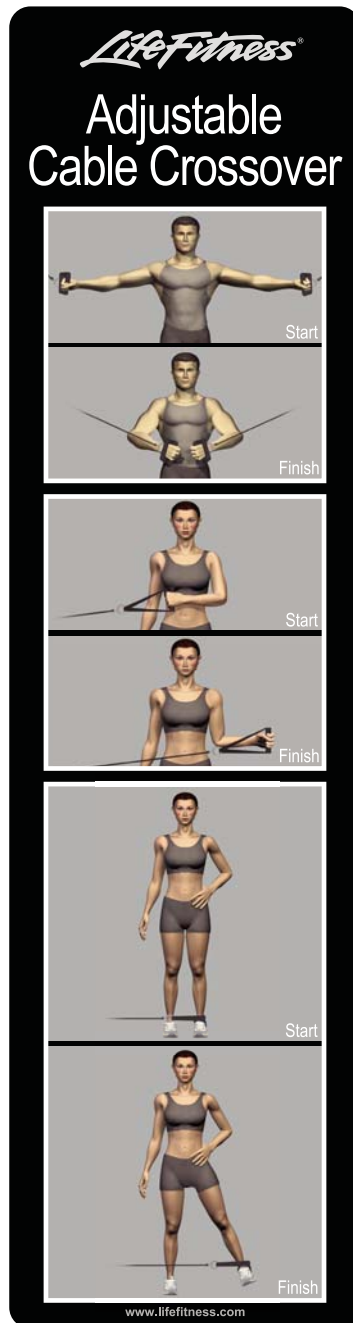

EXERCISE AND SETUP:

For a complete list of exercises and how to perform them please see exercise sections 5-A & 5-C.

Product Code - MJACO

Max User Weight:	300 lbs	136 kg
Resistance Ratio:	1:2	
Weight Stack:	2 x 190 lbs	2 x 95 kg
Effective User Resistance:	2 x 95 lbs	2 x 47.5 kg

PRODUCT DIMENSIONS WITH WORKING AREA (MJACO)

Size: in. = 174"L x 33"W x 94"H cm = 442cmL x 84cmW x 239cmH

Live Area: in. = 116"L x 256"W cm = 295cmL x 650cmW

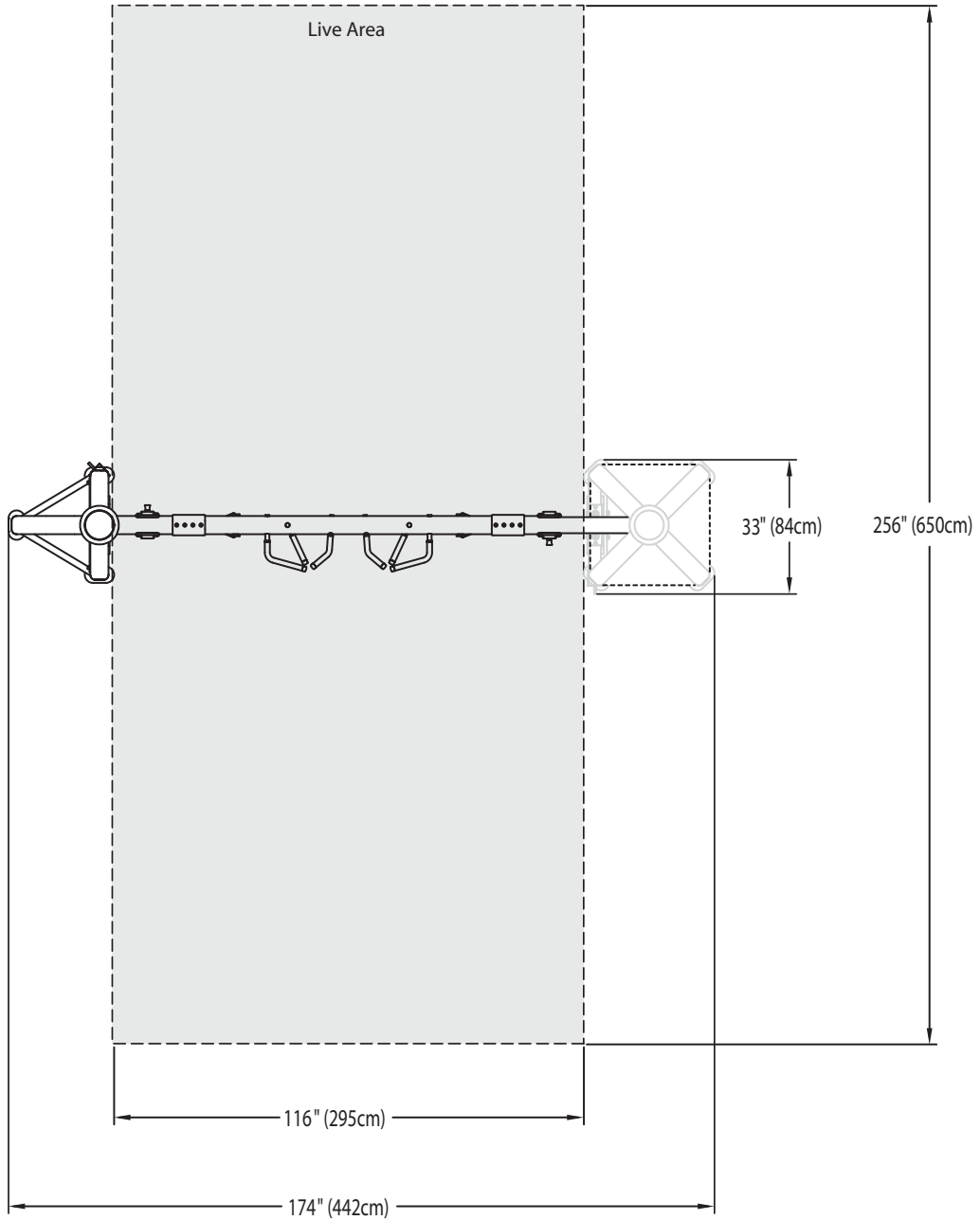

LABEL LOCATIONS (MJACO)

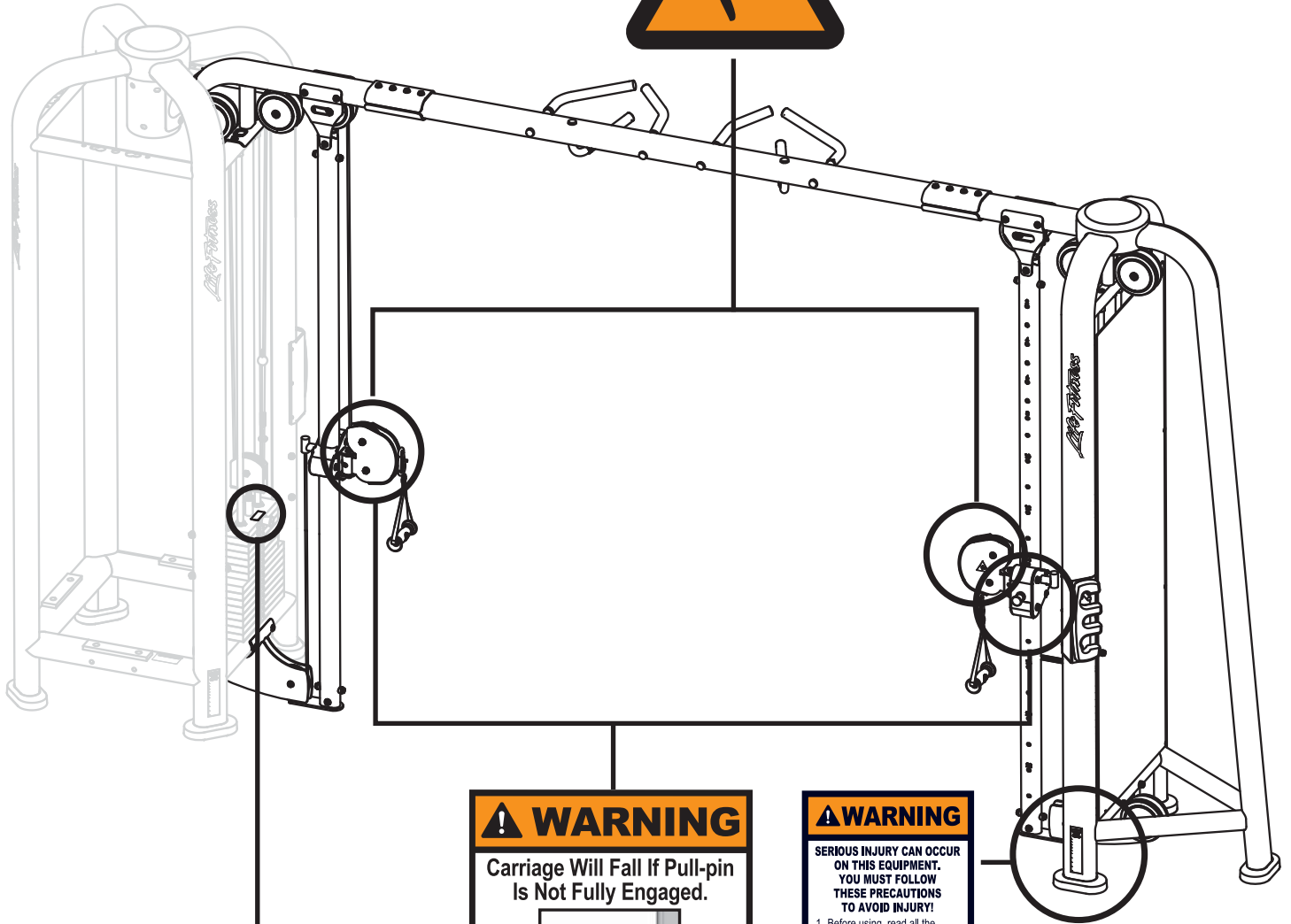

Weight stack label indicates resistance for each handle

! WARNING
Carriage Will Fall If Pull-pin Is Not Fully Engaged.



Ensure Full Engagement As Illustrated Here To Avoid Injury.

! WARNING

SERIOUS INJURY CAN OCCUR ON THIS EQUIPMENT. YOU MUST FOLLOW THESE PRECAUTIONS TO AVOID INJURY!

1. Before using, read all the warnings and obtain instruction on the use of this machine. Use only for intended exercise. **DO NOT** modify the machine.
2. Obtain a medical exam before beginning any exercise program.
3. Keep body, hair and clothing free of all moving objects.
4. Inspect the machines before use. **DO NOT** use if it appears damaged. **DO NOT** attempt to fix a broken or jammed machine. Notify staff immediately.
5. Be certain that weight pin is completely inserted. Use only the pin provided by the manufacturer. If unsure, seek assistance.
6. Never pin the weights or prop plate into an elevated position. **DO NOT** use the machine if found in this condition. **DO NOT** attempt to fix. Seek assistance.
7. Inspect cables and their connections before using machine. **DO NOT** attempt to fix. Seek assistance.
8. Use only the incremental weights supplied by the manufacturer. **DO NOT** use dumbbells or other means to add resistance to the machine.
9. Children must not be allowed near this machine. Supervise teenagers.
10. Manufacturer recommends that all equipment be secured to the floor to stabilize and eliminate rocking or tipping over. Use a licensed contractor.
11. **DO NOT REMOVE THIS LABEL. REPLACE IF DAMAGED.**

Multi Jungle Fixed Cable Crossover (MJFCO)

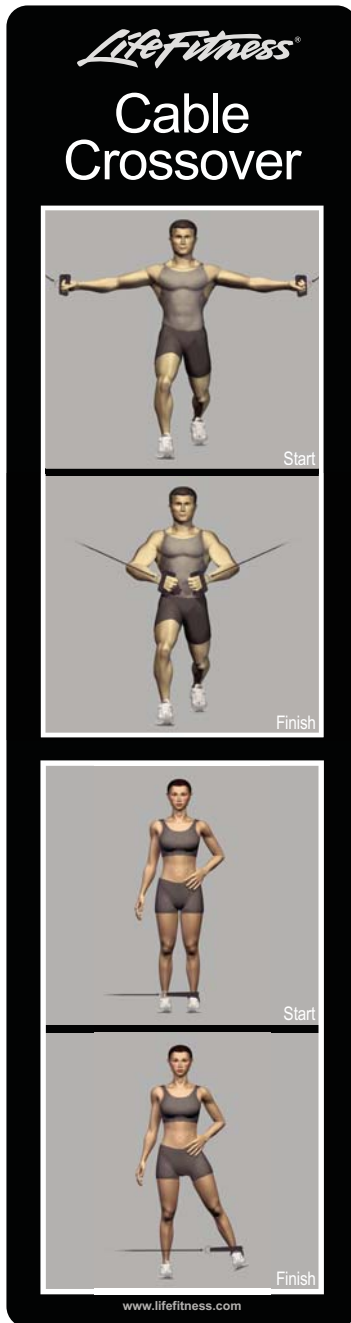

EXERCISE AND SETUP:

For a complete list of exercises and how to perform them please see exercise sections 5-A & 5-C.

Product Code - MJFCO

Max User Weight:	300 lbs	136 kg
Resistance Ratio:	1:2	
Weight Stack:	2 x 190 lbs	2 x 95 kg
Effective User Resistance:	2 x 95 lbs	2 x 47.5 kg

PRODUCT DIMENSIONS WITH WORKING AREA (MJFCO)

Size: in. = 149"L x 33"W x 94"H cm = 379cmL x 84cmW x 239cmH

Live Area: in. = 91"L x 256"W cm = 231cmL x 650cmW

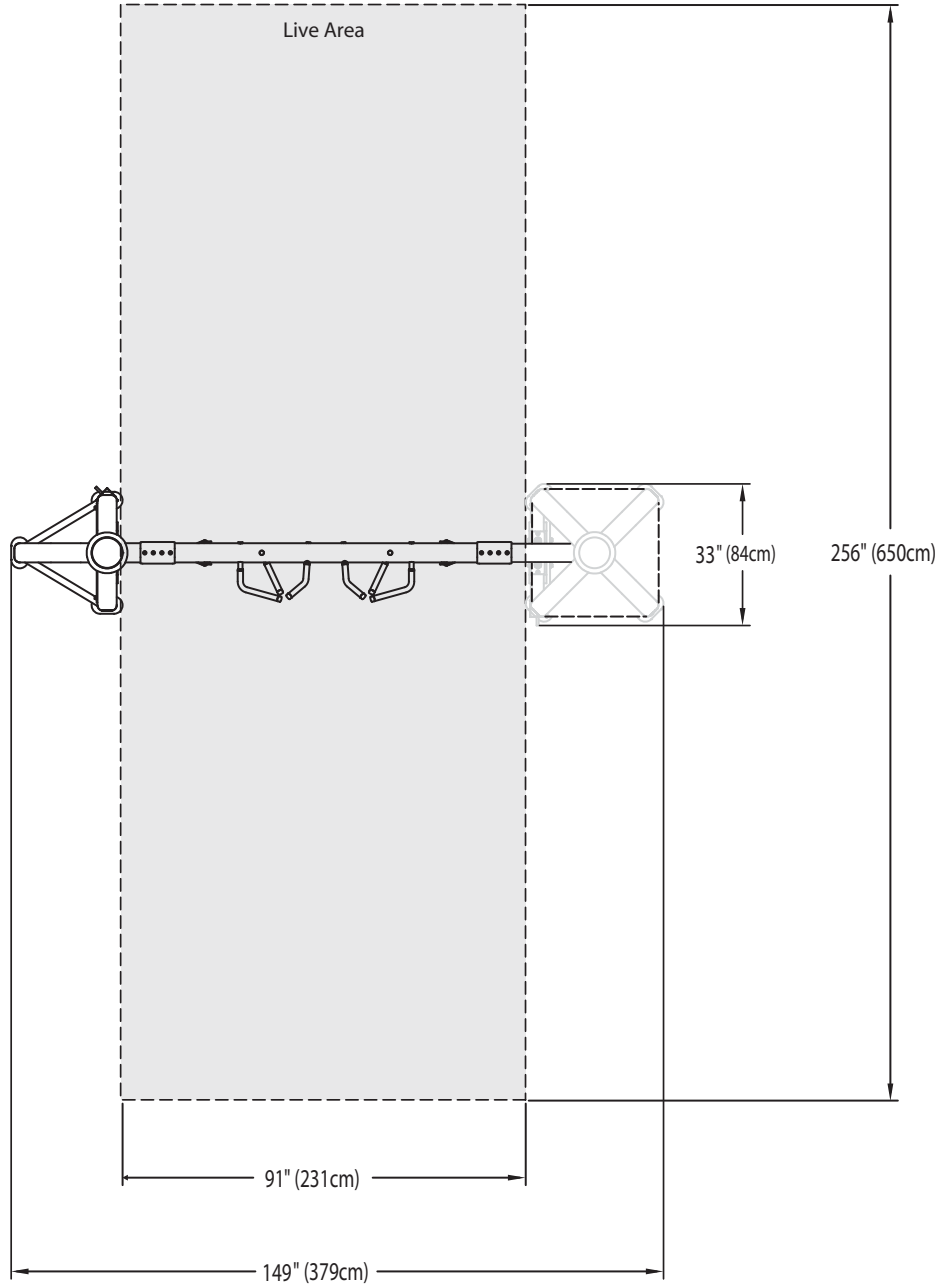

LABEL LOCATIONS (MJFCO)

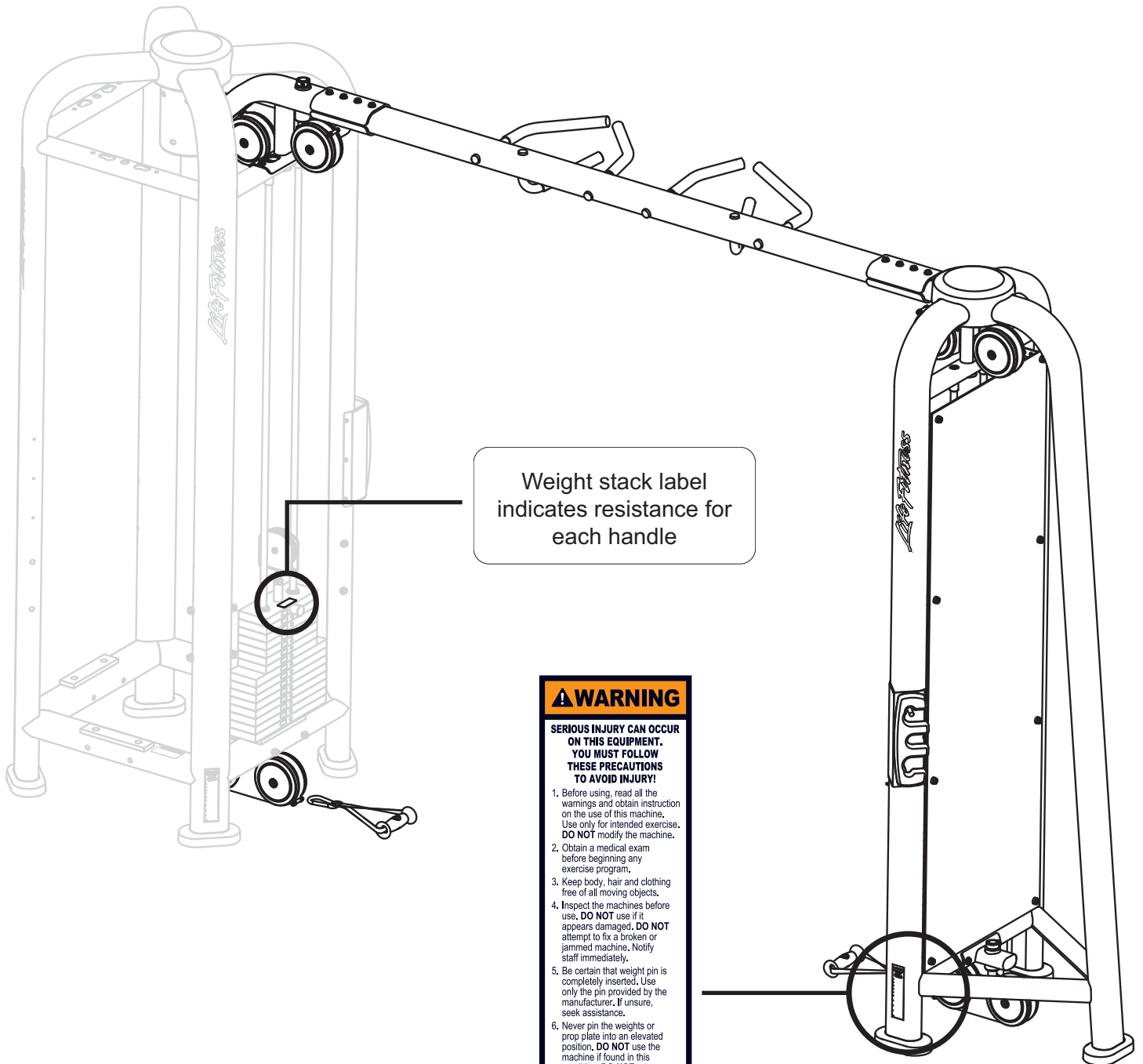

WARNING

SERIOUS INJURY CAN OCCUR ON THIS EQUIPMENT. YOU MUST FOLLOW THESE PRECAUTIONS TO AVOID INJURY!

1. Before using, read all the warnings and obtain instruction on the use of this machine. Use only for intended exercise. **DO NOT** modify the machine.
2. Obtain a medical exam before beginning any exercise program.
3. Keep body, hair and clothing free of all moving objects.
4. Inspect the machines before use, **DO NOT** use if it appears damaged. **DO NOT** attempt to fix a broken or jammed machine. Notify staff immediately.
5. Be certain that weight pin is completely inserted. Use only the pin provided by the manufacturer. If unsure, seek assistance.
6. Never pin the weights or prop plate into an elevated position. **DO NOT** use the machine if found in this condition. **DO NOT** attempt to fix. Seek assistance.
7. Inspect cables and their connections before using machine. **DO NOT** attempt to fix. Seek assistance.
8. Use only the incremental weights supplied by the manufacturer. **DO NOT** use dumbbells or other means to add resistance to the machine.
9. Children must not be allowed near this machine. Supervise teenagers.
10. Manufacturer recommends that all equipment be secured to the floor to stabilize and eliminate rocking or tipping over. Use a licensed contractor.
11. **DO NOT REMOVE THIS LABEL. REPLACE IF DAMAGED.**

Multi Jungle Adjustable Cable Crossover (MJAXO)

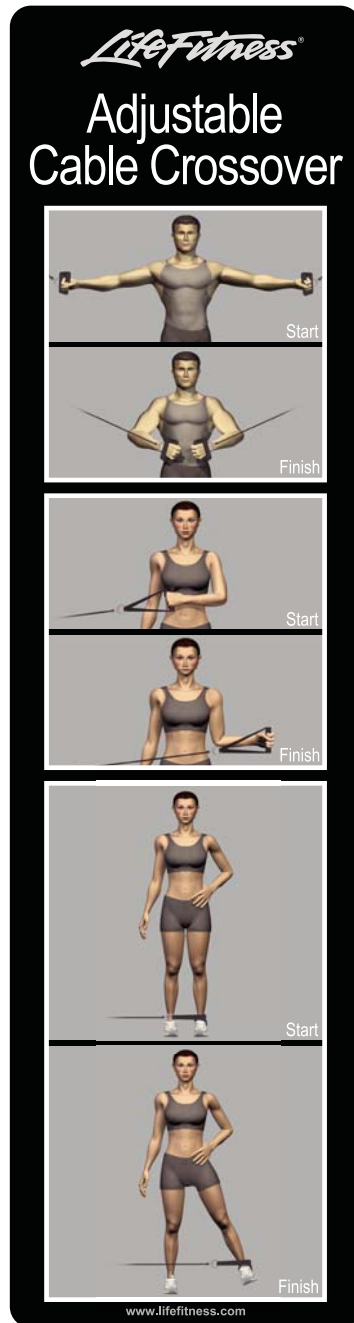

EXERCISE AND SETUP:

For a complete list of exercises and how to perform them please see exercise sections 5-A & 5-C.

Product Code - MJAXO

Max User Weight:	300 lbs	136 kg
Resistance Ratio:	1:2	
Weight Stack:	2 x 190 lbs	2 x 95 kg
Effective User Resistance:	2 x 95 lbs	2 x 47.5 kg

PRODUCT DIMENSIONS WITH WORKING AREA (MJAXO)

Size: in. = 180"L x 34"W x 94"H cm = 458cmL x 86cmW x 239cmH

Live Area: in. = 116"L x 256"W cm = 295cmL x 650cmW

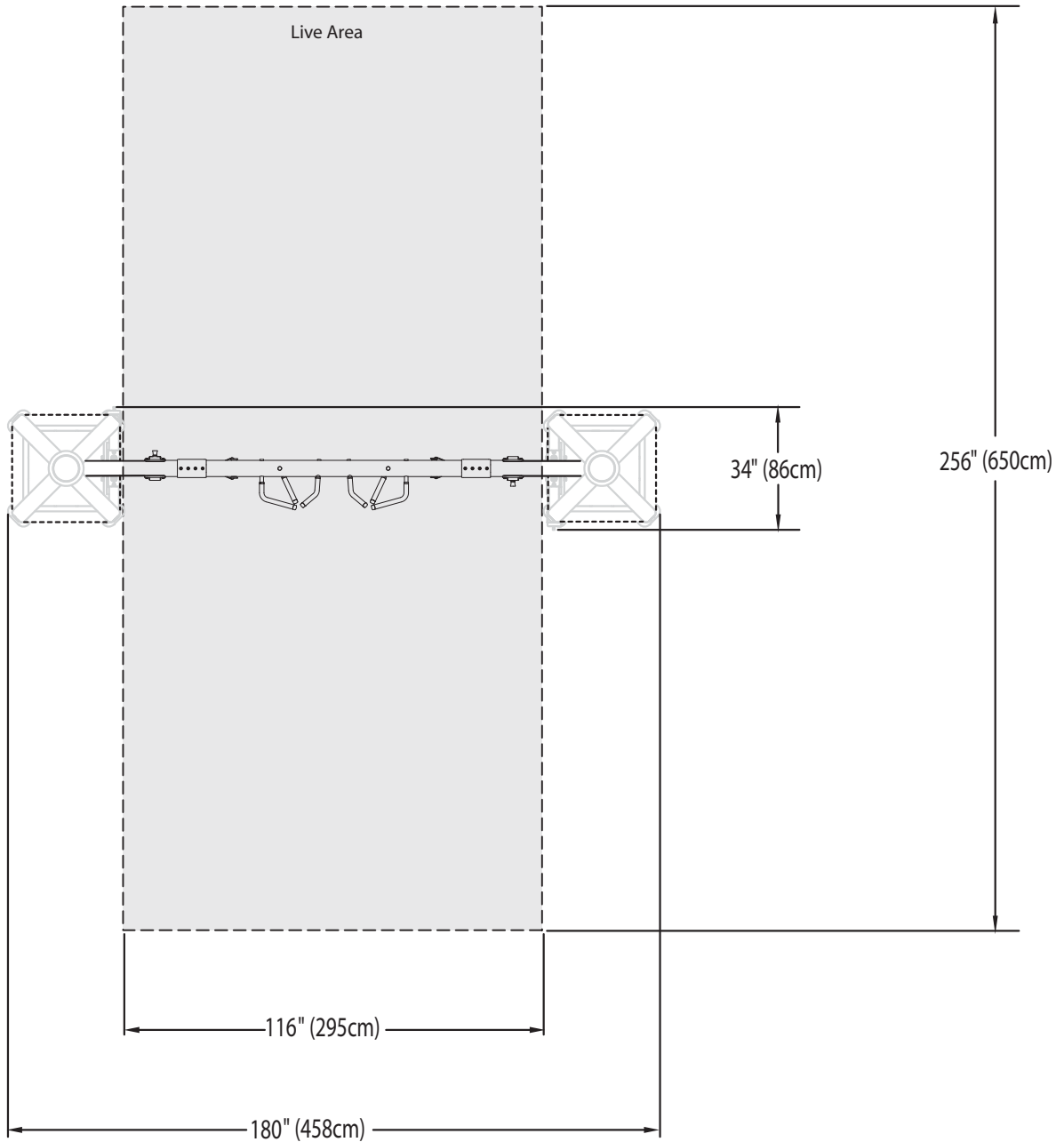

LABEL LOCATIONS (MJAXO)

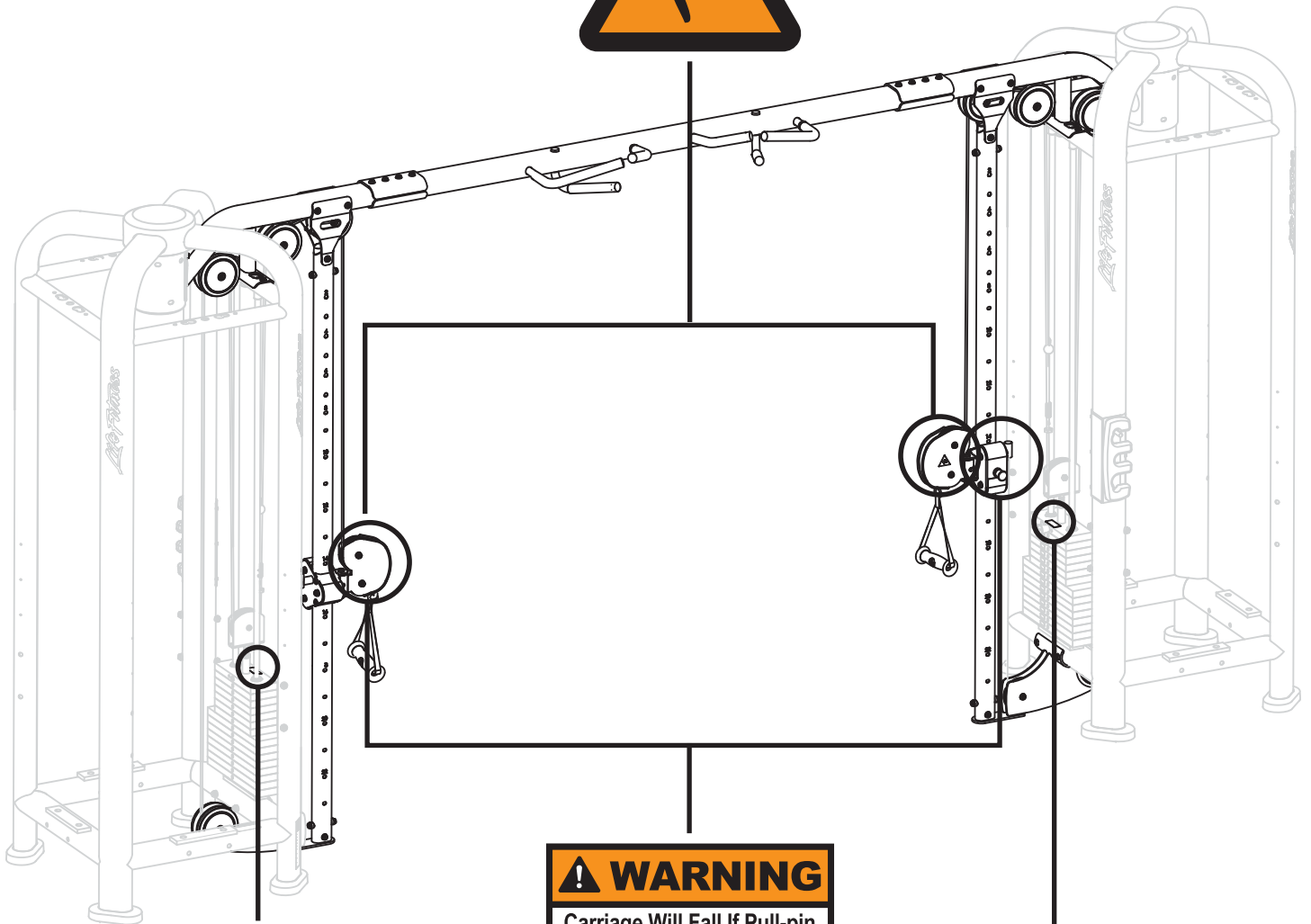

Weight stack label indicates resistance for each handle

! WARNING
Carriage Will Fall If Pull-pin Is Not Fully Engaged.



Ensure Full Engagement As Illustrated Here To Avoid Injury.

Weight stack label indicates resistance for each handle

Multi Jungle Fixed Cable Crossover (MJFXO)

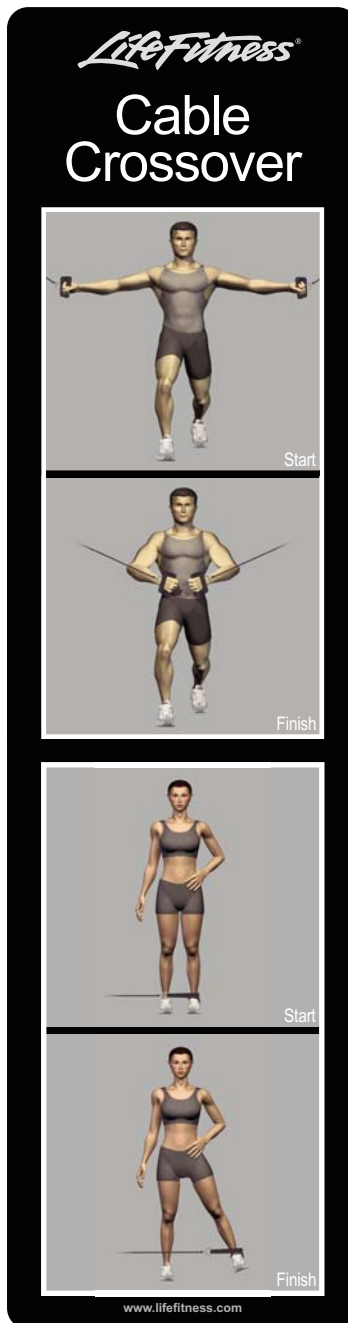

EXERCISE AND SETUP:

For a complete list of exercises and how to perform them please see exercise sections 5-A & 5-C.

Product Code - MJFXO

Max User Weight:	300 lbs	136 kg
Resistance Ratio:	1:2	
Weight Stack:	2 x 190 lbs	2 x 95 kg
Effective User Resistance:	2 x 95 lbs	2 x 47.5 kg

PRODUCT DIMENSIONS WITH WORKING AREA (MJFXO)

Size: in. = 156"L x 34"W x 74"H cm = 396cmL x 86cmW x 239cmH

Live Area: in. = 92"L x 256"W cm = 233cmL x 650cmW

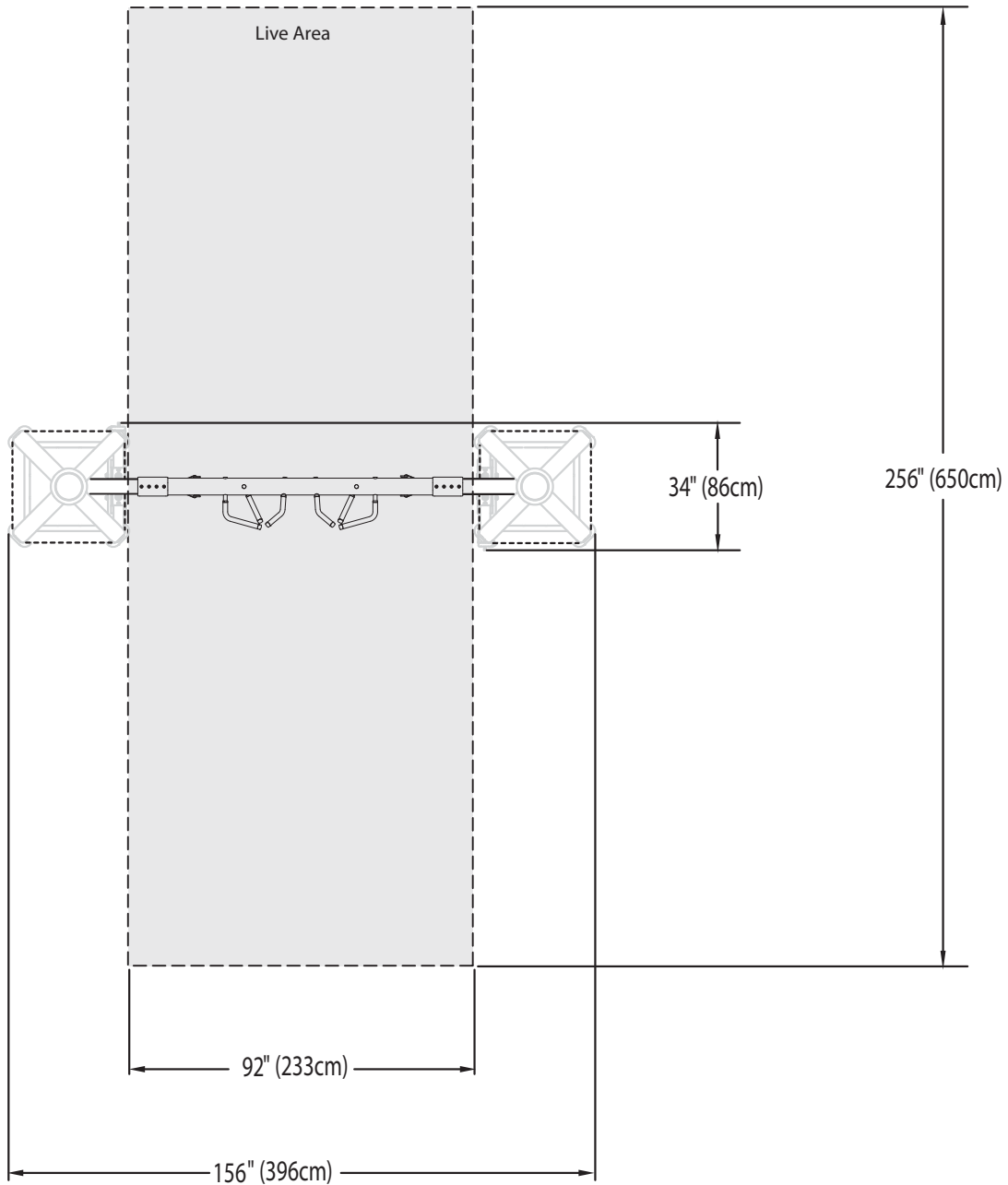

LABEL LOCATIONS (MJFXO)

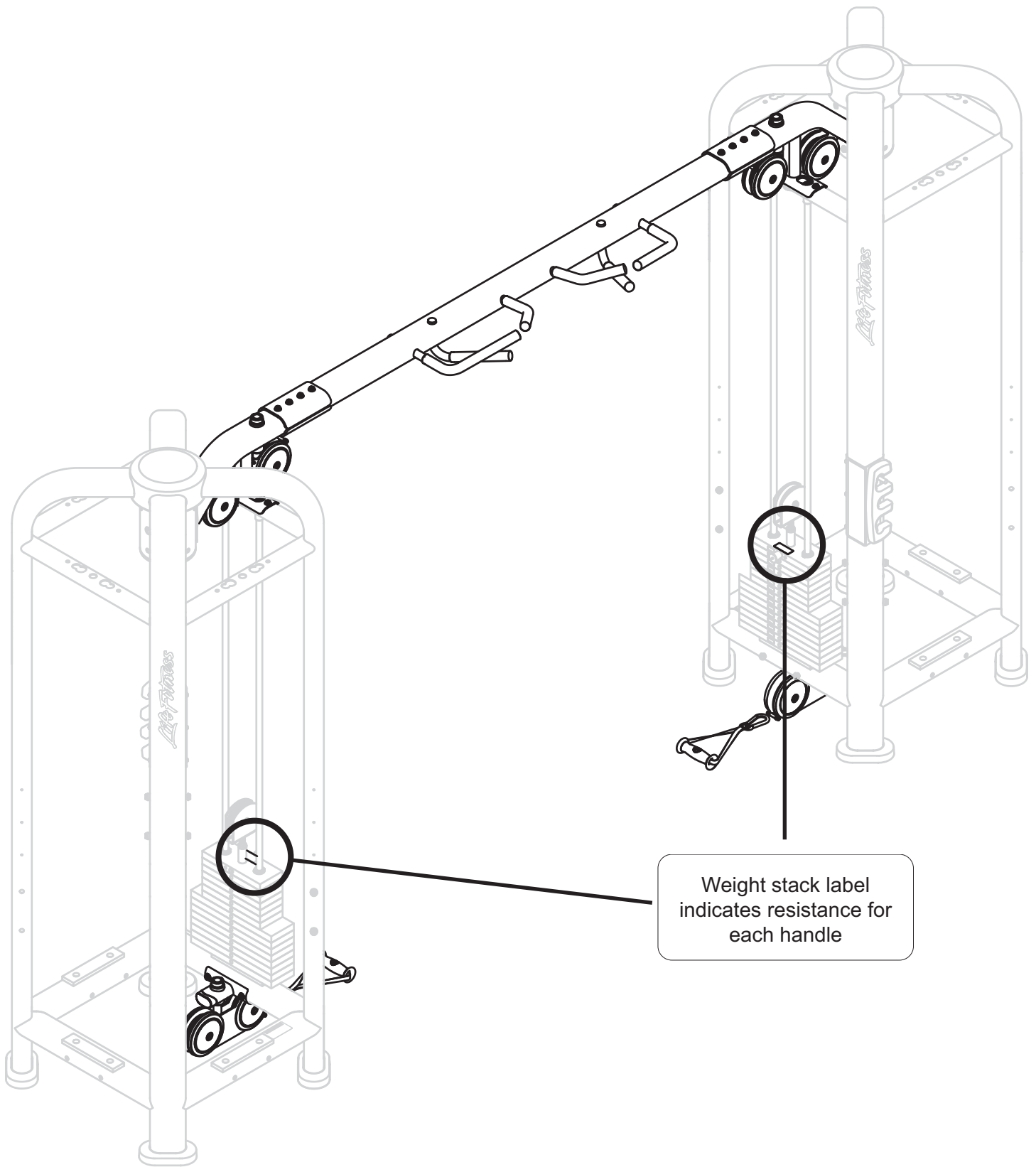

Weight stack label indicates resistance for each handle

Multi Jungle Lat Pulldown (MJLP)



Muscles Exercised: Latissimus Dorsi and Biceps

Setup

Check the weight stacks to ensure appropriate resistance. Sit and grip handles, then pull down and sit with thighs under pads. Upper body is positioned leaning slightly back from the hips, pulling directly over shoulders.

TIP: Attempt to stabilize the body without the use of the thigh pads until necessary.

Performing the Exercise

With a controlled motion, draw down the handles directly over the shoulders until hands reach shoulder height, then extend the handles up until arms are fully extended. Return the handles to the start position and repeat the motion, while maintaining proper body positioning.

TIP: While performing the exercise think about lowering your elbows towards your lower back. This will re-enforce the correct exercise position and increases the mental concentration on the Latissimus Dorsi.

Product Code - MJLP

Max User Weight:	300 lbs	136 kg
Resistance Ratio:	1:1	
Weight Stack:	260 lbs	130 kg

PRODUCT DIMENSIONS WITH WORKING AREA (MJLP)

Size: in. = 69"L x 48"W x 94"H cm = 176cmL x 121cmW x 239cmH

Live Area: in. = 93"L x 84"W cm = 237cmL x 212cmW

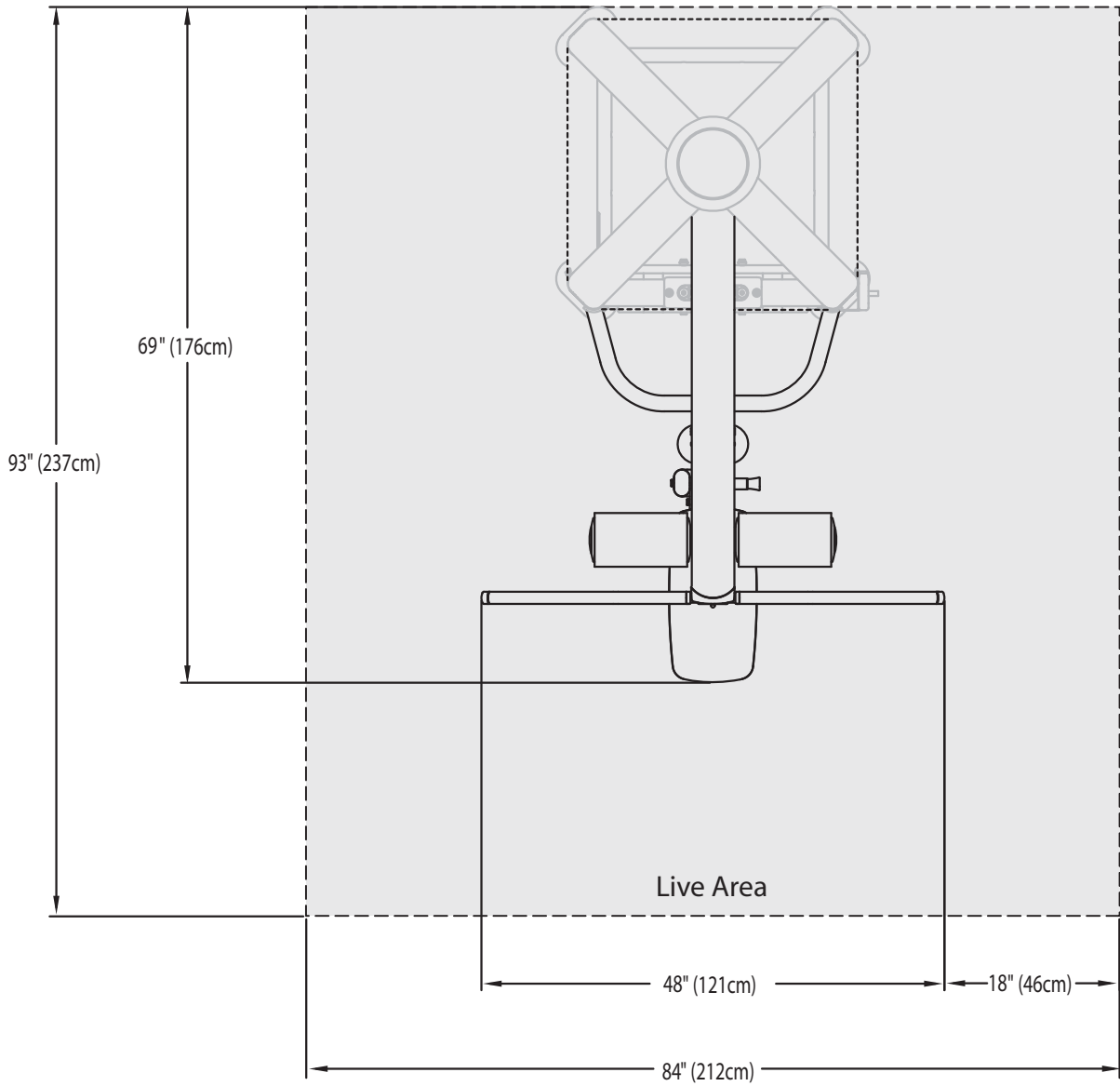

LABEL LOCATIONS (MJLP)

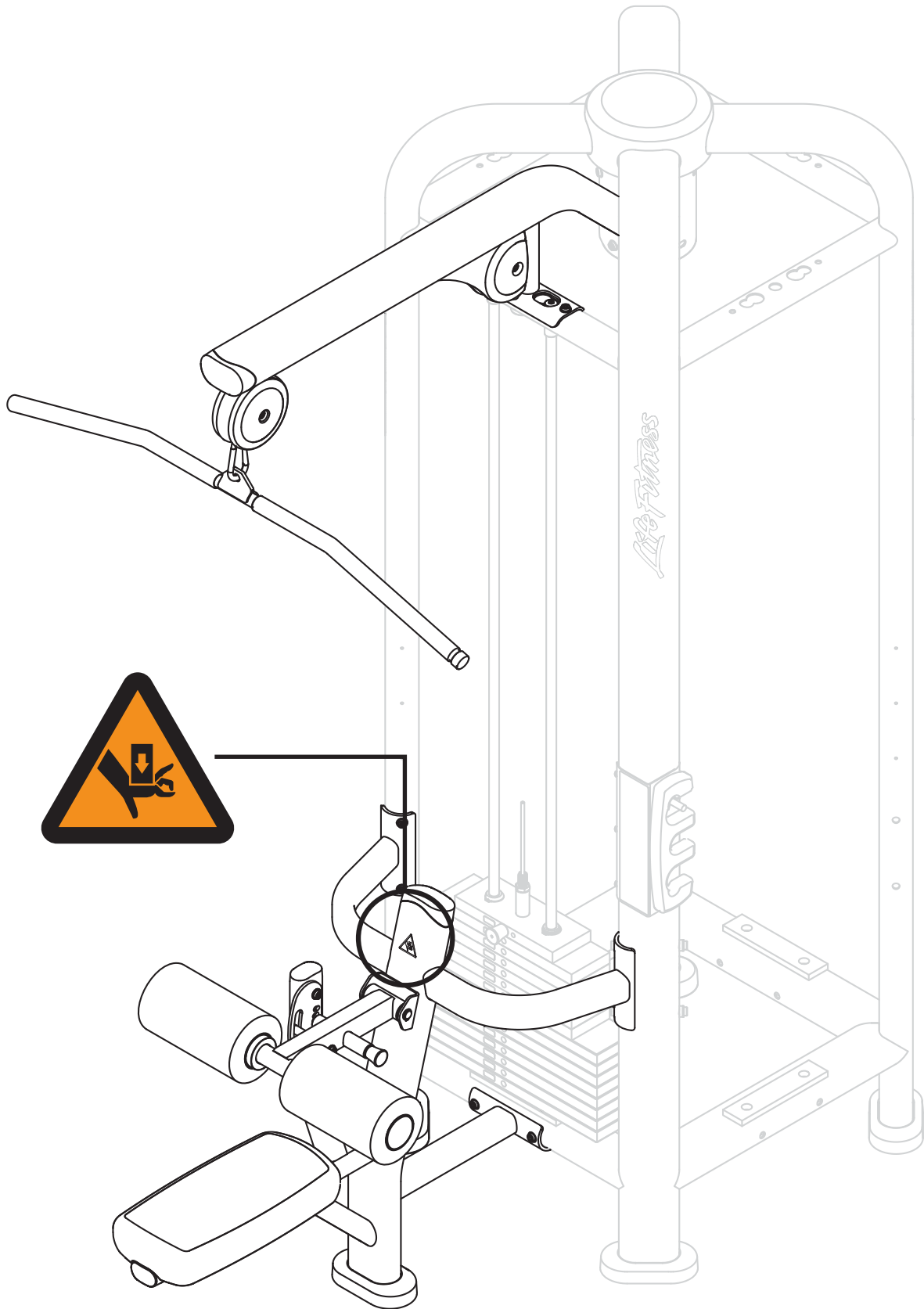

Multi Jungle Dual Pulley Pulldown (MJLPD)

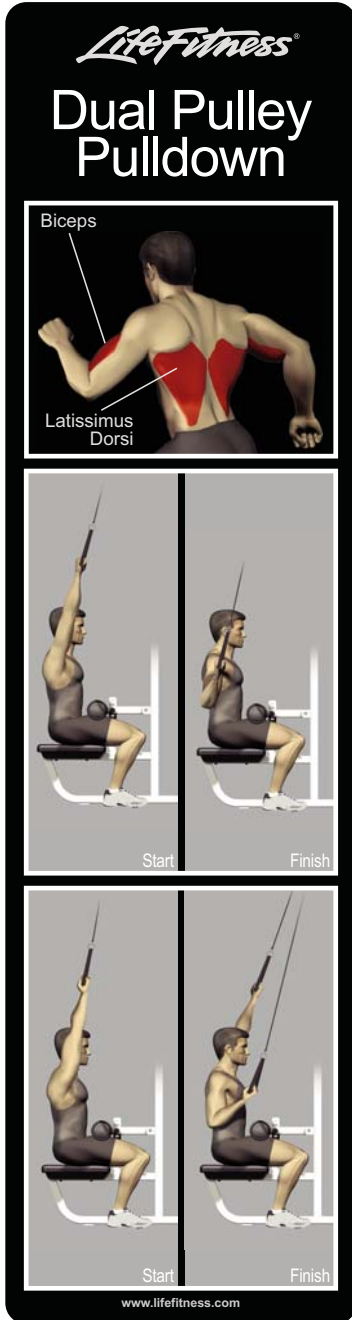

Muscles Exercised: Latissimus Dorsi and Biceps

Setup

Check the weight stacks to ensure appropriate resistance. Sit and grip handles, then pull down and sit with thighs under pads. Upper body is positioned leaning slightly back from the hips, pulling directly over shoulders.

TIP: Attempt to stabilize the body without the use of the thigh pads until necessary.

Performing the Exercise

With a controlled motion, draw down the handles directly over the shoulders until hands reach shoulder height, then extend the handles up until arms are fully extended. Return the handles to the start position and repeat the motion, while maintaining proper body positioning.

TIP: While performing the exercise think about lowering your elbows towards your lower back. This will re-enforce the correct exercise position and increases the mental concentration on the Latissimus Dorsi.

Product Code - MJLPD

Max User Weight:	300 lbs	136 kg
Resistance Ratio:	1:2 per handle	
Weight Stack:	260 lbs	130 kg
Effective User Resistance:	2 x 130 lbs per handle	2 x 65 kg per handle

PRODUCT DIMENSIONS WITH WORKING AREA (MJLPD)

Size: in. = 69"L x 48"W x 94"H cm = 176cmL x 121cmW x 239cmH

Live Area: in. = 93"L x 84"W cm = 237cmL x 212cmW

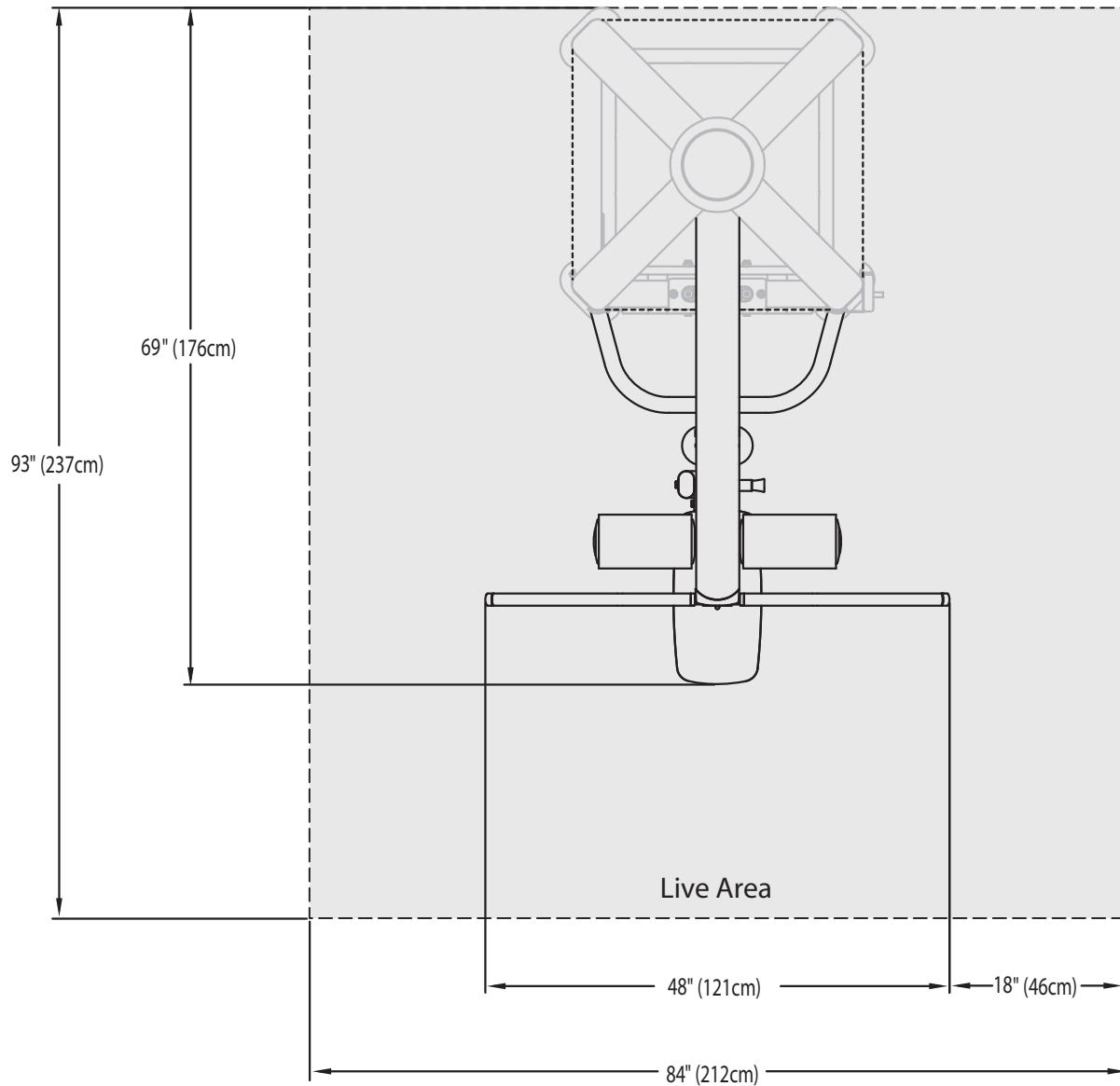

LABEL LOCATIONS (MJLPD)

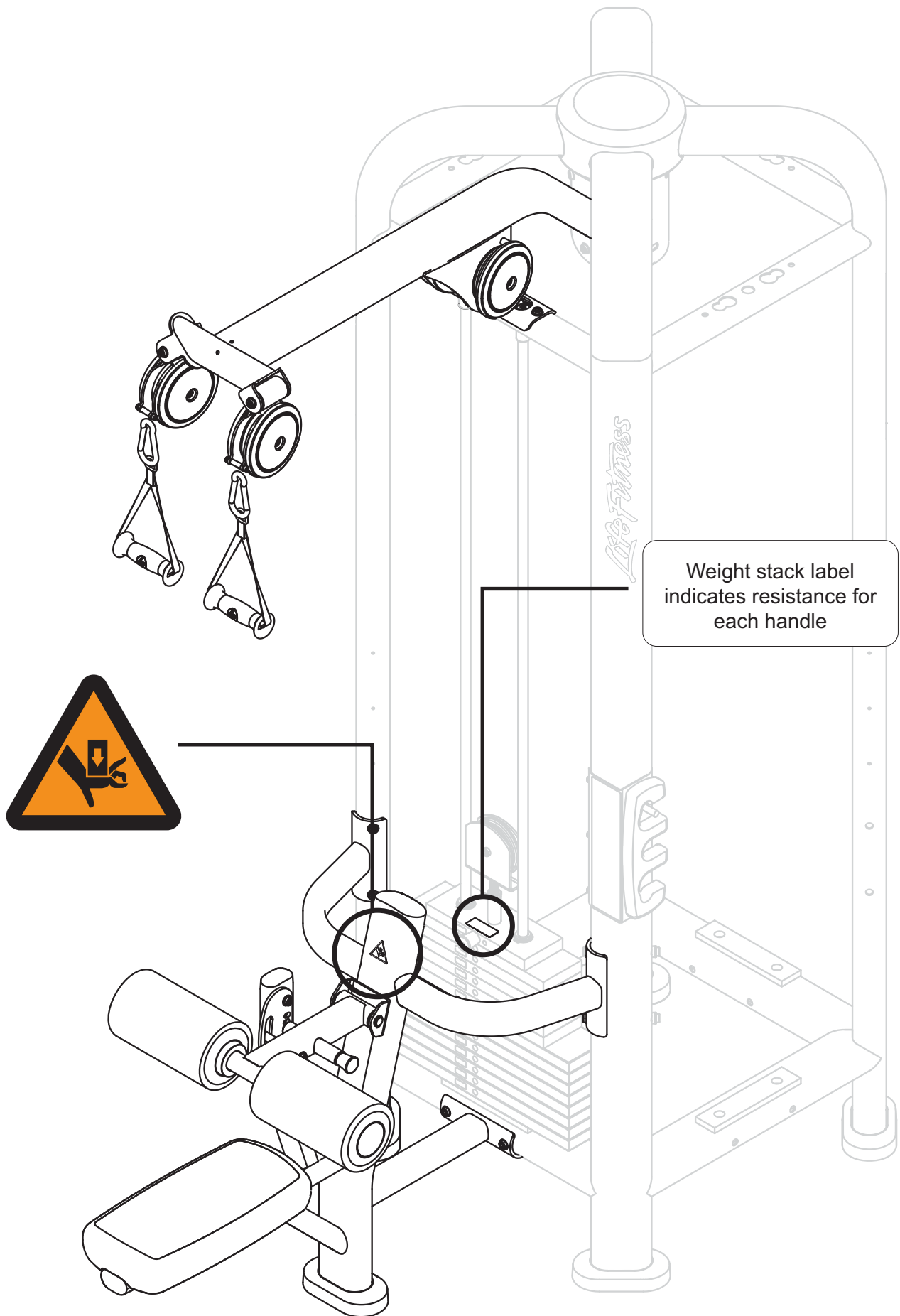

Multi Jungle Low Row (MJRW)



Muscles Exercised: Latissimus Dorsi, Trapezius, Rhomboids, Teres Major and Minor, Posterior Deltoids & Biceps

Setup

Check the weight stack to ensure appropriate resistance. Sit, grip the handles and position body with feet on the platform and head and chest-up.

Performing the Exercise

Stabilize the body in position, pressing feet firmly on foot platform. Stabilize upper body by drawing in abdominals. With a controlled motion, draw back the arms as far as it can be controlled. Return the handles to the start position, without letting the resistance rest on the stack. Repeat the motion, while maintaining proper body positioning.

TIP: While performing the exercise, think about drawing the elbows back beyond the body and stabilizing the upper body as this increases the mental concentration on the muscles being trained.

Product Code - MJRW

Max User Weight:	300 lbs	136 kg
Resistance Ratio:	1:1	
Weight Stack:	260 lbs	130 kg

PRODUCT DIMENSIONS WITH WORKING AREA (MJRW)

Size: in. = 106"L x 33"W x 94"H cm = 270cmL x 84cmW x 239cmH

Live Area: in. = 130"L x 69"W cm = 331cmL x 175cmW

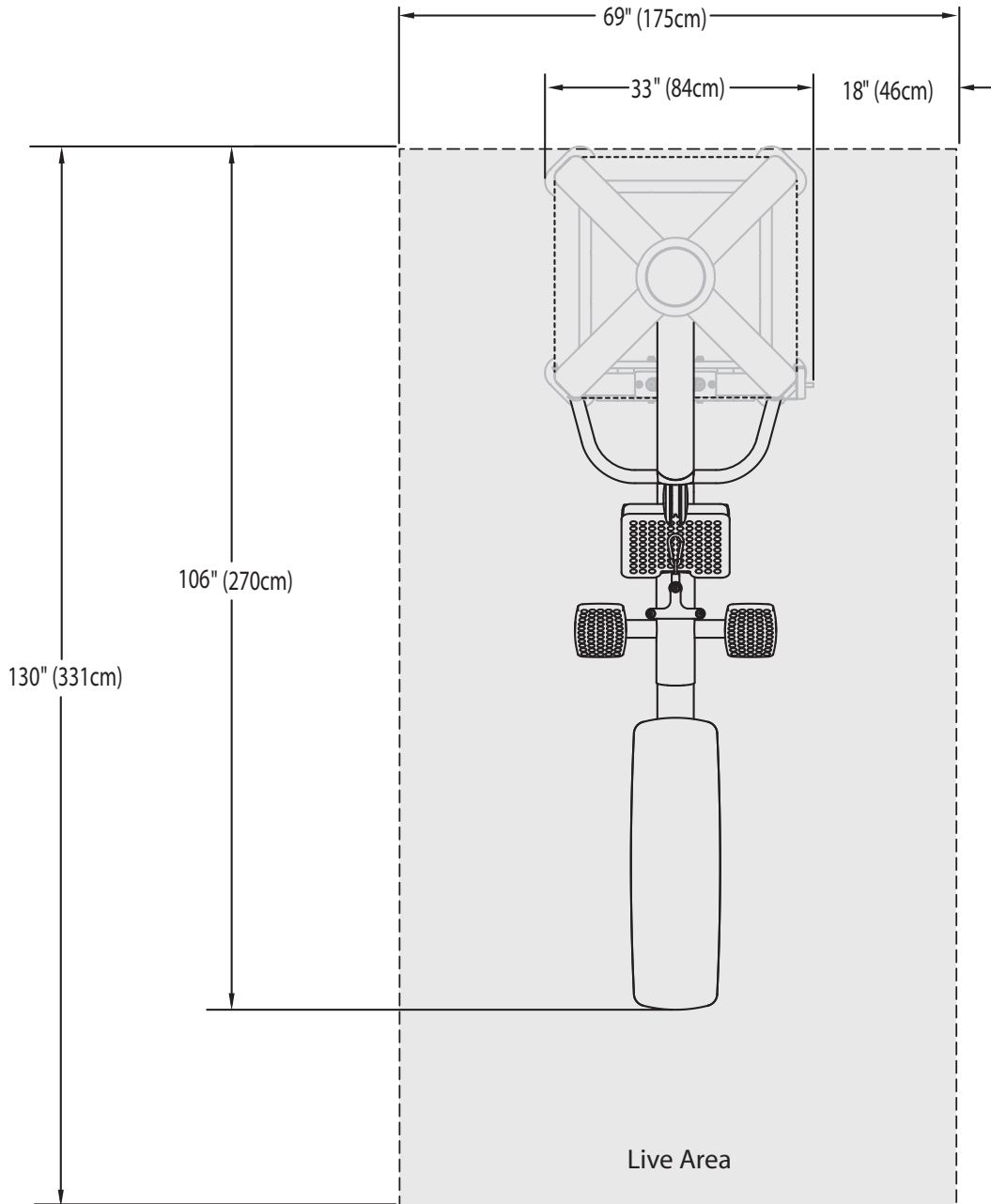

Multi Jungle Dual Pulley Row (MJRWD)

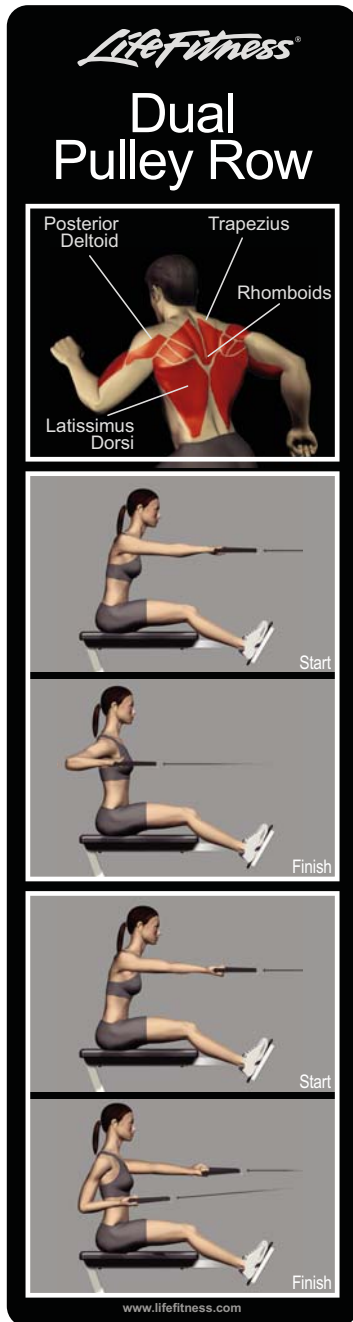

Muscles Exercised: Latissimus Dorsi, Trapezius, Rhomboids, Teres Major and Minor, Posterior Deltoids & Biceps

Setup

Check the weight stack to ensure appropriate resistance. Sit, grip the handles and position body with feet on the platform and head and chest-up.

Performing the Exercise

Stabilize the body in position, pressing feet firmly on foot platform. Stabilize upper body by drawing in abdominals. With a controlled motion, draw back the arms as far as can be controlled. Return the handles to the start position, without letting the resistance rest on the stack. Repeat the motion, while maintaining proper body positioning.

TIP: While performing the exercise, think about drawing the elbows back beyond the body and stabilizing the upper body as this increases the mental concentration on the muscles being trained.

Product Code - MJRWD

Max User Weight:	300 lbs	136 kg
Resistance Ratio:	1:2 per handle	
Weight Stack:	260 lbs	130 kg
Effective User Resistance:	2 x 130 lbs per handle	2 x 65 kg per handle

PRODUCT DIMENSIONS WITH WORKING AREA (MJRW)

Size: in. = 106"L x 33"W x 94"H cm = 270cmL x 84cmW x 239cmH
Live Area: in. = 130"L x 69"W cm = 331cmL x 175cmW

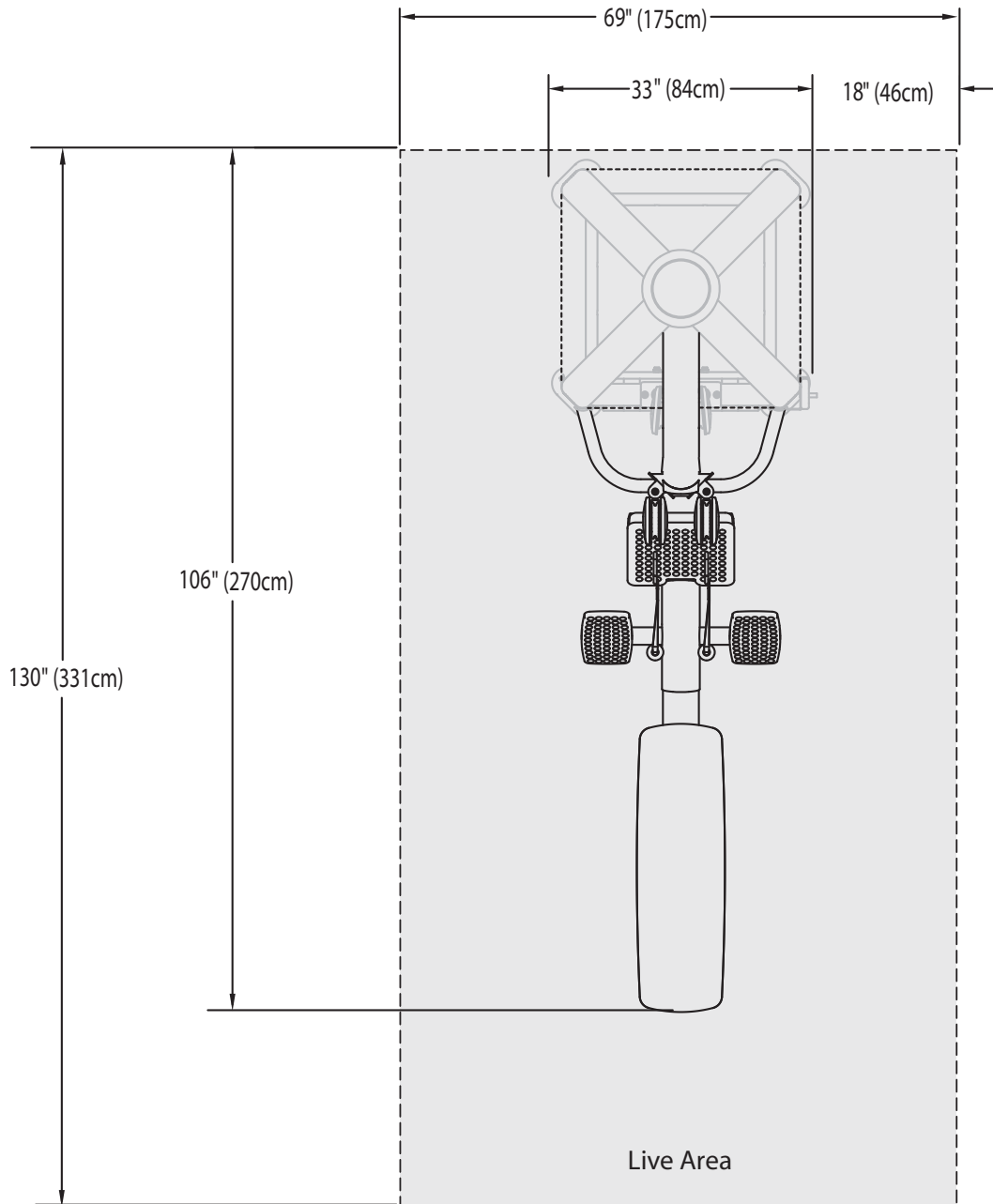

LABEL LOCATIONS (MJRWD)

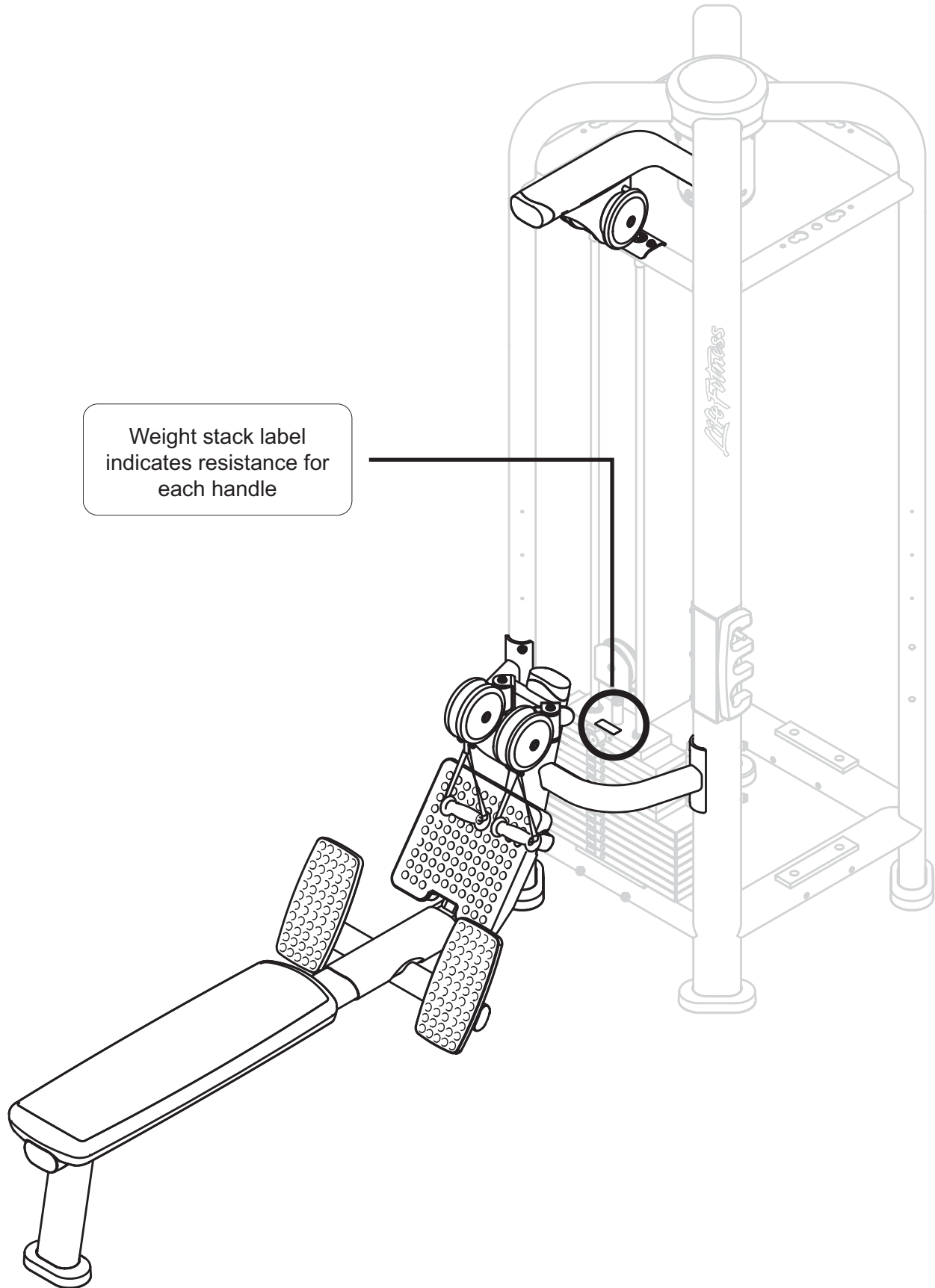

Multi Jungle Triceps Pushdown (MJTP)

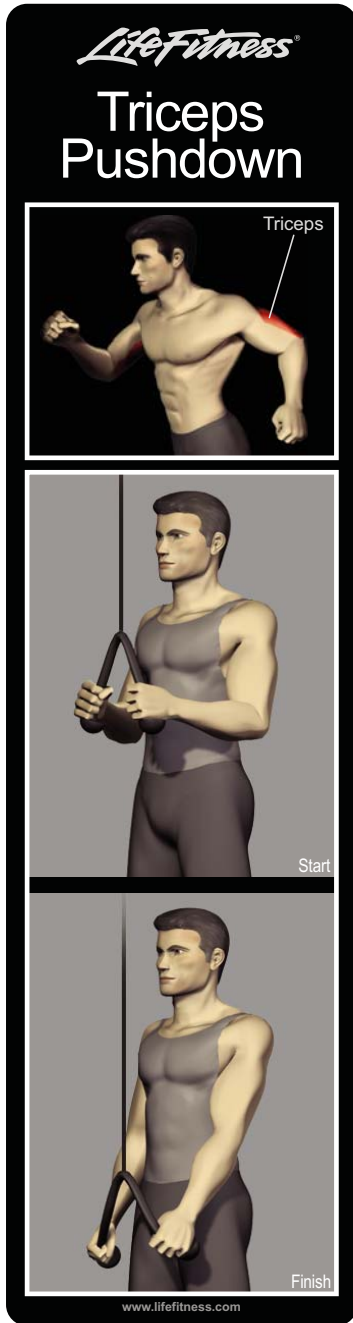

Muscles Exercised: Triceps

Setup

Position the pulley at a high position with the handles at chest level. Take an overhand grip on the handles. Position feet shoulder width apart. Keep chest out and back straight.

Performing the Exercise

Begin with the handles at chest level, elbows bent a little more than 90 degrees. With upper arms held firmly against sides, push the handles down until elbows are locked out. Slowly return to the beginning position.

Product Code - MJTP

Max User Weight:	300 lbs	136 kg
Resistance Ratio:	1:1	
Weight Stack:	190 lbs	95 kg

PRODUCT DIMENSIONS WITH WORKING AREA (MJTP)

Size: in. = 55"L x 33"W x 94"H cm = 139cmL x 84cmW x 239cmH

Live Area: in. = 79"L x 69"W cm = 200cmL x 175cmW

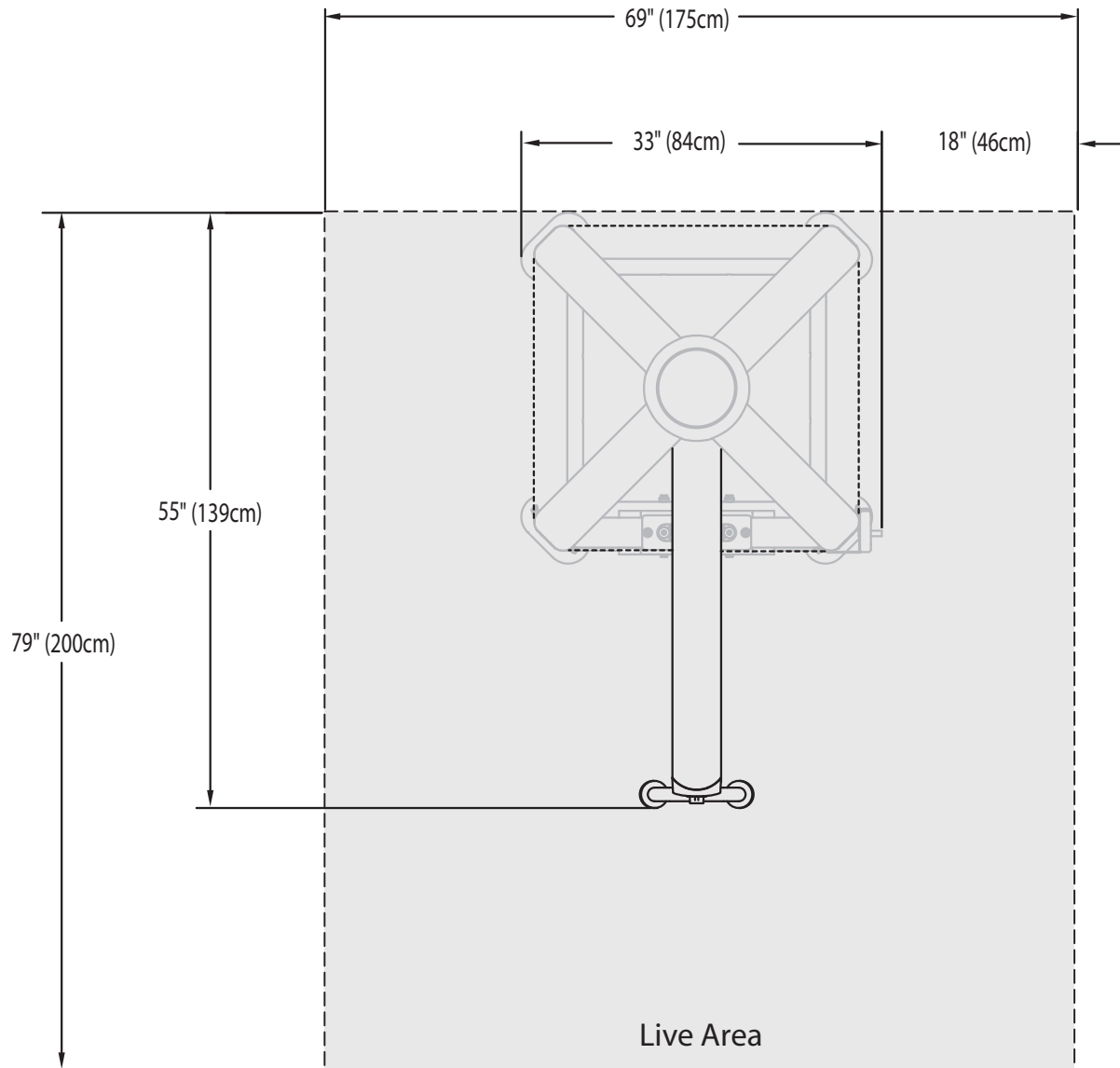

5. Exercises

Section 5-A

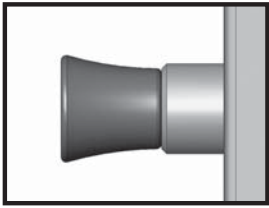

Note: Before starting any exercise or after completing any height adjustment of the carriage assembly, verify that the pull pin is fully engaged prior to use.

HIP ADDUCTION

Muscles Exercised: Adductors

Setup: Position the pulley at a low position with the ankle strap. Stand sideways from the machine so leg with ankle strap is closest to the pulley. Step away from the machine with wide stance. Stand on far foot, allowing near leg to be pulled towards pulley. Place hands on hips for balance or grasp a bar.

Performing the Exercise: With a controlled motion, pull the leg with ankle strap medially across the front of the stance leg. Slowly return to the beginning position.

EXTERNAL ROTATION

Muscles Exercised: Infraspinatus, Teres Major, Rear Deltoid

Setup: Position the pulley at a mid position with the handles at waist level. Stand sideways from the machine. Grasp handle with outside hand, thumb pointing up. Keep chest out and back straight.

Performing the Exercise: With upper arm held firmly against side, move the handle in an outward arc, away from body, keeping forearm parallel to floor. Slowly return to the beginning position.

HIP ABDUCTORS

Muscles Exercised: Abductors (Gluteus)

Setup: Position the pulley at a low position with the ankle strap. Stand sideways from the machine so leg with ankle strap is furthest from the pulley. Stand on near foot. Place hands on hips for balance or grasp a bar.

Performing the Exercise: With a controlled motion, raise the leg with ankle strap laterally as high as possible. Slowly return to the beginning position.

INTERNAL ROTATION

Muscles Exercised: Subscapularis, Pectoralis Major

Setup: Position the pulley at a mid position with the handles at waist level. Stand sideways from the machine. Grasp handle with inside hand, thumb pointing up. Keep chest out and back straight.

Performing the Exercise: With upper arm held firmly against side, move the handle in an inward arc, across the front of the body, keeping forearm parallel to floor. Slowly return to the beginning position.

Section 5-A (continued)

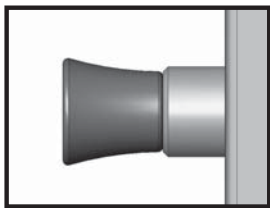

Note: Before starting any exercise or after completing any height adjustment of the carriage assembly, verify that the pull pin is fully engaged prior to use.

STANDING LEG EXTENSION

Muscles Exercised: Quadriceps

Setup: Position the pulley at a low position with the ankle strap. Face away from the machine. With hands on hips for balance, lift the leg with ankle strap off the ground until leg is bent at 90 degrees.

Performing the Exercise: Keeping upper leg stable and with a controlled motion, extend the leg at the knee until near full extension. Slowly return to the beginning position.

BICEP CURL

Muscles Exercised: Biceps

Setup: Position the pulley at a low position with the handles below waist height. Grasp handles with an underhand grip. Position feet shoulder width apart. Keep chest out and back straight.

Performing the Exercise: With a controlled motion, curl the handles up toward the shoulder. Lower the handles back down until arm is fully extended.

Section 5-B

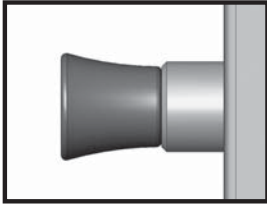

Note: Before starting any exercise or after completing any height adjustment of the carriage assembly, verify that the pull pin is fully engaged prior to use.

STANDING ROW

Muscles Exercised: Latissimus Dorsi, Trapezius, Posterior Deltoid, Rhomboid, Teres Major, Biceps

Setup: Position the pulleys at a mid to high position with the handles at chest level. Take an overhand grip on the handles. Place one foot forward for support. Keep chest out and back straight. Do not arch back.

Performing the Exercise: Begin with arms at full extension, pull arms back until elbows are along side body and handles are near chest height. Slowly return to the beginning position.

CHEST PRESS

Muscles Exercised: Pectoralis Major, Anterior Deltoid, Triceps

Setup: Position the pulleys at a mid to high position with the handles at chest level. Take an overhand grip on the handles. Place one foot back for support. Keep chest out and back straight.

Performing the Exercise: Begin with the handles at mid chest level and a slightly wider than shoulder-width grip. With a controlled motion, push the handles out until arms are fully extended. Slowly return to the beginning position.

SHOULDER PRESS

Muscles Exercised: Deltoids, Triceps

Setup: Position the pulleys at a low position with the handles at shoulder level while seated. Take an overhand grip on the handles. Position feet shoulder width apart. Keep chest out and back straight.

Performing the Exercise: Begin with the handles at shoulder height and a slightly wider than shoulder-width grip. With a controlled motion, push the handles up until arms are fully extended. Slowly return to the beginning position.

STANDING INCLINE CHEST PRESS

Muscles Exercised: Pectoralis Major, Anterior Deltoid, Triceps

Setup: Position the pulleys at a mid position with the handles at chest level. Take an overhand grip on the handles. Place one foot back for support. Keep chest out and back straight.

Performing the Exercise: Begin with the handles at mid chest level and a slightly wider than shoulder-width grip. With a controlled motion, push the handles forward and upward at 30 to 45 degrees until arms are fully extended. Slowly return to the beginning position.

Section 5-B (continued)

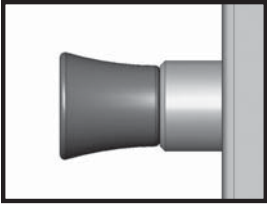

Note: Before starting any exercise or after completing any height adjustment of the carriage assembly, verify that the pull pin is fully engaged prior to use.

STANDING DECLINE CHEST PRESS

Muscles Exercised: Pectoralis Major, Anterior Deltoid, Triceps

Setup: Position the pulleys at a mid to high position with the handles at chest level. Take an overhand grip on the handles. Place one foot back for support. Keep chest out and back straight.

Performing the Exercise: Begin with the handles at mid chest level and a slightly wider than shoulder-width grip. With a controlled motion, push the handles forward and downward at 30 to 45 degrees until arms are fully extended. Slowly return to the beginning position.

BENCH CHEST PRESS

Muscles Exercised: Pectoralis Major, Anterior Deltoid, Triceps

Setup: Lay bench flat and push bench into machine to allow shoulders to be even with pulleys. Position the pulleys low so handles are at chest level when lying on bench. Take an overhand grip on the handles.

Performing the Exercise: Begin with the handles at mid chest level and a slightly wider than shoulder-width grip. With a controlled motion, push the handles up until arms are fully extended. Slowly return to the beginning position.

BENCH INCLINE PRESS

Muscles Exercised: Pectoralis Major, Anterior Deltoid, Triceps

Setup: Position bench back at 30 to 45 degrees and push bench into machine to allow shoulders to be even with pulleys. Position the pulleys low so handles are at chest level when lying on bench. Take an overhand grip on the handles.

Performing the Exercise: Begin with the handles at upper chest level and a slightly wider than shoulder-width grip. With a controlled motion, push the handles up until arms are fully extended. Slowly return to the beginning position.

SEATED SHOULDER PRESS

Muscles Exercised: Deltoids, Triceps

Setup: Position bench back upright and push bench into machine to allow shoulders to be even with pulleys. Position the pulleys low so handles are at shoulder level when sitting on bench. Take an overhand grip on the handles.

Performing the Exercise: Begin with the handles at shoulder level and a slightly wider than shoulder-width grip. With a controlled motion, push the handles up until arms are fully extended. Slowly return to the beginning position.

Section 5-B (continued)

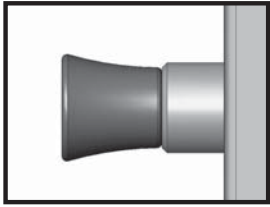

Note: Before starting any exercise or after completing any height adjustment of the carriage assembly, verify that the pull pin is fully engaged prior to use.

SQUAT

Muscles Exercised: Quadriceps, Hamstrings, Glutes

Setup: Position the pulleys at a low position with the handles at the abdominal region when standing. Squat below bar and begin with the bar across the back of shoulders and knees bent so thighs are parallel to the floor. Feet should be shoulder-width apart and grip should be wider than shoulder-width. Keep chest out and back straight. Do not arch back.

Performing the Exercise: Begin with the handles at chest level and arms spread apart and elbows slightly bent. With a controlled motion, squeeze the handles together in front of the body until handles nearly touch at waist height. Slowly return to the beginning position.

Section 5-C

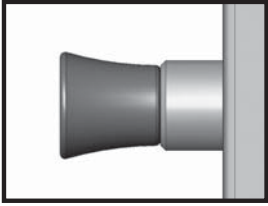

Note: Before starting any exercise or after completing any height adjustment of the carriage assembly, verify that the pull pin is fully engaged prior to use.

CABLE CROSSOVER FLY

Muscles Exercised: Pectoralis Major, Anterior Deltoid

Setup: Position the pulleys at a mid to high position with the handles at chest level. Take an overhand grip on the handles. Place one foot back for support. Keep chest out and back straight.

Performing the Exercise: Begin with the handles at chest level and arms spread apart and elbows slightly bent. With a controlled motion, squeeze the handles together in front of the body until handles nearly touch at waist height. Slowly return to the beginning position.

CABLE CROSSOVER REVERSE FLY

Muscles Exercised: Posterior Deltoid

Setup: Position the pulleys at a mid to high position with the handles at shoulder level. Take an overhand grip on the handles (left side in right hand and right side in left hand). Stand upright and centrally in gym with pulleys in front of the body.

Performing the Exercise: Begin with the handles at shoulder level, arms crossed directly in front of the body and elbows slightly bent. With a controlled motion, pull hands backward in an arc, parallel to the floor. Stop when arms are extended to the sides of the body at shoulder height. Slowly return to the beginning position.

6. MAINTENANCE PROCEDURES

MAINTENANCE SCHEDULE

ACTION	DAILY	WEEKLY	MONTHLY	AS NEEDED
CLEAN				
Upholstery	X			
Guide Rods			X	
Shrouds			X	
Hand Grips				X
WAX				
Frames				X
INSPECT				
Paint			X	
Cable	X			
Hardware		X		
Frame		X		
Hand Grips		X		
Shrouds	X			
LUBRICATE				
Guide Rods				X

CLEAN...

1. Upholstery with a mild soap and water.
2. Guide Rods with a cotton cloth.
3. Hand Grips with mild soap and water.

WAX...

1. Frames with a standard, non-abrasive, wax finish.

INSPECT...

1. Cables. Look for wear or damage and proper tension. Pay close attention at bends and attachment points.
2. Hardware. Check for loosening. Tighten as required.
3. Frames. Inspect for wear and damage.
4. Handgrips. Check for wear and damage.
5. For paint chips. Fill in immediately with Life Fitness touch-up paint.

LUBRICATE

Lubricate guide rods with Break-Free® brand lubricant (part number SK50-P0005-0000). Apply the lubricant to a cotton cloth, and then run the cotton cloth up and down the guide rods as needed.

Note: only a few drops of lubricant are required for each guide rod.

ONCE A DAY

1. Wipe down upholstery with a mild soap and water or comparable all purpose cleaner. Do not use any cleaner that contains bleach, ammonia, or alcohol on the upholstery.
2. Visually inspect cables for wear at and around connections and along the entire length of the cable. Always replace at first sign of wear.

ONCE A WEEK

1. Visually inspect all hardware for loosening, tampering or wear.
2. Check Jam Nut at top of weight stack for tightness.
3. Inspect all accessories, connecting links, and carabiner clips for wear.
4. Check condition of hand grips.
5. Check cables for stretch and adjust as necessary by loosening the large Jam Nut on top of the weight stack and by screwing in the Threaded Plug until cable is tight and the weight stack pin goes in all holes easily.
6. Inspect Shrouds for damage and clean as necessary.

ONCE A MONTH

1. Clean Guide Rods with Break-Free® brand lubricant (part number SK50-P0005-0000). Clean tops of bearings at stack and inspect for heavy buildup on rods below the head plate. Lift half of stack and do a visual inspection, then clean as necessary.
2. Inspect hardware on all machines and tighten any bolts or nuts that may have loosened over the life of the product.

NOTES

Use polishing compound (such as car wax) and remove shoe scuffs from powder coated surfaces as necessary.

CLEANING THE SHROUDS

Adherence to regular and proper cleaning procedures is recommended to preserve the appearance.

MINIMIZE SCRATCHES

Wash the shrouds with a mild soap or detergent (e.g. Original Dawn® Dishwashing Liquid) and luke-warm water using a clean sponge or a soft cloth. Rinse well with clean water. Dry thoroughly with a chamois or moist cellulose sponge to prevent water spots. Do not scrub or use brushes on the shrouds.

Fresh paint splashes, grease and smeared glazing compounds can be removed easily before drying by rubbing lightly with isopropyl alcohol. Afterward, a warm final wash should be made, beginning with a mild soap or detergent solution and ending with a thorough rinsing with clean water.

LIFE FITNESS APPROVED CLEANERS

Two preferred cleaners have been approved by Life Fitness reliability experts: PureGreen 24 and Gym Wipes. Both cleaners will safely and effectively remove dirt, grime and sweat from equipment. PureGreen 24 and the Antibacterial Force formula of Gym Wipes are both disinfectants that are effective against MRSA and H1N1.

PureGreen 24 is available in a spray which is convenient for gym staff to use. Apply the spray to a microfiber cloth and wipe down the equipment. Use PureGreen 24 on the equipment for at least 2 minutes for general disinfection purposes and at least 10 minutes for fungus and viral control.

Gym Wipes are large, durable pre-moistened wipes to use on the equipment before and after workouts. Use Gym Wipes on the equipment for at least 2 minutes for general disinfection purposes.

Contact Customer Support Services to order these cleaners (1-800-351-3737 or email: customer-support@lifefitness.com).

LIFE FITNESS COMPATIBLE CLEANERS

Mild soap and water or a mild non-abrasive household cleaner can also be used to clean the display and all exterior surfaces. Use a soft cotton cloth only. Apply the cleaner to the cotton cloth before cleaning. DO NOT use ammonia or acid based cleaners. DO NOT use abrasive cleaners. DO NOT use paper towels. DO NOT apply cleaners directly to the equipment surfaces.

REMOVAL OF PAINT, MARKING PEN AND LABELS

Butyl cellosolve works well for removal of paints, marking pen inks, lipstick, etc. Labels, stickers, etc. may be removed using kerosene. When the solvent will not penetrate sticker material, apply heat (hair dryer) to soften the adhesive and promote removal. **GASOLINE SHOULD NOT BE USED.**

IMPORTANT HAZARDS

1. DO NOT use abrasive or highly alkaline cleaners.
2. NEVER scrape equipment with squeegees, razor blades or other sharp instruments.
3. DO NOT clean equipment in hot sun or at elevated temperatures.
4. NEVER use benzene, gasoline, acetone or carbon tetrachloride.

© 2011. Life Fitness, a division of Brunswick Corporation. All rights reserved.

Printed in the United States of America.

Life Fitness World Headquarters

5100 N. River Rd.

Schiller Park, IL 60176

www.lifefitness.com

800-735-3867