

Owner's Manual

GREEN Series



CIR-TM7000E-G1

Full Commercial Treadmill



Full Commercial



Light Commercial



Install Date: _____

Serial Number: _____

www.GreenSeriesFitness.com

©April 2017
CIR-TM7000E-G1 Revision 1.1

Call Toll free at (800) 269-7130

TABLE OF CONTENTS

SAFETY PRECAUTIONS	2-8
Important voltage information, grounding instructions, how often you exercise, how hard you exercise, how long you exercise, beginner treadmill program, target heart rate zone.	
TECHNICAL SPECIFICATIONS	9
UNPACKING & ASSEMBLY	10-17
Parts, hardware kit and assembly drawing	
WARM UP & COOL DOWN	18
SETTINGS	19
WiFi and TV Settings	
PROGRAMS	20-31
Control panel function and programs	
OPERATION	32-34
BELT ADJUSTMENT	35
CARE & MAINTENANCE	36-37
TROUBLESHOOTING	38-39
PARTS LIST	40-41
EXPLODED DRAWINGS	42-44
WARRANTY	45-47

SAFETY PRECAUTIONS

Location of the Treadmill

Before assembling the unit, verify the chosen site meets the following criteria:

- Area is well lit and well ventilated.
- Surface is structurally sound and properly leveled.
- Free area for access to the unit and emergency dismount. Minimum clearance is 24 inches (0.6 meters) on the sides of the unit and 78.7 inches (2.0 meters) behind the unit.
- Adjacent units may share the free area.
- Place in a location away from direct sunlight. The intense UV light can cause discoloration on the plastics.
- Locate your treadmill in an area with cool temperatures and low humidity.
- Do not install, use or store the treadmill in an area of high humidity, such as in the vicinity of a steam room, sauna, indoor pool, garage, covered patio, near water or outdoors. Exposure to extensive water vapor, chlorine and/or bromine could adversely affect the electronics as well as other parts of the unit.

The below minimum spacing recommendations are based on a combination of the ASTM (U.S.) voluntary standards and EN (European) regulations as of October 1, 2012, for access, passage around, and emergency dismount:

ASTM standards are voluntary and may not reflect current industry standards. The actual area for access, passage around, and emergency dismount is the responsibility of the facility. The facility should consider the total space requirements for training on each unit, voluntary and industry standards, and any local, state, and federal regulations. Standards and regulations are subject to change at any time.

Careful consideration should be given to the requirements of the Americans with Disabilities Act (ADA), US Code 28 CFR (see Section 305).

In compliance with the ADA (American Disabilities Act) there must be clear floor space of at least 30 inches by 48 inches and be served by an accessible route for at least one of each type of exercise equipment. If the clear space is enclosed on three sides (e.g., by walls or the equipment itself), the clear space must be 36 inches by 48 inches.

Important: These spacing recommendations should be used when positioning equipment away from sources of heat, such as radiators, heat registers, and stoves. Avoid temperature extremes.

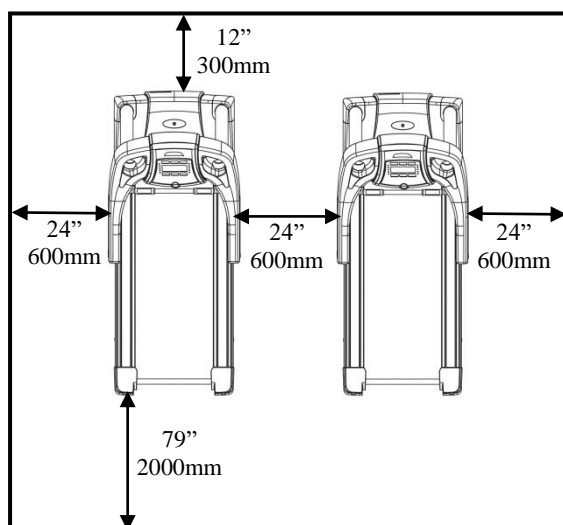

SAFETY PRECAUTIONS

Environment

The unit is designed to function normally in an environment with a relative humidity range of 30% to 75%. The unit can be shipped and stored in a relative humidity range of 10% to 90%. Climatic dry air may cause static electricity. During a workout, a user may experience a shock due to a buildup of static electricity on the body and the discharge path of the unit. If static electricity is experienced, increase humidity to a comfortable level through the use of a humidifier.

Temperature

The unit is designed to function in an environment with an ambient temperature range of 50°F (10°C) to 104°F (40°C). The unit can be shipped and stored in an environment with an ambient temperature range of 32°F (0°C) to 140°F (60°C).

Electrical Power Requirements

The power requirements for this treadmill are a grounded, dedicated circuit rated for the following:

- 115 VAC, 50/60 HZ, 20A



Shock and electrocution hazard.

- Connect unit to a grounded outlet.
- Do not use a voltage adapter or extension cord.

• Important Voltage Information

- Before plugging the power cord into an electrical outlet, verify that the voltage requirements for your area match the voltage of the treadmill that you have received. The power requirements for the treadmill include a grounded, dedicated circuit, rated for one of the following figure. See the serial number decal for the exact voltage requirements of your treadmill.
- **WARNING: Don't attempt to use this unit with an unapproved voltage adapter. All voltage adapters **MUST** be approved and supplied by Green Series Fitness prior to use.**
- Don't attempt to use this unit with an extension cord which does not meet Green Series Fitness criteria of the following; 12 gauge SO3, maximum of 25 foot length with a 20 amp rating.

Grounding Instructions

This equipment must be grounded. If it should malfunction or break down, grounding provides a path of least resistance for electric current to reduce the risk of electric shock.

This equipment is equipped with a cord having an equipment-grounding conductor and a grounding plug. The plug must be plugged into an appropriate outlet that is properly installed and grounded in accordance with all local codes and ordinances. Please make sure that the equipment is connected to an outlet having the same configuration as the plug. Do not use a ground plug adapter to adapt the power cord to a non-grounded outlet.

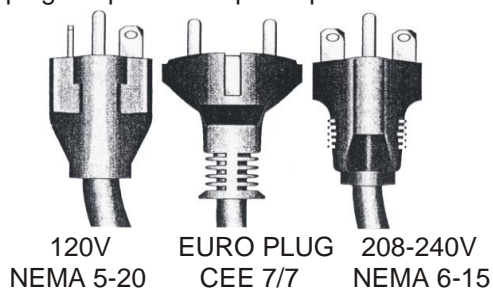

The power requirements for the equipment includes a grounded, dedicated circuit, rated for one of the following:

- 120 VAC 5%, 60HZ and 20 amps;
- 208/240 VAC, 60HZ, 15 amps
- 240 VAC 5%, 50HZ and 15amps.

SAFETY PRECAUTIONS

Waste Disposal

Products are recyclable. At the end of its useful life please dispose of this article correctly and safely (local refuse sites).



- The running belt must be set up on firm even ground. Ensure that the power cable is not pinched and that no one can trip over it.
- Never touch the moving belt with your hands. Also ensure that there are no objects close to the belt or the rollers which could be pulled into it thus causing injury or damaging the unit itself.
- Repairs on the electrical components in the unit should be carried out by qualified persons only.
- The treadmill has an emergency stop mechanism for your safety. Before starting your workout, fasten the cord of the safety key to your clothing. If the treadmill has been shut down by removing the safety key, restart it by reinserting the key. An automatic restart of the treadmill belt does not occur. Further instructions concerning the handling of the safety cut-out can be found in the operating instructions for the training computer.

Thank you for your purchasing our products. Even though we go to great efforts to ensure the quality of each product, occasional error, and/or omissions do occur. In any event should you find this product to be defective or missing parts please contact us.

IMPORTANT: Read all instructions and warnings before assembly and operation.

IMPORTANT SAFETY INSTRUCTIONS

When using equipment, basic precautions should always be followed, including the following:
Read all instructions before using the Treadmill.

DANGER - To reduce the risk of electric shock: Always unplug this appliance from the electrical outlet immediately after using and before cleaning.

WARNING - To reduce the risk of burns, fire, electric shock, or injury to persons:

1. The equipment should never be left unattended when plugged in. Unplug from outlet when not in use and before putting on or taking off parts.
2. Close supervision is necessary when the equipment is used by, on, or near children, invalids, or disabled persons.
3. Use the equipment only for its intended use as described in this manual. Do not use attachments not recommended by the manufacture.
4. Never operate the equipment if it has a damaged cord or plug, if it is not working properly, if it has been dropped or damaged, or dropped into water. Return the equipment to a service center for examination and repair.
5. Do not carry the equipment by supply cord or use cord as a handle.
6. Keep the cord away from heated surfaces.
7. Never operate the equipment with the air openings blocked. Keep the air openings free of lint, hair, and the like.
8. Never drop or insert any object into any opening.
9. Do not use outdoors.
10. Do not operate where aerosol (spray) products are being used or where oxygen is being administered.
11. To disconnect, turn all controls to the **OFF** position, then remove plug from outlet.
12. Connect the equipment to a properly grounded outlet only. See Grounding Instructions.
13. The equipment is intended for commercial use.
14. Store the safety key in a secured location while not in use and keep away from children.
15. Maximum user weight: 450lbs (204 kg) .

SAFETY PRECAUTIONS

EMERGENCY DISMOUNT:

In case you must leave the equipment in an EMERGENCY SITUATION, grab the handrail and set both feet on the right and left foot platform beside the running belt. Now you pull out the safety switch, in order to slow down the equipment.

The function of the immobilization method:

If you would like to stop the equipment, then you can stop it either with the switch on the console or pull out the safety switch. If you pull the safety switch, in this case the computer shut down all functions automatically and the running belt slow down immediately.

SAFETY KEY

Check if the safety key at the console and the clip at your clothes are secured. The safety key is intended for interrupting the main connection in case you should fall. Thus, it was developed to bring the equipment to an immediate stop. For higher speeds this can be unpleasant and somewhat dangerous as well. Please only use the safety key for an emergency stop. In order to stop the equipment during training under normal circumstances in a safe, comfortable and complete manner, use the **STOP** button.

ENTER AND LEAVE THE TREADMILL

Be careful when entering and leaving the treadmill. Use the handle bars. Do not position yourself on the treadmill when preparing the use. Spread your feet and put them on the two side platforms next to the running surface. Put your feet on the treadmill only if it has started moving at constant speed. For your own safety, only enter the treadmill if it is not running faster than 2 km/h. Always look to the front during the training sessions. Never try to turn around on the treadmill as long as the treadmill is activated. After having finished your training session, you can stop the treadmill by pressing the **STOP** button. Wait until the treadmill has stopped completely before trying to leave the treadmill. In case you feel unsure regarding the speed you should hold on to the handle bars, lift your feet from the treadmill, and position yourself on the side platforms next to the running surface. These side platforms are an appropriate position to relax before starting the training again. For your own safety and comfort, always start your training sessions at low speed.

CONSULT A PHYSICIAN IMMEDIATELY

Warning: before starting any exercise program consult your physician. This is especially important for individuals over the age of 35 or persons with preexisting health problems. Read all instructions before using any fitness equipment. We assume no responsibility for personal injury damage sustained by or through the use of this treadmill.

How often you exercise:

You should exercise three to four times a week to improve your cardiovascular and muscle fitness.

How hard you exercise:

Intensity of exercise is reflected in your heart rate. Exercise must be sufficiently rigorous to strengthen your heart muscle and condition your cardiovascular system. Only your doctor can prescribe the target training heart range for you. Before starting any exercise program consult your physician.

How long you exercise:

Sustained exercise conditions your heart, lungs and muscles. The longer you are able to sustain exercise within your target heart range, the greater the aerobic benefits. To begin maintain 2~3 minutes of steady, rhythmic exercise, then check your heart rate.

Safety key

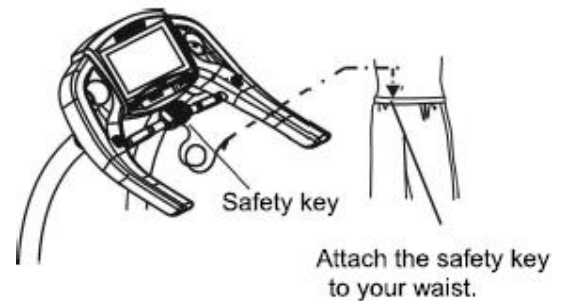

SAFETY PRECAUTIONS

EMERGENCY DISMOUNT:

In case you must leave the equipment in an **EMERGENCY SITUATION**, grab the handrail and set both feet on the right and left foot platform beside the running belt. Now you pull out the **SAFETY KEY** from the console to slow down and stop the equipment.



Attach the safety key to your waist.

The function of the immobilization method:

If you would like to stop the equipment, then you can stop it either with the **STOP** switch on the console or pull out the **SAFETY KEY** from the console. If you pull the **SAFETY KEY** from the console, this case the computer shut down all functions automatically and the running belt slow down and come to a stop immediately.

SAFETY KEY

Check if the **SAFETY KEY** at the treadmill and the clip at your clothes are secured. The **SAFETY KEY** is intended for interrupting the mains connection in case you should fall. Thus, it was developed to bring the treadmill to an immediate stop. For higher speeds this can be unpleasant and somewhat dangerous as well. Please only use the **SAFETY KEY** for an emergency stop. In order to stop the treadmill during training under normal circumstances in a safe, comfortable and complete manner, use the **STOP** button.

ENTER AND LEAVE THE TREADMILL

Be careful when entering and leaving the treadmill. Use the handle bars. Do not position yourself on the treadmill when preparing the use. Spread your feet and put them on the two side platforms next to the running surface. Put your feet on the treadmill only if it has started moving at constant speed. For your own safety, only enter the treadmill if it is not running faster than 2 km/h. Always look to the front during the training sessions. Never try to turn around on the treadmill as long as the treadmill is activated. After having finished your training session, you can stop the treadmill by pressing the **STOP** button. Wait until the treadmill has stopped completely before trying to leave the treadmill. In case you feel unsure regarding the speed you should hold on to the handle bars, lift your feet from the treadmill, and position yourself on the side platforms next to the running surface. These side platforms are an appropriate position to relax before starting the training again. For your own safety and comfort, always start your training sessions at low speed.

SAFETY PRECAUTIONS

CONSULT A PHYSICIAN IMMEDIATELY

Warning: before starting any exercise program consult your physician. This is especially important for individuals over the age of 35 or persons with preexisting health problems. Read all instructions before using any fitness equipment. We assume no responsibility for personal injury damage sustained by or through the use of this treadmill.

How often you exercise:

You should exercise three to four times a week to improve your cardiovascular and muscle fitness.

How hard you exercise:

Intensity of exercise is reflected in your heart rate. Exercise must be sufficiently rigorous to strengthen your heart muscle and condition your cardiovascular system. Only your doctor can prescribe the target training heart range for you. Before starting any exercise program consult your physician.

How long you exercise:

Sustained exercise conditions your heart, lungs and muscles. The longer you are able to sustain exercise within your target heart range, the greater the aerobic benefits. To begin maintain 2~3 minutes of steady, rhythmic exercise, then check your heart rate.

Emergency Stop switch

The function of the **EMERGENCY STOP** is to help the user to get off the treadmill safely in case of an emergency. In case of emergency, press the **STOP** key, hold the handrails and get off when the belt stops.

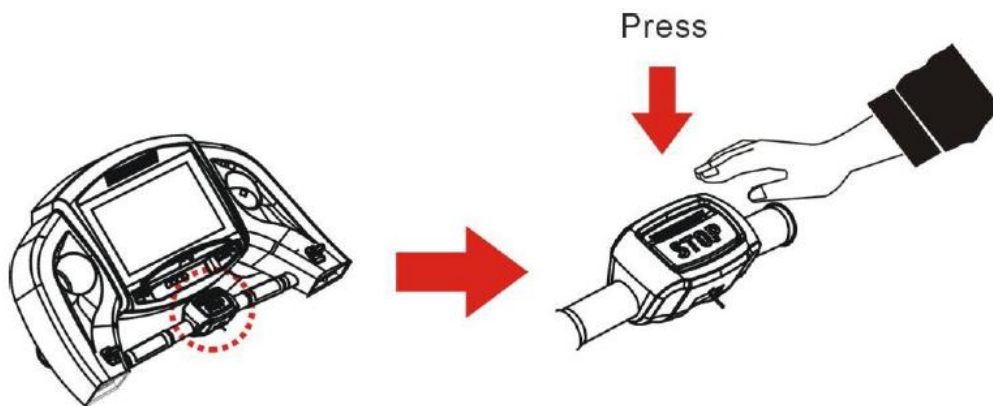

SAFETY PRECAUTIONS

BEGINNER TREADMILL PROGRAM

	EXERTION LEVEL	DURATION
WEEK 1	Easy	6~12 minutes
WEEK 2	Easy	10~16 minutes
WEEK 3	Moderate	14~20 minutes
WEEK 4	Moderate	18~24 minutes
WEEK 5	Moderate	22~28 minutes
WEEK 6	Slightly higher or slightly lower	20 minutes
WEEK 7	Add interval training	3 minutes at moderate exertion with 3 minutes at higher exertion for 24 minutes

TARGET HEART RATE ZONE

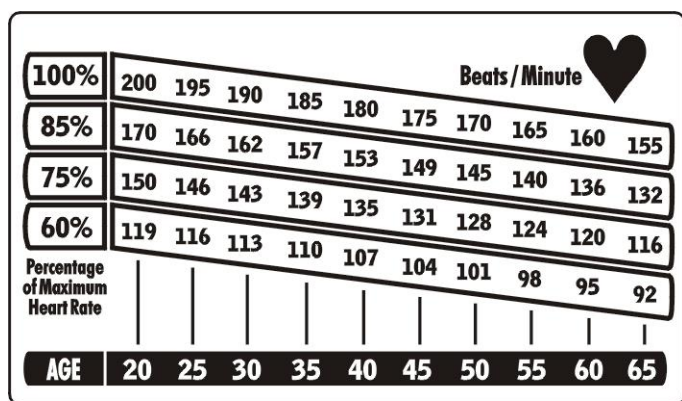

You do not want to workout at your maximum heart rate. The recommended Heart Rate Zone is a percentage of your maximum heart rate. Between 65% and 80% of your maximum heart rate.

* Lower limit of Target Heart Rate Zone
=maximum heart rate X 0.6

* Upper limit of Target Heart Rate Zone
=Maximum heart rate X 0.8

(This is recommended by American Heart Association. Before starting exercise program, please consult your physician to understand your physical situation)

- 100%** Increased Performance Range
- 85%** Aerobic Training Range
- 75%** Weight Loss Training Range
- 60%** Heart Rate BPM

220-your age = maximum heart zone

1* Advantage of using the treadmill is consumers can strengthen the cardiopulmonary function and physical fitness.

*This appliance is not intended for use by persons (including children) with reduced physical sensory or mental capabilities, or lack of experience and knowledge, unless they have been given supervision or instruction concerning use of the appliance by a person responsible for their safety.

*The noise value list below is when it is at top speed with unloading status :

$$LpAeq(dB) < 70dB$$

TECHNICAL SPECIFICATIONS

The Serial Number Location

The serial number contains ten values. The location of the serial number shows as in the figure below.



SPECIFICATIONS:

Length: 83" (215 cm)

Width: 36" (92 cm)

HEIGHT: 57" (145 cm)

Running area: 22" x 60" (55cm x 154cm)

Weight of product: 363 lbs (165 kg)

Speed Range: 0.3 to 15.5 mph (0.48 to 25 km)

Power elevation: 0~18% motorized (front incline)

Emergency stop: Pull the safety key, press emergency stop switch.

Programs: 9 preset programs, 4HRC.

Manual mode: Yes

Standard features: Time Remaining, Time Elapsed, Speed, Incline, Heart Rate, Maximum Heart Rate, Average Heart Rate, Distance, Calories, Calories/h, Program Profile, Pace Average, Pace, Wireless HR receiver.

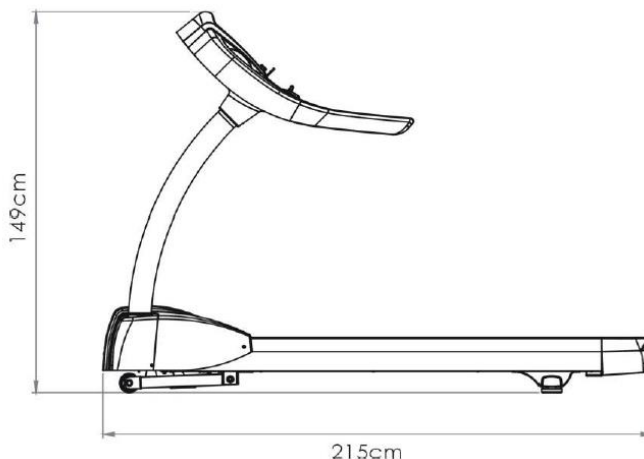
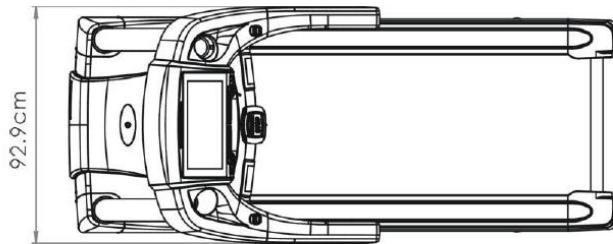

UNPACKING & ASSEMBLY

PARTS

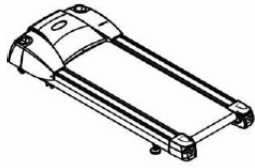

Main body



Console

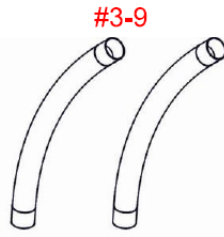

Console mast set

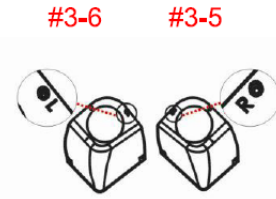

Left console mast cover
(Packing via transparent bag)

Right console mast cover



Packing

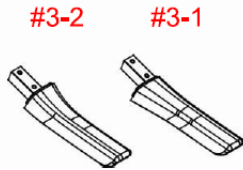



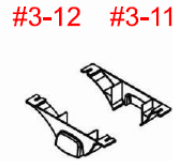





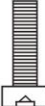

Handlebar set
(Left Handlebar with transparent bag)

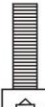

Adjustable pad cover

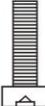
UNPACKING & ASSEMBLY

HARDWARE KIT

Step 2	<p>#3-3</p>  <p>M8X25mm / 10pcs</p>	<p>#3-14</p>  <p>M8 S Washer / 10pcs</p>	<p>#3-4</p>  <p>M8 Washer / 10pcs</p>
Step 4	<p>#3-3</p>  <p>M8X25mm / 8pcs</p>	<p>#3-14</p>  <p>M8 S Washer / 8pcs</p>	<p>#3-4</p>  <p>M8 Washer / 8pcs</p>
Step 5	<p>#3-7</p>  <p>M5x15mm / 4pcs</p>		
Step 6	<p>#3-3</p>  <p>M8X25mm / 4pcs</p>	<p>#3-14</p>  <p>M8 S Washer / 4pcs</p>	<p>#3-4</p>  <p>M8 Washer / 4pcs</p>
Step 7	<p>#3-18</p>  <p>M3x12mm / 1pc</p>		

#3-15

 End cap / 4pcs
 (Lower console cover)

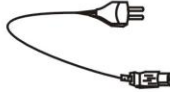
X1



 Allen wrench /
 1pcs (5mm)

 Allen wrench /
 1pcs (6mm)

#3-17

 Power cord locker
 / 1pc (Power cord)

 Cable Connector
 /1pcs

UNPACKING & ASSEMBLY

IMPORTANT: Read all instructions and warnings before assembly and operation.

***This unit has been 100% assembled, tested for all functions including vibration sensors and then disassembled.* Any misalignments causing stripped out threads is not covered by warranty due to installer not reinstalling correctly per the following steps #1 thru #7.**

Unpacking your treadmill where will be using it. Being careful not to damage. Place your treadmill on a level flat surface. It is recommended that you place a protective covering on your floor.

*Notice: Because of heavy weight, please assemble this treadmill more than two people.

Step 1: Remove the motor cover screws, and put the motor cover aside.

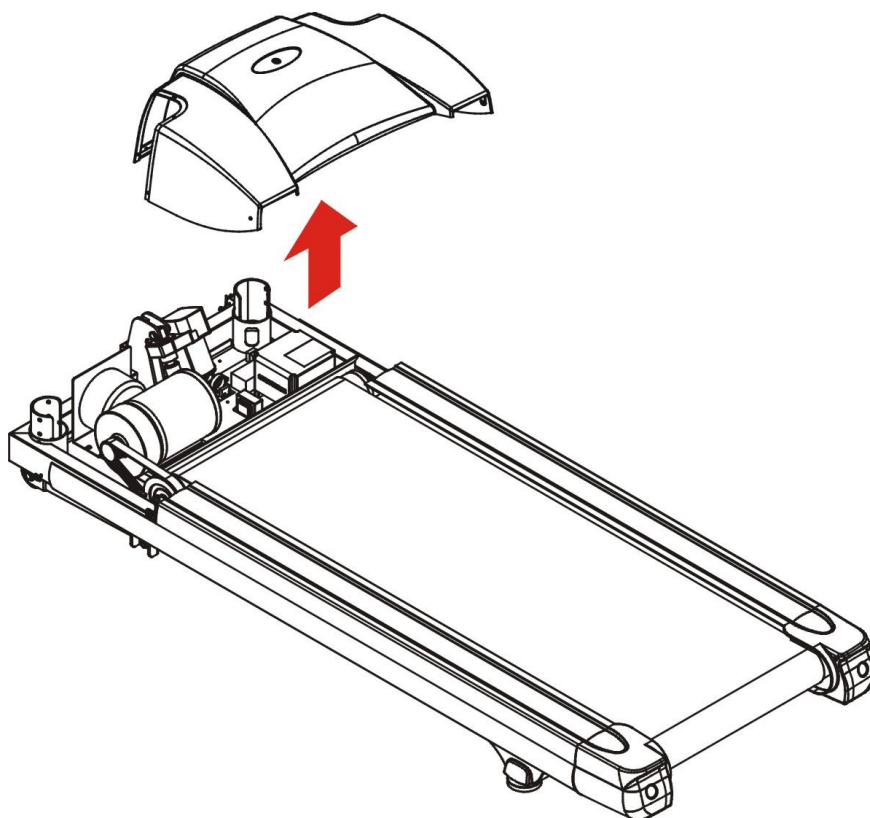

UNPACKING & ASSEMBLY

Step 2: Assemble the Console Mast to the Base

WARNING: The tightening sequence **MUST** be adhered to when performing assembly.

- 1) Place the CONSOLE WIRE into the RIGHT MAST and secure to the GUIDE WIRE which is attached to the bottom of the RIGHT MAST. Pull the CONSOLE WIRE through the RIGHT MAST from the top using the GUIDE WIRE. Once the CONSOLE WIRE has been pulled through the RIGHT MAST, carefully place the RIGHT MAST into the console mast support tube on the treadmill. (The LEFT MAST is in the transparent bag.)
- 2) Secure the LEFT and RIGHT MASTS using (10) M8x15mm bolts (#3-8) and (10) M8 curve washers (#3-15).
(Hand tighten the (10) M8x15mm bolts. Final tightening will occur in Steps 4.5 through 4.7).

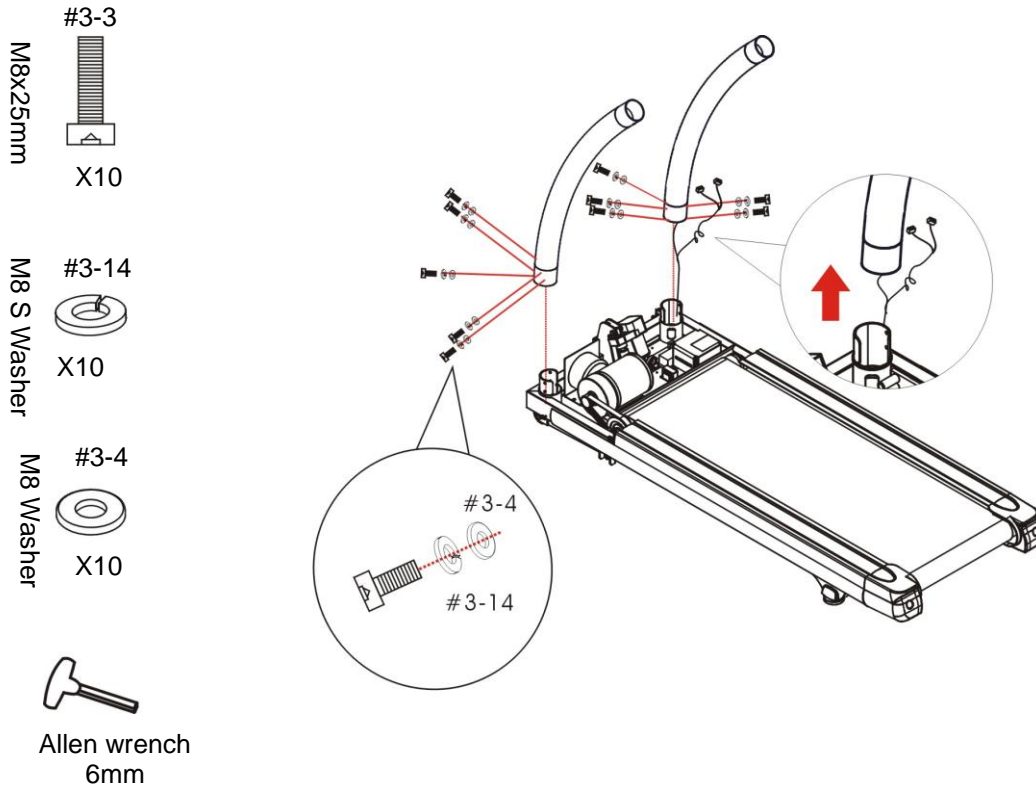

Step 3: Set Mast Covers onto Masts.

1. Slide the CONSOLE MAST COVERS (#3-5, #3-6) and (2) PACKING (#3-8) onto the LEFT and RIGHT CONSOLE MASTS.

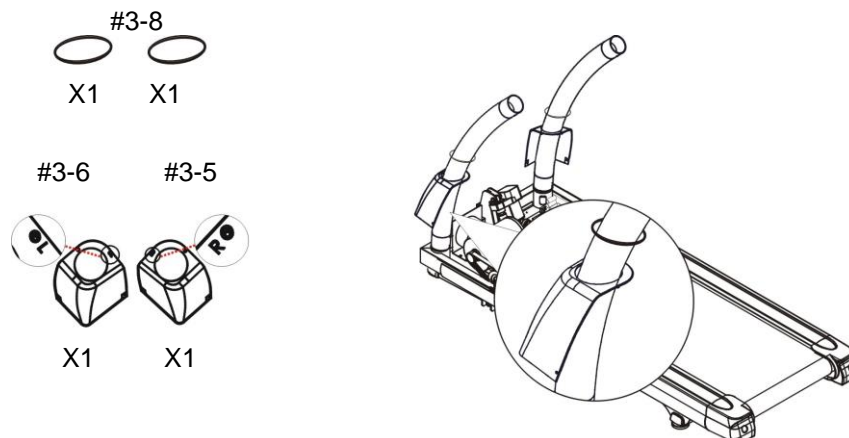

UNPACKING & ASSEMBLY

Step 4: Attach Console to the Console Masts.

1. Remove the GUIDE WIRE with the attached CONSOLE WIRE from the RIGHT CONSOLE MAST. Connect the CONSOLE CABLE to the CONSOLE.
2. Place the CONSOLE onto the LEFT and RIGHT CONSOLE MASTS.
3. Using a 5mm Hex wrench, attach and secure the CONSOLE to the CONSOLE MASTS with (8) M8x25mm bolts (#3-3), (8) S washers (#3-14) and (8) flat washers (#3-4).
4. Place (4) END CAPS (#3-15) into the CONSOLE lower cover.
5. Using a 6mm Hex wrench, tighten and secure the (10) M8x15mm bolts on the RIGHT and LEFT CONSOLE MASTS to the BASE FRAME.
6. Hike on the treadmill, facing the console, lift up and down vigorously on the handles with 50 to 100 pounds of force several times.

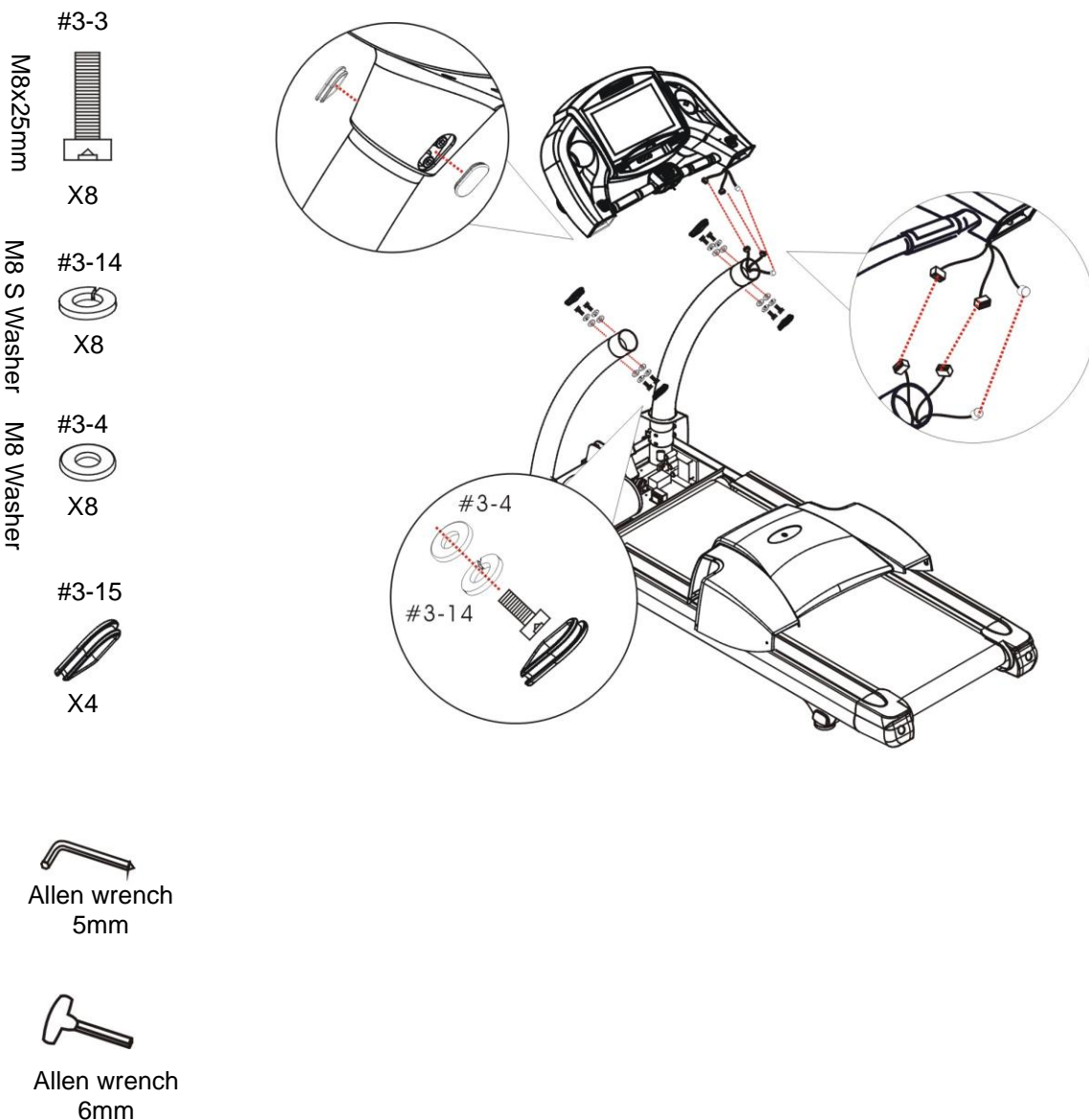

UNPACKING & ASSEMBLY

7. Using a Torque wrench set to **20 ft/lbs**, tighten (8) (#3-17) bolts labeled “**A**”. The remaining (2) bolts (#3-17) located on the front of the console mast tubes, labeled “**B**”, shall be torqued to **15 ft/lbs**. Verify that the console mast is secure and tight by lifting up and down vigorously on the handles with 50 to 100 pounds of force several times. If needed, re-torque to the specifications outlined.

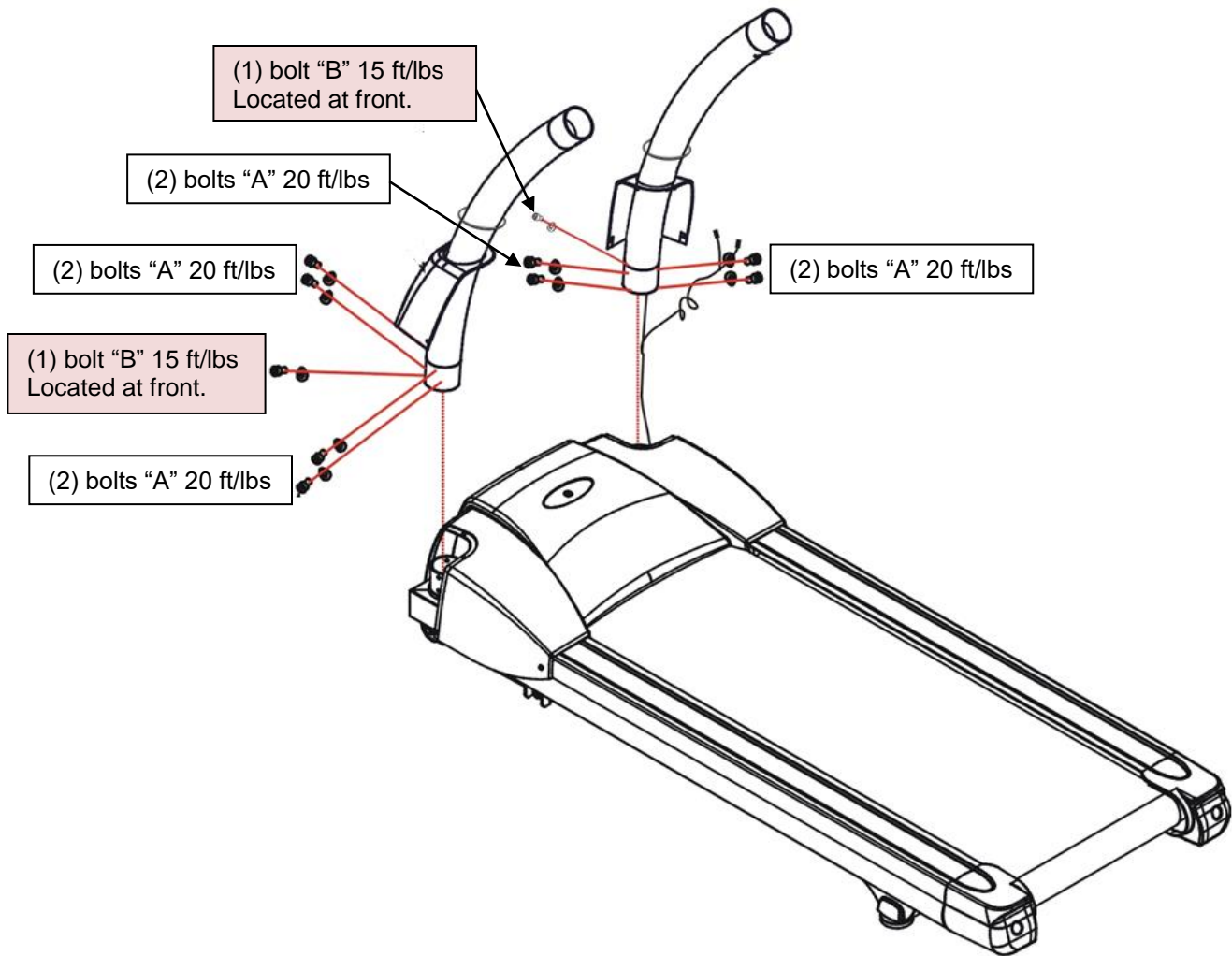

UNPACKING & ASSEMBLY

Step 5: Installing the Console Mast Covers

1. Install the MOTOR COVER onto the base frame and secure in place with the provided screws.
2. Slide the CONSOLE MAST COVERS and the PACKING down and secure in place using a Phillips screwdriver and the (4) M5x15mm screws.

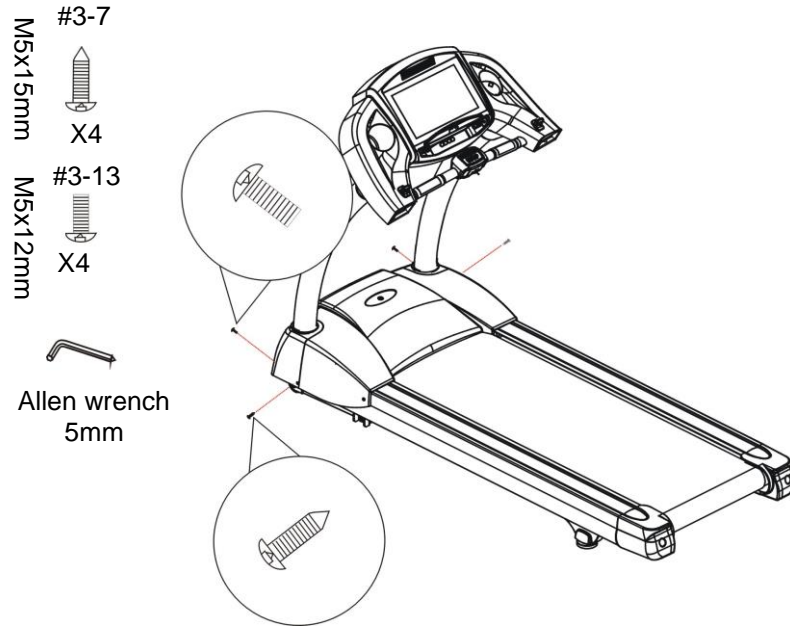

Step 6: Assembling the Handle Bars to the Console.

1. Slide handlebar onto console, using an Allen wrench, install the (4) bolts M8x25mm and (4) M8 S washers and (4) M8 flat washers.
2. Using a Torque wrench set to **20 ft/lbs**, tighten the (4) bolts M8x25mm.
3. Verify that the Shifter paddles move freely. If the paddles bind, loosen the (4) bolts, M8x25mm, re-align the handlebars and then re-torque the (4) bolts to **20 ft/lbs**.

Ensure that there is no gap occurring between the handlebars and the console assembly. It may be necessary to loosen the bolts attaching the handlebars to the console and adjust accordingly until a gap is not present. Once there is no gap in the assembly, fully tighten the (4) bolts securing the handlebars.

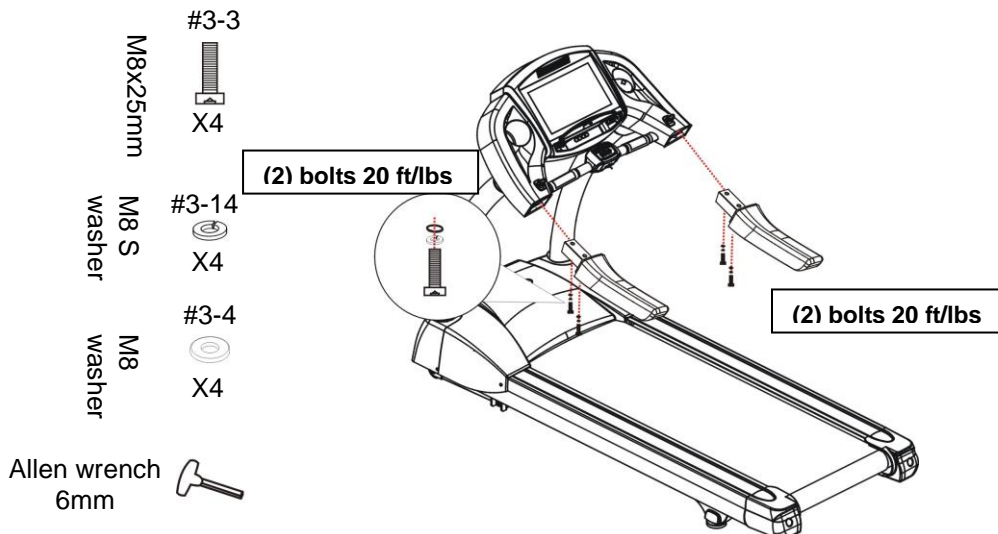

UNPACKING & ASSEMBLY

Step 7: Assembly power cord locker and power cord.

- 1). Plug in the power cord.
- 2). Using a Phillips head screw driver, remove (1) existing M3 screw from the right side of the power cord receptacle.
- 3). Insert the power cord and power cord locker (#3-19). Using Phillips head screw driver, install (1) M3x12mm (#3-20) screw to the right side of the power cord receptacle to secure the power cord locker.

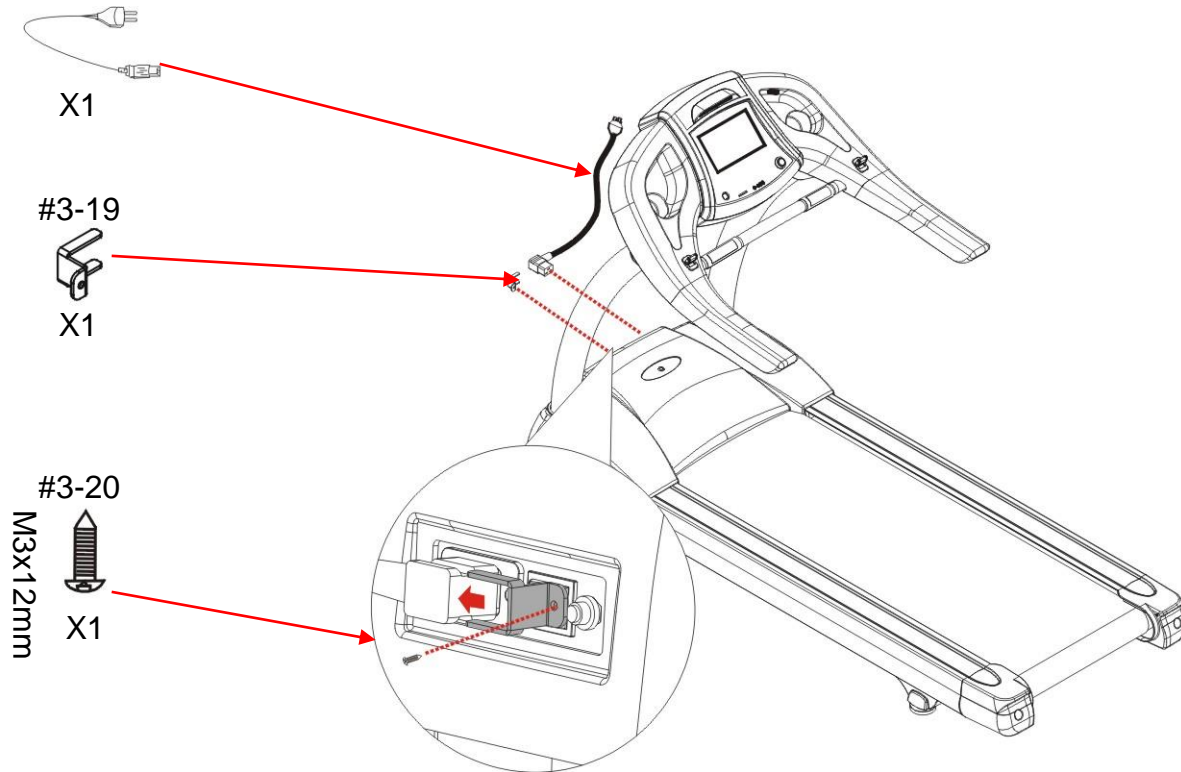

WARM UP & COOL DOWN

A successful exercise program consists of a warm up, aerobic exercise and a cool down. Warming up is an important part of your workout, and should begin every session. It prepares your body for more strenuous exercise by heating up and stretching out your muscles. At the end of your workout, repeat these exercises to reduce sore muscle problems. We suggest the following warm-up and cool-down exercises:



HEAD ROLLS

Rotate your head to the right for one count, feeling the stretch up the left side of your neck. Next rotate your head back for one count, stretching your chin to the ceiling and letting your mouth open. Rotate your head to the left for one count, and finally, drop your head to your chest for one count. Repeat this action for several times.



SHOULDER LIFTS

Lift your right shoulder up toward your ear for one count. Then lift your left shoulder up for one count as you lower your right shoulder. Repeat this action for several times.



QUADRICEPS STRETCH

With one hand against a wall for balance, reach behind you and pull your right foot up. Bring your heel as close to your buttocks as possible. Hold for 15 seconds and repeat with left foot up.



SIDE STRETCHES

Open your arms to the side and continue lifting them until they are over your head. Reach your right arm as far upward toward the ceiling as you can for one count. Feel the stretch up your right side. Repeat this action with your left arm.

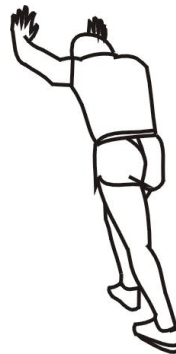

CALF/ACHILLES STRETCH

Step your right foot in front of your body. Lean against a wall with your arms and stretch your left foot backward your body. Bend forwards your right foot, and slightly push your buttock toward to the wall for 15 seconds. Repeat the action with front left foot and rear right foot for another 15 seconds.



INNER THIGH STRETCH

Sit with the soles of your feet together with your knees pointing outward. Pull your feet as close to your groin as possible. Gently push your knees toward the floor. Hold for 15 seconds. Repeat this action 3-5 times.



TOE TOUCHES

Slowly bend forward from your waist, letting your back and shoulder relax as you stretch toward your toes. Reach down as far as you can and hold for 15 seconds.



HAMSTRING STRETCHES

Keep your right leg straight and the left foot on the floor; try to stretch your right hand toward the toe, hold this posture for 15 seconds. Relax, and then repeat the action for left leg.

SETTINGS

WiFi Setting

1. Connect WiFi before using **Multimedia, Internet** or **Bulletin Board**.
2. Press the Green Series logo for 5 seconds to enter the **Engineering Mode**. Select **Ethernet** and choose **Enable WiFi: ON**. Press **SCAN** to scan for available networks. Enter the **PASSWORD** then press **APPLY** to connect. The Status column will show connection status.

TV Setting

1. Scan TV channels after connecting the TV cable.
2. Press the Green Series logo for 5 seconds to enter the **Engineering Mode**. Select **TV** and choose **MENU**. Press the **UP/DOWN** button to **AUTO TUNING** then press **OK** to start the **SCAN TV** channel.

PROGRAMS

1. Main Page :



- 1.1. The Entertainment Plus has a full integrated touch screen display. All information required for workouts is explained on screen. Programs included Quick Start/ Training Courses/Goal Training/ Heart Rate Control/ Physical Test/ Virtual Connect/ Multimedia.
- 1.2. The Entertainment Plus support FitGoal application, please free download FitGoal from Apple Store or Google Play.
- 1.3. The Entertainment Plus support Nike+: compatible iPod or i-Phone 30 Pin connector (see www.apple.com/nikeplus for more information. Before syncing your Apple device to your computer, you must first create a free Nike+ account a www.nikerunning.com and download the latest iTunes software (www.apple.com/itunes).

2. Contents:

2.1. Explanation about function:

- 2.1.1. Speed and incline adjustment: Side speed bar or incline bar to adjust speed or incline, touch the screen again and showing check mark "v" to confirm speed and incline or change by using the **UP/DOWN** button.



PROGRAMS

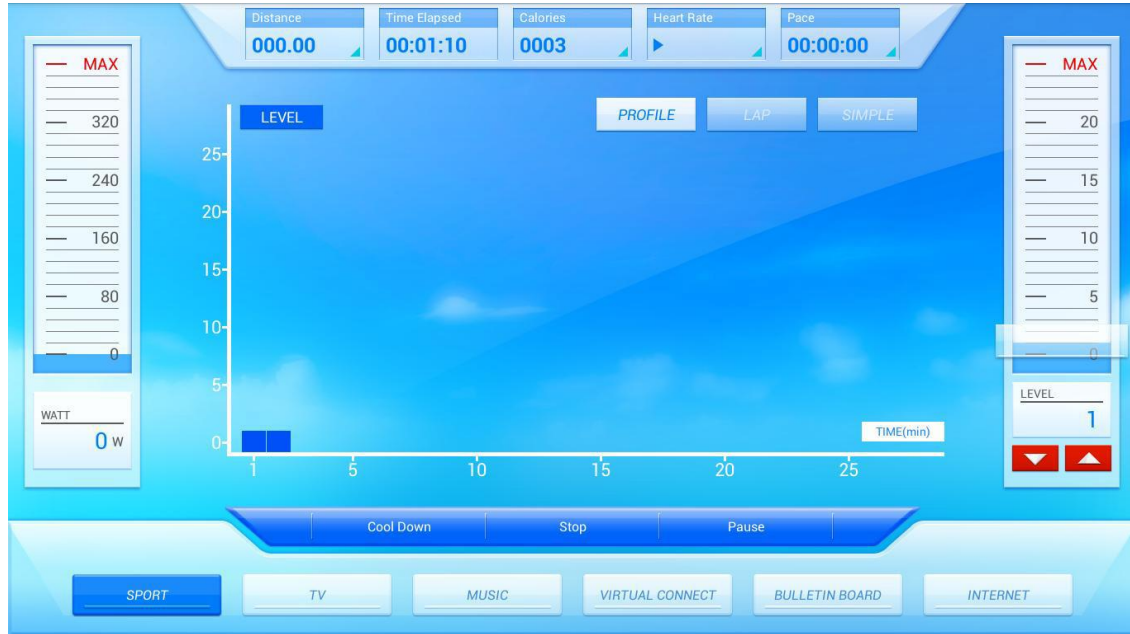

2.1.2.

Display	Function
Distance	Indicate accumulative traveled distance.
Time Elapsed	Indicate time you workout.
Time Remaining	Indicate workout time left from setting.
Calories	Indicate estimated calories burned.
Calories/ Hour	Estimated calories burned per hour
Heart Rate	Measure current heart rate.
Max Heart Rate	Indicate Max Heart Rate during workout
Ave. Heart Rate	Indicate Average Heart Rate during workout
Pace	Indicate time per km under current speed.
Best Pace	Indicate shortest time per km during workout
Ave. Pack	Indicate average time per km during workout.
Target Heart Rate	Indicate target heart rate, only showing in HRC program
Target Time	Indicate target time, only showing in Goal Training program
Target Distance	Indicate target distance, only showing in Goal Training program
Target Calories	Indicate target calories, only showing in Goal Training program

2.1.3. Display window can switch in Sport Mode: Press arrow of Display window to change information. Calories: Calories, Calories/Hour, Pace: Pace, Ave. Pace, Best Pace, Heart Rate: Heart Rate, Max Heart Rate, Ave. Heart Rate.

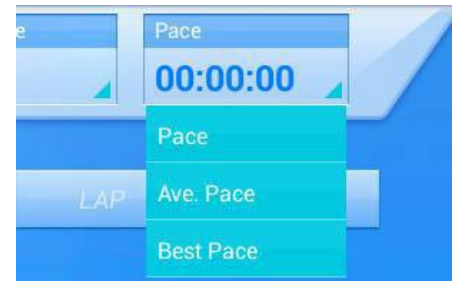
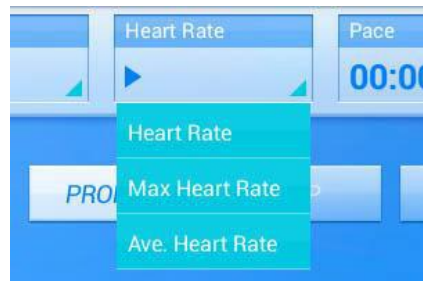
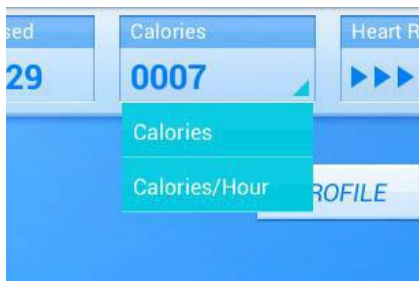

PROGRAMS

Buttons	Function
Incline ▲ / ▼	Adjust incline when exercising.
Speed + / -	Adjust running speed when exercising.
Cool Down	Puts treadmill into Cool Down mode. Cool Down time is dependent on the length of the workout. After 5 min end of cool down.
Stop	Ends workout and shows workout summary data.
Pause	Press Pause to stop temperately
Resume	Pause button change to resume after press pause
Fan	To switch off/ low/ high of the fan.
Emergency Stop/ Immobilization	To stop all functions and immobilize the unit. The emergency stop on this treadmill must be returned to its original position in order to allow normal operation of the unit.

2.1.4. Sport Mode:

2.1.4.1. PROFILE: Shows workout information and graphic.



2.1.4.2. LAP: Shows workout information via Lap.



PROGRAMS

2.1.4.3. SIMPLE: Shows simple workout information. Press arrow to change display from side to main display.

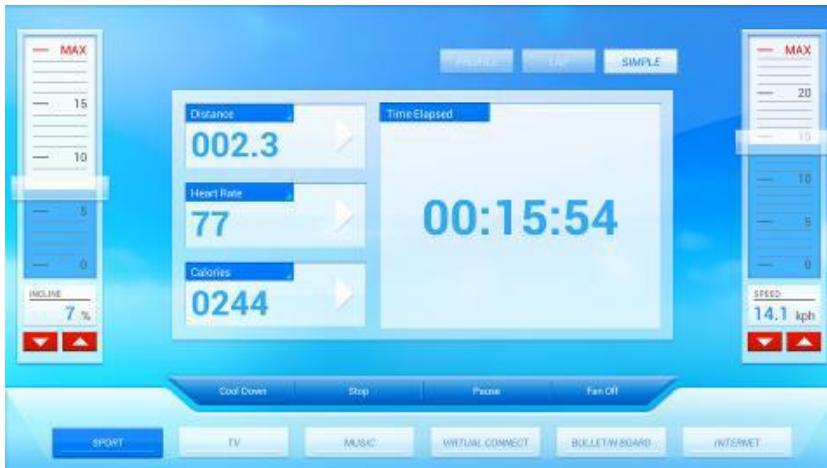

2.1.5. TV MODE:

- 2.1.5.1 CHANNEL: Allows for easy TV channel selection by NUMBER KEYPAD or CHANNEL UP/DOWN.
- 2.1.5.2. VOLUME UP/DOWN: Adjust the volume output through the headphone jock of integrated console TV or iPod output.
- 2.1.5.3. FAVORITE CHANNEL: Add or delete favorite channel into list by press STAR.
- 2.1.5.4. FULL SCREEN: Touch screen central to show FULL SCREEN.



PROGRAMS

2.1.6. MUSIC MODE: Connect smart phone or i-Pod to display your music list, select favorite music on favorite list.

Note 1. Support Apple device 30 Pin connector. Available to use transformer for 8Pin-Lightning, but some function may not able to operate.

Note 2. Few Android device do not support music select function but able to charging. Un-coded Android device before connecting.



2.1.7. VIRTUAL CONNECT: 10 virtual videos embedded. Video speed changes according to selected running speed. Press the touch screen center to display full screen or touch screen center to go back to original screen size. At Full Screen, press the button on top of the screen to show workout information. The information disappears after 3 seconds. Also, you are able to adjust speed and incline from Quick Shift or Slide Bar.



PROGRAMS

2.1.8. BULLETIN BOARD: Information about club news and classes.



2.1.9. INTERNET: Preset website link.



PROGRAMS

2.2. QUICK START OPERATION: Press Quick Start button and treadmill will enter into a manual mode of operation. All energy expenditure values will be calculated using the default weight measurement.

2.3. Training Courses:

2.3.1. Choose Training Courses :

- 2.3.1.1. **Manual:** Manual is a workout that allows you to manually adjust the speed and incline values at any time.
- 2.3.1.2. **Hill:** Hill is a level-based workout that automatically adjusts the resistance value to simulate walking or running up hills.
- 2.3.1.3. **FATBURN:** Fat Burn is a level-based workout that is designed to help users burn fat through various level changes.
- 2.3.1.4. **CARDIO:** Cardio is a level-based workout that is design to help increase cardiovascular.
- 2.3.1.5. **STRENGTH:** Strength is a level-based workout that is designed to help users increase strength through various level changes.
- 2.3.1.6. **INTERVAL:** Interval is a level-based workout that is designed to help users increase endurance
- 2.3.1.7. **CUSTOMIZE:** Users can set up incline level and time for each section.



2.3.2. Choose program and enter desired intensity then press GO to start workout.

2.3.2.1. Enter user weight (user weight is used to calculate the caloric expenditure value-providing an accurate weight helps to ensure an accurate caloric expenditure rating for each user) using the NUMBER KEYPAD and press ENTER.

2.3.2.2. Enter the desired workout length using the NUMBER KEYPAD and press ENTER.

2.3.2.3. Enter the desired intensity level using the QUICK KEY choose EASY, MEDIUM, HARD.



PROGRAMS

2.4. Goal Training Program Setting

2.4.1. Enter user weight (user weight is used to calculate the caloric expenditure value-providing an accurate weight helps to ensure an accurate caloric expenditure rating for each user) using the NUMBER KEYPAD and press ENTER.

2.4.2. Choose desired goal: Time/ Distance/ Calories

2.4.3. Enter the desired workout target using the NUMBER KEYPAD and press ENTER.

2.4.4. Press GO to begin the workout.



2.5. Adjust target setting during workout at SPORT MODE.

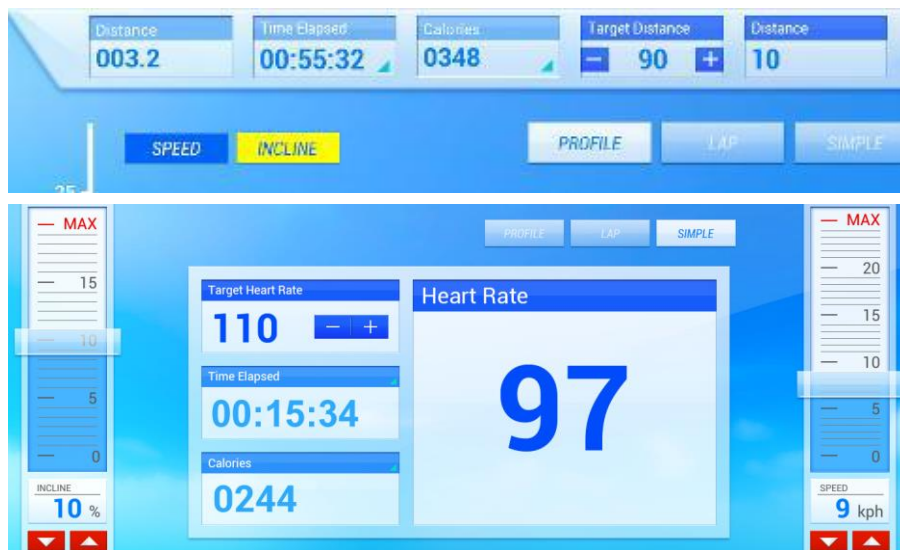

PROGRAMS

2.6. HEART RATE CONTROL WORKOUT OPERATION

2.6.1. Choose TARGET HEART RATE by selecting the target heart rate workout button.

2.6.1.1. **FAT BURN:** Set 65% of your maximum heart rate, program will adjust the intensity to reach the target heart rate.

2.6.1.2. **AEROBIC:** Set 75% of your maximum heart rate, program will adjust the intensity to reach the target heart rate.

2.6.1.3. **PERFORMANCE:** Set 85% of your maximum heart rate, program will adjust the intensity to reach the target heart rate.

2.6.1.4. **Customize:** Setup your target heart rate manually, program will adjust the intensity to reach the target heart rate.



2.6.2. Choose TARGET HEART RATE by selecting the target heart rate workout button and press **GO** to begin the workout.

2.6.2.1. **Weight:** Enter user weight by NUMBER KEYPAD

2.6.2.2. **Age:** Enter user age by NUMBER KEYPAD

2.6.2.3. **Time:** Enter the desired workout length by NUMBER KEYPAD.

2.6.2.4. Press **GET MY HEART**, system will calculate MAX TARGET HEART RATE automatically. Press **EDIT** to adjust TARGET HEART RATE.



2.7. PHYSICAL TEST OPERATION

2.7.1. Choose PHYSICAL TEST by selecting the **PHYSICAL TEST** workout button

2.7.1.1. **GERKIN PROTOCOL:** The Gerkin protocol was developed by Dr. Richard Gerkin of Phoenix (Arizona) Fire Department. It is a sub-maximal graded treadmill evaluation used by many Fire Departments across the United States to assess the physical condition of the firefighters. The test requires constant monitoring of the user's heart rate so the use of a telemetric chest strap is highly encouraged. Operates as follows:

2.7.1.1.1. **WARM UP:** The warm-up is 3 minutes long and runs at 4.8kph (3.0mph) and 0% incline.

2.7.1.1.2. **STAGE 1:** At the 3 minute mark, the treadmill will gradually increase speed to 7.2kph (4.5mph). The actual test begins at 7.2kph (4.5mph).

PROGRAMS

- 2.7.1.1.3. STAGE2: After one minute, the treadmill incline will increase to 2%
- 2.7.1.1.4. STAGE3: After one minute, the treadmill speed increase to 8.0kph (5.0mph)
- 2.7.1.1.5. STAGES 4 THROUGH 11: After every odd minute, the treadmill incline will increase by 2%. After every even minute, the treadmill speed will increase by 0.8kph (0.5mph). Once the user's heart rate exceeds to target heart rate (85% of maximum as determined by the equation $(220 - \text{Age}) * \% = \text{Target heart rate zone}$), the individual continues the evaluation for an additional 15 seconds. During the 15 second period, the evaluation remains at the stage where the target heart rate is exceeded, without any change to speed or incline. If the heart rate does not return to or below the target heart rate, the evaluation ends and the final evaluation stage is recorded. If the heart rate returns to or below the target heart rate, the programs continues at the point where it would have been had the program not stabilized for 15 seconds.
- 2.7.1.1.6. TEST COMPLETION: The test is completed when user heart rate exceeds the target for more than 15 seconds or the user completes all 11 stages, whichever occurs first, the treadmill will enter a cool down cycle for 3 minutes at 4.8kph (3.0mph), 0% incline.
- 2.7.1.2 COOPER TEST: The Cooper test is a physical fitness test for US military. The point of the test is to run as far as possible within 12 minutes.
- 2.7.1.3 USMC PFT: Marine Corps Physical Fitness Test, This is a timed event for 4.8km/3miles run. The goal is for a marine to complete the measured course as quickly as possible.
- 2.7.1.4 ARMY PRT: Army Physical Readiness Training, This is a timed event for 3.2km/2 miles run. The goal is for an army to complete the measured course as quickly as possible.
- 2.7.1.5 NAVY PRT: Navy Physical Training, This is a timed event for 2.4km/1.5miles run. The goal is for a Navy to complete the measured course as quickly as possible.
- 2.7.1.6 USAF PFT: Air Force Physical Fitness Test, This is a timed event for 2.4km/1.5 miles run. The goal is for an Air force to complete the measured course as quickly as possible.
- 2.7.1.7 FEDERAL LAW: This is a timed event for 2.4km/1.5 miles run. The goal is to complete the measured course as quickly as possible.
- 2.7.1.8 VO2 MAX: VO2 max, or maximal oxygen uptake, is one factor that can determine an athlete's capacity to perform sustained exercise and is linked to aerobic endurance.



2.7.2 Choose Physical Test by selecting the physical test workout button and press **GO** to begin the workout.

- 2.7.2.1 Weight: Enter user weight by NUMBER KEYPAD
- 2.7.2.2 Age: Enter user age by NUMBER KEYPAD
- 2.7.2.3 Gender: Select gender by press **MALE** or **FEMALE**.



PROGRAMS

2.8. VITRUAL CONNECT OPERATION

2.8.1. Choose Virtual Connect video by selecting the video:



2.8.2. Set up information then press **GO** to begin the workout.

2.8.2.1. Weight: Enter user weight by NUMBER KEYPAD.

2.8.2.2. Time: Enter desired workout length by NUMBER KEYPAD.

2.8.2.3. INTER ACTIVE set up: INTER ACTIVE ON-elevation change according to video/ INTER ACTIVE OFF-elevation adjust manually.

Note: change video during workout, inter active set up will turn to inter active off.



2.9. MULTIMEDIA OPERATION

2.9.1. TV: Preset favorite TV channel and volume. Same as TV function in Quick Start Mode.

2.9.2. Music: Connect smart phone and set up volume. Same as Music function in Quick Start Mode.

2.9.3. Bulletin Board: Review AD and Classes information. Same as Bulletined Board in Quick Start Mode.

2.9.4. Fit Goal OPERATION

2.9.4.1. Fit Goal setting :

2.9.4.1.1. Please download the free FitGoal APP from Apple Store or Google Play.

2.9.4.1.2. Turn **ON** the Bluetooth of the treadmill

2.9.4.1.3. Connect with your cell phone or tablet. After connecting, the indicate sign will change from **RED** to **GREEN**. Treadmill will not be able to operate from the button of the touch screen.

2.9.4.1.4. Use your cell phone or tablet to operate the FitGoal APP. Setup user's information then press **START** to begin the workout. Please follow the instructions from the APP to operate or press **QUICK START** to begin the workout. FitGoal will record history and excise information during the workout.

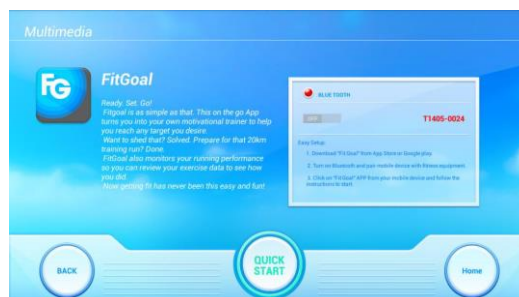

PROGRAMS

- 2.9.5. Internet ICONs: Preset webpage link from treadmill, press the ICON and directly open the webpage. Same function as INTERNET at QUICK START MODE.



OPERATION

1. Headphone jack and USB port.



USB: For Workout Summary
Data Saving and Software
Updating

Headphone Jack
(3.5mm)

2. Cell Phone Music.

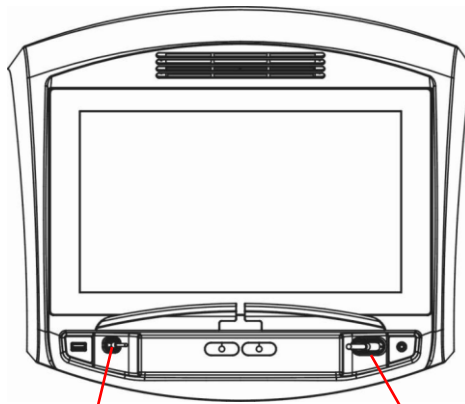

Android Compatible:
Cell Phone support
MTP

iOS Compatible Supported
i-Phone 4S, i-Phone 4,
i-Phone 3GS/ i-Pod touch
Generation 1 - 4

OPERATION

3. Quick Shift:

Speed Quick Shift: Press Quick Shift **UP** to increase speed or **DOWN** to decrease speed.

Incline Quick Shift: Press Quick Shift to incline or down to decline.

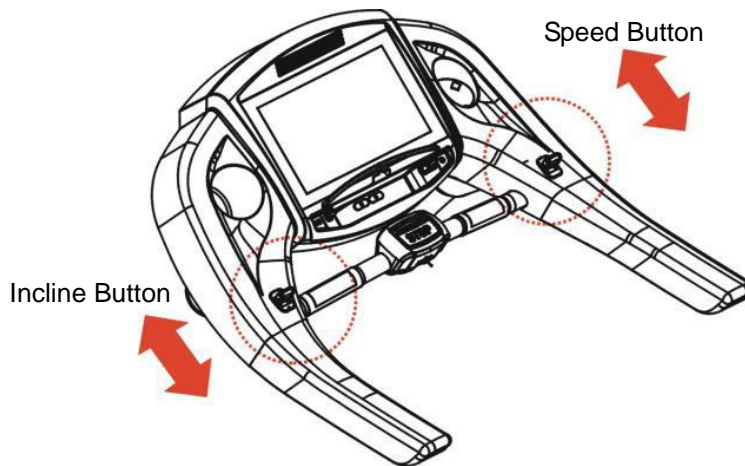

4. FOLLOW THESE INSTRUCTIONS TO LEVEL YOUR TREADMILL:

An uneven floor or improper adjustable pad level can cause the treadmill to wobble during use as well as the incline adjustment to function incorrectly. Please follow the procedure described below to make sure the treadmill adjustable pad is adjusted correctly prior to use. You may need the assistance of another person to perform this adjustment.

First locate the two adjustable pads under the running deck frame. Loosen the screws of adjustable pad cover, and remove the adjustable pad cover. Then simply rotate them in or out to adjust the level of the treadmill. When properly adjusted the treadmill should sit firmly on both adjustable pads and all cushions.

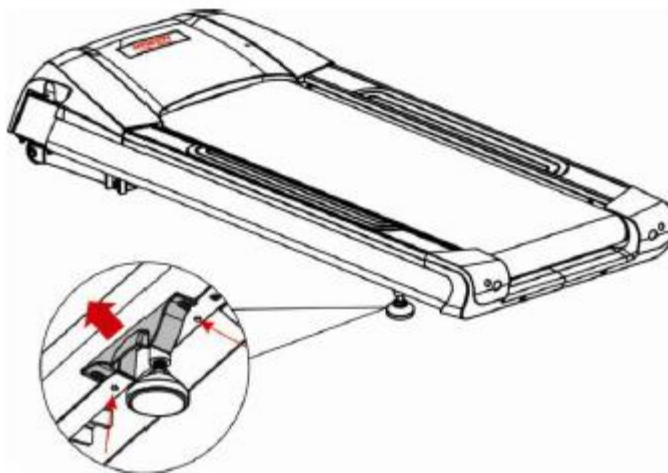

OPERATION

5. Running Belt Travel Area:

The running belt should be centered and adjusted within the area which has been indicated by the arrows on right roller cover and left roller cover. The running belt can be worn and damaged if the running belt travels beyond this scope.

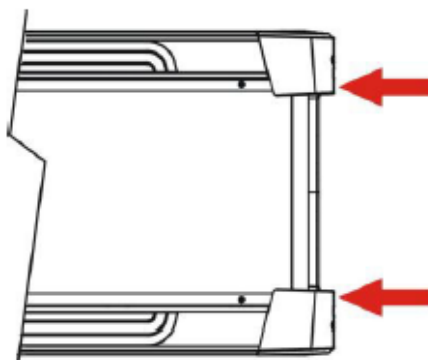

BELT ADJUSTMENT

BELT ADJUSTMENT

You may need to adjust the running belt during the first weeks of use. All running belts are properly set at the factory. It may stretch or be off-center after use. Stretching is normal during the break-in period.

ADJUSTING THE BELT TENSION

If the running belt feels as though it is "slipping" or hesitating when you plant your foot during a run, the tension on the running belt may have to be increased.

TO INCREASE THE RUNNING BELT TENSION

- A) Place 6mm wrench on the left belt tension bolt. Turn the wrench clockwise 1/4 turn to draw the rear roller and increase the belt tension.
- B) Repeat STEP "A" for the right belt tension bolt. You must be sure to run both bolts the same number of turns, so the rear roller will stay square relative to the frame.
- C) Repeat STEP "A" and STEP "B" until the slipping is eliminated.
- D) Be careful not to tighten the running belt tension too much as you can create excessively pressure on the front and rear roller bearings. An excessively tightened running belt may damage the roller bearings that would result in bearing noise from the front and rear rollers.

TO DECREASE THE TENSION ON THE RUNNING BELT, TURN BOTH BOLTS COUNTERCLOCKWISE THE SAME NUMBER OF TURNS.

CENTERING THE RUNNING BELT

When you run, you may push off harder with one foot than with another. The severity of the deflection depends on the amount of force that one foot exerts in the relation to the other. This deflection can cause the belt to move off-center. This deflection is normal and the running belt will be balanced or no body is on the running belt. If the running belt remains consistently off-center, you will need to center the running belt manually.

- A) Start the treadmill without anyone on the running belt. Press **SPEED UP** button until speed reached 6 kph.
- B) Observe whether the running belt is toward the right or left side of the deck.
 - a. If toward the left side of the deck:
Using wrench, turn the left adjustment bolt clockwise ¼ turn and the right adjustment bolt counterclockwise ¼ turn.
 - b. If toward the right side of the deck:
Using wrench, turn the right adjustment bolt clockwise ¼ turn and the left adjustment bolt counterclockwise ¼ turn.
 - c. If the belt is still not centered, repeats the above steps until the running belt is on center.
- C) After the belt is centered, increase the speed to 16kph and verify that it is running smoothly. Repeat the above steps if it is necessary. If the above procedure is unsuccessful in resolving the off-center, you may need to increase the belt tension.

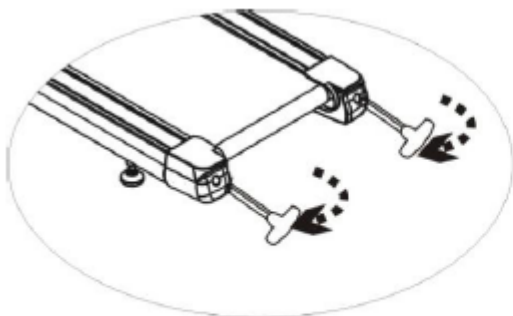

Turn clockwise to increase the running belt tension

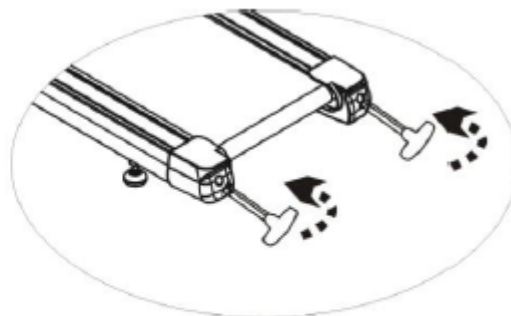

Turn counter-clockwise to decrease the running belt tension

CARE & MAINTENANCE

CARE & MAINTENANCE

Always remove the key and unplug the power cord before cleaning, lubricating, or performing any maintenance.

Other parts maintenance:

Number	Checking Item	Daily	Week	Month	Season	6 Months
1	Console Screws					Checking
2	Frame	Wipe				Checking
3	Running Surface		Clean(dust)			Checking
4	Power Code			Checking		
5	Overlay	Wipe		Checking		
6	Handle bar	Wipe				Checking
7	Handle bar screws				Checking	
8	Front Roller & Groove				Wipe	Checking
9	Rear Roller					Checking
10	Safety Key	Wipe				
11	Drive Belt				Wipe	Checking
12	Running belt tension					Checking
13	Motor Control					Clean(dust)
14	Motor Pulley & Groove					Checking

HOW DO I CLEAN MY MACHINE?

Clean with soap and water cleaners only. Never use solvents on plastic parts. Cleanliness of your treadmill and its operating environment will keep maintenance problems and service calls to a minimum. For this reason, Customer Tech Support recommends that the following preventive maintenance schedule be followed.

DAILY

- Unplug the treadmill. Clean entire machine using water and a mild soap or other Green Series Fitness approved solution (cleaning agents should be alcohol and ammonia free).

MONTHLY or QUARTERLY (depending on usage or dirty environments)

- Unplug the treadmill and remove the motor cover. Check for debris and clean with a dry cloth and small vacuum nozzle. **DO NOT** vacuum directly on electronics board. Either blow with mouth or compressed air to clean electronic components.

WARNING: Do not plug the treadmill in until the motor cover has been reinstalled.

RECOMMENDED CLEANING TIPS

Preventative maintenance and daily cleaning will prolong the life and look of your equipment.

- A Use a soft, clean cotton cloth. **DO NOT** use paper towels to clean surfaces on the treadmill. Paper towels are abrasive and can damage surfaces.
- B Use a mild soap and damp cloth. **DO NOT** use ammonia based cleaner or alcohol. This will cause discoloring of the aluminum and plastics it comes into contact with.
- C Do not pour water or cleaning solutions on any surface. This could cause electrocution.

CARE & MAINTENANCE

- D Wipe the console, heart rate grip, handles and side rails after each use.
- E Brush away any wax deposits from the deck and belt area. This is a common occurrence until the wax is worked into the belt material.
- F Be sure to remove any obstructions from the path of the elevation wheels including power cords.
- G For cleaning console displays, use distilled water in an atomizer spray bottle. Spray distilled water onto soft, clean, dry cloth and wipe display until clean and dry. For very dirty displays, adding vinegar is recommended.

CAUTION: Be sure to have proper assistance to install and move the unit in order to avoid injury or damage to the treadmill.

CHECK FOR DAMAGED PARTS

DO NOT use any equipment that is damaged or has worn or broken parts. Use only replacement parts supplied by Green Series Fitness.

MAINTAIN LABELS AND NAMEPLATES Do not remove labels for any reason. They contain important information. If unreadable or missing, contact Green Series Fitness for a replacement or an authorized service provider.

MAINTAIN ALL EQUIPMENT Preventative maintenance is the key to smooth operating equipment, as well as keeping the user's liability to a minimum. Maintain a clean area around the equipment, free from dust and dirt. Equipment needs to be inspected at regular intervals. Defective components must be replaced immediately. Improperly working equipment must be kept out of use until it is repaired. Ensure that any person(s) making adjustments or performing maintenance or repair of any kind is qualified to do so.

DECK AND BELT REPLACEMENT

One of the most common wear and tear items on a treadmill is the deck and belt combination. If these two items are not properly maintained they can cause damage to other components. This product has been provided with the most advanced maintenance free lubricating system on the market.

WARNING: Do not run the treadmill while cleaning the belt and deck. This can cause serious injury and can damage the machine. Maintain the belt and deck by wiping the sides of the belt and deck with a clean cloth. The user can also wipe under the belt 2 inches (~51mm) on both sides removing any dust or debris. The deck can be flipped and reinstalled or replaced by an authorized service technician. Please contact Green Series Fitness for more information.

STORAGE

Store your treadmill in a clean and dry environment. Ensure the master power switch is **OFF** and is unplugged from the electrical wall outlet.

MOVING

This treadmill has been designed and equipped with wheels for easy mobility. Before moving, ensure the master power switch is in the **OFF** position and the power cord is unplugged from the electrical outlet.



TROUBLE SHOOTING

SYMPTOM	CAUSE	SOLUTION
Console display does not illuminate	A).No power to treadmill. B).Console wire is not connected or incompletely. C).Overload, protecting is started. D).Console power source damaged	A). Check the on-off switch is ON , switch indicator shall be on. if not, check AC power source. B). Check console wiring connector points are connected correctly, including outward and connector point insert PINs. C). Check fuse(near on-off switch) is working or not, if working, push it back, and restart again, if not working perform maintenance of the running belt and deck. D). Turn OFF power then open the motor cover, turn ON the power and check the console power pilot lamp(LED2) on the interface PCB, it shall be light completely, if not, replace it.
Display not completely showing	A). Console damaged. B). Console source power unstable.	A). Replace the console PCB. B). Turn OFF the ON/OFF switch, then open the motor cover. Turn ON the power again to see if the Console Power pilot lamp (LED1) on the interface PCB is completely lit. The interface needs to be changed if the interface power doesn't light up.

If the supply cord is damaged, it must be replaced by the manufacturer or its service provider or a similarly qualified person in order to avoid a hazard.

Walking Belt Slipping, Jerking, Slowing

When a walking belt slips, jerks or slows when walking on it generally indicates a tension problem.

Walking Belt:

The walking belt tension is different depending on the thickness of the walking belt. The thicker the belt, the looser it may be. Walking belt tension should be as loose as possible without slipping for the longest life span of the walking belt. Refer to the owner's manual has instructions on how to adjust the walking belt.

Worn Walking Belt:

Walking belts have a grip system on the underside just like the top. If you have already adjusted the tension of the walking belt and it is still slipping, feel the underside of the walking belt. If the underside of the walking belt feels smooth, you may need to replace the walking belt.

Lubricant:

Each new treadmill deck and walking belt comes pre-lubricated. To check for lubricant, run your fingers on the underside of the walking belt. If your fingers come out with a shiny gloss (not wet) there is plenty of lubricant. If it is rough and dry, a single application of **approved lubricant** may be applied to the walking belt. If the treadmill has been in storage or not used for an extended period of time, the lubricant may dry out and need a new application. Multiple applications of lubricant are **NOT** necessary and may result in damage to the walking belt and or deck.

Type of Lubricant:

Use only approved lubricant on the walking belt and deck. Green Series Fitness requires the use of **Silicon** lubricant. Using wax or spray type lubricant, or others, will result in a buildup of a sticky substance on the walking belt and deck. This buildup will result in the replacement of the walking belt and potentially the deck. **The usage of non-approved lubricants will result in the walking belt and deck warranty to be void.** It will be the responsibility of the customer to pay the costs associated for the parts and labor to replace such components.

Treadmill Breaker or Main Service Breaker Tripping

Worn Deck:

One of the indicators of a worn treadmill deck is the tripping of the treadmill breaker and/or the main service breakers. A worn treadmill deck causes additional resistance between the walking belt and the surface of the deck. This added resistance will cause an increase of the power required to operate the treadmill and potentially cause the power inverter and the walking belt to overheat thus causing the breakers to trip. With your hand, reach in between the walking belt and the deck. Feel the surface of the deck. If the deck is smooth and without "ridging", then the cause is likely elsewhere. If the you or technician feels that the deck is rough to the touch or has ridges running the length of the deck, then the deck is likely the cause of the tripping breakers and the deck needs replacement.

TROUBLE SHOOTING

Power Inverter or Lower Board:

If it has been determined that the walking belt and deck are not the cause of the breakers tripping, then the next step is to verify the correct operation of the Power Inverter or lower board. If it is possible, exchange the power inverter with a power inverter of a treadmill which is not experiencing this problem. If the problem follows the exchanged power inverter, then replace the power inverter. If the problem does not follow the power inverter, then the problem is elsewhere and additional troubleshooting is required to locate the problem.

If you do not have another treadmill to exchange components with, feel the surface of the power inverter to determine if it is hot to the touch. If it is hot to the touch, replace the power inverter.

PART LIST

ITEM	Part No.	DESCRIPTION	Q'TY	ITEM	Part No.	DESCRIPTION	Q'TY
1-1	H020801-002	Screw M5x12 L. roller cover	6	2-1	F500199-001	Console frame	1
1-2	H041013-000	Drive belt	1	2-2	F300621-102	Upper console cover /K90	1
1-3	F205002-001	Right side rein	1	2-3	H020803-000	Screw M4x10L	8
1-4	F205001-001	Left side rein	1	2-4	H020202-004	Bolt M4x12L, Upper console cover	2
1-5	H020830-000	Bolt M8x40L	2	2-5	F300622-102	Right Console Cover Rib /K90	1
1-6	F500270-000	Running deck frame	1	2-6	F300623-102	Left Console Cover Rib /K90	1
1-7	F880333-000	Incline rack set	1	2-7	H020173-000	Bolt M4x12L	19
1-7-1	F500193-002	Incline rack	1	2-8	F300609-101	Bottle Holder /K90	1
1-7-2	F330030-000	Rubber piece	2	2-9	F330075-000	Rubber Pad, Bottle Holder	3
1-7-3	H020626-003	Bolt M8x20L, Rubber piece	2	2-10	H020252-000	Screw M4x10L, Bottle Holder	6
1-7-4	F290051-001	Wheel axle center	2	2-11	F300310-103	Lower console cover /K90	1
1-7-5	F300346-000	Mobile wheel	2	2-12	H020206-000	Screw M5x12L, Lower console cover	7
1-7-6	H021109-039	Washer, mobile wheel	4	2-13	H020806-000	Bolt M4x10L, Lower console cover	2
1-7-7	H020302-017	Bolt M10x70L, mobile wheel	2	2-14	F300624-102	Console set /K90	1
1-7-8	H022303-000	Nut M10	2	2-15	F300625-102	Right Reading Rack /K90	1
1-7-9	H021205-000	S Washer \varnothing 10.7x \varnothing 16.9x2.2t mm	2	2-16	F300626-102	Left Reading Rack/K90	1
1-8	F060000-000	Bushing	2	2-17	F900485-000	Fan	1
1-9	H020674-001	Bolt 1/2"x3-1/4", lift arm	2	2-18	F373430-000	Main PCB	1
1-10	H022314-001	Bolt 1/2"x8t, lift arm	2	2-19	F373399-000	Panel	1
1-11	H020302-017	Bolt M10-70L, lift arm	1	2-20	F373400-000	Touch	1
1-12	H022303-000	Nut M10, lift arm	6	2-21	F373401-000	15.6" Touch	1
1-13	F991009-004	Incline motor	1	2-22	F373404-000	TV Tuner	1
1-14	F300037-000	Incline motor Bushing	2	2-23	F373403-000	WiFi Antenna	1
1-15	H020302-014	Bolt M10x45L, Incline motor	1	2-24	F270763-000	15.6" Panel Box	1
1-16	F270246-002	Wire set plate	1	2-25	F373412-002	USB Drive	1
1-17	F091001-001	Fuse	1	2-26	H020224-000	Screw M3x8mm, Panel Box	11
1-18	H020118-001	Screw M3x8L, wire set plate	2	2-27	F373409-000	USB Port	1
1-19	F376002-000	Electric socket	1	2-28	F080231-000	USB board cable	1
1-20	F090012-000	On-off switch	1	2-29	F373410-000	Audio In Jack	1
1-21	F994003-001	Motor	1	2-30	F080232-000	Aux board cable	1
1-22	F379001-000	Clip, motor	2	2-31	H020201-002	Screw M3x6L, USB Port / Csafe PCB	8
1-23	H020302-016	Bolt M10x30L, motor	4	2-32	F270537-000	Set Plate	1
1-24	F330033-000	Rubber plate, motor	1	2-33	F913015-000	Cable lock	1
1-25	H020615-007	Bolt M10x25L, motor	4	2-34	F330072-000	Cable storage	1
1-26	H021205-000	S Washer, motor	8	2-35	F330073-000	Wire connector	2
1-27	H021109-022	M10 washer, motor	12	2-36	F900839-001	I-POD Cable	1
1-28	F270275-000	Adjustment plate, motor	1	2-37	F080233-000	Android Cable	1
1-29	F300043-002	Transistor washer	4	2-38	F330080-000	Cable storage	1
1-30	F083104-004	Power cord	1	2-39	H021132-000	M5 washer, USB Cable	1
1-31	F372046-001	Inverter	1	2-40	F880388-000	Hand Pulse Assembled Set /K90	1
1-32	H020803-000	Screw M4x10L	10	2-40-1	F500437-000	Hand pulse Set	1
1-33	F570060-001	Running belt	1	2-40-2	F300631-103	Emergency Stop Base /K90	1
1-34	H020802-002	Bolt M8x30L, running deck	2	2-40-3	F301012-000	Emergency Stop Cover	1
1-35	F580027-000	Running deck	1	2-40-4	F373406-001	Emergency Stop Key	1
1-36	F300347-000	Packing	8	2-40-5	H020201-002	Screw M3x6L, Emergency Stop Cover	6
1-37	H020600-035	Bolt M6x15L, packing	8	2-40-6	H021110-001	M4 washer, Emergency Stop Cover	2
1-38	H021101-047	Washer, packing	12	2-40-7	H020252-000	Screw M4x10L, Emergency Stop Cover	6
1-39	F330059-000	Rubber cushion 37L	6	2-40-8	H029114-101	Spring	2
1-40	F300303-000	Adjustable pad	2	2-40-9	F010504-001	Safety Key Thread	1
1-41	F500228-001	End cap set plate, left	1	2-40-10	F300632-102	Emergency Stop Lower Cover /K90	1
1-42	F500229-001	End cap set plate, right	1	2-40-11	H020803-000	Screw M4x10L, Emergency Stop Lower Cover	4
1-43	F298012-001	Front roller	1	2-40-12	F080222-000	Emergency Stop Cable/1000mm	1
1-44	H020626-005	Bolt M8x35L, front roller	2	2-40-13	F300341-000	Hand pulse upper cover	2
1-45	H021209-000	S Washer, front roller	4	2-40-14	F300281-000	Hand pulse lower cover	2
1-46	F299013-001	Rear roller	1	2-40-15	H020109-014	Screw M3x20L, Hand pulse lower cover	4
1-47	H020608-001	Bolt M8x70L, rear roller	2	2-40-16	F270271-000	Hand pulse plate	4
1-48	F300314-102	Left roller cover /K90	1	2-40-17	F914015-001	Form	2
1-49	F300315-102	Right roller cover /K90	1	2-40-18	F914030-000	Form	2
1-50	F330031-001	Rubber cushion 15L	2	2-40-19	F080221-000	Hand Pulse Transfer, 700mm	2
1-51	H020638-001	Bolt M8x20L	6	2-40-20	F303033-001	Electronic spring	1
1-52	F270674-000	Tooth plate	2	2-40-21	H021107-001	Washer \varnothing 5.2x \varnothing 10x0.8t mm	4
1-53	F080162-002	TV Cable	1	2-41	F373405-000	Heart Rate PCB	1
1-54	F080225-000	Lower Console Wire, Power(2P)	1	2-42	F080221-001	Transfer Cable, 100mm	1
1-55	F080226-000	Lower Console Wire, Wi-F(4P)	1	2-43	F080221-002	Transfer Cable, 410mm	1
1-56	F372050-000	Transformer	1	2-44	F080229-000	Quick Shift Cable	2
1-57	H022302-000	Nut M8x6.8t	6	2-45	F373387-000	BT board	1
1-58	H021109-039	Washer \varnothing 10.1x \varnothing 25.2x1.5t mm	2	2-46	F080198-001	BT cable	1
1-59	H021605-001	S Washer, wire set plate	2	2-47	F916405-002	Stickers(Left) /K90	1
1-60	H021130-005	Washer \varnothing 13.1x \varnothing 26.1x2t mm	4	2-48	F916405-003	Stickers(Right) /K90	1
1-61	H020302-030	Bolt M10x45mm	1	2-49	F080162-003	TV Cable wire	1
1-62	H022102-004	Nut M10	2	2-50	F080227-000	Upper console wire, Power (2P)	1
1-63	H022800-001	Tooth plate	2	2-51	F080228-000	Upper console wire, Wi-Fi (4P)	1
1-64	F916273-151	Right side rail sticker	1	2-52	F916406-010	Sticker /K90	1
1-65	F916273-152	Left side rail sticker	1	2-53	H020603-004	Bolt M8x15L	2
1-66	F377007-001	Wave filter	1	2-54	F419002-000	Connector-1	1
1-67	H020803-000	Bolt / M4x0.7-10Lmm	2	2-55	F419004-000	Connector-2	1
1-68	F916215-001	Non-slip sticker	2	2-56	F373424-000	Csafe PCB	1
1-69	H020603-004	M10 washer, Rubber cushion 37L	6	2-57	F083133-000	Csafe power	1
1-70	H021101-002	M6 washer, Roller cover	4	2-58	F300646-100	Csafe cover	1
				2-59	F346007-000	Cooper Tube	1
				2-60	F916346-013	Logo	1

PART LIST

ITEM	Part No.	DESCRIPTION	Q'TY	ITEM	Part No.	DESCRIPTION	Q'TY
3-1	F900393-000	Right handlebar	1			QUICK SHIFT	
3-2	F900392-000	Left handlebar	1	4-1	F880335-000	QUICK SHIFT	1
3-3	H020602-004	Bolt M8X25L	22	4-1-1	F240006-000	Quick shift cover	2
3-4	H021120-004	M8 washer	22	4-1-2	H020100-000	Screw M3X6L	12
3-5	F300306-102	Right console mast cover	1	4-1-3	F240008-001	Quick shift base cover (right)	1
3-6	F300305-102	Left console mast cover	1	4-1-4	H021111-000	M3 washer	4
3-7	H020822-002	Screw M5X15L	6	4-1-5	H020100-001	Screw M3X6L	4
3-8	F330039-000	Packing	2	4-1-6	F240007-000	Quick shift pushing base	2
3-9	F900394-007	Console mast set	1 set	4-1-7	H020801-002	Screw M5X12L	8
3-10	F300304-102	Upper motor cover	1	4-1-8	F373256-000	Quick shift board	2
3-11	F300418-000	Right adjustable pad cover	1	4-1-9	F290080-000	Pin	2
3-12	F300417-000	Left adjustable pad cover	1	4-1-10	F270428-000	Quick button fixing bracket	2
3-13	H020801-002	Bolt M5X12L	6	4-1-11	H021605-001	S washer M5	8
3-14	H021209-000	M8 S washer	22	4-1-12	F270658-000	Quick button fixing bracket (left)	1
3-15	F300282-002	End cap	4	4-1-13	F270657-000	Quick button fixing bracket (right)	1
3-16	F270690-000	Connector plate	1	4-1-14	F240005-001	Quick shift base cover (left)	1
3-17	H020803-005	Screw M4X12L	2	4-1-15	H028300-000	Hex Screw	8
3-18	F916212-032	logo	1	4-1-16	F330054-000	Pad / ø5.9-1.9t	4
3-19	H022800-001	Tooth plate	4	4-1-17	H022311-000	Nut / M3x0.5x4t	2
3-20	F419002-000	Connector	1	4-1-18	H029108-000	Spring	4
3-21	F916438-000	Green Series Logo	2	4-1-19	F916295-002	Pad	4
3-22	F270222-000	Power cord locker	1	4-1-20	F916295-003	Pad 34x20x5t	2
3-23	H020201-003	Bolt M3X12L	1				
3-24	F419008-000	Connector	1				

EXPLODED DRAWING

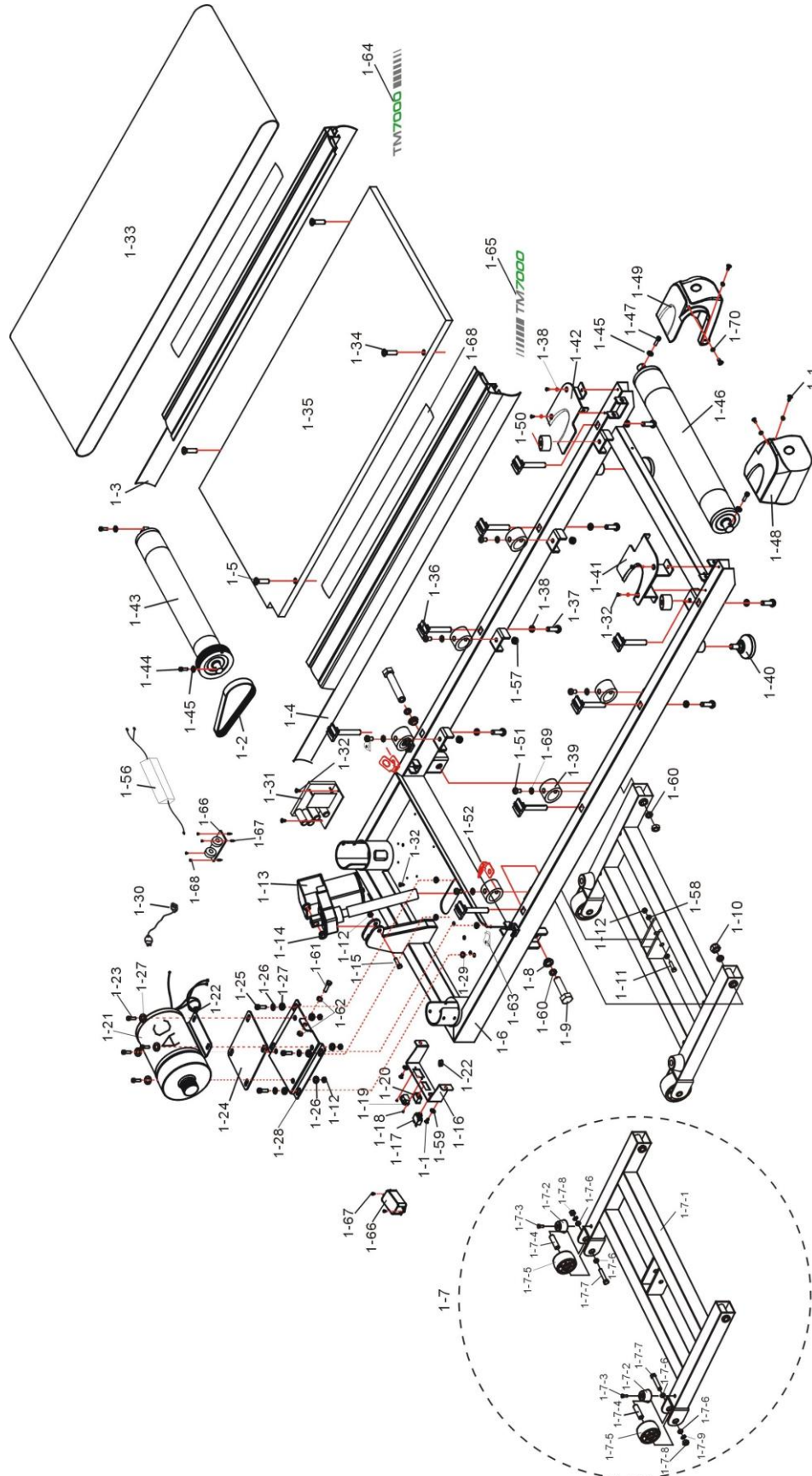

EXPLODED DRAWING (CONSOLE MAST SET)

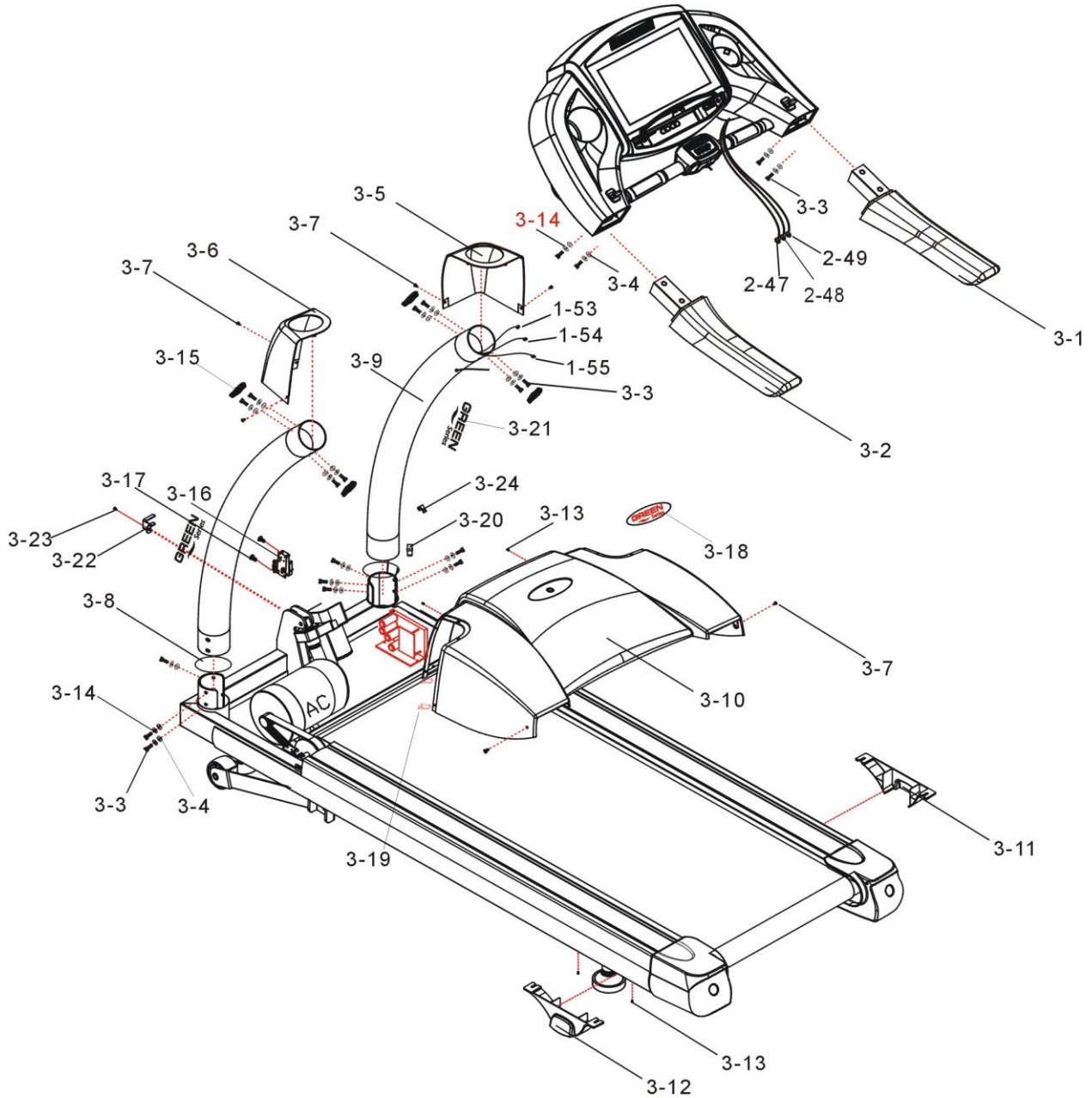



Limited Warranty

6000 SERIES LIGHT COMMERCIAL WARRANTY

The Green Series™ 6000 light commercial warranty is intended for non-dues-paying facilities where equipment use is generally up to eight (8) hours per day.

7000 SERIES FULL COMMERCIAL WARRANTY

The Green Series™ 7000 full commercial warranty is intended for facilities where equipment use is regularly in excess of eight (8) hours per day. All dues-paying facilities fall into the category of a full commercial warranty as well as many non-dues-paying facilities.

Please note that any warranty services or questions must be accompanied by the model number and serial number from the transaction through which the warranted product was purchased. ***The serial number serves as your warranty number and must be retained.*** GREEN SERIES™ cannot provide warranty service without this number.

GREEN SERIES™ Cardio Machines warrant this product and its parts against defects in materials or workmanship for ***ten (10) years frame, five (5) years motor, three (3) years parts, two (2) years wearables and one (1) year labor*** from the initial install date. During this period, GREEN SERIES™ will repair or replace defective parts or equipment with new or reconditioned parts at GREEN SERIES™ option, without charge to customer. This limited warranty extends only to the original purchaser and is non-transferable. *(Excluding Indoor Cycling Bikes)*

GREEN SERIES™ Indoor Cycling Bikes warrant this product and its parts against defects in materials or workmanship for ***five (5) years frame, two (2) years parts, one (1) year wearable and no labor*** from the initial install date. During this period, GREEN SERIES™ will repair or replace defective parts or equipment with new or reconditioned parts at GREEN SERIES™ option, without charge to customer. This limited warranty extends only to the original purchaser and is non-transferable

Shipping fees incurred from returns for under-warranty service in the warranty time-line will be paid by GREEN SERIES™. All shipping fees both to and from GREEN SERIES™ following this warranty time-line period must be paid by the customer. All returns, both during and following the warranty time-line period, must be affected via the Procedures for Obtaining Warranty Service described below.

All original parts (parts installed by GREEN SERIES™ at the original system build) replaced by GREEN SERIES™, its authorized service center or authorized service technician, become the property of GREEN SERIES™. Any after-market additions or modifications void all warranties. The original purchaser is responsible for the payment, at current rates, for any service or repair outside the scope of this limited warranty.

GREEN SERIES™ makes no other warranty, expressed or implied, including but not limited to implied warranties of merchantability, fitness for a particular purpose, or conformity to any representation or description, with respect to this warranty other than as set forth below. GREEN SERIES™ makes no warranty or representation, either expressed or implied, with respect to any other manufacturer's product or documentation, its quality, performance, merchantability, fitness for a particular purpose, or conformity to any representation or description.

Except as provided below, GREEN SERIES™ is not liable for any loss, cost, expense, inconvenience or damage that may result from use or inability to use the equipment. Under no circumstances shall GREEN SERIES™ be liable for any loss, cost, expense, inconvenience or damage exceeding the purchase price of the equipment.

The warranty and remedies set forth below are exclusive and in lieu of all others, oral or written, expressed or implied. No reseller, agent or employee is authorized to make any modification, extension or addition to this warranty.

Warranty Conditions and Restrictions

The above Limited Warranty is subject to the following conditions:

1. This warranty extends only to products distributed and/or sold by **GREEN SERIES™**. It is effective only if the products are purchased and operated in the USA, (Within the USA including US 48 States, Alaska and Hawaii), Puerto Rico, Canada and Mexico. All countries outside the USA for warranty service do not include labor rates.
2. This warranty covers only normal use of the equipment. **GREEN SERIES™** shall not be liable under this warranty if any damage or defect results from (i) misuse, abuse, neglect, improper shipping or installation; (ii) disasters such as fire, flood, lightning or improper electric current; or (iii) service or alteration by anyone other than an authorized **GREEN SERIES™** representative; (iv) damages incurred through irresponsible use, including those resulting from equipment placed into humid environments, unfinished structures, structures under construction or remodel or placed in an outdoors setting, or other non-recommended practices.
3. **GREEN SERIES™** shall not be held liable or responsible for any damages to the units caused during the install of any product.
4. **GREEN SERIES™** shall not be held liable or responsible for any structural or cosmetic damages to facilities caused by the placement or operation of any equipment sold and installed by a **GREEN SERIES™** authorized service technician or installer.
5. Changes in the cosmetic appearance of components and parts within the unit that do not affect its performance will not be covered by any part of this warranty.
6. Damage due to normal wear and tear as defined by items subject to normal use and/or exposure, consumables, and cosmetic items, including, but not limited to the following: grips, seats, paint scratches, and labels.
7. Travel costs associated with service more than 100 miles or two hours outside the service area of **GREEN SERIES™** service technicians shall be the responsibility of the customer.
8. Any and all shipping damages, visible or hidden, shall be the responsibility of the shipper. Note: Damage caused by common carrier is, by federal law, the carrier's responsibility and must be claimed with the carrier at the time of delivery. The recipient who signed for the equipment is responsible for the filling of the damage claim and notification to **GREEN SERIES™**.
9. The end user of the equipment shall ensure that the facility has proper height, width and length clearances, including ADA requirements, for the product(s) being placed into operation. **GREEN SERIES™** will not be held liable or responsible for the fitment of equipment sold to the customer.
10. Customer must retain bill of sale or other proof of purchase and register equipment within thirty (30) days of installation to receive warranty service. Registration of the equipment ensures **GREEN SERIES™** the ability to provide prompt and complete service.
11. No warranty extension will be granted for any replacement part(s) furnished to the purchaser in fulfillment of this warranty.
12. **GREEN SERIES™** and its Authorized Service Center, dealers or authorized technicians accept no responsibility for any parts of any products returned for repair to **GREEN SERIES™**.
13. **GREEN SERIES™** makes no warranty either expressed or implied regarding third-party (**non-GREEN SERIES™**) installed parts, accessories or modifications.
14. All **GREEN SERIES™** equipment shall be properly cleaned and cared for in accordance to the procedures outlined the in the owner's manual.

Return of Non-Defective Products

A non-defective product may be returned to **GREEN SERIES™** within thirty (30) days of the invoice or installation date for a refund of the original purchase price, not including shipping fees, under the following conditions/fees:

1. **GREEN SERIES™** will refund the cost of equipment only. Customer is responsible for shipping and handling fees incurred to and from the product(s) return.
2. No refund will be granted for equipment which has been opened, used, or tampered with in any way which jeopardizes **GREEN SERIES™** ability to remarket or resell the product. **GREEN SERIES™** maintains full discretion in decisions regarding product returns.
3. Any non-defective returns are subject to a twenty-five percent (25%) restocking fee. This fee will be deducted from the equipment purchase price refund less any shipping or handling charges.

To return a defective product, please contact the selling dealer or Green Series Customer Service Department for a Return Merchandise Authorization (RMA) number and follow the Return of Products Instructions below. The RMA is valid for thirty (30) days from date of issuance. **Returns will not be accepted without an RMA.** Manufacturer restrictions do apply. Any item missing the UPC on the original packaging may not be returned.

Procedures for Obtaining Warranty Service

RMA (Return Merchandise Authorization) Policy:

The customer must obtain an RMA number and provide proof of purchase. RMA and services are rendered by **GREEN SERIES™** only. Any shipping costs after the for-mentioned warranty lengths (starting from the original date of install) on any item returned for repair or replacement is the customers' responsibility. All returned parts and equipment must have an RMA number written clearly on the outside of the package along with a letter detailing the problems and a copy of the original proof of purchase. No COD packages will be accepted. No package will be accepted without a RMA number written on the outside of the package. RMA numbers are only valid for thirty (30) days from the date of issue.

Should you have any problems with your equipment, please follow these procedures to obtain the service:

1. If the equipment must be repaired, contact our Customer Care Department and a **Service Order Number** will be issued by Customer Care for dispatch of an authorized technician.
2. Upon receiving the technician service report, **GREEN SERIES™** will repair or replace your defective parts and will ship replacement parts to the location specified (dependent on parts availability) via UPS.
3. **GREEN SERIES™** will pay for shipping to and from the customer only within the time allocated under the warranty time-line following the original product installation date. Following this period all shipping fees for post warranty repairs are the sole responsibility of the customer. The customer also assumes full liability for losses or damages resulting from shipping as well as all responsibility to pursue remuneration for such issues with their selected carrier.

After Warranty – Post Warranty Repair

For post warranty repair, the procedure is the same as outlined above for service and shipping. However, customer is responsible for shipping charges both ways, labor, trip charges and the current price of part(s) needed to repair the product(s).

WARRANTY EXCLUSIONS

GREEN SERIES™ does not offer technical support for any product or parts installed by other manufacturers. Technical support should be pursued through channels offered by the equipment's individual technician support. **GREEN SERIES™** accepts no liability for problems caused by after-market hardware modifications or additions. **GREEN SERIES™** is not responsible for giving any technical support concerning the installation or integration of any component the customer did not pay **GREEN SERIES™** to install. **GREEN SERIES™** is not responsible for loss of time, even with hardware failure. **GREEN SERIES™** is not responsible for any loss of work ("down time") caused by a product requiring service. This warranty is null and void if the defect or malfunction was due to damage resulting from operation not within manufacturer specifications. It will also be null and void if there are indications of misuse and/or abuse. **GREEN SERIES™** has the option of voiding the warranty if anyone other than a **GREEN SERIES™** authorized technician attempts to service the product. **GREEN SERIES™** will not warrant any problems arising from an act of God (lighting, flooding, tornado, etc.), electrical spikes or surges, or problems arising out of hardware or additional devices added to complement any system/component bought at **GREEN SERIES™**. Under no circumstances will **GREEN SERIES™** be responsible for any refund or remuneration exceeding the original purchase price of the product less any shipping fees. **GREEN SERIES™** will not be held responsible for typographical errors on sales receipts, repair tickets, or on our websites. **GREEN SERIES™** makes every effort to ensure all information on our websites, owner's manuals, marketing and other published materials is accurate.

- **By using this product, I indicate that I understand and agree to the terms of this warranty.**

