

# Owner's Manual

# GREEN Series



## CIR-TM7000-G1

### Full Commercial Treadmill



Full Commercial



Light Commercial



Install Date: \_\_\_\_\_

Serial Number: \_\_\_\_\_

# TABLE OF CONTENTS

<b>SAFETY PRECAUTIONS</b> .....	<b>2-8</b>
Important voltage information, grounding instructions, how often you exercise, how hard you exercise, how long you exercise, beginner treadmill program, target heart rate zone.	
<b>TECHNICAL SPECIFICATIONS</b> .....	<b>9</b>
<b>UNPACKING &amp; ASSEMBLY</b> .....	<b>10-17</b>
Parts, hardware kit and assembly drawing	
<b>WARM UP &amp; COOL DOWN</b> .....	<b>18</b>
<b>CONTROL PANEL</b> .....	<b>19-20</b>
<b>PROGRAMS</b> .....	<b>21-25</b>
<b>OPERATION</b> .....	<b>26</b>
<b>BELT ADJUSTMENT</b> .....	<b>27</b>
<b>CARE &amp; MAINTENANCE</b> .....	<b>28-30</b>
<b>TROUBLE SHOOTING</b> .....	<b>31-32</b>
<b>ENGINEERING MODES</b> .....	<b>33-34</b>
<b>PARTS LIST</b> .....	<b>35-36</b>
<b>EXPLODED DRAWINGS</b> .....	<b>37-39</b>
<b>WARRANTY</b> .....	<b>40-42</b>

# SAFETY PRECAUTIONS

## Location of the Treadmill

Before assembling the unit, verify the chosen site meets the following criteria:

- Area is well lit and well ventilated.
- Surface is structurally sound and properly leveled.
- Free area for access to the unit and emergency dismount. Minimum clearance is 24 inches (0.6 meters) on the sides of the unit and 78.7 inches (2.0 meters) behind the unit.
- Adjacent units may share the free area.
- Place in a location away from direct sunlight. The intense UV light can cause discoloration on the plastics.
- Locate your treadmill in an area with cool temperatures and low humidity.
- Do not install, use or store the treadmill in an area of high humidity, such as in the vicinity of a steam room, sauna, indoor pool, garage, covered patio, near water or outdoors. Exposure to extensive water vapor, chlorine and/or bromine could adversely affect the electronics as well as other parts of the unit.

The below minimum spacing recommendations are based on a combination of the ASTM (U.S.) voluntary standards and EN (European) regulations as of October 1, 2012, for access, passage around, and emergency dismount:

ASTM standards are voluntary and may not reflect current industry standards. The actual area for access, passage around, and emergency dismount is the responsibility of the facility. The facility should consider the total space requirements for training on each unit, voluntary and industry standards, and any local, state, and federal regulations. Standards and regulations are subject to change at any time.

Careful consideration should be given to the requirements of the Americans with Disabilities Act (ADA), US Code 28 CFR (see Section 305).

In compliance with the ADA (American Disabilities Act) there must be clear floor space of at least 30 inches by 48 inches and be served by an accessible route for at least one of each type of exercise equipment. If the clear space is enclosed on three sides (e.g., by walls or the equipment itself), the clear space must be 36 inches by 48 inches.

**Important:** These spacing recommendations should be used when positioning equipment away from sources of heat, such as radiators, heat registers, and stoves. Avoid temperature extremes.

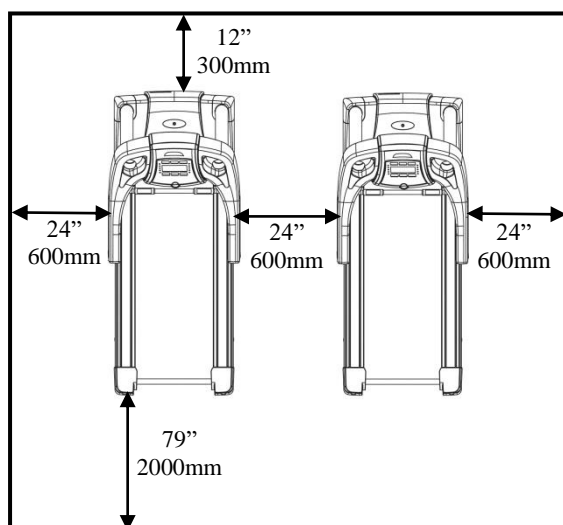

# SAFETY PRECAUTIONS

## Environment

The unit is designed to function normally in an environment with a relative humidity range of 30% to 75%. The unit can be shipped and stored in a relative humidity range of 10% to 90%. Climatic dry air may cause static electricity. During a workout, a user may experience a shock due to a buildup of static electricity on the body and the discharge path of the unit. If static electricity is experienced, increase humidity to a comfortable level through the use of a humidifier.

## Temperature

The unit is designed to function in an environment with an ambient temperature range of 50°F (10°C) to 104°F (40°C). The unit can be shipped and stored in an environment with an ambient temperature range of 32°F (0°C) to 140°F (60°C).

## Electrical Power Requirements

The power requirements for this treadmill are a grounded, dedicated circuit rated for the following:

- 115 VAC, 50/60 HZ, 20A



Shock and electrocution hazard.

- Connect unit to a grounded outlet.
- Do not use a voltage adapter or extension cord.

### • Important Voltage Information

- Before plugging the power cord into an electrical outlet, verify that the voltage requirements for your area match the voltage of the treadmill that you have received. The power requirements for the treadmill include a grounded, dedicated circuit, rated for one of the following figure. See the serial number decal for the exact voltage requirements of your treadmill.
- **WARNING: Don't attempt to use this unit with an unapproved voltage adapter. All voltage adapters **MUST** be approved and supplied by Green Series Fitness prior to use.**
- Don't attempt to use this unit with an extension cord which does not meet Green Series Fitness criteria of the following; 12 gauge SO3, maximum of 25 foot length with a 20 amp rating.

## Grounding Instructions

This equipment must be grounded. If it should malfunction or break down, grounding provides a path of least resistance for electric current to reduce the risk of electric shock.

This equipment is equipped with a cord having an equipment-grounding conductor and a grounding plug. The plug must be plugged into an appropriate outlet that is properly installed and grounded in accordance with all local codes and ordinances. Please make sure that the equipment is connected to an outlet having the same configuration as the plug. Do not use a ground plug adapter to adapt the power cord to a non-grounded outlet.

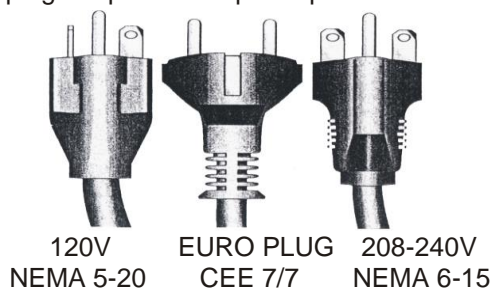

The power requirements for the equipment includes a grounded, dedicated circuit, rated for one of the following:

- 120 VAC 5%, 60HZ and 20 amps;
- 208/240 VAC, 60HZ, 15 amps
- 240 VAC 5%, 50HZ and 15amps.

# SAFETY PRECAUTIONS

## Waste Disposal

Products are recyclable. At the end of its useful life please dispose of this article correctly and safely (local refuse sites).



- The running belt must be set up on firm even ground. Ensure that the power cable is not pinched and that one can trip over it.
- Never touch the moving belt with your hands. Also ensure that there are no objects close to the belt or the rollers which could be pulled into it thus causing injury or damaging the unit itself.
- Repairs on the electrical components in the unit should be carried out by qualified persons only.
- The treadmill has an emergency stop mechanism for your safety. Before starting your workout, fasten the cord of the safety key to your clothing. If the treadmill has been shut down by removing the safety key, restart it by reinserting the key. An automatic restart of the treadmill belt does not occur. Further instructions concerning the handling of the safety cut-out can be found in the operating instructions for the training computer.

Thank you for your purchasing our products. Even though we go to great efforts to ensure the quality of each product, occasional error, and/or omissions do occur. In any event should you find this product to be defective or missing parts please contact us.

**IMPORTANT: Read all instructions and warnings before assembly and operation.**

## **IMPORTANT SAFETY INSTRUCTIONS**

When using equipment, basic precautions should always be followed, including the following:  
Read all instructions before using the Treadmill.

**DANGER** - To reduce the risk of electric shock: Always unplug this appliance from the electrical outlet immediately after using and before cleaning.

**WARNING** - To reduce the risk of burns, fire, electric shock, or injury to persons:

1. The equipment should never be left unattended when plugged in. Unplug from outlet when not in use and before putting on or taking off parts.
2. Close supervision is necessary when the equipment is used by, on, or near children, invalids, or disabled persons.
3. Use the equipment only for its intended use as described in this manual. Do not use attachments not recommended by the manufacture.
4. Never operate the equipment if it has a damaged cord or plug, if it is not working properly, if it has been dropped or damaged, or dropped into water. Return the equipment to a service center for examination and repair.
5. Do not carry the equipment by supply cord or use cord as a handle.
6. Keep the cord away from heated surfaces.
7. Never operate the equipment with the air openings blocked. Keep the air openings free of lint, hair, and the like.
8. Never drop or insert any object into any opening.
9. Do not use outdoors.
10. Do not operate where aerosol (spray) products are being used or where oxygen is being administered.
11. To disconnect, turn all controls to the **OFF** position, then remove plug from outlet.
12. Connect the equipment to a properly grounded outlet only. See Grounding Instructions.
13. The equipment is intended for commercial use.
14. Store the safety key in a secured location while not in use and keep away from children.
15. Maximum user weight: 450lbs (204 kg) .

# SAFETY PRECAUTIONS

## **EMERGENCY DISMOUNT:**

In case you must leave the equipment in an EMERGENCY SITUATION, grab the handrail and set both feet on the right and left foot platform beside the running belt. Now you pull out the safety switch, in order to slow down the equipment.

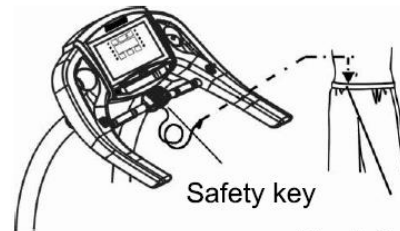

Attach the safety key to your waist.

## **The function of the immobilization method:**

If you would like to stop the equipment, then you can stop it either with the switch on the console or pull out the safety switch. If you pull the safety switch, in this case the computer shut down all functions automatically and the running belt slow down immediately.

## **SAFETY KEY**

Check if the safety key at the console and the clip at your clothes are secured. The safety key is intended for interrupting the main connection in case you should fall. Thus, it was developed to bring the equipment to an immediate stop. For higher speeds this can be unpleasant and somewhat dangerous as well. Please only use the safety key for an emergency stop. In order to stop the equipment during training under normal circumstances in a safe, comfortable and complete manner, use the **STOP** button.

## **ENTER AND LEAVE THE TREADMILL**

Be careful when entering and leaving the treadmill. Use the handle bars. Do not position yourself on the treadmill when preparing the use. Spread your feet and put them on the two side platforms next to the running surface. Put your feet on the treadmill only if it has started moving at constant speed. For your own safety, only enter the treadmill if it is not running faster than 2 km/h. Always look to the front during the training sessions. Never try to turn around on the treadmill as long as the treadmill is activated. After having finished your training session, you can stop the treadmill by pressing the **STOP** button. Wait until the treadmill has stopped completely before trying to leave the treadmill. In case you feel unsure regarding the speed you should hold on to the handle bars, lift your feet from the treadmill, and position yourself on the side platforms next to the running surface. These side platforms are an appropriate position to relax before starting the training again. For your own safety and comfort, always start your training sessions at low speed.

## **CONSULT A PHYSICIAN IMMEDIATELY**

**Warning:** before starting any exercise program consult your physician. This is especially important for individuals over the age of 35 or persons with preexisting health problems. Read all instructions before using any fitness equipment. We assume no responsibility for personal injury damage sustained by or through the use of this treadmill.

## **How often you exercise:**

You should exercise three to four times a week to improve your cardiovascular and muscle fitness.

## **How hard you exercise:**

Intensity of exercise is reflected in your heart rate. Exercise must be sufficiently rigorous to strengthen your heart muscle and condition your cardiovascular system. Only your doctor can prescribe the target training heart range for you. Before starting any exercise program consult your physician.

## **How long you exercise:**

Sustained exercise conditions your heart, lungs and muscles. The longer you are able to sustain exercise within your target heart range, the greater the aerobic benefits. To begin maintain 2~3 minutes of steady, rhythmic exercise, then check your heart rate.

# SAFETY PRECAUTIONS

## **EMERGENCY DISMOUNT:**

In case you must leave the equipment in an **EMERGENCY SITUATION**, grab the handrail and set both feet on the right and left foot platform beside the running belt. Now you pull out the **SAFETY KEY** from the console to slow down and stop the equipment.



Attach the safety key to your waist.

## **The function of the immobilization method:**

If you would like to stop the equipment, then you can stop it either with the **STOP** switch on the console or pull out the **SAFETY KEY** from the console. If you pull the **SAFETY KEY** from the console, this case the computer shut down all functions automatically and the running belt slow down and come to a stop immediately.

## **SAFETY KEY**

Check if the **SAFETY KEY** at the treadmill and the clip at your clothes are secured. The **SAFETY KEY** is intended for interrupting the mains connection in case you should fall. Thus, it was developed to bring the treadmill to an immediate stop. For higher speeds this can be unpleasant and somewhat dangerous as well. Please only use the **SAFETY KEY** for an emergency stop. In order to stop the treadmill during training under normal circumstances in a safe, comfortable and complete manner, use the **STOP** button.

## **ENTER AND LEAVE THE TREADMILL**

Be careful when entering and leaving the treadmill. Use the handle bars. Do not position yourself on the treadmill when preparing the use. Spread your feet and put them on the two side platforms next to the running surface. Put your feet on the treadmill only if it has started moving at constant speed. For your own safety, only enter the treadmill if it is not running faster than 2 km/h. Always look to the front during the training sessions. Never try to turn around on the treadmill as long as the treadmill is activated. After having finished your training session, you can stop the treadmill by pressing the **STOP** button. Wait until the treadmill has stopped completely before trying to leave the treadmill. In case you feel unsure regarding the speed you should hold on to the handle bars, lift your feet from the treadmill, and position yourself on the side platforms next to the running surface. These side platforms are an appropriate position to relax before starting the training again. For your own safety and comfort, always start your training sessions at low speed.

# SAFETY PRECAUTIONS

## CONSULT A PHYSICIAN IMMEDIATELY

**Warning:** before starting any exercise program consult your physician. This is especially important for individuals over the age of 35 or persons with preexisting health problems. Read all instructions before using any fitness equipment. We assume no responsibility for personal injury damage sustained by or through the use of this treadmill.

## How often you exercise:

You should exercise three to four times a week to improve your cardiovascular and muscle fitness.

## How hard you exercise:

Intensity of exercise is reflected in your heart rate. Exercise must be sufficiently rigorous to strengthen your heart muscle and condition your cardiovascular system. Only your doctor can prescribe the target training heart range for you. Before starting any exercise program consult your physician.

## How long you exercise:

Sustained exercise conditions your heart, lungs and muscles. The longer you are able to sustain exercise within your target heart range, the greater the aerobic benefits. To begin maintain 2~3 minutes of steady, rhythmic exercise, then check your heart rate.

## Emergency Stop switch

The function of the **EMERGENCY STOP** is to help the user to get off the treadmill safely in case of an emergency. In case of emergency, press the **STOP** key, hold the handrails and get off when the belt stops.

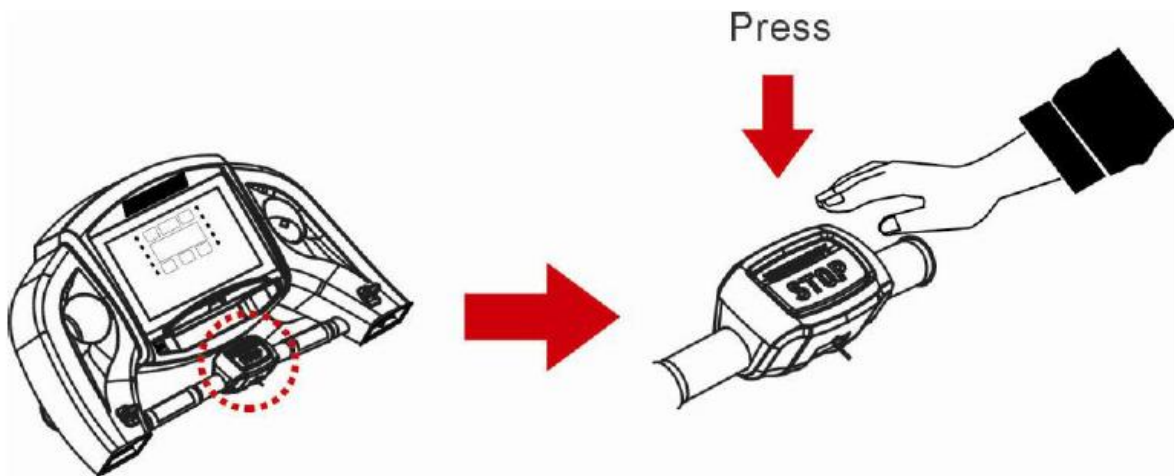



# PRECAUTIONS

## BEGINNER TREADMILL PROGRAM

	EXERTION LEVEL	DURATION
WEEK 1	Easy	6~12 minutes
WEEK 2	Easy	10~16 minutes
WEEK 3	Moderate	14~20 minutes
WEEK 4	Moderate	18~24 minutes
WEEK 5	Moderate	22~28 minutes
WEEK 6	Slightly higher or slightly lower	20 minutes
WEEK 7	Add interval training	3 minutes at moderate exertion with 3 minutes at higher exertion for 24 minutes

## TARGET HEART RATE ZONE

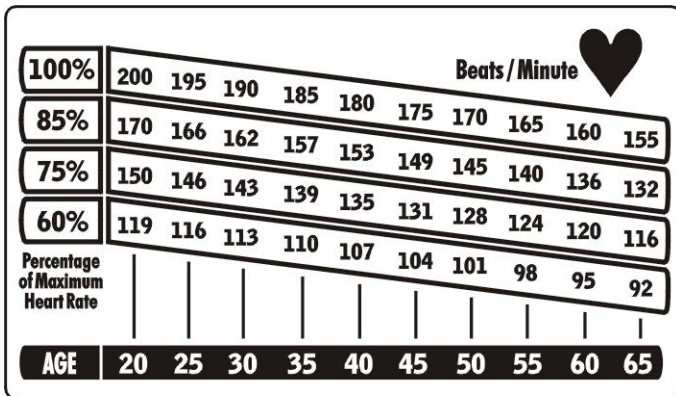

You do not want to workout at your maximum heart rate. The recommended Heart Rate Zone is a percentage of your maximum heart rate. Between 65% and 80% of your maximum heart rate.

\* Lower limit of Target Heart Rate Zone = maximum heart rate X 0.6

\* Upper limit of Target Heart Rate Zone = Maximum heart rate X 0.8

(This is recommended by American Heart Association. Before starting exercise program, please consult your physician to understand your physical situation)

- 100%** Increased Performance Range
- 85%** Aerobic Training Range
- 75%** Weight Loss Training Range
- 60%** Heart Rate BPM

220-your age = maximum heart zone

1\* Advantage of using the treadmill is consumers can strengthen the cardiopulmonary function and physical fitness.

\*This appliance is not intended for use by persons (including children) with reduced physical sensory or mental capabilities, or lack of experience and knowledge, unless they have been given supervision or instruction concerning use of the appliance by a person responsible for their safety.

\*The noise value list below is when it is at top speed with unloading status : LpAeq(dB) < 70dB

# TECHNICAL SPECIFICATIONS

## Serial Number Location:

The serial number contains 10 values. The location of the serial number is as shown below.



## SPECIFICATIONS:

**Length:** 83" (215 cm)

**Width:** 36" (92 cm)

**HEIGHT:** 57" (145 cm)

**Running area:** 22" c 60" (55cm x 154cm)

**Weight of product:** 356lbs (162 kg)

**User Weight Capacity:** 500lbs (227 kg)

**Speed Range:** 0.3 to 15.5 mph (0.48 to 25 km)

**Power elevation:** 0~18% motorized (front incline)

**Emergency stop:** Pull the safety key, press emergency stop switch.

**Programs:** 9 preset programs, 4HRC.

**Manual mode:** Yes

**Standard features:** Total used time, distance, heart rate, calories, speed, incline, hand pulse, fan, quick speed / incline button, Wireless HR receiver.

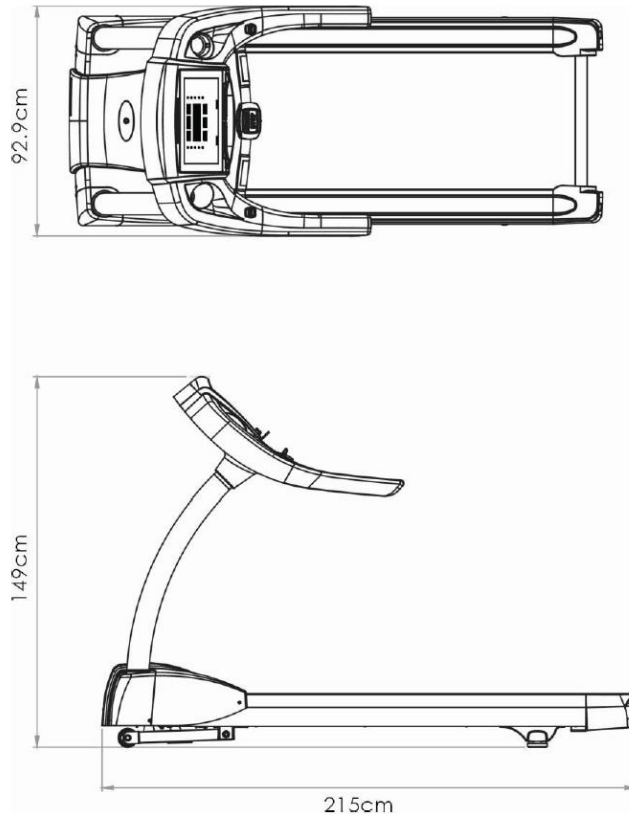

# UNPACKING & ASSEMBLY

## PARTS

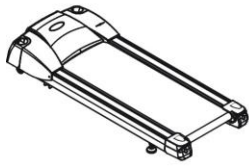

Main Body



Console

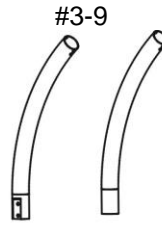

Console Mast Set

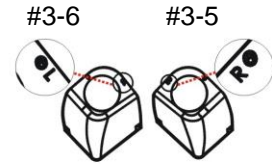

Left console mast cover (packaged in transparent bag)

Right console mast cover

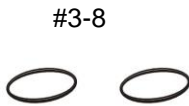

Packing

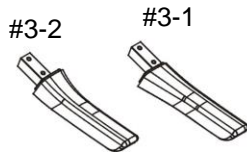



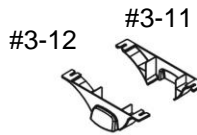







Handle bar set (left handlebar in transparent bag)



Adjustable pad cover

## HARDWARE KIT

Step 2	 #3-21 M12x30mm 6 pcs	 #3-22 M12 S Washer 6 pcs	 #3-23 M12 Washer 6 pcs
Step 4	 #3-3 M8x25mm 8 pcs	 #3-14 M12 S Washer 8 pcs	 #3-4 M12 Washer 8 pcs
Step 5	 #3-7 M5x15mm 4 pcs		
Step 6	 #3-3 M8x25mm 4 pcs	 #3-14 M8 S Washer 4 pcs	 #3-4 M8 Washer 4 pcs
Step 7	 #3-18 M3x12mm 1 pc		



#3-15  
End Cap 4pcs  
(lower Console)



Power Cord 1 pc



Allen Wrench  
1 pc (5mm)



Allen Wrench  
1 pc (6mm)



Allen Wrench  
1 pc (10mm)



#3-19  
Power Cord Locker  
(Power Cord) 1 pc

## UNPACKING & ASSEMBLY

**IMPORTANT:** Read all instructions and warnings before assembly and operation.

**This unit has been 100% assembled, tested for all functions including vibration sensors and then disassembled. Any misalignments causing stripped out threads is not covered by warranty due to installer not reinstalling correctly per the following steps #1 thru #8.**

Unpacking your treadmill where will be using it. Being careful not to damage. Place your treadmill on a level flat surface. It is recommended that you place a protective covering on your floor.

\*Notice: Because of heavy weight, please assemble this treadmill more than two people.

**Step1:** Loosen the motor cover screws, lift up and then set the motor cover aside.

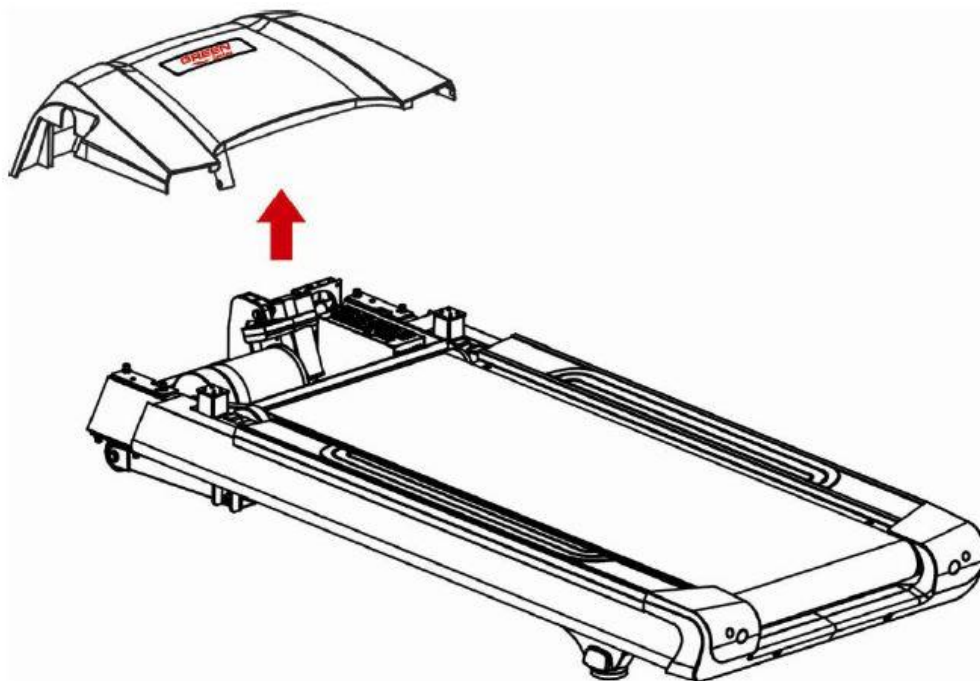

# UNPACKING & ASSEMBLY

## Step 2: Assemble the Console Mast

**WARNING:** The tightening sequence **MUST** be adhered to when performing assembly.

- 1) Place the Console Wire into the RIGHT MAST and route it through the bottom using the GUIDE WIRE. (The LEFT MAST is in the transparent bag.)
- 2) Slide the right console mast down on to the console mast support tube. Using an Allen wrench (6mm), secure using (6) M12x30mm bolts (#3-21) and (6) M12 S washers (#3-22) and (6) M8 washers (#3-23). **(Hand tighten the (6) M12x30mm bolts. Final tightening will occur in Step 4.4 and 4.5).**

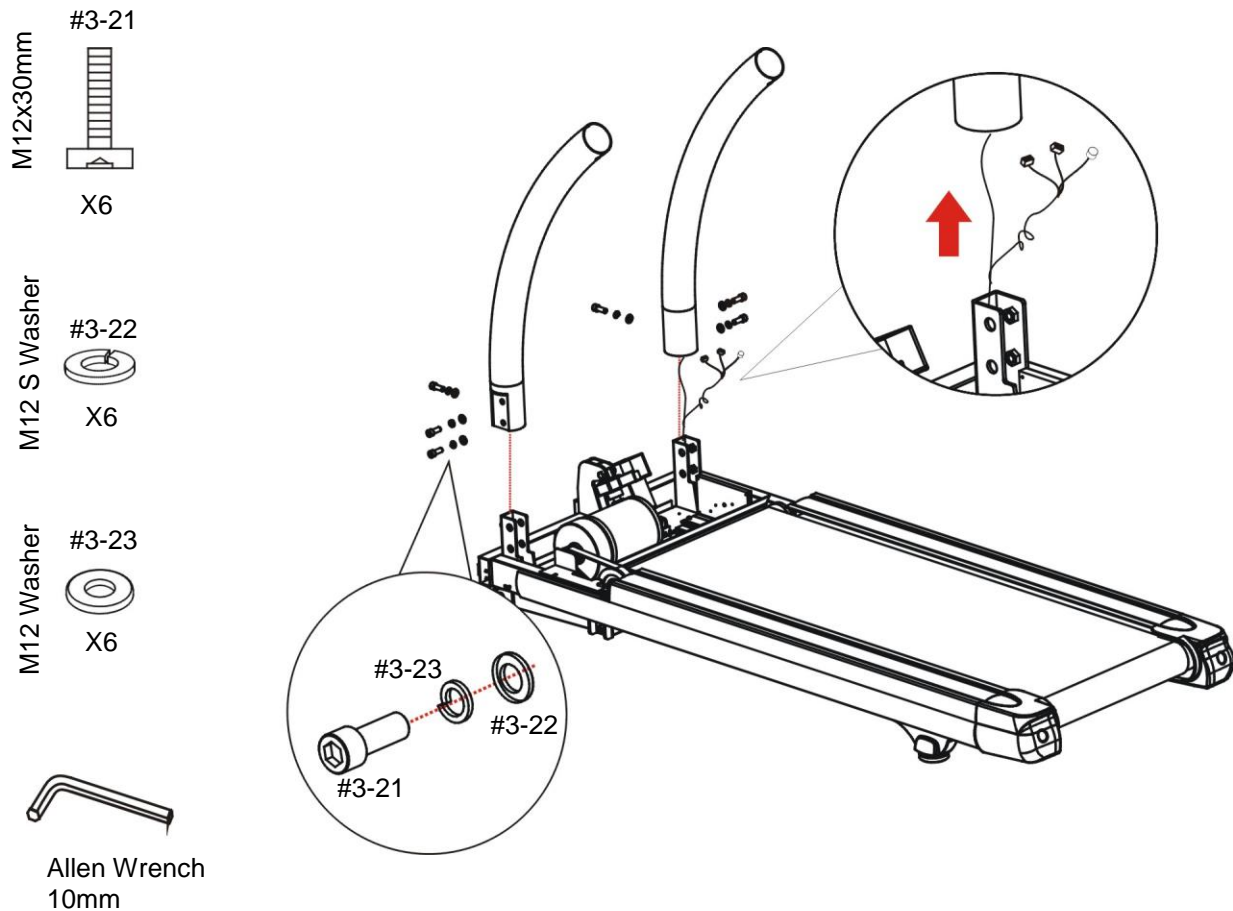

# UNPACKING & ASSEMBLY

## Step 3: Installing Covers onto Mast.

- 1) Slide the console mast cover (#3-5 and #3-6) and (2) packing (#3-8) onto two sides of console mast. **(Do not attach the console mast covers until Step 4.9).**

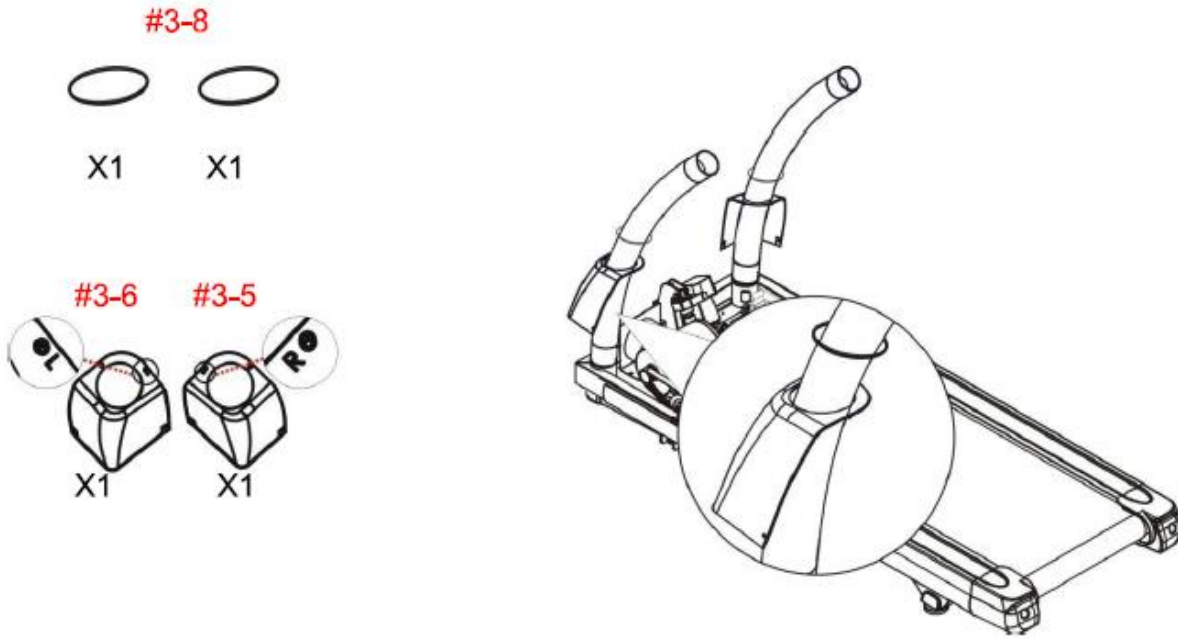

# UNPACKING & ASSEMBLY

## Step 4: Attach the console to the console mast.

- 1). Connect the right side of console cables and carefully tuck wires in mast to avoid damage.
- 2). Assemble the console onto the console mast.
- 3). Fasten console mast and console using the hex wrench with (8) (#3-19) M5x15mm bolts and (8) (#3-15) curve washers.

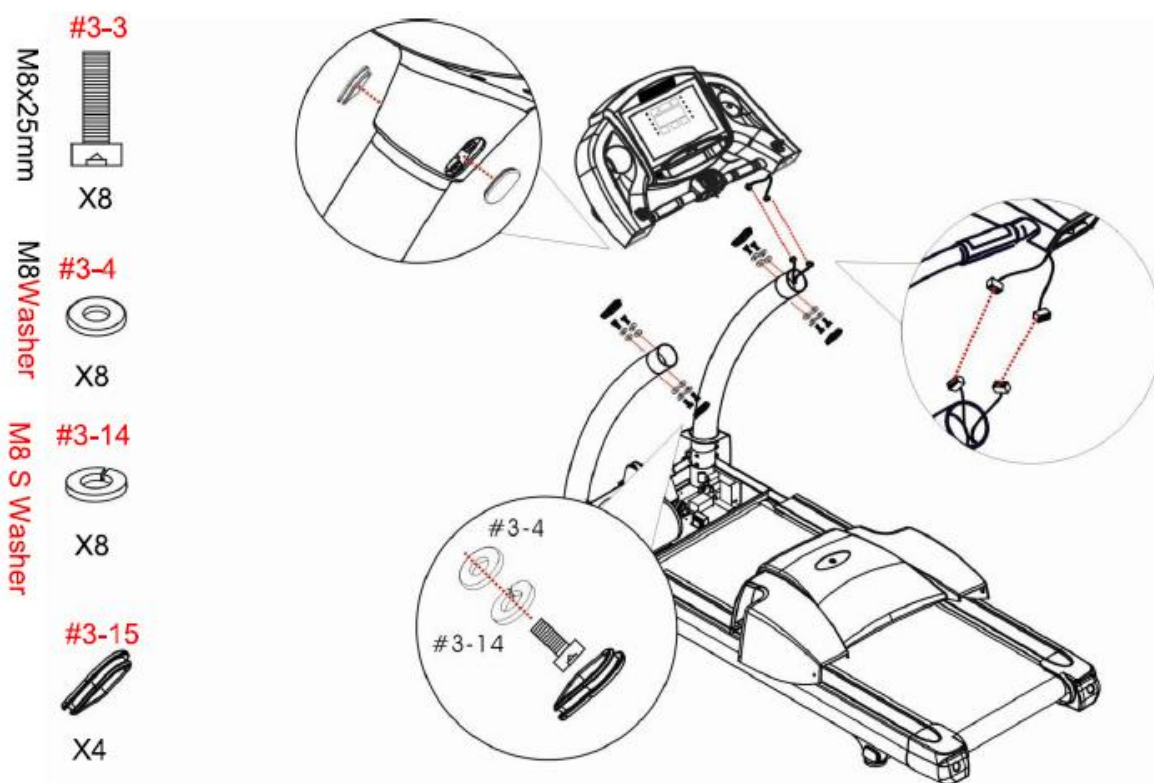

- 4). Using the T-Handle hex wrench, tighten the (10) bolts of console mast with base frame console tube.
- 5). While on the treadmill, facing the console, lift up and down vigorously on the handles with 50 to 100 pounds of force several times.

## UNPACKING & ASSEMBLY

- 6). Using a Torque wrench set to **20 ft/lbs**, tighten (8) (#3-17) bolts labeled “**A**”. The remaining (2) bolts (#3-17) located on the front of the console mast tubes, labeled “**B**”, shall be torqued to **15 ft/lbs**. Verify that the console mast is secure and tight by lifting up and down vigorously on the handles with 50 to 100 pounds of force several times. If needed, re-torque to the specifications outlined.

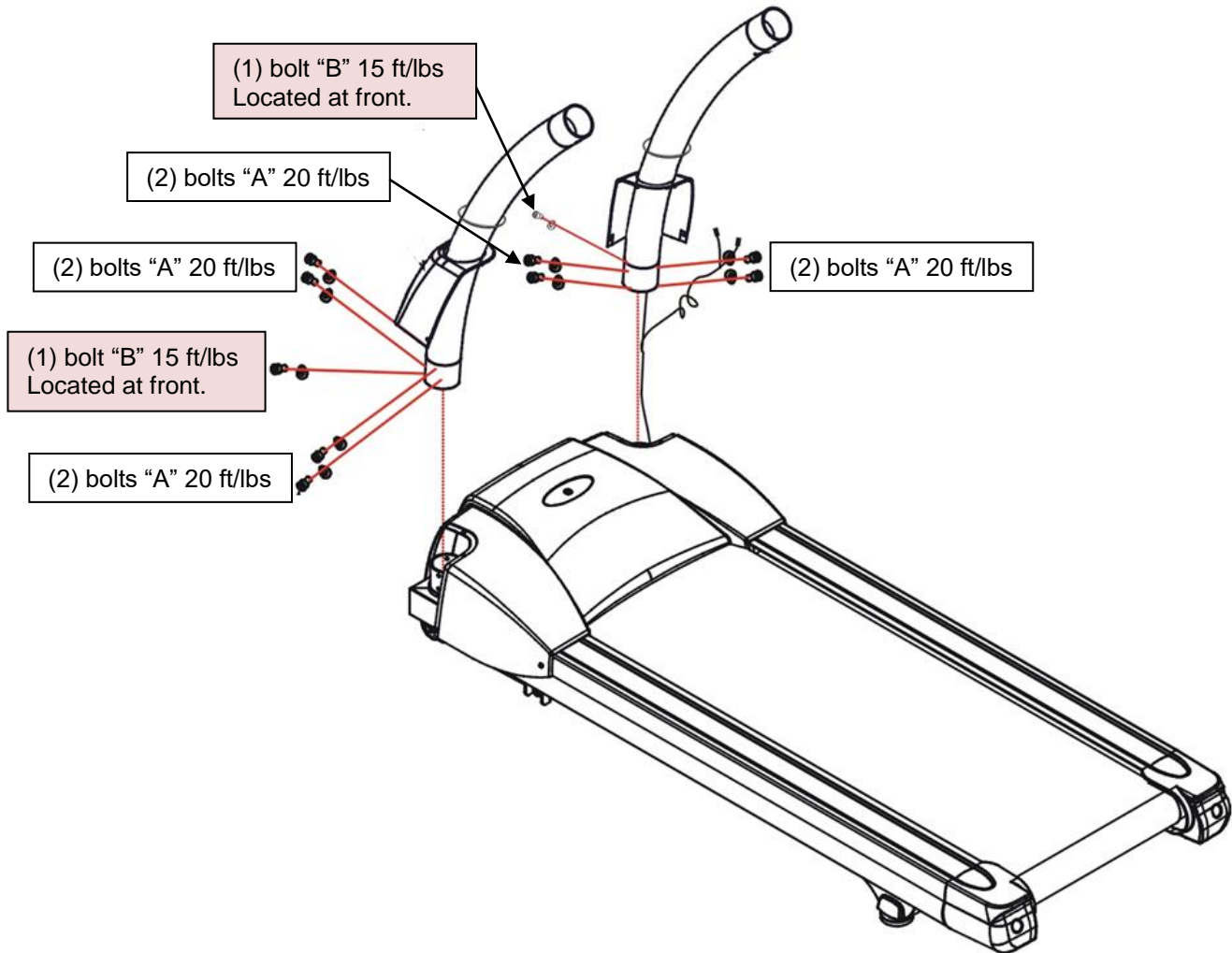

- 7). Re-check the handlebar bolts and the console mast to frame bolts to confirm that all of the bolts are set to **20 ft/lbs**.
- 8). Place (4) (#3-16) plastic caps into console lower cover.
- 9). Slide the (2) console mast covers (#3-5, #3-6) and (2) packing (#3-9) down, and secure using (4) M5x15mm screws.



# UNPACKING & ASSEMBLY

## Step 5: Assemble Handlebars to Console.

Step1: Slide handlebars onto console

- 1) Slide handlebar onto console, using an Allen wrench, install the (4) bolts M8x25mm and (4) M8 washers.
- 2) Using a Torque wrench set to **20 ft/lbs**, tighten the (4) bolts M8x25mm.
- 3) Verify that the Shifter paddles move freely. If the shift paddles bind, loosen the (4) bolts, M8x25mm, re-align the handlebars and then re-torque the (4) bolts to **20 ft/lbs**.

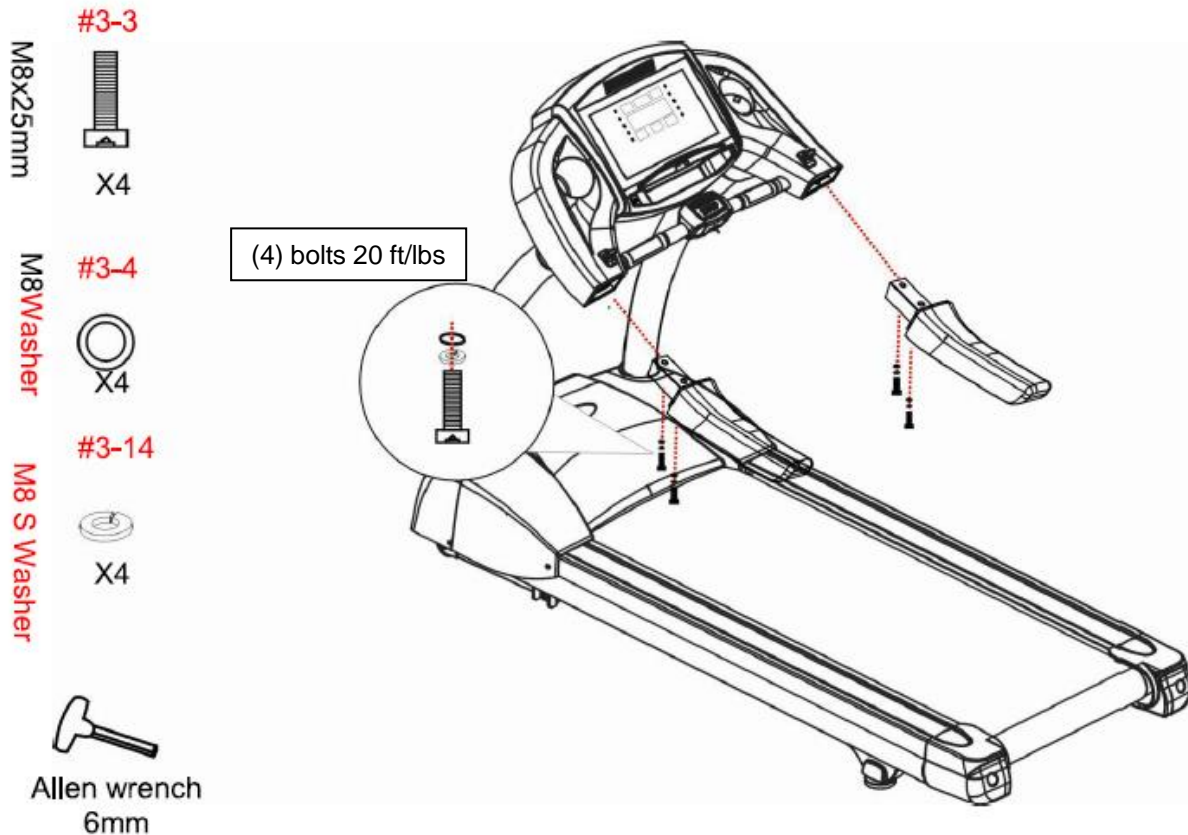

# UNPACKING & ASSEMBLY

## Step 6: Assemble Power Cord and Power Cord Locker.

- 1) Using a Phillips screwdriver, remove (1) M3 screw from the right side of the Power Cord Receptacle.
- 2) Plug in the Power Cord .
- 3) Fasten the Power Cord and Power Cord Locker (#3-17) using a Phillips screwdriver with (1) M3 x 12mm screw (M3-18).

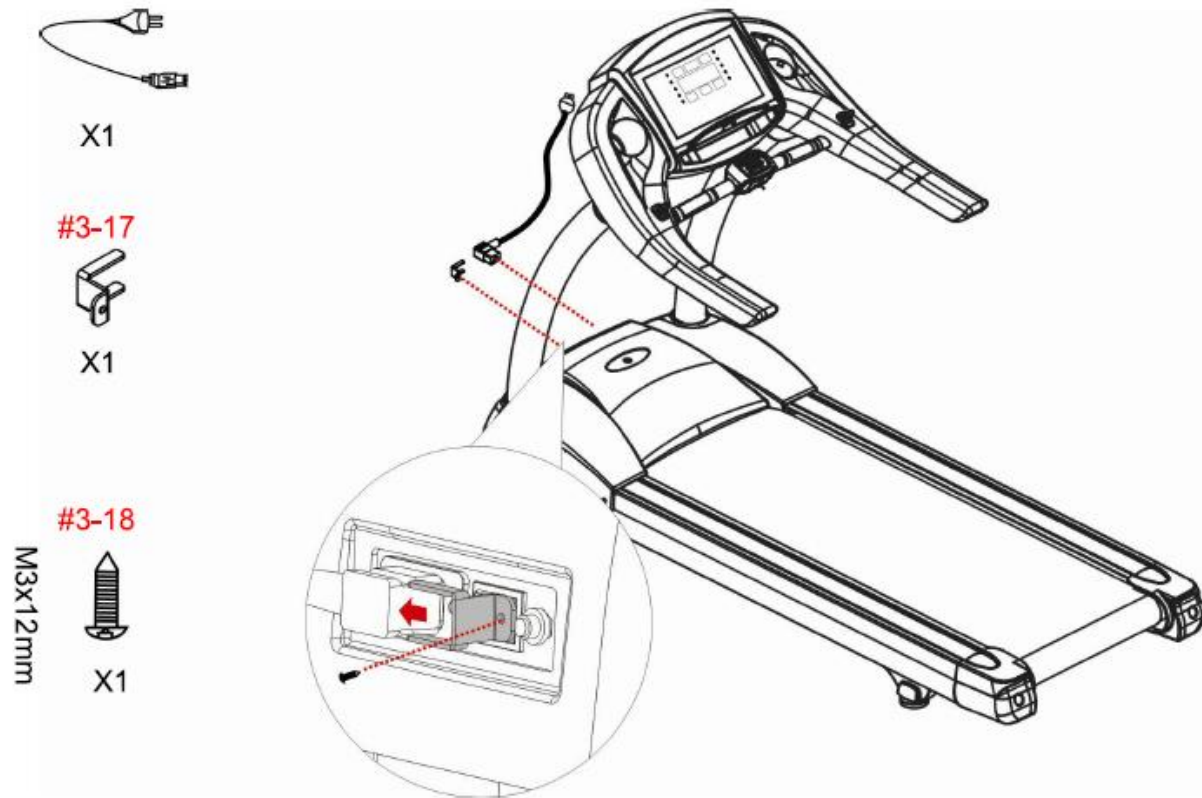

# WARM UP & COOL DOWN

A successful exercise program consists of a warm up, aerobic exercise and a cool down. Warming up is an important part of your workout, and should begin every session. It prepares your body for more strenuous exercise by heating up and stretching out your muscles. At the end of your workout, repeat these exercises to reduce sore muscle problems. We suggest the following warm-up and cool-down exercises:



## **HEAD ROLLS**

Rotate your head to the right for one count, feeling the stretch up the left side of your neck. Next rotate your head back for one count, stretching your chin to the ceiling and letting your mouth open. Rotate your head to the left for one count, and finally, drop your head to your chest for one count. Repeat this action for several times.



## **SHOULDER LIFTS**

Lift your right shoulder up toward your ear for one count. Then lift your left shoulder up for one count as you lower your right shoulder. Repeat this action for several times.



## **QUADRICEPS STRETCH**

With one hand against a wall for balance, reach behind you and pull your right foot up. Bring your heel as close to your buttocks as possible. Hold for 15 seconds and repeat with left foot up.



## **SIDE STRETCHES**

Open your arms to the side and continue lifting them until they are over your head. Reach your right arm as far upward toward the ceiling as you can for one count. Feel the stretch up your right side. Repeat this action with your left arm.

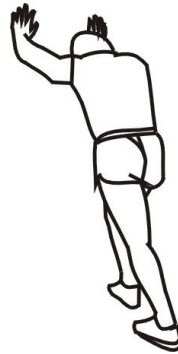

## **CALF/ACHILLES STRETCH**

Step your right foot in front of your body. Lean against a wall with your arms and stretch your left foot backward your body. Bend forwards your right foot, and slightly push your buttock toward to the wall for 15 seconds. Repeat the action with front left foot and rear right foot for another 15 seconds.



## **INNER THIGH STRETCH**

Sit with the soles of your feet together with your knees pointing outward. Pull your feet as close to your groin as possible. Gently push your knees toward the floor. Hold for 15 seconds. Repeat this action 3-5 times.



## **TOE TOUCHES**

Slowly bend forward from your waist, letting your back and shoulder relax as you stretch toward your toes. Reach down as far as you can and hold for 15 seconds.



## **HAMSTRING STRETCHES**

Keep your right leg straight and the left foot on the floor; try to stretch your right hand toward the toe, hold this posture for 15 seconds. Relax, and then repeat the action for left leg.

# PANEL CONTROL

## Display & Keys

Message window, display program profiles & message

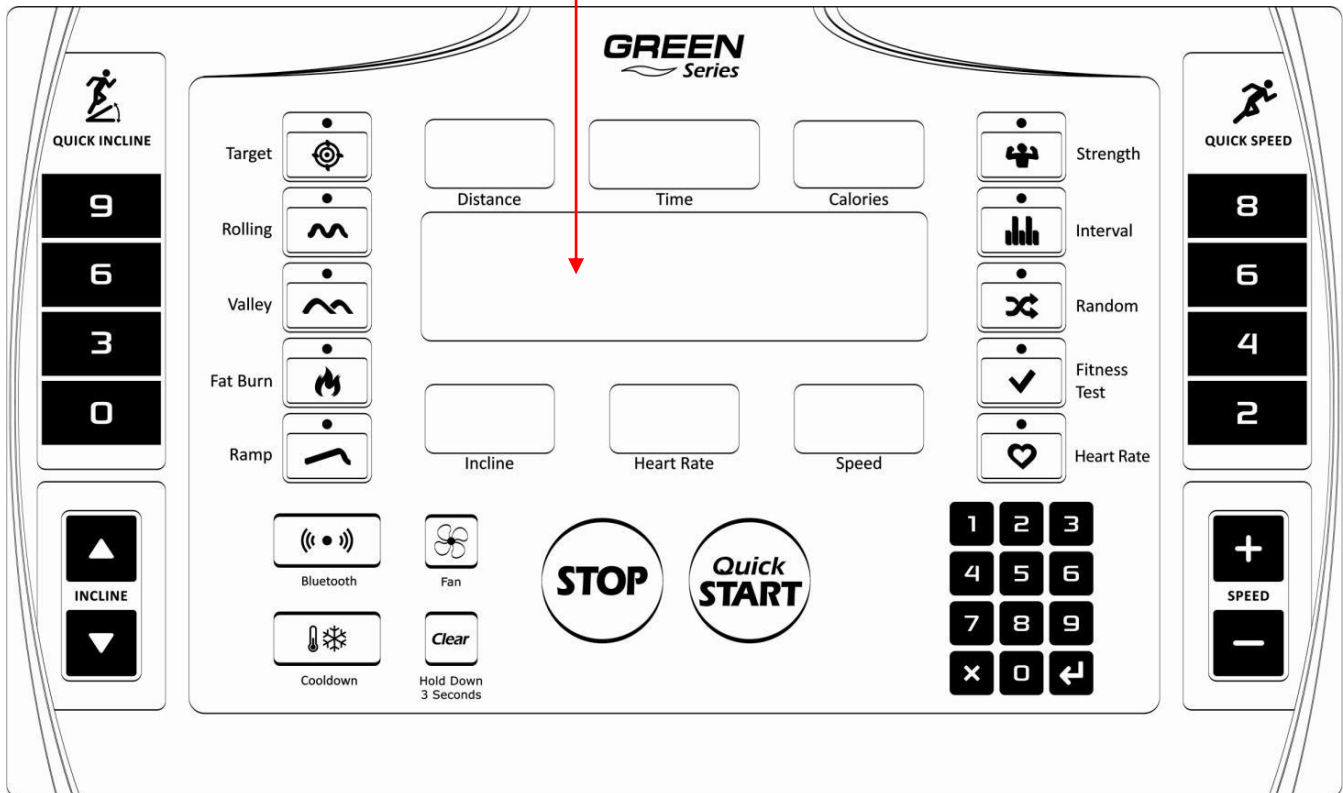

# PANEL CONTROL

## Display function

Display	Definition
<b>Time</b>	Displays time remaining or total time.
<b>Calories</b>	Displays calories burned.
<b>Incline</b>	Displays current incline level.
<b>Heart Rate</b>	Displays hand grip and wireless Heart Rate reading.
<b>Distance</b>	Displays total distance KM/Mi.
<b>Speed</b>	Displays the running speed.

## Key function

Key	Function
<b>Start</b>	Quick start or program start.
<b>Stop</b>	Press to pause when in use.
<b>Incline ▲</b>	Adjusts the incline while in use. Adjusts program types and program values.
<b>Incline ▼</b>	Adjusts the incline while in use. Adjusts program types and program values.
<b>Keypad 0~9</b>	Set the running speed while in use. Set program values.
<b>Rest / Clear</b>	Clear the setting value while setting.
<b>Enter</b>	Confirm value entered.
<b>Speed+</b>	Adjusts the speed while in use. Adjusts program types and program values.
<b>Speed –</b>	Adjusts the speed while in use. Adjusts program types and program values.
<b>Quick Speed</b>	Adjusts speed to a predetermined value. There are 4 speed quick keys.
<b>Quick Incline</b>	Adjusts incline to a predetermined value. There are 4 incline quick keys.
<b>Cool Down</b>	Program will gradually lower the speed.
<b>Program keys</b>	Select program directly.
<b>Fan</b>	To switch on / off the fan.
<b>Clear</b>	Hold for 3 seconds to Clear.

# PROGRAMS

## PROGRAMS



Target



Rolling



Valley



Fat Burn



Ramp



Strength



Interval



Random



Fitness Test



H.R.C

## Program operation :

### 1. 【Target】 :

1.1. Press 『Target』 key to select 【Target】 program.

1.1.1. Message window show 『SET BODYWEIGHT THEN PRESS ENTER』, set body weight then press 『ENTER』 to next setting.

1.1.2. Set time: Message window show 『SET TIME THEN PRESS ENTER』, set time then press 『ENTER』 to next setting.

1.1.3. Set distance: Message window show 『SET DISTANCE THEN PRESS ENTER』, set distance then press 『ENTER』 to next setting.

1.1.4. Set calories: Message window show 『SET CALORIES THEN PRESS ENTER』, set calories then press 『ENTER』 to next setting.

1.1.5. Set beginning speed, message window show 『SET BEGIN SPEED THEN PRESS ENTER』, press 『FAST』 or 『SLOW』 to set the beginning speed then press 『ENTER』 to next setting.

1.1.6. Set beginning incline, message window show 『SET BEGIN INCLINE THEN PRESS ENTER』, press 『UP』 or 『DOWN』 to set the beginning incline then press 『START』 to begin workout.

### 1.2. Beginning the workout:

1.2.1. If either, Time, Distance and Calories are set the program will count down. Once the preset value reaches 0 the program will end. If no goal is set the program will not end unless manually stopped.

# PROGRAMS

## 2. 【Preset Programs】:

2.1. Press program key to select a preset program, there are 7 preset program keys (ROLLING, VALLEY, FAT BURN, RAMP, STRENGTH, INTERVAL, RANDOM).

2.1.1. Message window show 『SET BODYWEIGHT THEN PRESS ENTER』· set body weight then press 『ENTER』 to next setting.

2.1.2. Set time: Message window show 『SET TIME THEN PRESS ENTER』· set time then press 『ENTER』to next setting.

2.1.3. Set target max speed: (Level)

2.1.4. Message window show program profile, press ▲ or ▼ to set target max speed (if select RANDOM program, Message window will show 『CHANGE PROFILE』 once, press ▲ or ▼ to change the profile randomly), press 『QUICK START』 to begin workout.

### 2.2. Beginning the workout:

2.2.1. The speed or incline will change automatically according to the program settings, if time is entered during setup then the segment time=time set / 32. You can use any speed or incline key to change speed or incline during your workout.

2.2.2. The program will end when the counter reaches 0.

### 2.3. Preset program profiles:

Preset program ( unit in %, speed=target max speed x speed% )

# PROGRAMS

Prog.	SEG	1	2	3	4	5	6	7	8	9	10	11	12	13
P1	speed	50	50	60	60	70	80	90	100	90	80	70	60	60
	incline	0	1	2	3	4	5	6	6	5	4	3	2	1
P2	speed	50	60	80	100	90	90	80	80	70	70	60	60	60
	incline	0	2	4	6	5	4	5	4	3	2	3	2	1
P3	speed	50	50	60	60	70	70	80	80	90	90	100	100	100
	incline	0	1	2	3	4	5	4	3	2	2	5	4	3
P4	speed	50	50	50	50	50	60	60	60	60	60	70	70	70
	incline	0	1	2	1	3	2	3	4	3	4	5	4	5
P5	speed	50	50	60	60	60	70	70	70	80	80	80	90	90
	incline	0	1	2	4	6	8	7	5	6	8	7	6	5
P6	speed	50	50	60	60	70	80	90	50	50	90	100	50	50
	incline	0	1	2	3	5	2	3	6	2	3	7	2	3

Prog.	SEG	14	15	16	17	18	19	20	21	22	23
P1	speed	70	80	90	100	100	90	80	80	70	70
	incline	2	3	4	5	6	5	4	3	2	1
P2	speed	50	50	50	50	50	50	60	60	70	70
	incline	2	1	2	3	2	3	4	3	4	5
P3	speed	100	100	100	100	100	100	100	100	100	100
	incline	5	5	3	3	3	4	5	4	4	3
P4	speed	70	70	80	80	80	80	100	90	90	80
	incline	4	5	6	5	6	5	4	5	3	4
P5	speed	100	100	100	100	100	90	90	80	80	80
	incline	4	3	3	4	3	6	5	4	3	3
P6	speed	60	70	90	50	50	80	90	50	50	80
	incline	8	2	3	5	3	7	2	3	8	2

Prog.	SEG	24	25	26	27	28	29	30	31	32
P1	speed	60	60	70	80	90	90	80	70	50
	incline	1	2	3	4	5	6	5	4	2
P2	speed	80	80	90	100	100	80	70	60	50
	incline	4	5	6	5	6	6	4	2	0
P3	speed	100	100	100	100	90	80	70	60	50
	incline	2	2	3	5	4	3	2	1	0
P4	speed	80	70	70	70	60	60	60	50	50
	incline	3	4	3	2	3	2	1	2	0
P5	speed	70	70	70	60	60	60	50	50	50
	incline	6	5	7	7	5	3	1	0	0
P6	speed	90	100	50	50	90	70	60	50	50
	incline	3	5	3	1	6	5	3	0	0

P1=ROLLING, default value 4 MPH/6KPH. P2=VALLEY, default value 4MPH/6KPH. P3=FAT BURN , default value 3 MPH/5KPH. P4=RAMP, default value 4 MPH/6KPH. P5=STRENGTH, default value 5 MPH/7KPH, P6=INTERVAL, default value 5 MPH/7KPH, P7=RANDOM.



# PROGRAMS

## 3. Fitness Test:

3.1. Press **『Fitness Test』** to select the program.

3.2. Message window show **『SET BODYWEIGHT THEN PRESS ENTER』** · set body weight then press **『ENTER』** to next setting.

3.3. Set age, message window show **『SET AGE THEN PRESS ENTER』** , set age then press **『ENTER』** to next setting.

3.4. Set gender, message window show **【SET GENDER THEN PRESS ENTER】** for 3 seconds then display **【MALE】** pattern, press FAST or SLOW or UP or DOWN to set gender then press **『ENTER』** to next setting.

3.5. Set beginning speed: message window show **『SET BEGIN SPEED THEN PRESS ENTER』**, press **『FAST』** or **『SLOW』** to set begin speed then press **『Start』** to begin workout.

3.6. Beginning the workout:

3.6.1. This program is testing your fitness condition, how far you can run in 12 minutes, you can use any speed key to change the speed during your workout, the incline function is not available.

3.6.2. The program will end when the counter reaches 0.

3.6.3. Test result : **【VERY GOOD】** , **【GOOD】** , **【AVERAGE】** , **【BAD】** , **【VERY BAD】**

3.6.4. show as below:

AGE	SEX	VERY GOOD	GOOD	AVERAGE	BAD	VERY BAD
13~14	Male	> 2.7 KM	2.4~2.7 KM	2.2~2.39 KM	2.1~2.19 KM	< 2.1 KM
	Female	> 2.0 KM	1.9~2.0 KM	1.6~1.89 KM	1.5~1.59 KM	< 1.5 KM
15~16	Male	> 2.8 KM	2.5~2.8 KM	2.3~2.49 KM	2.2~2.29 KM	< 2.2 KM
	Female	> 2.1 KM	2.0~2.1 KM	1.9~1.99 KM	1.6~1.89 KM	< 1.6 KM
17~20	Male	> 3.0 KM	2.7~3.0 KM	2.5~2.69 KM	2.3~2.49 KM	< 2.3 KM
	Female	> 2.3 KM	2.1~2.3 KM	1.8~2.09 KM	1.7~1.79 KM	< 1.7 KM
21~29	Male	> 2.8 KM	2.4~2.8 KM	2.2~2.39 KM	1.6~2.19 KM	< 1.6 KM
	Female	> 2.7 KM	2.2~2.7 KM	1.8~2.19 KM	1.5~1.79 KM	< 1.5 KM
30~39	Male	> 2.7 KM	2.3~2.7 KM	1.9~2.29 KM	1.5~1.89 KM	< 1.5 KM
	Female	> 2.5 KM	2.0~2.5 KM	1.7~1.99 KM	1.4~1.69 KM	< 1.4 KM
40~49	Male	> 2.5 KM	2.1~2.5 KM	1.7~2.09 KM	1.4~1.69 KM	< 1.4 KM
	Female	> 2.3 KM	1.9~2.3 KM	1.5~1.89 KM	1.2~1.49 KM	< 1.2 KM
Over 50	Male	> 2.4 KM	2.0~2.4 KM	1.6~1.99 KM	1.3~1.59 KM	< 1.3 KM
	Female	> 2.2 KM	1.7~2.2 KM	1.4~1.69 KM	1.1~1.39 KM	< 1.1 KM

# PROGRAMS

## 4. 【HRC】

4.1. HRC operate with chest belt only · will be reset to idle mode if no any heart rate signal input after 60 seconds.

4.2. Press **【HRC】 key to select the program** · message window show **【THR】**, press **『Fast』**、**『Slow』**、**『Up』**、**『Down』**

Key to select **【HRC 65%】**、**【HRC 75%】** or **【HRC 85%】** ,press **『ENTER』** to confirm and starting to settings.(HRC 65%=(220-Age)x 65% / 75%=(220-Age)x 75% / 85%=(220-Age)x 85%)

4.2.1. Selected **【THR】** :

4.2.1.1. Message window show **『SET TARGET HR THEN PRESS ENTER』** , set target HR then press **『Enter』** to next setting.

4.2.1.2. Message window show **『SET BODYWEIGHT THEN PRESS ENTER』** · set body weight then press **『ENTER』** to next setting.

4.2.1.3. Set time: Message window show **『SET TIME THEN PRESS ENTER』** · set time then press **『ENTER』** to next setting.

4.2.2. Selected **【HRC 60%】** or **【HRC 75%】** or **【HRC 85%】** :

4.2.2.1. Set age: Message window show **『SET AGE THEN PRESS ENTER』** · set age then press **『ENTER』** to next setting.

4.2.2.2. Message window show **『SET BODYWEIGHT THEN PRESS ENTER』** · set body weight then press **『ENTER』** to next setting.

4.2.2.3. Set time: Message window show **『SET TIME THEN PRESS ENTER』** · set time then press **『ENTER』** to next setting.

4.2.2.4. Set begin speed: Message window show **『SET BEGIN SPEED THEN PRESS ENTER』** , press **『Fast』** or **『Slow』** to set begin speed then press **『Enter』** to next setting.

4.2.2.5. Set begin incline: Message window show **『SET BEGIN INCLINE THEN PRESS ENTER』** , press **『Up』** or **『Down』** to set begin incline then press **『Start』** to begin workout.

4.2.3. Beginning the workout:

4.2.3.1. The program will compare the real time and preset target heart rate every 30 seconds to adjust incline until the actual heart rate is reaches within + or – 5 beats of the preset target heart rate.

4.2.3.2. During the program, if the actual pulse rate  $\leq$  target workout heart rate minus 5, will be increased one level every 30 seconds until the max. level.

4.2.3.3. During the program, if the actual pulse rate  $\geq$  target workout heart rate plus 5, will be decreased one level every 30 seconds until the min. level.

4.2.3.4 You can use any speed or incline key to change speed or incline during your workout.

4.2.3.5 The program will end when the counter reaches 0, then enter cool down.



**HOLD 3 SECONDS :**

5 Clear Function

5.1. Hold for 3 seconds to Clear.

5.2. Display shows “Clearing all information” and the program will return to initial setting. (Includes Calories, Distance, Time and Goal Bar. Speed and Incline will not change.)

5.3. Clear will not operate in Warm Up, Bluetooth, Cool Down and Fitness Test modes.

5.4. To avoid conflicts in programs, the following programs will still follow preset values for Speed and Incline once the Clear has been pressed: Rolling, Valley, Fatburn, Strength and Interval.

# OPERATION

## Quick Shift :

Speed Quick Shift: press Quick Shift up to increase speed or down to decrease speed.

Incline Quick Shift: press Quick Shift to incline or down to decline.

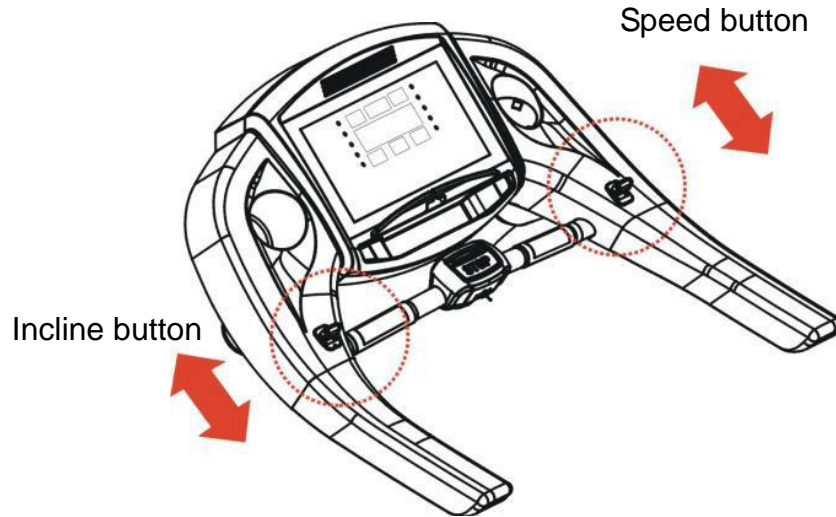

## FOLLOW THESE INSTRUCTIONS TO LEVEL YOUR TREADMILL:

An uneven floor or improper adjustable pad level can cause the treadmill to wobble during use as well as the incline adjustment to function incorrectly. Please follow the procedure described below to make sure the treadmill adjustable pad is adjusted correctly prior to use. You may need the assistance of another person to perform this adjustment.

**First locate the two adjustable pads under the running deck frame. Loosen the screws of adjustable pad cover, and remove the adjustable pad cover. Then simply rotate them in or out to adjust the level of the treadmill. When properly adjusted the treadmill should sit firmly on both adjustable pads and all cushions.**

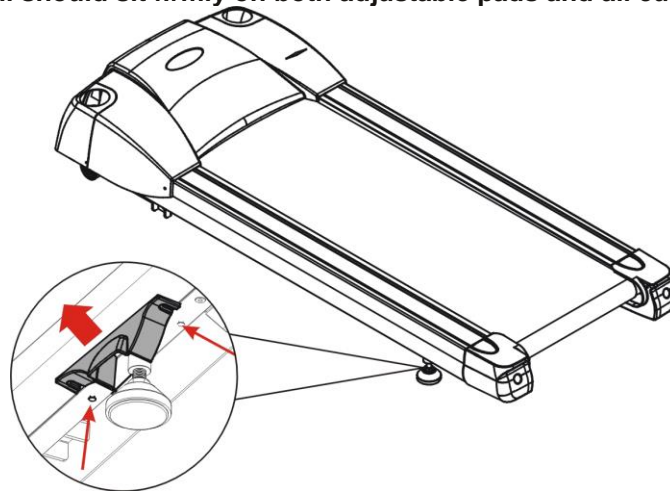

# BELT ADJUSTMENT

## **BELT ADJUSTMENT**

You may need to adjust the running belt during the first weeks of use. All running belts are properly set at the factory. It may stretch or be off-center after use. Stretching is normal during the break-in period.

## **ADJUSTING THE BELT TENSION**

If the running belt feel as though it is "slipping" or hesitating when you plant your foot during a run, the tension on the running belt may have to be increased. (Please spray silicone on deck first)

## **TO INCREASE THE RUNNING BELT TENSION**

- A). Place 6mm wrench on the left belt tension bolt. Turn the wrench clockwise 1/4 turn to draw the rear roller and increase the belt tension.
- B). Repeat STEP "A" for the right belt tension bolt. You must be sure to run both bolts the same number of turns, so the rear roller will stay square relative to the frame.
- C). Repeat STEP "A" and STEP "B" until the slipping is eliminated.
- D). Be careful not to tighten the running belt tension too much as you can create excessively pressure on the front and rear roller bearings. An excessively tightened running belt may damage the roller bearings that would result in bearing noise from the front and rear rollers.

## **TO DECREASE THE TENSION ON THE RUNNING BELT, TURN BOTH BOLTS COUNTERCLOCKWISE THE SAME NUMBER OF TURNS.**

## **CENTERING THE RUNNING BELT**

When you run, you may push off harder with one foot than with another. The severity of the deflection depends on the amount of force that one foot exerts in the relation to the other. This deflection can cause the belt to move off-center. This deflection is normal and the running belt will be balanced or no body is on the running belt. If the running belt remains consistently off-center, you will need to center the running belt manually.

- A). Start the treadmill without anyone on the running belt, press (SPEED UP ) button until speed reached 4 mph (6kph).
- B). Observe whether the running belt is toward the right or left side of the deck.

### ***a. If toward the left side of the deck:***

Using wrench, turn the left adjustment bolt clockwise 1/4 turn and the right adjustment bolt counterclockwise 1/4.

### ***b. If toward the right side of the deck:***

Using wrench, turn the right adjustment bolt clockwise 1/4 turn and the left adjustment bolt counterclockwise 1/4.

c. If the belt is still not centered, repeats the above steps until the running belt is on center.

C). After the belt is centered, increase the speed to 10 mph (16kph) and verify that it is running smoothly. Repeat the above steps if it is necessary. If the above procedure is unsuccessful in resolving the off-center, you may need to increase the belt tension.

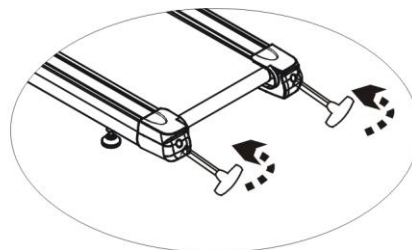
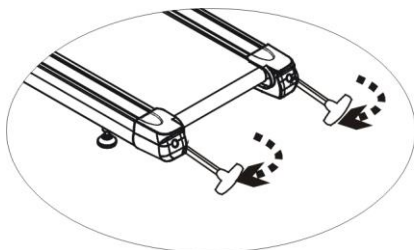

Turn counter-clockwise to decrease  
the running belt tension

## CARE & MAINTENANCE

### CARE & MAINTENANCE

Always remove the key and unplug the power cord before cleaning, lubricating, or performing any maintenance.

Other parts maintenance:

Number	Checking Item	Daily	Week	Month	Season	6 Months
1	Console Screws					Checking
2	Frame	Wipe				Checking
3	Running Surface		Clean(dust)			Checking
4	Power Code			Checking		
5	Overlay	Wipe		Checking		
6	Handle bar	Wipe				Checking
7	Handle bar screws				Checking	
8	Front Roller & Groove				Wipe	Checking
9	Rear Roller					Checking
10	Safety Key	Wipe				
11	Drive Belt				Wipe	Checking
12	Running belt tension					Checking
13	Motor Control					Clean(dust)
14	Motor Pulley & Groove					Checking

#### Running Belt Travel Area:

The running belt should be centered and adjusted within the area which has been indicated by the arrows on right roller cover and left roller cover. The running belt can be worn and damaged if the running belt travels beyond this scope.

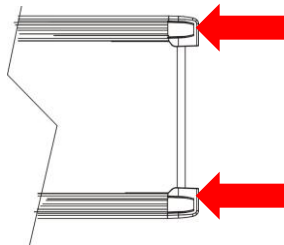

# CARE & MAINTENANCE

## CARE & MAINTENANCE

Always remove the key and unplug the power cord before cleaning, lubricating, or performing any maintenance.

### HOW DO I CLEAN MY MACHINE?

Clean with soap and water cleaners only. Never use solvents on plastic parts. Cleanliness of your treadmill and its operating environment will keep maintenance problems and service calls to a minimum. For this reason, Customer Tech Support recommends that the following preventive maintenance schedule be followed.

#### DAILY

- Unplug the treadmill. Clean entire machine using water and a mild soap or other Green Series Fitness approved solution (cleaning agents should be alcohol and ammonia free).

#### MONTHLY or QUARTERLY (depending on usage or dirty environments)

- Unplug the treadmill and remove the motor cover. Check for debris and clean with a dry cloth and small vacuum nozzle. **DO NOT** vacuum directly on electronics board. Either blow with mouth or compressed air to clean electronic components.

**WARNING:** Do not plug the treadmill in until the motor cover has been reinstalled.

#### RECOMMENDED CLEANING TIPS

Preventative maintenance and daily cleaning will prolong the life and look of your equipment.

- A Use a soft, clean cotton cloth. **DO NOT** use paper towels to clean surfaces on the treadmill. Paper towels are abrasive and can damage surfaces.
- B Use a mild soap and damp cloth. **DO NOT** use ammonia based cleaner or alcohol. This will cause discoloring of the aluminum and plastics it comes into contact with.
- C Do not pour water or cleaning solutions on any surface. This could cause electrocution.
- D Wipe the console, heart rate grip, handles and side rails after each use.
- E Brush away any wax deposits from the deck and belt area. This is a common occurrence until the wax is worked into the belt material.
- F Be sure to remove any obstructions from the path of the elevation wheels including power cords.
- G For cleaning console displays, use distilled water in an atomizer spray bottle. Spray distilled water onto soft, clean, dry cloth and wipe display until clean and dry. For very dirty displays, adding vinegar is recommended.

**CAUTION:** Be sure to have proper assistance to install and move the unit in order to avoid injury or damage to the treadmill.

# CARE & MAINTENANCE

## CHECK FOR DAMAGED PARTS

**DO NOT** use any equipment that is damaged or has worn or broken parts. Use only replacement parts supplied by Green Series Fitness.

**MAINTAIN LABELS AND NAMEPLATES** Do not remove labels for any reason. They contain important information. If unreadable or missing, contact Green Series Fitness for a replacement or an authorized service provider.

**MAINTAIN ALL EQUIPMENT** Preventative maintenance is the key to smooth operating equipment, as well as keeping the user's liability to a minimum. Maintain a clean area around the equipment, free from dust and dirt. Equipment needs to be inspected at regular intervals. Defective components must be replaced immediately. Improperly working equipment must be kept out of use until it is repaired. Ensure that any person(s) making adjustments or performing maintenance or repair of any kind is qualified to do so.

## DECK AND BELT REPLACEMENT

One of the most common wear and tear items on a treadmill is the deck and belt combination. If these two items are not properly maintained they can cause damage to other components. This product has been provided with the most advanced maintenance free lubricating system on the market.

**WARNING:** Do not run the treadmill while cleaning the belt and deck. This can cause serious injury and can damage the machine. Maintain the belt and deck by wiping the sides of the belt and deck with a clean cloth. The user can also wipe under the belt 2 inches (~51mm) on both sides removing any dust or debris. The deck can be flipped and reinstalled or replaced by an authorized service technician. Please contact Green Series Fitness for more information.

## STORAGE

Store your treadmill in a clean and dry environment. Ensure the master power switch is **OFF** and is unplugged from the electrical wall outlet.

## MOVING

This treadmill has been designed and equipped with wheels for easy mobility.

Before moving, ensure the master power switch is in the **OFF** position and the power cord is unplugged from the electrical outlet.

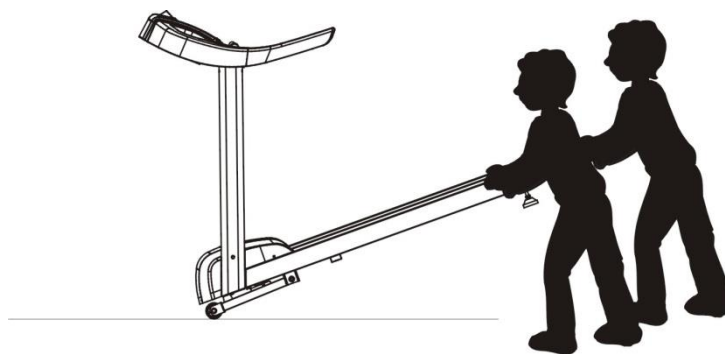

# TROUBLE SHOOTING

SYMPTOM	CAUSE	SOLUTION
Console display does not illuminate	A).No power to treadmill. B).Console wire is not connected or incompletely. C).Overload, protecting is started. D).Console power source damaged	A). Check the on-off switch is <b>ON</b> , switch indicator shall be on. if not, check AC power source. B). Check console wiring connector points are connected correctly, including outward and connector point insert PINs. C). Check fuse(near on-off switch) is working or not, if working, push it back, and restart again, if not working perform maintenance of the running belt and deck. D). Turn <b>OFF</b> power then open the motor cover, turn <b>ON</b> the power and check the console power pilot lamp(LED2) on the interface PCB, it shall be light completely, if not, replace it.
Display not completely showing	A). Console damaged. B). Console source power unstable.	A). Replace the console PCB. B). Turn <b>OFF</b> the ON/OFF switch, then open the motor cover. Turn <b>ON</b> the power again to see if the Console Power pilot lamp (LED1) on the interface PCB is completely lit. The interface needs to be changed if the interface power doesn't light up.

If the supply cord is damaged, it must be replaced by the manufacturer or its service provider or a similarly qualified person in order to avoid a hazard.

## Walking Belt Slipping, Jerking, Slowing

When a walking belt slips, jerks or slows when walking on it generally indicates a tension problem.

### Walking Belt:

The walking belt tension is different depending on the thickness of the walking belt. The thicker the belt, the looser it may be. Walking belt tension should be as loose as possible without slipping for the longest life span of the walking belt. Refer to the owner's manual for instructions on how to adjust the walking belt.

### Worn Walking Belt:

Walking belts have a grip system on the underside just like the top. If you have already adjusted the tension of the walking belt and it is still slipping, feel the underside of the walking belt. If the underside of the walking belt feels smooth, you may need to replace the walking belt.

### Lubricant:

Each new treadmill deck and walking belt comes pre-lubricated. To check for lubricant, run your fingers on the underside of the walking belt. If your fingers come out with a shiny gloss (not wet) there is plenty of lubricant. If it is rough and dry, a single application of **approved lubricant** may be applied to the walking belt. If the treadmill has been in storage or not used for an extended period of time, the lubricant may dry out and need a new application. Multiple applications of lubricant are **NOT** necessary and may result in damage to the walking belt and deck.

### Type of Lubricant:

Use only approved lubricant on the walking belt and deck. Green Series Fitness requires the use of **Silicon** lubricant. Using wax or spray type lubricant, or others, will result in a buildup of a sticky substance on the walking belt and deck. This buildup will result in the replacement of the walking belt and potentially the deck. **The usage of non-approved lubricants will result in the walking belt and deck warranty to be void.** It will be the responsibility of the customer to pay the costs associated for the parts and labor to replace such components.

## Treadmill Breaker or Main Service Breaker Tripping

### Worn Deck:

One of the indicators of a worn treadmill deck is the tripping of the treadmill breaker and/or the main service breakers. A worn treadmill deck causes additional resistance between the walking belt and the surface of the deck. This added resistance will cause an increase of the power required to operate the treadmill and potentially cause the power inverter and the walking belt to overheat thus causing the breakers to trip. With your hand, reach in between the walking belt and the deck. Feel the surface of the deck. If the deck is smooth and without "ridging", then the cause is likely elsewhere. If you or technician feels that the deck is rough to the touch or has ridges running the length of the deck, then the deck is likely the cause of the tripping breakers and the deck needs replacement.



# TROUBLE SHOOTING

## **Power Inverter or Lower Board:**

If it has been determined that the walking belt and deck are not the cause of the breakers tripping, then the next step is to verify the correct operation of the Power Inverter or lower board. If it is possible, exchange the power inverter with a power inverter of a treadmill which is not experiencing this problem. If the problem follows the exchanged power inverter, then replace the power inverter. If the problem does not follow the power inverter, then the problem is elsewhere and additional troubleshooting is required to locate the problem.

If you do not have another treadmill to exchange components with, feel the surface of the power inverter to determine if it is hot to the touch. If it is hot to the touch, replace the power inverter.

# ENGINEERING MODE

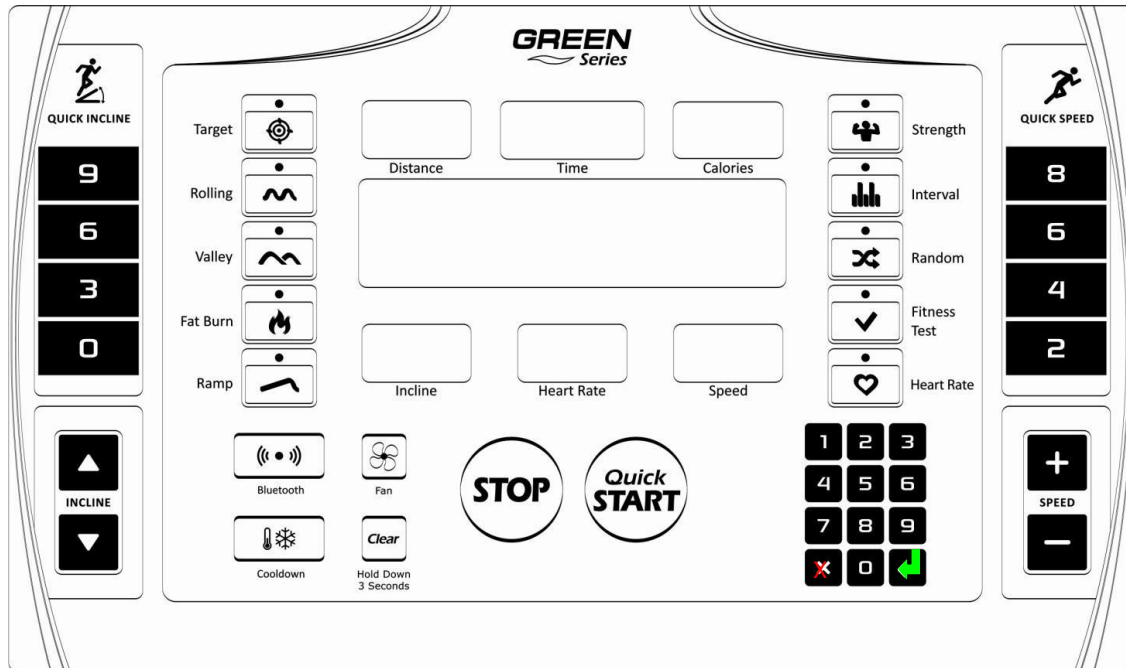

## 1. Engineering Mode

### 1.1. Configuration Mode 1: Test Mode

1.1.1. Press and hold **『Stop』** key then press **『Start』** for 3 to 5 seconds to enter the **Engineering Mode** while in idle mode. The display will show software version. Press **『Enter』** to begin the test mode.

**Scroll with the ENTER (Green back arrow  ) button.**

1.1.1.1. All displays will flash together, press **『Enter』** to proceed to next test mode.

1.1.1.2. **LED Scan mode** : this is for **Production Test Mode**, press **『Enter』** to proceed to next test mode.

1.1.1.3. **LED Pilot Lamp scan mode** : this is for **Production Test Mode**, press **『Enter』** to proceed to the next test mode.

1.1.1.4. **Keys Test mode** : dot-matrix show **【KEY】** , each key has its own code when pressing a key. The code show as below, press **『Enter』** to proceed to next test mode.

1.1.1.5. **Test Mode**: Press **Start** to begin, press speed keys to change speed, press incline keys to drive incline motor, press **『Enter』** to re-test, press and hold **『RESET/CLEAR』** then press **『Quick Start』** for 3 seconds to exit.

### 1.2. Configuration Mode 2: Factory Settings

1.2.1. Press and hold **『Stop』** key then press **『Speed +』** for 3 seconds to enter the **Engineering Mode** while in idle mode.

**Scroll with the ENTER (Green back arrow  ) button.**

1.2.1.1. **Software Version** : Dot-matrix shows **【VER】** , time window show software version, press **『Enter』** to proceed to next setting.

1.2.1.2. **SET LANGUAGE**: Dot-matrix shows **【SET LANGUAGE】** one time then show **『ENGLISH』** , press **▲** or **▼** change to **『NEDERLANDS』** or **『FRANCAIS』** or **『DEUTSCH』** or **『ITALIANO』** or **『ESPANOL』** ,

press 『ENTER』 to next setting. (This function is only for software versions greater than 1.09)

1.2.1.3. **SET UNIT:** Dot-matrix shows **【SET UNIT】** one time then shows 『METRIC』 , press ▲ or ▼ change to **【ENGLISH】** , press 『ENTER』 to proceed to next setting.

## ENGINEERING MODE

1.2.1.4. **FAN SETTING:** Dot-matrix shows **【FAN SETTING】** one time then shows 『ON』 , press ▲ or ▼ change to **【OFF】** , press 『ENTER』 to proceed to next setting.

1.2.1.5. **MIN SPEED:** Dot-matrix show **【SET MIN SPEED THEN PRESS ENTER】** , SPEED window shows value, press ▲ or ▼ to set value, press 『ENTER』 to proceed to next setting.

1.2.1.6. **MAX SPEED:** Dot-matrix shows **【SET MAX SPEED THEN PRESS ENTER】** , SPEED window shows value, press ▲ or ▼ to set value, press 『ENTER』 to proceed to next setting.

1.2.1.7. **MAX ELEVATION:** Dot-matrix shows **【SET MAX ELEVATION THEN PRESS ENTER】** , INCLINE window shows value, press ▲ or ▼ to set value, press 『ENTER』 to proceed to next setting.

1.2.1.8. **Total Used Distance:** Dot-matrix shows **【ODO】** , DISTANCE & TIME window shows total used distance. Total used distance= TIME window value + (DISTANCE window value X 10000) , press 『Reset/Clear』 + 『Enter』 for 5 seconds to erase total used distance value, press 『ENTER』 to proceed to next setting.

1.2.1.9. **Total Used Hours:** Dot-matrix shows **【HRS】** , TIME window shows total hours value, press 『Reset/Clear』 + 『Enter』 for 5 seconds to erase total used hours value, press 『Enter』 to go back to idle mode.

**Refer to the Engineering Service Manual for more detailed programming instructions.**

# PART LIST

ITEM	Part No.	DESCRIPTION	Q'TY	ITEM	Part No.	DESCRIPTION	Q'TY
1-1	H020801-002	Bolt M5x12L, roller cover/Wire set plate	6	<b>CONSOLE SET</b>			
1-2	H041013-000	Drive belt	1	2-1	F500199-001	Console frame	1
1-3	F205002-001	Right side rein	1	2-2	F300621-102	Upper console cover/K90	1
1-4	F205001-001	Left side rein	1	2-3	H020803-000	Screw M4x10L, Upper console cover	4
1-5	F500270-000	Running deck frame	1	2-4	H020202-004	Bolt M4x12L, Upper console cover	2
1-6	F880333-000	Incline rack set	1	2-5	F300622-102	Right Console Cover Rib /K90	1
1-6-1	F500193-002	Incline rack	1	2-6	F300623-102	Left Console Cover Rib /K90	1
1-6-2	F330030-000	Rubber piece	2	2-7	H020173-000	Bolt M4x12L, Console Cover Rib	14
1-6-3	H020626-003	Bolt M8x20L, Rubber piece	2	2-8	F300609-101	Bottle Holder /K90	1
1-6-4	F290051-001	Wheel axle center	2	2-9	F330075-000	Rubber Pad, Bottle Holder	3
1-6-5	F300346-000	Mobile wheel	2	2-10	H020252-000	Screw M4x10L, Bottle Holder	6
1-6-6	H021109-039	Washer, mobile wheel	4	2-11	F300310-103	Lower console cover /K90	1
1-6-7	H020302-017	Bolt M10x70L, mobile wheel	2	2-12	H020206-000	Screw M5x12L, Lower console cover	7
1-6-8	H022303-000	Nut M10	2	2-13	H020806-000	Bolt M4x10L, Lower console cover	2
1-6-9	H021205-000	S Washerϕ10.7xϕ16.9x2.2t mm	2	2-14	F300639-101	Upper Console Cover/K90	1
1-7	F060000-000	Bushing	2	2-15	F300625-102	Right Reading Rack /K90	1
1-8	H020674-001	Bolt 1/2"x3-1/4", lift arm	2	2-16	F300626-102	Left Reading Rack /K90	1
1-9	H022314-001	Bolt 1/2"x8t, lift arm	2	2-17	F373417-004	Panel, console	1
1-10	H020302-017	Bolt M10-70L , lift arm	1	2-18	H020201-002	Bolt M3x6L, Panel, console / Csafe	9
1-11	H022303-000	Nut M10, lift arm	6	2-19	F373387-000	BT board	1
1-12	F991009-003	Incline motor	1	2-20	F080198-000	BT cable	1
1-13	F300037-000	Incline motor Bushing	2	2-21	H020220-000	Bolt M2x5L , BT board	3
1-14	H020302-014	Bolt M10x45L, Incline motor	1	2-22	F880388-000	Hand Pulse Assembled Set /K90	1
1-15	F270246-002	Wire set plate	1	2-22-1	F500437-000	Hand pulse Set	1
1-16	F091001-001	Fuse	1	2-22-2	F300631-103	Emergency Stop Base /K90	1
1-17	H020118-001	Bolt M3x8L, wire set plate	2	2-22-3	F301012-000	Emergency Stop Cover	1
1-18	F376002-000	Electric socket	1	2-22-4	F373406-000	Emergency Stop Key	1
1-19	F090012-000	On-off switch	1	2-22-5	H020201-002	Screw M3x6L, Emergency Stop Cover	6
1-20	F994003-001	Motor	1	2-22-6	H021110-001	M4 washer, Emergency Stop Cover	2
1-21	F379001-000	Clip, motor	1	2-22-7	H020252-000	Screw M4x10L, Emergency Stop Cover	6
1-22	H020302-016	Bolt M10x30L, motor	4	2-22-8	H029114-101	Spring	2
1-23	F330033-000	Rubber plate, motor	1	2-22-9	F010504-001	Safety Key Thread	1
1-24	H020615-007	Bolt M10x25L, motor	4	2-22-10	F300632-102	Emergency Stop Lower Cover /K90	1
1-25	H021205-000	S Washer, motor	8	2-22-11	H020803-000	Screw M4x10L, Emergency Stop Lower	4
1-26	H021109-022	M10 washer, motor	12	2-22-12	F080222-001	Emergency Stop Cable/1000mm	1
1-27	F270275-000	Adjustment plate, motor	1	2-22-13	F300341-000	Hand pulse upper cover	2
1-28	F300043-002	Transistor washer	4	2-22-14	F300281-000	Hand pulse lower cover	2
1-29	F372046-001	Inverter	1	2-22-15	H020109-014	Screw M3x20L, Hand pulse lower cover	4
1-30	H020803-000	Bolt M4x10L, Inverter / End cap set	6	2-22-16	F270271-000	Hand pulse plate	4
1-31	F300347-000	Packing	8	2-22-17	F914015-001	Form	2
1-32	H020600-035	Bolt M6x15L, packing	8	2-22-18	F914030-000	Form	2
1-33	H021101-047	Washer, packing	12	2-22-19	F080221-000	Hand Pulse Transfer, 700mm	2
1-34	F330059-000	Rubber cushion 27L	6	2-22-20	F303033-001	Electronic spring	1
1-35	F300303-000	Adjustable pad	2	2-22-21	H021107-001	Washer / ϕ5.2xϕ10x0.8t mm	4
1-36	F500228-001	End cap set plate, left	1	2-23	F373405-000	Heart Rate PCB	1
1-37	F500229-001	End cap set plate, right	1	2-24	F080221-001	Transfer Cable, 100mm	1
1-38	F298012-001	Front roller	1	2-25	F080221-002	Transfer Cable, 410mm	1
1-39	H020626-005	Bolt M8x35L, front roller	2	2-26	F916435-023	Lower Overlay /K90	1
1-40	H021209-000	S Washer, front roller	4	2-27	F340063-001	Membrane	1
1-41	F299013-001	Rear roller	1	2-28	F916405-002	Stickers(Left) /K90	1
1-42	H020608-001	Bolt M8x70L , rear roller	2	2-29	F916405-001	Stickers(Right) /K90	1
1-43	F300314-102	Left roller cover /K90	1	2-30	F080188-000	Upper console wire (7P)	1
1-44	F300315-102	Right roller cover /K90	1	2-31	F080174-000	Quick Shift Cable	2
1-45	F580027-000	Running deck	1	2-32	F916406-010	Sticker /K90	1
1-46	H020802-002	Bolt M8x30L, running deck	2	2-33	F379000-000	Clip	1
1-47	F570060-001	Running belt	1	2-34	H020603-004	Bolt M8x15L	2
1-48	F083104-004	Power cord	1	2-35	F270777-000	Display Support	1
1-49	H020830-000	Bolt M8x40L, running deck	2	2-36	H020841-000	Bolt M3x8L	5
1-50	F270674-000	Tooth plate	2	2-37	F373424-000	Csafe PCB	1
1-51	H020638-001	Bolt M8x20L	6	2-38	F083132-000	Csafe power	1
1-52	F330031-001	Rubber cushion 15L	2	2-39	F300646-100	Csafe cover	1
1-53	F080189-000	Lower console wire (7P)	1	2-40	F346007-000	Cooper Tube	1
1-54	H022302-000	Nut M8x6.8t	6	2-41	F916346-013	Logo	1
1-55	H021109-039	Washerϕ10.1xϕ25.2x1.5t mm	2				
1-56	H021605-001	S Washer, wire set plate	2				
1-57	H021130-005	Washerϕ13.1xϕ26.1x2t mm	4				
1-58	H020302-030	Bolt M10x45mm	1				
1-59	H022102-004	Nut M10	2				

1-60	H022800-001	Tooth plate	2			
1-61	F916273-151	Right side rail sticker	1			
1-62	F916273-152	Left side rail sticker	1			
1-63	F377007-001	Wave filter	1			
1-64	H020803-000	Bolt M4x0.7-10Lmm	2			
1-65	F916215-001	Non-slip sticker	2			
1-66	H021120-004	M10 washer, Rubber cushion 27L	6			
1-67	H021101-002	M6 washer, Roller cover	4			

## PART LIST

ITEM	Part No.	DESCRIPTION	Q'TY	ITEM	Part No.	DESCRIPTION	Q'TY
3-1	F900393-000	Right handlebar	1	<b>QUICK SHIFT</b>			
3-2	F900392-000	Left handlebar	1	4-1	F880335-000	QUICK SHIFT	1
3-3	H020602-004	Bolt M8x25L	22	4-1-1	F240006-000	Quick shift cover	2
3-4	H021120-004	M8 washer	22	4-1-2	H020100-000	Screw M3x6L	12
3-5	F300306-102	Right console mast cover	1	4-1-3	F240008-001	Quick shift base cover (right)	1
3-6	F300305-102	Left console mast cover	1	4-1-4	H021111-000	M3 washer	4
3-7	H020822-002	Screw M5x15L	6	4-1-5	H020100-001	Screw M3x6L	4
3-8	F330039-000	Packing	2	4-1-6	F240007-000	Quick shift pushing base	2
3-9	F900394-007	Console mast set	1 set	4-1-7	H020801-002	Screw M5x12L	8
3-10	F300304-102	Upper motor cover	1	4-1-8	F373256-000	Quick shift board	2
3-11	F300418-000	Right adjustable pad cover	1	4-1-9	F290080-000	Pin	2
3-12	F300417-000	Left adjustable pad cover	1	4-1-10	F270428-000	Quick button fixing bracket	2
3-13	H020801-002	Bolt M5x12L	6	4-1-11	H021605-001	S washer M5	8
3-14	H021209-000	M8 S washer	22	4-1-12	F270658-000	Quick button fixing bracket (left)	1
3-15	F300282-002	End cap	4	4-1-13	F270657-000	Quick button fixing bracket (right)	1
3-16	F916212-032	Logo	1	4-1-14	F240005-001	Quick shift base cover (left)	1
3-17	H022800-001	Tooth plate	4	4-1-15	H028300-000	Hex Screw	8
3-18	F916438-000	Green Series Logo	2	4-1-16	F330054-000	Pad / φ5.9-1.9t	4
3-19	F270222-000	Power cord locker	1	4-1-17	H022311-000	Nut / M3x0.5x4t	2
3-20	H020201-003	Bolt M3x12L	1	4-1-18	H029108-000	Spring	4
				4-1-19	F916295-002	Pad	4
				4-1-20	F916295-003	Pad 34x20x5t	2
				<b>Fan</b>			
				5-1	F900485-000	Fan	1
				5-2	H020173-000	Bolt M4x12L, Fan	4
				<b>USB</b>			
				6-1	F373409-000	USB Port	1
				6-2	H020201-002	Bolt M3x6mm	6
				6-3	F080231-001	USB board cable	1
				6-4	F373415-000	UART USB Port	1
				6-5	H020212-000	Bolt M2x8mm	2
				6-6	F080231-001	Transfer Cable	1

# EXPLODED DRAWING

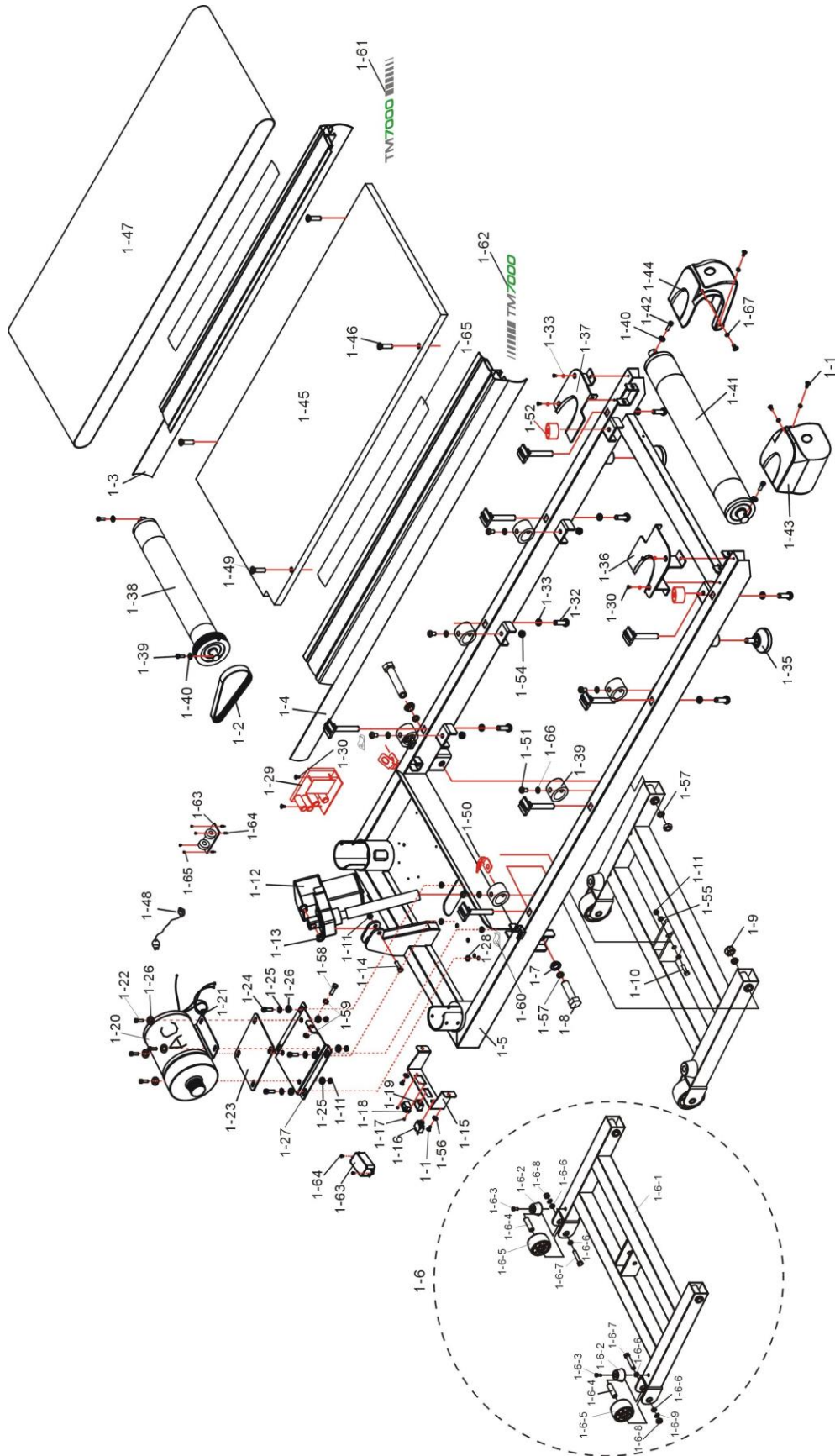

## EXPLODED DRAWING (CONSOLE SET)

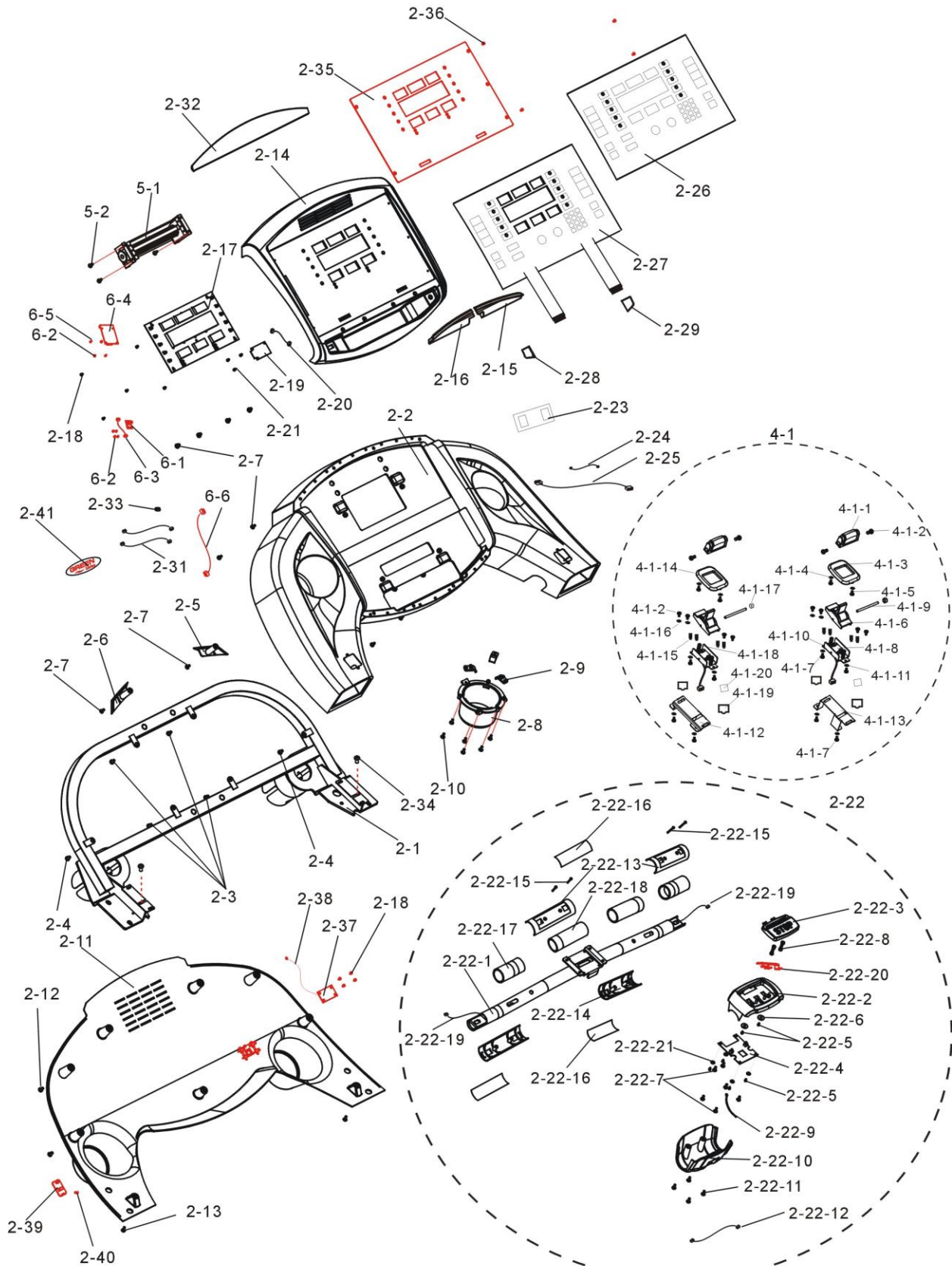

## EXPLODED DRAWING (CONSOLE MAST SET)



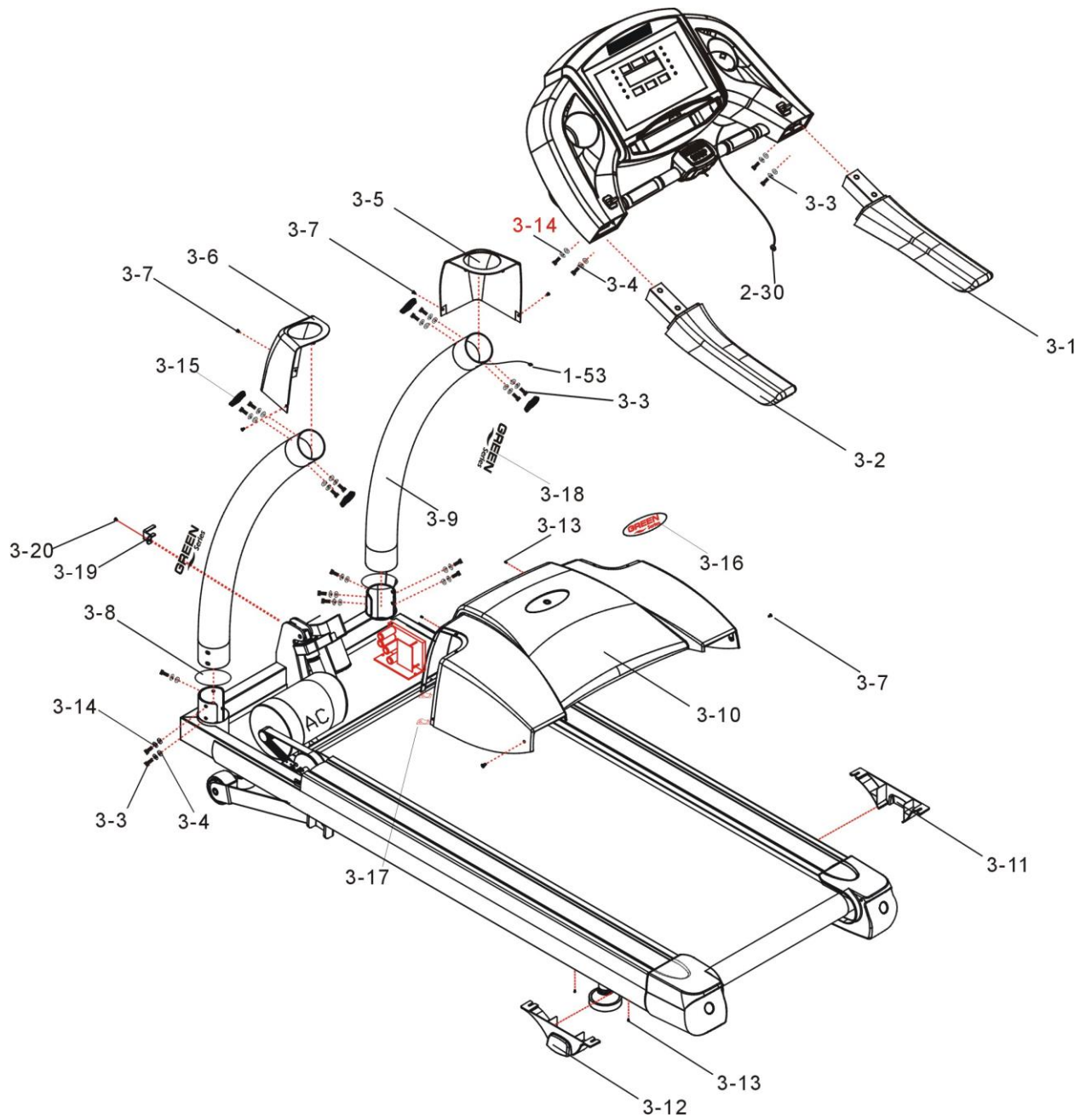



## Limited Warranty

### 6000 SERIES LIGHT COMMERCIAL WARRANTY

The Green Series™ 6000 light commercial warranty is intended for non-dues-paying facilities where equipment use is generally up to eight (8) hours per day.

### 7000 SERIES FULL COMMERCIAL WARRANTY

The Green Series™ 7000 full commercial warranty is intended for facilities where equipment use is regularly in excess of eight (8) hours per day. All dues-paying facilities fall into the category of a full commercial warranty as well as many non-dues-paying facilities.

Please note that any warranty services or questions must be accompanied by the model number and serial number from the transaction through which the warranted product was purchased. **The serial number serves as your warranty number and must be retained.** GREEN SERIES™ cannot provide warranty service without this number.

**GREEN SERIES™ Cardio Machines** warrant this product and its parts against defects in materials or workmanship for **ten (10) years frame, five (5) years motor, three (3) years parts, two (2) years wearables and one (1) year labor** from the initial install date. During this period, GREEN SERIES™ will repair or replace defective parts or equipment with new or reconditioned parts at GREEN SERIES™ option, without charge to customer. This limited warranty extends only to the original purchaser and is non-transferable. *(Excluding Indoor Cycling Bikes)*

**GREEN SERIES™ Indoor Cycling Bikes** warrant this product and its parts against defects in materials or workmanship for **five (5) years frame, two (2) years parts, one (1) year wearable and no labor** from the initial install date. During this period, GREEN SERIES™ will repair or replace defective parts or equipment with new or reconditioned parts at GREEN SERIES™ option, without charge to customer. This limited warranty extends only to the original purchaser and is non-transferable.

Shipping fees incurred from returns for under-warranty service in the warranty time-line will be paid by GREEN SERIES™. All shipping fees both to and from GREEN SERIES™ following this warranty time-line period must be paid by the customer. All returns, both during and following the warranty time-line period, must be affected via the Procedures for Obtaining Warranty Service described below.

All original parts (parts installed by GREEN SERIES™ at the original system build) replaced by GREEN SERIES™, its authorized service center or authorized service technician, become the property of GREEN SERIES™. Any after-market additions or modifications void all warranties. The original purchaser is responsible for the payment, at current rates, for any service or repair outside the scope of this limited warranty.

GREEN SERIES™ makes no other warranty, expressed or implied, including but not limited to implied warranties of merchantability, fitness for a particular purpose, or conformity to any representation or description, with respect to this warranty other than as set forth below. GREEN SERIES™ makes no warranty or representation, either expressed or implied, with respect to any other manufacturer's product or documentation, its quality, performance, merchantability, fitness for a particular purpose, or conformity to any representation or description.

Except as provided below, GREEN SERIES™ is not liable for any loss, cost, expense, inconvenience or damage that may result from use or inability to use the equipment. Under no circumstances shall GREEN SERIES™ be liable for any loss, cost, expense, inconvenience or damage exceeding the purchase price of the equipment.

The warranty and remedies set forth below are exclusive and in lieu of all others, oral or written, expressed or implied. No reseller, agent or employee is authorized to make any modification, extension or addition to this warranty.

### Warranty Conditions and Restrictions

The above Limited Warranty is subject to the following conditions:

[www.GreenSeriesFitness.com](http://www.GreenSeriesFitness.com)

©April 2017  
CIR-TM7000-G1 Revision 1.1

Call Toll free at 800-269-7130

1. This warranty extends only to products distributed and/or sold by **GREEN SERIES™**. It is effective only if the products are purchased and operated in the USA, (Within the USA including US 48 States, Alaska and Hawaii), Puerto Rico, Canada and Mexico. All countries outside the USA for warranty service do not include labor rates.
2. This warranty covers only normal use of the equipment. **GREEN SERIES™** shall not be liable under this warranty if any damage or defect results from (i) misuse, abuse, neglect, improper shipping or installation; (ii) disasters such as fire, flood, lightning or improper electric current; or (iii) service or alteration by anyone other than an authorized **GREEN SERIES™** representative; (iv) damages incurred through irresponsible use, including those resulting from equipment placed into humid environments, unfinished structures, structures under construction or remodel or placed in an outdoors setting, or other non-recommended practices.
3. **GREEN SERIES™** shall not be held liable or responsible for any damages to the units caused during the install of any product.
4. **GREEN SERIES™** shall not be held liable or responsible for any structural or cosmetic damages to facilities caused by the placement or operation of any equipment sold and installed by a **GREEN SERIES™** authorized service technician or installer.
5. Changes in the cosmetic appearance of components and parts within the unit that do not affect its performance will not be covered by any part of this warranty.
6. Damage due to normal wear and tear as defined by items subject to normal use and/or exposure, consumables, and cosmetic items, including, but not limited to the following: grips, seats, paint scratches, and labels.
7. Travel costs associated with service more than 100 miles or two hours outside the service area of **GREEN SERIES™** service technicians shall be the responsibility of the customer.
8. Any and all shipping damages, visible or hidden, shall be the responsibility of the shipper. Note: Damage caused by common carrier is, by federal law, the carrier's responsibility and must be claimed with the carrier at the time of delivery. The recipient who signed for the equipment is responsible for the filling of the damage claim and notification to **GREEN SERIES™**.
9. The end user of the equipment shall ensure that the facility has proper height, width and length clearances, including ADA requirements, for the product(s) being placed into operation. **GREEN SERIES™** will not be held liable or responsible for the fitment of equipment sold to the customer.
10. Customer must retain bill of sale or other proof of purchase and register equipment within thirty (30) days of installation to receive warranty service. Registration of the equipment ensures **GREEN SERIES™** the ability to provide prompt and complete service.
11. No warranty extension will be granted for any replacement part(s) furnished to the purchaser in fulfillment of this warranty.
12. **GREEN SERIES™** and its Authorized Service Center, dealers or authorized technicians accept no responsibility for any parts of any products returned for repair to **GREEN SERIES™**.
13. **GREEN SERIES™** makes no warranty either expressed or implied regarding third-party (**non-GREEN SERIES™**) installed parts, accessories or modifications.
14. All **GREEN SERIES™** equipment shall be properly cleaned and cared for in accordance to the procedures outlined the in the owner's manual.

#### **Return of Non-Defective Products**

A non-defective product may be returned to **GREEN SERIES™** within thirty (30) days of the invoice or installation date for a refund of the original purchase price, not including shipping fees, under the following conditions/fees:

[www.GreenSeriesFitness.com](http://www.GreenSeriesFitness.com)

©April 2017  
CIR-TM7000-G1 Revision 1.1

Call Toll free at 800-269-7130

1. **GREEN SERIES™** will refund the cost of equipment only. Customer is responsible for shipping and handling fees incurred to and from the product(s) return.
2. No refund will be granted for equipment which has been opened, used, or tampered with in any way which jeopardizes **GREEN SERIES™** ability to remarket or resell the product. **GREEN SERIES™** maintains full discretion in decisions regarding product returns.
3. Any non-defective returns are subject to a twenty-five percent (25%) restocking fee. This fee will be deducted from the equipment purchase price refund less any shipping or handling charges.

To return a defective product, please contact the selling dealer or Green Series Customer Service Department for a Return Merchandise Authorization (RMA) number and follow the Return of Products Instructions below. The RMA is valid for thirty (30) days from date of issuance. **Returns will not be accepted without an RMA.** Manufacturer restrictions do apply. Any item missing the UPC on the original packaging may not be returned.

#### **Procedures for Obtaining Warranty Service**

RMA (Return Merchandise Authorization) Policy:

The customer must obtain an RMA number and provide proof of purchase. RMA and services are rendered by **GREEN SERIES™** only. Any shipping costs after the for-mentioned warranty lengths (starting from the original date of install) on any item returned for repair or replacement is the customers' responsibility. All returned parts and equipment must have an RMA number written clearly on the outside of the package along with a letter detailing the problems and a copy of the original proof of purchase. No COD packages will be accepted. No package will be accepted without a RMA number written on the outside of the package. RMA numbers are only valid for thirty (30) days from the date of issue.

Should you have any problems with your equipment, please follow these procedures to obtain the service:

1. If the equipment must be repaired, contact our Customer Care Department and a **Service Order Number** will be issued by Customer Care for dispatch of an authorized technician.
2. Upon receiving the technician service report, **GREEN SERIES™** will repair or replace your defective parts and will ship replacement parts to the location specified (dependent on parts availability) via UPS.
3. **GREEN SERIES™** will pay for shipping to and from the customer only within the time allocated under the warranty time-line following the original product installation date. Following this period all shipping fees for post warranty repairs are the sole responsibility of the customer. The customer also assumes full liability for losses or damages resulting from shipping as well as all responsibility to pursue remuneration for such issues with their selected carrier.

#### **After Warranty – Post Warranty Repair**

For post warranty repair, the procedure is the same as outlined above for service and shipping. However, customer is responsible for shipping charges both ways, labor, trip charges and the current price of part(s) needed to repair the product(s).

#### **WARRANTY EXCLUSIONS**

**GREEN SERIES™** does not offer technical support for any product or parts installed by other manufacturers. Technical support should be pursued through channels offered by the equipment's individual technician support. **GREEN SERIES™** accepts no liability for problems caused by after-market hardware modifications or additions. **GREEN SERIES™** is not responsible for giving any technical support concerning the installation or integration of any component the customer did not pay **GREEN SERIES™** to install. **GREEN SERIES™** is not responsible for loss of time, even with hardware failure. **GREEN SERIES™** is not responsible for any loss of work ("down time") caused by a product requiring service. This warranty is null and void if the defect or malfunction was due to damage resulting from operation not within manufacturer specifications. It will also be null and void if there are indications of misuse and/or abuse. **GREEN SERIES™** has the option of voiding the warranty if anyone other than a **GREEN SERIES™** authorized technician attempts to service the product. **GREEN SERIES™** will not warrant any problems arising from an act of God (lighting, flooding, tornado, etc.), electrical spikes or surges, or problems arising out of hardware or additional devices added to complement any system/component bought at **GREEN SERIES™**. Under no circumstances will **GREEN SERIES™** be responsible for any refund or remuneration exceeding the original purchase price of the product less any shipping fees. **GREEN SERIES™** will not be held responsible for typographical errors on sales receipts, repair tickets, or on our websites. **GREEN SERIES™** makes every effort to ensure all information on our websites, owner's manuals, marketing and other published materials is accurate.

- **By using this product, I indicate that I understand and agree to the terms of this warranty.**

