

Owner's Manual



VOR-IC7000-G

Full Commercial Indoor Cycle

Install Date: _____ Serial Number: _____

www.GreenSeriesFitness.com

©June 2015
VOR-IC7000-G Revision 1.1

Call Toll free at (800) 269-7410

TABLE OF CONTENTS

SAFETY PRECAUTIONS	2-3
Important information, how often you exercise, how hard you exercise, how long you exercise, target heart rate zone.	
TECHNICAL SPECIFICATIONS	4
UNPACKING	5
Parts, hardware kit	
ASSEMBLY	6-7
EXPLODED DRAWING	8
PARTS LIST	9
INSTRUCTIONS FOR USE	10
WARRANTY	11-14

IMPORTANT SAFETY INSTRUCTIONS

SAVE THESE INSTRUCTIONS

READ ALL INSTRUCTIONS BEFORE USING THIS EXERCISE EQUIPMENT.

- * Keep children off your bike at all times.
- * When the bike is in use, young children and pets should be kept at least 10 feet away.
- * Use this bike only for its intended use as described in the manual.
- * Keep your hands away from all moving parts; Never turn the pedal crank arms by hand.
- * Do not remove your feet from the pedals while the pedals are in motion.
- * After exercising, push down on the tension knob or turn the tension knob in a clockwise direction to slow the flywheel down to decrease the potential for injury.
- * Do not dismount the bike until both the pedals and flywheel have come to a complete stop.
- * Do not attempt to use this bike at high speeds or in standing positions until you have practiced and are comfortable at lower speeds.
- * Rotate the tension knob clockwise to add resistance to the flywheel prior to standing on the pedals.
- * Never drop or insert any object into any opening on this bike.
- ** Do not use without proper footwear.

To ensure that the safety level of this bike is maintained, examine components for wear and tear on a regular basis. Components that are worn excessively or inoperable should be replaced immediately or the bike should be put out of service until the unit is repaired.

Caution:

If you experience chest pains, nausea, dizziness or shortness of breath, stop exercising immediately and consult your physician before continuing.

SAFETY PRECAUTIONS

CONSULT A PHYSICIAN IMMEDIATELY

Warning: before starting any exercise program consult your physician. This is especially important for individuals over the age of 35 or persons with preexisting health problems. Read all instructions before using any fitness equipment. We assume no responsibility for personal injury damage sustained by or through the use of this treadmill.

How often you exercise:

You should exercise three to four times a week to improve your cardiovascular and muscle fitness.

How hard you exercise:

Intensity of exercise is reflected in your heart rate. Exercise must be sufficiently rigorous to strengthen your heart muscle and condition your cardiovascular system.

Only your doctor can prescribe the target training heart range for you. Before starting any exercise program consult your physician.

How long you exercise:

Sustained exercise conditions your heart, lungs and muscles. The longer you are able to sustain exercise within your target heart range, the greater the aerobic benefits. To begin maintain 2~3 minutes of steady, rhythmic exercise, then check your heart rate.

BEGINNER TREADMILL PROGRAM

	EXERTION LEVEL	DURATION
WEEK 1	Easy	6~12 minutes
WEEK 2	Easy	10~16 minutes
WEEK 3	Moderate	14~20 minutes
WEEK 4	Moderate	18~24 minutes
WEEK 5	Moderate	22~28 minutes
WEEK 6	Slightly higher or slightly lower	20 minutes
WEEK 7	Add interval training	3 minutes at moderate exertion with 3 minutes at higher exertion for 24 minutes

TARGET HEART RATE ZONE

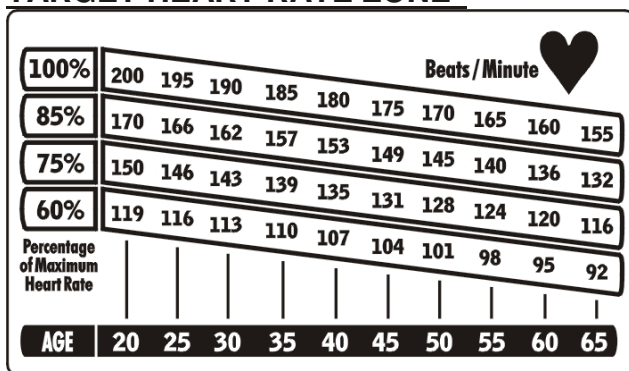

100% Increased Performance Range

85% Aerobic Training Range

75% Weight Loss Training Range

60% Heart Rate BPM

220-your age = maximum heart zone

You do not want to workout at your maximum heart rate. The recommended Heart Rate Zone is a percentage of your maximum heart rate. Between 65% and 85% of your maximum heart rate.

* Lower limit of Target Heart Rate Zone = maximum heart rate X 0.6

* Upper limit of Target Heart Rate Zone = Maximum heart rate X 0.75

(This is recommended by American Heart Association. Before starting exercise program, please consult your physician to understand your physical situation)

TECHNICAL SPECIFICATIONS

VOR-IC7000-G

Length: 43" (109 cm)

Width: 24" (61cm)

Height: 47" (119cm)

Weight of product: 121 lbs. (55 kg)

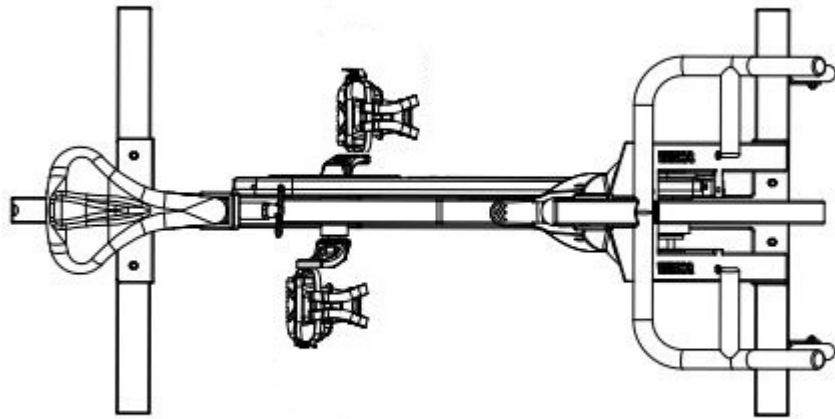

UNPACKING VOR-IC7000-G

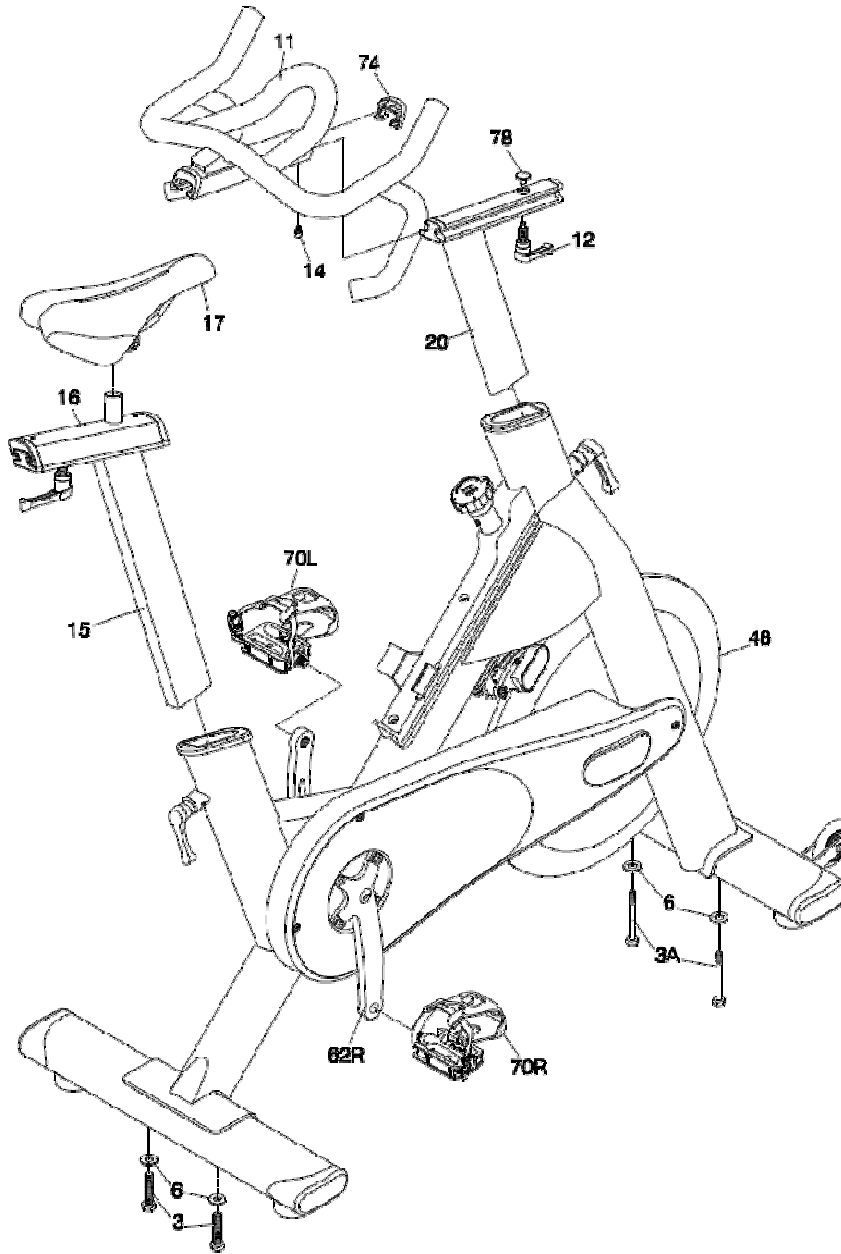

ASSEMBLY

VOR-IC7000-G

Step 1: Front Foot

Attach the front foot (#7) to the frame using the (2) bolts (#3A) and (2) washers (#6) as illustrated in the diagram and then tighten the bolts.

Step 2: Rear Foot

Attach the rear foot (#2) to the frame using the (2) bolts (#3A) and (2) washers (#6) as illustrated in the diagram and then tighten the bolts.

STEP 1

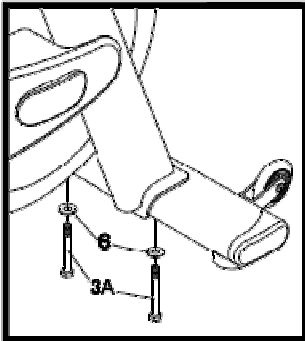

STEP 2

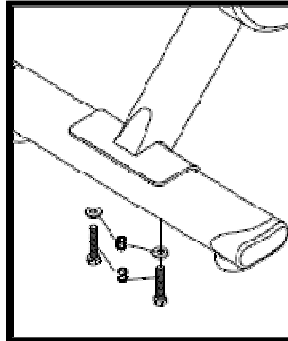

Step 3: Pedals

1. Attach the pedals (#70R/#70L) into the crank arms (#62R/#62L). Each pedal is marked with the letter R (right) or L (left) to denote the side of the bike they are located.

NOTE: the right hand crank is on the same side as the chain cover (#71).

2. Be careful to align the threads correctly to avoid any damage. Apply Loctite Threadlocker Blue-242 on the thread and tighten using a 15mm wrench.

- Pedal marked R installed on right crank (clockwise),
- Pedal marked L installed on left crank (counterclockwise).
- Pedals must be fastened with significant force to avoid loosening while using the indoor cycle. (25-30 lbs. ft. torque)

STEP 3

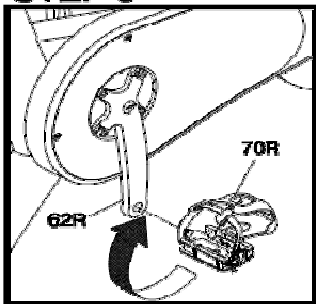

Example of pedal installation

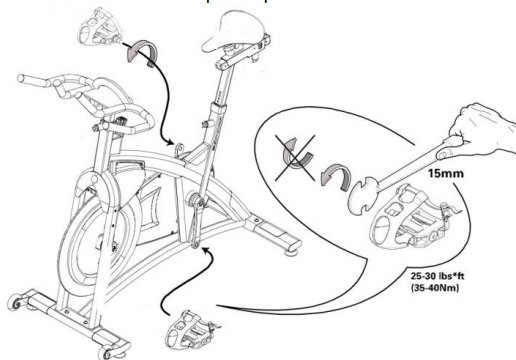

Step 4-5: Handlebar & Stem

1. Insert Stem (#20) into main frame of the bike.
2. Use lock lever (#18) to tighten.
3. Insert (1) Stem/Post Slider locking tab onto the top of the Stem (#20).
4. Attach (1) (#74) Handlebar (front) End Cap and (1) (#75) Handlebar (rear) End Cap to Handlebar Frame (#11). Ensure that the endcaps are fully seated into the handlebar frame.
5. Attach Handlebar (#11) onto Handlebar Slider (#13) using (4) bolts (#5) and (1) Handlebar and Slider fix Plate (#4).
6. Attach the Lock Lever (#12) onto the Handlebar Slider (#13). Slide the Handlebar assembly until you reach the desired position.
7. Use Lock Lever (#12) to tighten and secure the selected position.
8. Place the Handlebar-stem assembly into the front tube and adjust to your ideal position.
9. Using Lock Lever (#18), tighten and secure to desired position.

NOTE: Do not rise above the safety line.

STEP 4

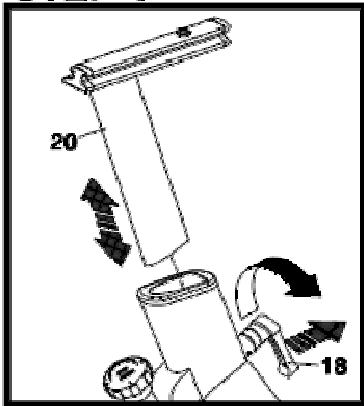

STEP 5

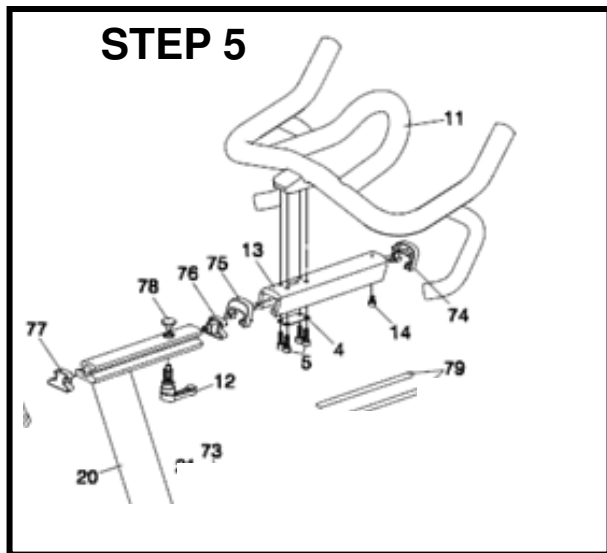

Step 6-7: Saddle & Seat Post

1. Insert seat post (#15) into frame's seat tube, assembly saddle (#17) on saddle top slider (#16).
2. Adjust slider using lock lever (#12) for forwards or backwards, and then tighten until reach the proper position. Using lock lever (#18) adjusts seat post (#15) and tighten to secure proper position.

STEP 6

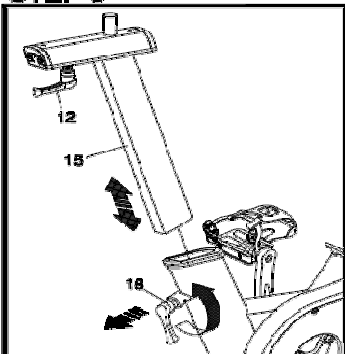

STEP 7

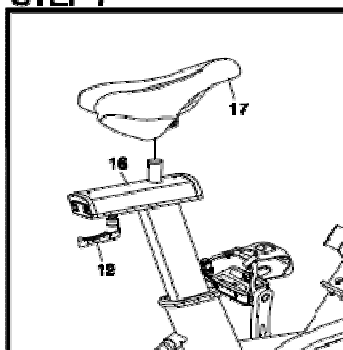

NOTE: Do not rise above the safety line.

Exploded Diagram VOR-IC7000-G

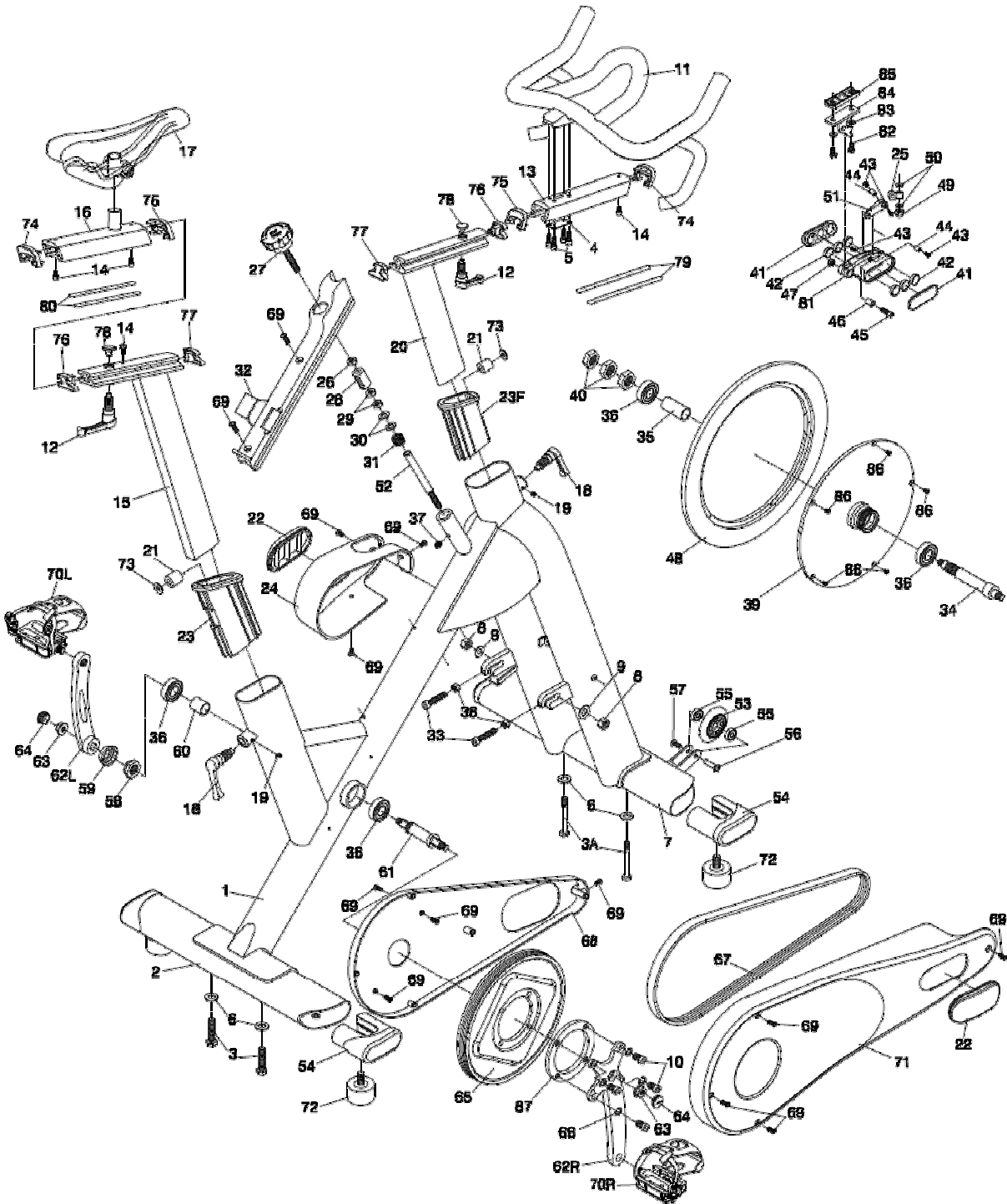

Parts List

VOR-IC7000-G

part no.	description	q'ty	part no.	description	q'ty
1	Main Frame	1	45	Bolt	1
2	Rear Ground Tube	1	46	Sleeve	1
3	Rear Ground Tube Fixed Bolts	2	47	Nut	1
3A	Front Ground Tube fixed bolts	2	48	Washer	1
4	Handlebar & Slider fix plate	1	49	Cap Nut	1
5	bolts	4	50	Spring Washer	1
6	Washer	4	51	Brake Set Adjuster	1
7	Front Ground Tube	1	52	Stud	1
8	Fly Wheels Fixed Nut	2	53	PU Moving Wheel	2
9	Washer	2	54	Grounds End Cap	4
10	bolts	4	55	Bearing 608ZZ	4
11	Handle Bar	1	56	Nut	2
12	Lock lever for HB and seat slider	2	57	Bolt	2
13	Handlebar Slider	1	58	Axle Lock Nut	1
14	Slider's safety stoper	4	59	Dusty Cover	1
15	Seat Post	1	60	Spacer	1
16	Saddle slider	1	61	B.B Axle	1
17	Saddle	1	62L	Left Crank	1
18	Lock Lever For Stem & Post	2	62R	Right Crank	1
19	Set Screw	2	63	Flange Nut	2
20	Stem	1	64	Plastic cap	2
21	Locking Piece	2	65	Driving Pulley	1
22	Pop cover	2	66	washer	4
23F/23	Plastic Sleeve for H/T and S/T	2	67	Belt	1
24	Left Cover	1	68	Inner Cover	1
25	Nut	1	69	Screw	13
26	Nut	1	70 R/L	LU-214 alloy body w/ toe clip& strap.	1
27	Adjust Knob	1	71	Outer Chain Cover	1
28	Floating Piece	1	72	Ground Tube's Adjusting Pad	4
29	Nut	2	73	Washer	2
30	Washer	2	74	HB(F) & Saddle Slider's (R) End Cap	2
31	Spring	1	75	HB(R) & Saddle Slider's (F) End Cap	2
32	Integrated Plastic Bottle Cage	1	76	Stem(F) & Post Slider's (R) End Cap	2
33	Axles Adjusting Bolts	2	77	Stem(R) & Post Slider's (F) End Cap	2
34	Fly Wheels Axle	1	78	Stem/Post Slider's Locking	2
35	Spacer	1	79	Stem Top Slider's Protector	2
36	B.B & Fly Wheel Axle's Bearing	4	80	Saddle Slider's Protector	2
37	Floating piece set screw	1	81	Magnetic Set	1
38	Fly Wheel's Alloy ring	1	82	Screw	2
39	Casting Fly Wheel	1	83	Washer	2
40	Lock Nut	3	84	Magnetic set's Mounting bass	1
41	Magnetic set's side cover	2	85	Adapter	1
42	Magnetic set's side cover	6	86	Screw	5
43	screw Set	1	87	Gusset Ring	1
44	Sleeve	1			

INSTRUCTIONS FOR USE

VOR-IC7000-G

- 1) The VOR-IC7000-G is designed to be used as an "indoor cycling" cycle in fitness studios and health clubs. It has a fixed wheel driven flywheel and should only be used under professional supervision.
- 2) Installation - It is important that the VOR-IC7000-G is correctly assembled and we recommend that installation and assembly be carried out by suitably qualified personnel.
- 3) Handlebar and seat adjustment. It is important that the handlebar and seat are set at the correct height for your body. Ask your instructor for assistance.

Adjusting the handlebar stem and seat post height - Make sure it is securely tightened and that there is no lateral or vertical movement of the handlebar stem and seat post. Undo the quick release lever which is locked in front of head tube. Slide the handlebar stem up or down to the required height and then retighten.

The handlebar/stem position can also be adjusted forwards or backwards. Undo the Quick Release lever located below the slider. Slide the handlebar/stem assembly forwards or backwards until you reach the right position. Then securely re-tighten the Quick Release lever.
Adjusting the seat height - refer to above mention.

NOTE: There is a safety line engraved on the handlebar stem and seat post. Under no operating condition should the handlebar stem and seat post ever be raised above this line.

- 4) Pedals and toe straps - Your feet should be securely positioned in the toe clips during the exercise. Place your foot as far forward as you can into the toe-clip and then pull the strap tight.
- 5) Resistance system - VOR-IC7000-G bike is equipped with a durable belt, direct drive transmission system. To adjust the exercising resistance on the completed indoor cycle, please refer to knob assembly.
- 6) The VOR-IC7000-G should be operated on a level surface with no lateral movement. There is height adjuster caps located on either side underneath the rear foot. Turn these caps clockwise or counter-clockwise until the bike is totally stable on the ground.
- 7) Maintenance - Like any other mechanical cycling device, the VOR-IC7000-G should be regularly maintained.

Ask your dealer for a detailed maintenance program.



Limited Warranty

6000 SERIES LIGHT COMMERCIAL WARRANTY

The Green Series™ 6000 light commercial warranty is intended for non-dues-paying facilities where equipment use is generally up to eight (8) hours per day.

7000 SERIES FULL COMMERCIAL WARRANTY

The Green Series™ 7000 full commercial warranty is intended for facilities where equipment use is regularly in excess of eight (8) hours per day. All dues-paying facilities fall into the category of a full commercial warranty as well as many non-dues-paying facilities.

Please note that any warranty services or questions must be accompanied by the model number and serial number from the transaction through which the warranted product was purchased. **The serial number serves as your warranty number and must be retained.** GREEN SERIES™ cannot provide warranty service without this number.

GREEN SERIES™ Cardio Machines warrant this product and its parts against defects in materials or workmanship for **ten (10) years frame, five (5) years motor, three (3) years parts, two (2) years wearables and one (1) year labor** from the initial install date. During this period, GREEN SERIES™ will repair or replace defective parts or equipment with new or reconditioned parts at GREEN SERIES™ option, without charge to customer. This limited warranty extends only to the original purchaser and is non-transferable. (*Excluding Indoor Cycling Bikes*)

GREEN SERIES™ Indoor Cycling Bikes warrant this product and its parts against defects in materials or workmanship for **five (5) years frame, two (2) years parts, one (1) year wearable and no labor** from the initial install date. During this period, GREEN SERIES™ will repair or replace defective parts or equipment with new or reconditioned parts at GREEN SERIES™ option, without charge to customer. This limited warranty extends only to the original purchaser and is non-transferable

Shipping fees incurred from returns for under-warranty service in the warranty time-line will be paid by GREEN SERIES™. All shipping fees both to and from GREEN SERIES™ following this warranty time-line period must be paid by the customer. All returns, both during and following the warranty time-line period, must be affected via the Procedures for Obtaining Warranty Service described below.

All original parts (parts installed by GREEN SERIES™ at the original system build) replaced by GREEN SERIES™, its authorized service center or authorized service technician, become the property of GREEN SERIES™. Any after-market additions or modifications void all warranties. The original purchaser is responsible for the payment, at current rates, for any service or repair outside the scope of this limited warranty.

GREEN SERIES™ makes no other warranty, expressed or implied, including but not limited to implied warranties of merchantability, fitness for a particular purpose, or conformity to any representation or description, with respect to this warranty other than as set forth below. GREEN SERIES™ makes no warranty

or representation, either expressed or implied, with respect to any other manufacturer's product or documentation, its quality, performance, merchantability, fitness for a particular purpose, or conformity to any representation or description.

Except as provided below, **GREEN SERIES™** is not liable for any loss, cost, expense, inconvenience or damage that may result from use or inability to use the equipment. Under no circumstances shall **GREEN SERIES™** be liable for any loss, cost, expense, inconvenience or damage exceeding the purchase price of the equipment.

The warranty and remedies set forth below are exclusive and in lieu of all others, oral or written, expressed or implied. No reseller, agent or employee is authorized to make any modification, extension or addition to this warranty.

Warranty Conditions and Restrictions

The above Limited Warranty is subject to the following conditions:

1. This warranty extends only to products distributed and/or sold by **GREEN SERIES™**. It is effective only if the products are purchased and operated in the USA, (Within the USA including US 48 States, Alaska and Hawaii), Puerto Rico, Canada and Mexico. All countries outside the USA for warranty service do not include labor rates.
2. This warranty covers only normal use of the equipment. **GREEN SERIES™** shall not be liable under this warranty if any damage or defect results from (i) misuse, abuse, neglect, improper shipping or installation; (ii) disasters such as fire, flood, lightning or improper electric current; or (iii) service or alteration by anyone other than an authorized **GREEN SERIES™** representative; (iv) damages incurred through irresponsible use, including those resulting from equipment placed into humid environments, unfinished structures, structures under construction or remodel or placed in an outdoors setting, or other non-recommended practices.
3. **GREEN SERIES™** shall not be held liable or responsible for any damages to the units caused during the install of any product.
4. **GREEN SERIES™** shall not be held liable or responsible for any structural or cosmetic damages to facilities caused by the placement or operation of any equipment sold and installed by a **GREEN SERIES™** authorized service technician or installer.
5. Changes in the cosmetic appearance of components and parts within the unit that do not affect its performance will not be covered by any part of this warranty.
6. Damage due to normal wear and tear as defined by items subject to normal use and/or exposure, consumables, and cosmetic items, including, but not limited to the following: grips, seats, paint scratches, and labels.
7. Travel costs associated with service more than 100 miles or two hours outside the service area of **GREEN SERIES™** service technicians shall be the responsibility of the customer.
8. Any and all shipping damages, visible or hidden, shall be the responsibility of the shipper. Note: Damage caused by common carrier is, by federal law, the carrier's responsibility and must be claimed with the carrier at the time of delivery. The recipient who signed for the equipment is responsible for the filing of the damage claim and notification to **GREEN SERIES™**.

9. The end user of the equipment shall ensure that the facility has proper height, width and length clearances, including ADA requirements, for the product(s) being placed into operation. **GREEN SERIES™** will not be held liable or responsible for the fitment of equipment sold to the customer.
10. Customer must retain bill of sale or other proof of purchase and register equipment within thirty (30) days of installation to receive warranty service. Registration of the equipment ensures **GREEN SERIES™** the ability to provide prompt and complete service.
11. No warranty extension will be granted for any replacement part(s) furnished to the purchaser in fulfillment of this warranty.
12. **GREEN SERIES™** and its Authorized Service Center, dealers or authorized technicians accept no responsibility for any parts of any products returned for repair to **GREEN SERIES™**.
13. **GREEN SERIES™** makes no warranty either expressed or implied regarding third-party (**non-GREEN SERIES™**) installed parts, accessories or modifications.
14. All **GREEN SERIES™** equipment shall be properly cleaned and cared for in accordance to the procedures outlined the in the owner's manual.

Return of Non-Defective Products

A non-defective product may be returned to **GREEN SERIES™** within thirty (30) days of the invoice or installation date for a refund of the original purchase price, not including shipping fees, under the following conditions/fees:

1. **GREEN SERIES™** will refund the cost of equipment only. Customer is responsible for shipping and handling fees incurred to and from the product(s) return.
2. No refund will be granted for equipment which has been opened, used, or tampered with in any way which jeopardizes **GREEN SERIES™** ability to remarket or resell the product. **GREEN SERIES™** maintains full discretion in decisions regarding product returns.
3. Any non-defective returns are subject to a twenty-five percent (25%) restocking fee. This fee will be deducted from the equipment purchase price refund less any shipping or handling charges.

To return a defective product, please contact the selling dealer or Green Series Customer Service Department for a Return Merchandise Authorization (RMA) number and follow the Return of Products Instructions below. The RMA is valid for thirty (30) days from date of issuance. **Returns will not be accepted without an RMA.** Manufacturer restrictions do apply. Any item missing the UPC on the original packaging may not be returned.

Procedures for Obtaining Warranty Service

RMA (Return Merchandise Authorization) Policy:

The customer must obtain an RMA number and provide proof of purchase. RMA and services are rendered by **GREEN SERIES™** only. Any shipping costs after the for-mentioned warranty lengths (starting from the original date of install) on any item returned for repair or replacement is the customers' responsibility. All returned parts and equipment must have an RMA number written clearly on the outside of the package along with a letter detailing the problems and a copy of the original proof of purchase. No COD packages will be

accepted. No package will be accepted without a RMA number written on the outside of the package. RMA numbers are only valid for thirty (30) days from the date of issue.

Should you have any problems with your equipment, please follow these procedures to obtain the service:

1. If the equipment must be repaired, contact our Customer Care Department and a **Service Order Number** will be issued by Customer Care for dispatch of an authorized technician.
2. Upon receiving the technician service report, **GREEN SERIES™** will repair or replace your defective parts and will ship replacement parts to the location specified (dependent on parts availability) via UPS.
3. **GREEN SERIES™** will pay for shipping to and from the customer only within the time allocated under the warranty time-line following the original product installation date. Following this period all shipping fees for post warranty repairs are the sole responsibility of the customer. The customer also assumes full liability for losses or damages resulting from shipping as well as all responsibility to pursue remuneration for such issues with their selected carrier.

After Warranty – Post Warranty Repair

For post warranty repair, the procedure is the same as outlined above for service and shipping. However, customer is responsible for shipping charges both ways, labor, trip charges and the current price of part(s) needed to repair the product(s).

WARRANTY EXCLUSIONS

GREEN SERIES™ does not offer technical support for any product or parts installed by other manufacturers. Technical support should be pursued through channels offered by the equipment's individual technician support. **GREEN SERIES™** accepts no liability for problems caused by after-market hardware modifications or additions. **GREEN SERIES™** is not responsible for giving any technical support concerning the installation or integration of any component the customer did not pay **GREEN SERIES™** to install. **GREEN SERIES™** is not responsible for loss of time, even with hardware failure. **GREEN SERIES™** is not responsible for any loss of work ("down time") caused by a product requiring service. This warranty is null and void if the defect or malfunction was due to damage resulting from operation not within manufacturer specifications. It will also be null and void if there are indications of misuse and/or abuse. **GREEN SERIES™** has the option of voiding the warranty if anyone other than a **GREEN SERIES™** authorized technician attempts to service the product. **GREEN SERIES™** will not warrant any problems arising from an act of God (lighting, flooding, tornado, etc.), electrical spikes or surges, or problems arising out of hardware or additional devices added to complement any system/component bought at **GREEN SERIES™**. Under no circumstances will **GREEN SERIES™** be responsible for any refund or remuneration exceeding the original purchase price of the product less any shipping fees. **GREEN SERIES™** will not be held responsible for typographical errors on sales receipts, repair tickets, or on our websites. **GREEN SERIES™** makes every effort to ensure all information on our websites, owner's manuals, marketing and other published materials is accurate.

➤ **By using this product, I indicate that I understand and agree to the terms of this warranty.**

