

Owner's Manual

GREEN Series™



CIR-RB6000-G1

Light Commercial Recumbent Bike



Install Date: _____

Serial Number: _____

TABLE OF CONTENTS

SAFETY PRECAUTIONS	2-3
Important voltage information, grounding instructions, how often you exercise, how hard you exercise, how long you exercise, beginner treadmill program, target heart rate zone.	
TECHNICAL SPECIFICATIONS	4
UNPACKING & ASSEMBLY	5-20
Parts, hardware kit and assembly drawing	
WARM UP & COOL DOWN	21
PANEL CONTROL & PROGRAM	22-29
Control panel function and programs	
EQUIPMENT ADJUSTMENTS	30
CARE & MAINTENANCE	31
PARTS LIST	32-33
EXPLODED DRAWINGS	34-35
WARRANTY	36-38

SAFETY PRECAUTIONS

Dear Customer,

Thank you for your purchasing our products. This product has been designed and manufactured for full commercial use, even though we go to great efforts to ensure the quality of each product, occasional error, and/or omissions do occur. In any event should you find this product to be defective or missing parts please contact us.

IMPORTANT: Read all instructions and warnings before assembly and operation.

- Only one person at a time should use this equipment. If dizziness, nausea, chest pains, or any other abnormal symptoms are experienced while using this elliptical, stop the workout at once.
- **Warning:** Incorrect/ excessive training can cause health injuries. Stop using the elliptical when feeling uncomfortable.
- Consult your physician before starting a workout or training program. Have your doctor review your training and diet programs to advise you of a workout routine you should adopt.
- Always use this equipment on a clear and level surface. Do not use outdoors or near water.
- Don't insert any object into any openings.
- Before using this equipment to exercise, always do stretching exercises to properly warm up.
- Replace defective components immediately and keep the equipment out of use until repair.
- This product is designed for adults. Please ensure that children only use it under the supervision of an adult.
- Make sure that all bolts and nuts are tightened when equipment is in use. Periodic maintenance is required on all exercise equipment to keep it in good condition.
- Close supervision is necessary when this appliance is used by, on, or near children, invalids, or disabled persons.
- Use this appliance only for its intended use as described in this manual. Do not use attachments, not recommended by the manufacture.
- Never operate the appliance with the air openings blocked. Keep the air openings free of lint, hair, and the like.
- Never drop or insert any object into any opening.
- Do not use outdoors.
- The appliance is intended for commercial use.
- Maximum user weight: 500lbs (227 kg).

SAFETY PRECAUTIONS

CONSULT A PHYSICIAN IMMEDIATELY

Warning: Before starting any exercise program consult your physician. This is especially important for individuals over the age of 35 or persons with preexisting health problems. Read all instructions before using any fitness equipment. We assume no responsibility for personal injury damage sustained by or through the use of this equipment.

How often you exercise:

You should exercise three to four times a week to improve your cardiovascular and muscle fitness.

How hard you exercise:

Intensity of exercise is reflected in your heart rate. Exercise must be sufficiently rigorous to strengthen your heart muscle and condition your cardiovascular system.

Only your doctor can prescribe the target training heart range for you. Before starting any exercise program consult your physician.

How long you exercise:

Sustained exercise conditions your heart, lungs and muscles. The longer you are able to sustain exercise within your target heart range, the greater the aerobic benefits. To begin maintain 2~3 minutes of steady, rhythmic exercise, then check your heart rate.

TECHNICAL SPECIFICATIONS

SPECIFICATIONS:

Length: 61" (155 cm)

Width: 24" (62.5cm)

Height: 52" (132cm)

Weight of product: 150.7lbs (68.5kg)

Program : Manual, 6 preset programs, Fitness Test · HRCx4

Standard features: 8x16 dot matrix HR receive

Resistance System : PMS(Perment Magnet System)

Power source : Built-in generator & rechargeable battery 12V-1.2AH

The Serial Number of the products

The serial number contains of ten values. The location of the serial number shows as the figure.

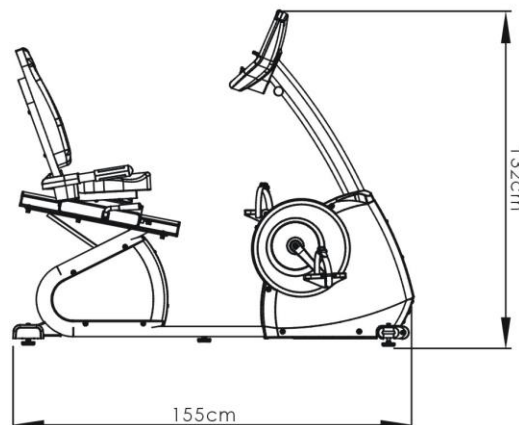
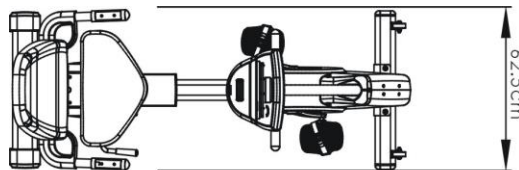

UNPACKING & ASSEMBLY

Parts (Main frame)

#1

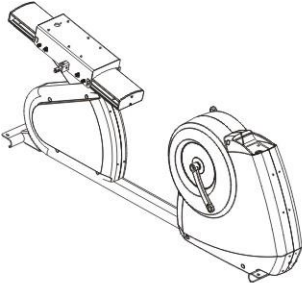

Main frame X 1pc

#4-1

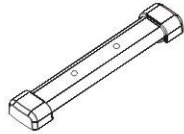

Rear stabilizer X 1pc

#4-2



Front stabilizer X 1pc

#4-32



Console set X 1pc

#4-7

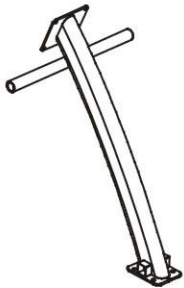

Handle bar post X 1pc

#4-8

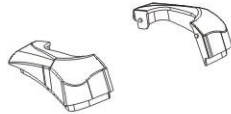

Front cover X 1 set

#4-9

#4-5

#4-6



Pedal set X 1set

UNPACKING & ASSEMBLY

Parts (seat set)

#4-13

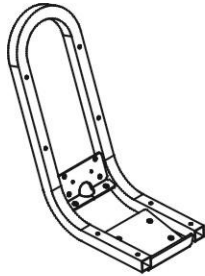

Backrest frame X
1pc

#4-19

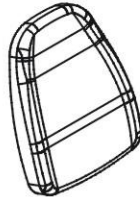

Seat, Backrest
X 1pc

#4-16

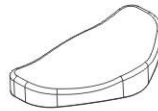

Seat X 1pc

#4-25



Backrest frame front
cover X 1pc

#4-26



Backrest frame rear
cover X 1pc

#4-28



#4-27



Left/ Right track cover
X 1pc

#4-20

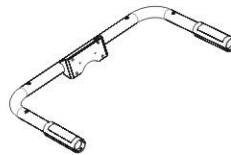

Lower hand pulse X
1pc





#4-22











Water bottle holder
X 1set

UNPACKING & ASSEMBLY

Hardware kit

Step 7	 M6x40mm #4-17 X 4 (seat/ backrest)	 M6 S washer #4-18 X 4 (seat/ backrest)
Step 8	 M6x45mm #4-18 X 4 (seat/ backrest)	 M6x45mm #4-18 X 4 (seat/ backrest)
Step 9	 M4x12mm #4-24 X 4 (water bottle holder)	

- 
#1-7
X 1
(adjust pad)
- 
#4-29
#4-30
X 1
(Adjust lever, seat)
- 
M15/M15
X 1
- 
Allen wrench
(8mm)
X 1
- 
Allen wrench
(6mm)
X 1
- 
Allen wrench
(5mm)
X 1
- 
Allen wrench
(4mm)
X 1
- 
Allen wrench
(3mm)
X 1

UNPACKING & ASSEMBLY

Unpack your recumbent bike where will be using it. Be careful not to damage individual pieces. Place your recumbent bike on a level flat surface. It is recommended that you place a protective covering on your floor.

*Notice: Due to the heavy weight, please assemble this recumbent bike more than two people.

1

Step1: Assembly Front/Rear Stabilizer to the Main Frame.

- 1). Using (2) M8x20mm screw and washer, attach the front stabilizer to the main frame.
- 2). Using (2) M8x20mm screw and (2) washer, attach the rear stabilizer to the main frame.

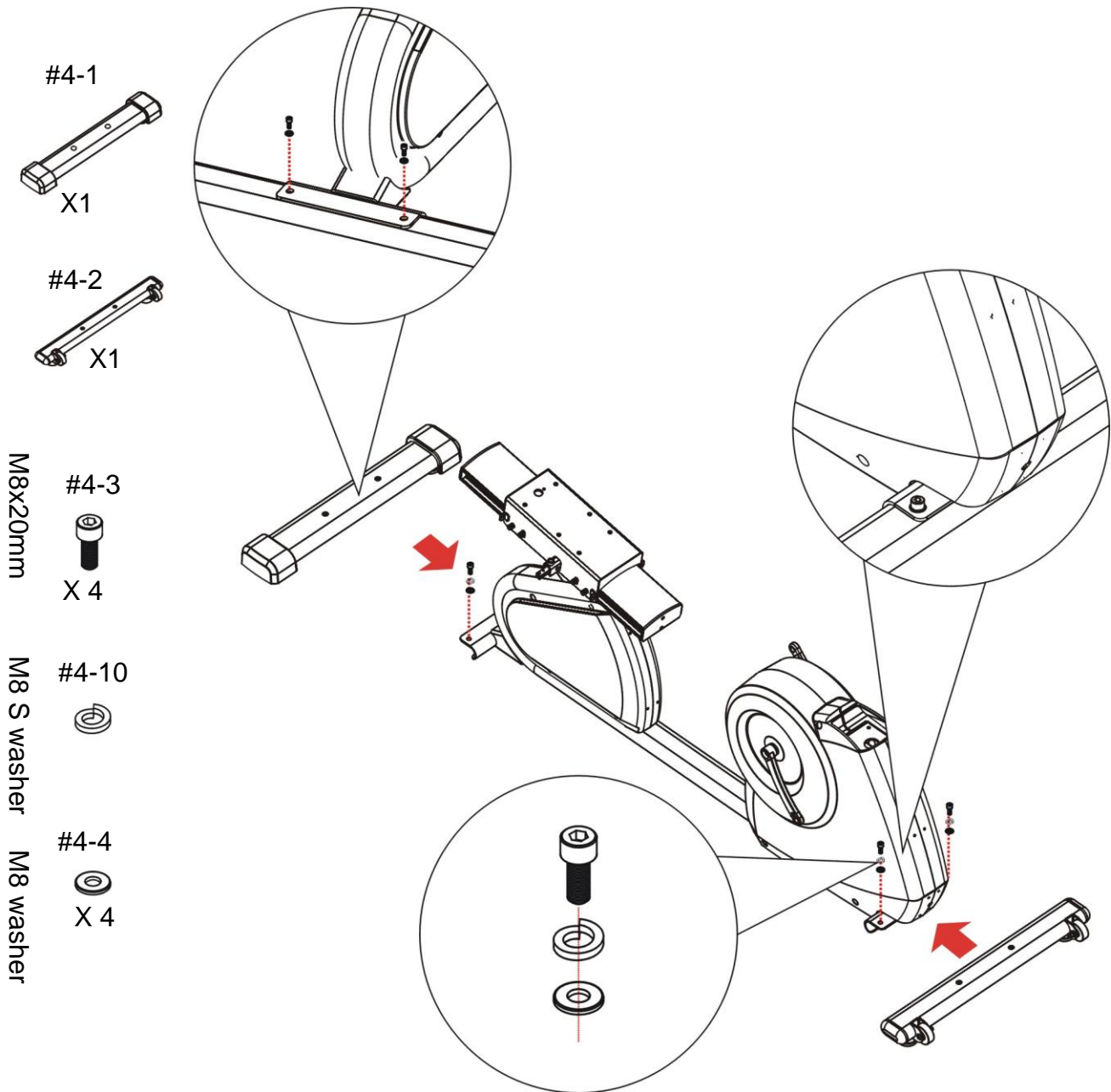

UNPACKING & ASSEMBLY

2

Step2: Assemble upright tube cover, right / left with handle bar post

1) Using wrench, fixing pedal set with crank set.

#4-5

#4-6



X1



X1

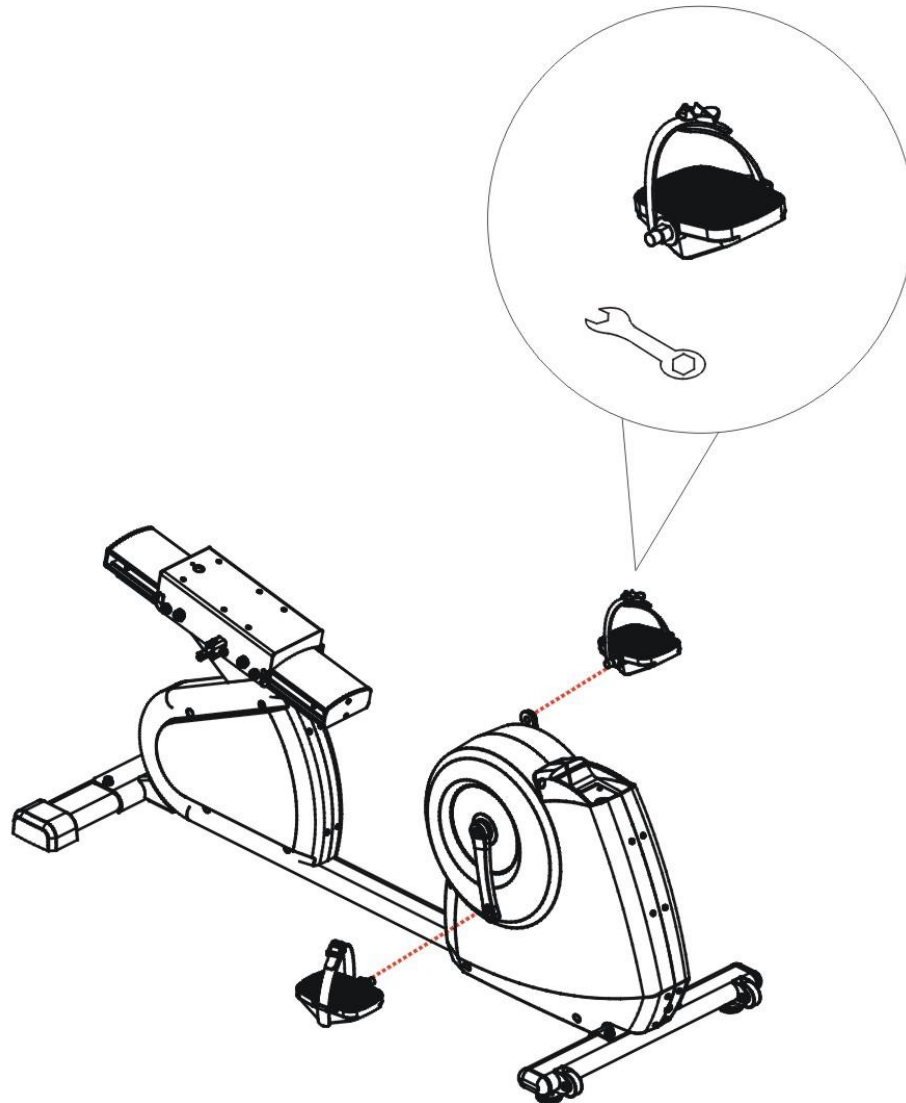

UNPACKING & ASSEMBLY

3

Step3: Assemble main frame and handle bar post.

- 1). Take the console wire and heart rate wire through handle bar post.
- 2). Put handle bar post into main frame and fasten (4) M8x20mm screws, (4) M8 Spring washers, (4) M8 flat washers and (1) M4x10mm screw on handle bar post.
- 3). Take front cover joint into handle bar post.

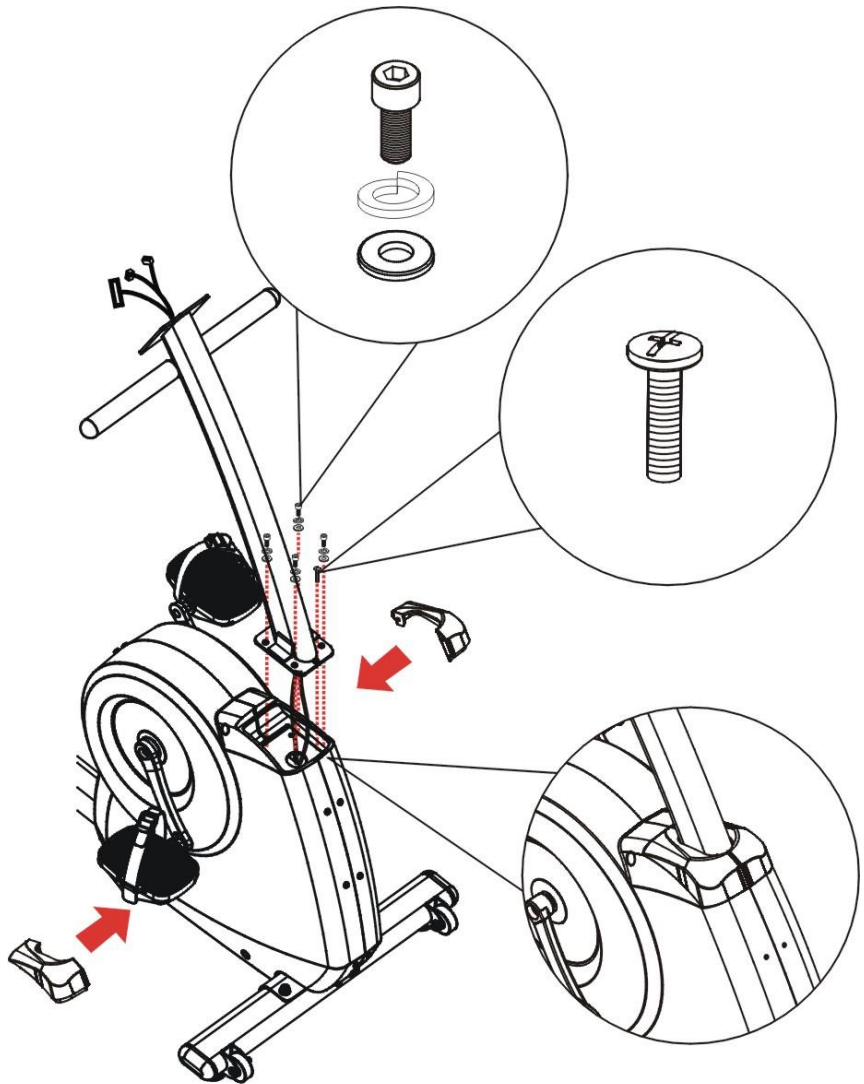
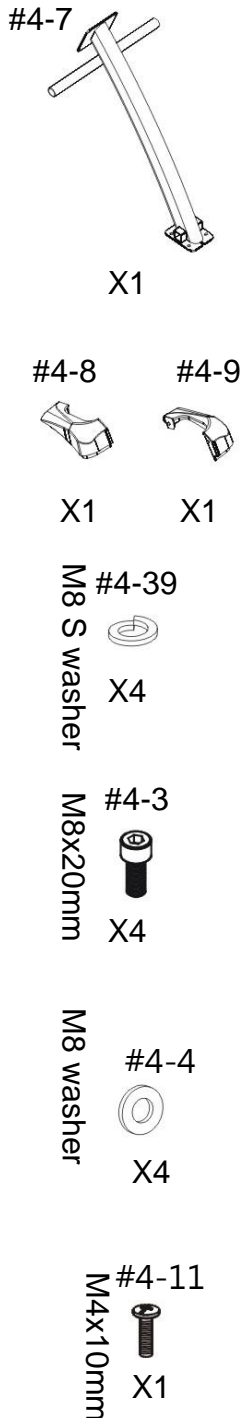

UNPACKING & ASSEMBLY

4

Step4: Assemble console with handle bar post

- 1). Put the console into handle bar post, connected upper console wire with lower console wire.
- 2). Using (4) M5x15mm screw, tighten all screws.

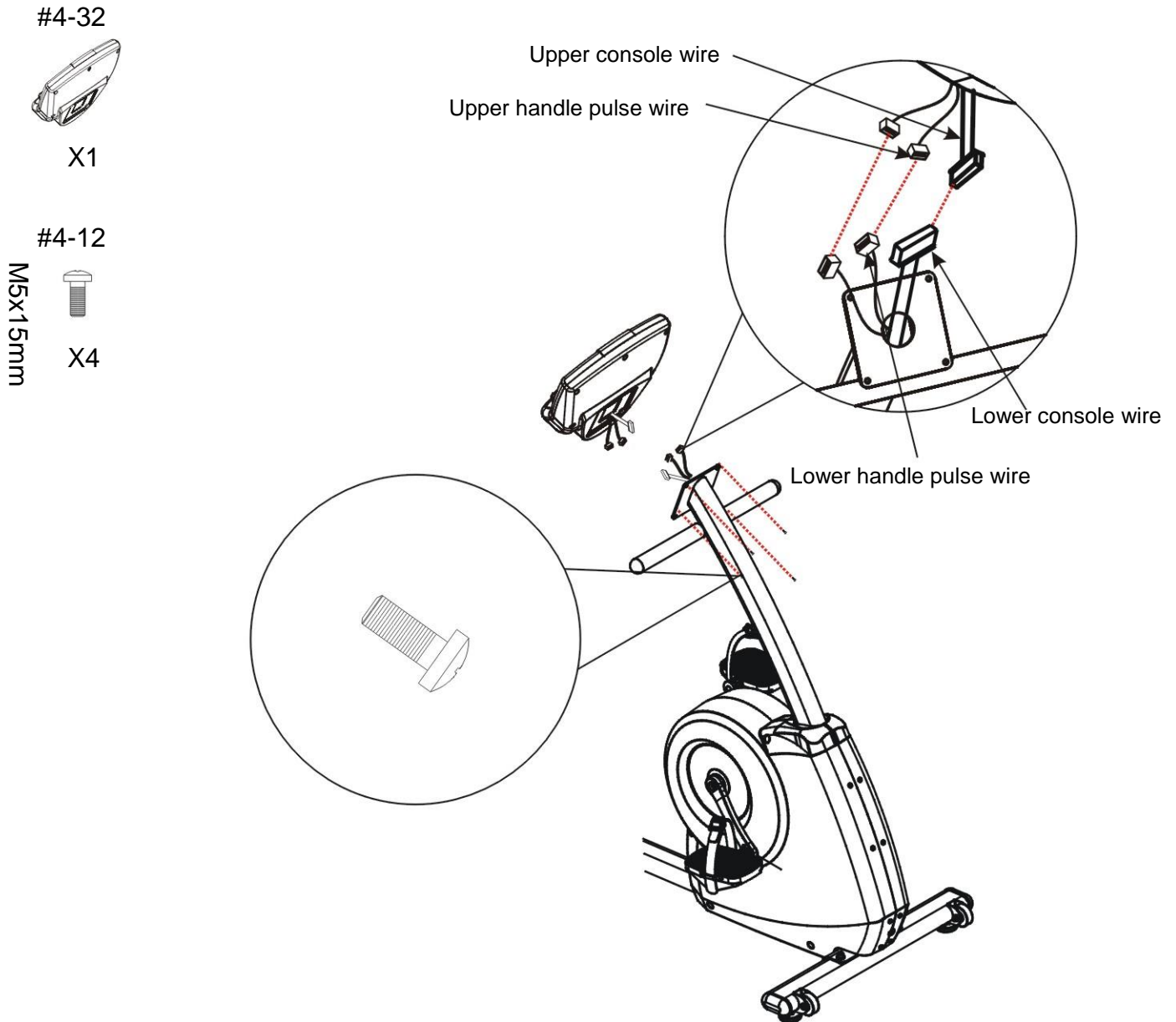

UNPACKING & ASSEMBLY

5

Step5: Assemble backrest frame and main frame.

- 1). Take out the backrest frame from box.
- 2). Set the backrest frame on main frame, then fasten backrest frame by (6) M10x25mm screws and (6) M10 spring washers.

#4-13

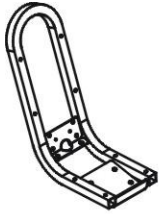

X 1

#4-14

M10x25mm



X6

#4-15

M10 S washer



X 6

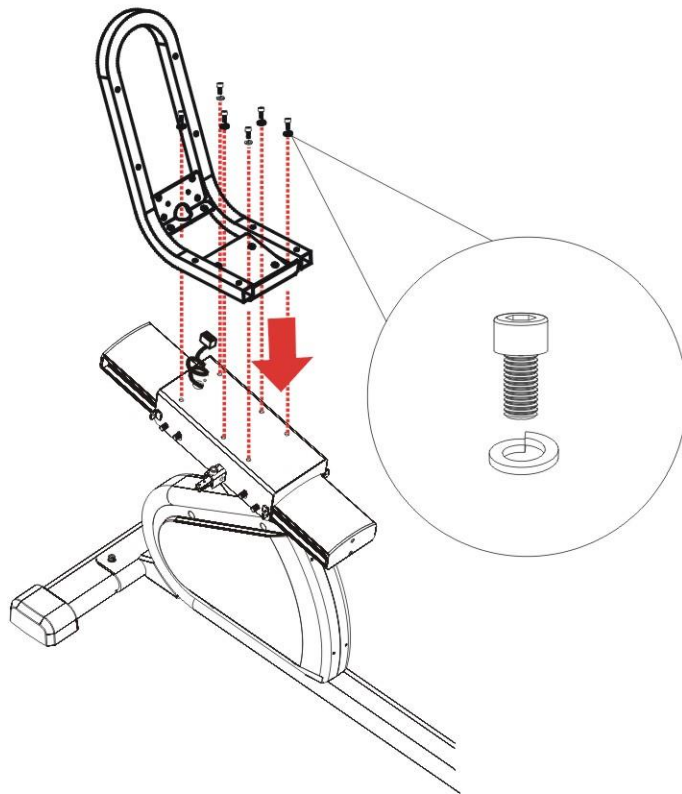

UNPACKING & ASSEMBLY

6

Step6: Assemble lower hand pulse and backrest frame.

- 1). Take out lower hand pulse from box.
- 2). Take hand pulse wire through the hole and connect hand pulse wire on the main frame.
- 3). Put the lower hand pulse on the backrest frame fasten by (4) M8x15mm screws and (4) M8 spring washers.

#4-20

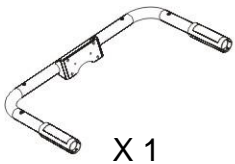

M8x15mm

#4-21



X 4

M8 S washer

#4-38



X 4

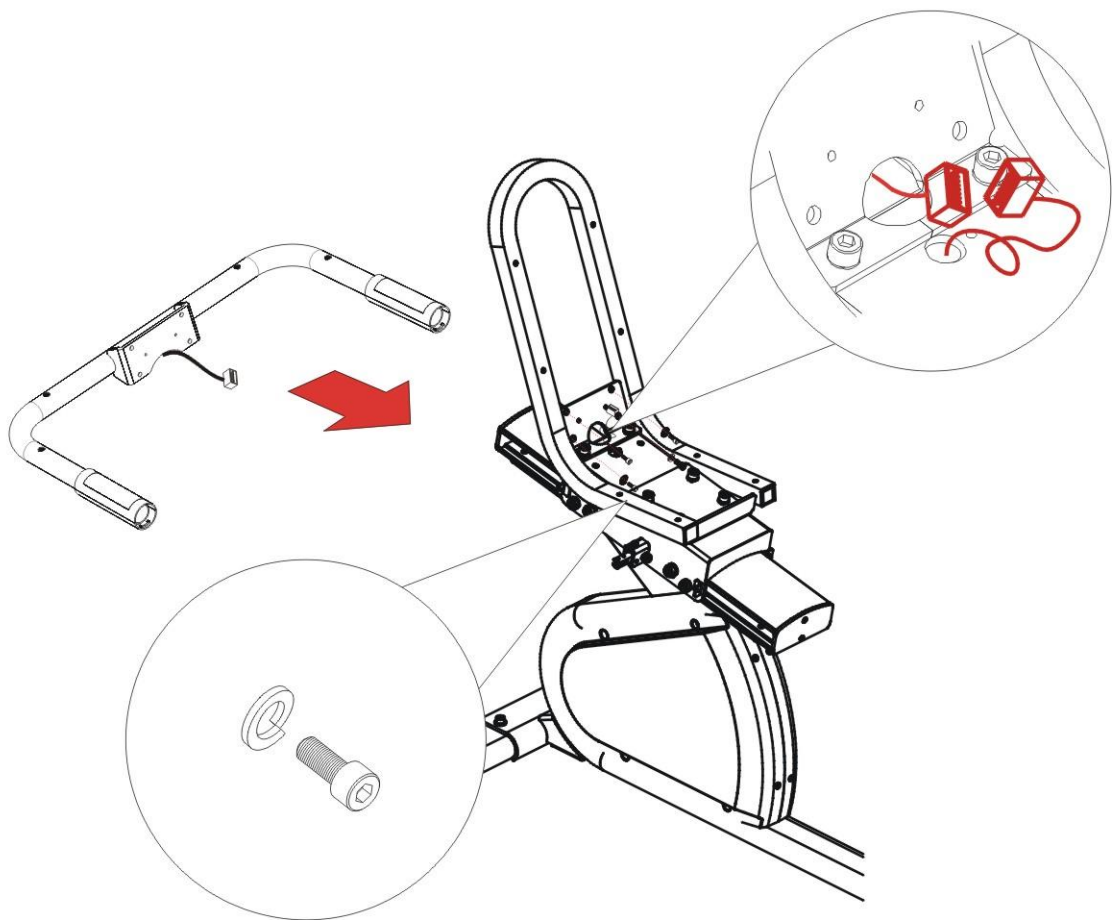

UNPACKING & ASSEMBLY

Z

Step7: Assemble seat bottom and backrest.

- 1). Take out seat bottom from box.
- 2). Set seat bottom on the backrest frame and fasten by (4) M6x40mm screws and (4) M6 spring washers.

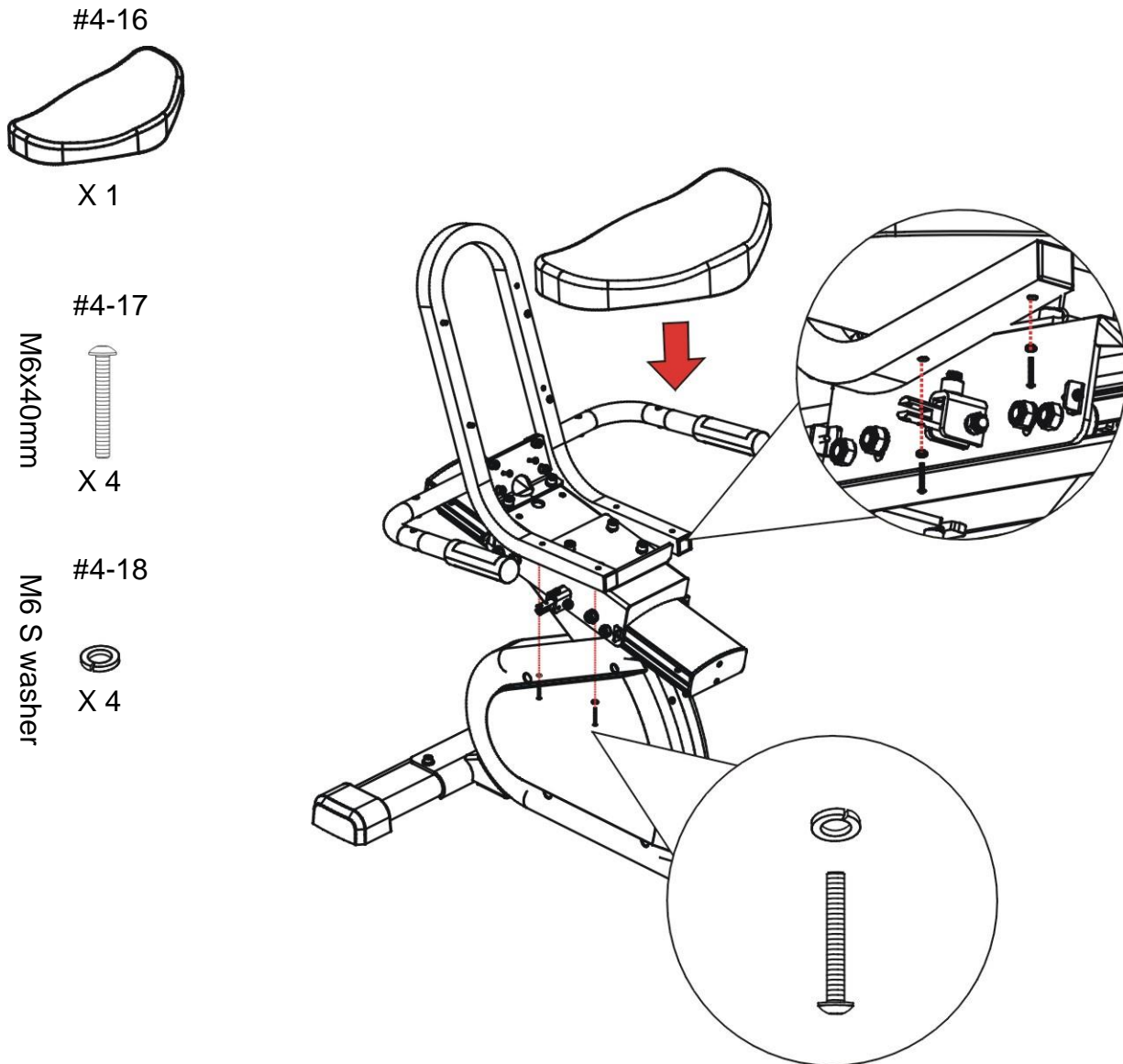

UNPACKING & ASSEMBLY

8

Step8: Assemble seat backrest and backrest frame.

- 1). Take out seat backrest from box.
- 2). Set seat backrest on backrest frame and fasten by (4) M6x40mm screws and (4) M6 spring washers.

#4-19

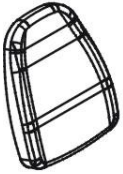

X 1

#4-17

M6x40mm



X 4

M6 #4-18



M6 S washer

X 4

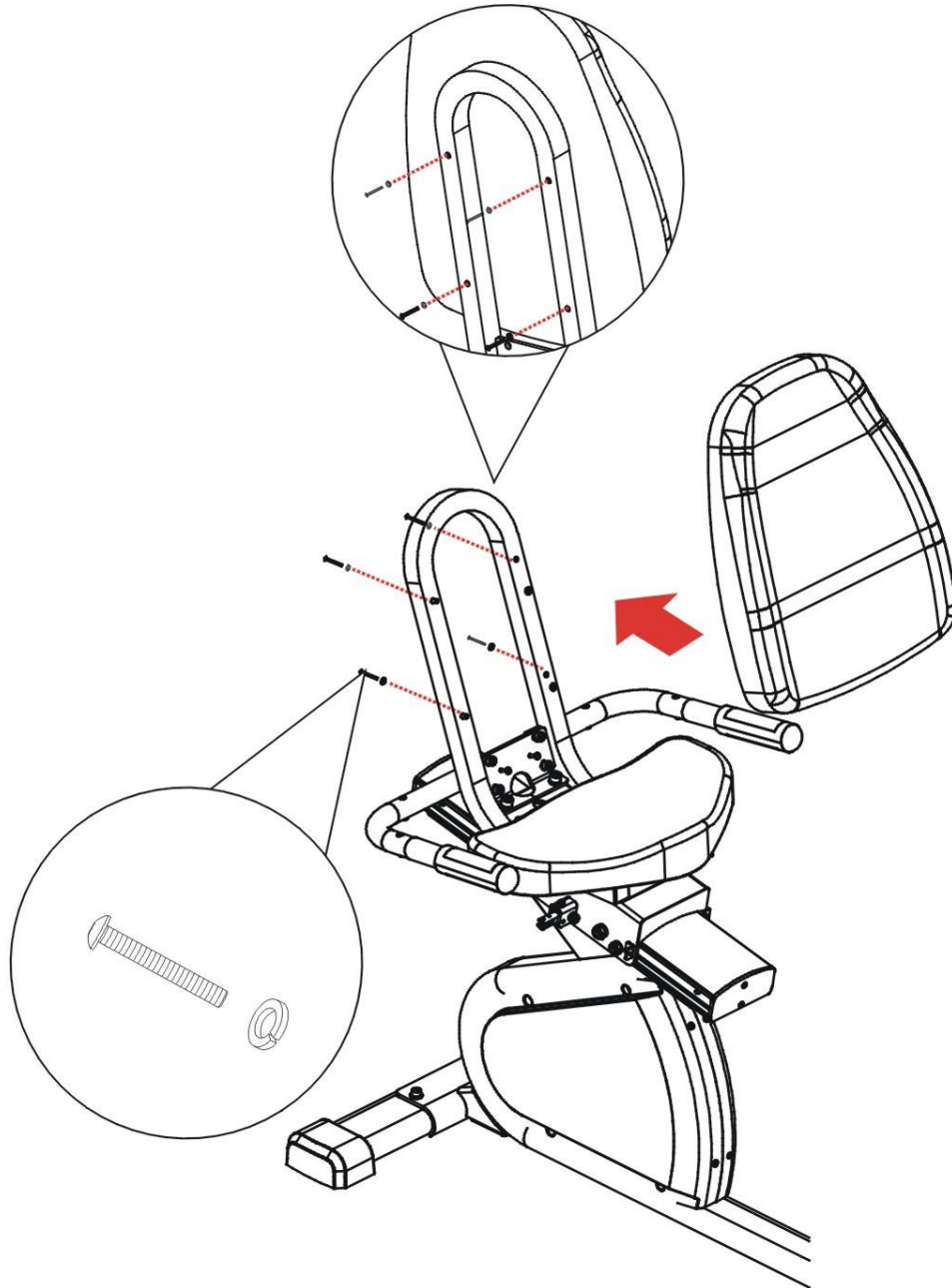

UNPACKING & ASSEMBLY

9

Step9: Assemble water bottle holder and lower hand pulse.

- 1). Take out the left and right water bottle holder from box.
- 2). Put the left water bottle holder on the lower hand pulse and fasten by (2) M4x12mm screws.
- 3). Put the right water bottle holder on the lower hand pulse and fasten by (2) M4x12mm screws.

#4-22



X 1

X 1

#4-24
M4x12mm
X 4



X 4

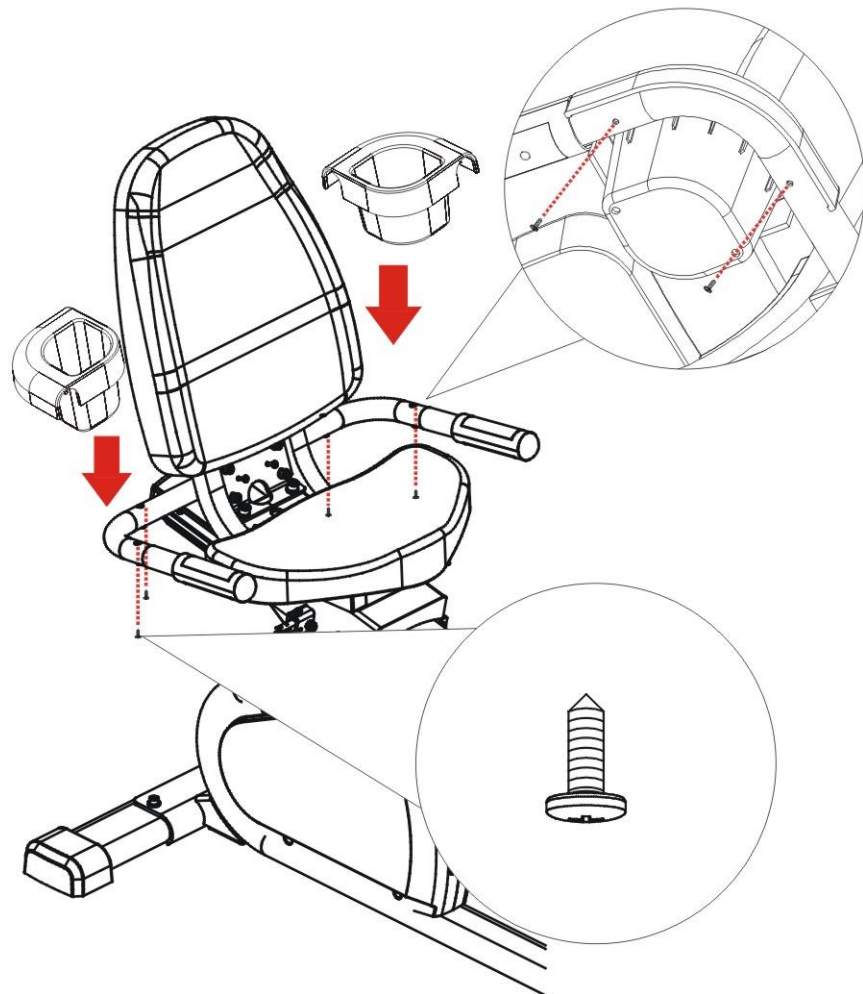

UNPACKING & ASSEMBLY

10

Step 10: Assemble backrest cover with seat set.

- 1). Fasten front backrest cover by (2) M4x20mm screws on the seat.
- 2). Fasten rear backrest cover by (2) M4x10mm screws on the seat.

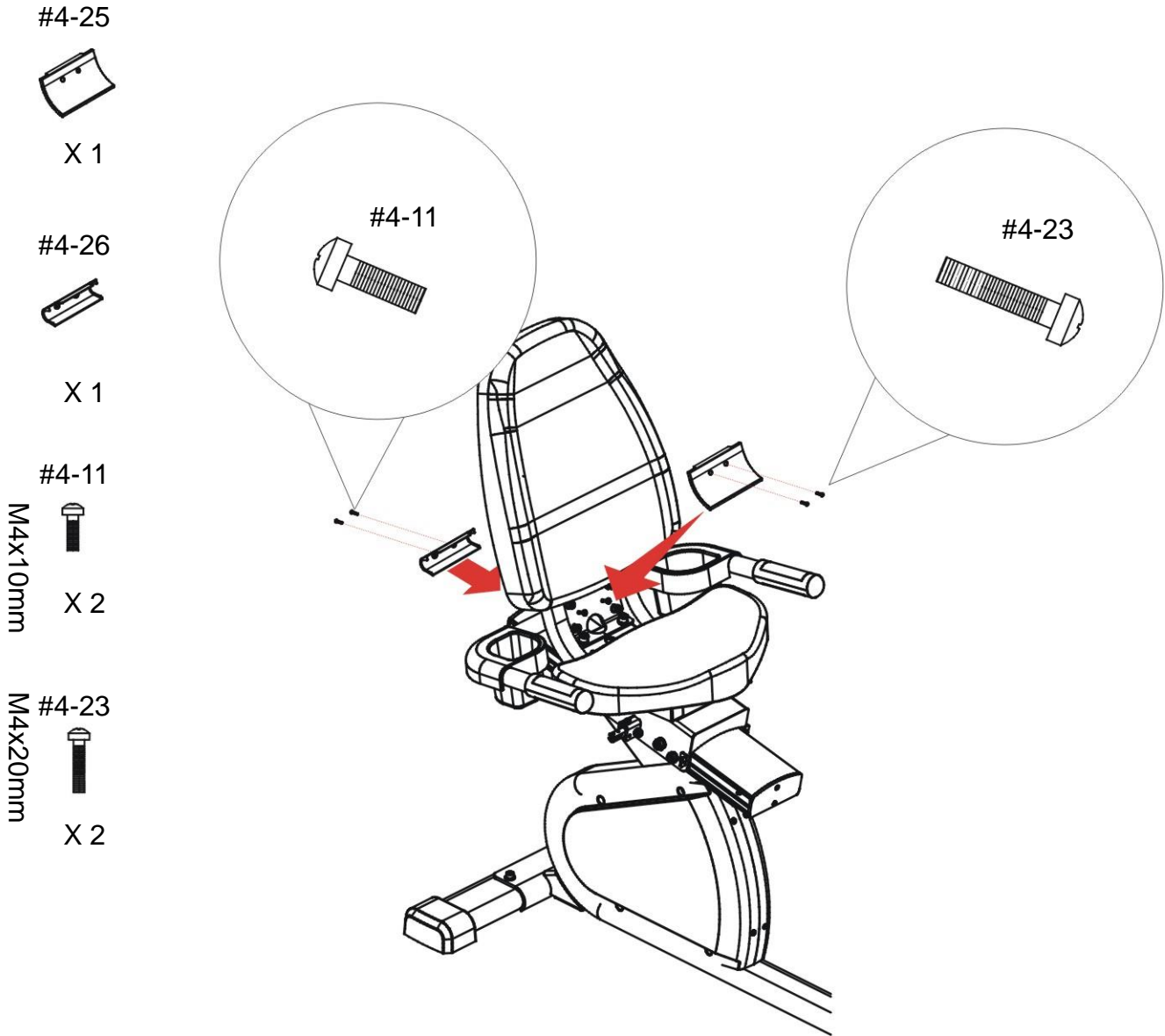

UNPACKING & ASSEMBLY

11

Step 11: Assemble left/right track cover on the seat set.

- 1). Fasten left track cover by (2) M4x10mm screws on the seat set.
- 2). Fasten right track cover by (2) M4x10mm screws on the seat set.

#4-28 #4-27



X 1 X 1

M4x10mm #4-11



X 4

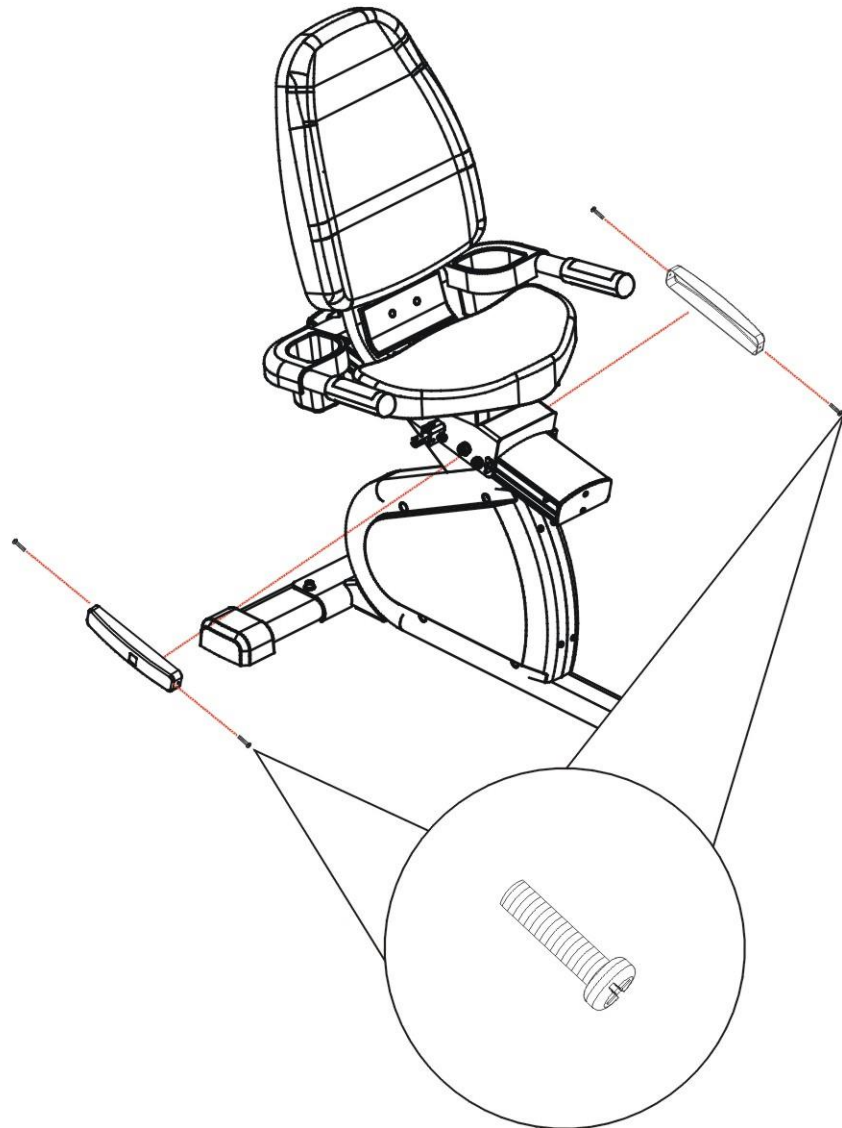

UNPACKING & ASSEMBLY

12

Step 12: Assemble seat adjust lever and seat set.

- 1) Fasten seat adjust lever on the seat set by (2) M4x18mm screws.

#4-29

#4-30



X 1

#4-31

M4x18mm



X 2

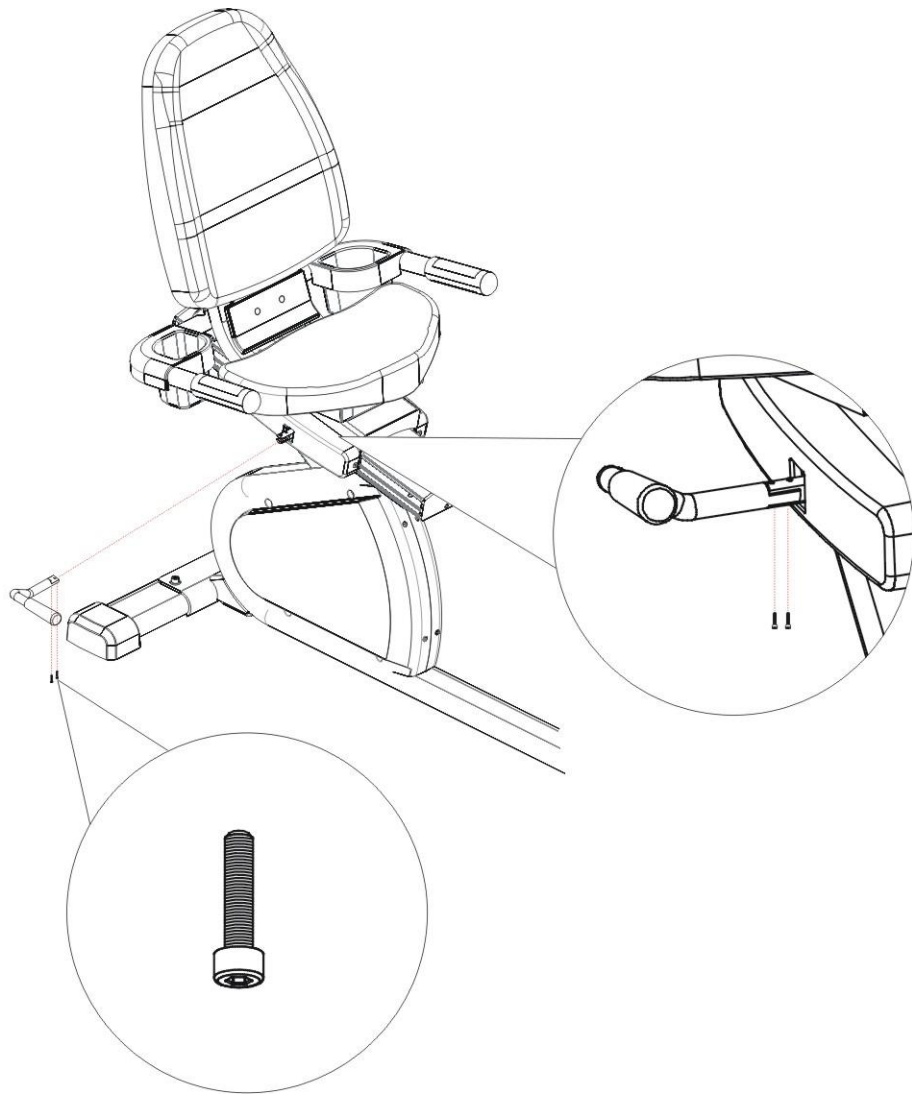

UNPACKING & ASSEMBLY

13

Step 13: Assemble adjust pad and main frame.

- 1). Left up the main frame.
- 2). Fasten the adjust pad under the main frame.

#1-7



X 1

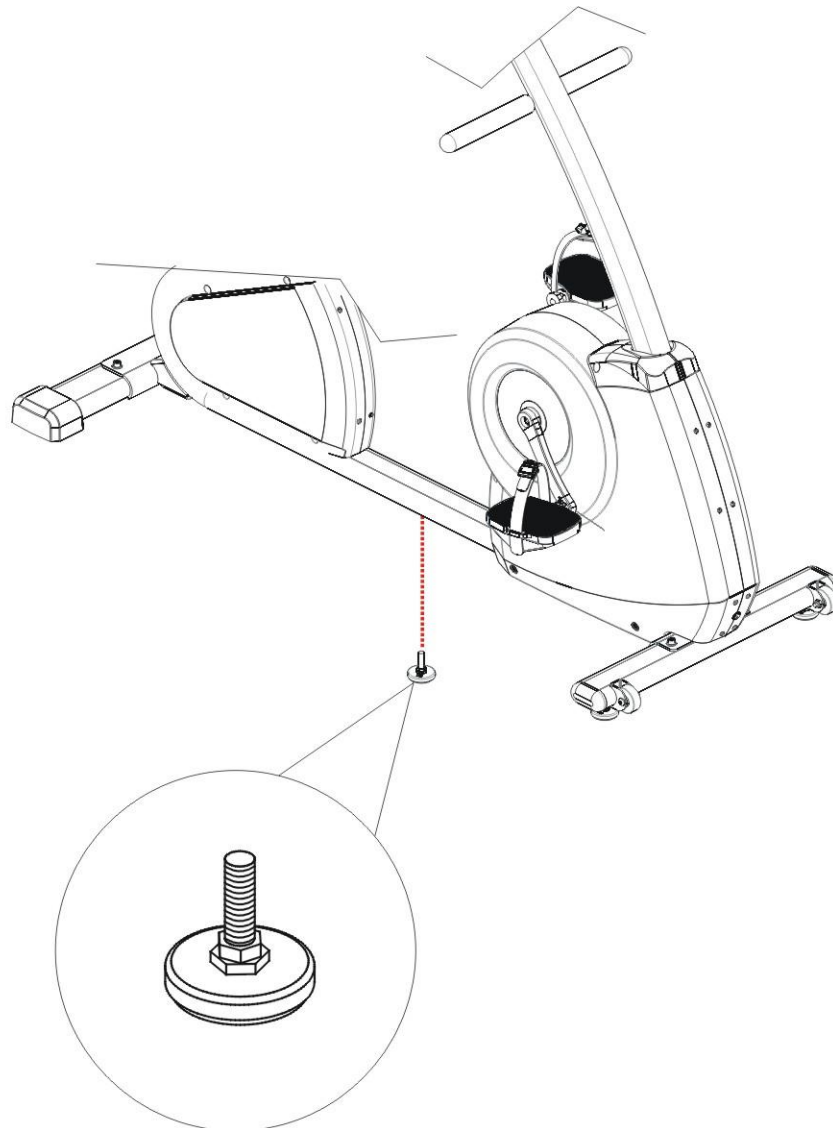

WARM UP & COOL DOWN

A successful exercise program consists of a warm up, aerobic exercise and a cool down. Warming up is an important part of your workout, and should begin every session. It prepares your body for more strenuous exercise by heating up and stretching out your muscles. At the end of your workout, repeat these exercises to reduce sore muscle problems. We suggest the following warm-up and cool-down exercises:



HEAD ROLLS

Rotate your head to the right for one count, feeling the stretch up the left side of your neck. Next rotate your head back for one count, stretching your chin to the ceiling and letting your mouth open. Rotate your head to the left for one count, and finally, drop your head to your chest for one count. Repeat this action for several times.



SHOULDER LIFTS

Lift your right shoulder up toward your ear for one count. Then lift your left shoulder up for one count as you lower your right shoulder. Repeat this action for several times.



QUADRICEPS STRETCH

With one hand against a wall for balance, reach behind you and pull your right foot up. Bring your heel as close to your buttocks as possible. Hold for 15 seconds and repeat with left foot up.



SIDE STRETCHES

Open your arms to the side and continue lifting them until they are over your head. Reach your right arm as far upward toward the ceiling as you can for one count. Feel the stretch up your right side. Repeat this action with your left arm.



CALF/ACHILLES STRETCH

Step your right foot in front of your body. Lean against a wall with your arms and stretch your left foot backward your body. Bend forwards your right foot, and slightly push your buttock toward to the wall for 15 seconds. Repeat the action with front left foot and rear right foot for another 15 seconds.



INNER THIGH STRETCH

Sit with the soles of your feet together with your knees pointing outward. Pull your feet as close into your groin as possible. Gently push your knees toward the floor. Hold for 15 seconds. Repeat this action 3-5 times.



TOE TOUCHES

Slowly bend forward from your waist, letting your back and shoulder relax as you stretch toward your toes. Reach down as far as you can and hold for 15 seconds.



HAMSTRING STRETCHES

Keep your right leg straight and the left foot on the floor; try to stretch your right hand toward the toe, hold this posture for 15 seconds. Relax, and then repeat the action for left leg.

OPERATION

A. After assembly, the rear stabilizer can be adjusted to accommodate slightly uneven ground. Turn the adjustment knobs on the ends of the rear foot caps to level the rear stabilizer to the floor.

B. Adjust seat set.

Pull up the adjust lever to slide forward or backward from the scale 3 to 13 and adjust seat position according user's height.

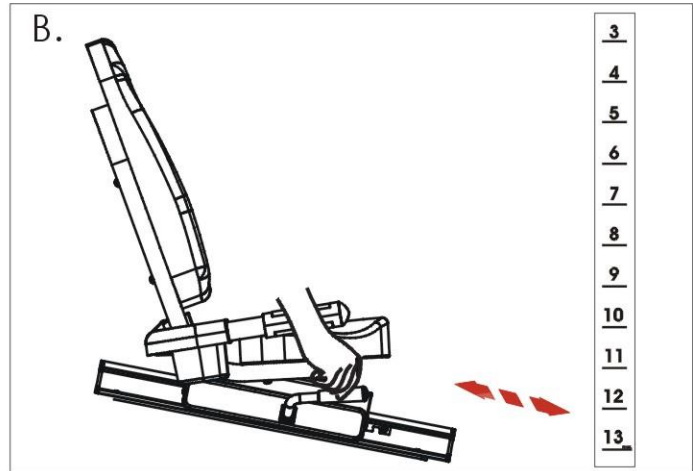
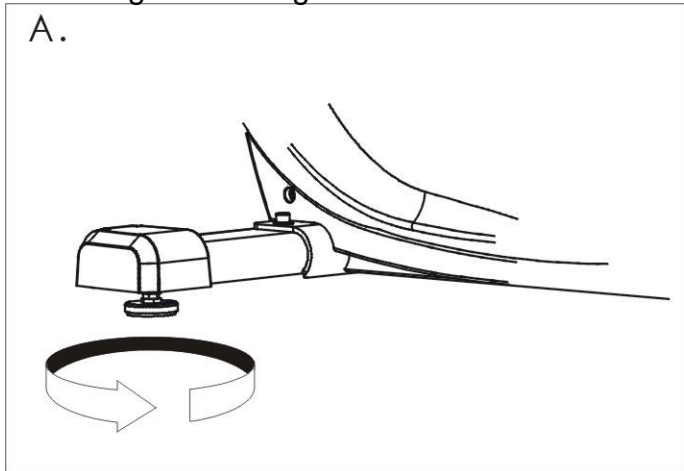

C. The transportation wheels on the front foot caps allow for easy maneuvering. Simply lift up on the rear stabilizer bar until the wheels touch the floor. Then roll the unit to a desired location.

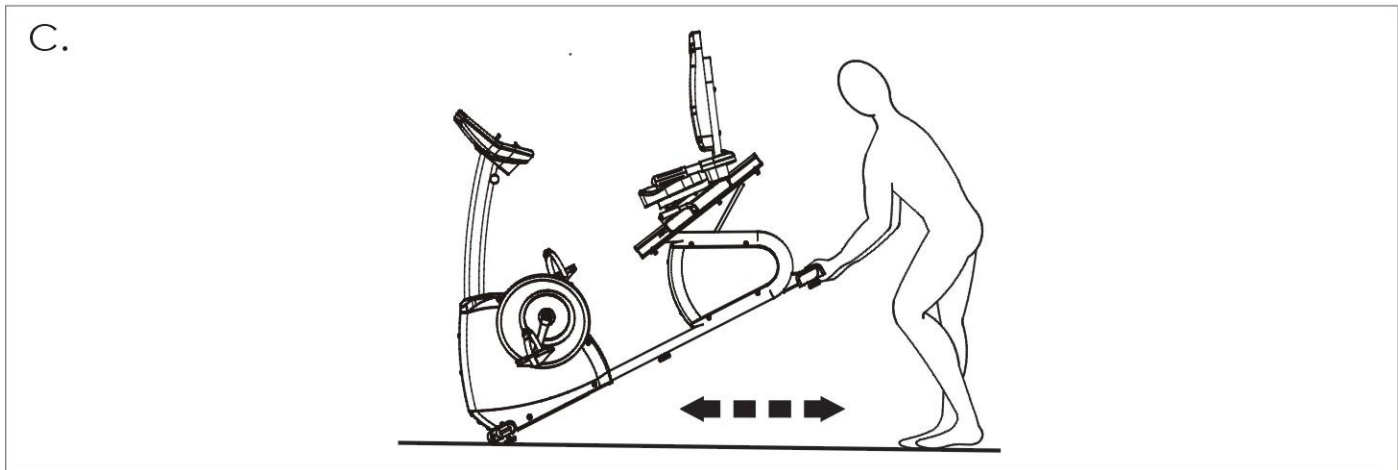

PANEL CONTROL

Display & Keys

Dot-matrix, display program profiles & message



PANEL CONTROL

Display function

Display	Definition
Time	Displays time remaining or total time.
Calories	Displays calories burned.
Heart Rate	Displays hand grip and wireless Heart Rate reading.
Distance	Displays total distance KM/Mi.
RPM	Displays pedaling RPM.
Watts	Displays consuming watt.
Mets	Displays the multiple of rest.
Metabolic Rate	Displays the multiple of rest.
Level	Displays current resistance level L1~L16

※ Calories & Heart Rate for reference only.

Key function

Key	Function
Start	Quick start or program start.
▲	Adjust workload up. Adjust value when program setting. Select program
▼	Adjust workload down. Adjust value when program setting. Select program
Display	RPM←→Watt Calories←→Distance Time←→Mets Level←→Heart Rate
Enter	Confirm value entered.
Rest	Reset back to idle mode while pause
Program	Select program directly

Keypad

Set value

PROGRAM

PROGRAMS DESCRIPTION

1. QUICK START

- 1.1 To pedal over 30 rpm to wake up and initial the system to idle mode, press 『 START 』 to quick start.
- 1.2 Press shift UP or DOWN to exercise level by 1 level or press quick Level Key to change level.
- 1.3 Stop pedaling will pause the system, stop pedaling over 30 seconds system will auto shut down.

2. Target

2.1. Press 『 Target 』 key to enter the program.

- 2.1.1. Set time : use shift up or down device to set time then press 『 ENTER 』 to next settings.
- 2.1.2. Set weight: use shift up or down device to set weight then press 『 ENTER 』 to next settings.
- 2.1.3. Set age: use shift up or down device to set age then press 『 ENTER 』 to next settings.
- 2.1.4. Set distance: use shift up or down device to set distance then press 『 ENTER 』 to next settings.
- 2.1.5. Set calories: use shift up or down device to set calories then press 『 START 』 to begin workout.

2.2. Beginning the workout:

- 2.2.1. If either, Time, Distance and Calories are set the program will count down. Once the preset value reaches 0 the program will end. If no goal is set the program will not end unless manually stopped.

3. Preset program :

3.1. There are 5 preset programs, ROLLING, VALLEY, FAT BURN, INTERVAL, RANDOM. Press their own program key to enter the program.

- 3.1.1. Set time : use shift up or down device to set time then press 『 ENTER 』 to next settings.
- 3.1.2. Set weight: use shift up or down device to set weight then press 『 ENTER 』 to next settings.
- 3.1.3. Set age: use shift up or down device to set age then press 『 ENTER 』 to next settings.
- 3.1.4. Set workout level: use shift up or down device to set level 1~5 (For RANDOM program will change the profile randomly. Press 『 START 』 to begin workout.

3.2. Beginning the workout:

3.2.1. The resistance level will change automatically according to the program settings, the resistance level will change every 2 minutes per segment if the time is in count up mode, if time is entered during setup then the segment time=set time / 16. You can use any speed or incline key to change speed or incline during your workout.

3.2.2. The program will end when the counter reaches 0.

3.2.3. Preset program profiles:

P1=ROLLING \ P2=VALLEY \ P3=FAT BURN \ P4=INTERVAL \ P5= RANDOM

P	SEG	1	2	3	4	5	6	7	8	9	10	11	12	13	14	15	16
P1	LEVEL 1	4	6	8	8	6	4	4	6	8	8	6	4	4	6	8	6
	LEVEL 2	5	6	8	9	9	8	6	6	7	9	8	7	6	6	7	8
	LEVEL 3	7	8	9	10	10	8	8	6	8	10	10	9	8	6	8	10
	LEVEL4	9	10	11	13	10	8	11	13	10	9	8	10	11	13	10	9
	LEVEL5	11	13	15	15	13	11	11	13	15	15	13	11	11	13	15	12
P2	LEVEL 1	8	8	6	6	4	4	2	2	2	2	4	4	6	6	8	8
	LEVEL 2	9	6	5	4	3	2	2	4	6	6	7	10	10	11	11	12
	LEVEL 3	11	10	10	8	7	6	5	4	3	3	5	5	7	10	10	13
	LEVEL4	13	12	12	10	9	8	6	6	6	7	8	9	10	12	12	14
	LEVEL5	15	15	12	12	10	10	8	8	8	8	10	10	12	12	15	15
P3	LEVEL 1	2	2	4	4	6	6	8	8	8	8	6	6	4	4	2	2
	LEVEL 2	3	5	5	7	8	9	10	10	11	12	10	10	7	6	3	3
	LEVEL 3	5	6	7	7	9	10	10	12	12	12	10	10	8	8	5	5
	LEVEL4	6	6	8	8	11	11	13	14	14	12	10	10	9	8	6	6
	LEVEL5	8	8	10	10	12	12	15	15	15	15	12	12	10	10	8	8
P4	LEVEL 1	2	4	8	4	2	2	4	8	4	2	2	4	8	4	2	2
	LEVEL 2	3	5	8	6	1	1	5	7	6	3	3	3	6	6	4	3
	LEVEL 3	5	7	9	9	6	5	4	4	4	6	7	8	10	8	6	6
	LEVEL4	7	8	10	10	12	12	10	10	8	8	10	12	12	10	8	8
	LEVEL5	8	10	15	10	8	8	10	15	10	8	8	10	15	10	8	8

PROGRAM

4. HRC(Heart Rate Control)

- 4.1. Press 『H.R.C』 key to enter the program.
- 4.2. Set time : use shift up or down device to set time then press 『ENTER』 to next settings.
- 4.3. Set weight: use shift up or down device to set weight then press 『ENTER』 to next settings.
- 4.4. Set age: use shift up or down device to set age then press 『ENTER』 to next settings.
- 4.5. Set workout mode: There are 3 types of HRC mode. 『WEIGHT LOSS MODE』 , 『AEROBIC MODE』 , 『TARGET MODE』 , use shift up or down device to select the desired HRC type then press 『ENTER』 to next settings.
- 4.6. Set target heart rate: use shift up or down device to set Target Heart Rate(WEIGHT LOSS MODE default value=MHR 70%, setting range=MHR 66%~75%. AEROBIC MODE default value=MHR 80%, setting range=MHR 76%~85%, TARGET HEART RATE default value=130, setting range=100~180) then press 『ENTER』 to next settings.
- 4.7. Set begin resistance level: use shift up or down device to set LEVEL then press 『START』 to begin workout.
- 4.8. Beginning the workout:
 - 4.8.1 The program will compare the real time and preset target heart rate every 30 seconds to adjust resistance level until the actual heart rate is reaches with in + or – 5 beats of the preset target heart rate.
 - 4.8.2 During the program, if the actual pulse rate \leq target workout heart rate minus 5, the resistance level will be increased one level every 30 seconds until the max. level.
 - 4.8.3 During the program, if the actual pulse rate \geq target workout heart rate plus 5, the resistance level will be decreased one level every 30 seconds until the min. level.
 - 4.8.4 You can use any resistance level key or device to change the resistance level during your workout.

4.8.5 The program will end when the counter reaches 0.

PROGRAM

5. Fitness Test :

5.1. Press 『 Fitness Test 』 key to enter the program.

5.2. Set weight: use shift up or down device to set weight then press 『 ENTER 』 to next settings.

5.3. Set age: use shift up or down device to set age then press 『 START 』 to begin workout.

5.4. Beginning the workout:

5.4.1. There are 10 stages at most, 3 minutes per stage, first stage(0~3 min) the wattage preset value=55W, the preset wattage value from stage 2~10 depend on average heart rate value of first stage, shown as below:

2:01-3:00 AVG. HR Stage	< 80bpm	80-89bpm	90-100bpm	>100bpm
2 – (3:01~6:00)	125W	100W	75W	55W
3 – (6:01~9:00)	150W	125W	100W	75W
4 – (9:01~12:00)	175W	150W	125W	100W

5 – (12:01~15:00)	200W	175W	150W	125W
6 – (15:01~18:00)	225W	200W	175W	150W
7 - (18:01~21:00)	250W	225W	200W	175W
8 - (21:01~24:00)	-----	250W	225W	200W
9 - (24:01~27:00)	-----	-----	250W	225W
10 - (27:01~30:00)	-----	-----	-----	250W

5.4.2. Can not adjust the resistance level manual, program will auto change the level according to the preset rules.

5.4.3. The program will end while heart rate value reach or over MHR 85% - 10 for 10 seconds. The program will show you the VO2 MAX value.

EQUIPMENT ADJUSTMENTS

Equipment adjustments

An optimal seating position is crucial for comfortable cycling.

- **Height of seat**

As a general rule you should be able to reach the pedal with your heel when straightening your leg and aligning it with the pipe supporting the seat.

- **Body position**

Your handlebars should be set to a position in which you can reach them with slightly bent arms.

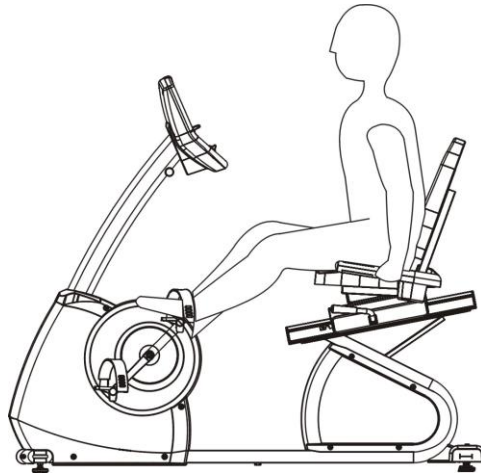

PREVENTATIVE MAINTENANCE

HOW TO CARE FOR YOUR RECUMBENT BIKE

The Safety of the equipment can be maintained only if the equipment is examined regularly for damage or wear. If maintenance is required, keep the equipment out of use until defective parts are repaired or replaced.

Pay special attention to parts that are subject to wear as outlined in the *Preventative Maintenance Schedule*.

The following preventive maintenance will keep the recumbent bike operating at peak performance :

- Locate the equipment in a cool, dry place.

- Clean the top surface of the pedals regularly.
- Keep the display console free of fingerprints and salt build-up caused by sweat.
- Use a 100% cotton cloth, lightly moistened with water and mild liquid cleaning product, to clean the equipment, other fabrics, including paper towels, may scratch the surface
- Clean the housing thoroughly on a regular basis.

The recumbent bike can be wiped clean with a soft cloth and mild detergent. **Do not use abrasives or solvents.** To prevent damage to the console, keep liquids away from the console and keep the console out of direct sunlight.



Preventative Maintenance Schedule

Follow the schedule below to ensure proper operation of the product.

ITEM	WEEKLY	MONTHLY	BI-ANNUALLY	ANNUALLY
Display Console	C	I		
Console Mounting Bolts			I	
Accessory Tray	C	I		
Frame	C			I
Plastic Covers	C	I		
Pedals and Straps	C	I		
KEY : C=Clean; I=Inspect				

Hand pulse

Before/after running, to put your feet separately on each side rein, then hold the hand grip, so as to avoid any shaking. If the heart beat is too high or irregular, please have your hands out of the hand grip until the pulse display returns to " 0 ", then redoing the test. Don't do this test while running.

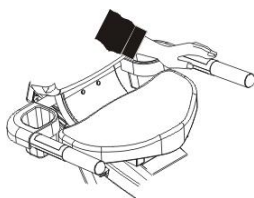

PART LIST

ITEM	Part No.	DESCRIPTION	Q'TY	ITEM	Part No.	DESCRIPTION	Q'TY
1-1	F500362-002	Main frame /K90	1	TRACK SET			
1-2	F500363-000	Idler set	1	2-1	F500322-003	Rack set	1
1-3	H020105-000	Bolt M5x15mm	1	2-2	F500323-000	Rack wheel set	4
1-4	H029400-000	Spring	1	2-3	F205014-000	Track	1
1-5	F373336-000	Flywheel	1	2-4	F270453-000	Set plate	1
1-6	F240009-001	Crank (left)	1	2-5	F270486-002	Plate	2
1-7	F300359-000	Adjust pad	5	2-6	F290079-000	Latch	1
1-8	F373357-000	Motor control	1	2-7	F916295-000	Stud	2
1-9	F083118-000	Adapter	1	2-8	F300551-000	Slide wheel	8
1-10	F300556-000	PC Plate isolation /KSS/CS-0305S	4	2-9	H020501-000	Bolt M10x10mm	1
1-11	F371001-000	Lead-Acid Battery	1	2-10	H020626-003	Bolt M8x20mm /K90	6
1-12	F080115-000	Lead-Acid Battery Wire	1	2-11	H021209-000	S washer M8 /K90	6
1-13	H020803-001	Bolt M4x10mm	22	2-12	H021100-000	Washer M8 /K90	6
1-14	H022111-006	Nut M6	2	2-13	H020309-000	Bolt M4x10mm	4
1-15	H023121-001	C-ring	3	2-14	H020802-008	Bolt M5x10mm	3
1-16	H050063-000	Ball Bearing 6005	2	2-15	H021608-000	Washer M10	4
1-17	H041017-000	Drive belt 480PJ8	1	2-16	H022303-003	Nylon nut M10	8

4-20	F970209-001	Lower handlebar set	1				
4-20-1	F500385-000	Lower handlebar	1				
4-20-2	F300281-000	Hand pulse lower cover	2				
4-20-3	F300341-000	Hand Pulse upper cover	2				
4-20-4	H020109-014	Bolt M3x20L	4				
4-20-5	F270271-000	Hand pulse plate	4				
4-20-6	F300364-000	Hand pulse cap	2				
4-21	H020603-000	Bolt M8*15mm	4				
4-22	F300480-100	Water bottle holder	2				
4-23	H020803-006	Bolt M4*20mm	2				
4-24	H020202-003	Bolt M4*12mm	4				
4-25	F300481-001	Backrest rear cover	1				
4-26	F300482-100	Backrest rear cover	1				
4-27	F300476-000	Track cover (left)	1				
4-28	F300477-000	Track cover (right)	1				
4-29	F290077-000	Adjust lever	1				
4-30	F290078-003	Seatback adjustment Holder	1				
4-31	H020659-003	Bolt M4*18mm	2				
4-32	F970158-020	Console set	1				
4-33	F080140-000	Handle pulse wire -1	1				
4-34	F080191-000	Lower console wire	1				
4-35	F080141-000	Handle pulse wire -2	1				
4-36	F080142-000	Handle pulse wire -3	1				
4-37	F300479-000	Stopper	2				
4-38	H021209-000	M8 S Washer	4				
4-39	H021209-000	M8 S Washer	4				

EXPLODED DRAWING

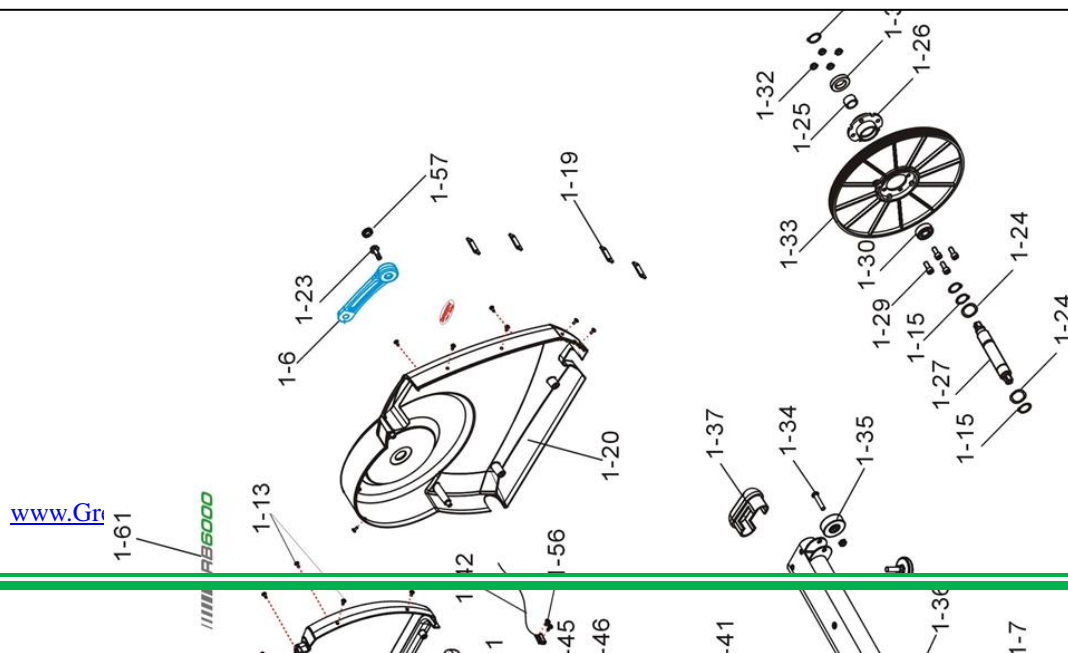

EXPLODED DRAWING (CONSOLE SET)

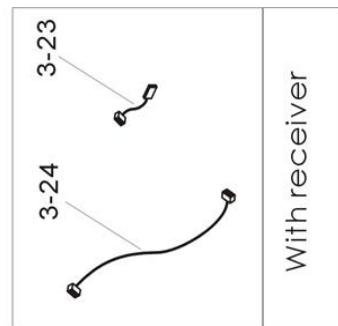
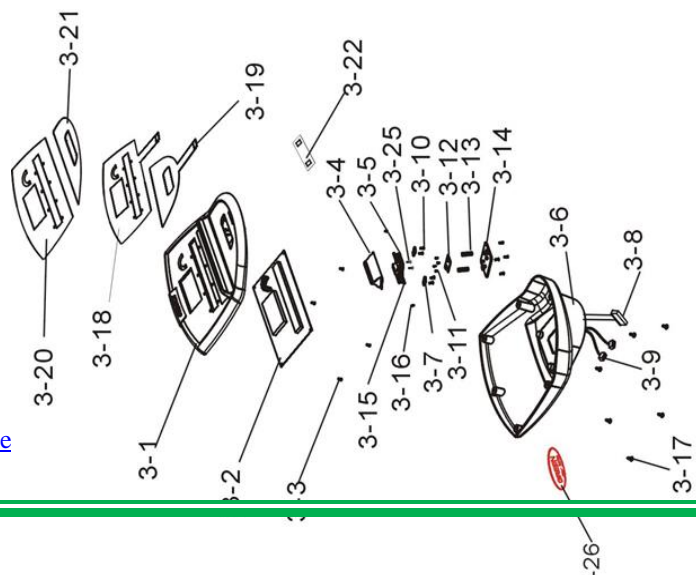

EXPLODED DRAWING (CONSOLE MAST SET)

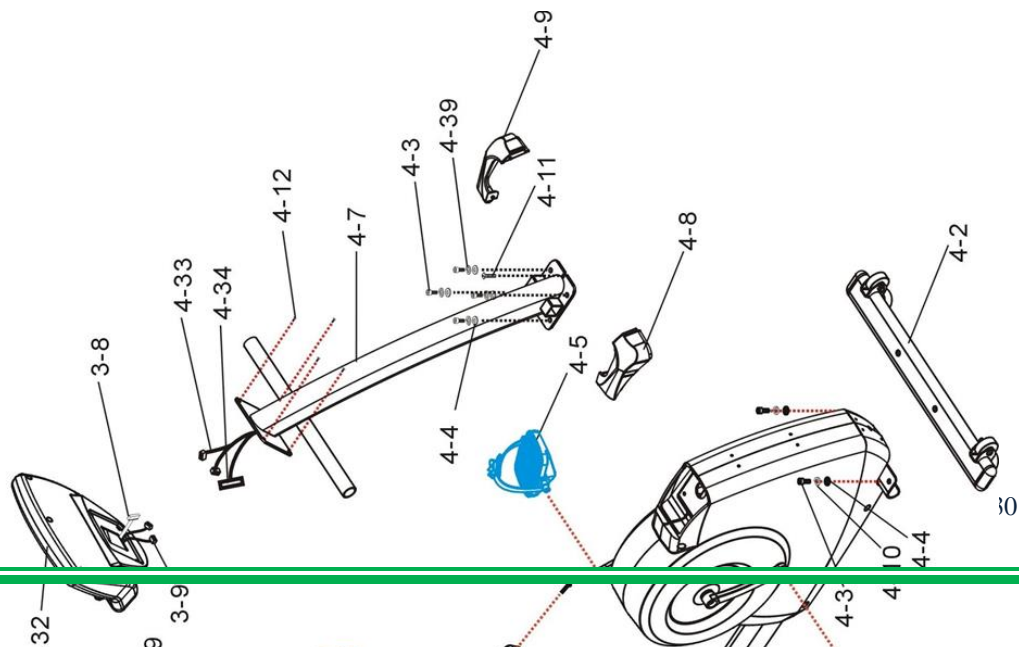



Limited Warranty

6000 SERIES LIGHT COMMERCIAL WARRANTY

The Green Series™ 6000 light commercial warranty is intended for non-dues-paying facilities where equipment use is generally up to eight (8) hours per day.

www.GreenSeriesFitness.com

©April 2017
CIR-RB6000-G1 Revision 1.3

Call Toll free at (800) 269-7130

7000 SERIES FULL COMMERCIAL WARRANTY

The Green Series™ 7000 full commercial warranty is intended for facilities where equipment use is regularly in excess of eight (8) hours per day. All dues-paying facilities fall into the category of a full commercial warranty as well as many non-dues-paying facilities.

Please note that any warranty services or questions must be accompanied by the model number and serial number from the transaction through which the warranted product was purchased. ***The serial number serves as your warranty number and must be retained.*** GREEN SERIES™ cannot provide warranty service without this number.

GREEN SERIES™ Cardio Machines warrant this product and its parts against defects in materials or workmanship for ***ten (10) years frame, five (5) years motor, three (3) years parts, two (2) years wearables and one (1) year labor*** from the initial install date. During this period, GREEN SERIES™ will repair or replace defective parts or equipment with new or reconditioned parts at GREEN SERIES™ option, without charge to customer. This limited warranty extends only to the original purchaser and is non-transferable. *(Excluding Indoor Cycling Bikes)*

GREEN SERIES™ Indoor Cycling Bikes warrant this product and its parts against defects in materials or workmanship for ***five (5) years frame, two (2) years parts, one (1) year wearable and no labor*** from the initial install date. During this period, GREEN SERIES™ will repair or replace defective parts or equipment with new or reconditioned parts at GREEN SERIES™ option, without charge to customer. This limited warranty extends only to the original purchaser and is non-transferable

Shipping fees incurred from returns for under-warranty service in the warranty time-line will be paid by GREEN SERIES™. All shipping fees both to and from GREEN SERIES™ following this warranty time-line period must be paid by the customer. All returns, both during and following the warranty time-line period, must be affected via the Procedures for Obtaining Warranty Service described below.

All original parts (parts installed by GREEN SERIES™ at the original system build) replaced by GREEN SERIES™, its authorized service center or authorized service technician, become the property of GREEN SERIES™. Any after-market additions or modifications void all warranties. The original purchaser is responsible for the payment, at current rates, for any service or repair outside the scope of this limited warranty.

GREEN SERIES™ makes no other warranty, expressed or implied, including but not limited to implied warranties of merchantability, fitness for a particular purpose, or conformity to any representation or description, with respect to this warranty other than as set forth below. GREEN SERIES™ makes no warranty or representation, either expressed or implied, with respect to any other manufacturer's product or documentation, its quality, performance, merchantability, fitness for a particular purpose, or conformity to any representation or description.

Except as provided below, GREEN SERIES™ is not liable for any loss, cost, expense, inconvenience or damage that may result from use or inability to use the equipment. Under no circumstances shall GREEN SERIES™ be liable for any loss, cost, expense, inconvenience or damage exceeding the purchase price of the equipment.

The warranty and remedies set forth below are exclusive and in lieu of all others, oral or written, expressed or implied. No reseller, agent or employee is authorized to make any modification, extension or addition to this warranty.

Warranty Conditions and Restrictions

The above Limited Warranty is subject to the following conditions:

1. This warranty extends only to products distributed and/or sold by GREEN SERIES™. It is effective only if the products are purchased and operated in the USA, (Within the USA including US 48 States, Alaska and Hawaii), Puerto Rico, Canada and Mexico. All countries outside the USA for warranty service do not include labor rates.
2. This warranty covers only normal use of the equipment. GREEN SERIES™ shall not be liable under this warranty if any damage or defect results from (i) misuse, abuse, neglect, improper shipping or installation; (ii) disasters such as fire, flood, lightning or improper electric current; or (iii) service or alteration by anyone other than an authorized GREEN SERIES™ representative; (iv) damages incurred through irresponsible use, including those resulting from equipment placed into humid environments, unfinished structures, structures under construction or remodel or placed in an outdoors setting, or other non-recommended practices.
3. GREEN SERIES™ shall not be held liable or responsible for any damages to the units caused during the install of any product.
4. GREEN SERIES™ shall not be held liable or responsible for any structural or cosmetic damages to facilities caused by the placement or operation of any equipment sold and installed by a GREEN SERIES™ authorized service technician or installer.

5. Changes in the cosmetic appearance of components and parts within the unit that do not affect its performance will not be covered by any part of this warranty.
6. Damage due to normal wear and tear as defined by items subject to normal use and/or exposure, consumables, and cosmetic items, including, but not limited to the following: grips, seats, paint scratches, and labels.
7. Travel costs associated with service more than 100 miles or two hours outside the service area of **GREEN SERIES™** service technicians shall be the responsibility of the customer.
8. Any and all shipping damages, visible or hidden, shall be the responsibility of the shipper. Note: Damage caused by common carrier is, by federal law, the carrier's responsibility and must be claimed with the carrier at the time of delivery. The recipient who signed for the equipment is responsible for the filling of the damage claim and notification to **GREEN SERIES™**.
9. The end user of the equipment shall ensure that the facility has proper height, width and length clearances, including ADA requirements, for the product(s) being placed into operation. **GREEN SERIES™** will not be held liable or responsible for the fitment of equipment sold to the customer.
10. Customer must retain bill of sale or other proof of purchase and register equipment within thirty (30) days of installation to receive warranty service. Registration of the equipment ensures **GREEN SERIES™** the ability to provide prompt and complete service.
11. No warranty extension will be granted for any replacement part(s) furnished to the purchaser in fulfillment of this warranty.
12. **GREEN SERIES™** and its Authorized Service Center, dealers or authorized technicians accept no responsibility for any parts of any products returned for repair to **GREEN SERIES™**.
13. **GREEN SERIES™** makes no warranty either expressed or implied regarding third-party (**non-GREEN SERIES™**) installed parts, accessories or modifications.
14. All **GREEN SERIES™** equipment shall be properly cleaned and cared for in accordance to the procedures outlined the in the owner's manual.

Return of Non-Defective Products

A non-defective product may be returned to **GREEN SERIES™** within thirty (30) days of the invoice or installation date for a refund of the original purchase price, not including shipping fees, under the following conditions/fees:

1. **GREEN SERIES™** will refund the cost of equipment only. Customer is responsible for shipping and handling fees incurred to and from the product(s) return.
2. No refund will be granted for equipment which has been opened, used, or tampered with in any way which jeopardizes **GREEN SERIES™** ability to remarket or resell the product. **GREEN SERIES™** maintains full discretion in decisions regarding product returns.
3. Any non-defective returns are subject to a twenty-five percent (25%) restocking fee. This fee will be deducted from the equipment purchase price refund less any shipping or handling charges.

To return a defective product, please contact the selling dealer or Green Series Customer Service Department for a Return Merchandise Authorization (RMA) number and follow the Return of Products Instructions below. The RMA is valid for thirty (30) days from date of issuance. **Returns will not be accepted without an RMA.** Manufacturer restrictions do apply. Any item missing the UPC on the original packaging may not be returned.

Procedures for Obtaining Warranty Service

RMA (Return Merchandise Authorization) Policy:

The customer must obtain an RMA number and provide proof of purchase. RMA and services are rendered by **GREEN SERIES™** only. Any shipping costs after the for-mentioned warranty lengths (starting from the original date of install) on any item returned for repair or replacement is the customers' responsibility. All returned parts and equipment must have an RMA number written clearly on the outside of the package along with a letter detailing the problems and a copy of the original proof of purchase. No COD packages will be accepted. No package will be accepted without a RMA number written on the outside of the package. RMA numbers are only valid for thirty (30) days from the date of issue.

Should you have any problems with your equipment, please follow these procedures to obtain the service:

1. If the equipment must be repaired, contact our Customer Care Department and a **Service Order Number** will be issued by Customer Care for dispatch of an authorized technician.
2. Upon receiving the technician service report, **GREEN SERIES™** will repair or replace your defective parts and will ship replacement parts to the location specified (dependent on parts availability) via UPS.
3. **GREEN SERIES™** will pay for shipping to and from the customer only within the time allocated under the warranty time-line following the original product installation date. Following this period all shipping fees for post warranty repairs are the sole responsibility of the customer. The customer also assumes full liability for losses or damages resulting from shipping as well as all responsibility to pursue remuneration for such issues with their selected carrier.

After Warranty – Post Warranty Repair

For post warranty repair, the procedure is the same as outlined above for service and shipping. However, customer is responsible for shipping charges both ways, labor, trip charges and the current price of part(s) needed to repair the product(s).

WARRANTY EXCLUSIONS

GREEN SERIES™ does not offer technical support for any product or parts installed by other manufacturers. Technical support should be pursued through channels offered by the equipment's individual technician support. **GREEN SERIES™** accepts no liability for problems caused by after-market hardware modifications or additions. **GREEN SERIES™** is not responsible for giving any technical support concerning the installation or integration of any component the customer did not pay **GREEN SERIES™** to install. **GREEN SERIES™** is not responsible for loss of time, even with hardware failure. **GREEN SERIES™** is not responsible for any loss of work ("down time") caused by a product requiring service. This warranty is null and void if the defect or malfunction was due to damage resulting from operation not within manufacturer specifications. It will also be null and void if there are indications of misuse and/or abuse. **GREEN SERIES™** has the option of voiding the warranty if anyone other than a **GREEN SERIES™** authorized technician attempts to service the product. **GREEN SERIES™** will not warrant any problems arising from an act of God (lighting, flooding, tornado, etc.), electrical spikes or surges, or problems arising out of hardware or additional devices added to complement any system/component bought at **GREEN SERIES™**. Under no circumstances will **GREEN SERIES™** be responsible for any refund or remuneration exceeding the original purchase price of the product less any shipping fees. **GREEN SERIES™** will not be held responsible for typographical errors on sales receipts, repair tickets, or on our websites. **GREEN SERIES™** makes every effort to ensure all information on our websites, owner's manuals, marketing and other published materials is accurate.

- **By using this product, I indicate that I understand and agree to the terms of this warranty.**

