

FRENCH FITNESS

FF-X7LP

**FRENCH FITNESS X7LP
MULTI HOME GYM W/LEG PRESS**

ASSEMBLY MANUAL



EXERCISES

Main Station (Standard)

- (1) Seated Row
- (2) Chest Press
- (3) Shoulder Press
- (4) Pec Fly
- (5) Lat Pulldown
- (6) Ab Crunch
- (7) Tricep Pushdown
- (8) Bent Over Row
- (9) Upright Rows
- (10) Standing Bicep Curl
- (11) Shoulder Shrugs
- (12) Leg Extensions

- (13) Standing Leg Curls
- (14) One Arm Tricep Kickbacks
- (15) One Arm Lat Raise
- (16) One Arm Rear Delt
- (17) One Arm Bicep Curls
- (18) One Leg Lateral Raises (Inner & Outer Thigh)
- (19) One Leg Extension
- (20) One Leg Curls

Leg Press Station (Standard)

- (1) Leg Press
- (2) Calf Raises

FEATURES

- Steel Tube: Q235
- Pulley: Nylon, 4.2 in x .8 in (106 x 20 mm), with sealed bearing 6202RS, more durable than cast iron and protect cable
- Cable: Steel cable .13 in (3.5 mm) jacketed with PVC .21 in (5.5 mm) outside diameter
- Powder Coating: 2 rounds
- Stuffing: PU foam with synthetic leather

ACCESSORIES INCLUDED

- (1) Lat Pulldown Bar
- (2) Straight Bar
- (3) Steel Locks
- (4) Carabiners
- (5) Strap Handles
- (6) Extension Chains
- (7) Foot Plate (for Seated Rows)

TECH SPECS

- Weight Stack: 220 lb (100 kg)
- Leg Press: 1:1 Ratio (Includes Weight Horns to add weight plates)
- Weight: 518 lb (235 kg)
- Dimensions (L x W x H): 72" x 79" x 81" (1820 mm x 2000 mm x 2050 mm)
- Steel Tube Size (Core of Machine): 50mm x 100mm x 2.5mm (12 Gauge) - See Image Below for Exact Tubing

WARRANTY

10 Years Parts, 1 Year Labor (Light Commercial)

1. IMPORTANT SAFETY INSTRUCTIONS

WARNING - Read all instructions before using this machine.

- Install the product on a flat level surface
- Place your unit on a solid, level surface when in use
- Never allow children on or near the machine.
- Keep hands away from all moving parts.
- Never drop or insert any object into any openings.
- Care must be taken when lifting or moving the equipment so as not to injure your back. Always use proper lifting techniques and/or seek assistance if necessary.
- Keep children and pets away from the machine at all times. **DO NOT** leave children unattended in the same room with the machine.
- Only 1 person at a time should use the machine.
- If the user experiences dizziness, nausea, chest pain, or any other abnormal symptoms, **STOP** the workout at once. **CONSULT A PHYSICIAN IMMEDIATELY**
- Do not use the machine near water or outdoors.
- Keep hands away from all moving parts.
- Always wear appropriate workout clothing when exercising. **DO NOT** wear robes or other clothing that could become caught in the machine. Running or aerobic shoes are also required when using the machine.
- Use the machine only for its intended use as described in this manual. **DO NOT** use attachments not recommended by the manufacturer.
- Do not place any sharp objects around the machine.
- Disabled person should not use the machine without a qualified person or physician in attendance.
- Never operate the machine if the machine is not functioning properly. A spotter is recommended during exercise.







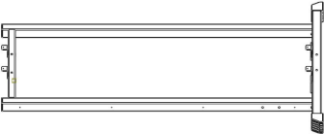
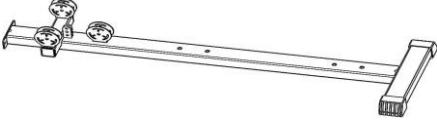
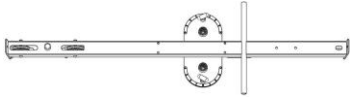
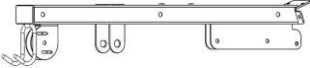
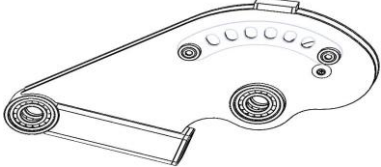
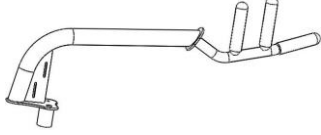
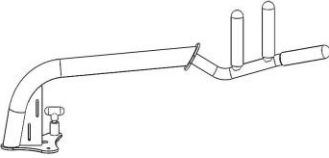

2. CARE INSTRUCTIONS

- Lubricate moving joints with silicon spray after periods of usage.
- Be careful not to damage plastic or metal parts of the machine with heavy or sharp objects.
- The machine can be kept clean by wiping it down using dry cloth.
- Check and adjust the tension of wire rope on a regular basis.
- Regularly check all moving parts and make sure there are signs of wear and damage, if any the use of the device must be stopped immediately and contact our after-sales department.
- During inspection, it is necessary to make sure that all bolts and nuts are completely fixed. If any bolt or nut connection is loosened, please re-tighten.
- Check weld for cracks.
- Failure to perform daily maintenance may result in personal injury or equipment damage.

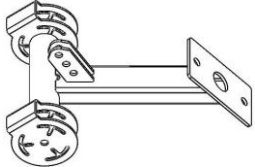
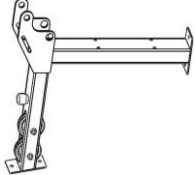
TABLE OF CONTENTS

PARTS LIST-1 (INDIVIDUAL PACKAGING).....	5
PARTS LIST-2 (ASSEMBLY PARTS)	7
BLISTER PACK SCREW LIST	9
ASSEMBLY STEPS	10
PACKAGE SPECIFICATION	41
PACKING LIST	42
PACKING STEPS	45

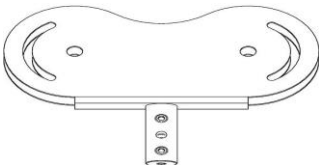
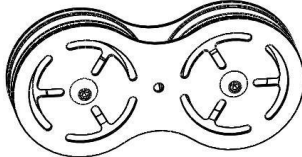

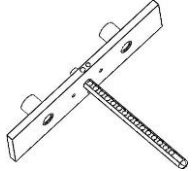
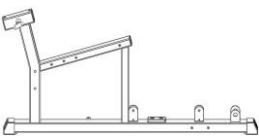
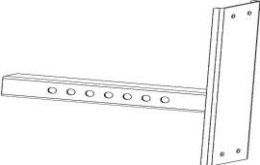
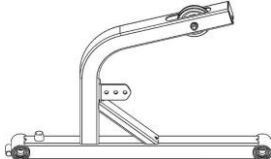



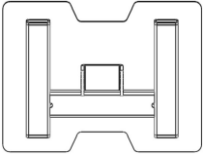
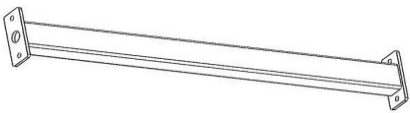
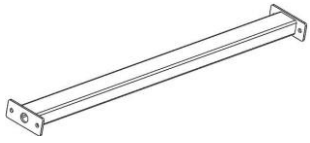
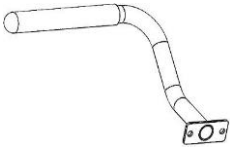
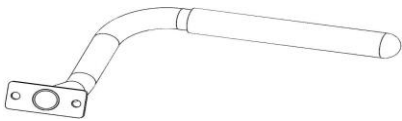



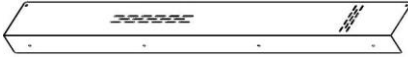
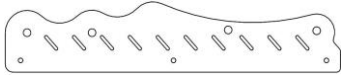
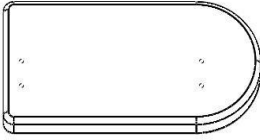
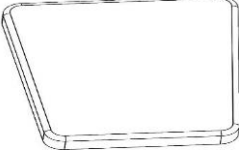

PARTS LIST-1 (INDIVIDUAL PACKAGING)

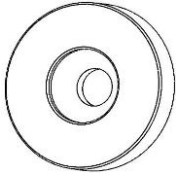
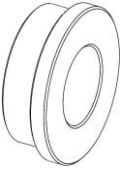
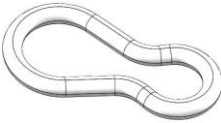
		
NO 1 Small door welding group *1pcs	NO 2 Base components*1pcs	NO 3 Inclined column welding group *1pcs
		
NO 4 Upper oblique welding group *1pcs	NO 5 Turntable assembly*1pcs	NO 6 Boom right assembly*1 pcs
		
NO 7 Boom left assembly*1pcs	NO 8 Cable boom welding group*2pcs	NO 9 Guide component *1pc
		
NO 10 Bracket component *1pcs	NO 11 Leg arm assembly *1pcs	NO 12 Short foam rod set *1pcs
		
NO 13 Long foam rod set *1pcs	NO 14 Double hanging pulley assembly*1pcs	NO 15 Pulley combination * 2 pcs
		
NO 16 High tensile welding group *1pcs	NO 17 Low-stretch welding group *1pcs	NO 18 Counterweight component *1pcs
		
NO 60 Leg press welding group*1pcs	NO 61 Backrest*1pcs	NO 62 Leg press boom welding group*1pcs



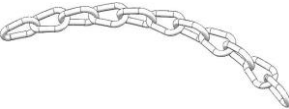
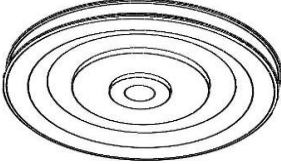

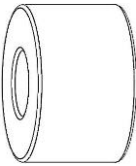

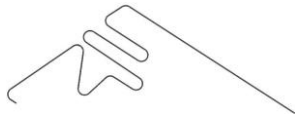

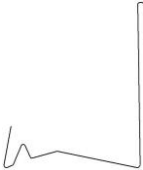
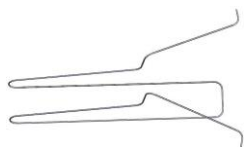
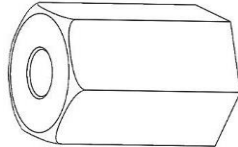
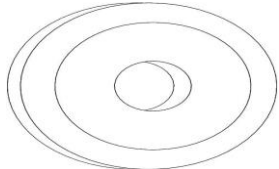
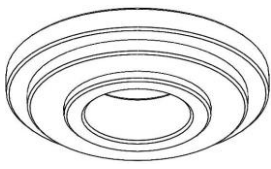

PARTS LIST-1 (INDIVIDUAL PACKAGING)

					
NO 63	Foot pedal assembly*1pcs	NO 64	Upper connection component *1pcs	NO 65	Lower connection component *1pcs
					
NO 66	Right handle assembly *1pcs	NO 67	Left hand handle assembly *1pcs		

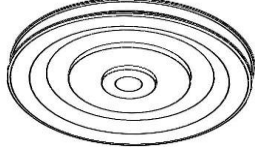
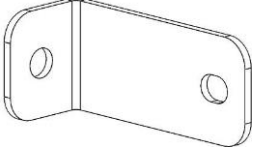





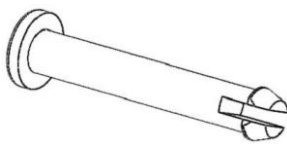
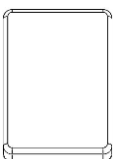
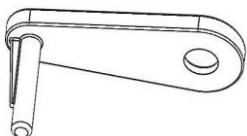







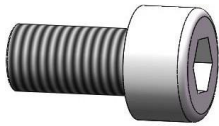
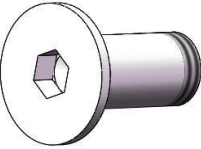

PARTS LIST-2 (ASSEMBLY PARTS)

		
NO 19 Left guard plate*1 pcs	NO 20 Right guard plate*1 pc	NO 21 Upper guard * 2 pcs
		
NO 22 Backrest*2pcs	NO 23 Seat cushion*1 pcs	NO 24 Foam roller *6 pcs
		
NO 25 Foam bucket inner lid*6 pcs	NO 26 Foam barrel outer cover*6 pcs	NO 27 Aluminum alloy end cover*2pcs
		
NO 28 Nylon spacer*2 pcs	NO 29 Standard safety hook * 4 pcs	NO 30 Low pull handle*2 pcs
		
NO 31 Wire rope joint * 4 pcs	NO 32 Small door optical axis * 2pcs	NO 33 Counterweight bolt *1pcs
		
NO 34 Chain 0.35m*3 pcs	NO 35 $\Phi 80$ Pulley*1pcs	NO 36 Rotating shaft*2 pcs
		
NO 37 Weight piece rubber sleeve * 2 pcs	NO 38 Long weight stack * 15 pcs	NO 39 Wire rope (large and small head) *1pcs

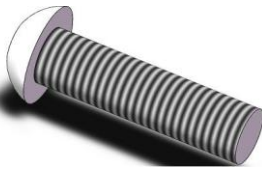
PARTS LIST-2 (ASSEMBLY PARTS)

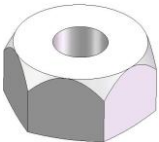
					
NO 40	Wire rope (small, flat head) *1pcs	NO 41	Wire rope (single flat head) *1pcs	NO 42	Wire rope (double small head) *1pcs
					
NO 43	Tie line fixing sleeve*1pcs	NO 44	Gasket*10 pcs	NO 45	Upper nylon sleeve * 8pcs
					
NO 46	Joint shaft *1pcs	NO 47	Blister pack*1pcs	NO 48	Manual *1pcs
					
NO 49	Optical axis fixing plate*1pcs	NO 50	Φ90Pully*28 pcs	NO 51	Cushion connecting plate * 4pcs
					
NO 52	Assemble lock plate 140*50*1pcs	NO 53	Assemble lock plate120*50*4pcs	NO 54	Assemble lock plate 150*40*1pcs
					
NO 55	Pully limit sleeve * 2 pcs	NO 56	Training image *1pcs	NO 57	Bayonet rope*6 pcs
					
NO 58	Cushion*1pcs	NO 59	Pully rope sleeve*1pcs		

BLISTER PACK SCREW LIST

					
A	Hexagon socket flat head screws M10*115*3pcs	B	Hexagon socket flat head screws M10*100*1pcs	C	Hexagon socket flat head screws M10*95*6pcs
					
D	Hexagon socket flat head screws M10*55*2pcs	E	Hexagon socket flat head screws M10*65*2pcs	F	Hexagon socket flat head screws M10*45*16pcs
					
G	Hexagon socket flat head screws M10*30*9pcs	H	Hexagon socket flat head screws	I	Hexagon socket head screw M5*10*12pcs
					
J	M10*20 hexagon socket flat countersunk head screws*2pcs	K	Hexagon socket flat head screw M8*70*8pcs	L	Hexagon socket flat head screw M8*25*8pcs
					
M	Ø10 flat gasket 40pcs	N	M10 lock nut*40pcs	T	Hexagon socket flat head screw M10*80*2*8pcs
					
X	Hexagon socket flat head screw M10*60*2pcs	Q	Hexagon socket flat head screw M10*50*1pcs		

ASSEMBLY STEPS 1

Item NO	Name	Quantity	Item NO	Name	Quantity
NO 1	Small door welding group	1	NO 3	Inclined column welding group	1
NO 2	Base components	1	NO 4	Incline welding group	1
C	M10*95 Hexagon socket flat head screw	2	D	M10*55 Hexagon socket flat head screws	2
M	Ø10Flat gasket	6	N	M10 Locknut	6
H	M10*20 Hexagon socket flat head screw	4	T	M10*80 Hexagon socket flat head screws	2
NO 52	Assemble the lock plate	1	NO 54	Assemble the lock plate	1

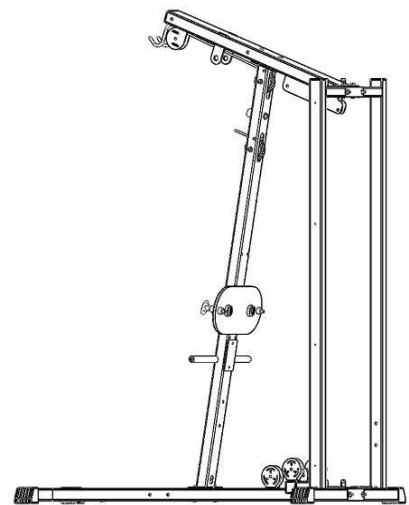
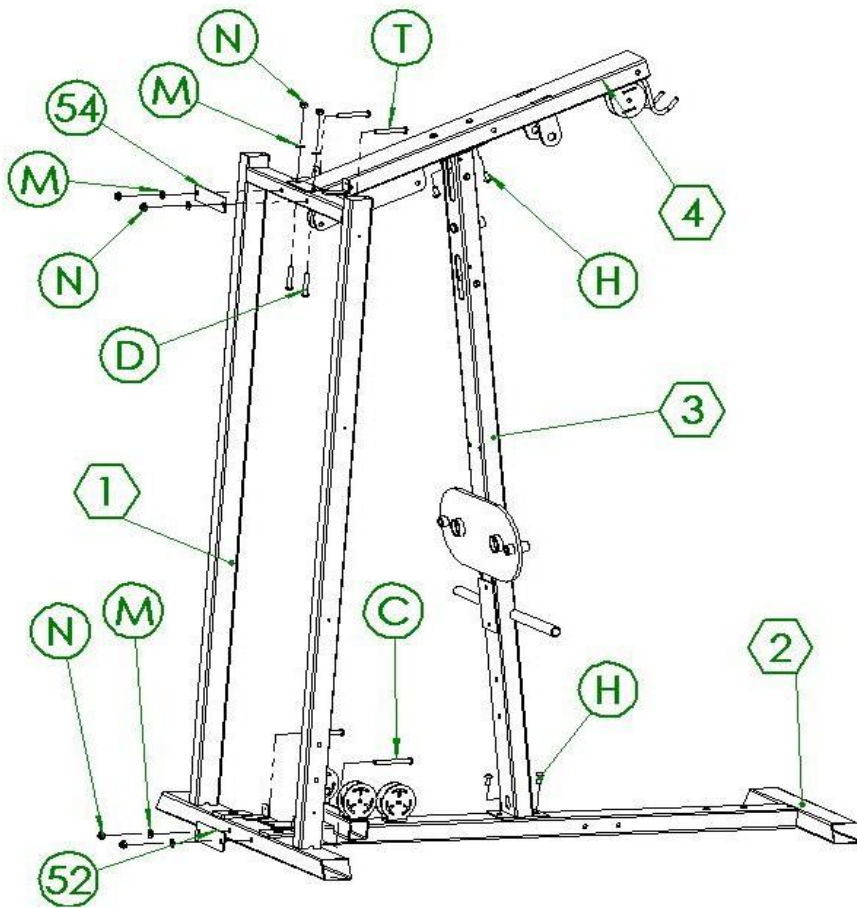

No.1 Small door welding group *1pcs

Step NO	Item NO	Name	Quantity	Item NO	Name	Quantity
	NO 75	40*60 Square tube stopper	2			
	NO 76	50*75 Foot cover	2			
	S	M10 Blind rivet screws	2			

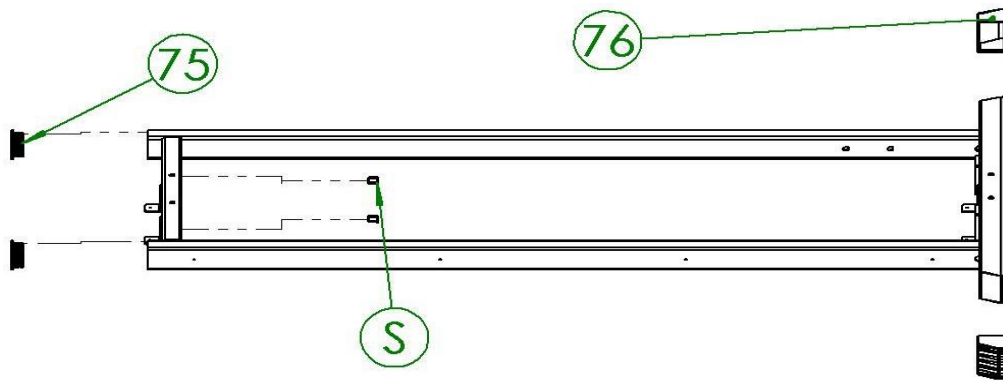

No.4 Upper oblique welding group *1pcs

Step NO	Item NO	Name	Quantity	Item NO	Name	Quantity
	NO 77	100*50 Square tube stopper	1			

The two pins need to be buckled here

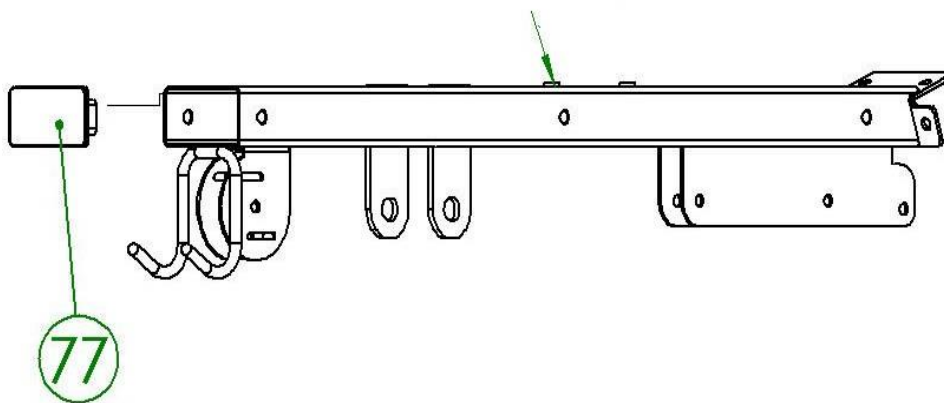

No.2 Bottom welding group *1pcs

Step NO	Item NO	Name	Quantity	Item NO	Name	Quantity
	NO 78	50*50 Square tube stopper	2			
	NO 76	50*75 Foot cover	2			

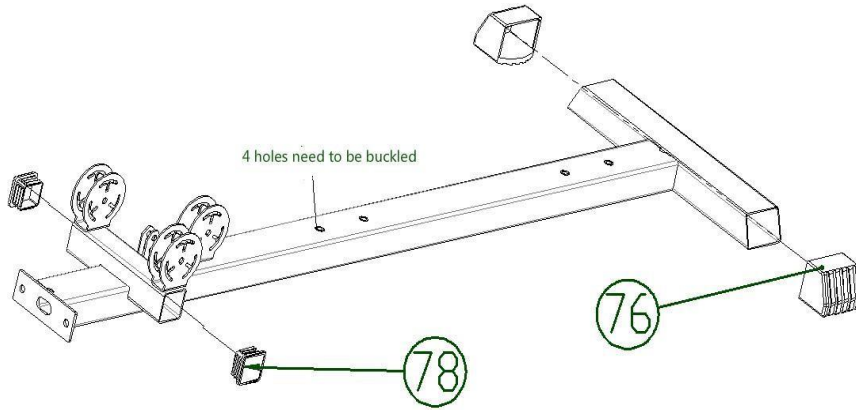

No.3 oblique column welding group *1pcs

Step NO	Item NO	Name	Quantity	Item NO	Name	Quantity
	NO 79	Scale mark	2	NO 84	Pin	2
	NO 80	Limit rubber sleeve	1	NO 85	61904 Ball bearing	4
	NO 81	Pulley spacer	4	Y	M6 Hex nuts	2
	P	M6*85 Cylinder head screws	2	NO 50	Pully	2
	W	M10*85 Flat round head screws	2	M	Ø10 Flat gasket	2
	NO 82	Star nut M8 black	2	N	M10 Locknut	2
	NO 83	T-bolt M8	2			

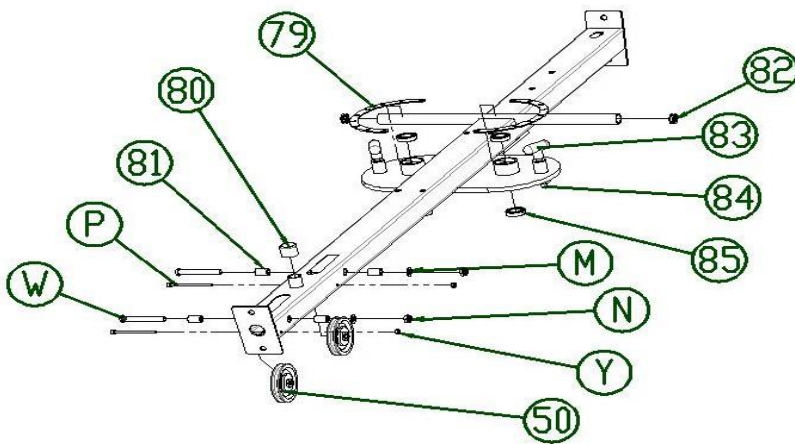

ASSEMBLY STEPS 2

Item NO	Name	Quantity	Item NO	Name	Quantity
NO 5	Turntable assembly	1	NO 45	Upper nylon spacer	2
NO 10	Bracket assembly	1	H	M10*20 Hexagon socket flat head screws	4
NO 36	Upper shaft	1	M	Ø10 Flat gasket	2
NO 44	Gasket	2	N	M10 Locknut	2
			E	M10*65 Hexagon socket flat head screws	2

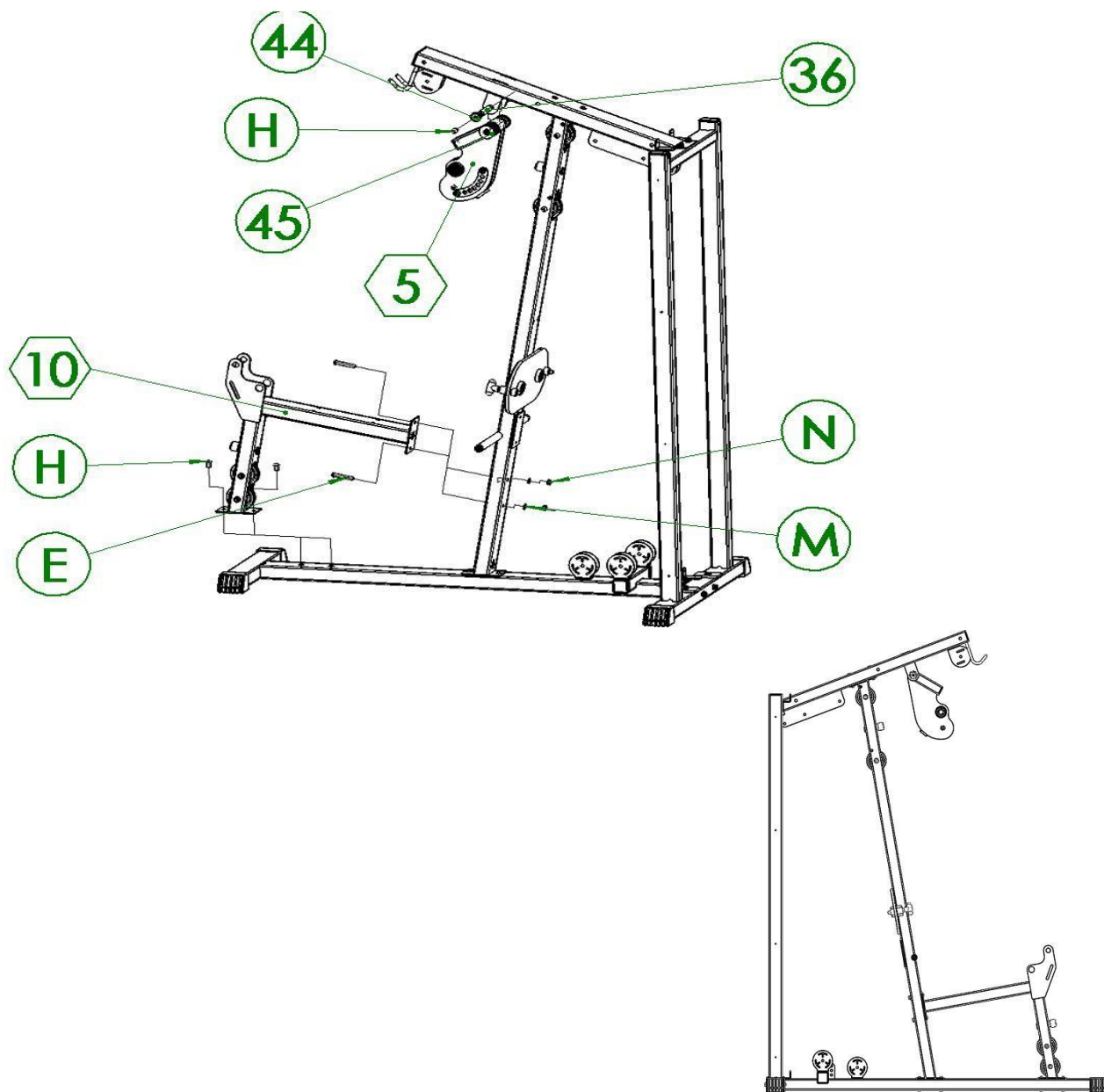

No.5 Turntable assembly * 1pcs

Step NO	Item NO	Name	Quantity	Item NO	Name	Quantity
	NO 75	40*60 Square tube stopper	1	Z	M8*10 Hexagon socket head screw	2
	NO 87	Stainless steel adjusting plate	1			
	NO 88	6004 BearingØ42*Ø20	4			
	NO 89	Limit sleeve column	2			

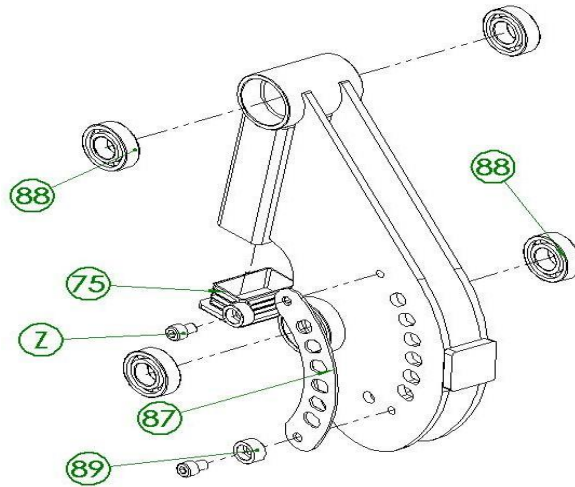

No.10 Bracket assembly * 1pcs

Step NO	Item NO	Name	Quantity	Item NO	Name	Quantity
	NO 90	50*75 Square tube stopper	1	W	M10*85 Hexagon socket flat head screws	2
	NO 80	Limit rubber sleeve	1	M	Ø10 Flat gasket	2
	NO 50	Pully	2	N	M10 Locknut	2
	NO 81	Pulley spacer	4			

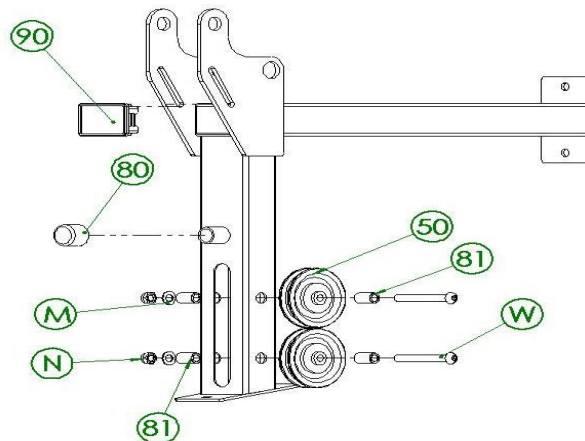

ASSEMBLY STEPS 3

Item NO	Name	Quantity	Item NO	Name	Quantity
NO 44	Gasket	2	NO 36	Upper shaft	1
NO 55	Upper nylon spacer	2	NO 7	Boom left assembly	1
NO 6	Boom right assembly	1	J	M10*20 Hexagon socket flat head screws	2
NO 8	Boom combination	2	H	M10*20 Hexagon socket countersunk head screws	2
NO 27	Aluminum alloy end cap	2	N	M10 Locknut	1
M	Ø10 Flat gasket	1	B	M10*100 Hexagon socket flat head screws	1

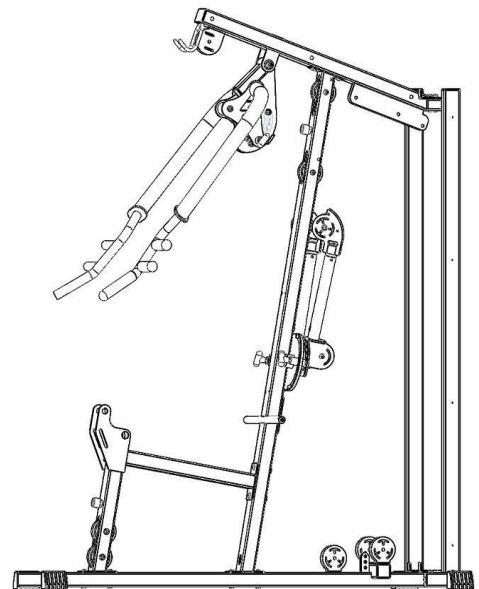
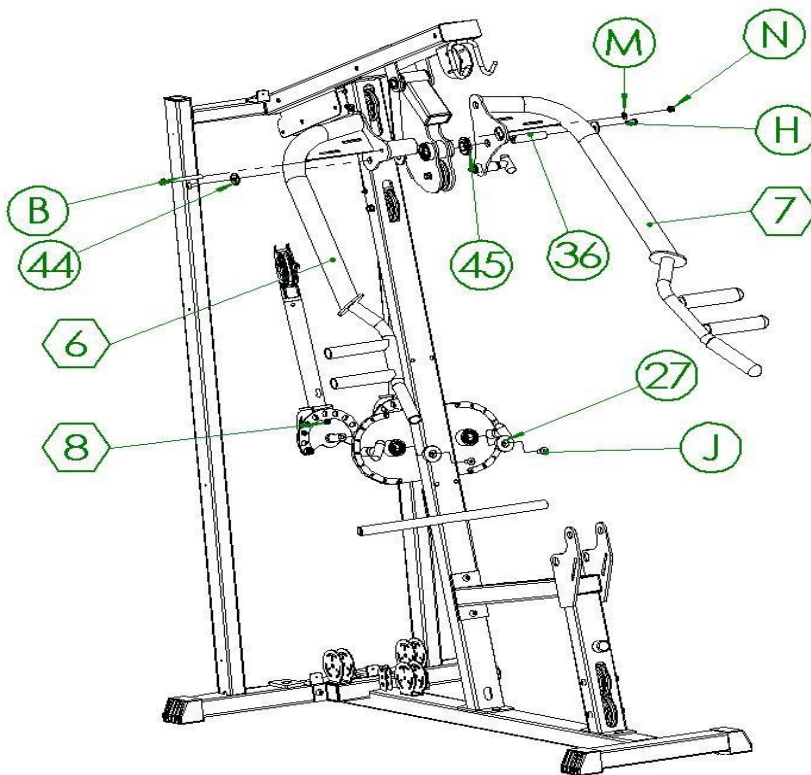

No.6 Boom assembly
right *1pcs

Step NO	Item NO	Name	Quantity	Item NO	Name	Quantity
	NO 86	Tube Ø30*160	3			

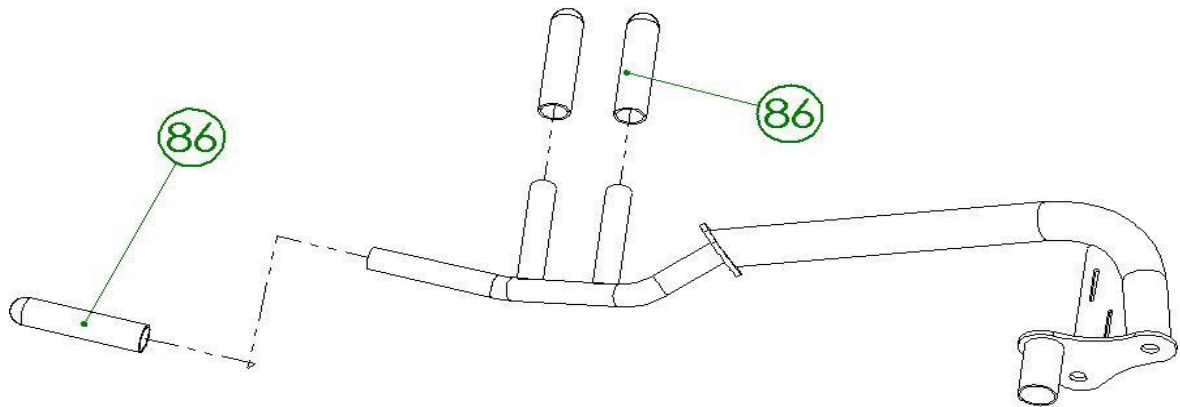

No.7 Boom assembly
left *1pcs

Step NO	Item NO	Name	Quantity	Item NO	Name	Quantity
	NO 83	T Pin M8	1			
	NO 86	Tube Ø30*160	3			
	NO 84	Pin	1			

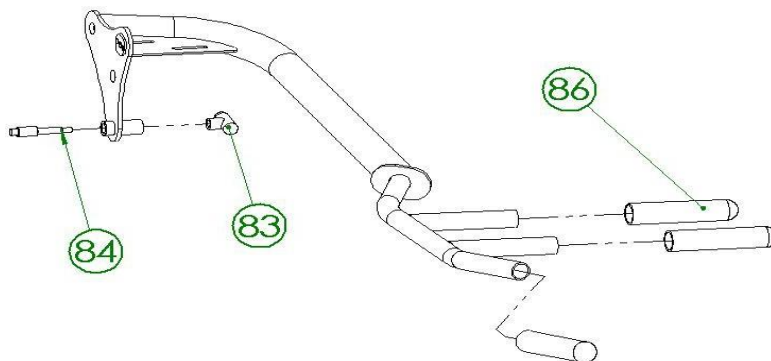

No.8 Boom assembly/2pcs

Step NO	Item NO	Name	Quantity	Item NO	Name	Quantity
	NO 89	Limit sleeve column	2	Z	M8*10 Cylinder head hexagon screw	3
	NO 91	Large stainless steel adjustment	1	F	M10*45 Hexagon socket flat head screws	1
	NO 50	Pully	1	N	M10 Locknut	1
	NO 92	Cable arrow mark	1	M	Ø10 Flat gasket	1
	NO 57	Clamp pin	1			

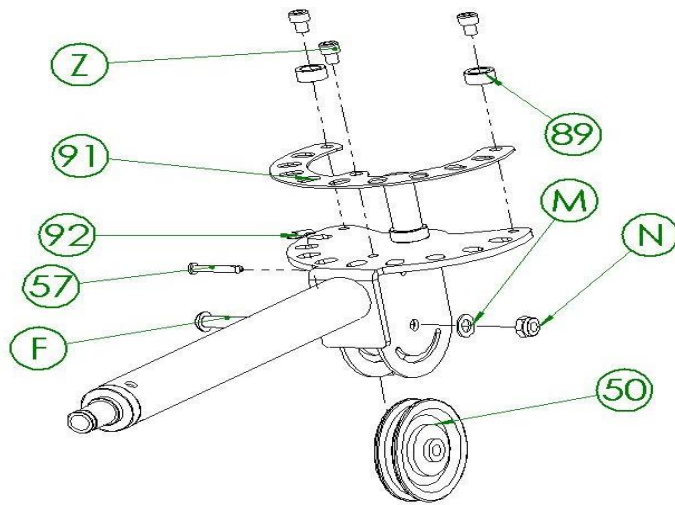

No.8 Boom assembly/2pcs

Step NO	Item NO	Name	Quantity	Item NO	Name	Quantity
	NO 50	Pully	1	F	M10*45 Hexagon socket flat head screws	1
	NO 93	61804 Bearing Ø32*Ø20	2	N	M10 Locknut	1
	NO 94	Circlip for shaft	1			
	M	Ø10 Flat gasket	1			

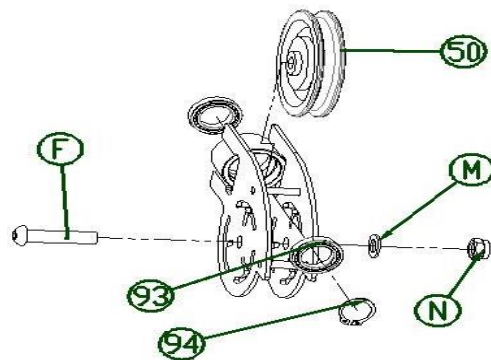

ASSEMBLY STEPS 4

Item NO	Name	Quantity	Item NO	Name	Quantity
NO 49	Optical axis fixing plate	1	NO 9	Guide components	1
NO 32	Small door optical axis	2	H	M10*20 Hexagon socket flat head screws	2
NO 37	Rubber mat	2	G	M10*30 Hexagon socket flat head screws	2
NO 18	Weight stack components	1			

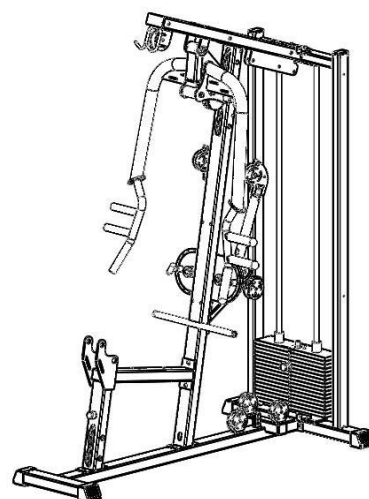
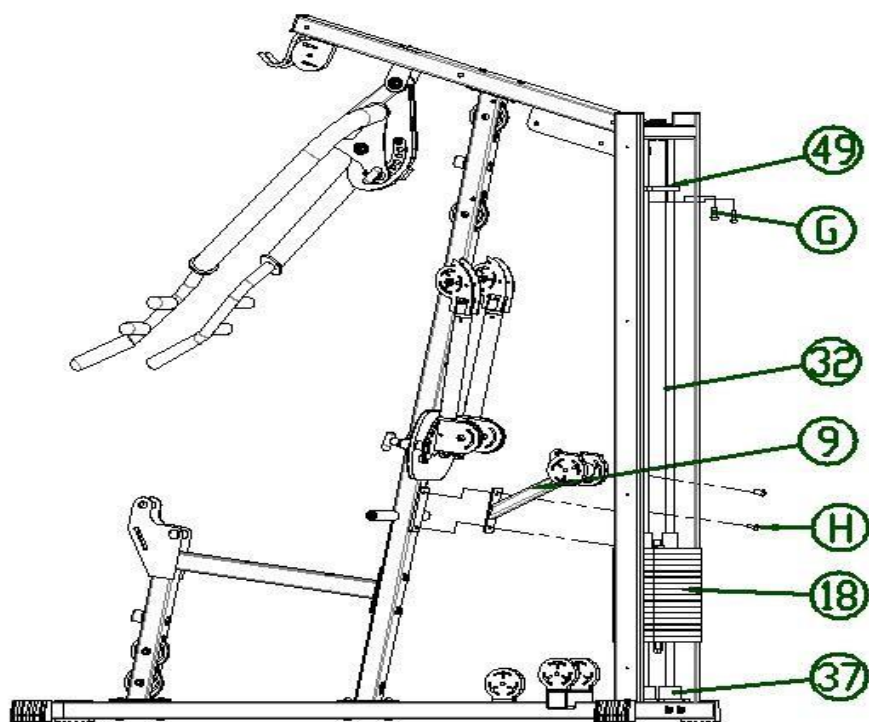

No.18 Weight stack component/1 pcs

Step NO	Item NO	Name	Quantity	Item NO	Name	Quantity
	NO 95	Weight stack sleeve	2	V	M10 Screws	1
	o	M18*1.5 Lock nut	1			
	NO 97	Weight stack headpiece	1			
	NO 96	Weight lever	1			

Tools/equipment

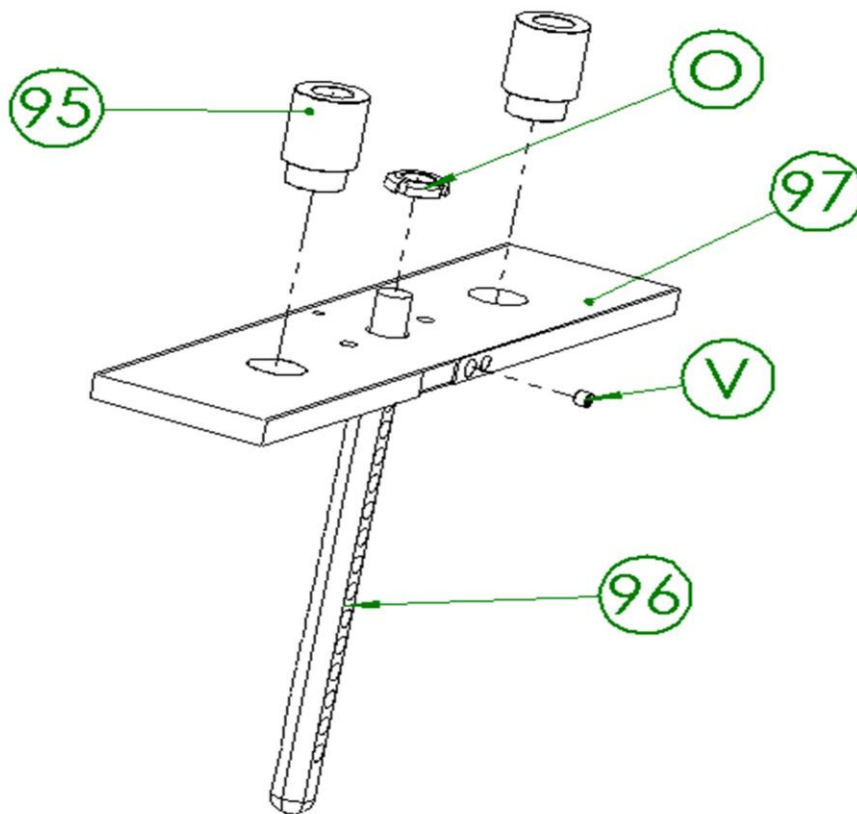

ASSEMBLY STEPS 5

Item NO	Name	Quantity	Item NO	Name	Quantity
NO 44	Gasket	2	H	M10*20 Hexagon socket flat head screws	2
NO 46	Joint axis	1			
NO 11	Leg arm assembly	1			

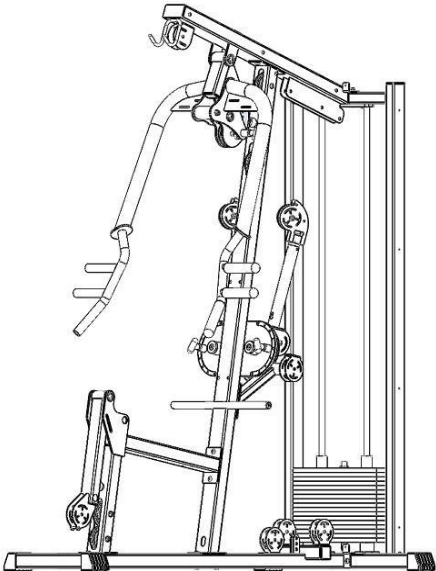
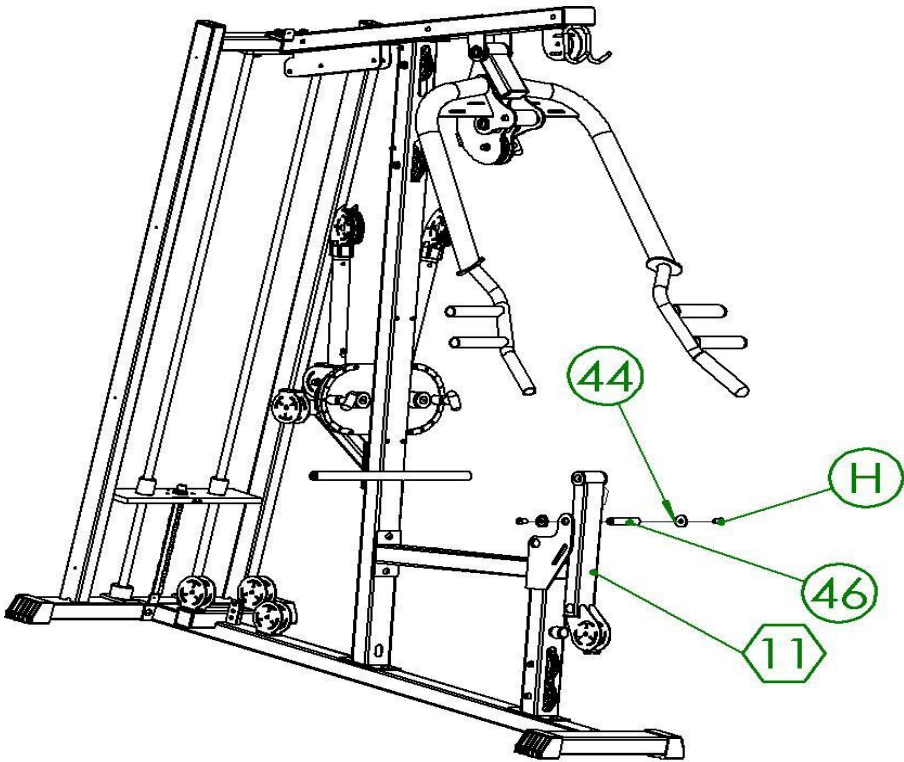

No.11 Leg arm assembly * 1pcs

Step NO	Item NO	Name	Quantity	Item NO	Name	Quantity
	NO 28	Nylon sleeve	2			

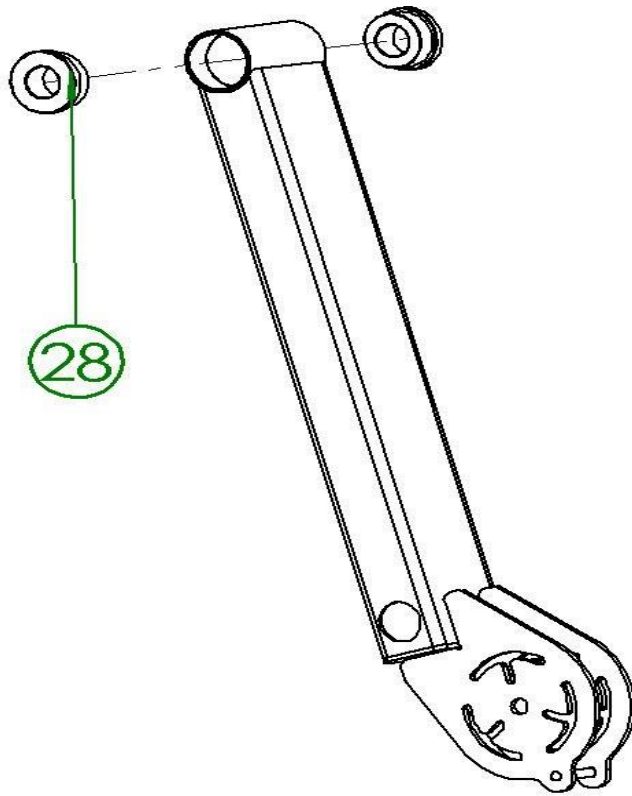

ASSEMBLY STEPS 6

Item NO	Name	Quantity	Item NO	Name	Quantity
NO 19	Left guard plate	1			
NO 20	Right guard plate	1			
I	M5*10 Hexagon socket head screw	12			

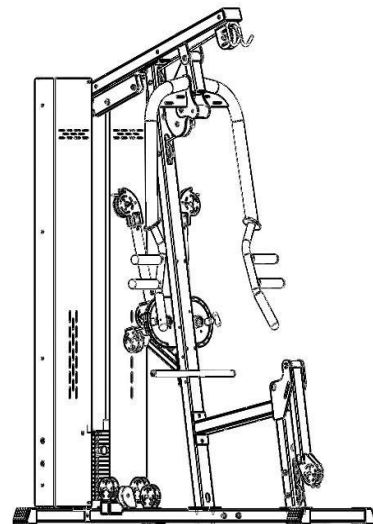
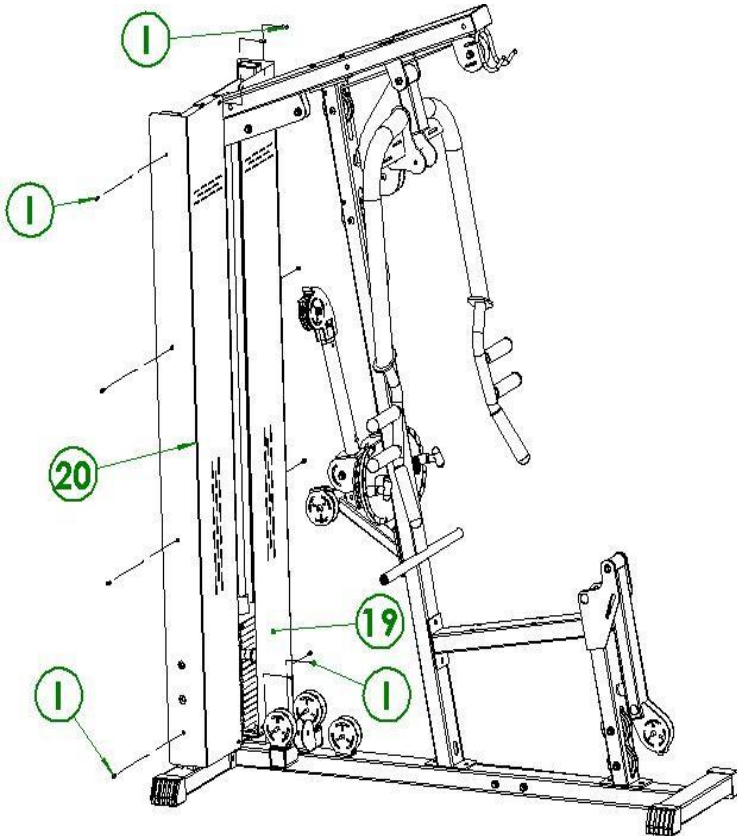

Do not tighten the screws on the guard plate

ASSEMBLY STEPS 7

Item NO	Name	Quantity	Item NO	Name	Quantity
NO 64	Upper connection components	1	C	M10*95 Hexagon socket flat head screws	4
NO 65	Lower connection components	1	N	M10 Locknut	8
NO 53	Assemble the lock plate	4	T	M10*80 Hexagon socket flat head screws	2
NO 60	Leg press welding group	1	X	M10*60 Hexagon socket flat head screws	2
M	Ø10 Flat gasket	8			

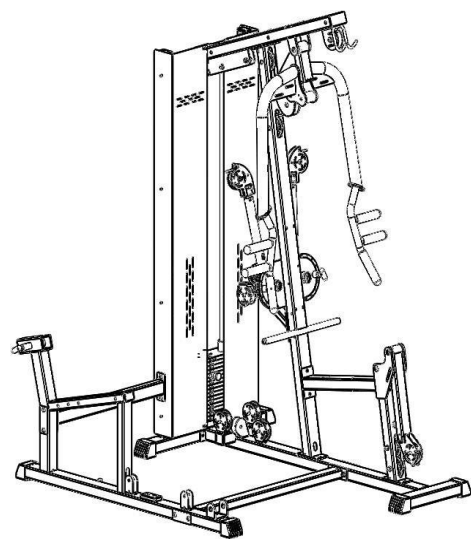
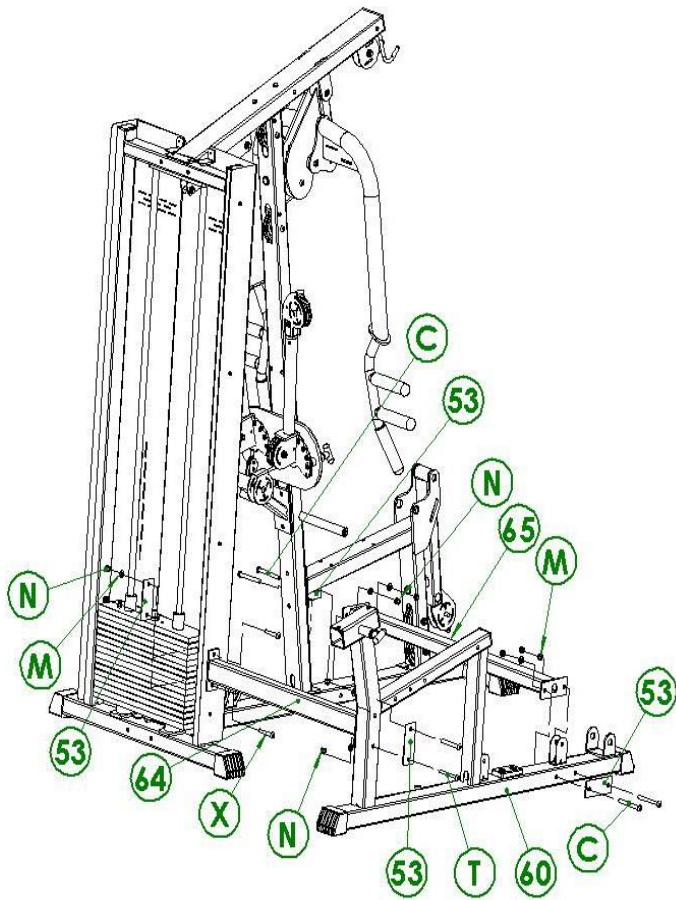

No.60 Leg press frame welding group*1pcs

Step NO	Item NO	Name	Quantity	Item NO	Name	Quantity
	NO 99	60 turn to50	2	NO 75	40*60 Tube stopper	1
	NO 98	shock absorption pad	1	H	M10*20 Hexagon socket flat head screws	2
	NO 84	Pin	1	S	M10 Blind rivet nut	2
	NO 76	50*75 Foot cover	2	NO 83	M8 T-pin	1

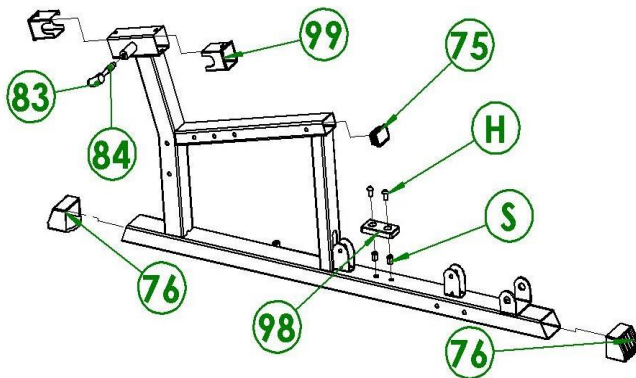

No.66 Right-hand handle assembly*1pcs

Step NO	Item NO	Name	Quantity	Item NO	Name	Quantity
	NO 100	Blind tube Ø30*240	1			

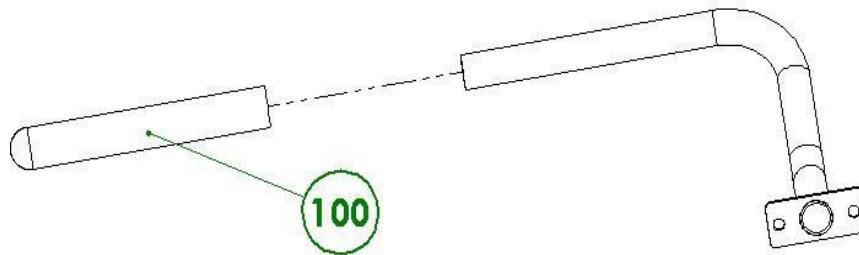

ASSEMBLY STEPS 8

Item NO	Name	Quantity	Item NO	Name	Quantity
NO 61	Backrest board assembly	1	NO 36	Upper shaft	1
NO 62	Leg kick boom welding group	1	H	M10*20 Hexagon socket flat head screws	2
NO 66	Right handle assembly	1	T	M10*80 Hexagon socket flat head screws	2
NO 67	Left handle assembly	1	M	Ø10 Flat gasket	2
NO 44	Gasket	2	N	M10 Locknut	2
NO 45	Upper nylon sleeve	2			

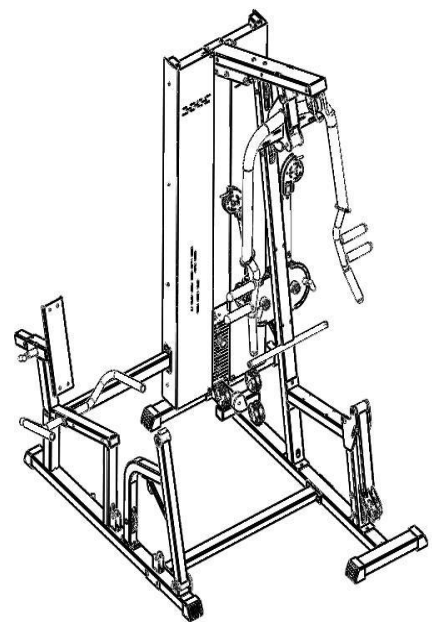
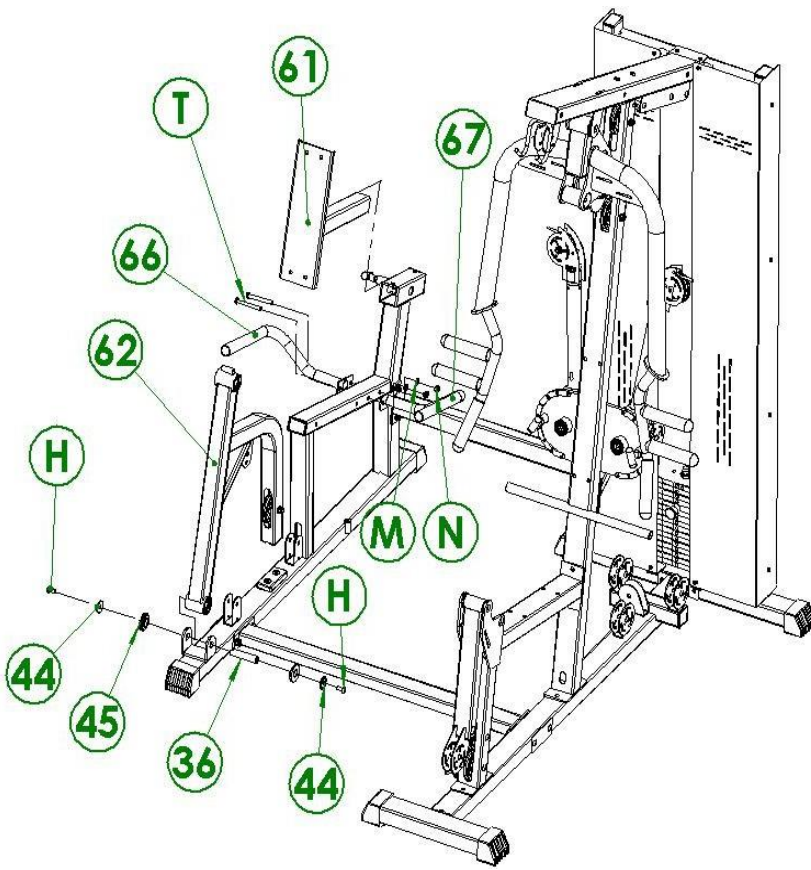

No.67 Left hand handle assembly

Step NO	Item NO	Name	Quantity	Item NO	Name	Quantity
	NO 100	Blind tube Ø30*240	1			

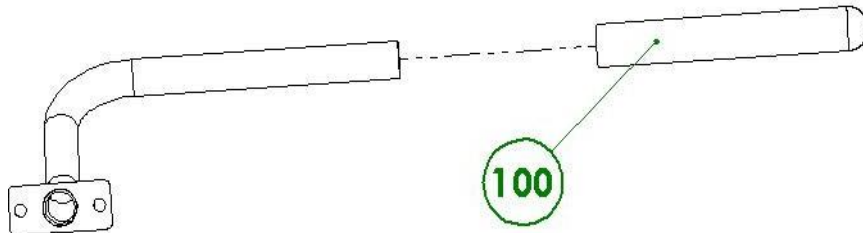

No.62 Leg press boom welding group

Step NO	Item NO	Name	Quantity	Item NO	Name	Quantity
	NO 88	6004 BearingØ42*Ø20	4	S	M10 Blind rivet nut	1
	NO 55	Pulley limit sleeve	2	M	Ø10 Flat gasket	1
	NO 50	90 Pully	1	N	M10 Locknut	1
	NO 101	Damping positioning block	1			

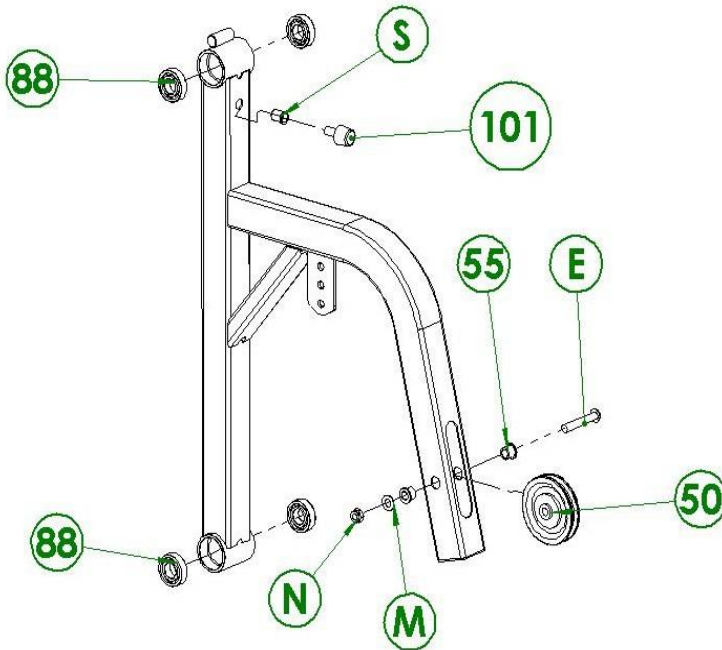

ASSEMBLY STEPS 9

Item NO	Name	Quantity	Item NO	Name	Quantity
NO 63	Step components	1	NO 36	Upper shaft	1
NO 44	Gasket	2	N	M10 Locknut	2
NO 22	Backrest	1	Q	M8*25 Hexagon socket flat head screws	4
NO 45	Upper nylon spacer	2	M	Ø10 Flat gasket	2
NO 51	Cushion connecting plate	4	T	M10*80 Hexagon socket flat head screws	2

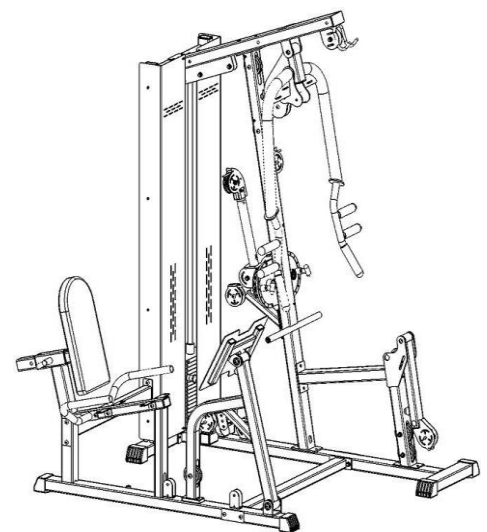
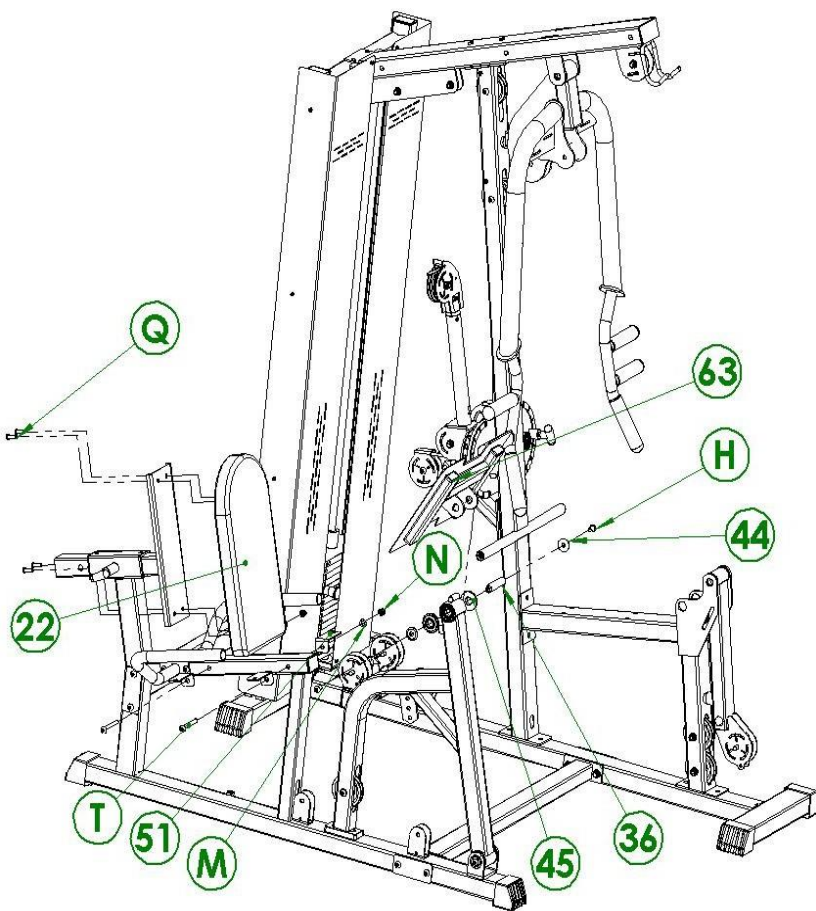

ASSEMBLY STEPS 10

Item NO	Name	Quantity	Item NO	Name	Quantity
NO 23	Seat cushion	1			
Q	Hexagon socket flat head screw M8*25	4			

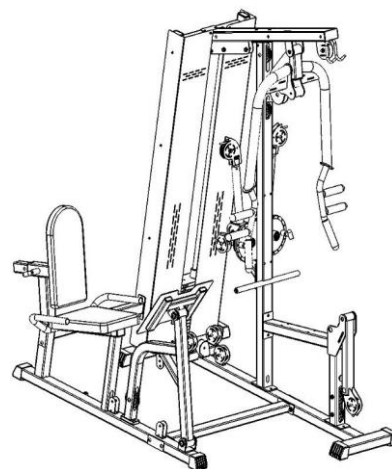
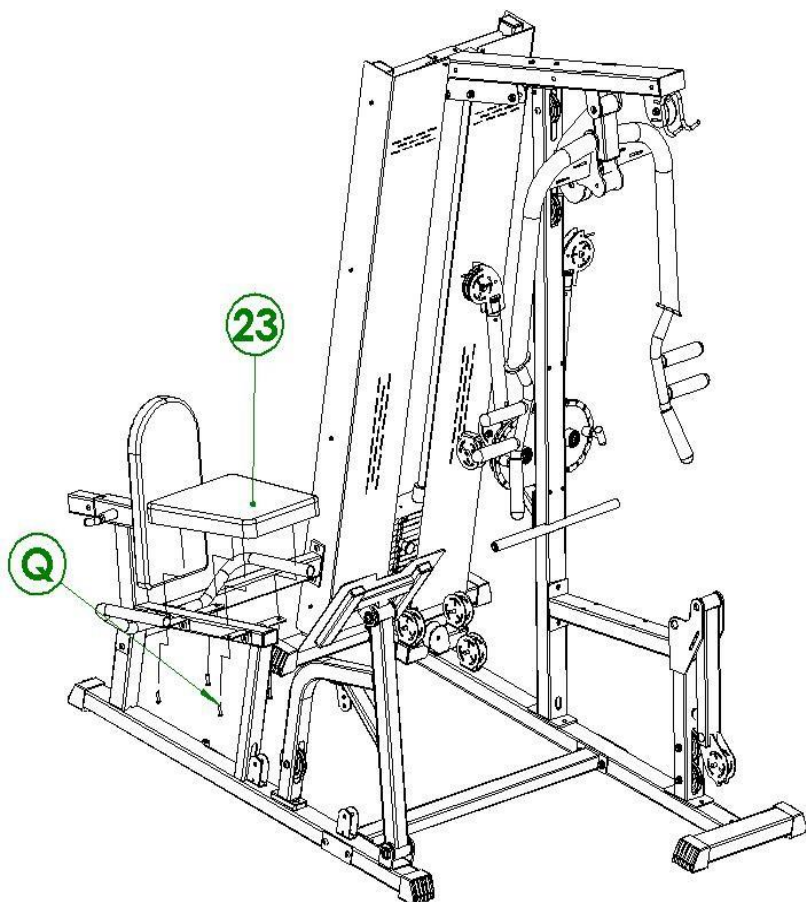

ASSEMBLY STEPS 11

Item NO	Name	Quantity	Item NO	Name	Quantity
NO 22	Backrest	1			
NO 58	Cushion	1			
K	Hexagon socket flat head screw M8*70	8			

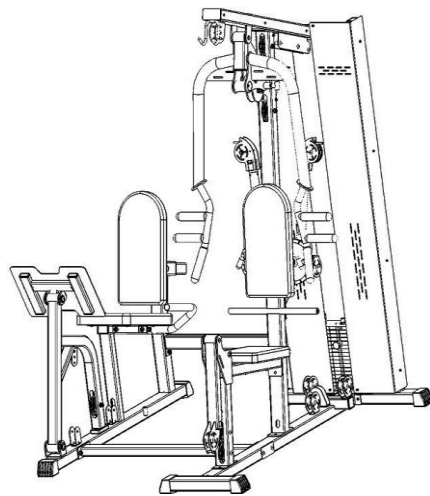
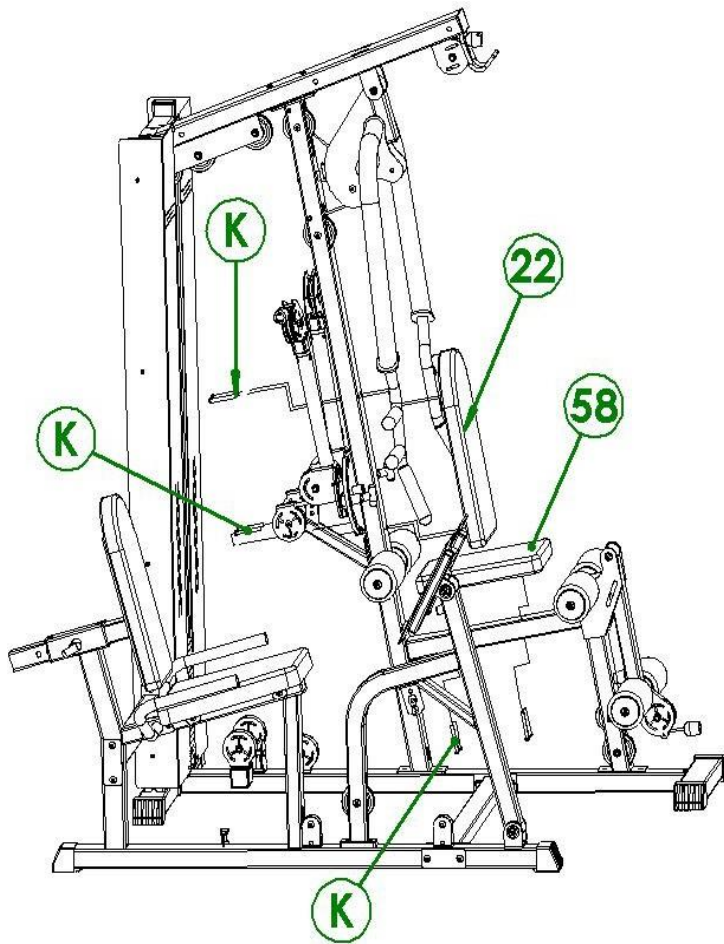

ASSEMBLY STEPS 12

Item NO	Name	Quantity	Item NO	Name	Quantity
NO 24	Foam roller	6	NO 12	Short foam rod set	1
NO 25	Foam bucket inner lid	6	NO 13	Long foam rod set	1
NO 26	Foam barrel outer	6	G	Hexagon socket flat head M10*30	6

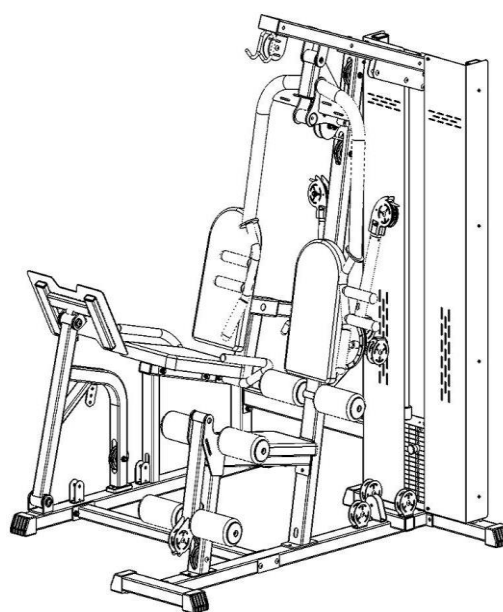
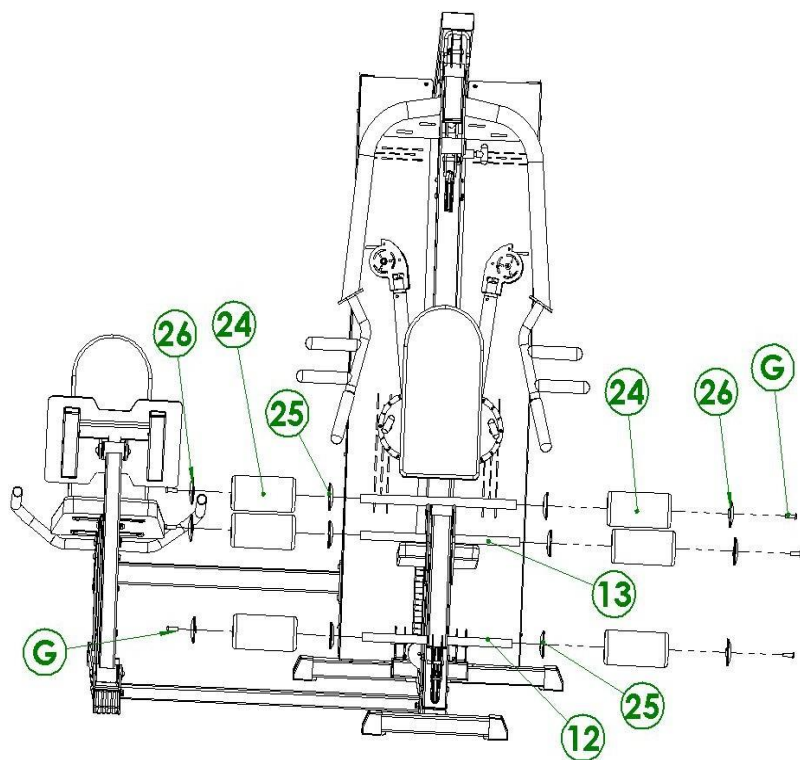

NO 63 Foot pedal assembly*1pc

Step NO	Item NO	Name	Quantity	Item NO	Name	Quantity
	102	Square tube stopper 25*50	4			

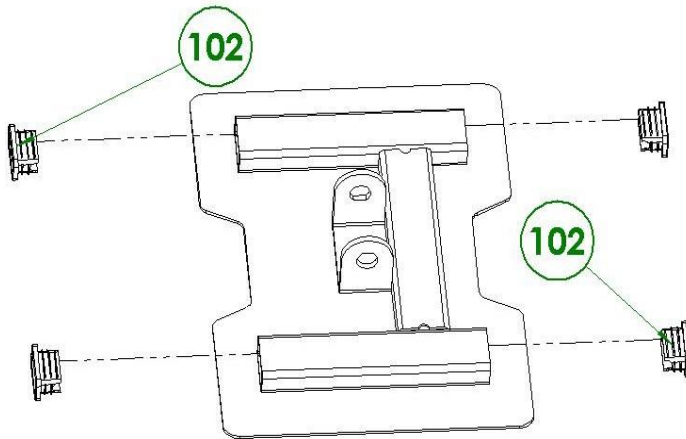

Double hanging pulley assembly*1pc

Step NO	Item NO	Name	Quantity	Item NO	Name	Quantity
	U	Set screws M8	3			

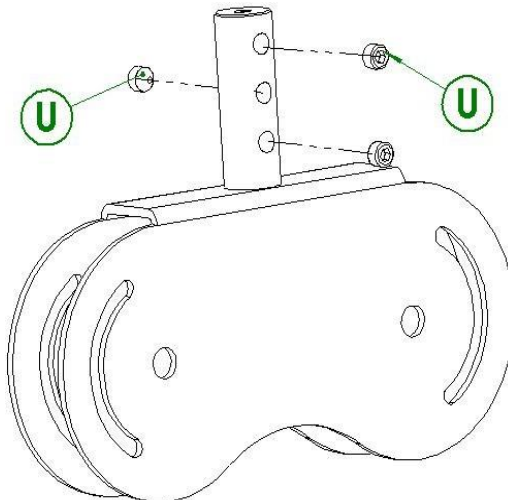

ASSEMBLY STEPS 13

Item NO	Name	Quantity	Item NO	Name	Quantity
NO 31	Wire rope joint	1	NO 43	Tie line fixing sleeve	1
NO 39	Wire rope (large and small head)	1	M	Ø10 Flat gasket	5
NO 15	Pulley combination	2	N	Lock nut M10	5
NO 57	Bayonet rope	2	F	Hexagon socket flat head screws M10*45	4
NO 50	Φ90 Pully	4	R	Hexagon socket flat head screws M10*50	1

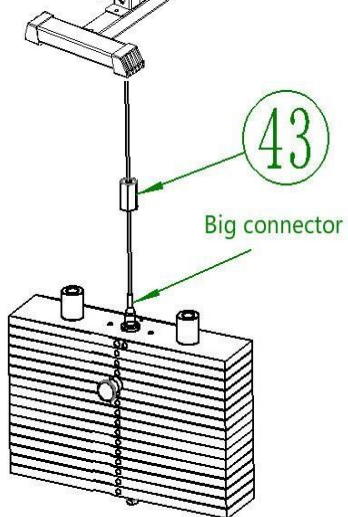
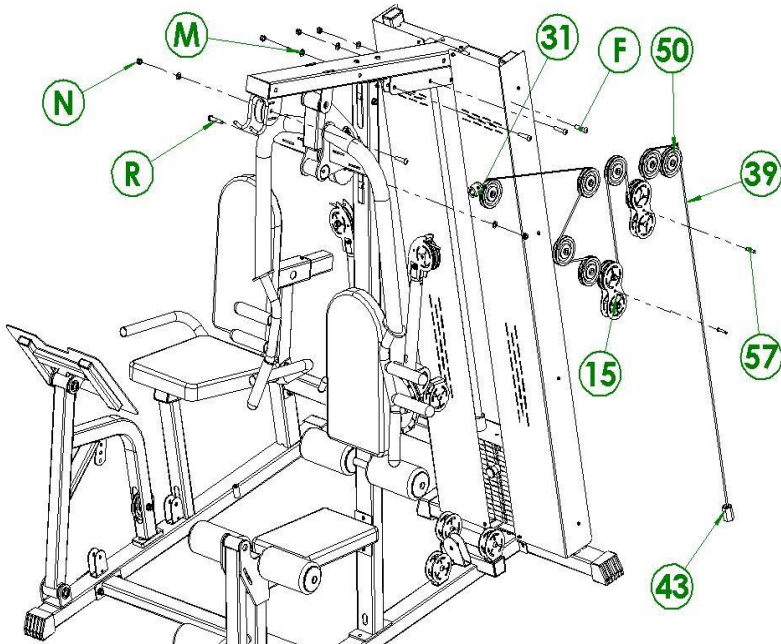

Partial schematic diagram of connection

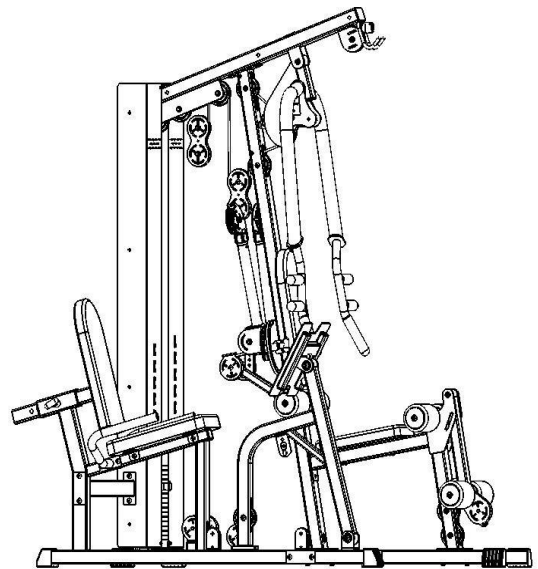

ASSEMBLY STEPS 14

Item NO	Name	Quantity	Item NO	Name	Quantity
NO 15	Pulley combination	1	M	Ø10 flat gasket	3
NO 40	Wire rope (small, flat head)	1	N	Lock nut M10	3
NO 50	Φ90Pully	2	F	Hexagon socket flat head screws M10*45	2
NO 31	Wire rope joint	1	G	Hexagon socket flat head screws M10*30	1

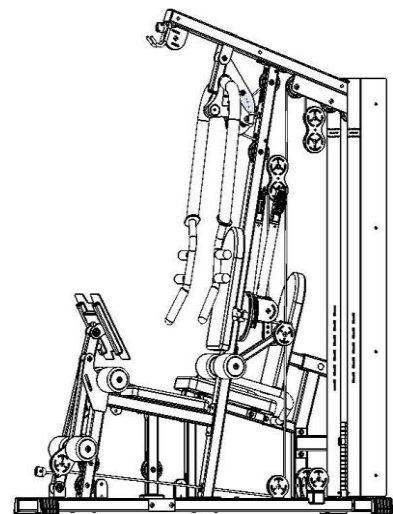
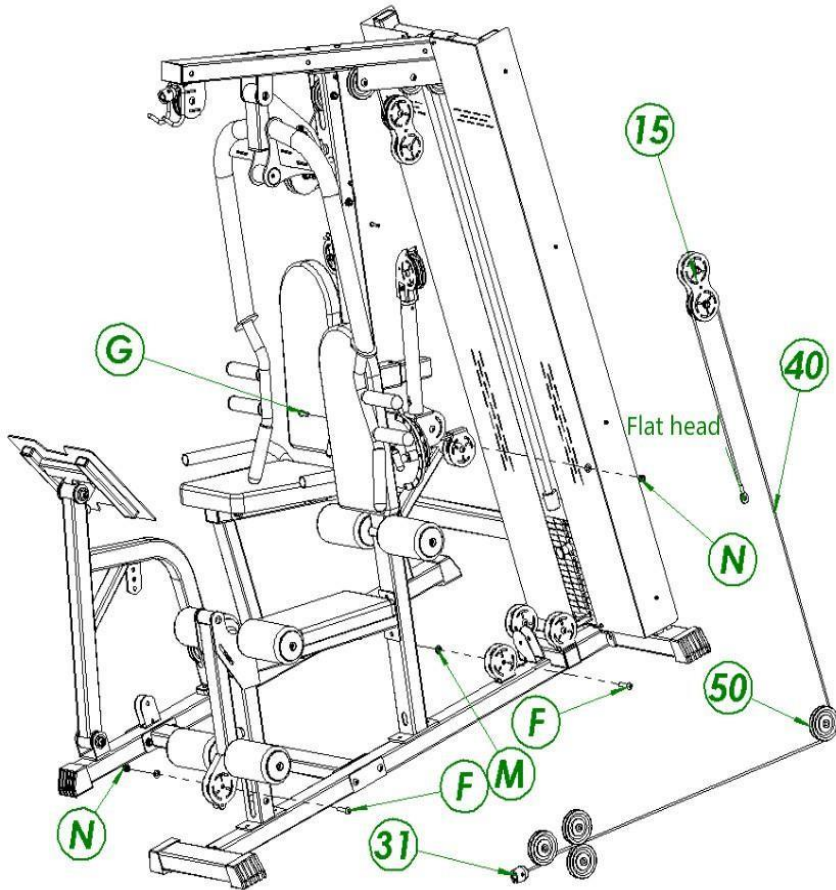

ASSEMBLY STEPS 15

Item NO	Name	Quantity	Item NO	Name	Quantity
NO 57	Bayonet rope	2	NO 50	Φ90Pully	6
F	Hexagon socket flat head screws M10*45	6	NO 42	Wire rope (double small head)	1
NO 31	Wire rope joint	2	M	Ø10 flat gaske	4
NO 14	Double hanging pulley assembly	1	N	Lock nut M10	4

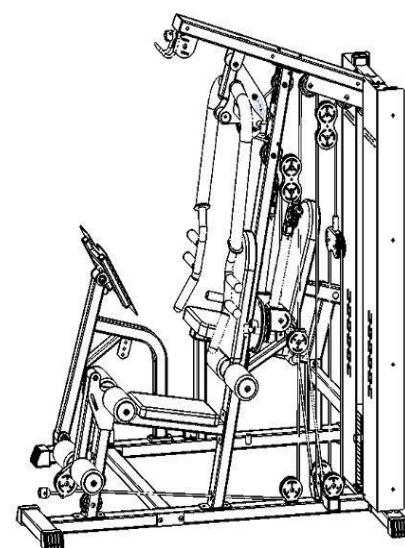
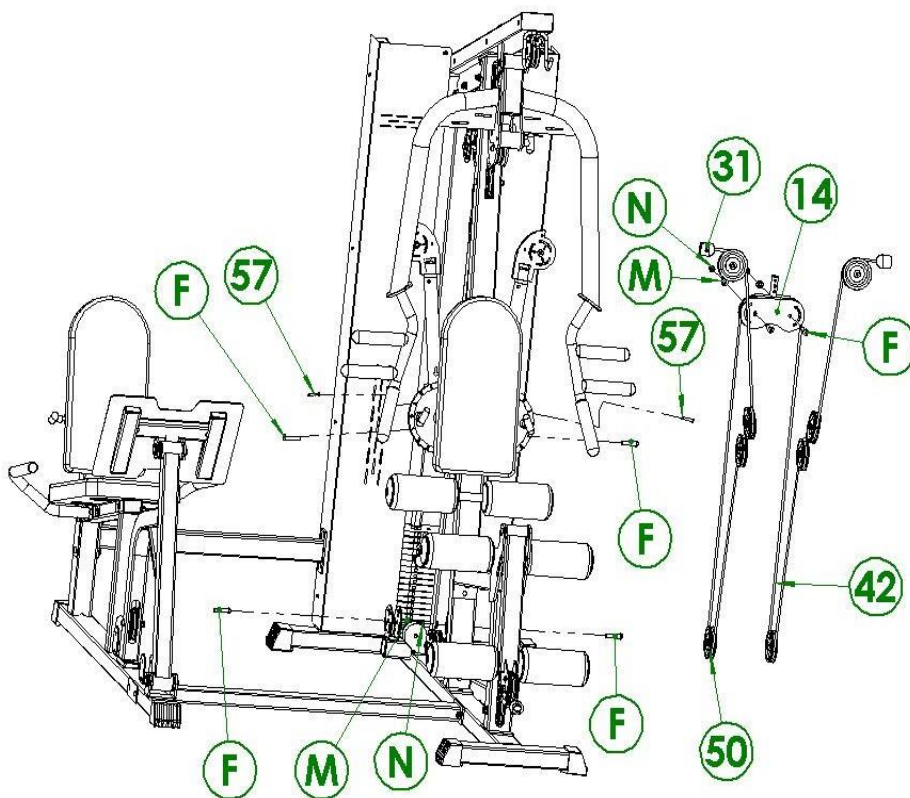

ASSEMBLY STEPS 16

Item NO	Name	Quantity	Item NO	Name	Quantity
NO 41	Wire rope (single flat head)	1	H	Hexagon socket flat head screws M10*20	1
NO 50	Φ90Pully	3	M	Ø10 flat gaske	4
NO 59	Pulley rope sleeve	1	F	Hexagon socket flat head screws M10*45	4
NO 15	Pulley combination	1	N	Lock nuT M10	4
NO 35	Φ80 Pulley	1	NO 57	Bayonet rope	2

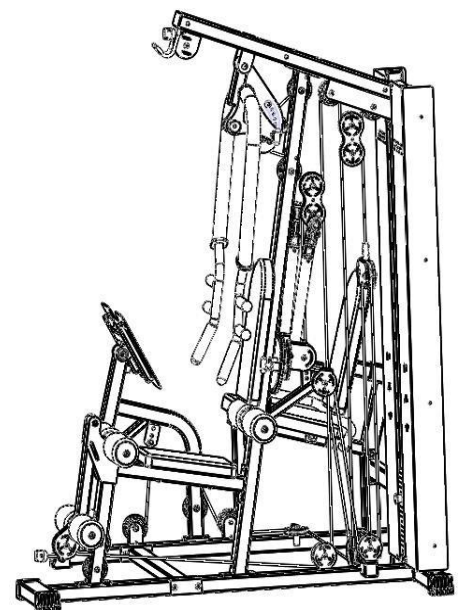
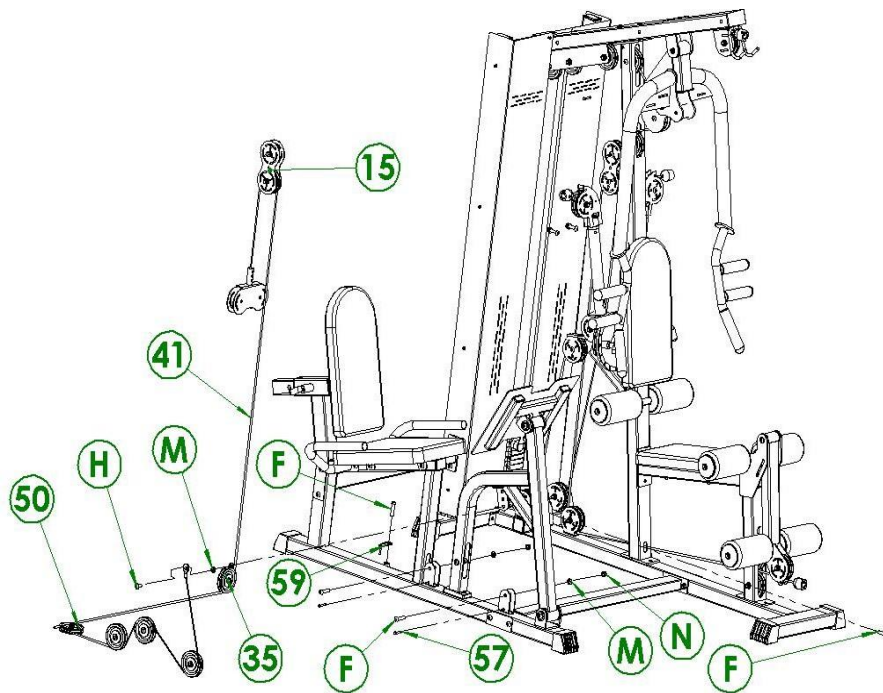

ASSEMBLY STEPS 17

Item NO	Name	Quantity	Item NO	Name	Quantity
A	Hexagon socket flat head screws M10*115	3	N	Lock nut M10	3
NO 21	Upper guard	2			
NO 16	High tensile welding group	1			
M	Ø10 flat gasket	3			

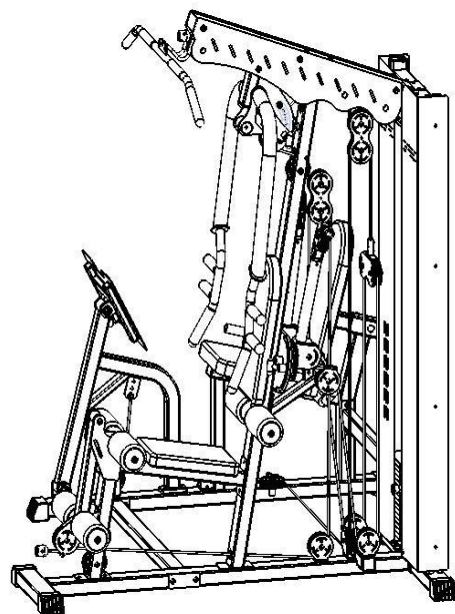
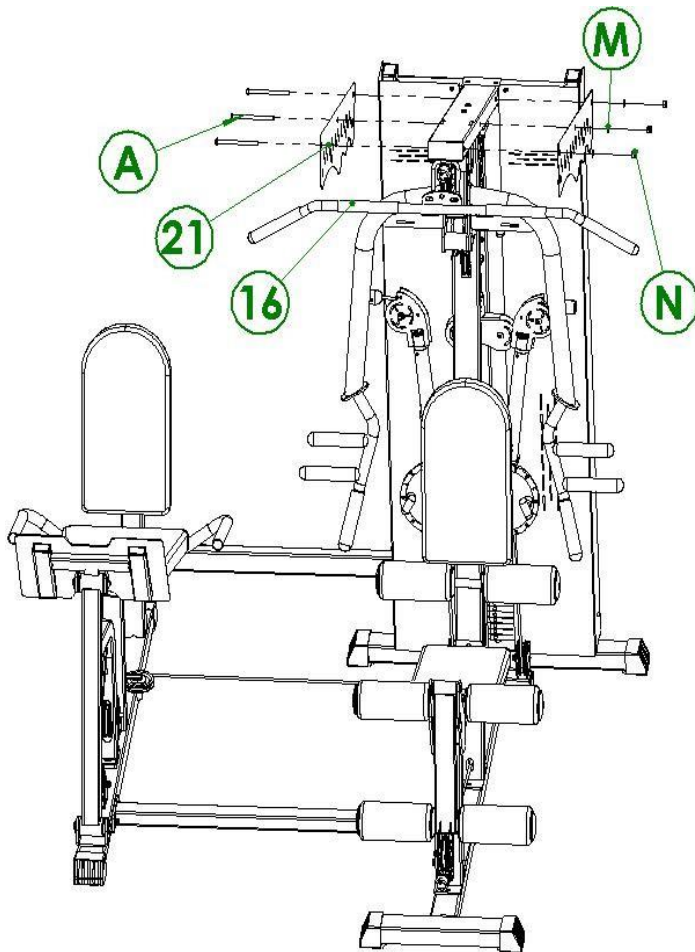

ASSEMBLY STEPS 18

Item NO	Name	Quantity	Item NO	Name	Quantity
NO 29	Standard safety hook	3			
NO 34	Chain 0.35m	3			
NO 17	Low-stretch welding group	1			
NO 30	Low pull handle	2			

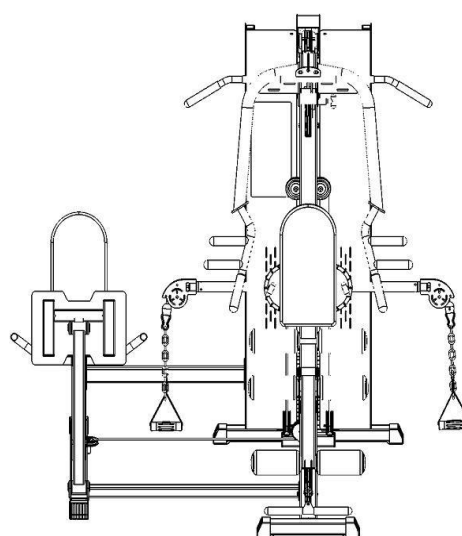
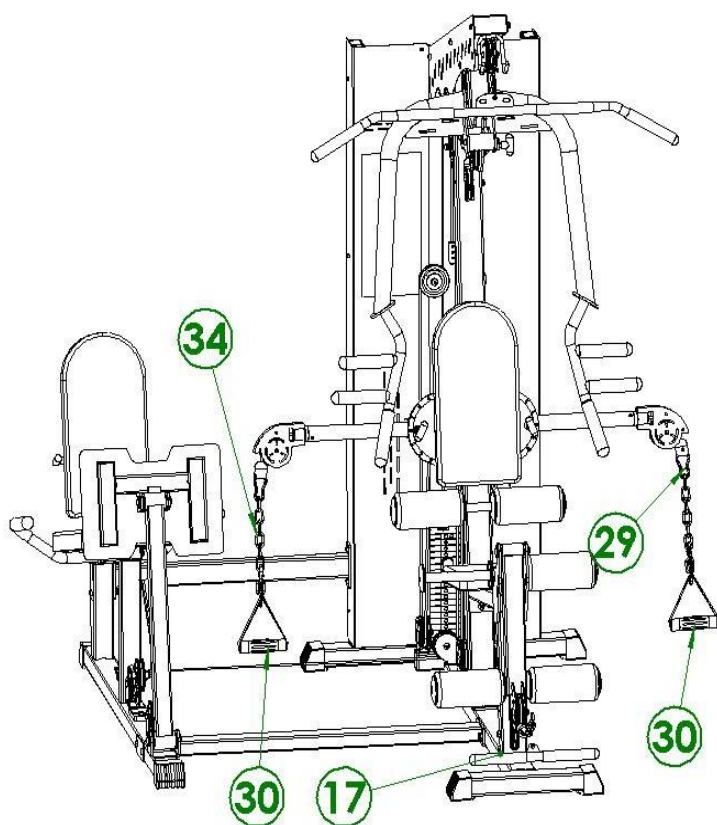

NO.16 High pull welding group *1pc

Step NO	Item NO	Name	Quantity	Item NO	Name	Quantity
	NO 105	Blind tube 170mm	2			
	NO 106	Blind tube 170mm	2			

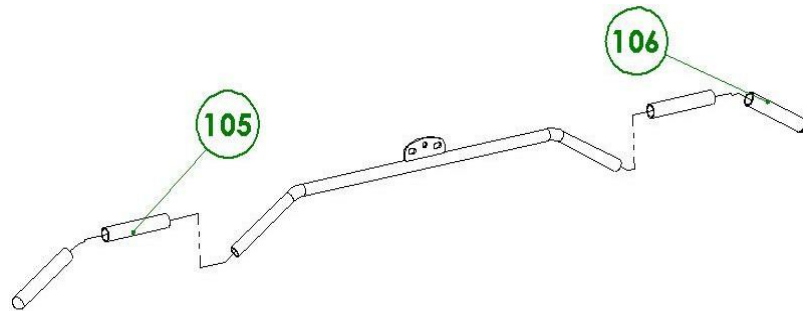

Low-row welding group *1pc

Step NO	Item NO	Name	Quantity	Item NO	Name	Quantity
	NO 106	Blind tube 170mm	2			

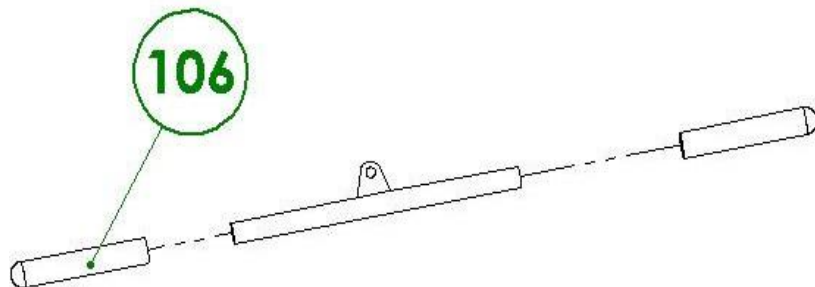

NO 13 Long foam rod set *1pcs

Step NO	Item NO	Name	Quantity	Item NO	Name	Quantity
	NO 82	Black Nut M8	2			



NO 12 Short foam rod set *1pcs

Step NO	Item NO	Name	Quantity	Item NO	Name	Quantity
	NO 82	Black Nut M8	2			

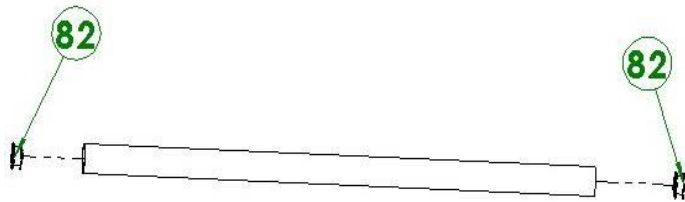

NO 15 Pulley combination*2pcs

Step NO	Item NO	Name	Quantity	Item NO	Name	Quantity
	NO 50	Φ90Pully	2	F	Hexagon socket flat head screws M10*45	2
	NO 59	Pulley rope sleeve	1	N	M10 lock nut	2
	M	Ø10 flat gasket	2			

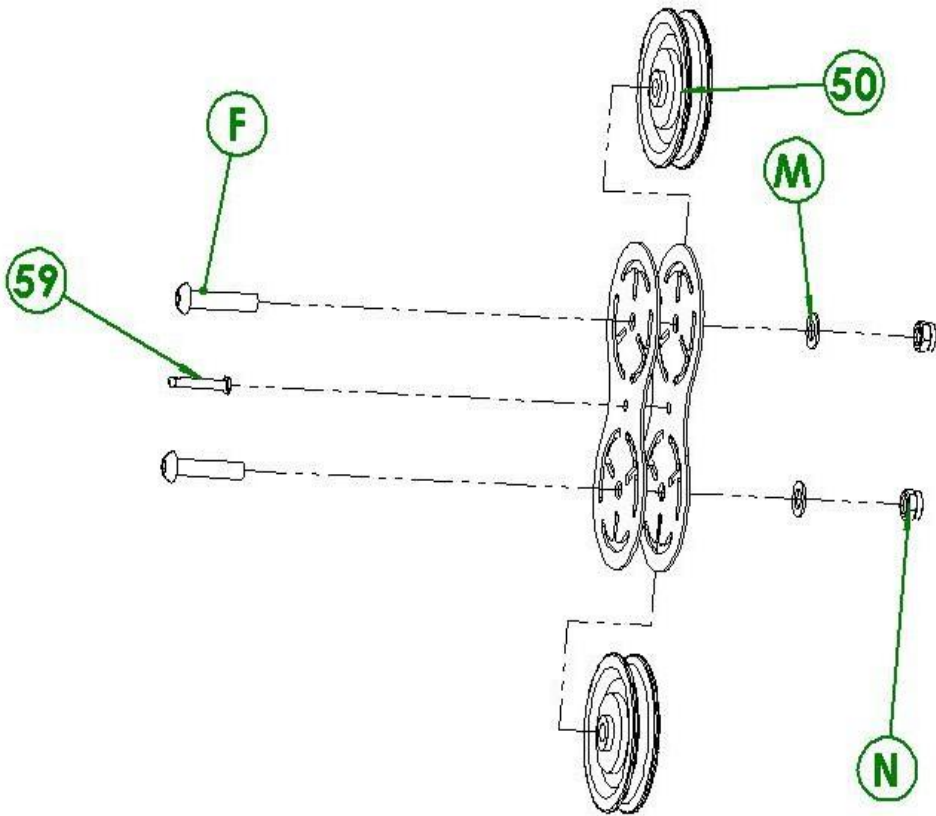



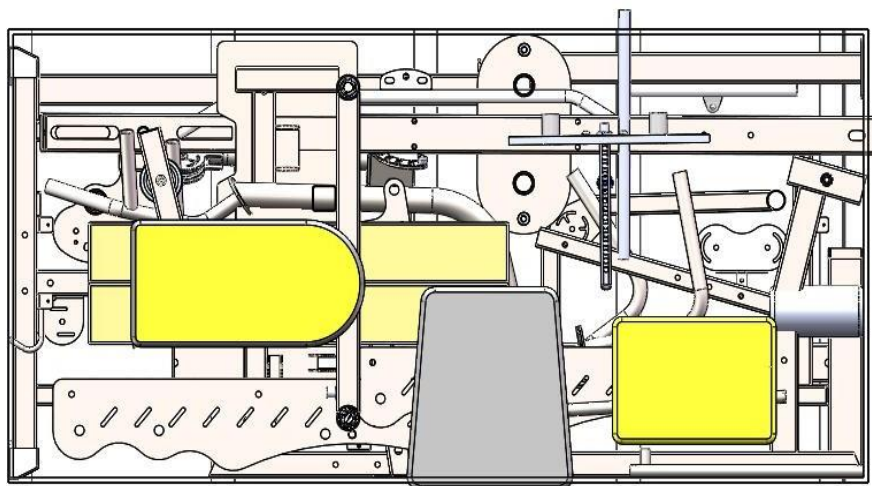





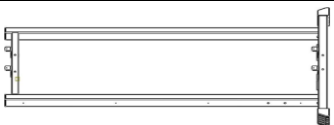
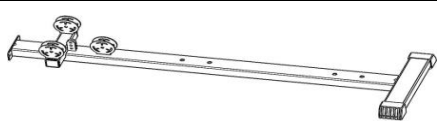
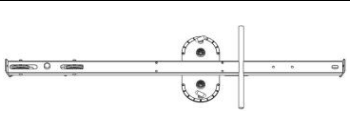
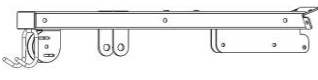

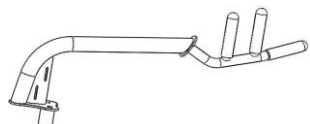
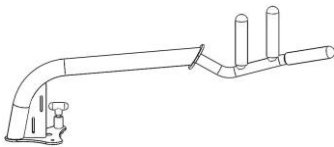
PACKAGE SPECIFICATION

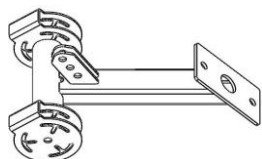
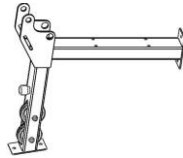



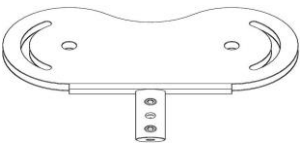
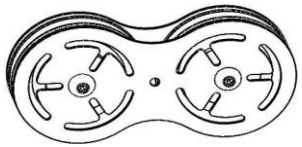
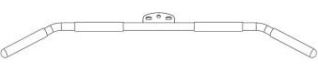
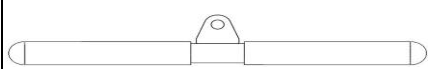
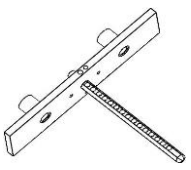
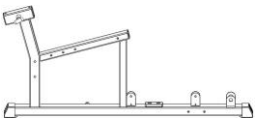
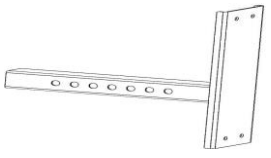
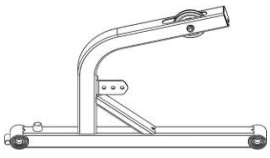
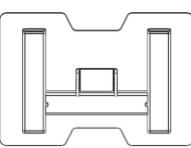
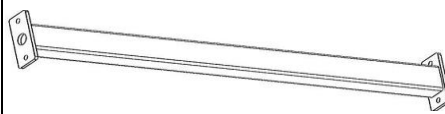





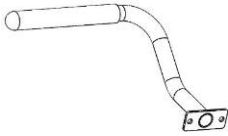
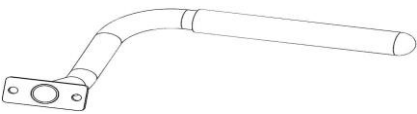
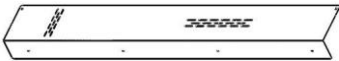
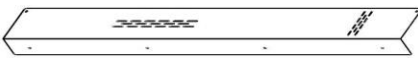

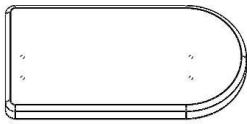
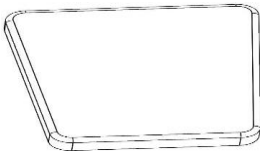
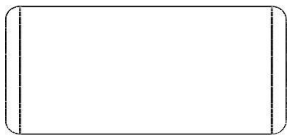

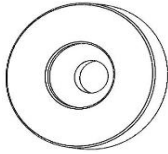
Plywood box inner
size: 1820*870*400mm





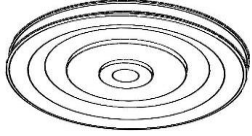





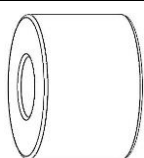

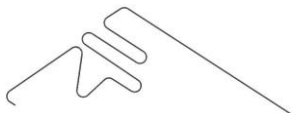
PACKING LIST

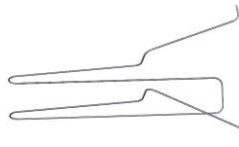
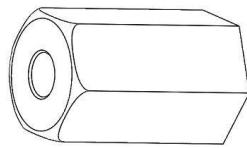
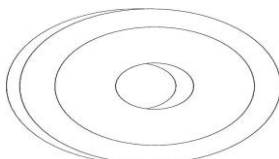
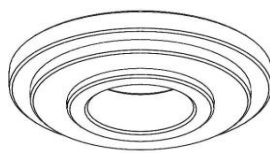
					
NO 1	Small door welding group *1pcs	NO 2	Base components*1pc	NO 3	Inclined column welding group *1pcs
					
NO 4	Upper oblique welding group *1pcs	NO 5	Turntable assembly*1pcs	NO 6	Boom right assembly*1 pcs
					
NO 7	Boom left assembly*1pcs	NO 8	Cable boom welding group*2pcs	NO 9	Guide component *1pc
					
NO 10	Bracket component *1pcs	NO 11	Leg arm assembly*1p	NO 12	Short foam rod set *1pcs
					
NO 13	Long foam rod set *1pcs	NO 14	Double hanging pulley assembly*1pcs	NO 15	Pulley combination * 2 pcs
					
NO 16	High tensile welding group *1pcs	NO 17	Low-stretch welding group *1pcs	NO 18	Counterweight component *1pcs
					
NO 60	Leg press welding group*1pcs	NO 61	Backrest*1pcs	NO 62	Leg press boom welding group*1pcs
					
NO 63	Foot pedal assembly*1pcs	NO 64	Upper connection component *1pcs	NO 65	Lower connection component *1pcs

PACKING LIST

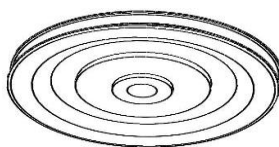
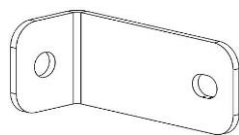
					
NO 66	Right handle assembly *1pcs	NO 67	Left hand handle assembly *1pcs		
Packing list-2					
					
NO 19	Left guard plate*1 pcs	NO 20	Right guard plate*1 pc	NO 21	Upper guard * 2 pcs
					
NO 22	Backrest*2pcs	NO 23	Seat cushion*1 pcs	NO 24	Foam roller *6 pcs
					
NO 25	Foam bucket inner lid*6 pcs	NO 26	Foam barrel outer cover*6 pcs	NO 27	Aluminum alloy end cover*2pcs
					
NO 28	Nylon spacer*2 pcs	NO 29	Standard safety hook * 4 pcs	NO 30	Low pull handle*2 pcs
					
NO 31	Wire rope joint * 4 pcs	NO 32	Small door optical axis * 2pcs	NO 33	Counterweight bolt *1pcs
					
NO 34	Chain 0.35m*3 pcs	NO 35	Φ80 Pulley*1pcs	NO 36	Rotating shaft*2 pcs

PACKING LIST

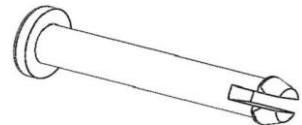
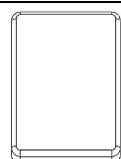
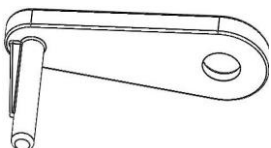
		
NO 37 Weight piece rubber sleeve * 2 pcs	NO 38 Long weight stack * 15 pcs	NO 39 Wire rope (large and small head) *1pcs
		
NO 40 Wire rope (small, flat head) *1pcs	NO 41 Wire rope (single flat head) *1pcs	NO 42 Wire rope (double small head) *1pcs
		
NO 43 Tie line fixing sleeve *1pcs	NO 44 Gasket *10 pcs	NO 45 Upper nylon sleeve * 8pcs
		
NO 46 Joint shaft *1pcs	NO 47 Blister pack *1pcs	NO 48 Manual *1pcs
		
NO 49 Optical axis fixing plate *1pcs	NO 50 $\Phi 90$ Pully *28 pcs	NO 51 Cushion connecting plate * 4pcs
		
NO 52 Assemble lock plate 140*50*1pcs	NO 53 Assemble lock plate 120*50*4pcs	NO 54 Assemble lock plate 150*40*1pcs
		
NO 55 Pulley limit sleeve * 2 pcs	NO 56 Training image *1pcs	NO 57 Bayonet rope *6 pcs
		
NO 58 Cushion *1pcs	NO 59 Pulley rope sleeve *1pcs	

PACKING STEP 1

Item NO	Name	Quantity	Item NO	Name	Quantity
NO 1	Small door welding group	1	NO 11	Leg arm assembly	1
NO 2	Base components	1	NO 14	Double hanging pulley assembly*	1
NO 3	Inclined column welding group	1	NO 16	High tensile welding group	1
NO 5	Turntable assembly	1	NO 17	Low-stretch welding group	1
NO 9	Guide component	1	NO 18	Counterweight component	1

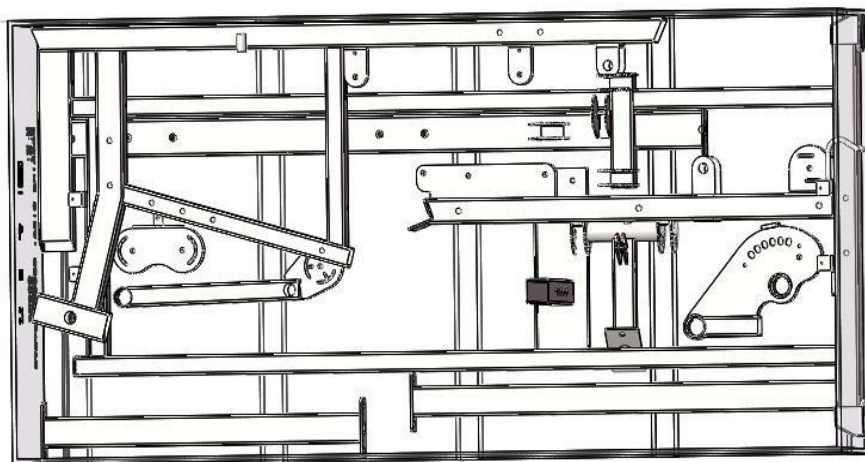
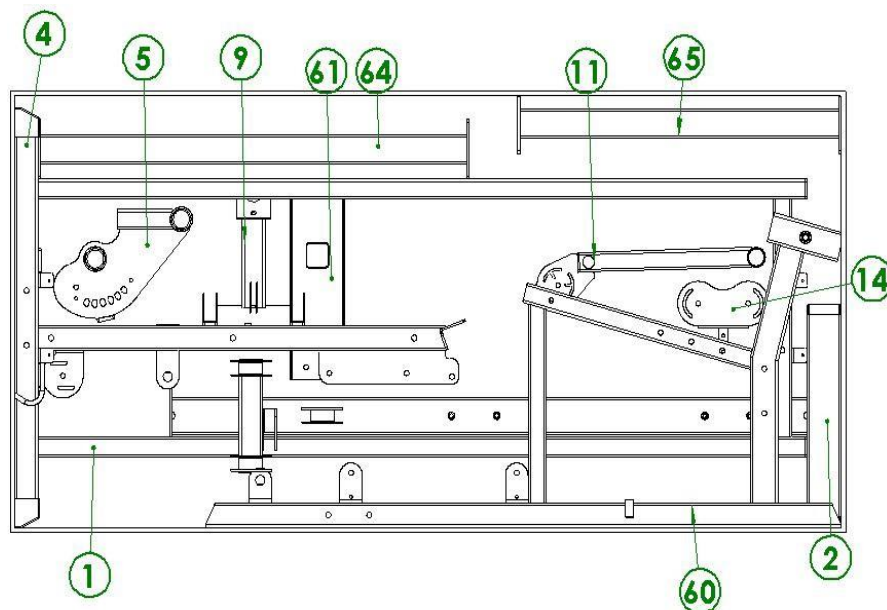

PACKING STEP 2

Item NO	Name	Quantity	Item NO	Name	Quantity
NO 8	Cable boom welding group	2	NO 38	Long weight stack	15
NO 16	High tensile welding group	1			
NO 17	Low-stretch welding group	1			
NO 18	Counterweight component	1			
NO 15	Pulley combination	2			
NO 10					

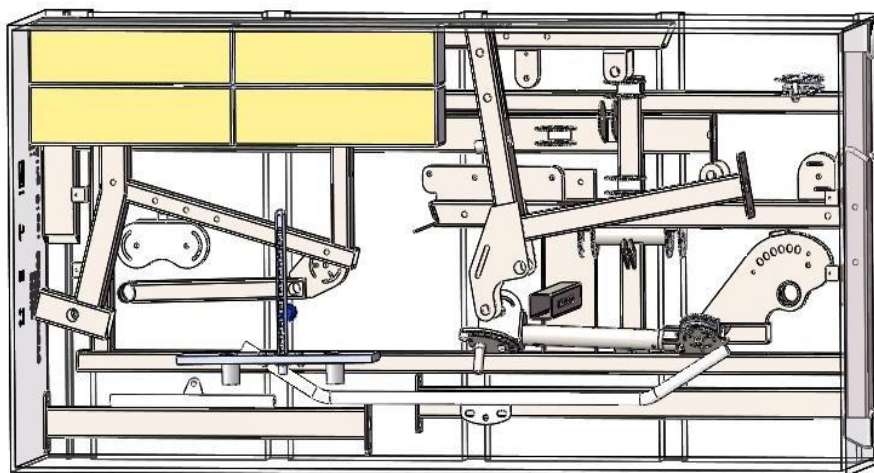
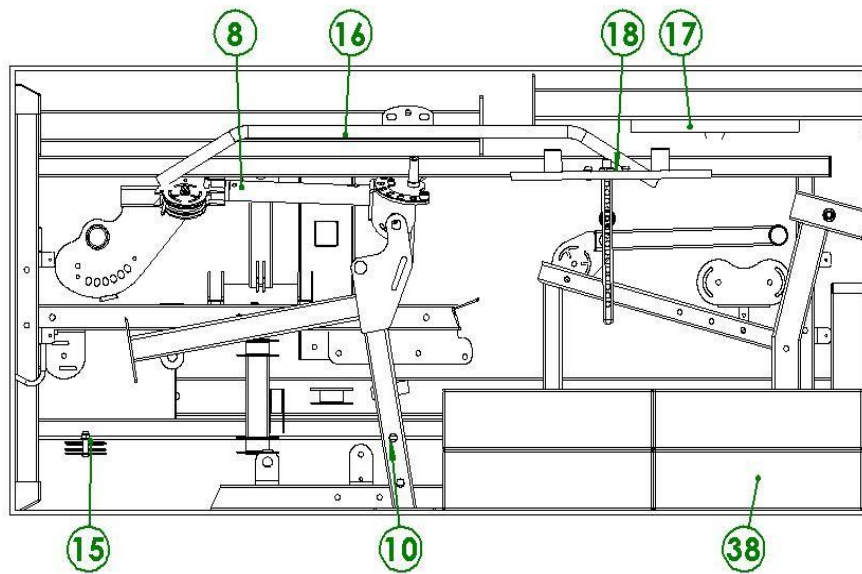

PACKING STEP 3

Item NO	Name	Quantity	Item NO	Name	Quantity
NO 63	Foot pedal assembly	1			
NO 3	Inclined column welding group	1			
NO 67	Left hand handle assembly	1			
NO 66	Right hand handle assembly	1			
NO 12	Short foam rod set	1			
NO 13	Long foam rod set	1			

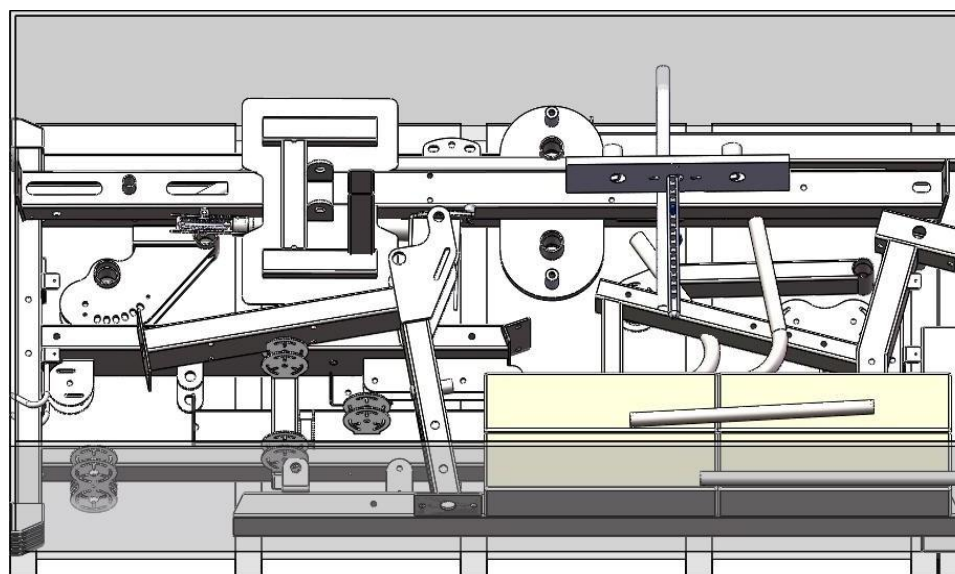
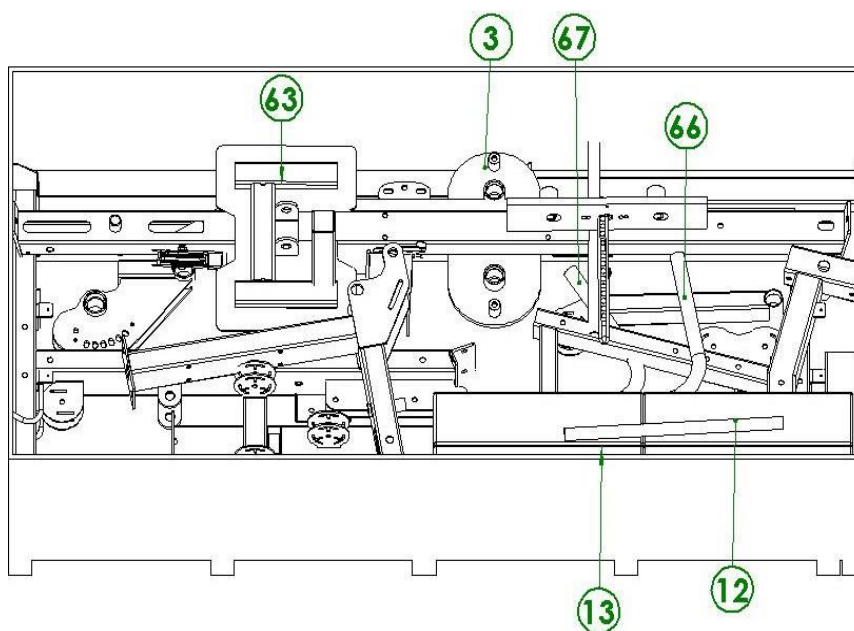

PACKING STEP 4

Item NO	Name	Quantity	Item NO	Name	Quantity
NO 7	Boom left assembly	1	NO 20	Right guard plate	1
NO 6	Boom right assembly	1	NO 21	Upper guard	1
NO 19	Left guard plate	1			

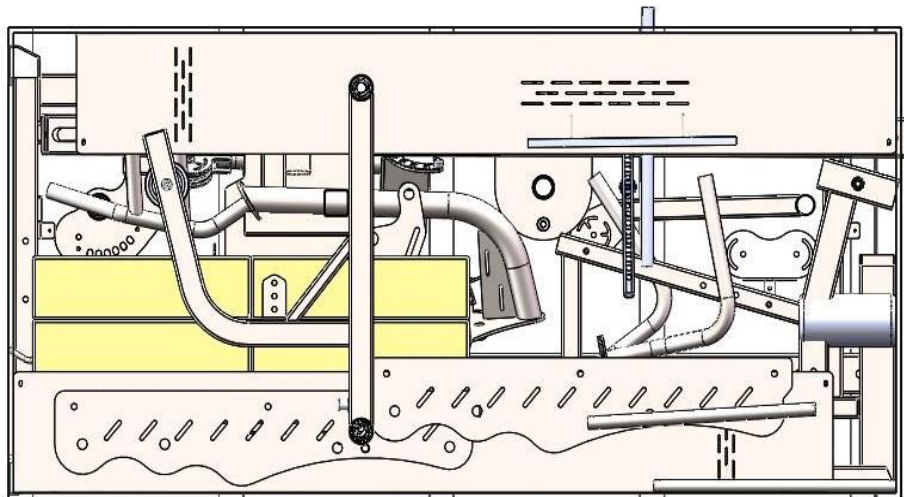
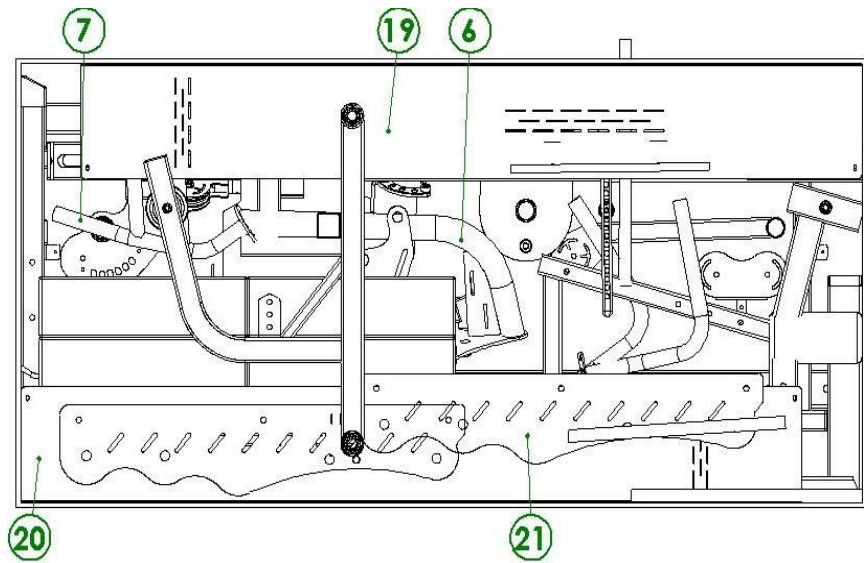

PACKING STEP 5

Item NO	Name	Quantity	Item NO	Name	Quantity
NO 22	Backrest	2			
NO 58	Cushion	1			
NO 23	Seat cushion	1			

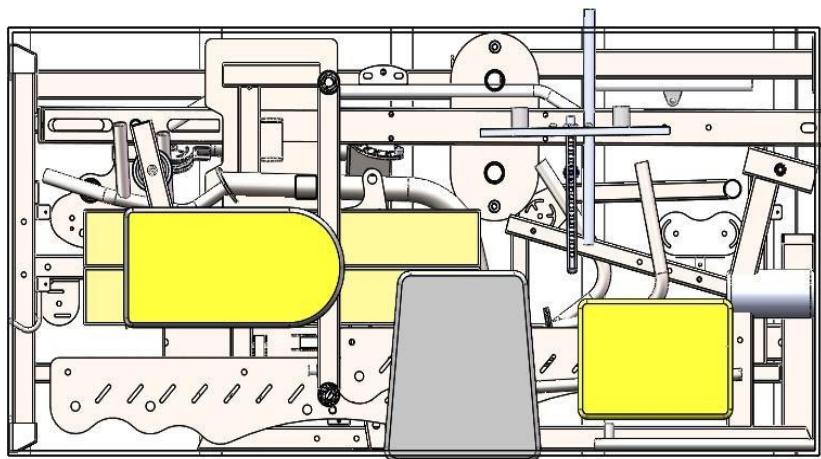
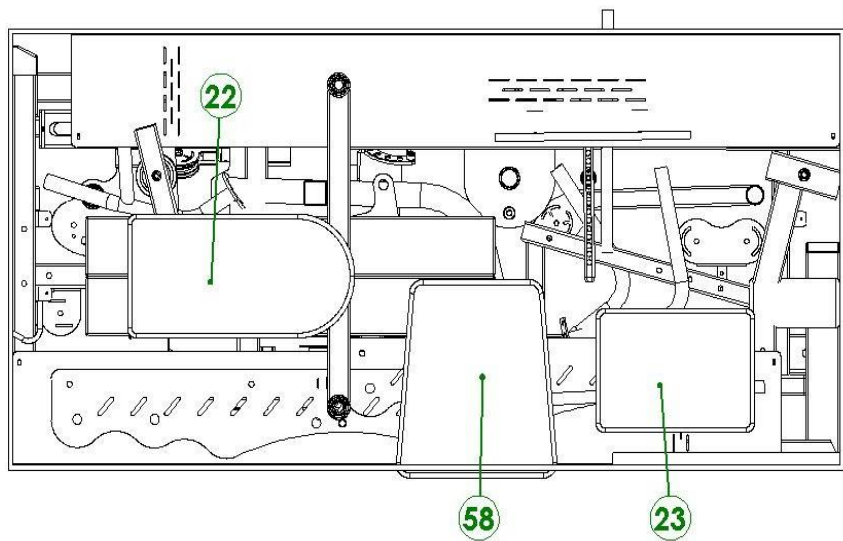

The packing diagram does not include all the accessories. The packing accessories are based on the packing schedule. The weight stack are packed according to the actual number of pieces. The remaining small accessories that are not marked are separately packed together and placed in the empty gaps of the box to complete all the packing and seal the box.