

FRENCH FITNESS

FFS-PFRD / FFT-PFRD

French Fitness Shasta & Tahoe
Pec Fly / Rear Delt

ASSEMBLY MANUAL



FEATURES

- 50 x 100 mm thickness 3mm Steel tube
- Q235 steel frame ensures maximum structural integrity
- Each frame receives an electrostatic powder coat finish to ensure maximum adhesion and durability
- Standard rubber feet protect base of the frame and prevent the machine from slipping
- Nylon-coated cable meets U.S. military specifications
- Fiberglass-impregnated nylon pulleys feature sealed bearings
- Grips retained with aluminum collars, preventing them from slipping during use
- Hand grips are a durable urethane composite
- Solid-steel weight plates. Top weight plate is fitted with self-lubricating bushings
- Weight selector pin magnetically locks in place and is connected to stack to prevent loss
- Standard rear shrouds

TECH SPECS

- Dimensions: 49" x 56" x 71" (1240 x 1420 x 1800 mm)
- Machine Weight: 408 lb (185 kg)
- Weight stack: 212 lb (96 kg)
- (16) Weight Plate, EA 13.23 Lb (6 kg)
- Weight to Pulley Ratio: 1:1

WARRANTY

10 Years Parts, 1 Year Labor (Commercial)

TABLE OF CONTENTS

PARTS LIST4

CLEAN GUIDE RODS5

ARM ASSEMBLY6

FRAME ASSEMBLY.....7

WEIGHT STACK ASSEMBLY.....8

PARTS LIST

ITEM NO.	Name	QTY.	ITEM NO.	Name	QTY.
1	Ass, The adjusting disk	2	16	Φ114MM Pulley	3
2	Bearing 6205	4	17	Main Frame	1
3	The adjusting disc	1	18	Elastic Pin 10*40	4
4	Bushing 38*32*25*3	4	19	Guide Rod Sleeve	2
5	Axle, 100L	2	20	Screw, M8X55	2
6	Bushing 38*32*18*3	4	21	Placard	2
7	Screw, M12X25	4	22	Screw, M6X10	8
8	Arm	1	23	Guide Rod Sleeve Nut	2
9	Cushion	2	24	Guide Rod, 1.58M	2
10	5 hole regulation board	2	26	Button Head Cap	1
11	Screw, M12X20	4	27	Counter Weight Cushion	2
12	Back Cushion	1	28	Weight Stack Adapter (Top)	1
13	Seat Cushion	1	29	Weight Stack Adapter (Bottom)	1
14	Short Handle	1	30	Shroud	1
15	Support	2	31	Screw	12

CLEAN GUIDE RODS

Step must be completed prior to installing. Failure to do so can leave residue from packaging and other sources stuck in the bushings

Guide rods need to make sure they are cleaned prior to installation otherwise this will cause the top plate to get stuck. It causes buildup in the bushings of the top plates. They just need to be cleaned out as well as the guide rods.

Use Silicon Spray and fiber to remove any excess residue. These can be found around the house or at a nearby hardware store, pics below. Use silicon Spray and fiber.

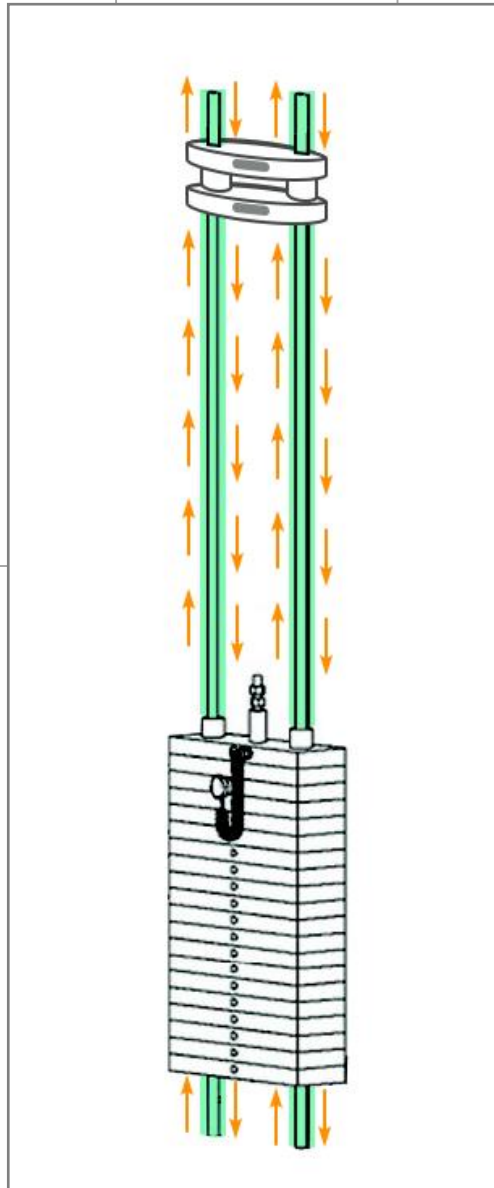

ARM ASSEMBLY

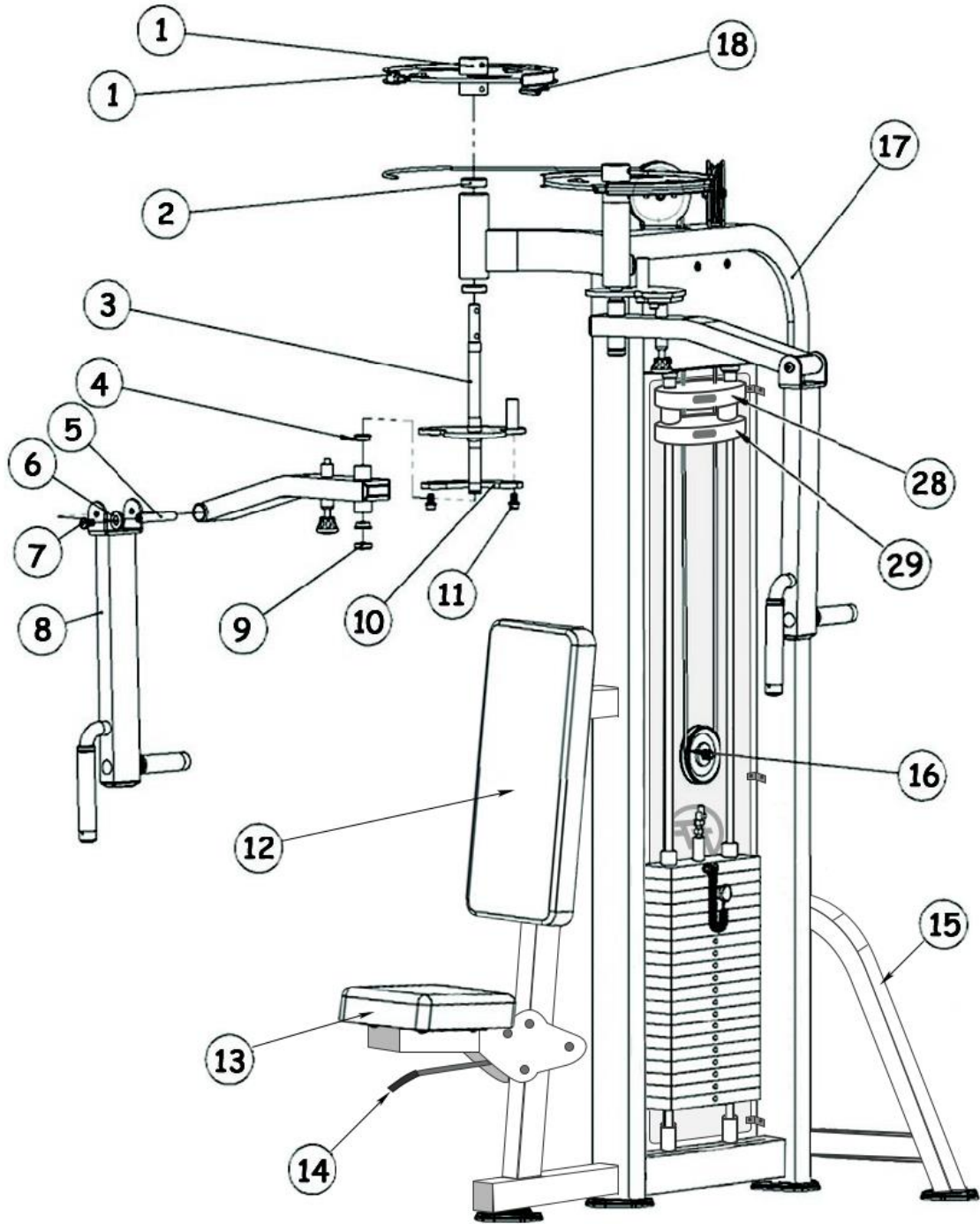

FRAME ASSEMBLY

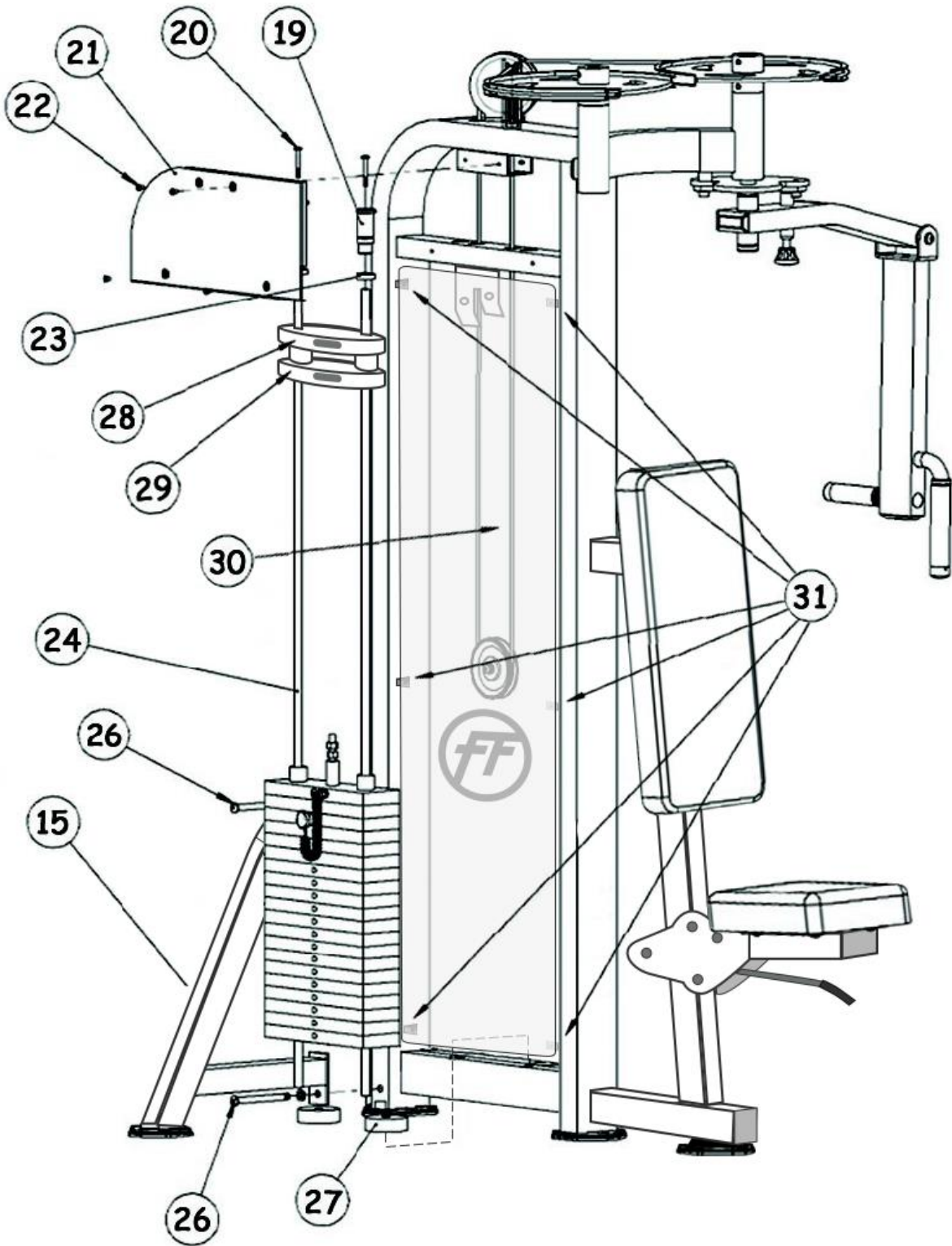

WEIGHT STACK ASSEMBLY

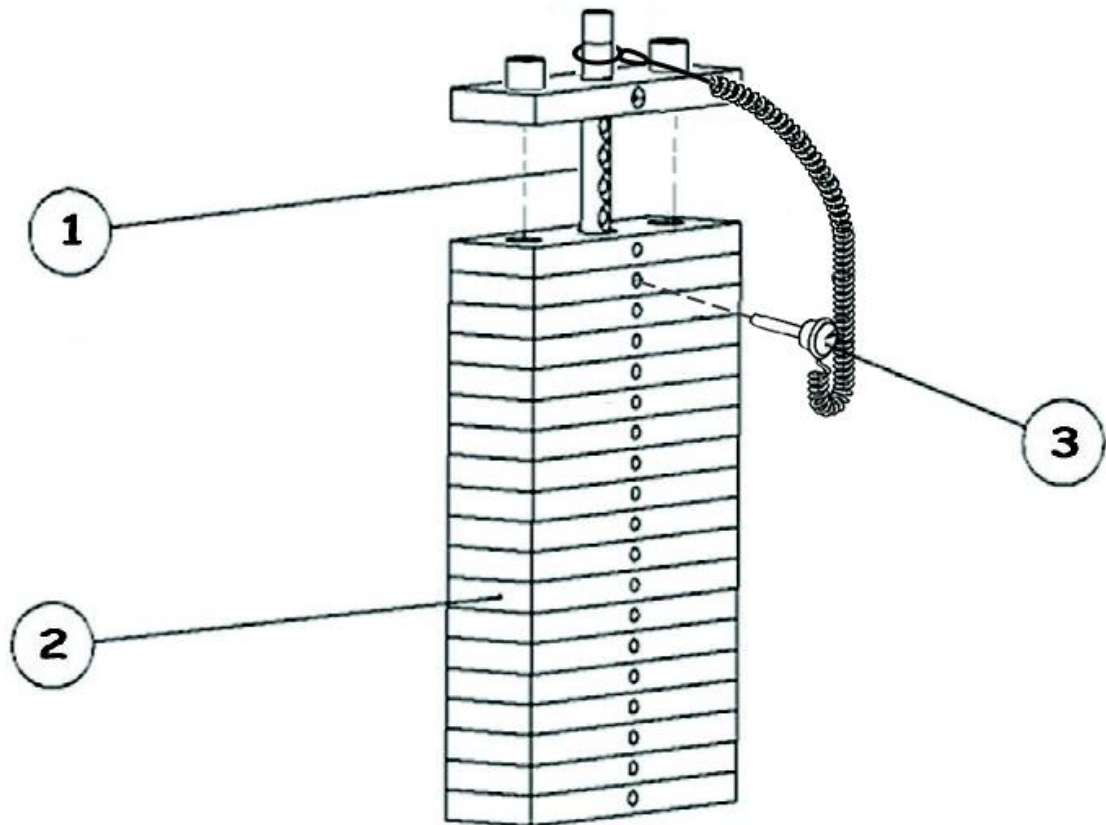

ITEM NO.	Name	QTY.
1	Pole, 20 Hole	1
2	Underside Weight Plate	19
3	Adjustable bolt	1