

FRENCH FITNESS

FF-SC15

FRENCH FITNESS FF-SC15 STRETCH CAGE

ASSEMBLY MANUAL



FEATURES

- High quality steel tube Q235 with 50 x 80 x 3mm
- Tungsten Inert Gas (TIG) welding
- Quality PU leather
- Electrostatic powder coating

TECH SPECS

- Weight: 398 lb (180 kg)
- Dimensions: 87"L x 61"W x 48"H (2210 mm x 1530 mm x 1220 mm)

WARRANTY

10 Years Parts, 1 Year Labor (Commercial)

ASSEMBLY SEQUENCE DIAGRAM

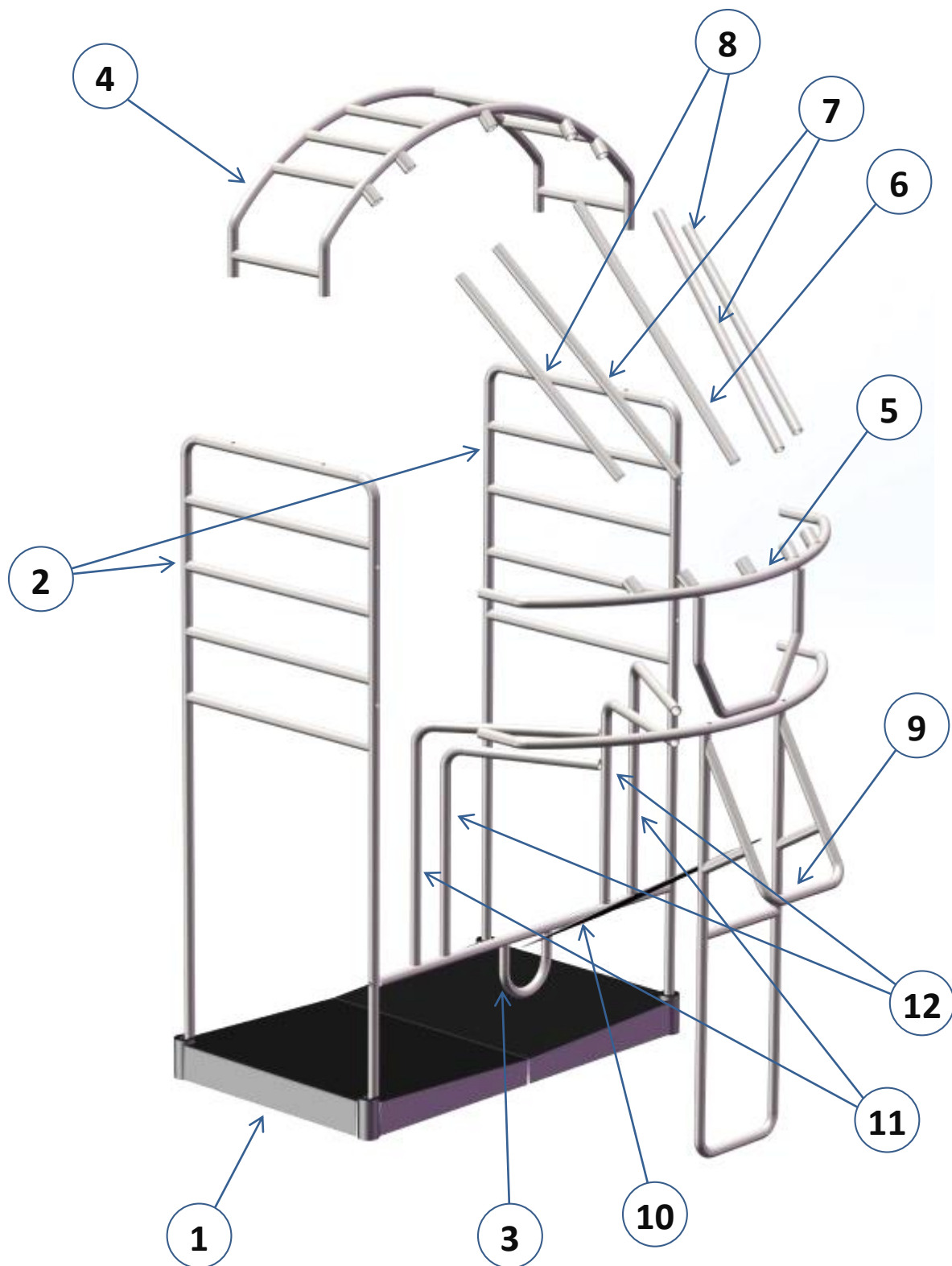

- * Start with step 1, and continue through step 12.
- * Do not fully tighten screws / fasteners until all items are in place.
- * Once step 12 is complete tighten all screws / fasteners.