

FRENCH FITNESS

FFN-PLHAA / FFM-PLHAA

FRENCH FITNESS NAPA / MARIN
HIP ABDUCTOR / ADDUCTOR PLATE
LOADED (NEW)

ASSEMBLY MANUAL



FEATURES

- Performs 2 Movements:
 - Outer Thigh (Hip Abductor)
 - Inner Thigh (Hip Adductor)
- 12 Gauge Steel
- Combination of 2" x 4" x 2.5mm and 1.5" x 3" x 2.5mm steel tube
- ASTM A36 steel frame ensures maximum structural integrity
- Each frame receives an electrostatic powder coat finish to ensure maximum adhesion and durability
- Standard rubber feet protect base of the frame and prevent the machine from slipping
- Built-in weight horns hold multiple plate sizes.

TECH SPECS

- Shipping Dimensions: 63"L x 51.2"W x 51.8"H (160cm x 130cm x 131.5cm)
- Machine Weight: 220 lb (100 kg)



WARRANTY

- **10 Years Parts, 1 Year Labor (Commercial)**
- **California Residents see Prop 65 WARNING**

TABLE OF CONTENTS

ACCESSORIES LIST (SEPARATE PACKAGING).....	4
ASSEMBLY STEPS.....	6

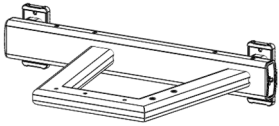
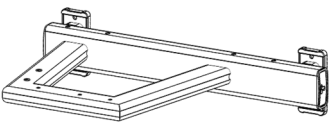
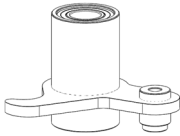
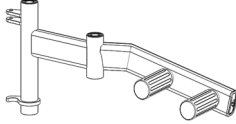
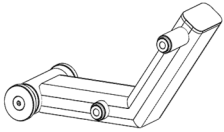
ACCESSORIES LIST (SEPARATE PACKAGING)

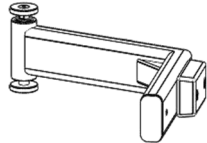
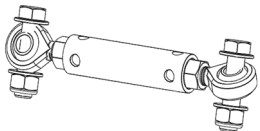
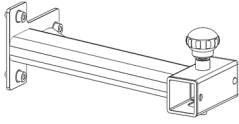
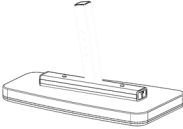
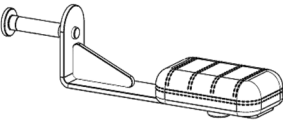
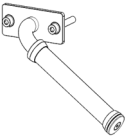
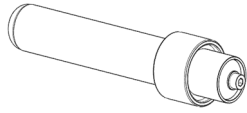
					
No.1	8139-0100ASSY*1pc	No.2	8139-0200ASSY*1pc	No.3	8139-0400ASSY*1pc
					
No.4	8139-0500ASSY*1pc	No.5	8139-1400ASSY*1pc	No.6	8139-1500ASSY*1pc
					
No.7	8139-1600ASSY*1pc	No.8	8139-1200ASSY*1pc	No.9	8139-1300ASSY*1pc
					
No.10	8139-0700ASSY*1pc	No.11	8139-1900ASSY*2pcs	No.12	8139-0300ASSY*1pc
					
No.13	8139-0600ASSY*1pc	No.14	8139-2000ASSY*1pc	No.15	8139-2100ASSY*1pc
					
No.16	8139-0800ASSY*1pc	No.17	8139-0900ASSY*1pc	No.18	8139-1700ASSY*2pcs
					
No.19	8139-1000ASSY*1pc	No.20	8139-1100ASSY*1pc	No.21	Q1001-32ASSY*1pc

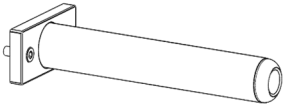

No.22

04-8101-1200
ASSY*2pcs

Blister Pack Screw List

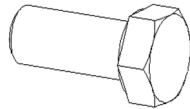
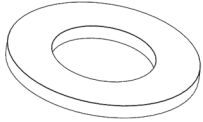

A

IMP-GB95*4pcs

B

GB5780M12*30*4pcs

ASSEMBLY STEPS

Step	Item NO	Name	Qty
1	1	8139-0100ASSY	1
	2	8139-0200ASSY	1
	3	8139-0400ASSY	1
	4	8139-0500ASSY	1

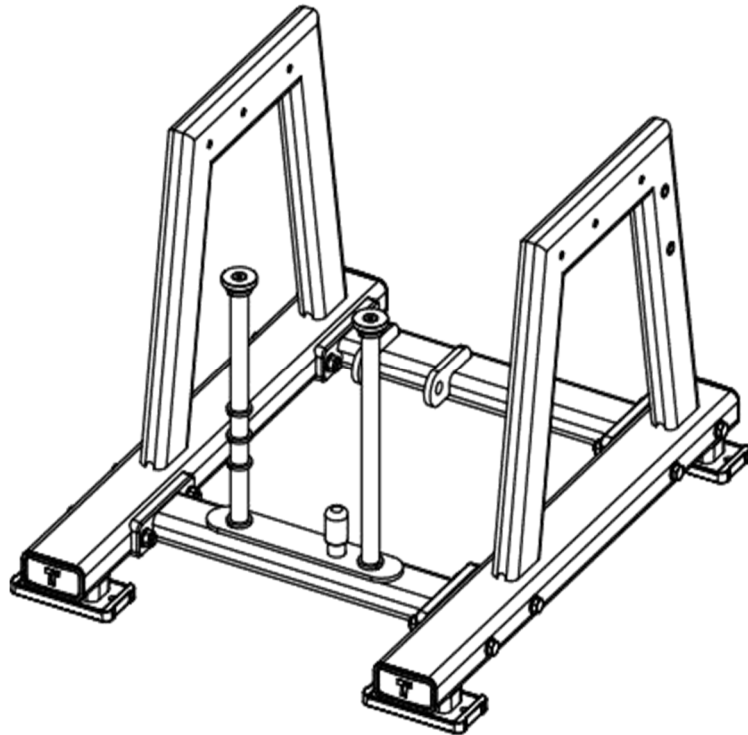
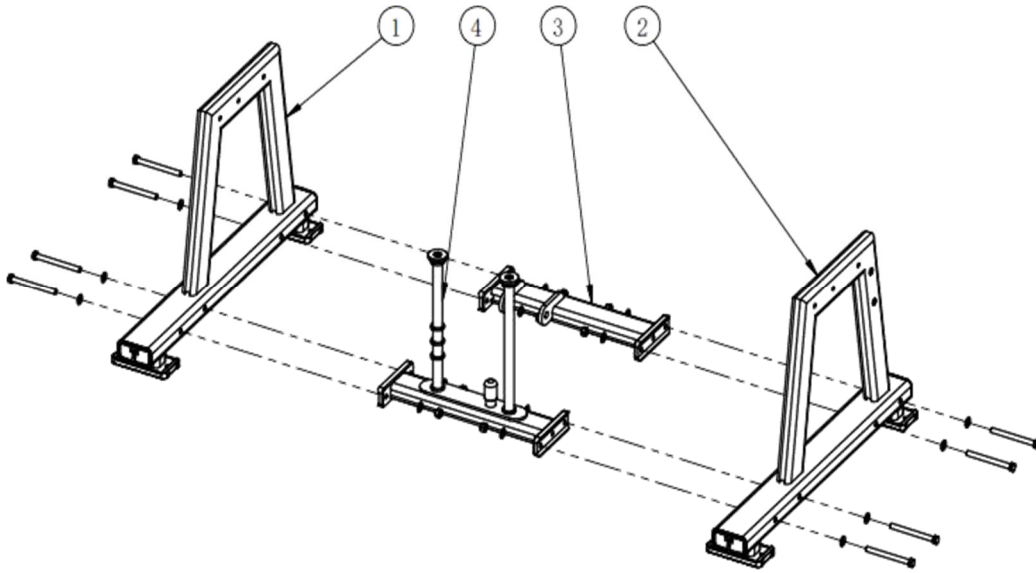

ASSEMBLY STEPS

Step	Item NO	Name	Qty
2	5	8139-1400ASSY	1
	6	8139-1500ASSY	1
	7	8139-1600ASSY	1

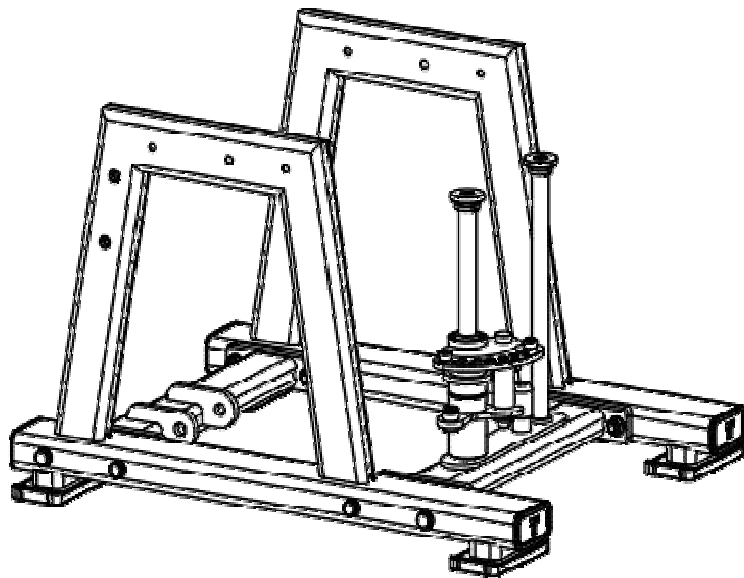
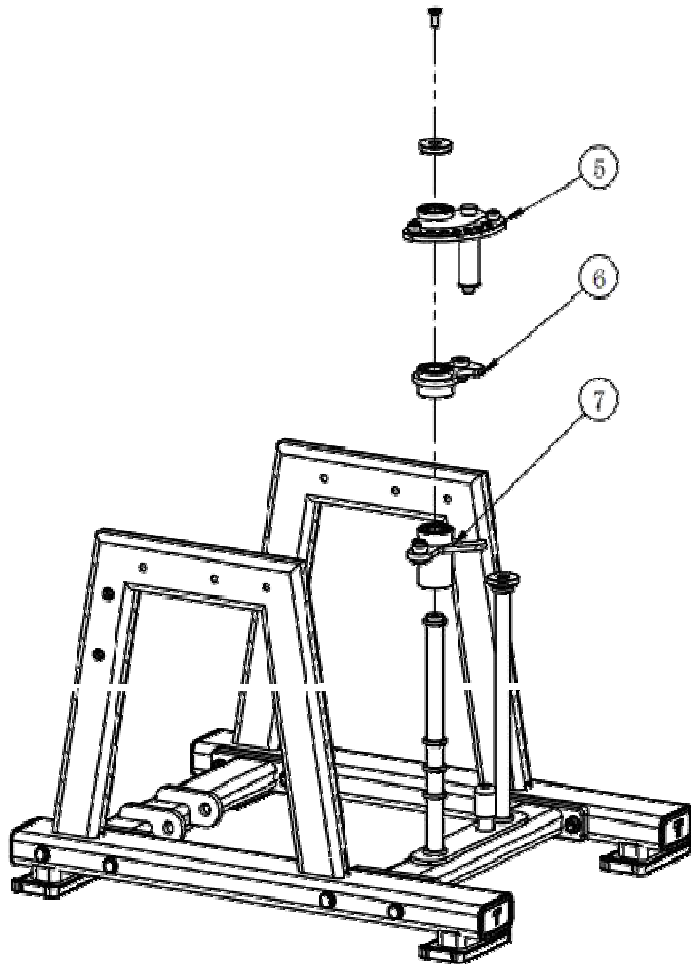

ASSEMBLY STEPS

Step	Item NO	Name	Qty
3	8	8139-1200ASSY	1
	9	8139-1300ASSY	1

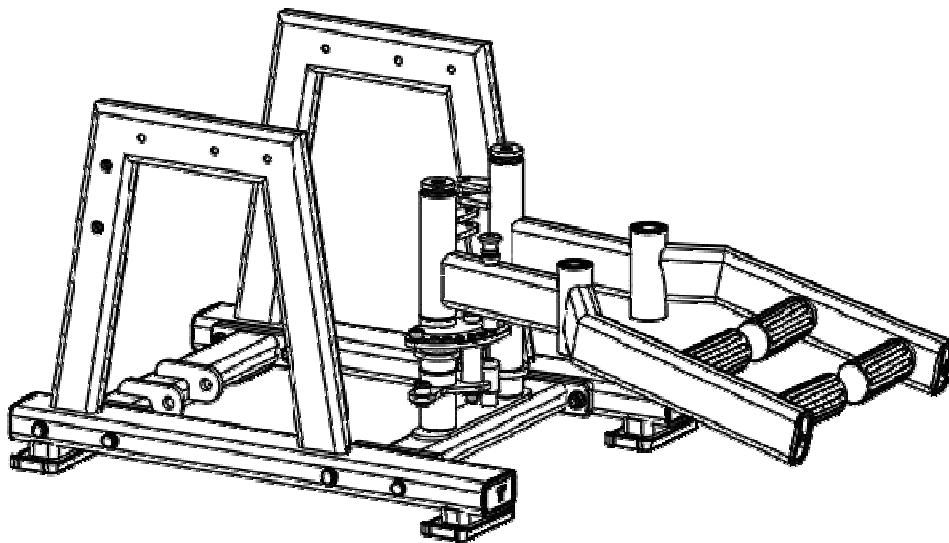
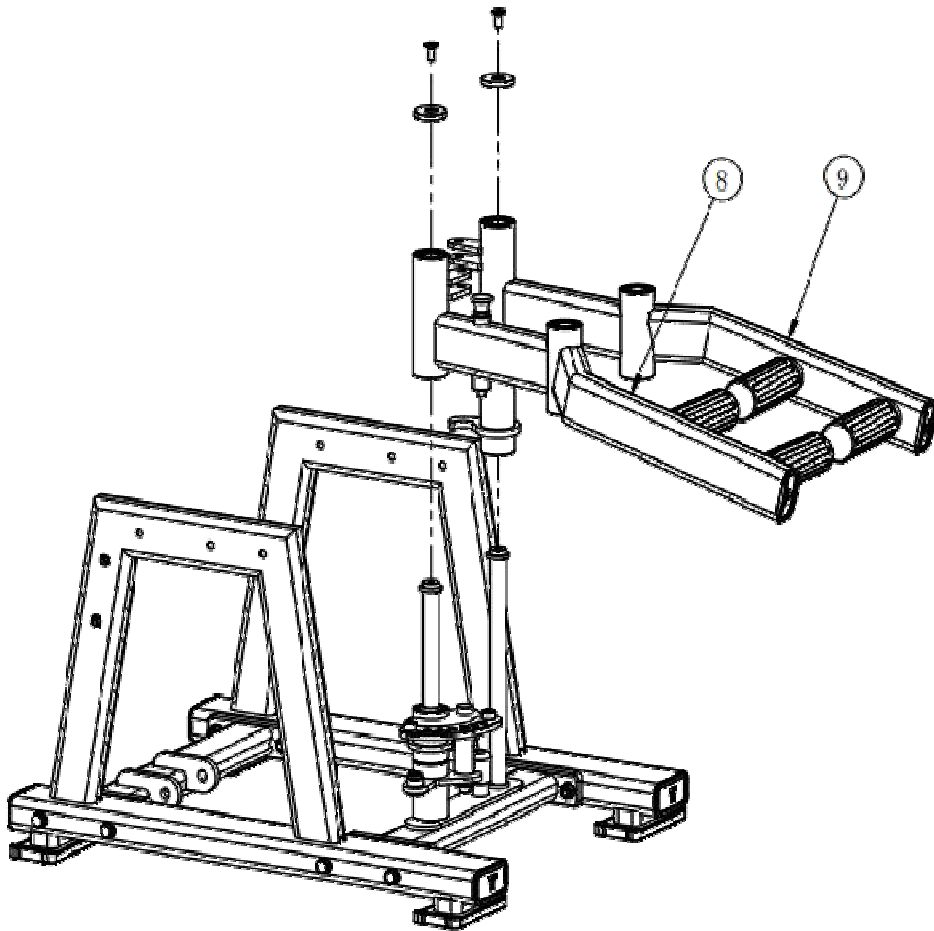

ASSEMBLY STEPS

Step	Item NO	Name	Qty
4	10	8139-0700ASSY	1

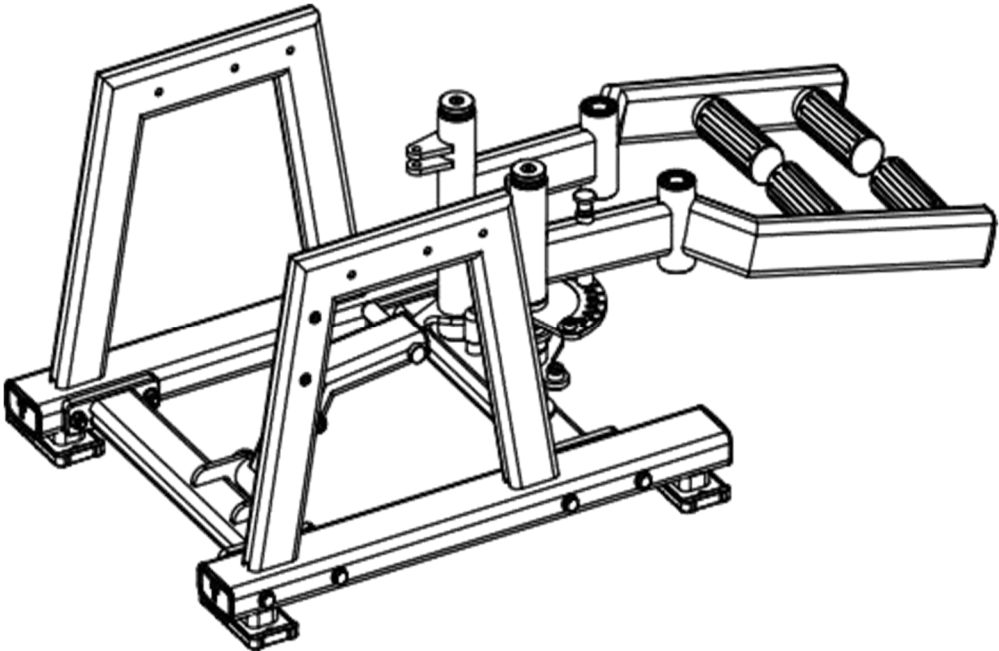
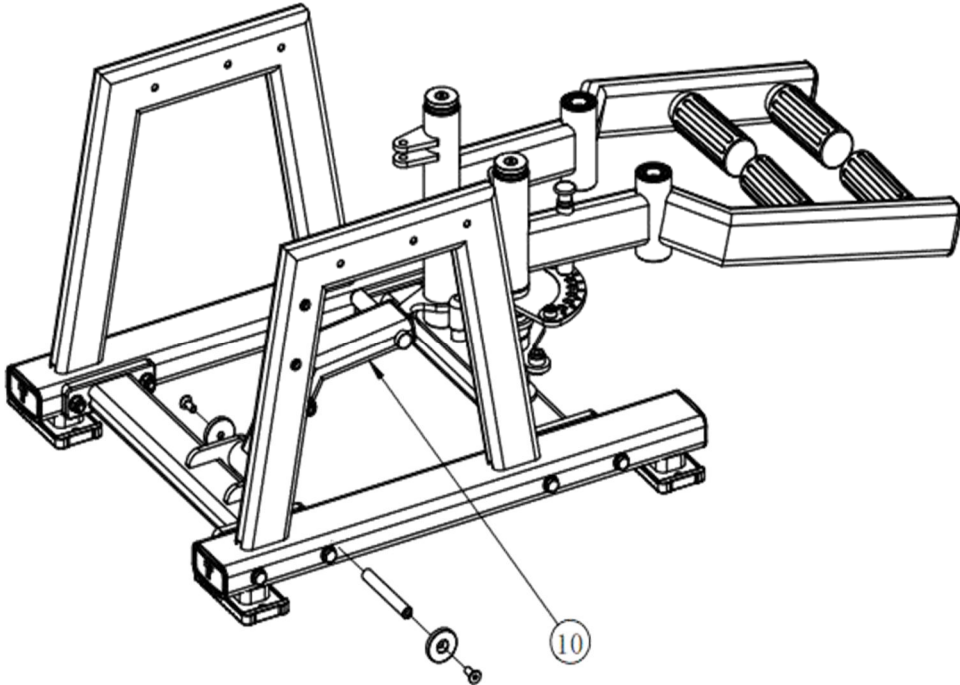

ASSEMBLY STEPS

Step	Item NO	Name	Qty
5	11	8139-1900ASSY	2
	A	IMP-GB95	4
	B	GB5780M12*30	4

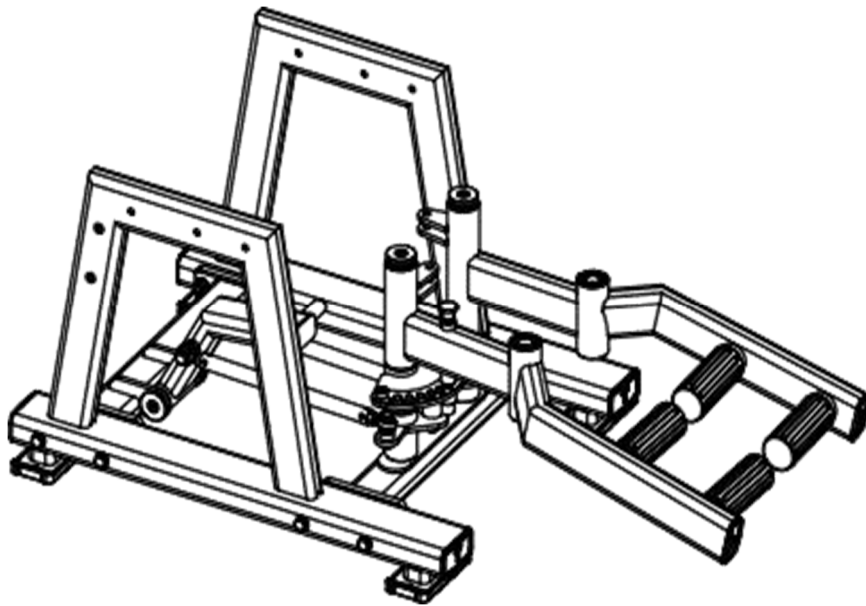
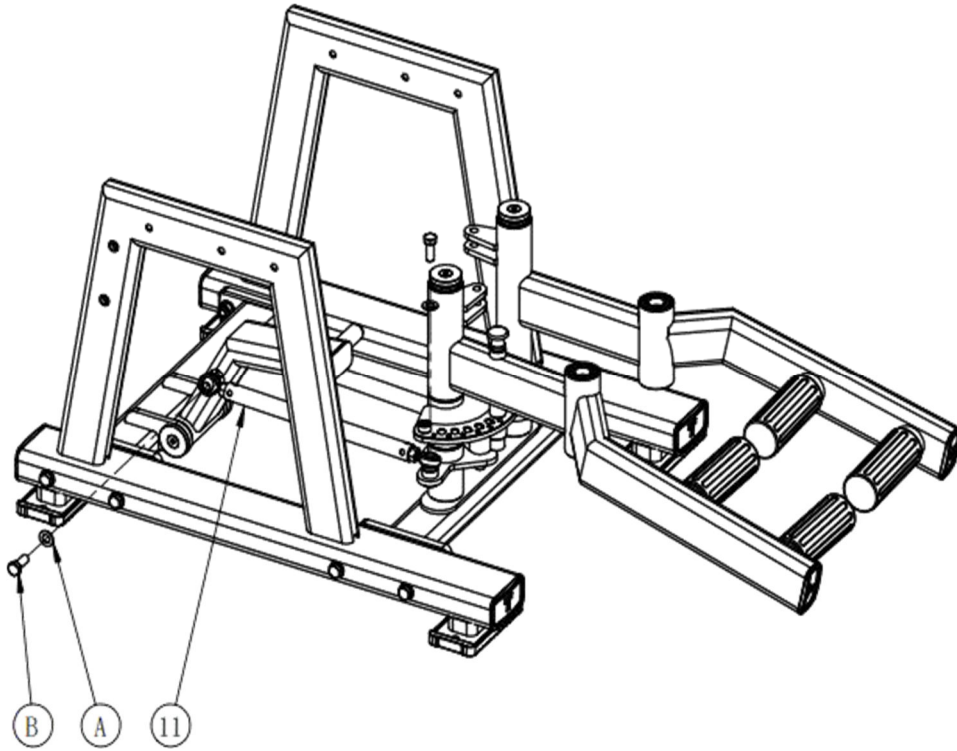

ASSEMBLY STEPS

Step	Item NO	Name	Qty
6	12	8139-0300ASSY	1

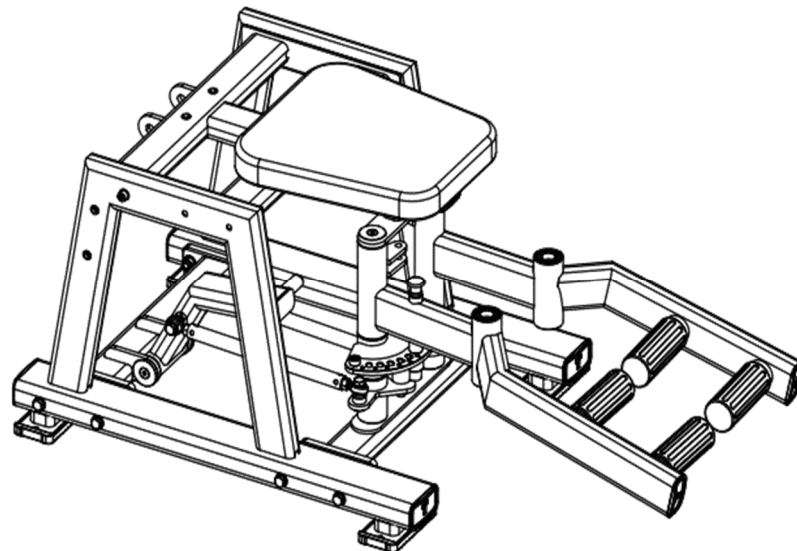
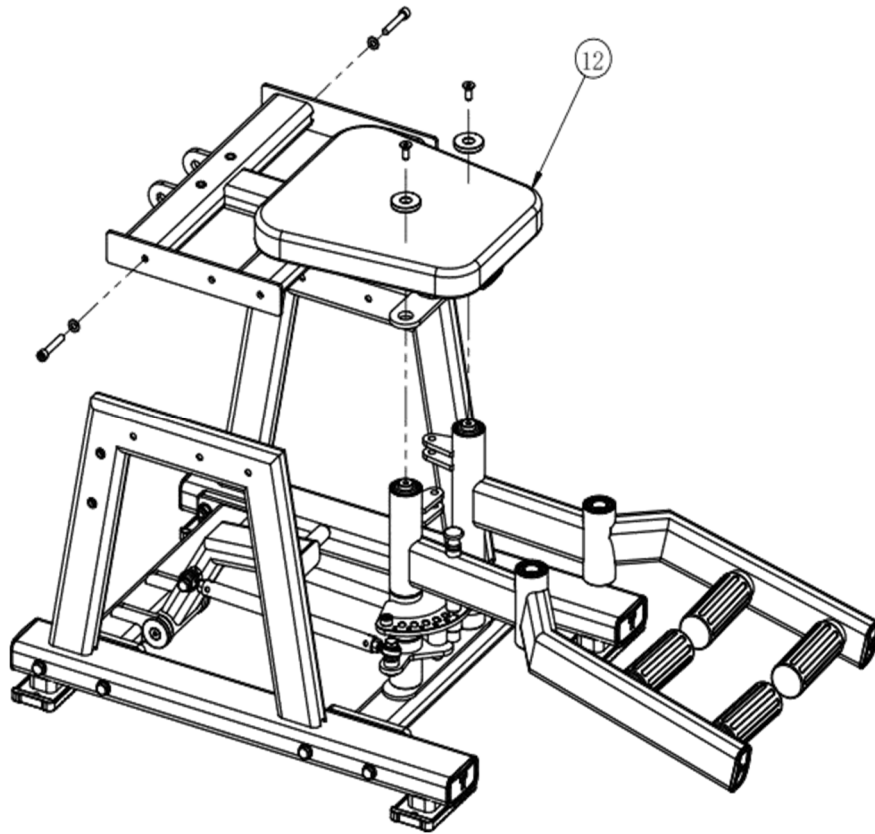

ASSEMBLY STEPS

Step	Item NO	Name	Qty
7	13	8139-0600ASSY	1

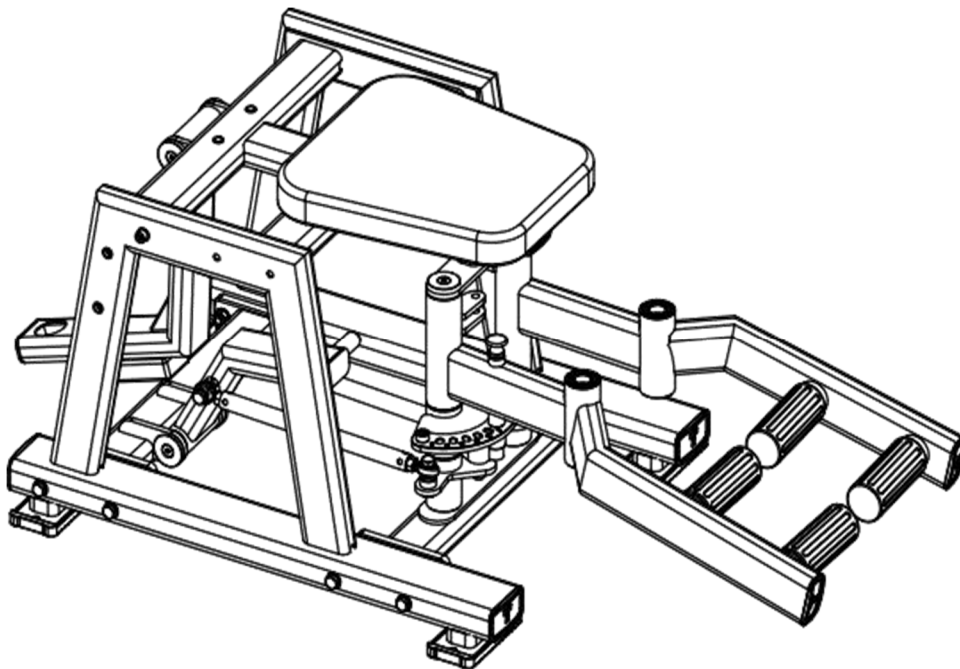
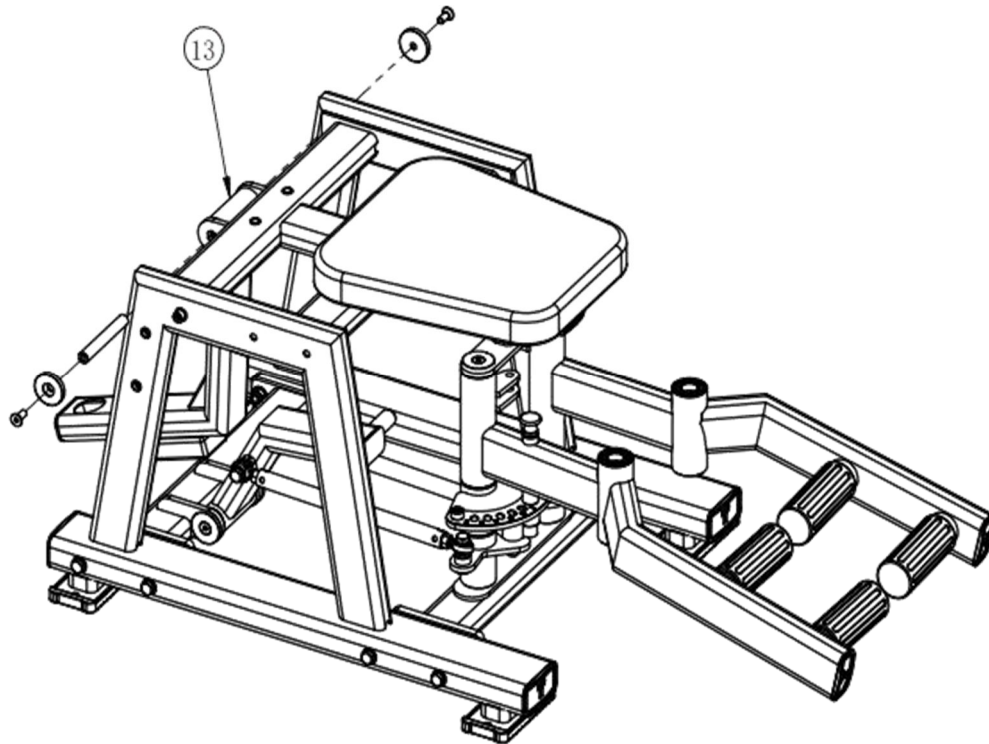

ASSEMBLY STEPS

Step	Item NO	Name	Qty
8	14	8139-2000ASSY	1
	15	8139-2100ASSY	1

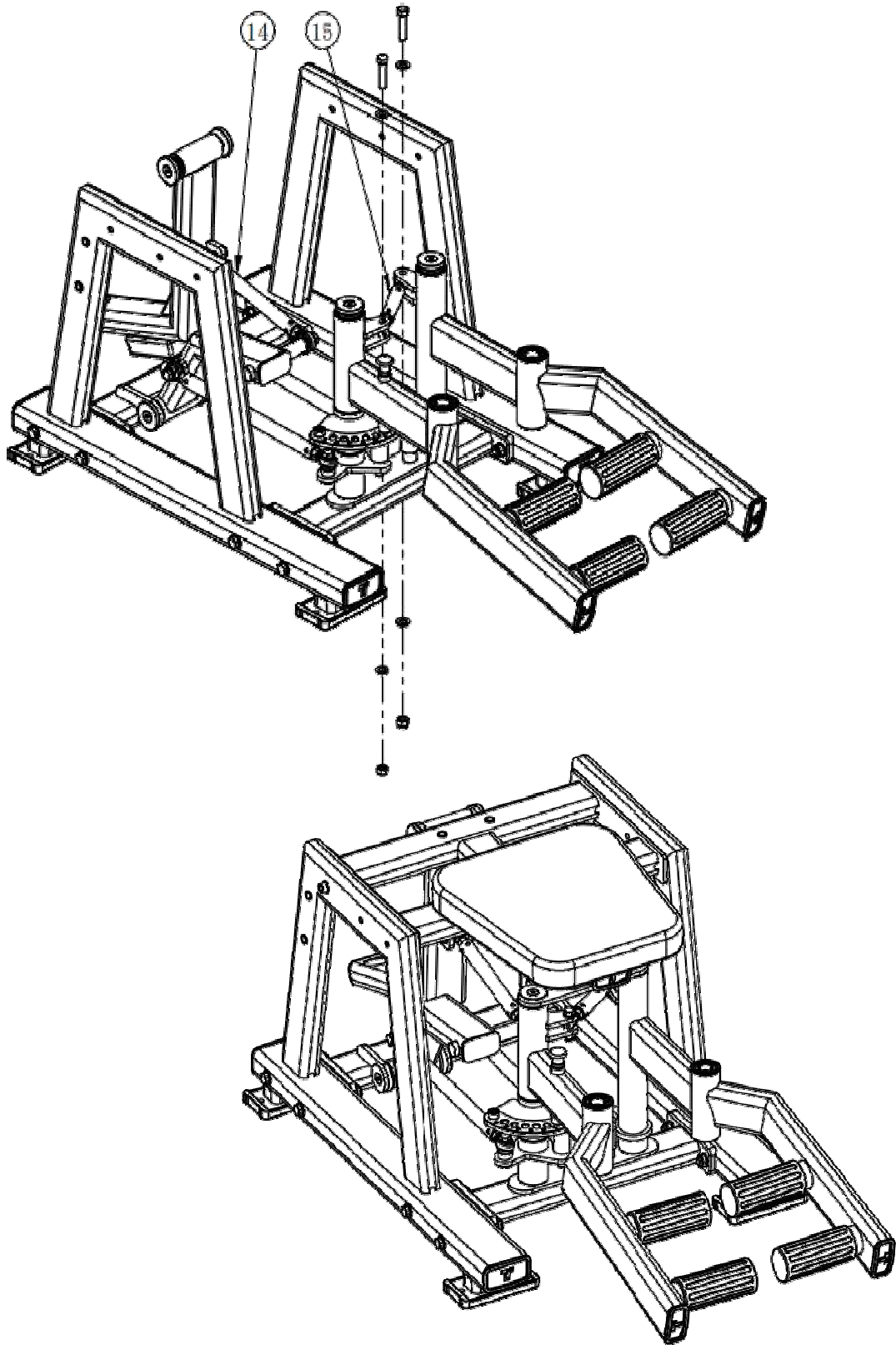

ASSEMBLY STEPS

Step	Item NO	Name	Qty
9	16	8139-0800ASSY	1
	17	8139-0900ASSY	1

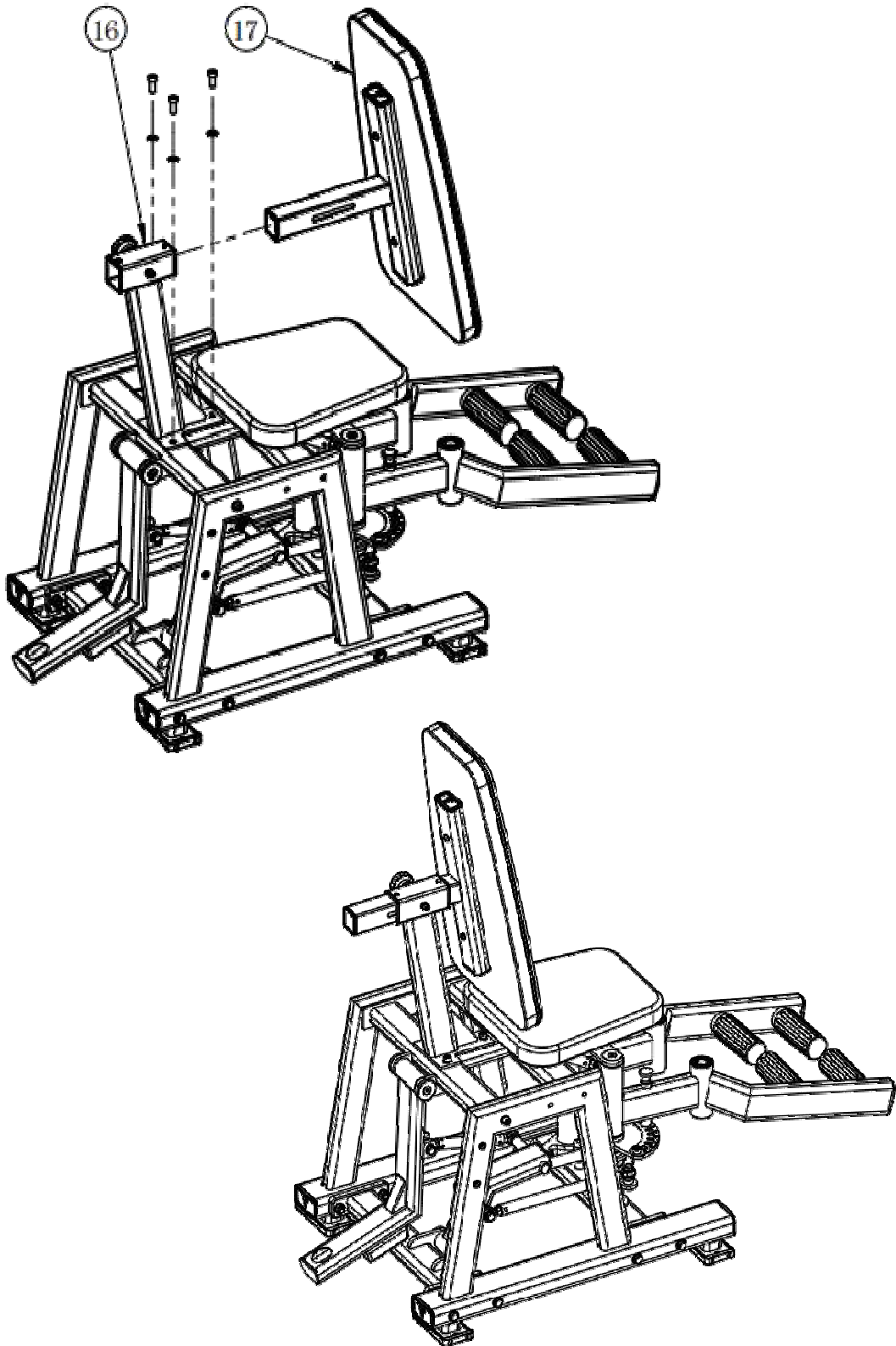

ASSEMBLY STEPS

Step	Item NO	Name	Qty
10	18	8139-1700ASSY	2

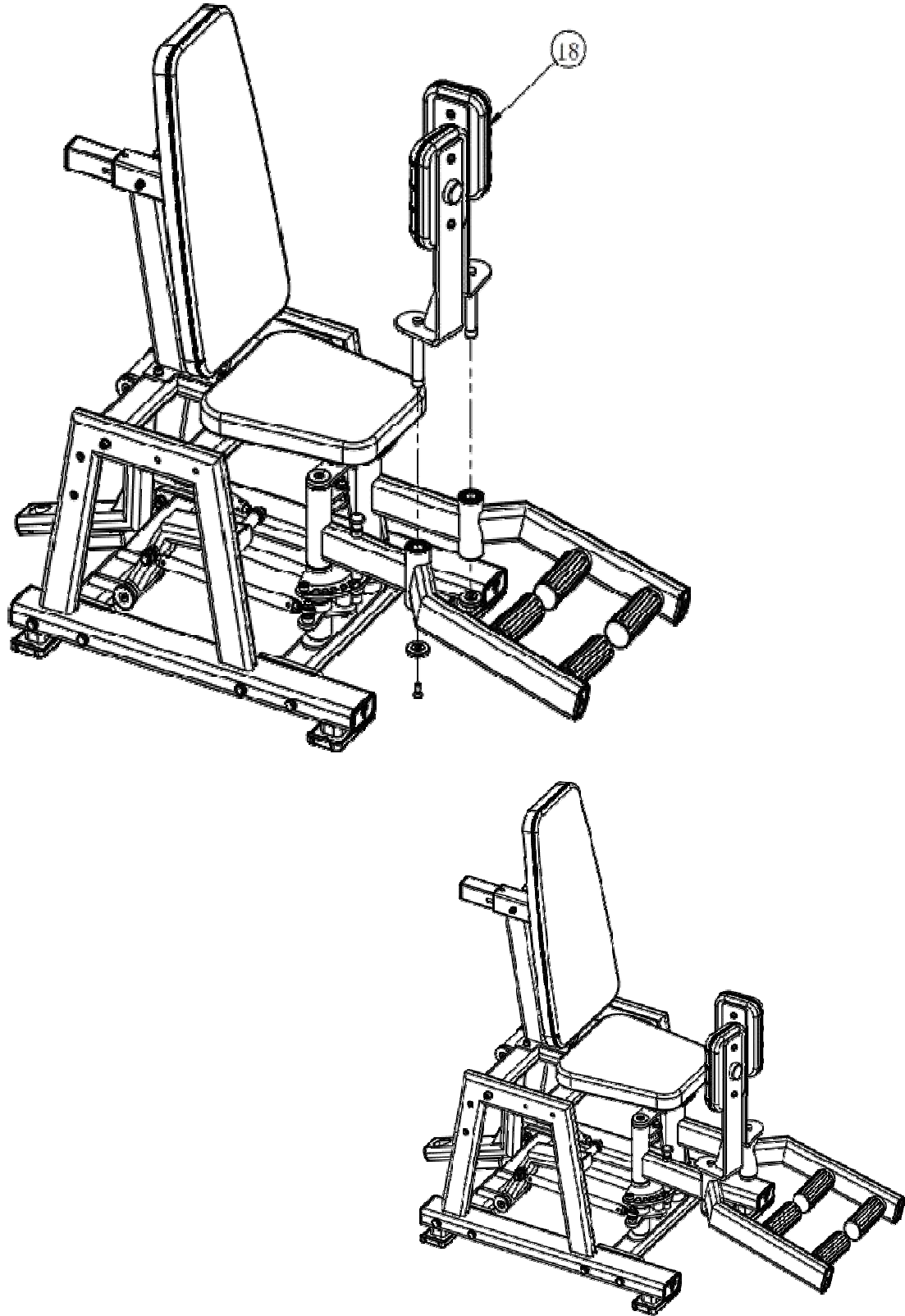

ASSEMBLY STEPS

Step	Item NO	Name	Qty
11	19	8139-1000ASSY	1
	20	8139-1100ASSY	1
	21	Q1001-32ASSY	1
	22	04-8101-1200 ASSY	2

