

FRENCH FITNESS

FF-FT500

**FRENCH FITNESS FT500
LIGHT COMMERCIAL TREADMILL**

ASSEMBLY MANUAL

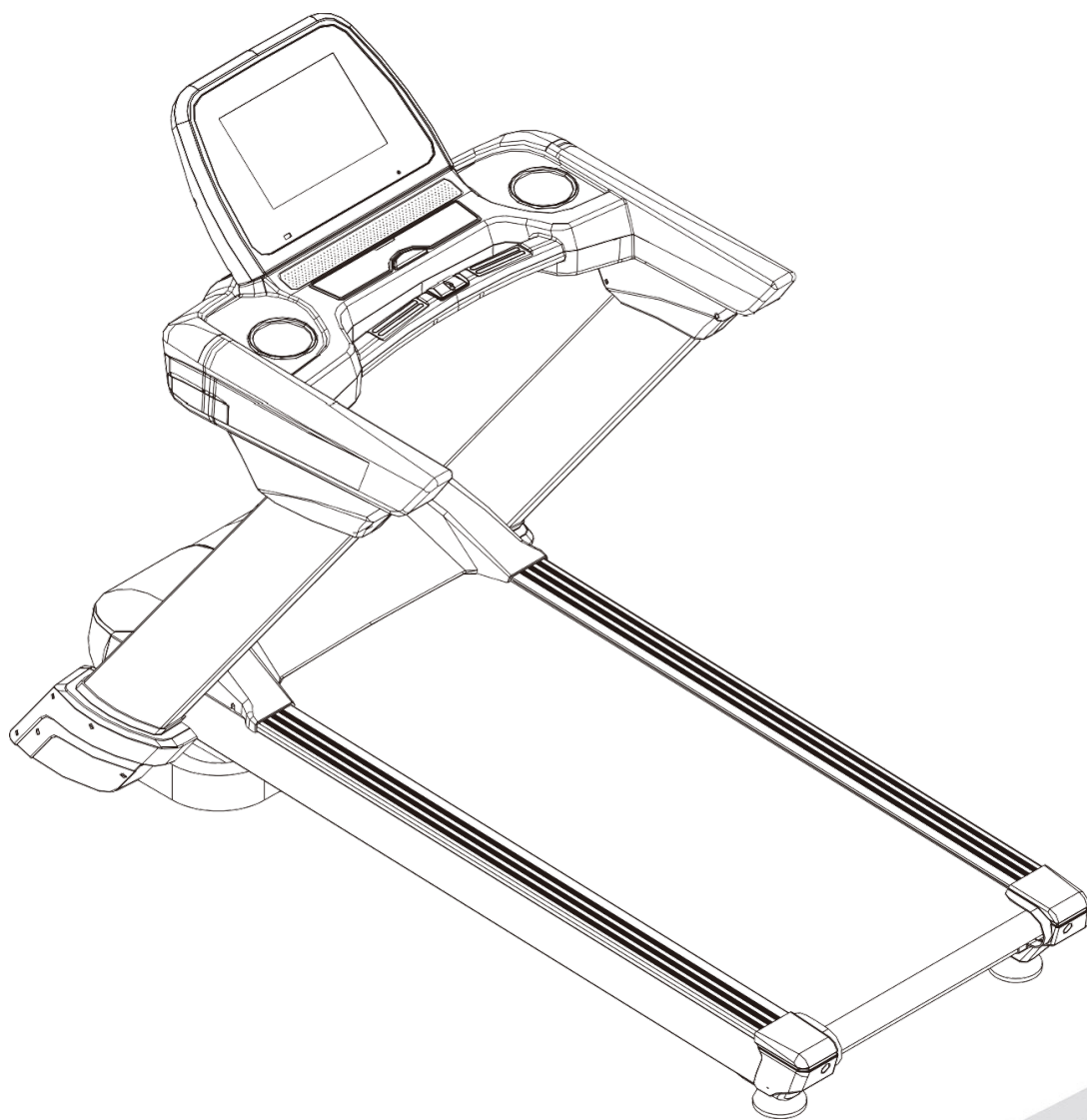

FEATURES

- Super folding
- 0.7" (18mm) Soft Running board
- Air Foot Shock Absorption: (4) Thick elastic rubber pads for premium cushioning on landing and take off
- LED
- 110 VAC 60Hz standard
- 2.5 HP Continuous AC Motor Peak: 4.0HP
- Rated Power: 1800W/h
- Rated HZ: 50/60 Hz
- Display Readouts: Incline (%), Speed (km/h), distance (km), calories (kcal), heart rate (bpm), time
- MP3 (Headphone) port: YES
- USB Port: Yes
- Touch Heart Rate Hand Grips
- Speed range: 0.62 - 12.9mph (1-20.7 km/h)
- Incline: 0-10%
- Step-Up Height: 8"
- Running Belt: 22.8" x 62.9" (580mm x 1600mm)
- California Residents see Prop 65 WARNINGS

TECH SPECS

- Max User Weight: 330lb (150kg)
- Weight: 313lb (142kg)
- Dimensions: 82"L x 41"W x 54"H (210.6cm x 106cm x 139cm)

WARRANTY

10 Years Parts, 1 Year Labor (Light Commercial)

CONTENTS

Item	Page
1. Safety Instruction	4
2. Special Safety Instruction	5
3. Configuration List	6
4. Explosion Diagram	8
5. List of Explosion Diagram	9
6. Steps of Assembly	11
7. Structure of Finished Product	13
8. Operating Instruction of treadmill	15
9. Operating Instruction of Instrument	17
10. Description of Program	24
11. Fault Analysis and Handling	27
12. Daily Maintenance	28
13. Important Matter	31

1. SAFETY INSTRUCTION

Thank you for purchasing this product. It will improve your health.

Many safety problems are considered in design and manufacturing of the product, but please still operate according to the instruction below just in case. We are not responsible for any consequences caused by abnormal operation.



In order to ensure your safety and prevent accidents, please carefully read the operating instruction before use.

1. Please consider your physical condition when training with the product, and train in an appropriate and regular way to ensure that you have enough physical strength. Wrong or excess training will be harmful to your health.
2. This product is unsuitable for children. Those that feel unwell or are mentally defective and lack common sense of use shall not use the product unless under guardianship or guidance of people responsible for their safety. Children shall be prevented from fiddling with the equipment.
3. This product is suitable for Semi commercial use condominium, corporate office, etc.
4. Heart rate display of this product does not provide data for clinical medicine.
5. The damaged power line must be replaced by manufacturer or professional maintenance personnel to prevent danger.
6. Please inspect all components and ensure that screws and nuts are tightened before use.
7. Please wear comfortable tight clothes when using the product to prevent the clothes from being hooked by the machine. Don't let kids or pets play nearby to avoid accidents.
8. Please place the product on smooth, clean and flat ground, ensure that there is nothing sharp nearby and don't use it near source of water and heat.
9. Don't touch any moving parts with hands or place hands or feet in gap beneath the running belt.
10. This product can only be used by one person when running.
11. Ensure that screws and bolts are tightened after assembly of the product.
12. Please use accessories provided by the factory and don't replace them without permission.

2. SPECIAL SAFETY INSTRUCTION

Power source

- Place the treadmill where the plug can reach the socket.
- Directly insert the power line into socket and keep it firm.
- Please use qualified socket to avoid consequential danger. If the plug and socket are incompatible, ask the electrician to deal with it instead of moving the plug.
- 220V—240VAC power source is used.
- Please keep power line away from roller, and don't place power source on running belt or use damaged plug.
- Please pull the plug out from the socket before cleaning and maintenance.

Warning: failing to pull out the plug may cause personal injury and damage to equipment.

- Please inspect each component before use.
- Please don't use the product outdoors, at high humidity and in the sunshine.
- Please turn off the machine and pull out the plug when leaving.

3. Description of Assembly

- Please carefully read steps of assembly before assembly.
- Take out all wrappings and place them on clean ground, which is convenient for you to check and install.
- Carefully check whether components are complete according to packing list.
- Please pay attention to safety when using tools or handling. Please don't install forcibly as you like in assembly.
- Please confirm whether the tools and packing materials left are dangerous. Plastics and foam are harmful to kids.
- Assemble the product according to the instruction. Please carefully read steps and description of assembly.
- The product must be carefully installed by adults, and by professionals if necessary.

Warning: carefully install the product without damaging it

3. CONFIGURATION LIST

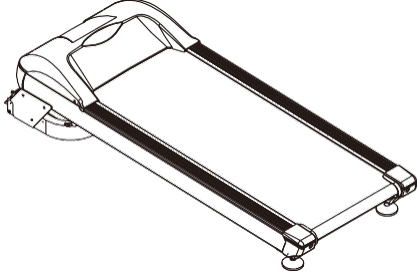
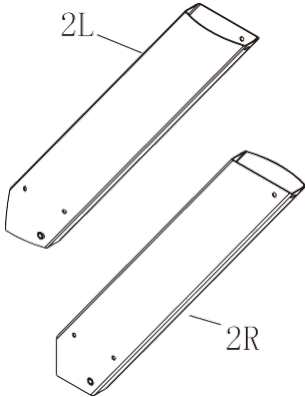
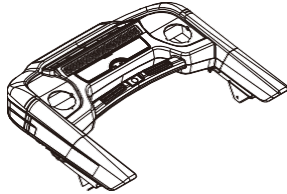
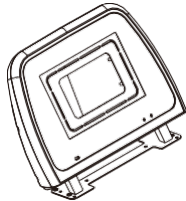
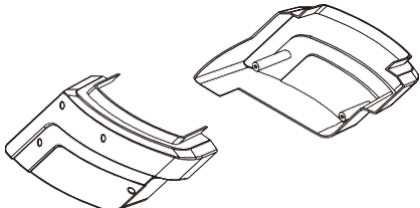
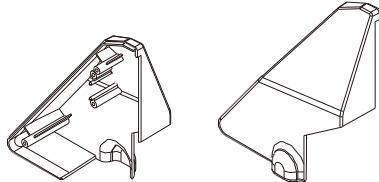
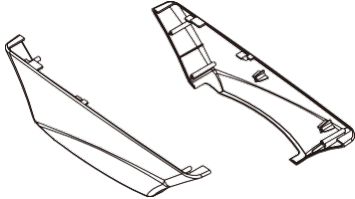
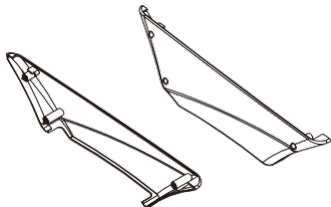
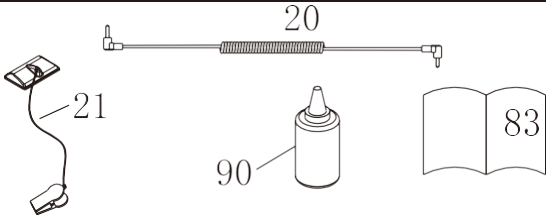
<p>Main frame</p>		<p>Left and right columns</p>	
<p>Electronic meter stand</p>		<p>Panel</p>	
<p>Left and right side covers</p>		<p>Left and right inner covers</p>	
<p>Outer cover on column</p>		<p>Inner cover on column</p>	
<p>Bag of instruction</p>	<p>21# safety switch 20# MP3 connecting line 90# silicone oil 83# instruction</p>		

rew bag

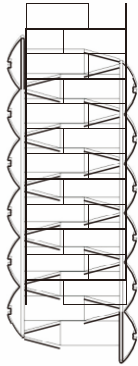

57# wrench M6 1PCS

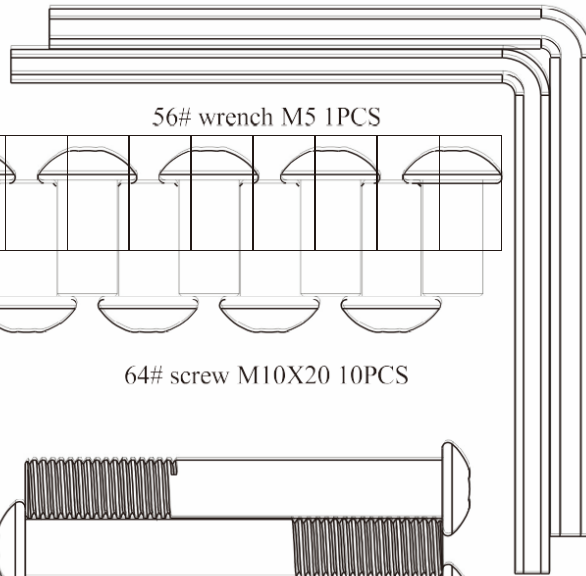

56# wrench M5 1PCS

64# screw M10X20 10PCS

79# screw ST4.2 X 15 12PCS

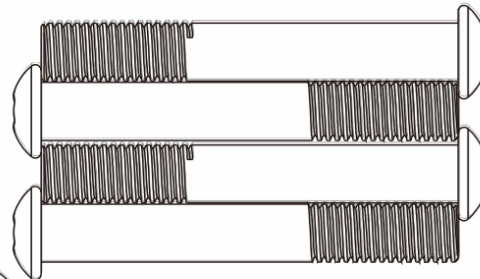
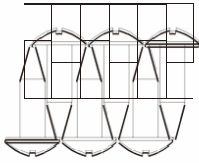

80# screw ST4.2 X 15 6PCS

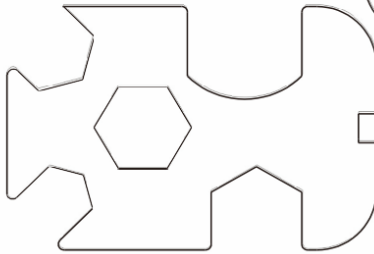

60# screw M10X80 4PCS
58# cross wrench 1PCS



68# wrench 1PCS

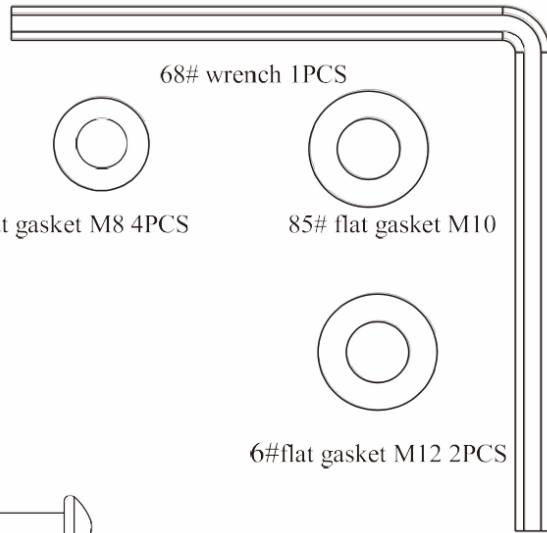

84# flat gasket M8 4PCS

85# flat gasket M10

74# screw M8X15 4PCS

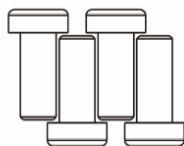

6# flat gasket M12 2PCS

84#screw M12X80 2PCS

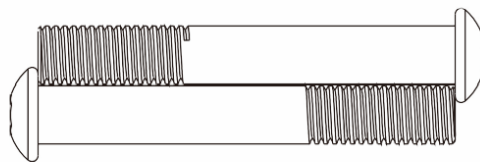

4. EXPLOSION DIAGRAM

All accessories are here and displayed in the list below.

The above parts list is list of the highest configuration of this series of products.

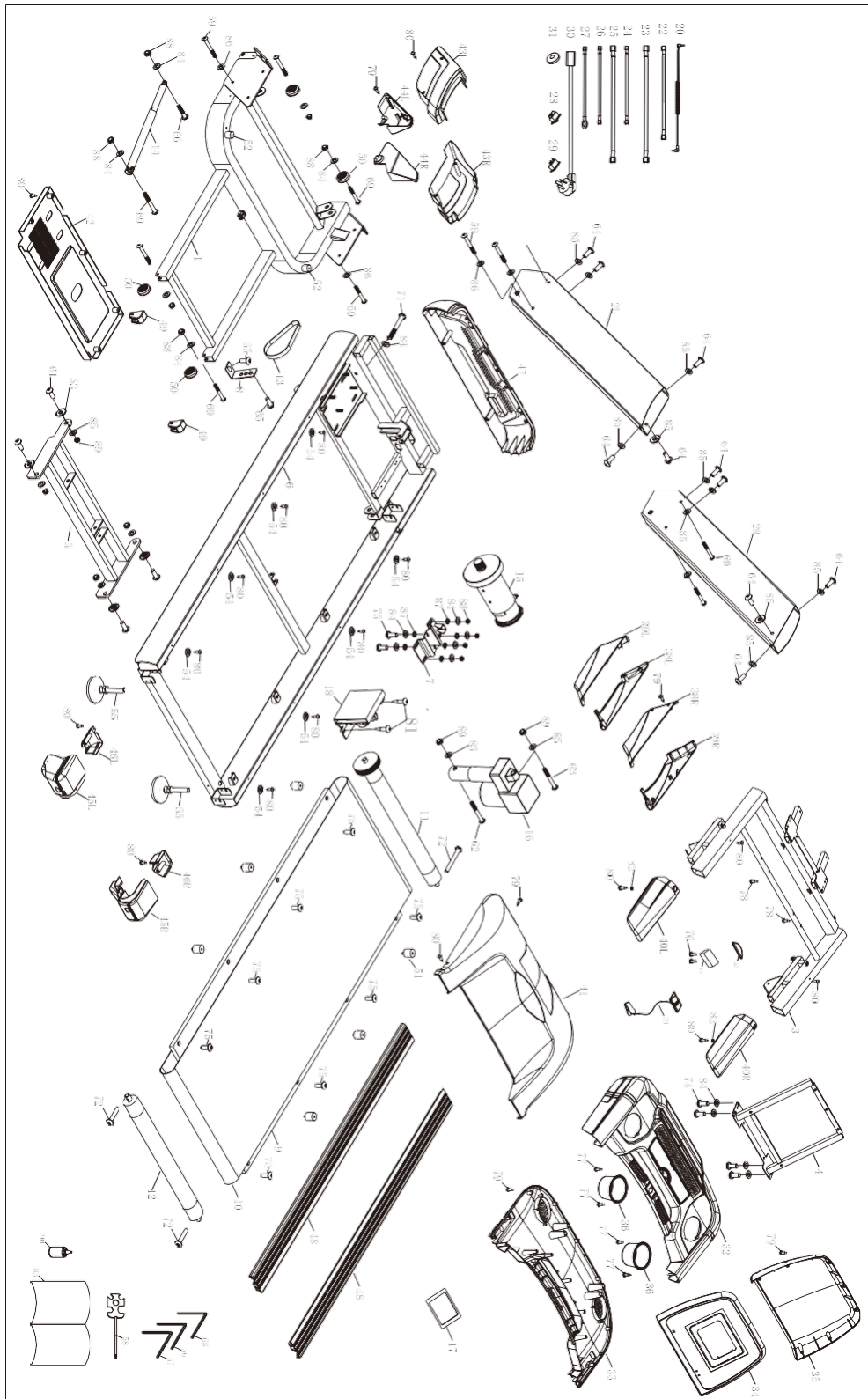

5. LIST OF EXPLOSION DIAGRAM

Serial	Name	Quanty	Serial	Name	Quantity
1	Pedestal	1	33	Protecting cover on column	1
2	Left column	1	34	Left foamed armrest	1
3	Right column	1	35	Right foamed armrest	1
4	Electronic meter stand	1	36	Upper cover of motor	1
5	Ascension frame	1	37	Lower cover of motor	1
6	Main frame	1	38	Left side cover	1
7	Motor support	1	39	Right side cover	1
8	Support of massager	1	40	Rear angle bead	One of each side
9	Package stator	1	41	Front protecting cover of motor	1
10	Running board	1	42	Plastic edgestrip	2
11	Running belt	1	43	Adjusting foot pad	1
12	Front roller	1	44	Rubber gasket	
13	Rear roller	1	45	Moving roller bush	2
14	Belt	1	46	Moving roller	2
15	Gas spring	1	47	Decorative cover of handle	
16	DC motor	1	48	Round cushion pad	
17	Ascension motor	1	49	Adjusting foot pad	
18	Massage head	1	50	Square inner tube plug	
19	Upper control of electronic	1	51	Round inner tube plug	
20	Controller (lower control)	1	52	Sponge sheath	
21	Grip pulse	1	53	Body twister	
22	Remote controller	1	54	Power line buckle	
23	MP3 connecting line	1	55	Plastic spacer	
24	Safety lock	1	56	Edgestrip buckle	8
25	Upper line of electronic meter	1	57	Compression spring	
26	Middle line of electronic meter	1	58	M5 L - shaped hexagon	
27	150 branch line	1	59	Cross open-end wrench	1
28	300 single line	2	60	Half-round head hexagon socket head cap screw	
29	150 single ground line	2	61	Cylinder head hexagon socket head cap screw	
30	Power switch	1	62	Countersunk head hexagon socket head cap screw	
31	Upsidedown T-shaped socket	1	63	Cross recessed pan head self-tapping screw	
32	Power line (with tail plug)	1	64	Cross recessed pan head self-drilling screw	

65	Magnet ring	1	90	Flat gasket	17
66	Top shell of electronic meter	1	91	Spring washer	6
67	Panel of electronic meter	1	92	Locknut	12
68	Lower cover of electronic meter	1	93	Silicone oil	1
69	Iron horn hood		94	Instruction	1
70	Hook foam				
71	Audio line				
72	M8				
73	Kettle seat	2			
74	Protecting cover on column (inner)	1			
75	Protecting cover on column (outer)	1			
76	Side cover				
77	Inner cover				
78	Lower cover of rear angle bead				
79	One on each side				
80	Red round cushion pad				
81	Black round cushion pad				
82	Powder metallurgy bush				
83	Middle line of electronic meter				
84	Upsidedown T-shaped socket				
85	Lower cover of panel				
86	Trim strip				
87	Left and right rear angle beads	1			
88	Grip pulse + ascension/switch				
89	Grip pulse + speed shortcut key				

6. STEPS OF ASSEMBLY

Step 1: installation of complete machine

1. Hold the electronic meter and slowly lift it to fixed screw hole.
2. Fix electronic meter onto column with 70# screw and 87# flat gasket.
3. Fix protecting cover of column onto rear cover of electronic meter on the top of column with 82# screw.

Fix column onto pedestal with 70# screw, 76# screw and 87# flat gasket.

Then remove package stator (red) fixing frame and pedestal, and prevent the frame from hurting people when bouncing off.

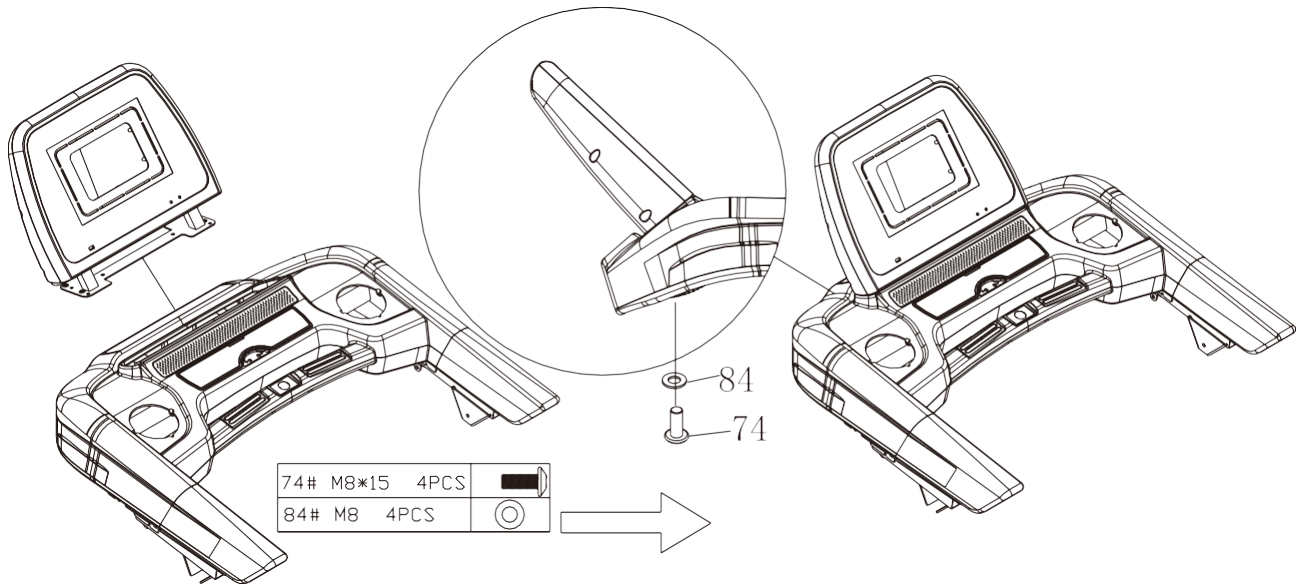

Step 2: assembly of left and right side covers

1. Fix the left and right side covers on both sides of pedestal with 84# screw and lock them.

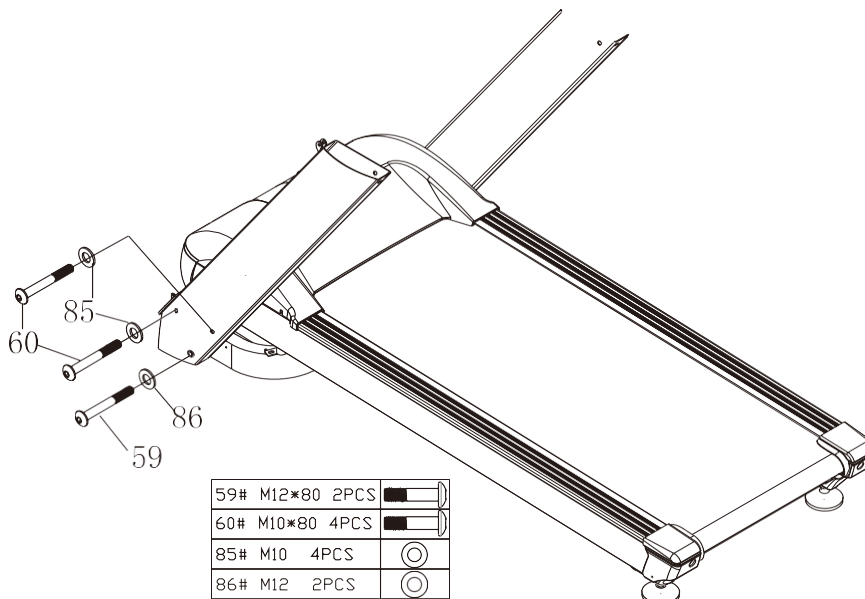

Step 3:

1. Take out support of massager, pay attention to (R) indication of (L) gasket, and fix support of massager onto left and right stand pipes with 70# screw and 87# flat gasket.
2. Take out supine support, and fix supine support onto support of massager with 72# screw and 87 flat gasket.
3. Fix massager onto stator on the top of supine support with hex screw, flat gasket and spring washer.

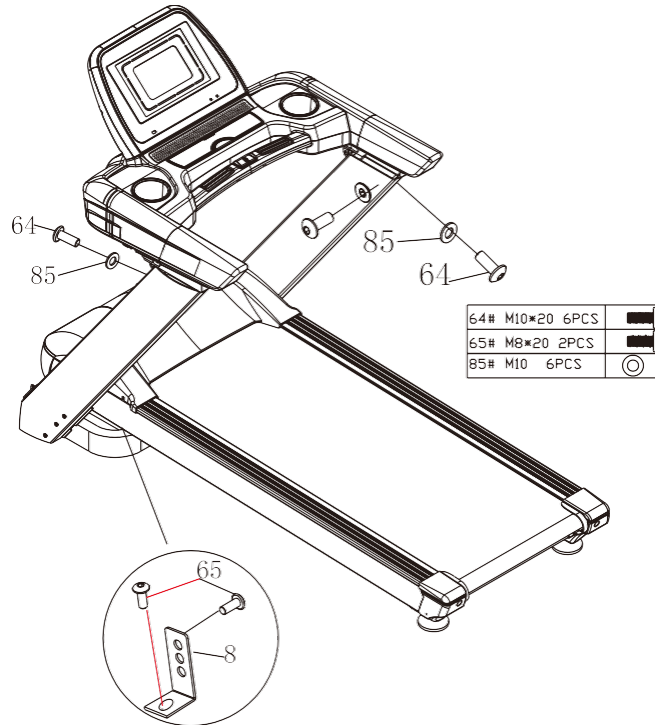

Step 4:

1. Install dumbbell onto groove on supine support in the figure;
2. The body twister can be placed at any stable position by the user;
3. Safety lock is placed at yellow position on electronic meter;
4. Massage belt is hung in grooves on both sides of massager.
5. Finally, please ensure that all screws are tightened after all accessories are assembled.

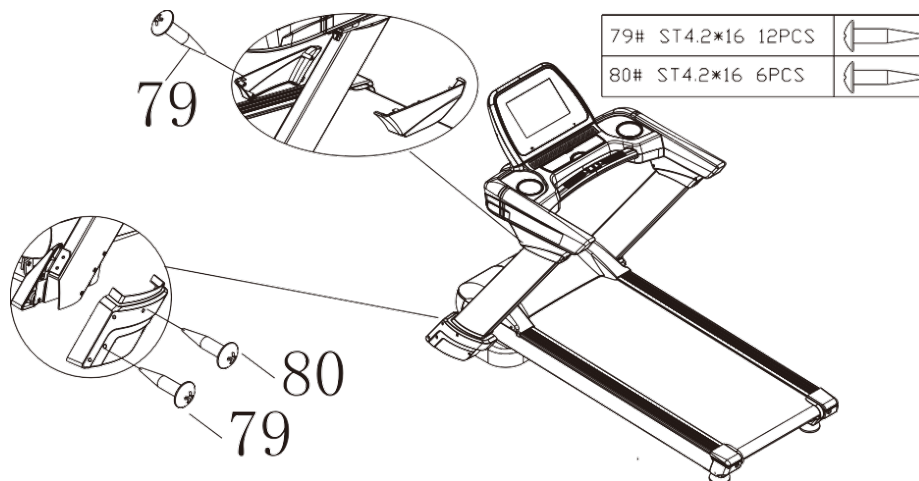

7. STRUCTURE OF FINISHED PRODUCT

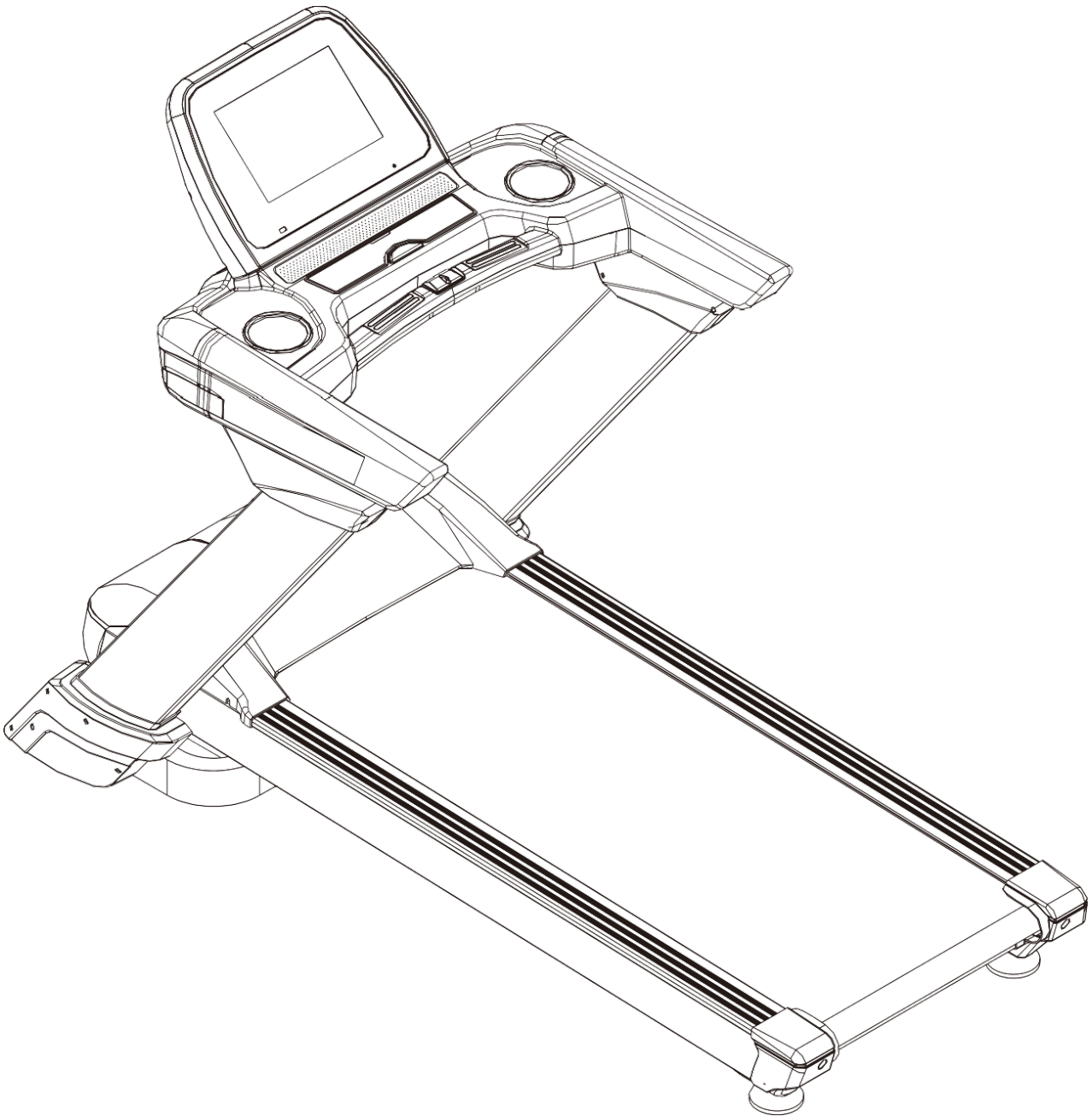

Description of movement of treadmill:

1. Fix one side of pedestal with a foot, and pull the armrest backward with hands to make the treadmill tilt backward after folding it.

2. Move the machine.

Please move the machine to a place inaccessible to kids to prevent them from touching the gas spring casing to make the running platform fall to cause unnecessary accidents.

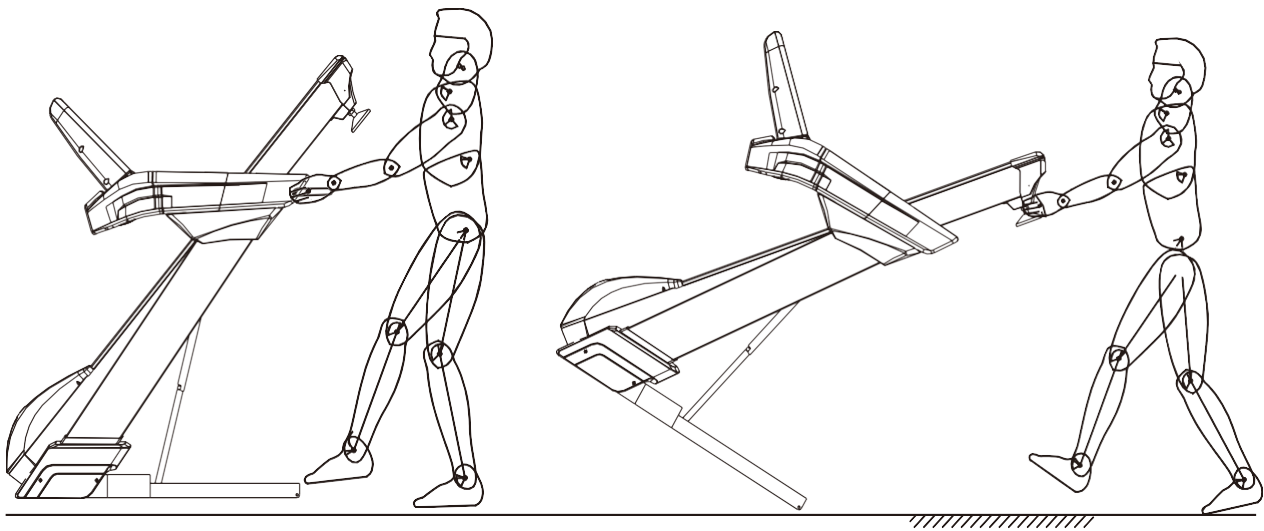

8. OPERATING INSTRUCTION OF TREADMILL

Power socket with ground line must be used for your safety when you use the treadmill.

1. Insert power plug into socket and turn on power switch a (light turns red). You will hear “beep” and window on instrument panel displays;
2. Place safety lock at yellow position of instrument panel, when the treadmill can be normally used. Please clamp the safety lock onto your clothes when using the machine to avoid accidents. You can open the safety lock at any time to immediately stop the motor to avoid falling over. Please place the safety lock back and start starting program to use the machine again.

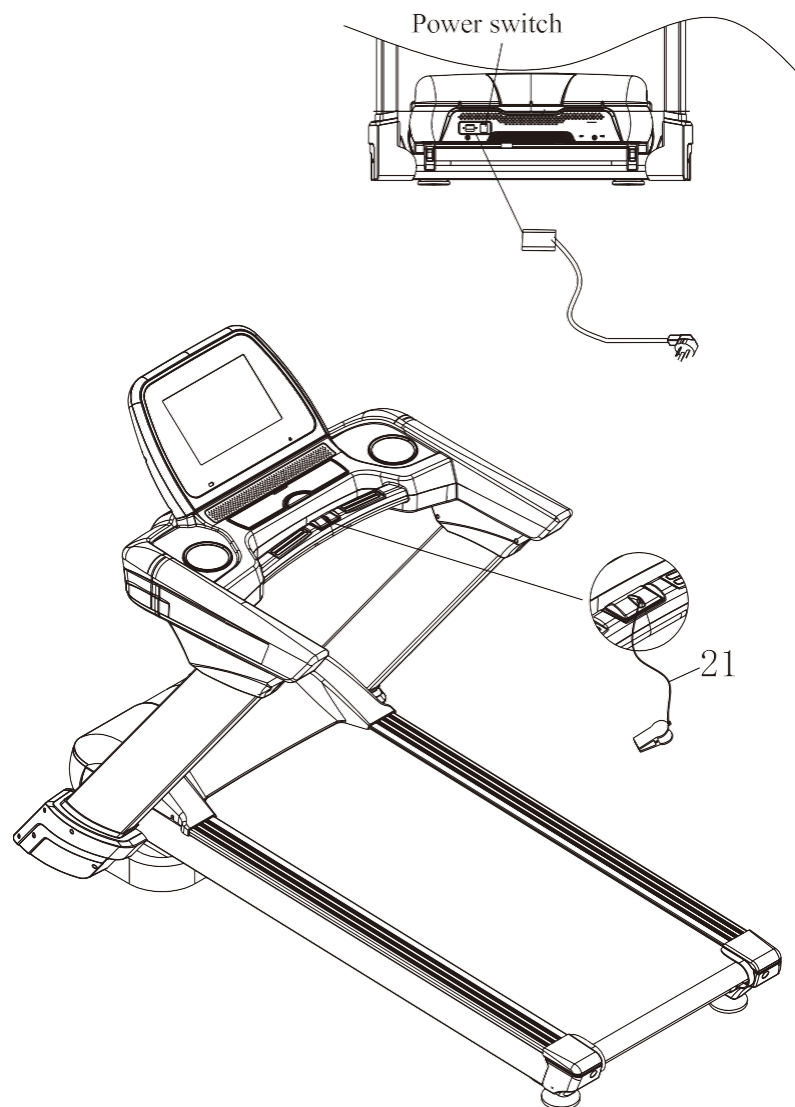

Description of folding:

•Fold the treadmill:

Folding the treadmill can save space.

Turn off the power switch and pull out the power plug before folding.

Lift the running platform with hands until it is stuck by gas spring casing.

•Lower the running platform:

Gently tread the gas spring casing as shown in the figure, the running platform will slowly fall to the ground.

Note: keep kids away when operating this step to prevent injury.

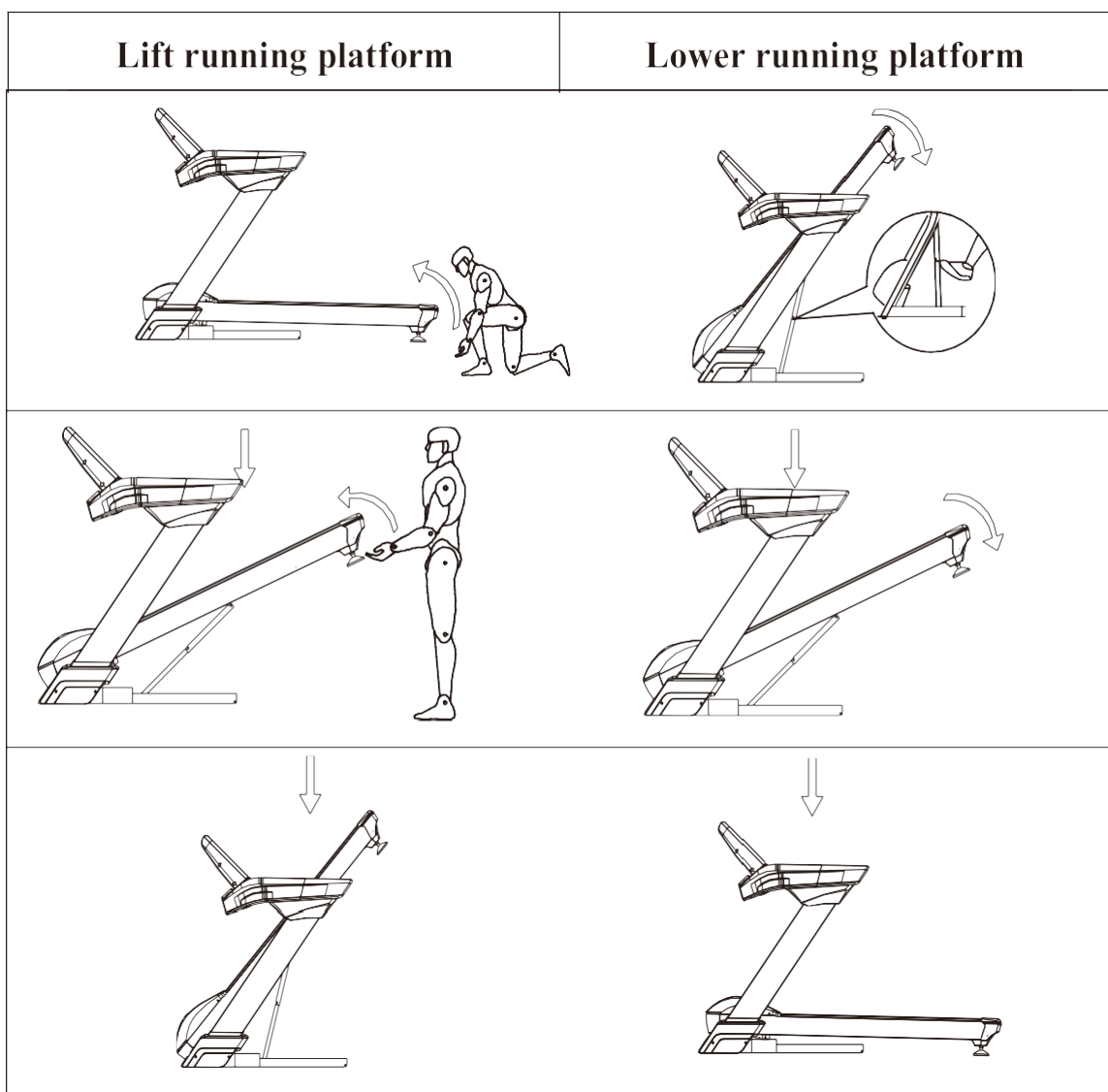



I. Parameter Specification

Motion Parameters under different running modes:

- Lowest speed displayed: 1 km/h
- Highest speed displayed: 25 km/h
- Longest running time under TIME MODE: 99 mins
- Shortest running time under TIME MODE: 8 mins
- Longest running distance under DISTANCE MODE: 99 km
- Shortest running distance under DISTANCE MODE: 1 km
- Largest calorie consumption under CALORIE MODE: 990 cal
- Smallest calorie consumption under CALORIE MODE: 20 cal
- Shortest running time of P01-P12 automatic program: 8 mins
- Longest running time of P1-P12 automatic program: 99 mins
- Lowest incline displayed: section 0
- Highest incline displayed: section 0-10% (18 Levels)

II. Specification on Display Window of Electronic Meter

Content displayed on electronic meter:

SPEED window: 1. Display speed when running
 2. When automatic program is set, display corresponding speed of section

TIME window: 1. Display running time when running
 2. When automatic program is set, display the set running time
 3. When fat rate test is set, display all parameters set

DISTANCE window:

1. Display running distance when running
2. When automatic program is set, display the serial number of the program

CALORIE window:

1. Display calories consumed when running

HEART RATE window:

1. Display the corresponding heart rate when both hands grasp the heartbeat sheet steel

INCLINE window:

1. Display the running incline when running
2. When automatic program is set, display the corresponding incline of section 1

LATTICE window:

1. Display 400-meter-long annular runway under full-manual operation mode
2. When automatic program is set, display corresponding speed program graph; after startup, circularly display program graph of speed and incline. Current motion section speed or incline graph blinks.
3. When safety key is disconnected, display: SAFETY KEY DISCONNECTED
4. When quick stop switch is on, display: QUICK STOP OPEN
5. During fat rate test, display: FAT RATE TEST
6. When inputting gender, display: MALE
7. When inputting age, display: INPUT AGE
8. When inputting height, display: INPUT HEIGHT
9. When inputting weight, display: INPUT WEIGHT
10. When starting fat rate test, display: FAT TEST, PLEASE WAIT

III. Functional Specifications on Keys

1. Functional keys on keyboard plate:
 - Speed shortcut: 3 (4, 8, 12)
 - Incline shortcut: 3 (4, 8, 12)
 - START key STOP key
 - PROG key MODE key
 - PREV key NEXT key
 - Volume + key Volume - key
 - Speed + key Speed - key
 - Incline + key Incline - key

IV. Specification on Functions and Operation of Keys

- START— functional description: starts motor Operation instruction:
 1. This key may start motor when electronic meter is under full-manual operation mode
 2. This key may start motor when electronic meter is under countdown mode
 3. This key may start motor when electronic meter is under automatic program mode
- STOP— functional description: stops motor Operation instruction:
 1. This key may stop motor when electronic meter is on
 2. When the motor comes to a full stop, all data are reset. Switch to full-manual operation mode.

- **PROG**— functional description: selects automatic program and FAT Operation instruction:
 1. This key may access to setting of automatic program when electronic meter is under full-manual operation mode
 2. After under automatic program setting, fat rate test setting may be available if continue to use this key.
 3. Operation process: automatic program setting —fat rate test setting — Full-manual operation mode

- **MODE**— functional description: selects countdown mode
Operation instruction:
 1. This key may access to setting of countdown mode when electronic meter is under full-manual operation mode
 2. This key may be used to set next parameter under fat rate test setting mode
 3. Operation processes in standby: Time countdown- Distance countdown- Calorie countdown- Full-manual operation mode
 4. Operation processes under fat rate test setting: Set gender— Set age— Set height— Set weight— Fat rate test

- **SPEED +/-** — functional description: Adjust speed when running and parameter values under parameter setting
Operation instruction:
 1. May adjust the running speed when electronic meter is on
 2. May adjust parameter values set when under parameter setting

- **INCLINE +/-** — functional description: Adjust incline when running and parameter values under parameter setting
Operation instruction:
 1. May adjust incline when electronic meter is on
 2. May adjust parameter values set under parameter setting

- **Speed shortcut**— functional description: Directly select speed when running and directly set a speed value on custom-defined program screen
Operation instruction:
 1. May directly set corresponding speed when electronic meter is on

- **Incline shortcut**— functional description: Directly select incline when running and directly set a speed value under custom program setting
Operation instruction:
 1. May directly set corresponding incline when electronic meter is on

- **PREV/NEXT**— functional description: Select songs in USB
Operation instruction:
 1. May switch songs in connection with USB (when MP3 jack is in vacancy) after power on and connect safety key

- Volume +/- — functional description: Adjust volume of songs in USB
Operation instruction:
1. May adjust the volume of songs in connection with USB (when MP3 jack is in vacancy) after power on and connect safety key

V. Specification on Running Modes

A. Manual Mode Functions

Switch to manual mode:

Enter full-manual operation mode after electronic meter and the screen are on. Press START to run under manual operation mode.

Operation instruction:

Initial speed is 1KM/H. Positive counting of time, distance, and calorie is started from 0.

Adjust running speed through SPEED +/- and incline through INCLINE +/-.

If the running time exceeds 99 h and 59 min, system will not stop and the time will recount from 0.

B. Countdown Mode Functions

1. Switch to time countdown mode:

Select time countdown mode through MODE under full-manual operation mode. Then, the TIME window displays 30:00 mins which flashes., displaying that the running time may be adjusted through SPEED +/- or INCLINE +/-, set range being 8:00-99:00 mins and press START to run under time countdown mode.

Operation instruction: Initial speed is 1KM/H. T

IME window counts down as per the set running time. Positive counting of distance and calorie windows is started from 0. Adjust the running speed through SPEED +/- and incline through INCLINE +/- . When the set time counts down to 0, the electronic meter gradually stops. Once the speed reduces to 0, lattice window immediately displays “End” in company with 5 prompt tones (each per second). Five seconds later, all data are reset and the electronic meter automatically goes back to initial standby state.

2. Switch to distance countdown mode:

Select distance countdown mode through MODE under full-manual operation mode. Then, the DISTANCE window displays 1.0 km which flashes. Required running distance may be adjusted through SPEED +/- or INCLINE +/-, set range being 1.0~99.0 km and press START to run under distance countdown mode.

Operation instruction: Initial speed is 1KM/H. DISTANCE window counts down as per the set distance. Positive counting of time and calorie is started from 0. Adjust the running speed through SPEED +/- and incline through INCLINE +/- . When distance counts down to 0, the electronic meter gradually stops. Once the speed reduces to 0, speed window immediately displays “End” in company with 5 prompt tones (each per second). Five seconds later, all data are reset and the electronic meter automatically goes back to initial standby state.

3. Switch to calorie countdown mode: Select calorie countdown mode through MODE under full-manual operation mode. Then, the CALORIE window displays 50 flashes. Running calorie may be adjusted through SPEED +/- or INCLINE +/-, setting range being 20~990. Press START to run under calorie countdown mode.

Operation instruction: Initial speed is 1KM/H. CALORIE window counts down as per the set calorie. Positive counting of time and distance is started from 0.

Adjust speed through SPEED +/- and incline through INCLINE +/- . When the set calorie counts down to 0, the electronic meter gradually stops. Once the speed reduces to 0, speed window immediately displays “End” in company with 5 prompt tones (each per second). Five seconds later, all data are reset and the electronic meter automatically goes back to initial standby state.

C. Automatic Program Functions

Switch to automatic program:

Select automatic program through PROG under full-manual operation mode or mode setting status. Then, the TIME window displays 30:00 mins which flashes. (The required running time may be adjusted through SPEED +/- or INCLINE +/-, and sett range being 8:00-99:00 mins). Press START to run under automatic program.

Operation instruction:

Automatic program has 16 sections in total. The speed value and incline value of each section run as per the program’s defaults, run time of each section being 1/16 of the set time. TIME window counts down as per the set running time. Positive counting of distance and calorie windows is started from 0. Adjust speed through SPEED +/- and incline through INCLINE +/- . When the program runs to the next section, there will be 3 prompt tones before such running. When the program runs to the next section, the speed and incline will be automatically adjusted to the corresponding defaults. When the set time counts down to 0, the electronic meter gradually stops. Once the speed reduces to 0, speed window immediately displays “End” in company with 5 prompt tones (each per second). Five seconds later, all data is reset and the electronic meter automatically goes back to initial standby state.

VI. Fat Rate Test Functions

VII. Hand-Grasping Heart Rate Function Description

Test method:

Hold armrests naturally with palms on sheet steels of left and right armrests. The LED HEART RATE window will display the initial heartbeat after about 5s. Keep holding on armrests and the data displayed on HEART RATE window will gradually change. 30s later, the value approaches your current heartbeat.

Instruction:

irregular heart rate data may be displayed when:

1. Hold too tightly during hand-grasping test. Please hold with moderate intensity.
2. Hold the armrests firm when testing hand-grasping heart rate during running, by which continuous variation of contact will be displayed. It is recommended to stop running, stand on edges of the treadmill and hold the armrests still when hand-grasping heart rate testing is required.
3. Hands are dry or cold, or when skin of palms is relatively thick.

Note: Since the detected data of hand-grasping heart rate test may be affected by the test method and various influential factors, it may only be taken as sports reference only instead of medical data.

VIII. Sleeping Function

IX. Specification on Safety Key Function

X. Specification on Quick Stop

After safety key is connected, the quick stop switch must be closed for the normal start of the treadmill. When the treadmill is running, once pressing STOP, it will quickly stop. The lattice window of the electronic meter displays “QUICK STOP OPEN”. At this moment, the treadmill is in an emergency stop. Press QUICK STOP again to remove emergency stop. Each time QUICK STOP is pressed, the status circulates like: Emergency stop— Remove emergency stop— Emergency stop— Remove emergency stop

XI. MP3 Function

XII. USB Function

XIII. Display Range of Values

	Initial	Set initial value	Setting range	Display range
Time (min:s)	0:00	30:00	8:00-99:00	0:00~99:59
Speed (km/h)	0.0	N/A	N/A	1—25
Distance (km)	0.00	1.00	1.0—99.0	0.0—99.9
Heart rate (times/min)	P	N/A	N/A	40—199
Calorie (kcal)	0.0	50.0	20—990	0—999
Incline (section)	0	N/A	N/A	0-10% (18 Levels)

Instruction on Common Errors of Treadmill

1: Electronic meter display: E01! Communication failure

Troubleshooting: check upper and lower control connection lines to see if they are well connected; if so, replace the electronic meter or frequency converter

2: Electronic meter display: E05! Overcurrent protection

Troubleshooting: Overcurrent when the motor is running and exceeds the set value; replace motor

3: Electronic meter display: E08! Overvoltage protection

4: Electronic meter display: E09! Overload protection

5: Electronic meter display: E0A! Phase loss

Troubleshooting: check if three-phase connection wire is well connected to the frequency converter

6: Electronic meter display: E0B! Raise and fall failure

Troubleshooting: check to see if the connection wire of incline motor is properly connected to the frequency converter; replace motor

7: Electronic meter display: E0C! Overheat protection

8: Electronic meter display: Safety key disconnected

Troubleshooting: check if magnetic safety key is properly placed; if so, replace electronic meter

10. DESCRIPTION OF PROGRAM

Press program key and select any of P01---P12, which is built-in program, when “TIME” window displays default value and flickers, and lattice window displays graph of current program.

Adjust the time of exercise needed through speed or ascension +/- . Press Start, the treadmill will be started according to the speed and incline of the first section after countdown of 3s. The built-in program is divided into 16 sections. The running time of each section is 1/16 of set time. The treadmill automatically enters the next section after the last section is over with speed and incline automatically adjusted to be value of the section. The program is over and incline is 0 after running of all sections is over, and the treadmill slowly stops.

Speed and incline can be adjusted in running. But it will be automatically adjusted to be default speed and incline of the section of program when entering the next section. You can also directly press STOP or disconnect safety lock in exercise to stop the treadmill.

⌘ *Lattice window displays graph of current program and the current section of program of lattice window will flicker when started.*

See Table 1 for built-in program data

1. Self-compiled program of users

Keep pressing the program key and select any of U1—U3, which is self-compiled program. Press mode key to enter edit state. Corresponding section of program starts flickering, speed window displays speed of the section and ascension window displays ascension. Press speed +/- to adjust speed of the section and press ascension +/- to adjust slope. Press mode key to enter the setting of next section until setting of all sections is over. The data of program section set will be kept permanently, so it is unnecessary to adjust unless modification is made. Setting of exercise time and other operations of self-compiled program are completely same as built-in program.

2. Mode of fat measurement:

Keep pressing program key in standby state to enter mode of fat measurement.

Press mode key to select category of parameters (“sex”, “age”, “stature”, “weight”), and press “speed +/- ” or “ ascension +/-” to adjust parameters when selecting a category of parameter. Press mode key again after all parameters are adjusted. Hold the handle, and corresponding window displays your body fat index.

Range of display and setting of input parameters

Category of parameter	Default value	Setting range	Remarks
Sex	(0)	0/1	0 is male 1 is female
Age	25	10—99	
Stature	170 CM	100—240 CM	
Weight	70KG	20—160KG	

3.Heartbeat measurement:

Hold steel sheet of left and right armrests, the heartbeat window will display your heartbeat after about 5-10s.

Heartbeat data is only for rough reference of exercise degree and cannot be used as medical data.

4. Functions of media and sound:

This machine accepts input of multiple media, such as U-disk and external audio. Ensure that amplifier is not mute when playing music or other sound signals.

4.1 Play of U disk

Insert U disk with music file, the system will automatically play. Press up and down to select songs and volume +/- to adjust volume.

4.2 External audio input:

Insert sound source of external audio equipment (e.g.MP3) into audio input port through audio cable attached to the machine to play music. Press volume +/- to adjust volume.

⌘ *Priority of audio output is as follows when all media signals exist:*

1. External audio input;
2. U disk.

5. Function of dormancy:

The system closes all displays and enters state of dormancy after it is stopped for 10min. Press any key to wake it up.

6.Function of safety lock

Open safety lock in any state for emergency stop of treadmill. The screen displays “OFF” in case of emergency stop of treadmill, when the treadmill can only be turned off. The treadmill enters standby state again and waits for input order after the safety lock is correctly installed again.

7. Range of display and setting of parameter

	Display range	Default value of mode	Default value of program	Setting range
Speed	1-20.8KM/H	-----	-----	-----
Ascension	0-10% (18 Levels)	-----	-----	-----
Time	0:00—99:59	30:00	30:00	5:00---99:00
Mileage	0.00KM—99.9KM	1.0KM	-----	0.5KM—99.5KM
Calorie	0Kcl—999Kcl	50Kcl	-----	10Kcl—995Kcl

Table 1:

Built-in program data sheet

Note: the value is original kilometers divided by 1.6 after speed display is changed into mile

Time period Program		Set time/16 time periods = running of each time period (unit of speed is KM/H)															
		1	2	3	4	5	6	7	8	9	10	11	12	13	14	15	16
P1	INCLINE	0	0	2	2	2	2	2	2	2	2	4	4	4	2	2	0
	SPEED	4	6	6	6	10	10	6	6	6	4	4	2	6	6	4	4
P2	INCLINE	0	2	2	2	6	6	2	2	4	4	2	2	4	2	2	0
	SPEED	2	2	8	2	2	8	8	12	4	4	12	4	4	12	4	2
P3	INCLINE	0	2	2	4	4	6	4	6	4	2	2	2	4	2	2	0
	SPEED	2	4	8	8	4	4	8	8	10	10	12	4	4	8	4	4
P4	INCLINE	0	2	2	4	4	6	8	8	6	6	6	4	4	2	2	0
	SPEED	4	6	6	6	12	12	12	12	6	6	4	4	4	6	6	2
P5	INCLINE	0	2	4	6	4	2	2	0	0	2	2	2	2	2	4	0
	SPEED	2	4	6	12	12	12	4	4	4	4	12	12	12	6	4	2
P6	INCLINE	0	2	4	4	4	4	4	2	2	2	2	2	2	2	2	0
	SPEED	4	4	6	6	6	6	8	8	6	6	8	8	6	8	6	4
P7	INCLINE	0	2	2	2	2	4	4	4	4	4	4	2	2	2	2	0
	SPEED	4	8	8	8	8	4	4	12	12	4	4	8	8	4	4	2
P8	INCLINE	0	2	2	4	2	2	2	4	2	2	2	4	2	2	2	0
	SPEED	2	2	6	6	6	8	8	10	10	12	8	6	6	6	4	4
P9	INCLINE	0	2	2	4	4	6	6	8	8	10	8	6	4	2	2	0
	SPEED	2	4	8	10	2	4	8	10	2	4	10	2	4	10	4	2
P10	INCLINE	0	2	2	2	4	4	4	4	4	4	6	6	6	4	4	0
	SPEED	4	6	6	8	8	8	10	10	10	8	8	6	8	6	4	4
P11	INCLINE	0	2	2	2	4	4	4	4	4	4	6	6	6	4	4	0
	SPEED	4	6	6	8	8	8	6	8	6	8	6	10	6	10	8	4
P12	INCLINE	0	2	2	4	4	6	6	8	8	6	6	4	4	2	2	0
	SPEED	4	6	8	10	8	6	4	6	8	12	8	6	8	12	12	6

11. FAULT ANALYSIS AND HANDLING

11 . Fault Analysis and Handling

Fault code	Cause	Solution
E01	Poor communication between electronic meter and controller	<ol style="list-style-type: none">1. Inspect whether connecting line between electronic meter and controller suffers from poor contact.2. Poor contact of main IC of controller. Reinsert it.3. Power of controller is abnormal. Replace controller.
E02	Protection against blast shock	<ol style="list-style-type: none">1. Open circuit or poor contact of motor. Replace motor or check connector.2. Breakdown of power tube. Replace power tube or controller.
E04	Failure of ascension learning	Replace ascension motor
E05	Overcurrent protection	<ol style="list-style-type: none">1. Overload.2. Resistance of running platform is too high, and it shall be oiled.3. Motor is damaged. Replace it.
E06	Error in power-on self-test of controller	Replace controller
E07	Loss of parameter	Replace controller or input parameter again

12. DAILY MAINTENANCE

Maintenance of electric treadmill:

Appropriate maintenance is the only way to keep your treadmill in optimum state. Wrong maintenance will damage or shorten the service life of treadmill.

Important reminder:

- Please don't clean the treadmill with sandpaper or solvent. The controller of treadmill shall not be directly exposed to sunlight or damp to prevent damage.
- Frequently inspect and lock all parts of treadmill and immediately replace the damaged parts.

Regulate running belt

Adjustment of running belt is equipped with two functions: adjustment of degree of tightness and central position of running belt. The running belt has been adjusted when leaving the factory, but it will be stretched after use to deviate from central position to cause damage by wearing trim strip and rear protecting cover. It is normal to stretch the running belt in use.

Adjust running belt

If the running belt is slip or not smooth when you use the treadmill, you can improve it by adjusting degree of tightness of running belt.

How to adjust running belt

1. Insert 5mm hexagon wrench into the regulating screw on the left of running belt, and turn the wrench by 1/4 of a circle clockwise to regulate the rear roller to tighten the running belt.
2. Repeat step 1 to adjust the screw on the right. Ensure that the regulating screw is turned by the same distance to make the rear roller parallel with the frame.
3. Repeat step 1 and 2 until the running belt is not slip.
4. Note: the running belt shall not be too tight, which will damage the running belt, roller bearing, etc., increase pressure of front/rear roller, and bring abnormal sound or other problems. To reduce tension of running belt, please turn the wrench anticlockwise by same distance on both sides.

Adjust running belt to the middle

When you use the treadmill, the force of feet is different, and pressure on running belt is unbalanced, which makes the running belt deviate from the center. Such deviation is normal. It will return to the center when nobody is running on the running belt. You need to adjust it to the center if it fails to return to the center.

1. Keep the treadmill in no-load running and adjust speed to 6KM/H.
 2. Observe the distance from running belt to left and right edgestrips
- If the running belt tilts towards the left, turn the left screw by 1/4 of a circle clockwise with Allen wrench.
 - If the running belt tilts towards the right, turn the right screw by 1/4 of a circle clockwise with Allen wrench.
 - If the running belt is still not in the middle, repeat the above steps until it is in the middle.

3. Adjust speed to 16KM/H after adjusting running belt to the middle, and observe deviation of running belt and smoothness of running. Repeat steps of adjustment in case of deviation.
4. Warning! Please don't tighten the roller excessively! This will cause permanent damage to the bearing!

You need to tighten the running belt again if the above steps fail to reach the effect.

Lubricating oil

The treadmill is oiled when leaving the factory, but lubricity of treadmill shall be inspected frequently, which helps to keep it in optimum state. The treadmill must be oiled after 1 year or running for 100h.

Lift one side of the running belt and touch the surface of running platform after running for 30h or 30 days. It is unnecessary to lubricate if there is silicone oil; if the surface is clearly dry, please oil it as instructed below.

Please use non-petroleum silicone oil

How to oil the treadmill:

1. As shown in the figure, it needs to oil the running belt after the treadmill is used for some time. Lift one side of the running belt, place the silicone oil bottle below the running belt and apply silicone oil to running board.
(Apply silicone oil to the middle of running board)
2. Turn on the treadmill to run for some time after oiling to uniformly apply silicone oil to running belt.

Note: stop the treadmill to make the running belt still when oiling the running belt. Lower surface in the middle of running belt.

Cleaning

Frequently clean the treadmill to guarantee its service life.

- **Warning:** cut off the power when cleaning the treadmill. The power line must be pulled out from the socket.
- **After use:** clear sweat stains and sundries on instrument and other parts with clean towel and damp cloth.
- **Note:** don't use corrosive articles and liquid to prevent damage to electronic elements. Don't expose electronic elements to sunlight.
- **Every week:** clean the ground every week, and clear dirt brought by shoes and other sundries on the ground.

Storage: please place your treadmill in clean and dry environment, and ensure that power switch is off and plug is not in power socket.

Movement and folding: handling wheel is added in design to move the treadmill. Please confirm that power is off and the body of treadmill is folded before moving.

13. IMPORTANT MATTER

- **Warning**

Please consult your doctor and receive complete physical examination before using the product. Don't carry out frequent and violent exercise without permission of doctor. Please stop using the product and consult your doctor if you feel unwell in use. The product shall be used correctly. Please read service manual in detail before exercise.

Please keep children and pets away if the product is unattended or idle.

Please wear suitable clothes including sneakers. Please don't loosen your clothes in exercise to prevent them from being hooked by the machine.

Ensure that all bolts and nuts are tightened when using the equipment. Regularly maintain the treadmill to keep it in good condition.

Before use:

How to start exercise plan depends on your physical condition. If you have not exercised for years or you are seriously overweight, you must gradually increase exercise time, such as a few minutes every week.

At the beginning you may only exercise for a few minutes in target heart rate scope. Anyway, your aerobic fitness will be improved in about 6-8 weeks. Don't lose heart if it takes more time. It is very important to exercise at your own pace. Some day you will be able to exercise continuously for 30min.

- Please consult your doctor before exercise or training. Ask the doctor to inspect your training and diet plan and give suggestions on your exercise plan.
- Set exercise goal after consulting with your doctor to ensure that the plan is practical, and start exercise plan at leisure.
- You can add some aerobic exercises into exercise plan, such as walking, jogging, swimming, dancing or riding. Test pulse frequently. If you have no electronic heartbeat monitor, consult the doctor about how to correctly measure pulse with hand from wrist or neck. In addition, you must set target heart rate on the basis of age and physical condition.

Drink enough water in exercise. You must supplement water lost due to overexercise to prevent dehydration. Don't drink a great deal of ice water or beverage. The temperature of drinking water or beverage shall be room temperature.

- **Target heart rate**

Measure pulse:

To determine whether your heartbeat is in target heart rate scope, first you must know how to measure heart rate.

The simplest way is to measure pulse of carotid arteries between trachea and neck muscles on both sides of neck.

Count number of beats of pulse in 10s, and multiply the number of beats by 6 to obtain heartbeat per minute.

