

FRENCH FITNESS

FF-FSR90

FRENCH FITNESS FSR90 MULTI FUNCTIONAL
TRAINER SMITH & RACK SYSTEM (V2)

ASSEMBLY AND EXERCISE MANUAL

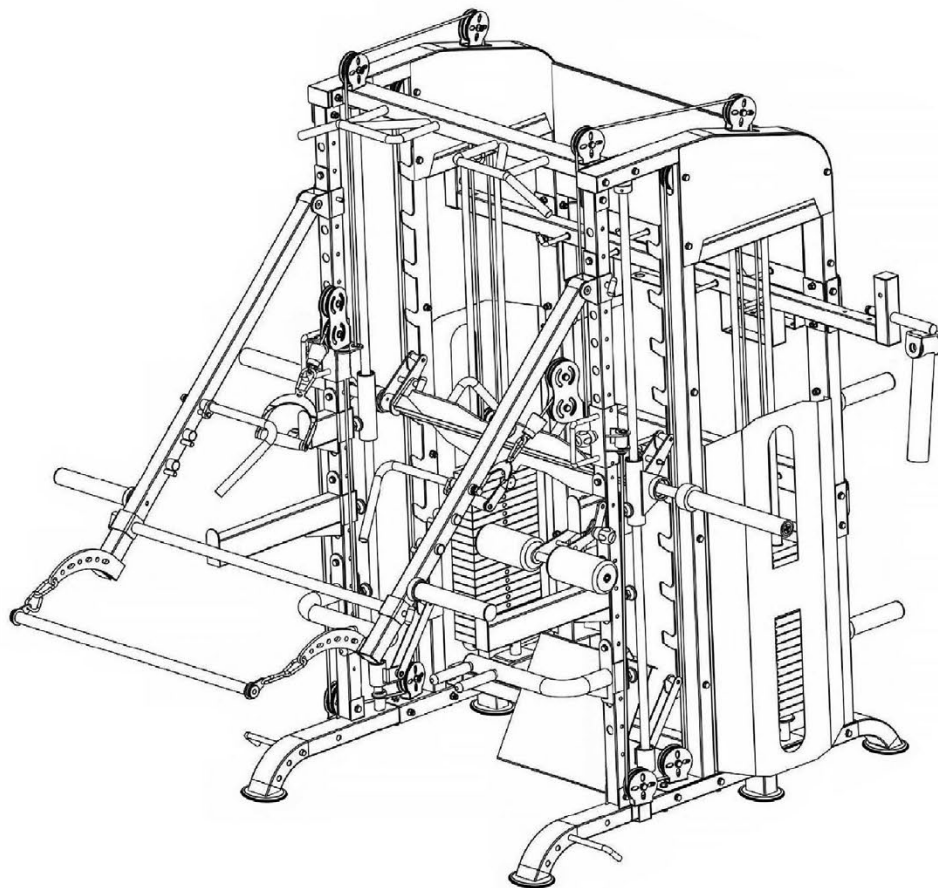

FEATURES

- Thick steel barbell hooks with quick and easy height adjustment
- Chrome/stainless steel used for most contact points (more scratches-resistant)
- Adjustable/Removable Dip Handles
- Thick steel barbell safety hooks with quick and easy height adjustment
- Heavy duty cables and pulley
- Extreme core trainer accessory
- Multi-grip chin up bar with comfortable knurling
- Quick and easy pop pin functional adjustment
- Thick steel support plates
- Weight plate storage
- Storage holder Olympic barbell

SMITH MACHINE

- Straight up and down movement
- Ultra smooth smith machine movement and solid steel tubing

- Smith Bearing Type: Linear
- Adjustable safety catches for Smith Machine exercises

THE ULTIMATE ALL-IN-ONE MACHINE:

- Smith Machine
- Squat Rack
- Functional Trainer
- Landmine
- Dip Bars
- Pull Up Bar
- Lat Pulldown
- Jammer Arm
- Leg Press
- Bench (Optional)
- Preacher Curl (Optional on Bench Attachment)
- Leg Extension / Leg Curl (Optional on Bench Attachment)

TECH SPECS

- Jammer Arms (Thickness): 2" x 2"
- Frame (Thickness) : 2" x 2.75"
- Cable Columns (Thickness): 2" x 2"
- Max Load (J Hooks): 550 lbs
- Max Load (Bar Catches): 660 lbs
- Max Load (Smith Bar): 600 lbs
- Max Load (Plate Storage): 600 lbs
- Max Load (Pull Up Bar): 1100 lbs
- Weight: 992 lbs (450 kgs)
- (2) 220 lb weight stacks
- 2:1 Ratio
- Weight Stack Increments: 11 lbs (20) 11 lb Plates per side (Feels like 5.5 lb increments due to 2:1 ratio)
- Cables extends 62"
- Width (Inner Part of Cage): 48"
- Width (Outer Part of Cage): 52"
- NOTE: Most Olympic bars will not fit. The FSR90 / FSR80 Chrome Olympic Bar (Optional) will fit.
- Dimensions: 87 3/8"h x 88 1/8"W x 65"D (65" Depth is w/Bar Catches connected)
- Dimensions w/Jammer Arms Fully Extended" 101.5" (Jammer Arms extend 56.5" from Cable Columns)
- Bushing Type: Weights have Plastic / Nylon Bushings.

ACCESSORY FEATURES

- J Hooks (Extends 4.5" From Cable Columns)
- Bar Catches (Extends 16" From Cable Columns - Included in the Depth measurement of 65)
- 86" Olympic Smith Bar
- Lat Pull Knee Cushion (latches on to support you at the knees for lat pull downs)
- Jammer Arms (They are used for iso lateral seated, standing and floor based exercises including Chest, Shoulder, and Seated / Standing Rows.
- They can also be used in conjunction with the included straight bar for leg presses, squats, deadlifts, shoulder shrugs, and more. They allow more explosive movements with greater stability and control and than free weights. They connect to the cable columns on the front of the FSR machine)
- #18 Platform (Allows for Leverage Squats and Calf Raises. Also Shoulder & Push Presses with Jammer Arms)

WARRANTY

- **10 Years Parts, 1 Year Labor (Light Commercial)**

ACCESSORIES INCLUDED

- (1) Band Pegs (Set)
- (2) Rubber Grip Stirrup Handles (Set)
- (3) Pins (7)
- (4) Carabiners (5)
- (5) Extension Chains (Set)
- (6) Spring Collars (6)
- (7) Jaw Lock Collars (Set)
- (8) Safety Bar Catches (Set)
- (9) Adjustable Dual Dip Bars (Set)
- (10) Lat Pull Knee Cushion w/Right J Hook
- (11) Left J Hook
- (12) Landmine Attachment
- (13) Straight Bar
- (14) Lat Bar
- (15) Dual Hook Revolving Straight Bar
- (16) Dual Hook Jammer Arm Connector
- (17) Vertical Leg Press Plate
- (18) Platform
- (19) Jammer Arms (Set)



TABLE OF CONTENTS

OVERVIEW 4

RECOMMENDED STRETCHING EXERCISES 5

FITNESS SKILLS 6

CLEAN GUIDE RODS 8

PAINT PARTS 9

INSTALLING STEPS 13

EXERCISES 31

Overview

The French Fitness FSR90 Functional Trainer Smith & Squat Rack Machine is a strength training equipment newly developed by French Fitness, combining the international and domestic markets. It has a smooth structure, beautiful appearance, firm connection and small footprint. The various configured functions can achieve the effect of the whole body being exercised through comprehensive use of training. This product was put on the market at the same time in the international and domestic markets. It is one of the first-choice equipment for family fitness at home and abroad.

Safety Guidelines

Successful resistance training programs all share common characteristics: safe. When doing physical activities, there are some inherent risks in resistance training. Using the correct lifting method, correct breathing method, keeping the equipment in good working condition and wearing appropriate clothing can greatly reduce or completely avoid the possibility of injury.

- It is recommended that you consult a doctor before doing any exercise program. This is very important for people who are over 35 years old or had health problems before.
- Warm-up must be done before starting exercise. Try to warm up your whole body before you start. It is important to warm up for the muscle groups you will use during the exercise. It is very simple to do. Just repeat a small amount of warm-up activities.
- Use the right way. Focus on working out the muscle groups used in the exercise you are doing. If other muscles are also involved, you may need to re-evaluate the weight you want to lift. Using the right way also includes controlling the movement amplitude.
- Correct breathing method. When in the eccentric phase of the muscles, inhale: when in the lifting process or in the centripetal phase of the muscles, exhale. Do not hold your breath during exercise.
- Please wear appropriate clothing and shoes when exercising. Wearing loose and supportive sports shoes and comfortable and breathable sportswear will reduce the possibility of injury.
- Keeping the equipment in good working condition is extremely important for the safety of resistance training programs. The wear of roller skates and cables should be checked frequently, and new ones should be replaced if necessary. The equipment should be lubricated in accordance with the manufacturer's instructions.
- You should read and understand the content of all the warning labels on the equipment. Before use, the user must be familiar with the correct way of using the equipment.
- Please keep your hands, feet, loose clothing and long hair away from all moving parts.
- Do not try to lift a weight beyond your ability.
- Check the equipment daily for loose or worn parts. If you find a problem, do not use the equipment. Do not proceed until loose parts are tightened, or worn or defective parts are repaired or replaced.

Recommended Stretching Exercises

The pictures below show the correct postures for several types of basic stretching exercises. Move slowly when doing stretching exercises - don't move suddenly.

1. When standing during the toe-touching stretching exercise, bend your knees slightly and let the part above your hips lean forward slowly. When touching your toes down, stretch as much as possible to relax your back and shoulders. Maintain the posture and relax after counting to 15. Repeat the above movements three times. Stretched parts: your ligaments/inner knees and your back.
2. The ligament stretching exercise takes a sitting position with one leg extended forward. Place the sole of the other foot toward your body and place it on the inner thigh of the extended leg. Touch your toes as far forward as possible. Maintain the posture and relax after counting to 15. Repeat the movements three times for each leg. Stretched parts: your ligaments, low back and inguinal canals.
3. During the calf/heel stretching exercise, stand on both of your legs with one behind the other, lean forward and put your hands against the wall. Straighten the leg at the back and keep the foot flat on the floor. Bend the leg at the front, lean forward, and move your hips toward the wall. Maintain the posture and relax after counting to 15. Repeat the movements three times for each leg. To further stretch the calcaneal tendon, you can bend the leg at the back at the same time. Stretched parts: your calves, calcaneal tendons and ankles.
4. During the quadriceps stretching exercise, put one hand against the wall to maintain balance and grasp one foot backward with the other hand. Keep the heel as close as possible to your hips. Maintain the posture and relax after counting to 15. Repeat the movements three times for each leg. Stretched parts: quadriceps and hip muscles.
5. The inner thigh stretching exercise takes a sitting position with the soles of your feet facing each other and your knees turned inside out. Pull your feet as close to the inguinal canals area as possible. Maintain the posture and relax after counting to 15. Repeat the movements three times. Stretched parts: quadriceps and hip muscles.



Fitness Skills

Before you start the exercise

It is strongly recommended that you consult your doctor before starting any nutrition or exercise program. In order to avoid injury during exercise, please warm up and relax before exercise and after exercise. Each exercise time must be at least 60 seconds.

While exercising

Give yourself plenty of rest time between a series of fitness and exercise. Please breathe correctly throughout your exercise (take deep breaths, inhale through your nose and exhale through your mouth). To avoid injury to the spine, please maintain the correct postures. Please concentrate on exercising your muscles throughout your fitness process.

After exercise

Please take a day off after exercise to reduce muscle soreness and speed up recovery time. It is recommended that you continue to do some relaxing exercise after the strenuous exercise.

Don't forget to exercise your heart rate

For your overall health, any functional strength training program should include heart rate exercise, such as walking, running or riding an exercise bike, to help you accelerate your metabolism and strengthen your cardiorespiratory function.

Area occupied:
 61" Depth x 86.61"W x 86.61"H
 Net weight: 1146 lbs

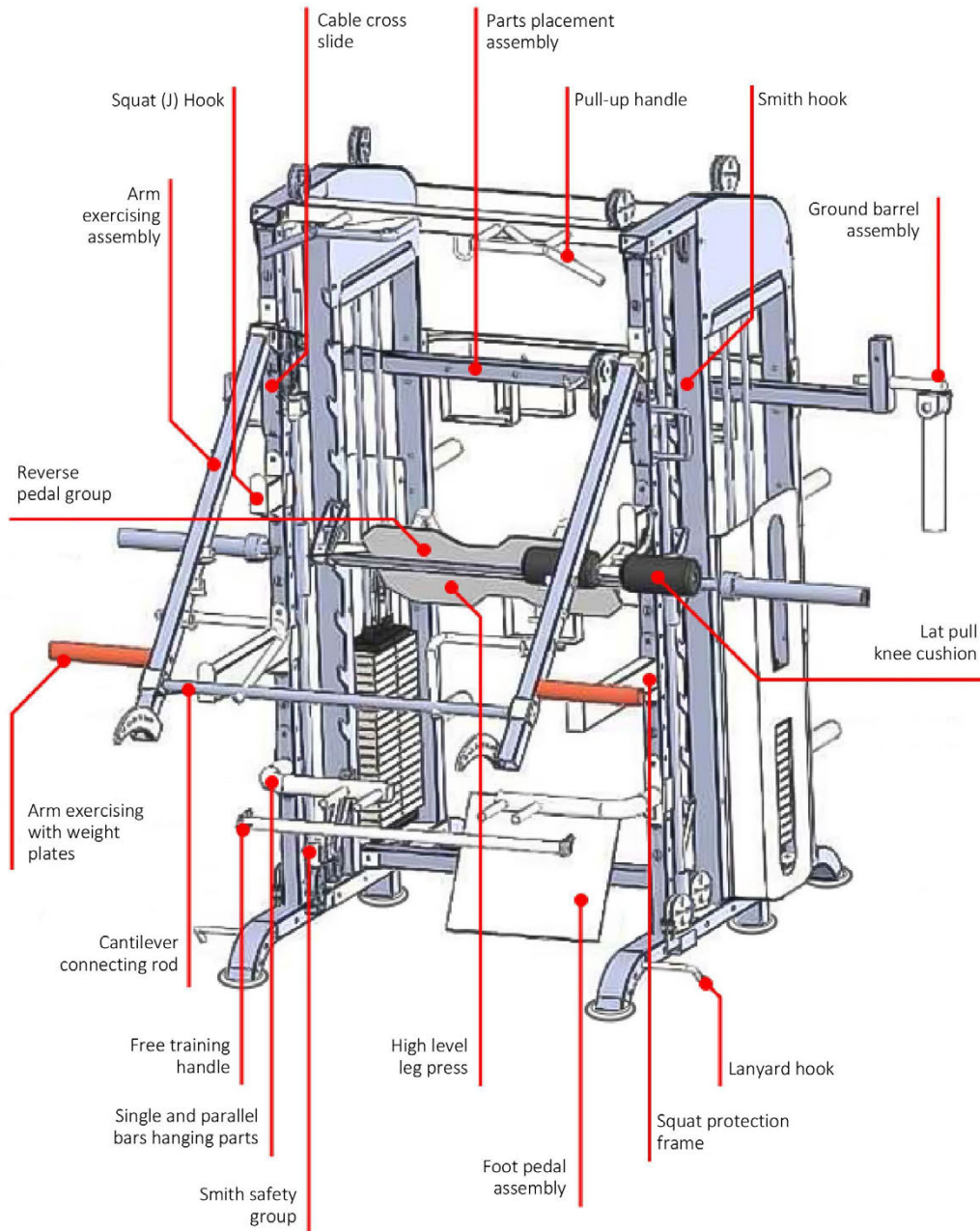

CLEAN GUIDE RODS

Step must be completed prior to installing. Failure to do so can leave residue from packaging and other sources stuck in the bushings

Guide rods need to make sure they are cleaned prior to installation otherwise this will cause the top plate to get stuck. It causes buildup in the bushings of the top plates. They just need to be cleaned out as well as the guide rods.

Use Silicon Spray and fiber to remove any excess residue. These can be found around the house or at a nearby hardware store, pics below. Use silicon Spray and fiber.

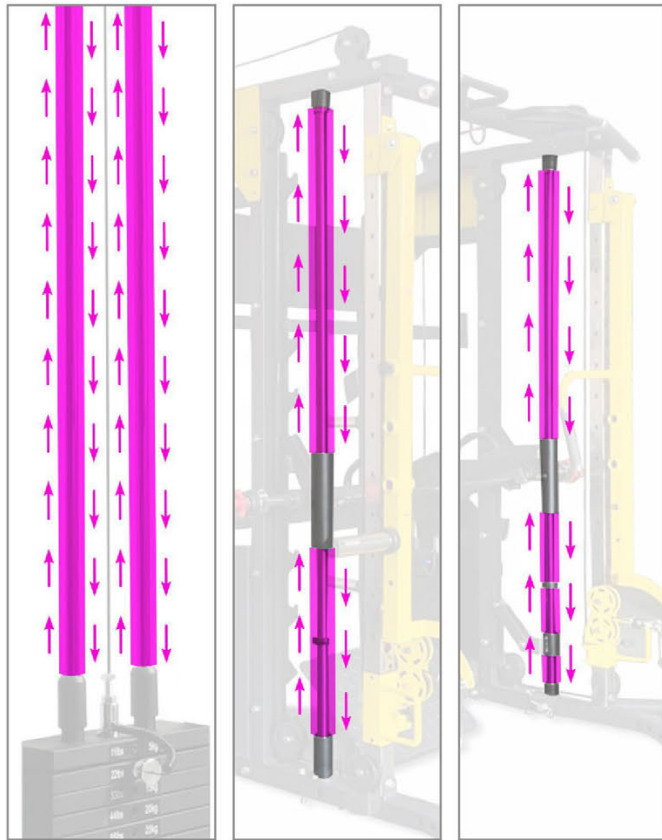
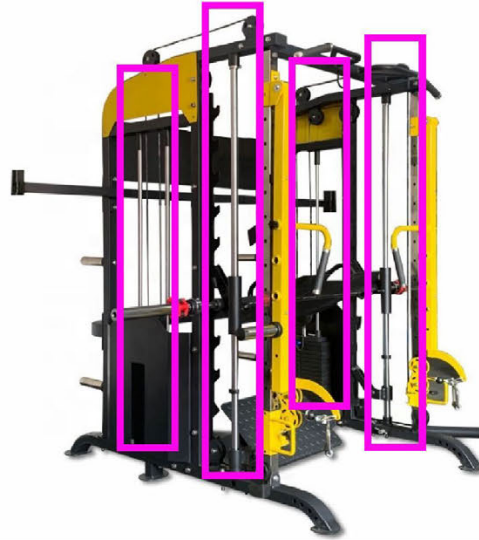

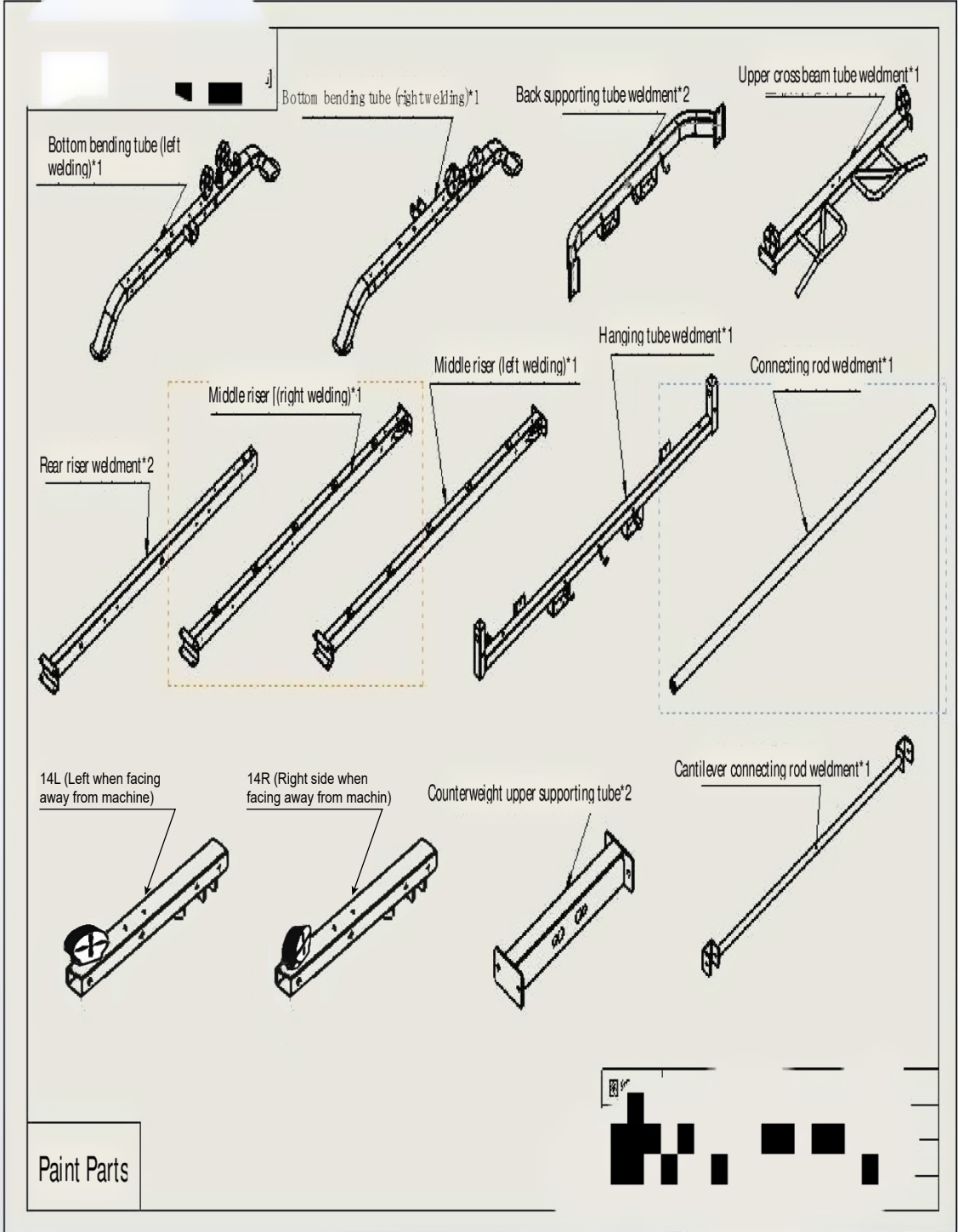

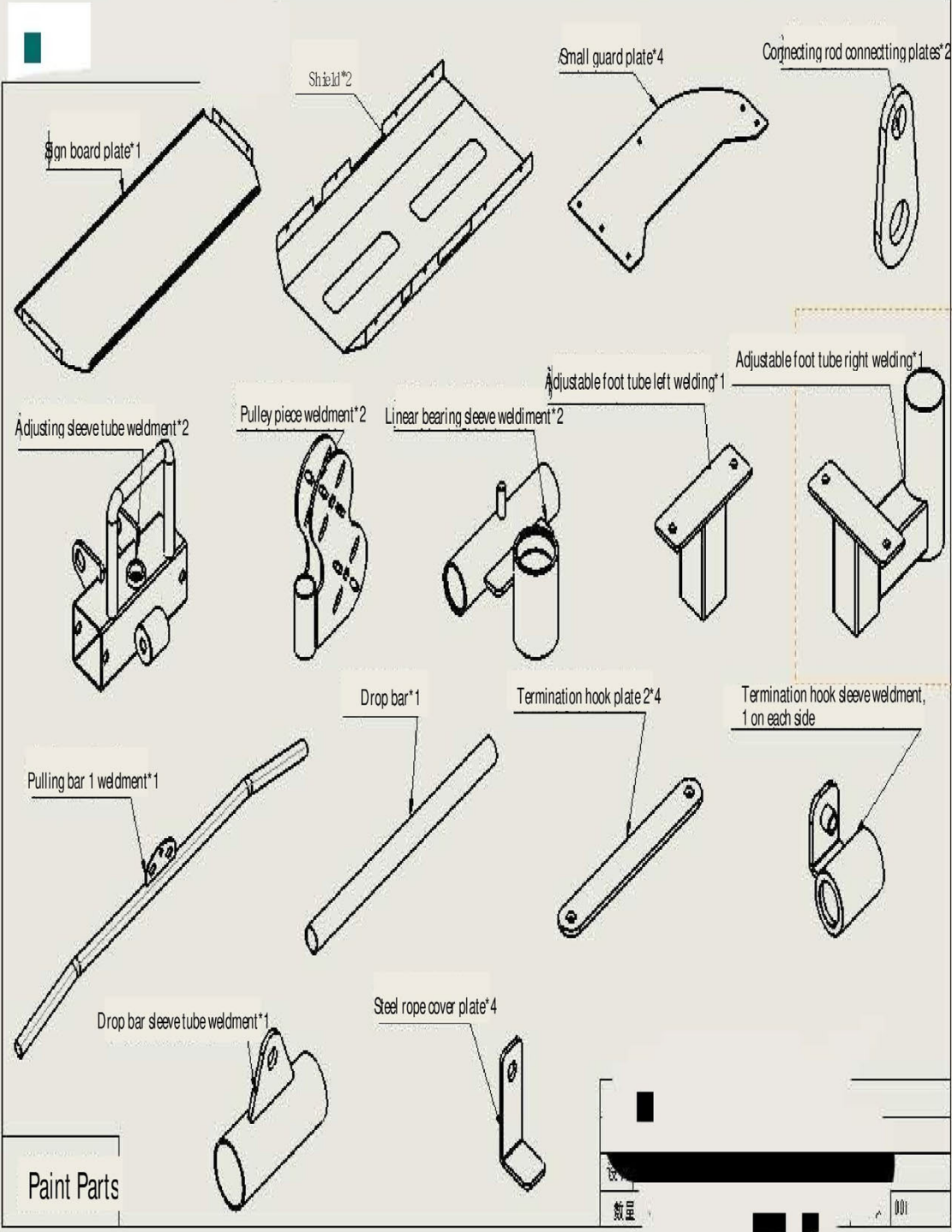

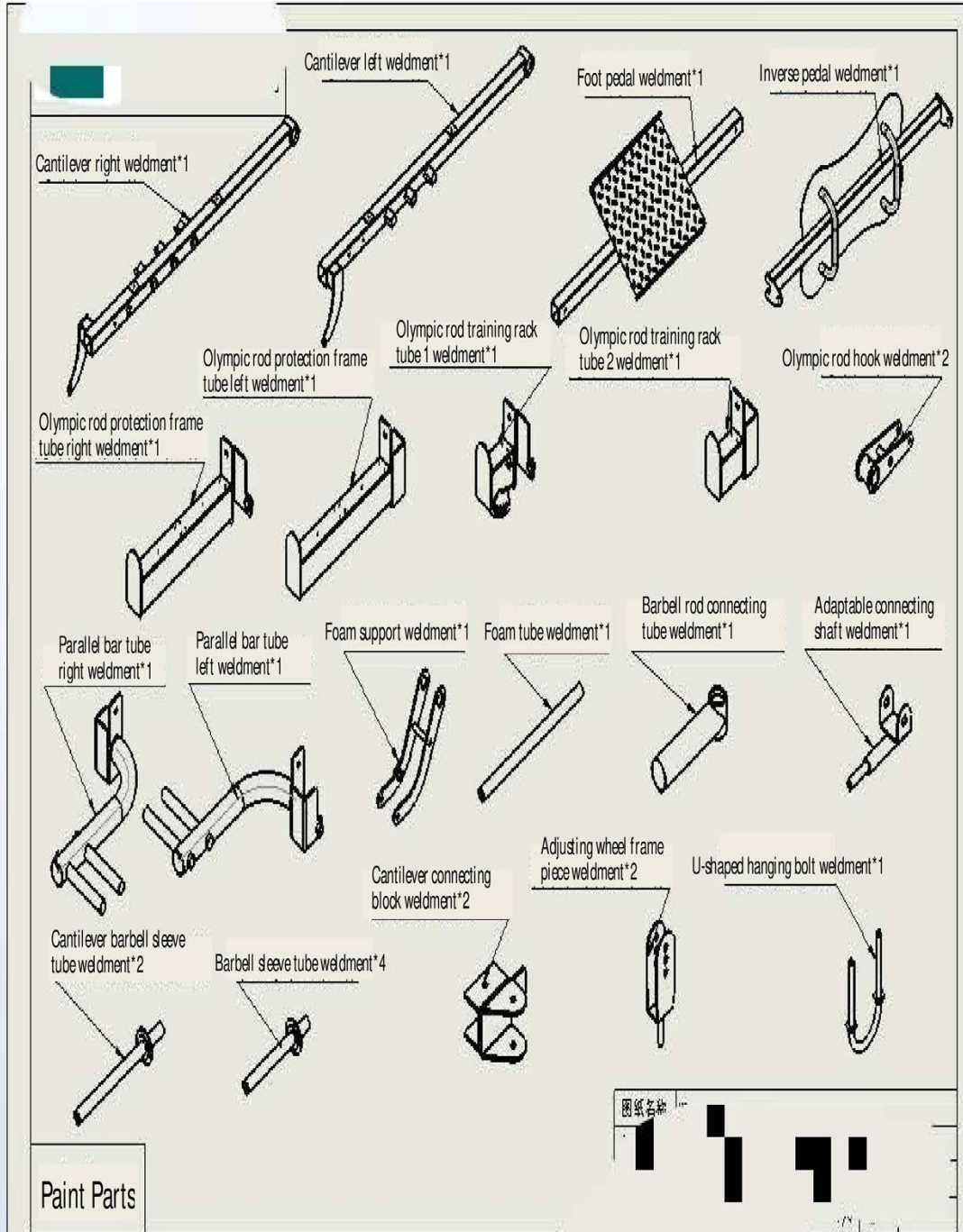

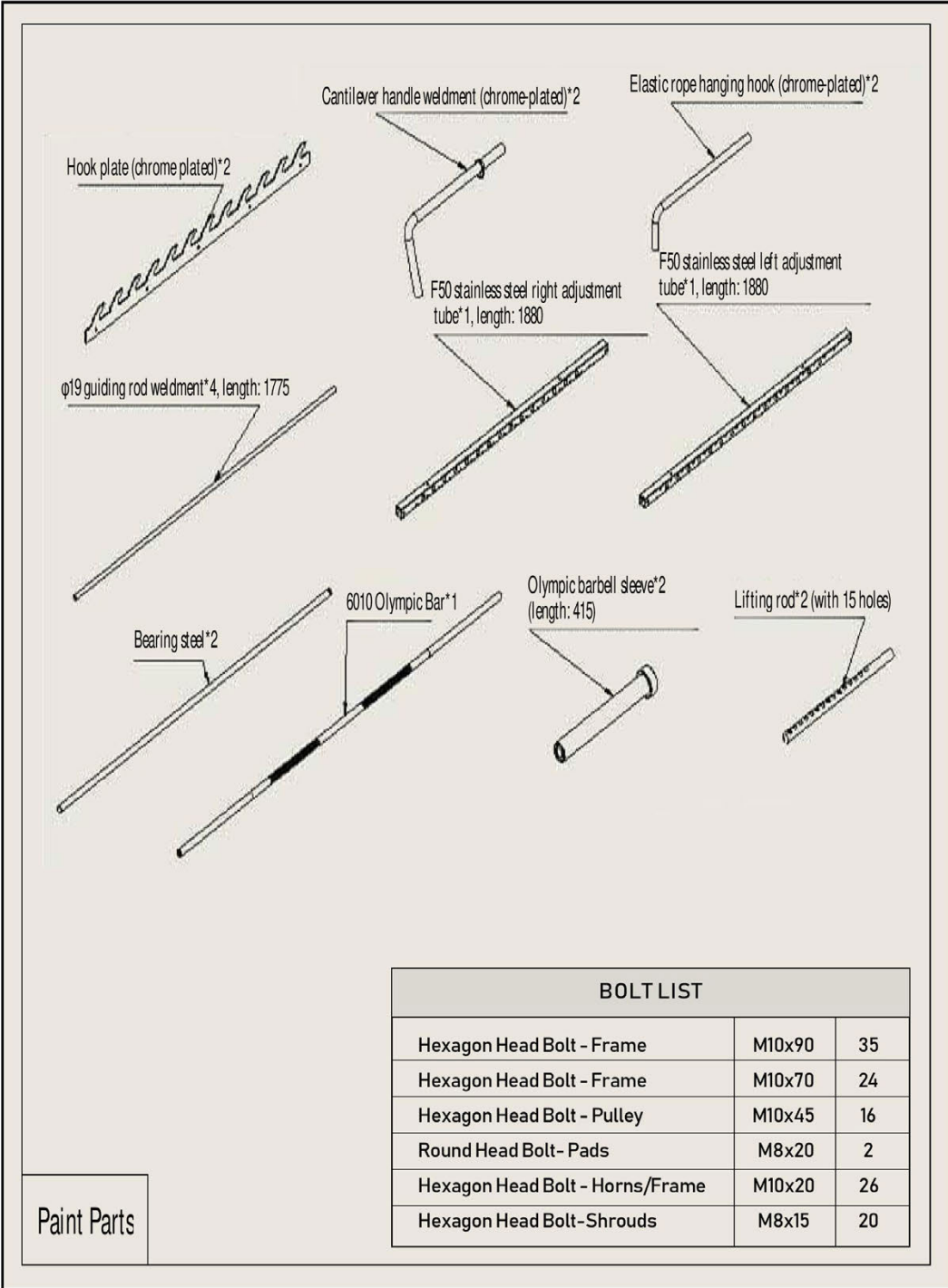

Paint Parts

BOLT LIST		
Hexagon Head Bolt - Frame	M10x90	35
Hexagon Head Bolt - Frame	M10x70	24
Hexagon Head Bolt - Pulley	M10x45	16
Round Head Bolt - Pads	M8x20	2
Hexagon Head Bolt - Horns/Frame	M10x20	26
Hexagon Head Bolt - Shrouds	M8x15	20

Installing Step 1 Exploded Diagram

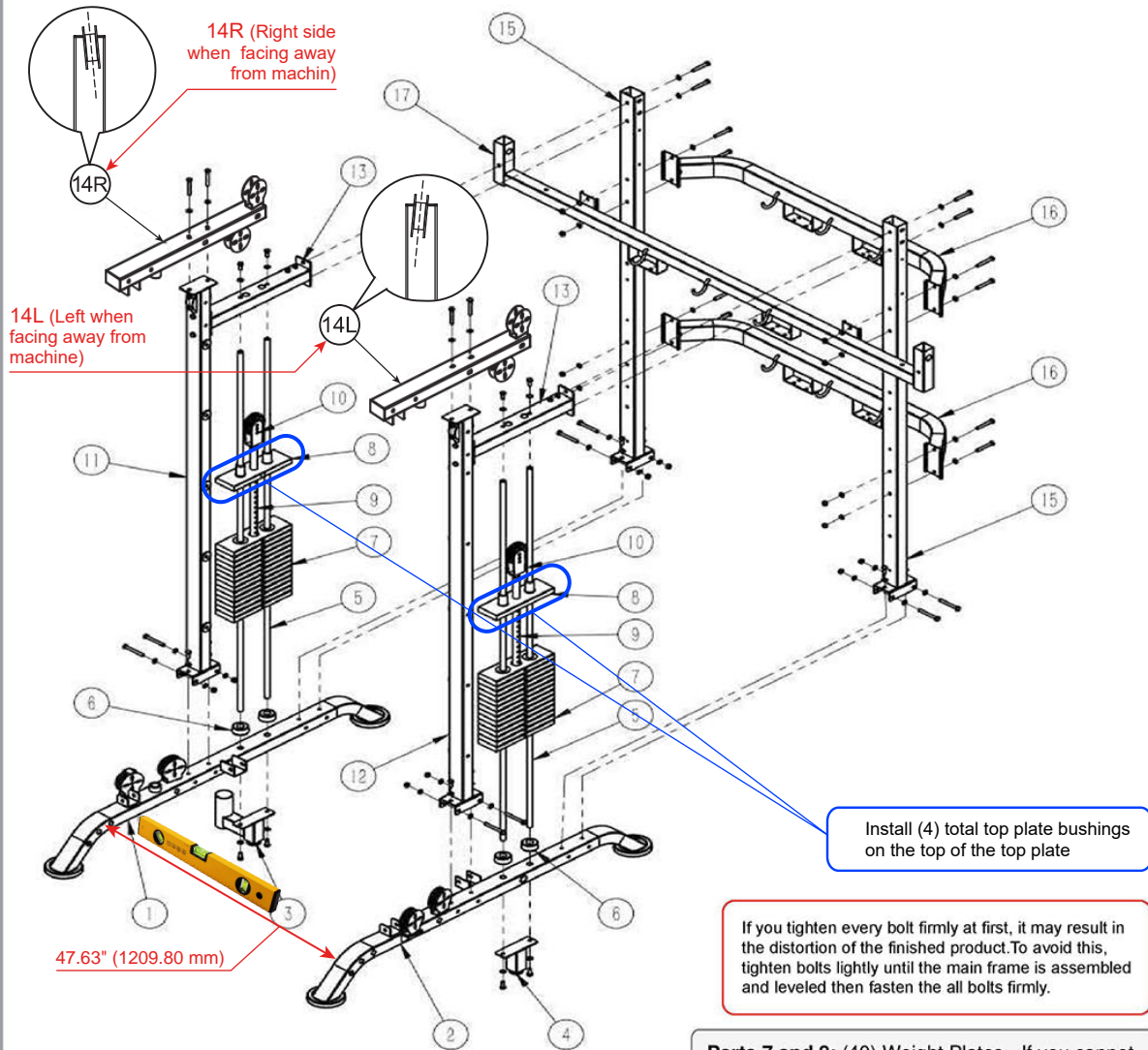

Parts 7 and 8: (40) Weight Plates - If you cannot locate, check under the crate. They are frequently packaged there

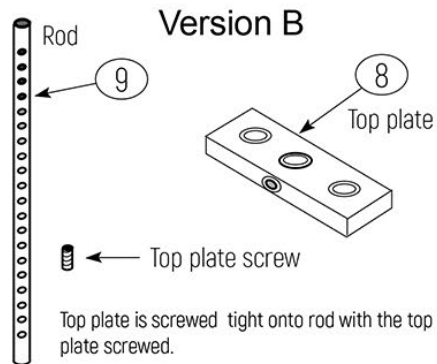
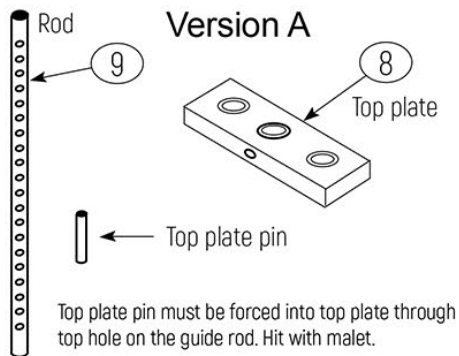

Installing Step 1 Assembling Diagram

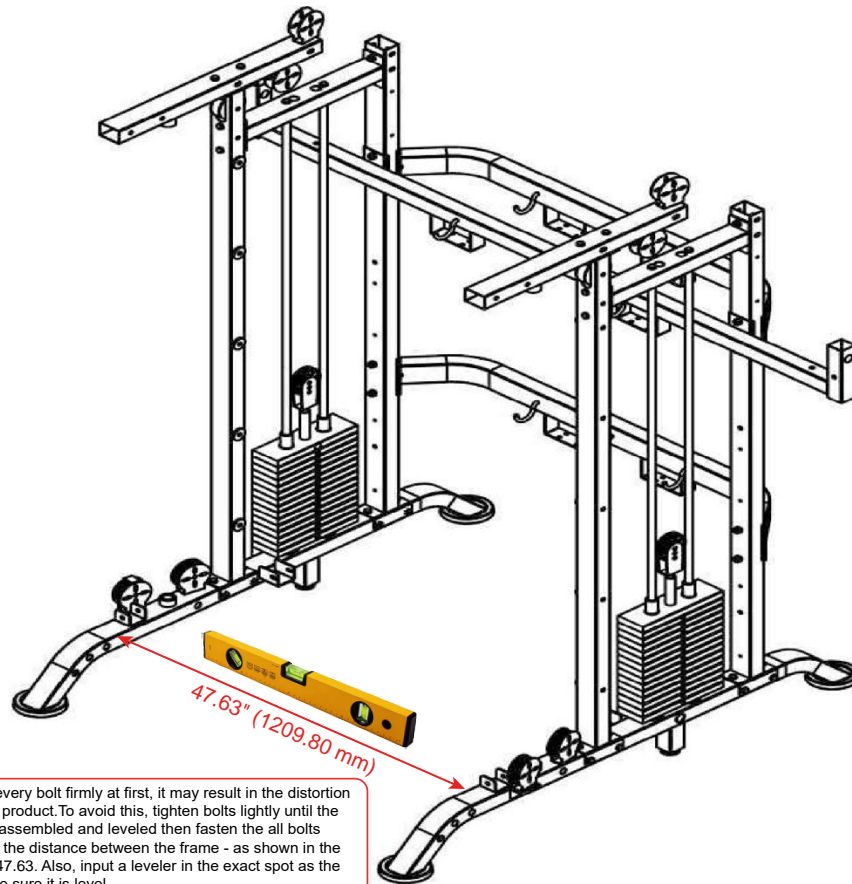

If you tighten every bolt firmly at first, it may result in the distortion of the finished product. To avoid this, tighten bolts lightly until the main frame is assembled and leveled then fasten the all bolts firmly. Be sure the distance between the frame - as shown in the pic below - is 47.63. Also, input a leveler in the exact spot as the pic shows to be sure it is level

Installing Instruction

1. Connect the left riser (11) to the left bottom tube (1) using M10*90 outer hexagonal bolts, and fasten with M10 lock nuts.
2. Connect the right riser (12) to the right bottom tube (2) using M10*90 outer hexagonal bolts, and fasten with M10 lock nuts.
3. Connect the guiding tube (5) to the left bottom tube (1), and connect the guiding tube (5) through the left bottom supporting tube (3) with M10*20 hexagonal bolts.
4. Connect the guide tube (5) to the right bottom tube (2), and connect the guiding tube (5) through the right bottom supporting tube (4) with M10*20 hexagonal bolts.
5. Install the shock absorber (6), bottom piece (7) and top piece (8) to the guiding tube (5) successively.
6. Connect the lifting rod (9) to the top piece (8) tightly. Install the adjusting wheel frame (10) on top of the lifting rod (9).
7. Install the fixing guiding tube (13) to the guiding tube (5) and fasten it with M10*20 hexagonal bolts.
8. Connect the left riser (11) with the left riser (11) and the right riser (12) with M10*70 outer hexagonal bolts, and fasten them with M10 lock nuts.
9. Connect the upper crossbeam tube (14) to the left riser (11) and the right riser (12) with M10*70 outer hexagonal bolts, and fasten them with M10 lock nuts.
10. Install the rear riser (15) on the left bottom tube (1) and right bottom tube (2) with M10*90 outer hexagonal bolts, and fasten them with M10 lock nuts.
11. Connect the rear riser (15) to the fixing guiding tube (13) using M10*70 outer hexagonal bolts, and tighten with M10 lock nuts.
12. Use M10*10*70 hexagonal bolts to pass through the rear connecting tube (16) and the rear riser (15), connect with the pendant tube (17), and fasten with M10 lock nuts.

WARNING

Please DO NOT proceed with assembly if the floor is not level or the frame doesn't measure as described on page 14.

If the inner frame width does not measure 47.63" +/- 1/8" (as shown in the picture on page 14), please loosen frame bolts and push or pull the frame.

If the floor is not level (as shown in the picture on page 14), then the options are:

- placement elsewhere
- turning the machine at a different angle
- raising the proper area on the floor so the feet sit level with the rest if the feet (use a leveler on the smith bar in this case)

**FAILURE TO DO THIS WILL RESULT IN DISTORTION
OF THE SMITH MACHINE CAUSING IT
TO NOT GLIDE PROPERLY**

Installing Step 2 Exploded Diagram

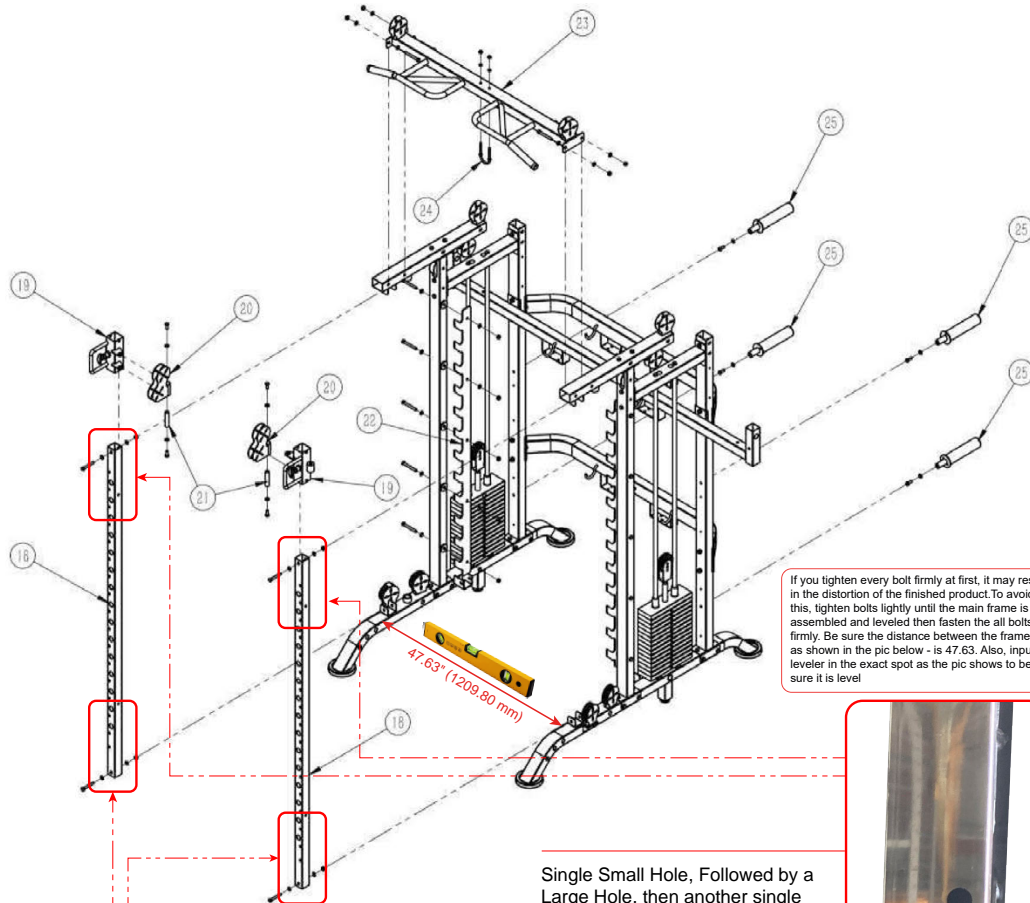

If you tighten every bolt firmly at first, it may result in the distortion of the finished product. To avoid this, tighten bolts lightly until the main frame is assembled and leveled then fasten the all bolts firmly. Be sure the distance between the frame - as shown in the pic below - is 47.63. Also, input a leveler in the exact spot as the pic shows to be sure it is level

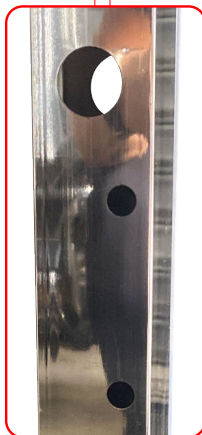

Double Small Hole Pattern at Bottom of Cable Columns Facing Out. Also, make sure double holes are on the outer (not inner) part of the machine - so for the right column, on the right side... and for the left column, on the left side.

Single Small Hole, Followed by a Large Hole, then another single Hole, at Top of Cable Columns facing out. Also, make sure double holes are on the outer (not inner) part of the machine - so for the right column, on the right side... and for the left column, on the left side.

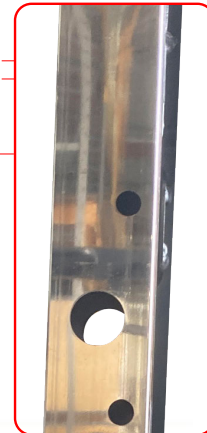

If you tighten every bolt firmly at first, it may result in the distortion of the finished product. To avoid this, tighten bolts lightly until the main frame is assembled and leveled then fasten the all bolts firmly.

Installing Step 2 Assembling Diagram

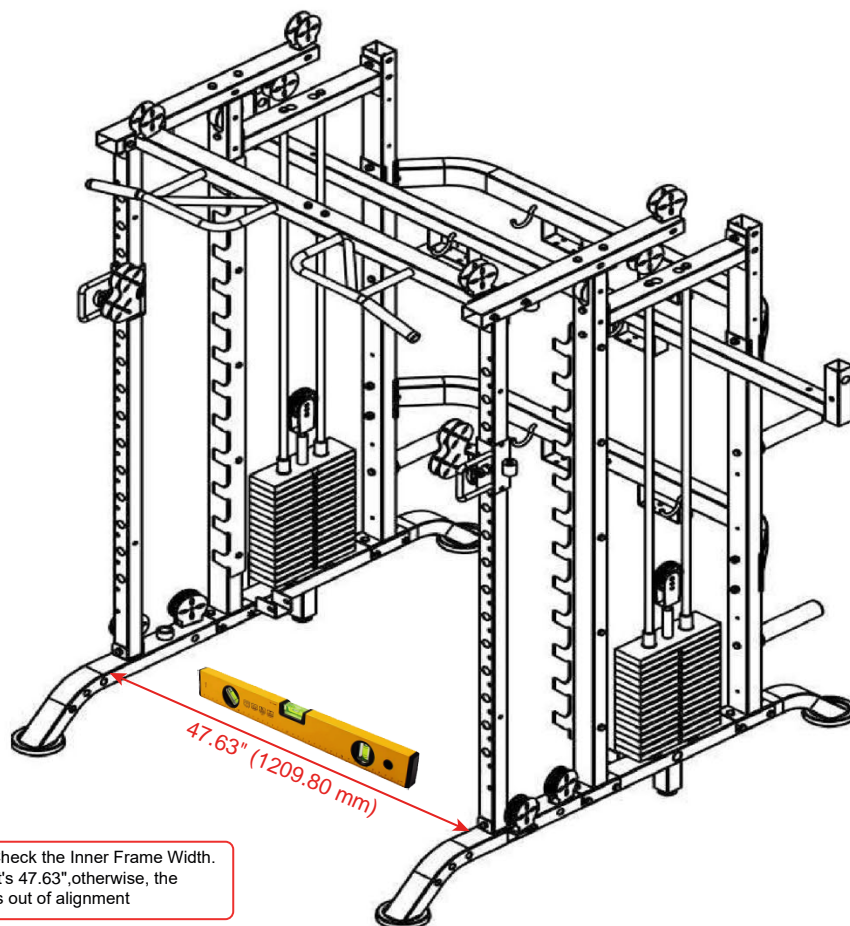

Double Check the Inner Frame Width.
Be sure it's 47.63", otherwise, the
product is out of alignment

Installation Instruction

1. Connect the adjusting sleeve tube (19) to the adjusting tube (18).
2. Install the adjusting tube (18) on the left bottom tube (1) and right bottom tube (2) with M10*70 outer hexagonal bolts, and fasten them with M10 lock nuts.
3. Connect the adjusting tube (18) with the upper horizontal tube (14) with M10*70 hexagonal bolts, and tighten with M10 lock nuts.
4. Connect the pulley frame (20) with the adjusting sleeve tube (19) using the rotating shaft (21), and fasten with M10 hexagonal bolts.
5. Install the hook plate (22) on the left riser (11) and right riser (12) using M10*90 outer hexagon bolts, and fasten them with M10 lock nuts.
6. Connect both sides of the upper crossbeam tube (23) with the upper cross tube (14) using M10*70 outer hexagonal bolts, and fasten with M10 lock nuts.
7. Connect the sandbag hook (24) to the upper crossbeam tube (23), and fasten it with an M8 lock nut.
8. Connect the hanger tube (25) to the rear riser (15), and fasten with M10*20 hexagonal bolts.

Installing Step 3 Exploded Diagram

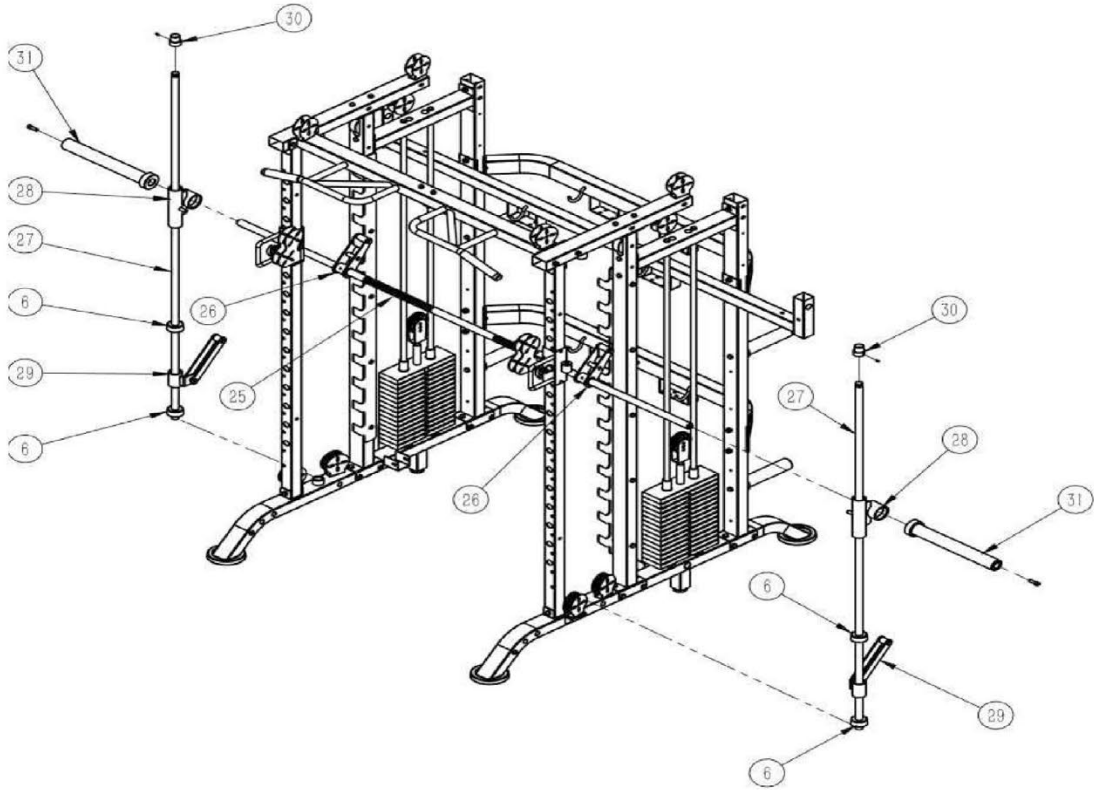

Installing Step 3 Assembling Diagram

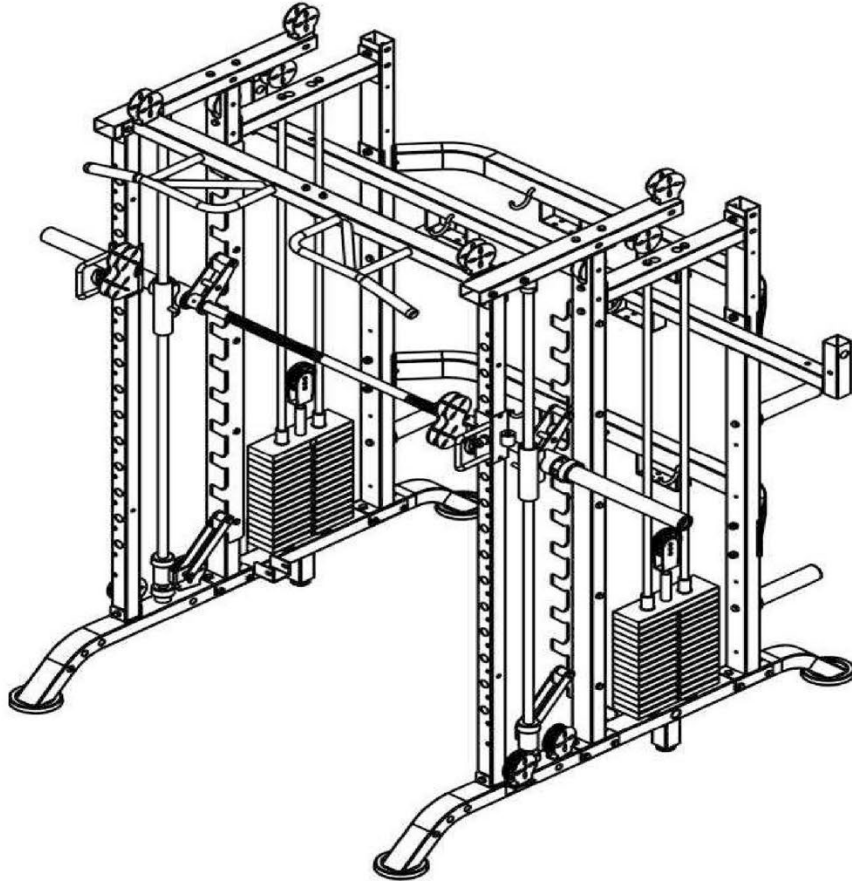

Installation Instruction

1. Connect the Olympic barbell hook (26) to the Olympic barbell (25) and fasten with M8 inner hexagonal bolts.
2. Insert the sliding rod (27) into the shock-absorbing pad (6), safety hook (29), shock-absorbing pad (6), Olympic barbell fixing sleeve (28), and sliding rod fixing sleeve (30) successively.
3. Connect the Olympic barbell fixing sleeve (28) with the Olympic barbell (25), and connect the sliding rod fixing sleeve (30) with the upper cross tube (14), and fasten them with M8 inner hexagonal bolts.
4. Connect the Olympic barbell sleeve (31) to the Olympic barbell (25), and fasten with M12*30 inner hexagonal bolts.

Installing Step 4 Exploded Diagram

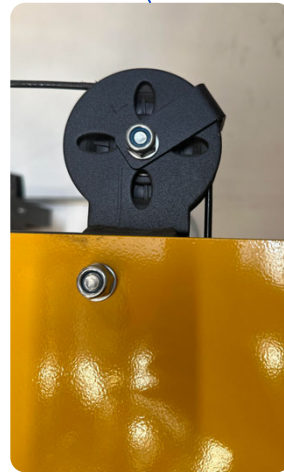
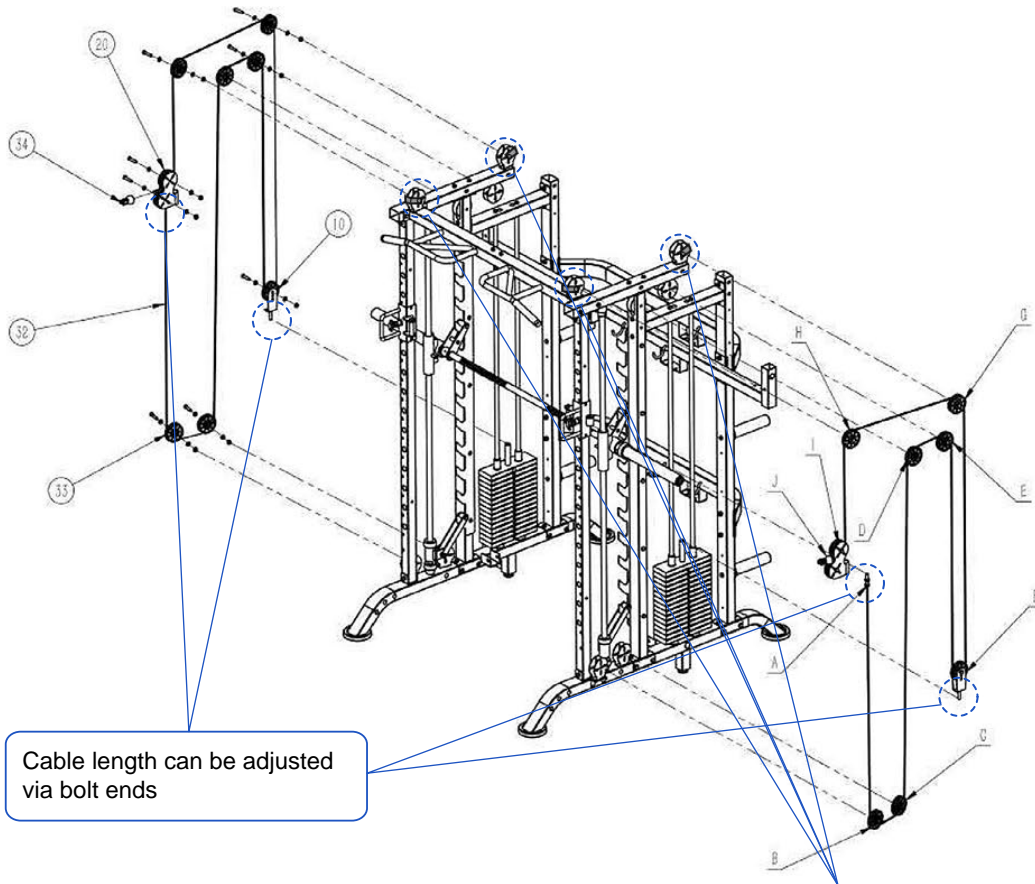

Cable (#32) = 297.75" (1 rubber ball end and 1 bolt end.)

Installing Step 4 Assembling Diagram

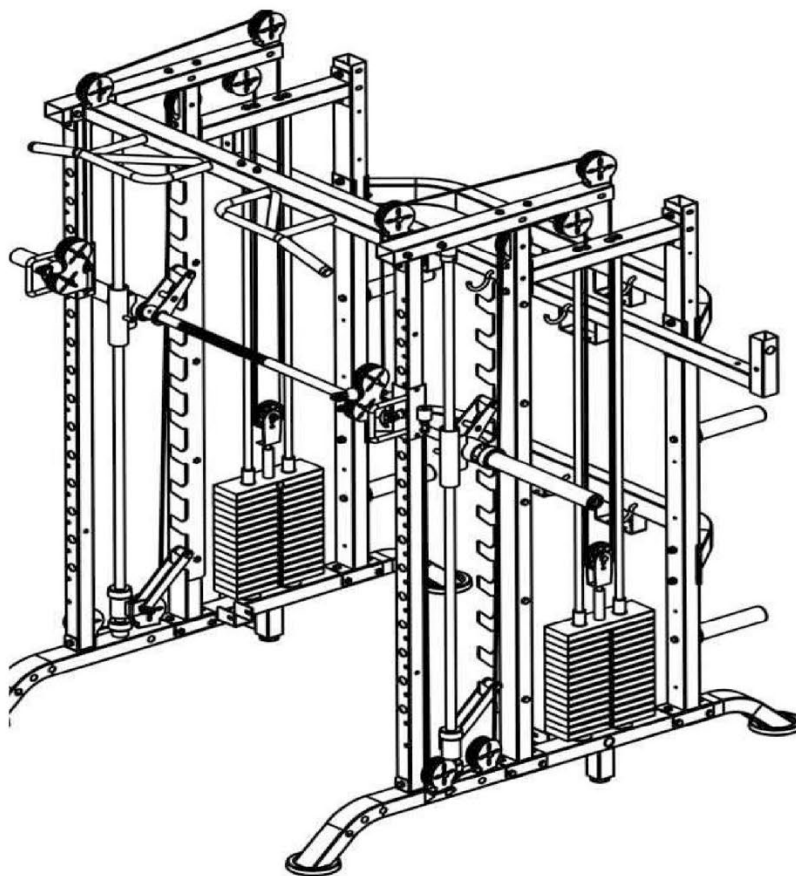

Installation Instruction

1. Connect the bolt end of the steel rope (32) to the adjusting sleeve (19).
2. Disassemble the ball end (34) of the steel rope (32), and pass it through pulley (33) B, C, D, E, F, G, H, I, J in turn, and install the ball end (34) of the steel rope at point J.

Steel rope length: 7758mm

Cable (#32) = 297.75" (1 rubber ball end and 1 bolt end.)

Installing Step 5 Exploded Diagram

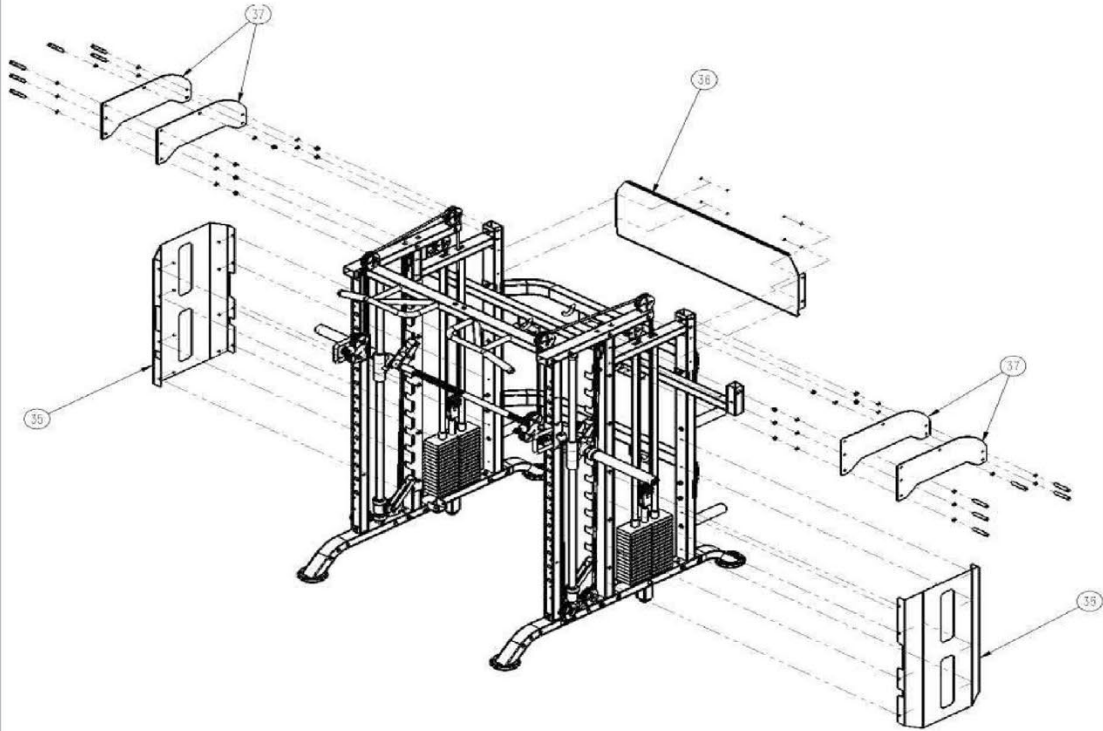

Installing Step 5 Assembling Diagram

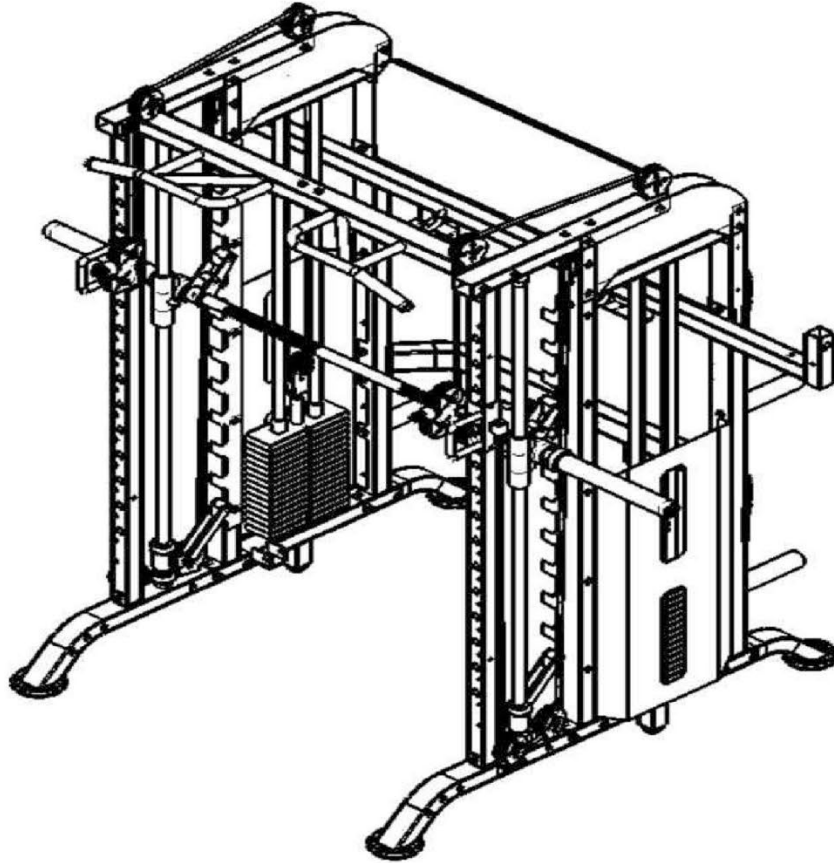

Installation Instruction

1. Pass the M10*90 outer hexagonal bolts through the connecting decorative plate (37), upper cross tube (14), rear riser (15), and connecting decorative plate (37) respectively and fasten with M10 lock nuts.
2. Pass the M10*20 outer hexagonal bolts through the guard (35) and fix them on the left riser (11) and rear riser (15) respectively.
3. Pass the M10*20 outer hexagonal bolts through the labeling plate (36) and fix it on the rear riser (15).

Installing Step 6 Exploded Diagram

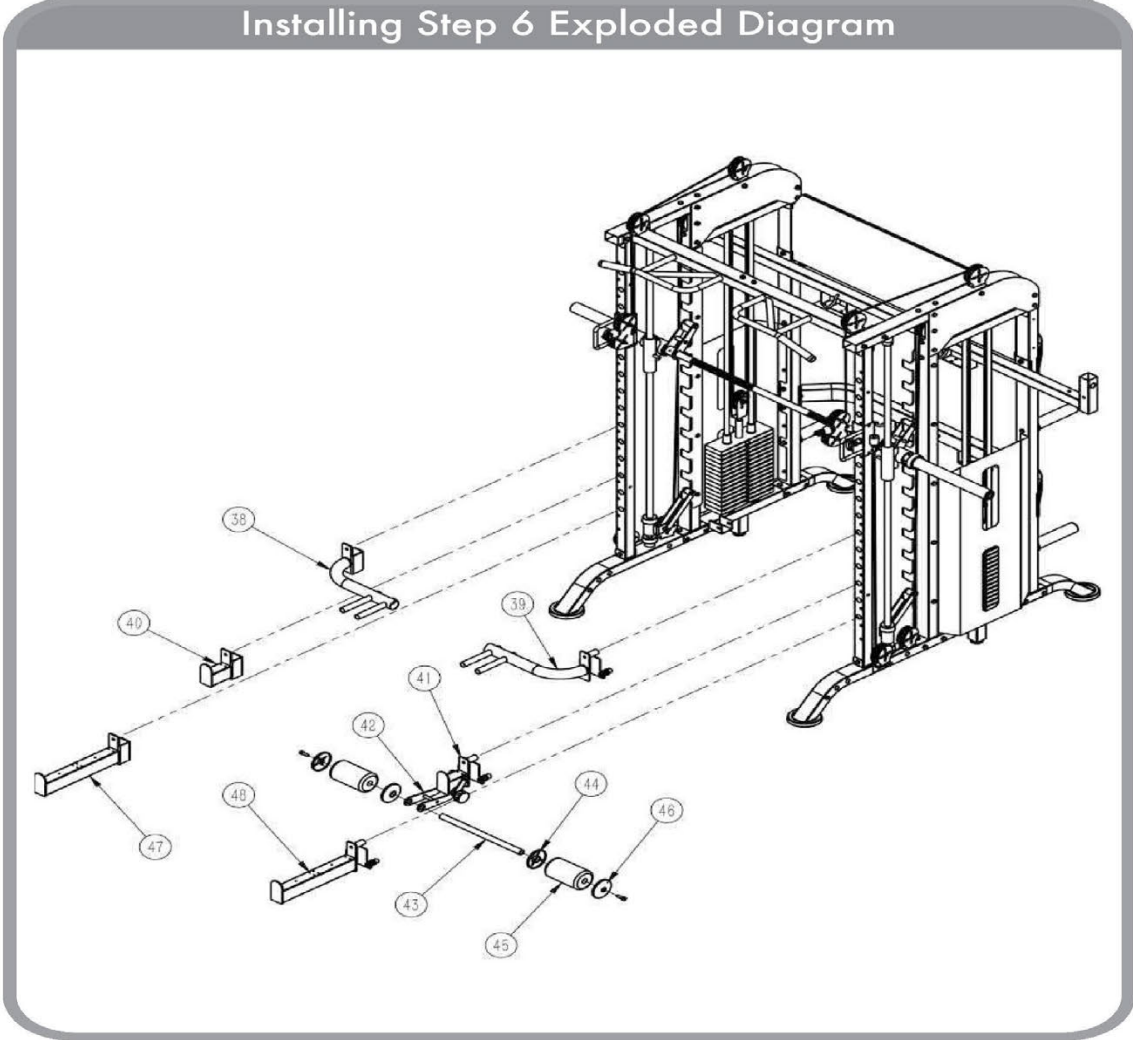

Installing Step 6 Assembling Diagram

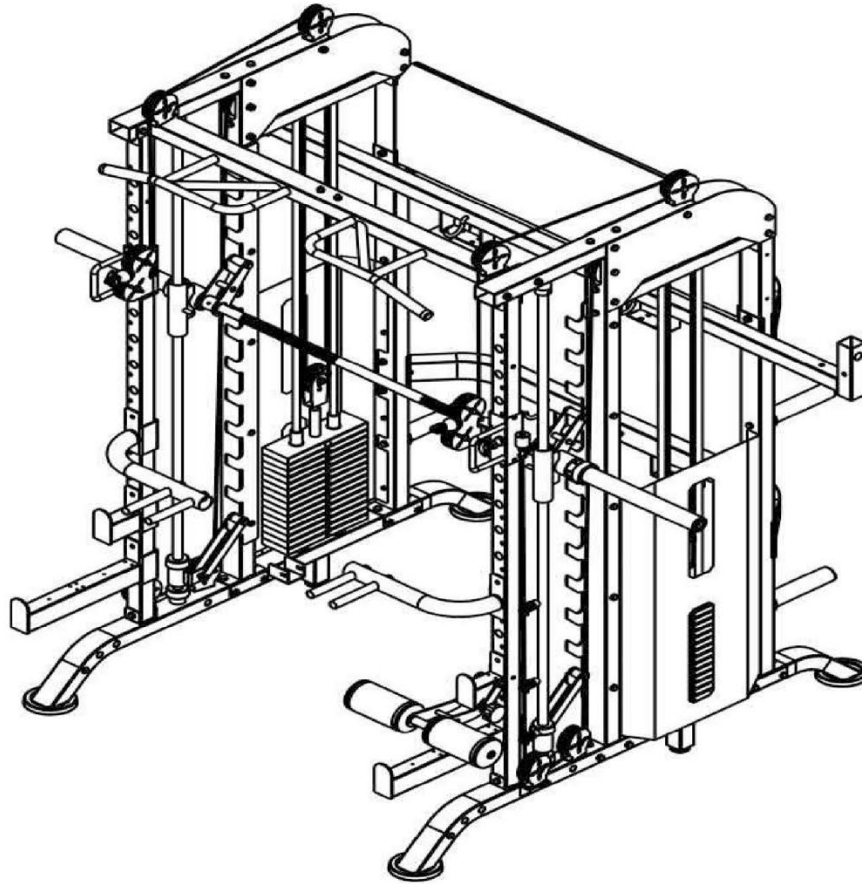

Installation Instruction

1. Install the parallel bars-left (38) and parallel bars-right (39) to the adjusting tube (18).
2. Install the Olympic barbell hook-left (40) and the Olympic barbell hook-right (41) on the adjusting tube (18) respectively.
3. Install the supine support (42) on the Olympic barbell hook-right (41), and install the foam tube (43) through the foam inner cap (44), foam (45), and foam outer cap in turn (46), and fasten with M8*20 inner rounded head bolt.
4. Install the Olympic barbell protection frame tube-left (47) and the Olympic barbell protection frame tube-right (48) on the adjusting tube (18) respectively.

Installing Step 7 Exploded Diagram

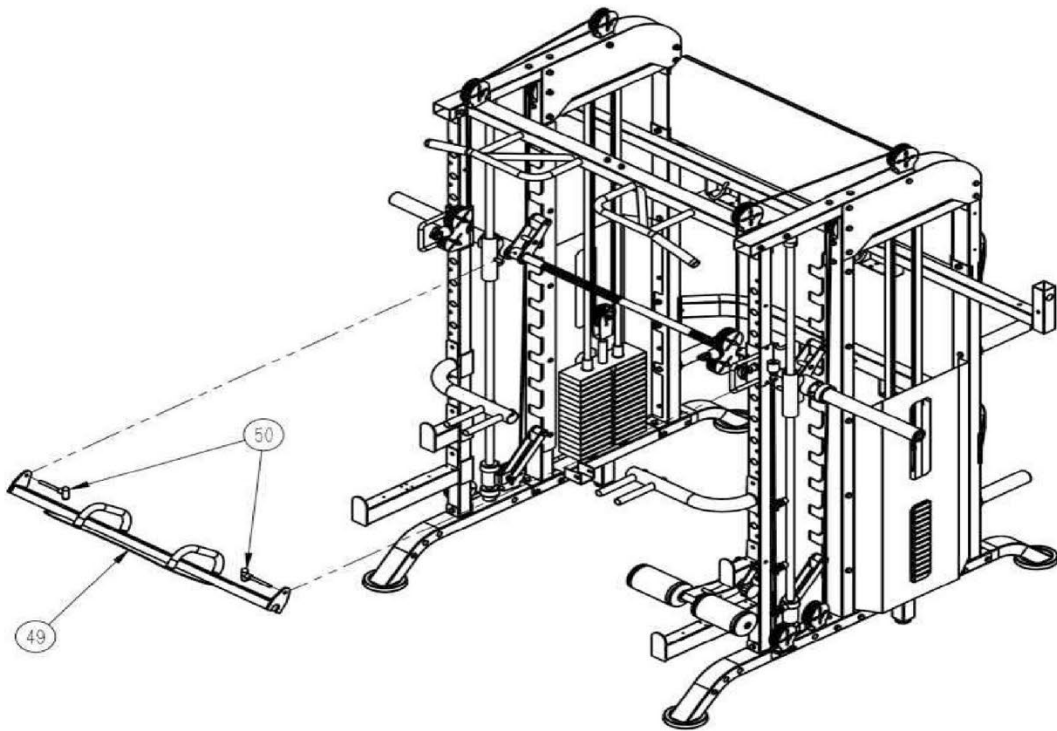

Installing Step 7 Assembling Diagram

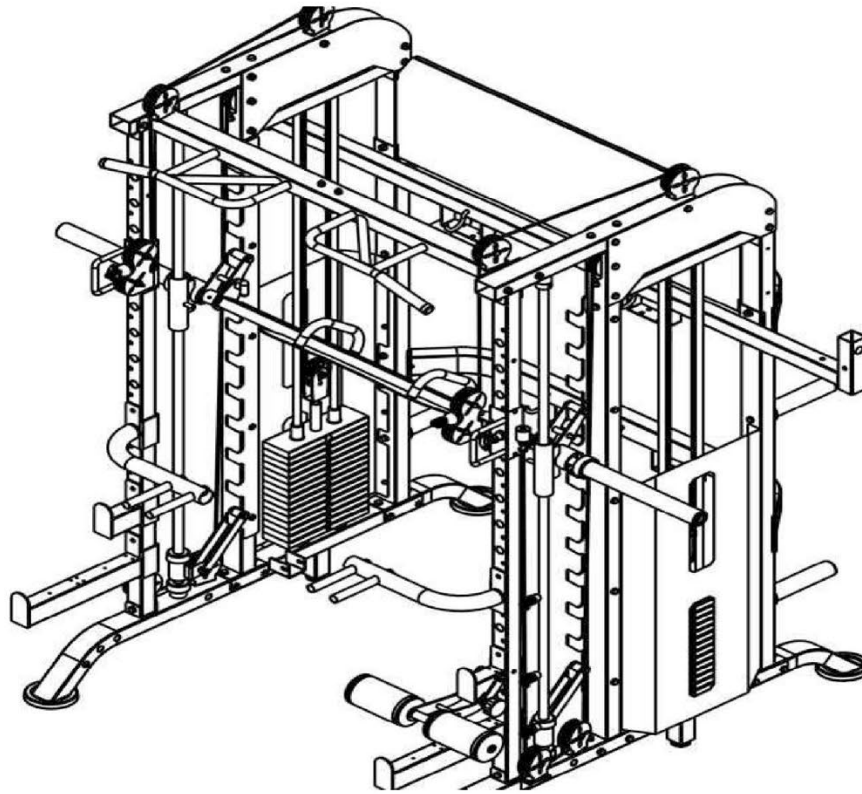

Installation Instruction

1. Connect the reverse pedal (49) to the Olympic barbell fixing sleeve (28), and fix it with the bolt (50)

Installing Step 8 Exploded Diagram

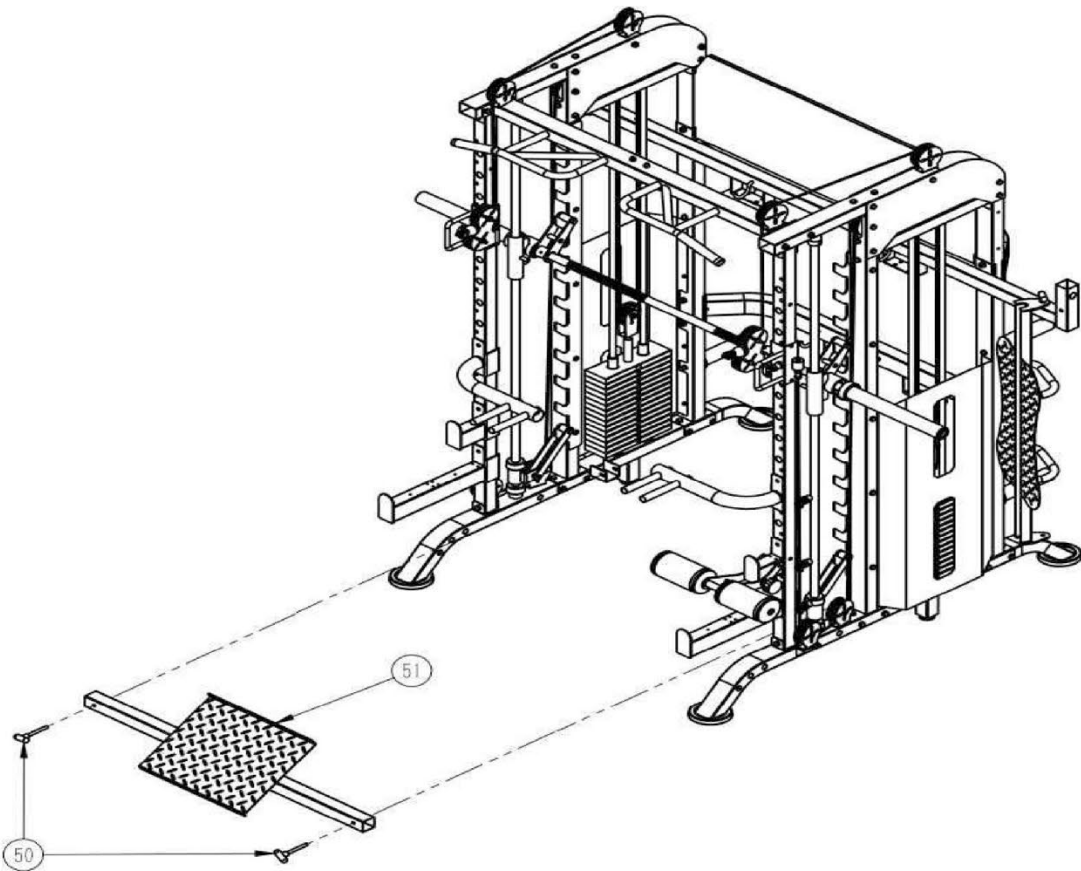

Installing Step 8 Assembling Diagram

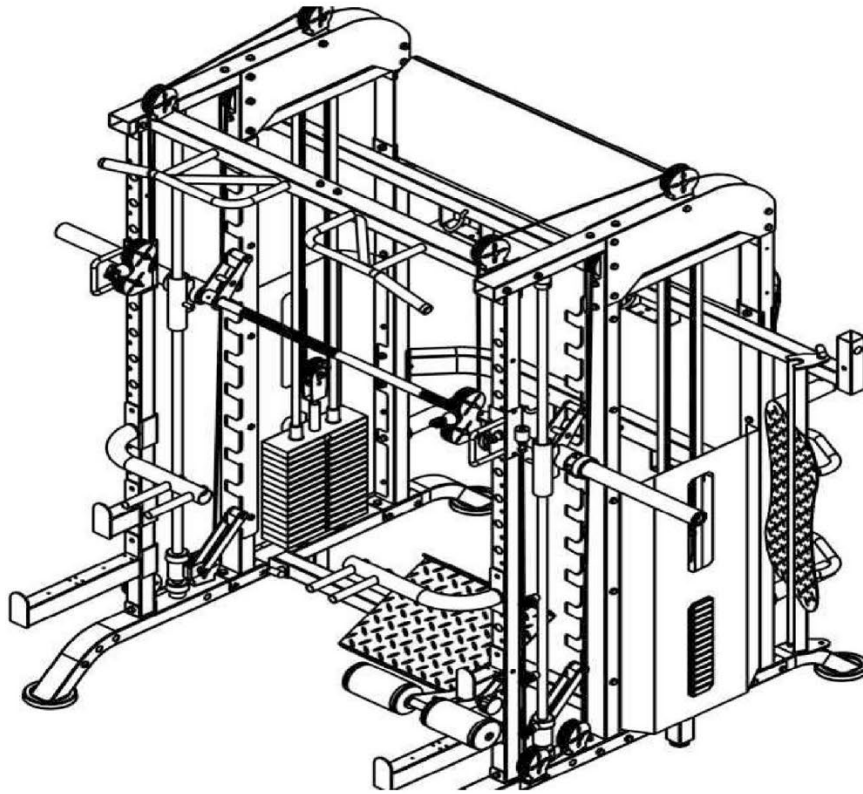

Installation Instruction

1. Connect the auxiliary foot pedal (51) to the left bottom tube (1) and the right bottom tube (2), and fix with the bolt (50).

Installing Step 9 Exploded Diagram

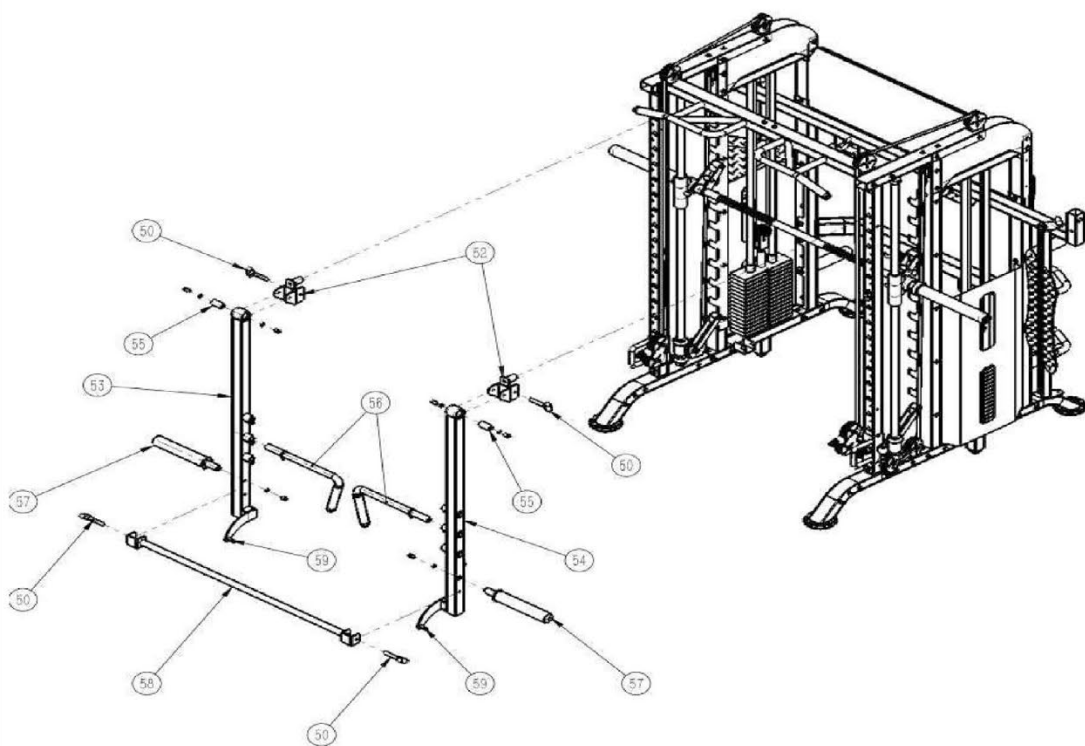

Installing Step 9 Assembling Diagram

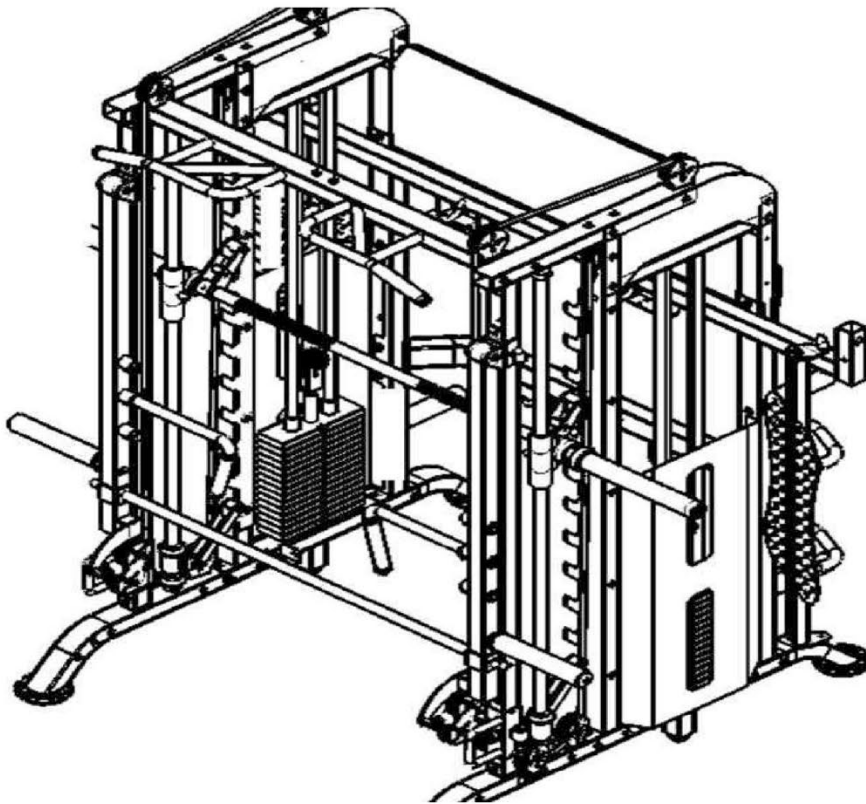

Installation Instruction

1. Connect the arm swinging connecting block (52) with the adjusting tube (18), and fix it with the bolt (50).
2. Install the arm swinging connecting shaft (55) on the arm swinging-left (53), arm swinging-right (54) and the arm swinging connecting block (52) respectively, and fasten them with M10*20 inner hexagonal bolts.
3. Install the barbell cover (57) on the arm swinging-left (53) and arm swinging-right (54) respectively with M10*20 outer hexagonal bolts.
4. Install the handles (56) on the arm swinging-left (53) and arm swinging-right (54) respectively.
5. Install the push rod (58) on the arm swinging-left (53) and arm swinging-right (54), and fix them with bolts (50).
6. Connect the connecting ring (59) to the arm swinging-left (53) and arm swinging-right (54), and connect the other end to the ball end of the steel rope (32).

FRENCH FITNESS

FF-FSR90

FRENCH FITNESS FSR90 FUNCTIONAL
TRAINER SMITH & SQUAT RACK MACHINE

EXERCISES



**SEATED
SHOULDER
PRESS**

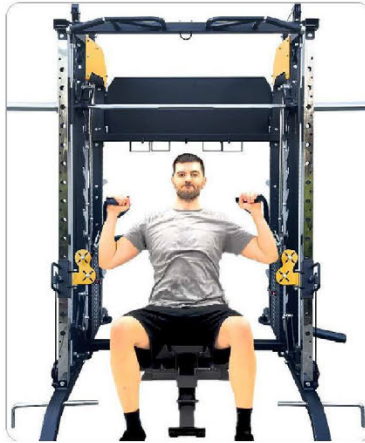

START

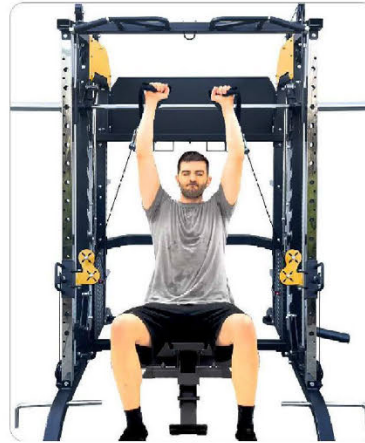

END

**INCLINE
CHEST**

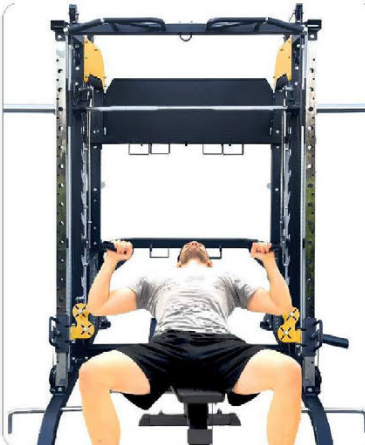

START

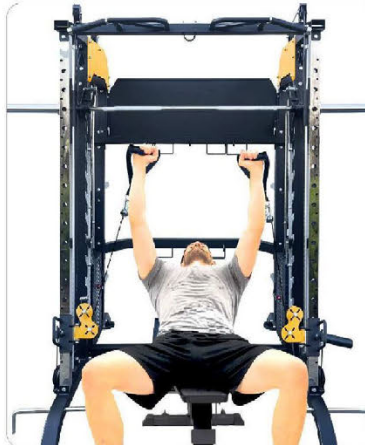

END

**INCLINE
PEC FLY**

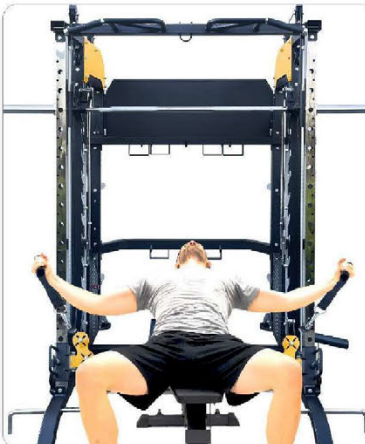

START

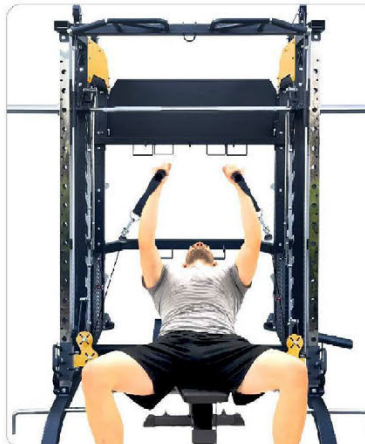

END

FLAT CHEST PRESS

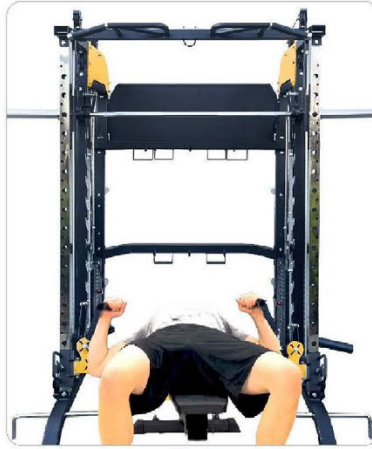

START

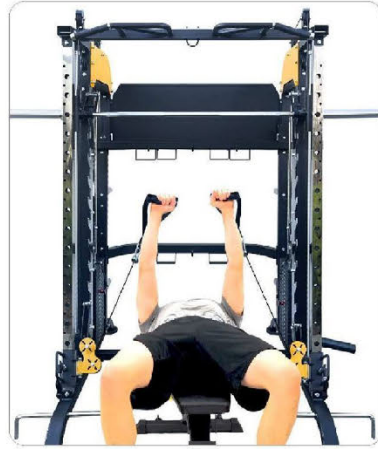

END

FLAT PEC FLY

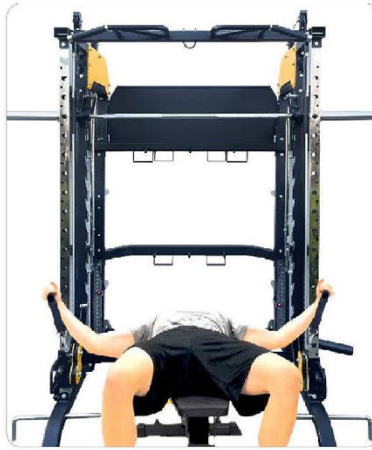

START

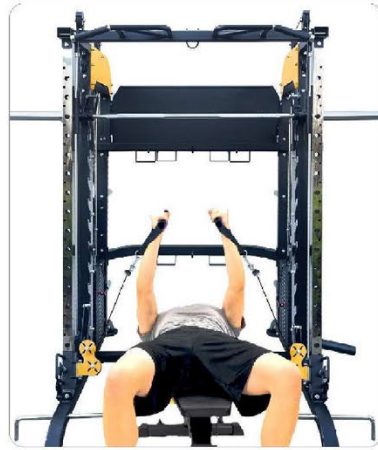

END

SEATED BICEP CURL



START

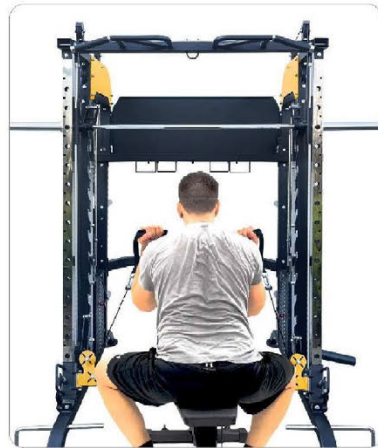

END

SEATED ROW

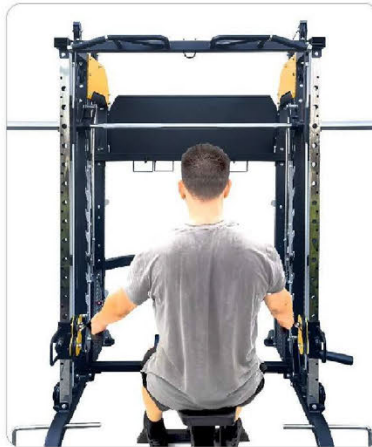

START

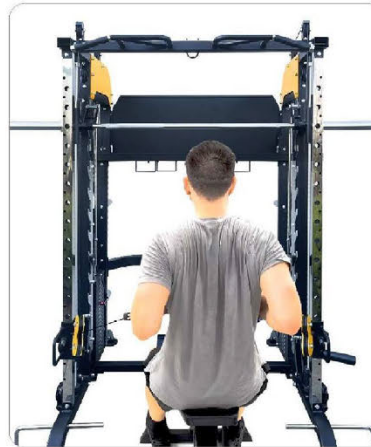

END

LATERAL RAISES

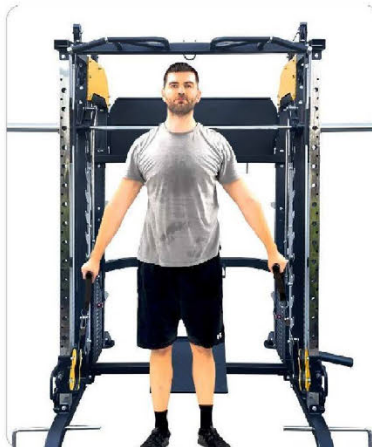

START

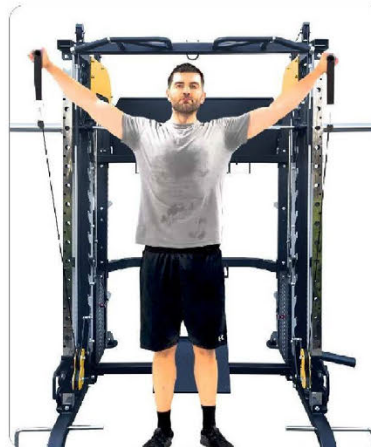

END

FRONT SHOULDER RAISES

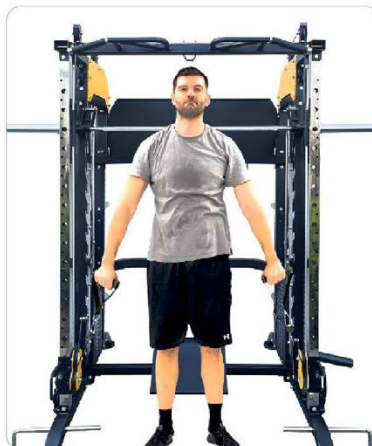

START

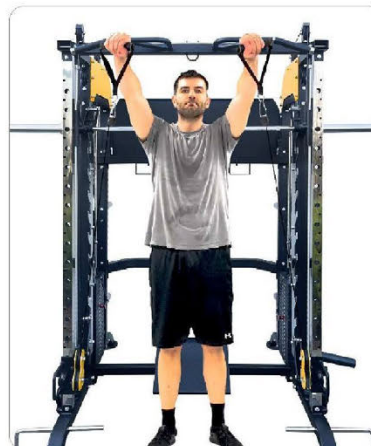

END

**BENT OVER
REAR DELT**

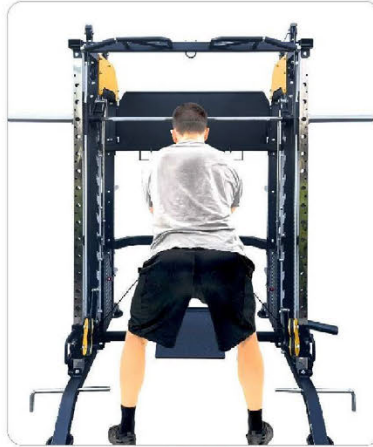

START

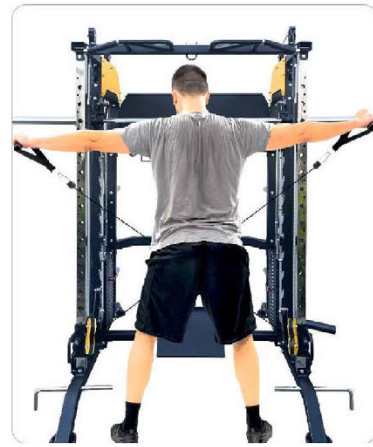

END

**ISO
LATERAL
BICEP CURL**

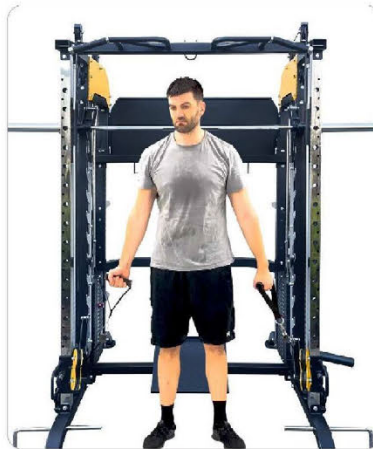

START

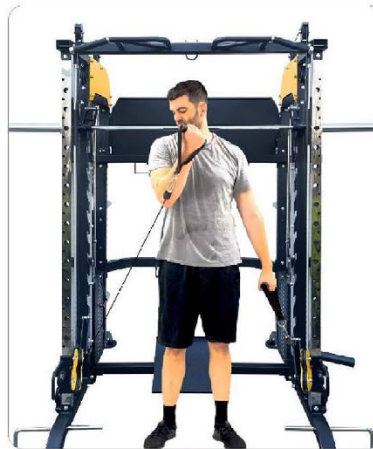

END

**STANDING
SHOULDER
PRESS**

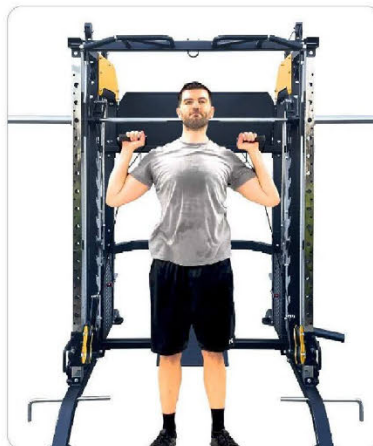

START

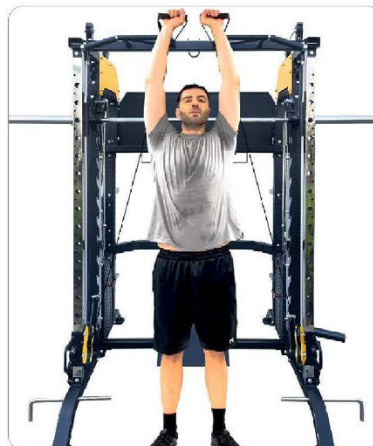

END

**STANDING
SHOULDER
SHRUGS**

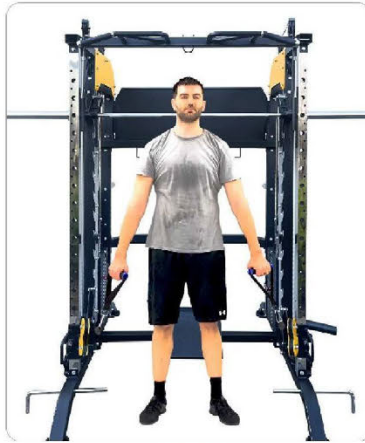

START

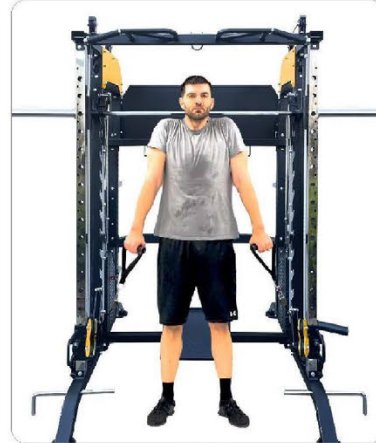

END

**STANDING
PEC FLY**

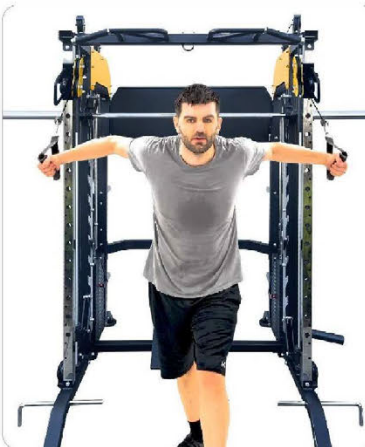

START

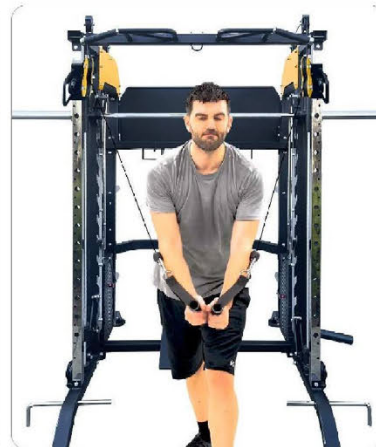

END

**STANDING
TRICEP
KICKBACKS**

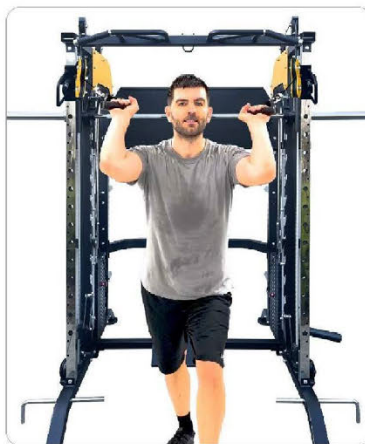

START

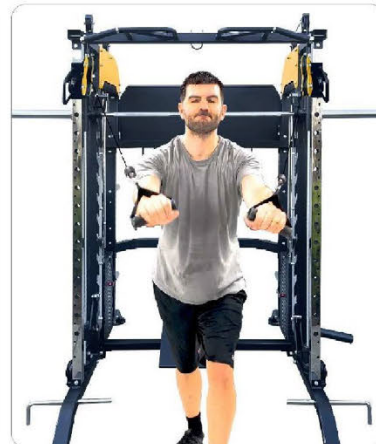

END

STRAP HANDLES (Included Attachment)

KNEELING ABDOMINAL CRUNCH

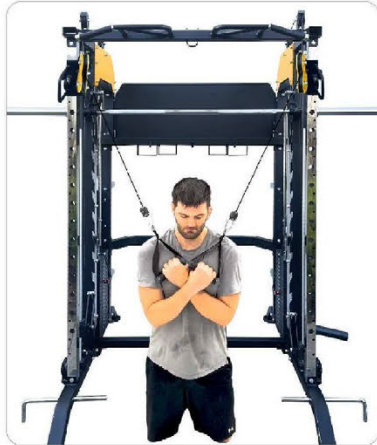

START



END

STANDING REAR DELT

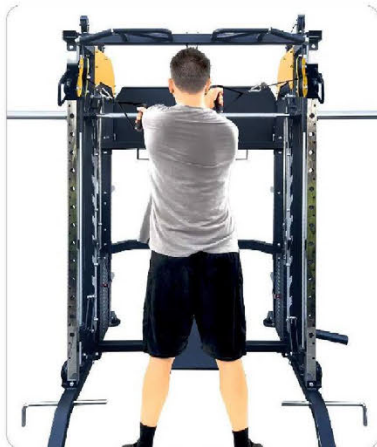

START

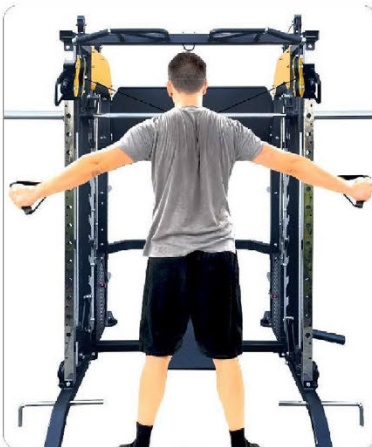

END

TRICEP ROPE (Included Attachment)

TRICEP PUSHDOWN

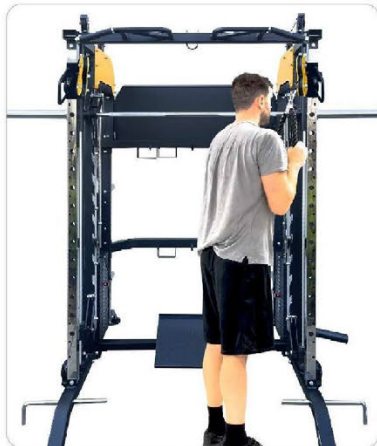

START

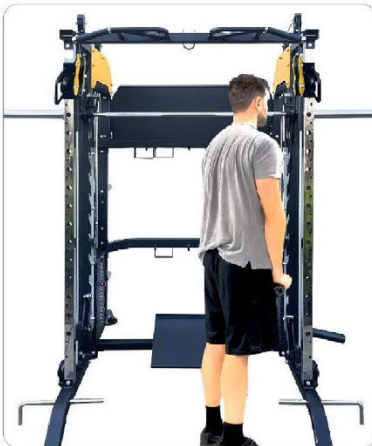

END

TRICEP ROPE (Included Attachment)

TRICEP KICKBACK

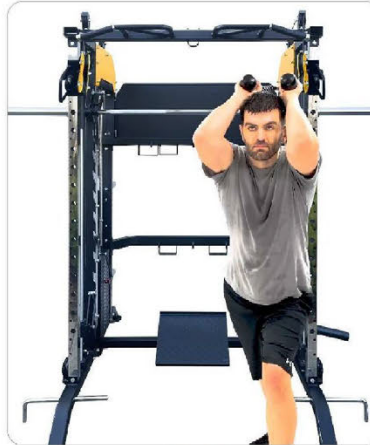

START

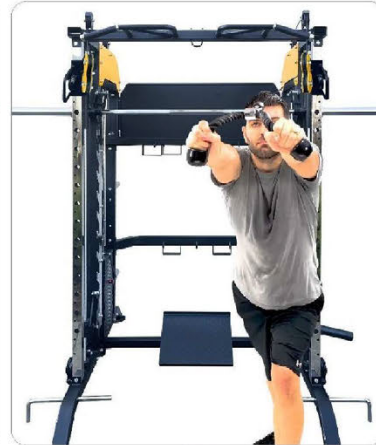

END

BICEP CURLS

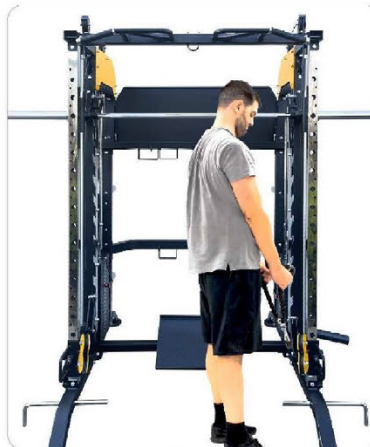

START

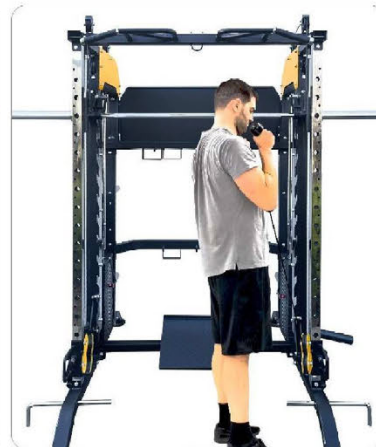

END

ANKLE CUFF (Included Attachment)

LATERAL LEG RAISES

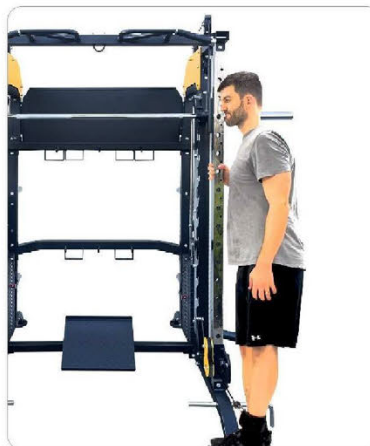

START

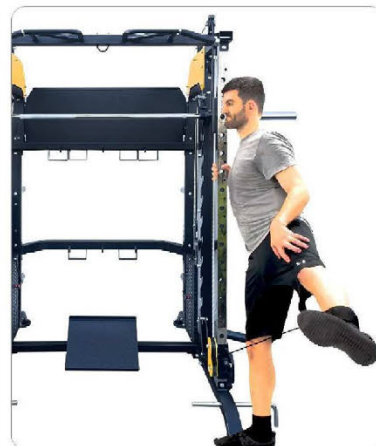

END

GLUTE KICKBACK

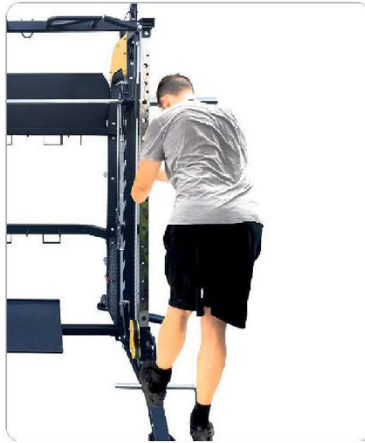

START

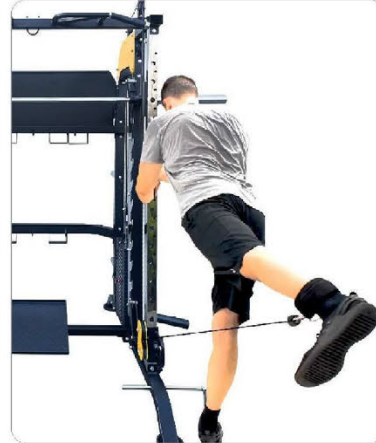

END

ONE LEGGED REVERSE LEG CURLS

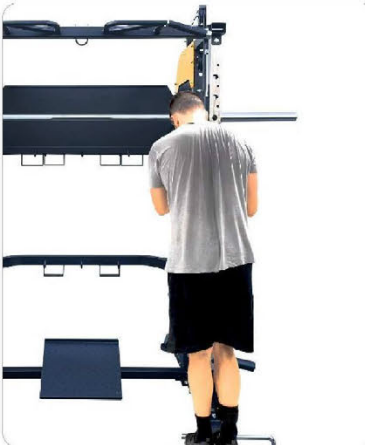

START



END

FRONT LEG RAISES



START

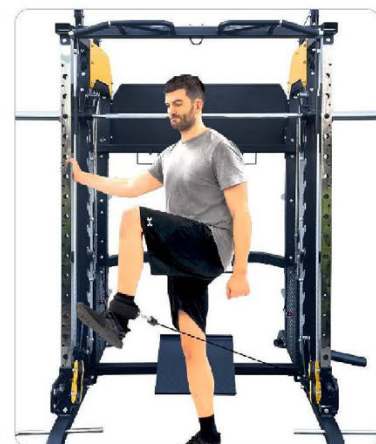

END

LAT PULLDOWN BAR / KNEE CUSHION (Included Attachment)

LAT PULLDOWN

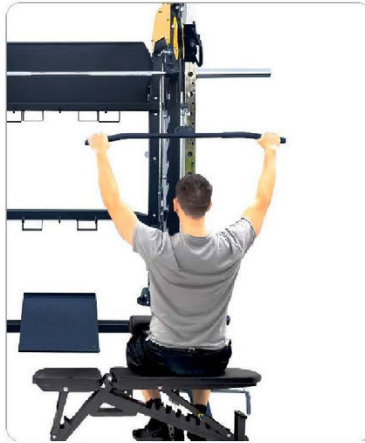

START

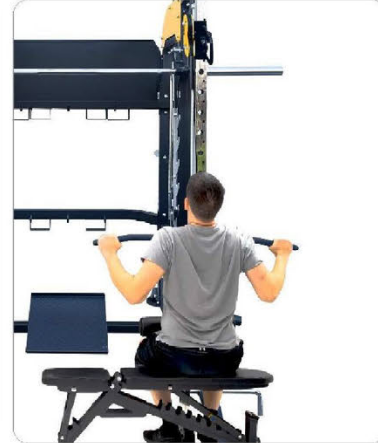

END

REVERSE GRIP LAT PULLDOWN

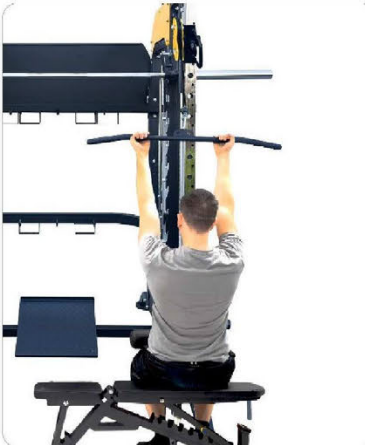

START

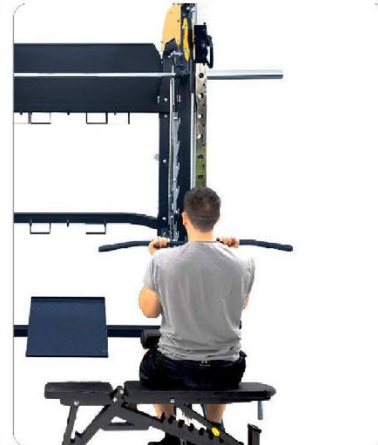

END

LEG PRESS PLATE (Included Attachment)

CALF RAISES

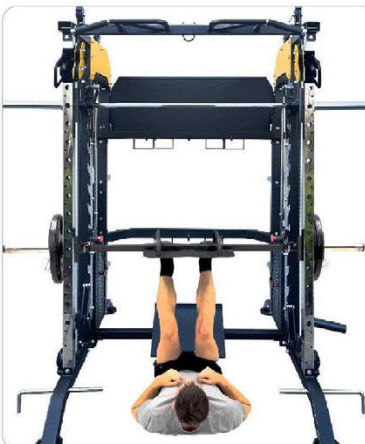

START

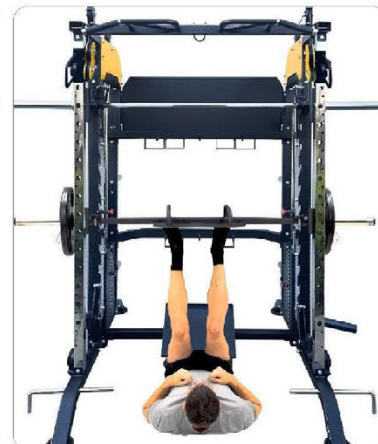

END

VERTICAL LEG PRESS

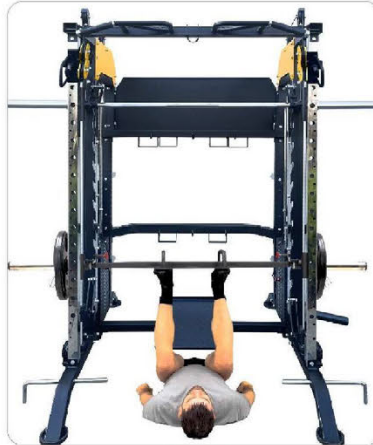

START

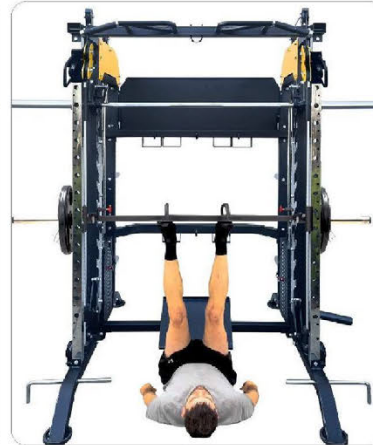

END

SEATED ROWS

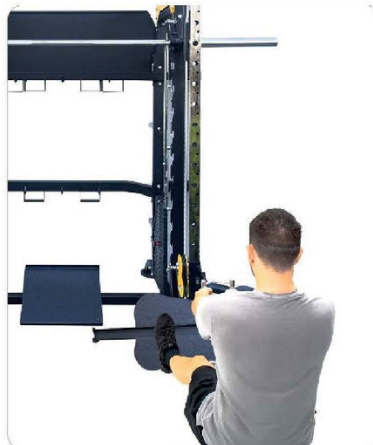

START

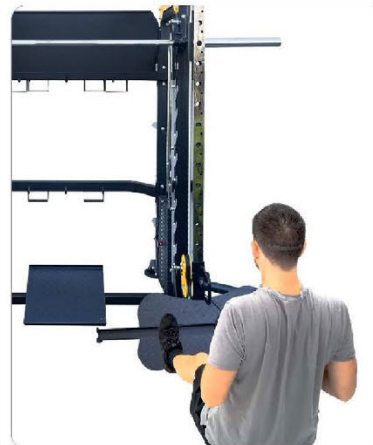

END

SQUAT

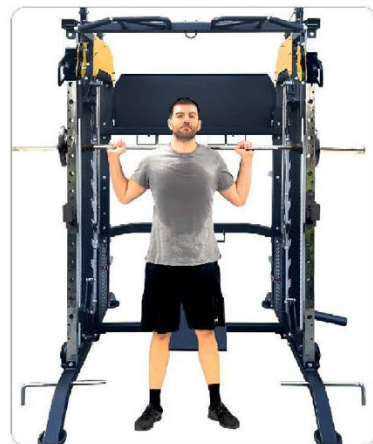

START

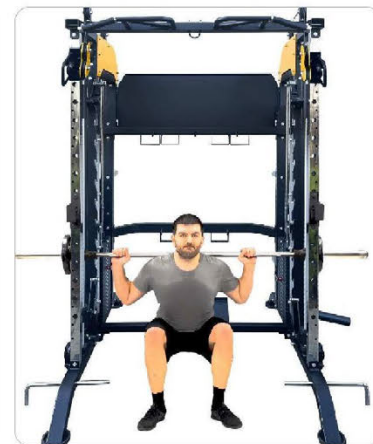

END

BENT OVER ROWS

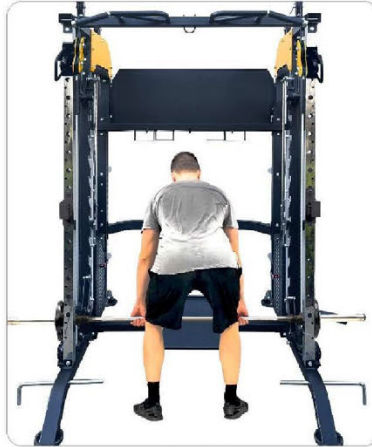

START

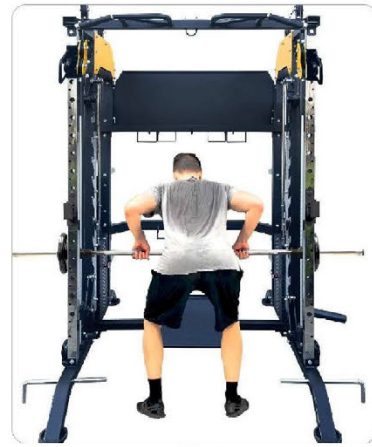

END

SHOULDER SHRUGS

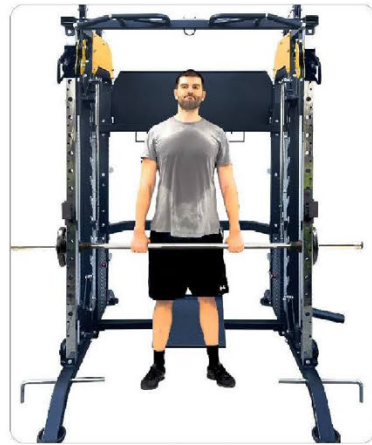

START

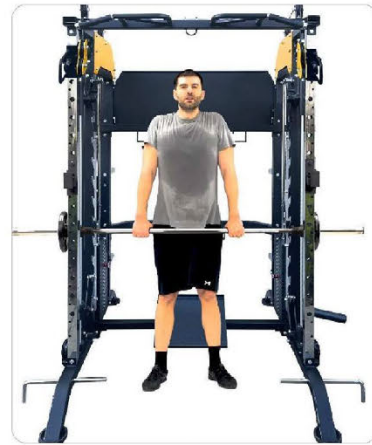

END

DEADLIFT

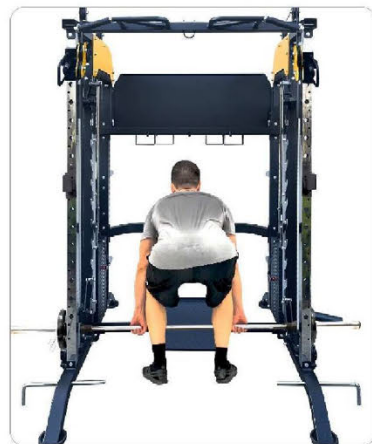

START

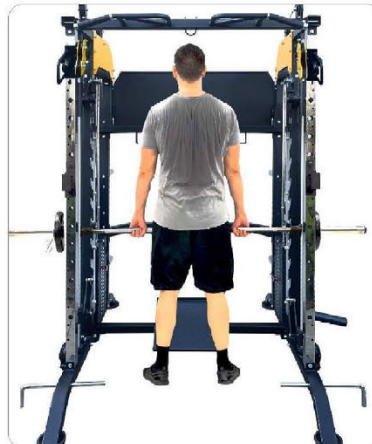

END

INCLINE CHEST PRESS



START

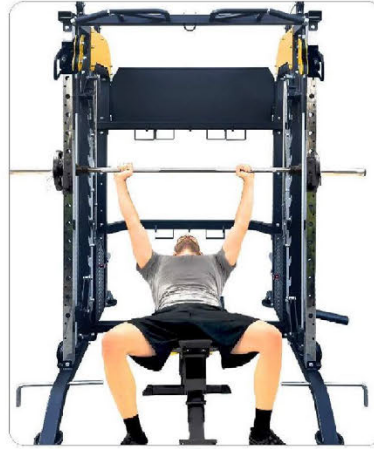

END

FLAT CHEST PRESS

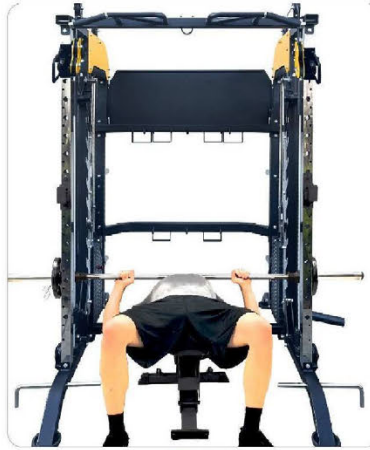

START

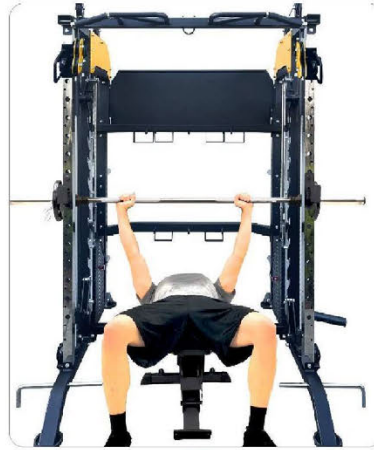

END

SUPINE ROW

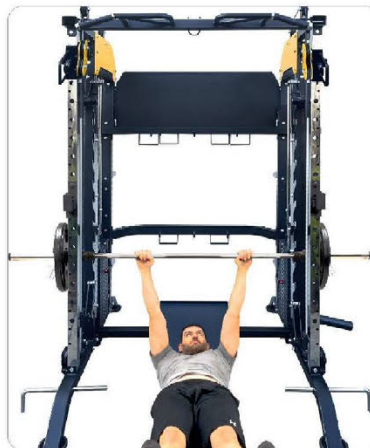

START

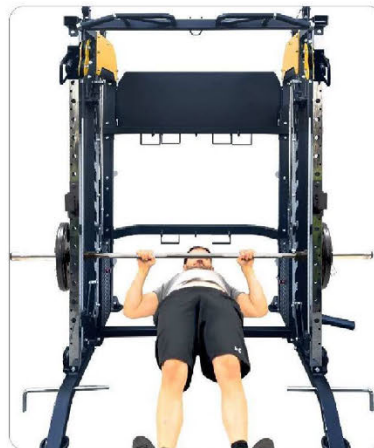

END

DIP BARS (Included Attachment)

DIPS

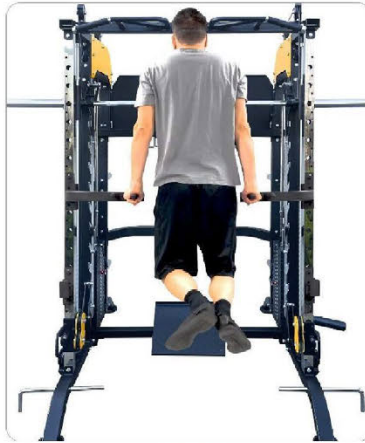

START

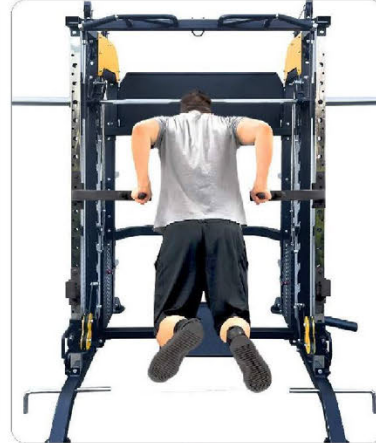

END

PULL UP BARS (Included Attachment)

CHIN UPS

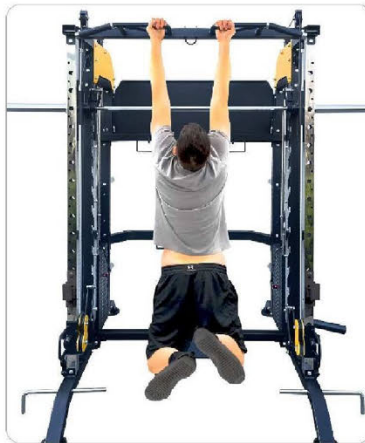

START

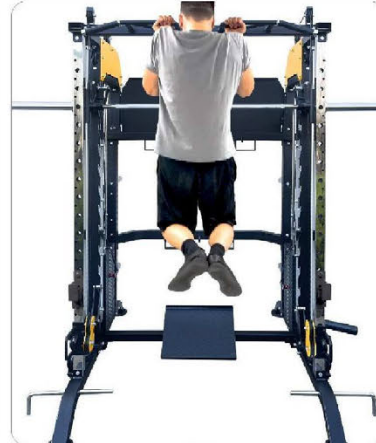

END

PULL UP

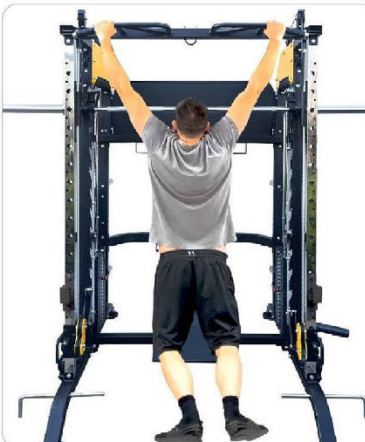

START

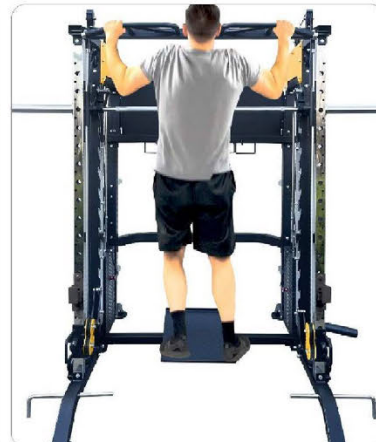

END

**TOES
TO BAR**



START

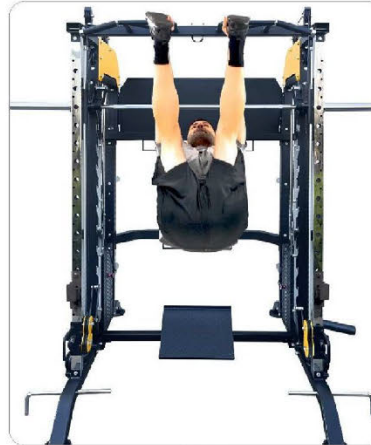

END

LEG RAISES

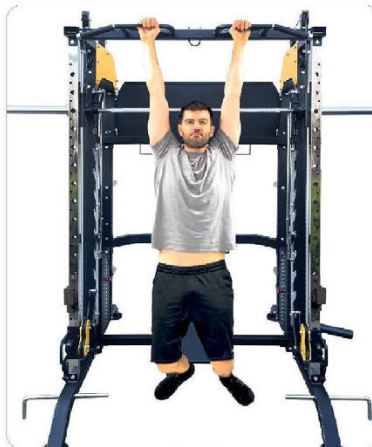

START

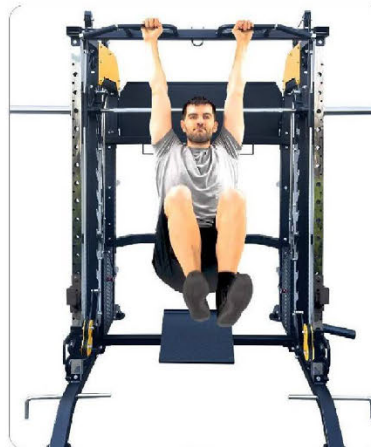

END

**KNEES TO
ELBOWS**

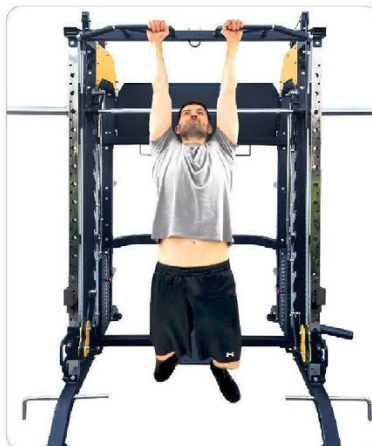

START

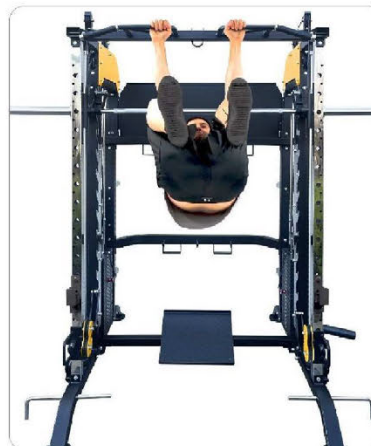

END

OVERHEAD TRICEP KICKBACKS

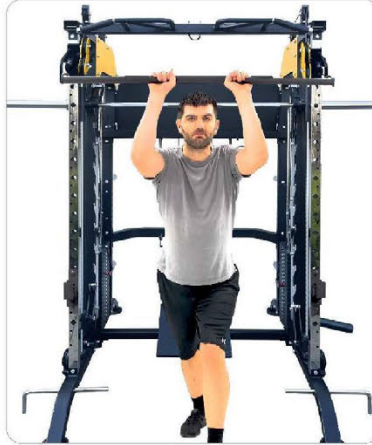

START

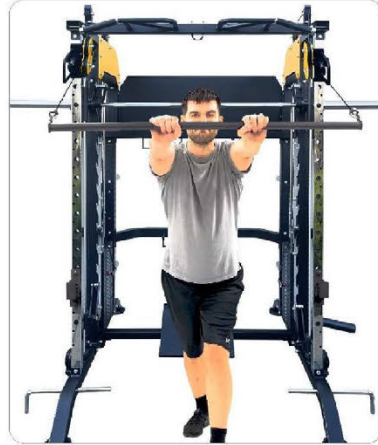

END

STANDING ROWS

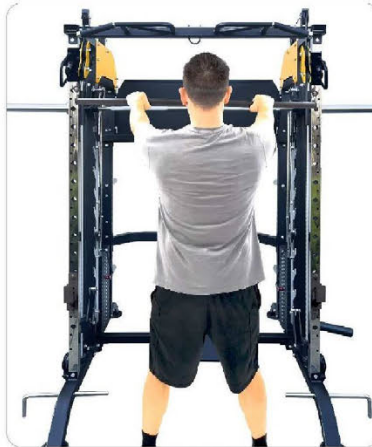

START

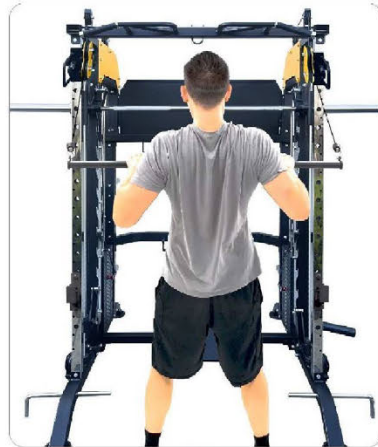

END

FLAT BENCH PRESS

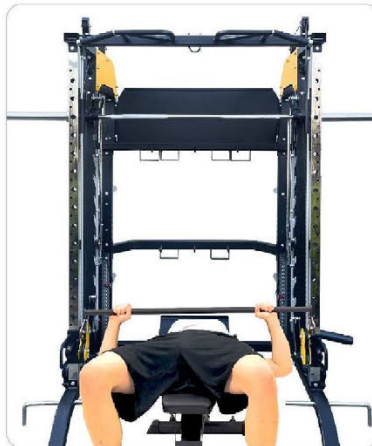

START

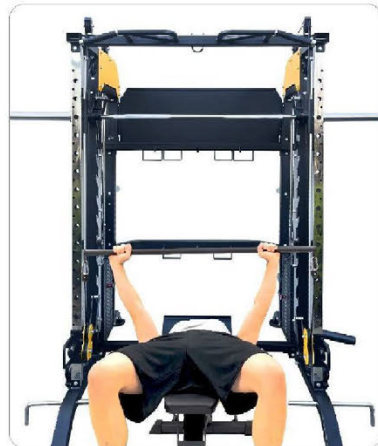

END

SKULL CRUSHERS

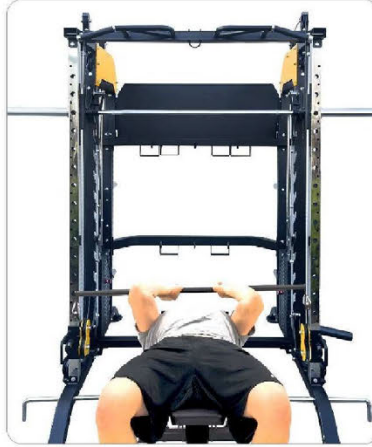

START

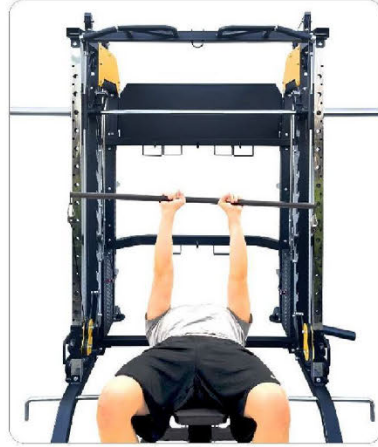

END

INCLINE BENCH PRESS

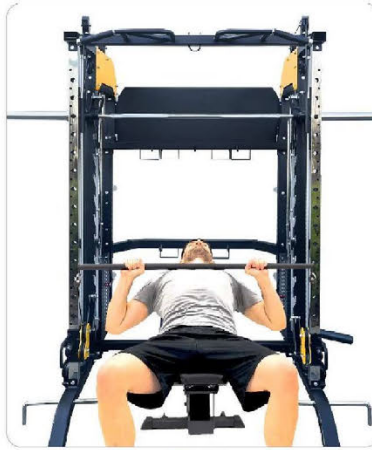

START

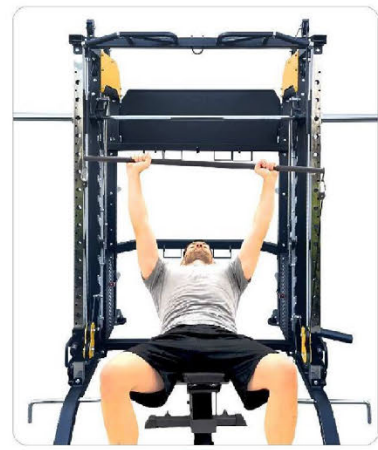

END

SEATED SHOULDER PRESS

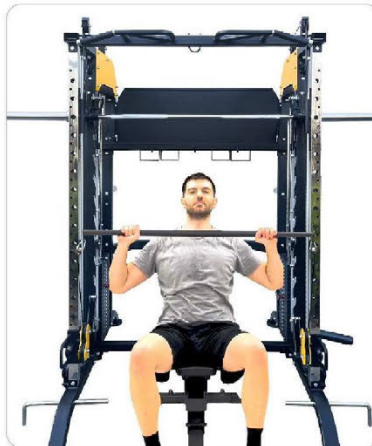

START

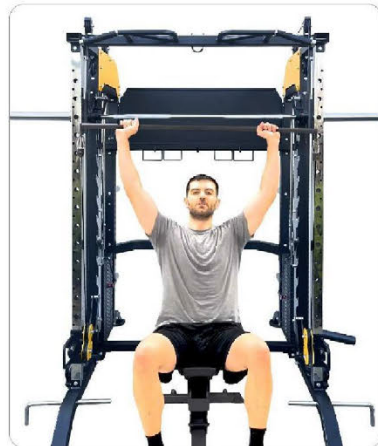

END

LAT PULLDOWNS

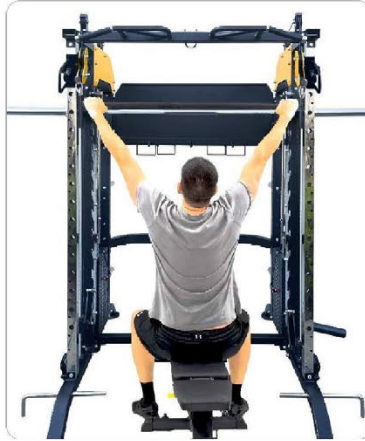

START

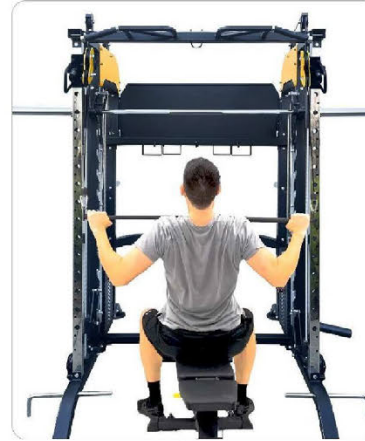

END

STANDING CHEST PRESS

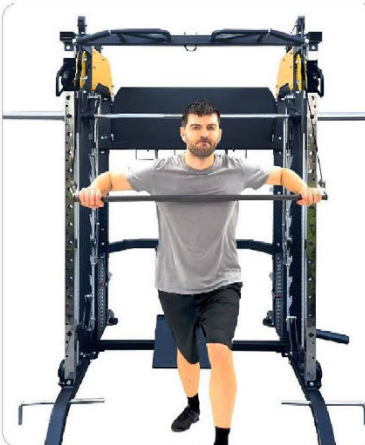

START

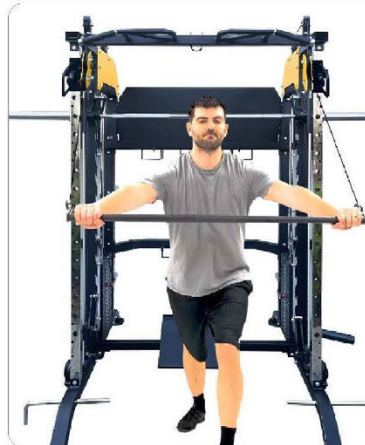

END

WIDE GRIP SEATED ROWS

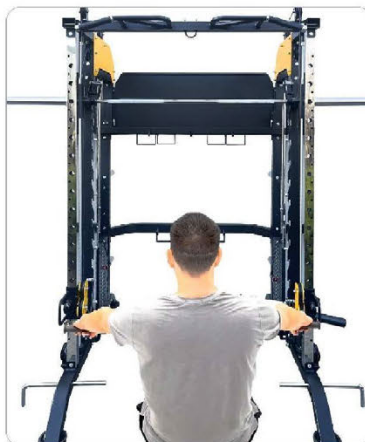

START

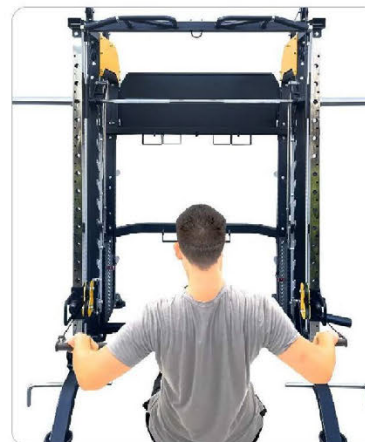

END

**REVERSE
GRIP
SEATED
ROWS**

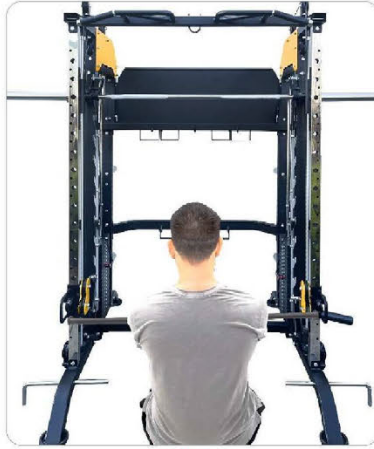

START

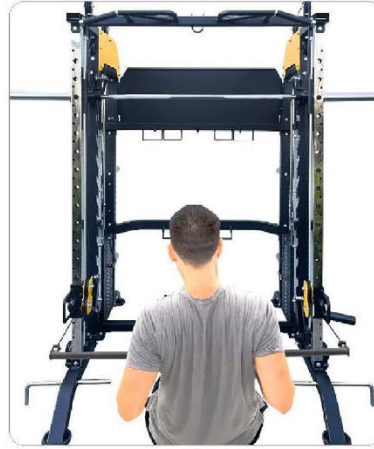

END

DEADLIFT

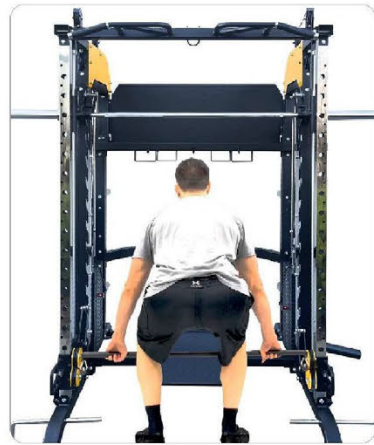

START

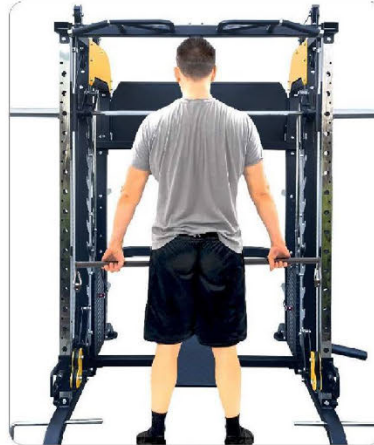

END

**UPRIGHT
ROWS**

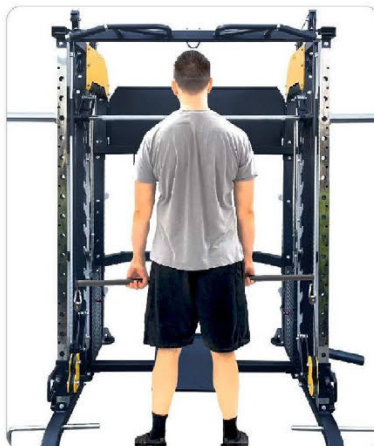

START

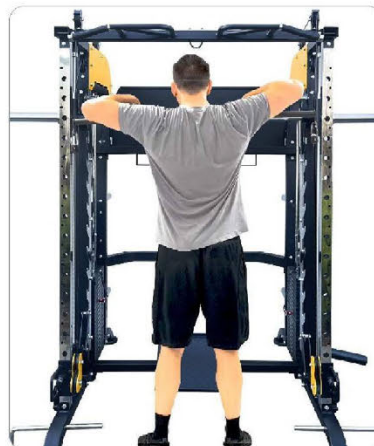

END

BENT OVER ROWS

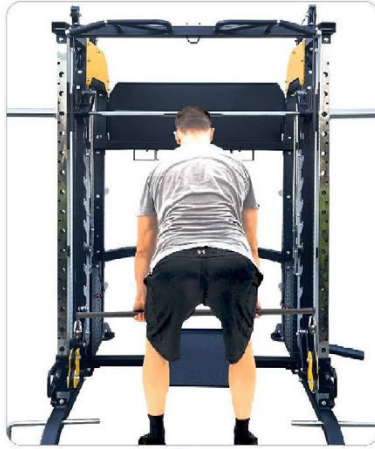

START

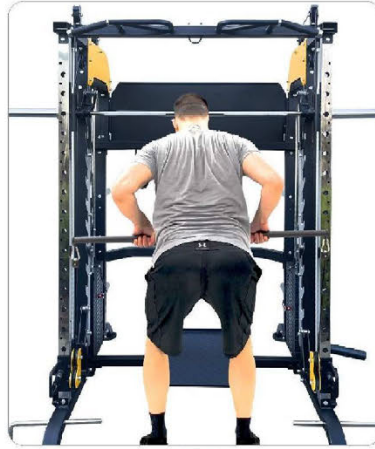

END

REVERSE GRIP BENT OVER ROWS

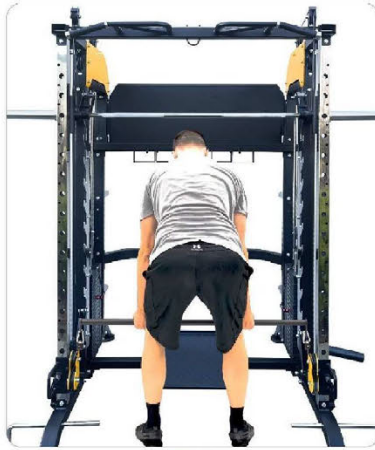

START

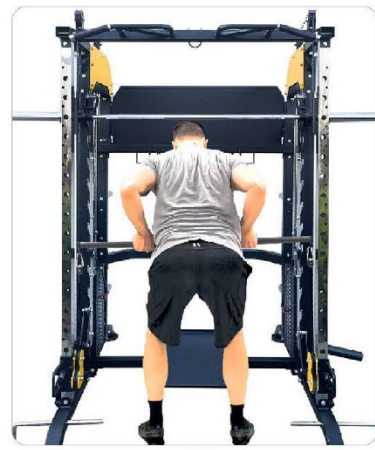

END

STANDING SQUAT

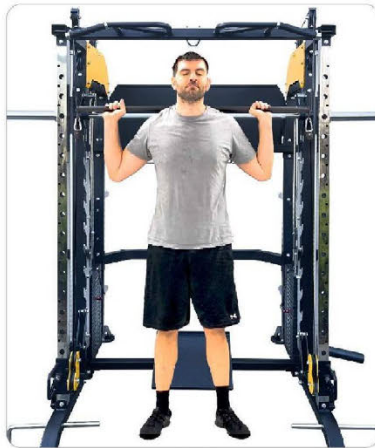

START

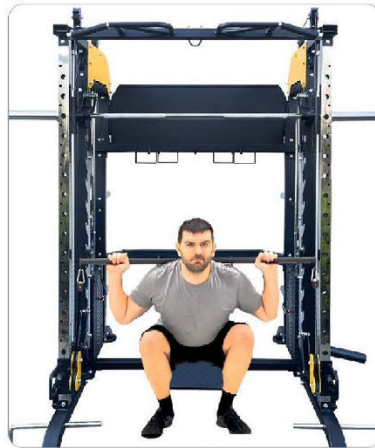

END

SHOULDER PRESS

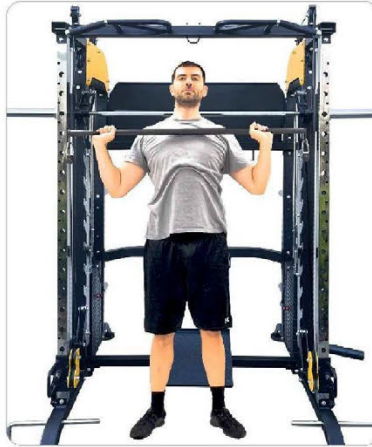

START

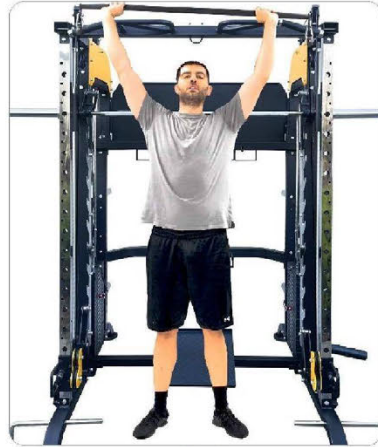

END

STANDING FRONT SQUATS

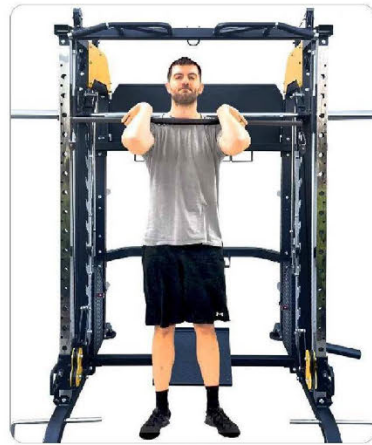

START

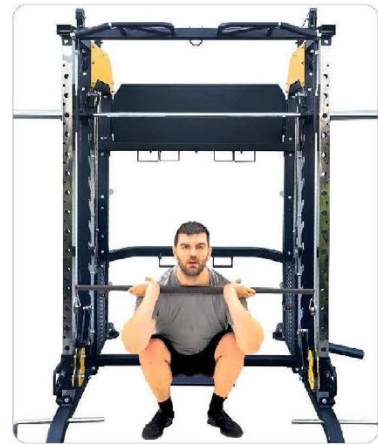

END

SEATED SHOULDER PRESS

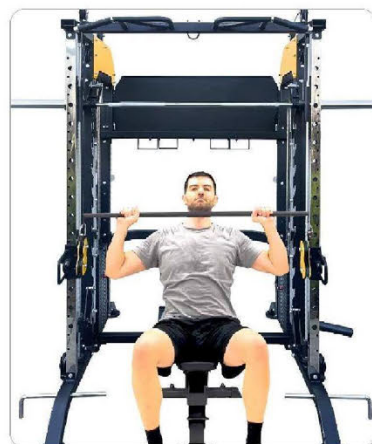

START

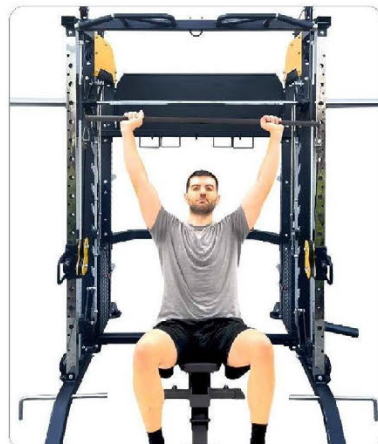

END

SHOULDER PRESS

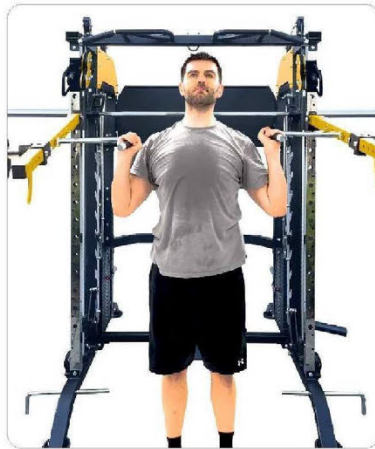

START

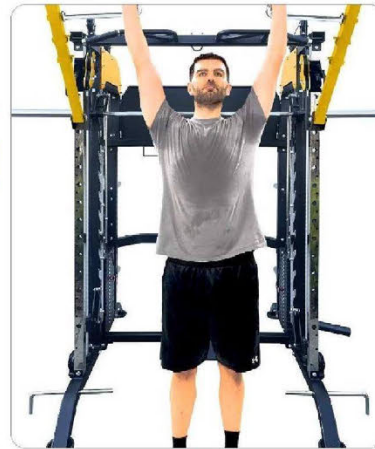

END

SEATED SHRUGS

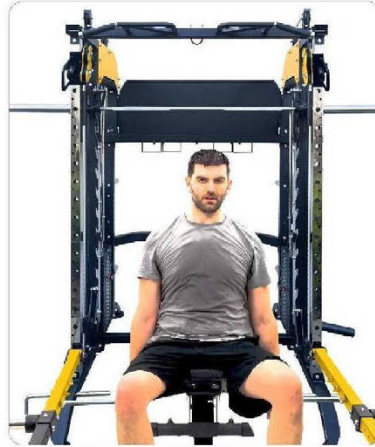

START

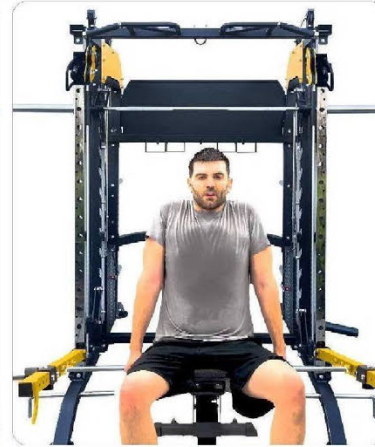

END

ISO LATERAL DECLINE BENCH

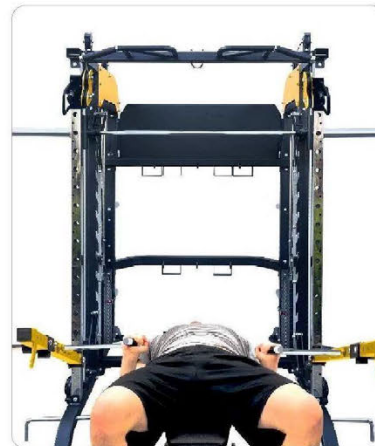

START

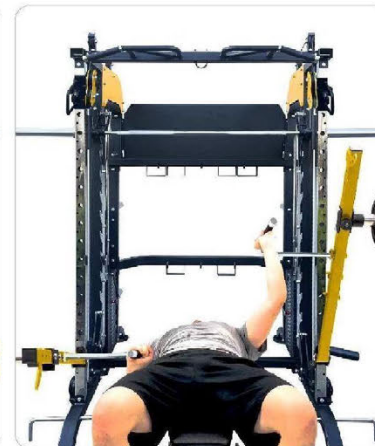

END

ISO LATERAL BENCH

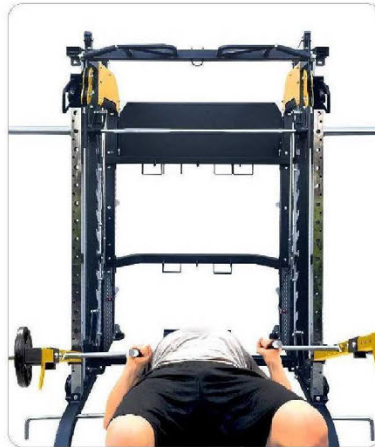

START

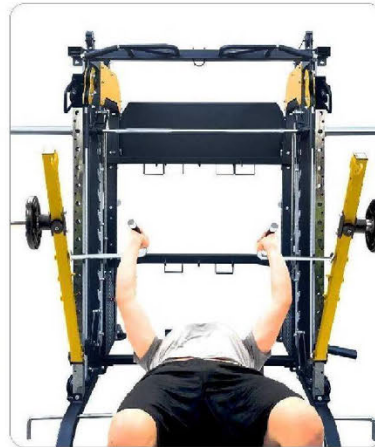

END

SEATED ABDOMINAL CRONCH

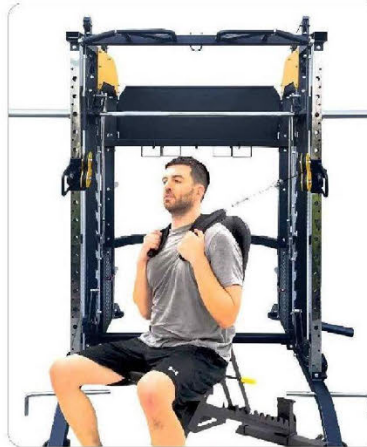

START

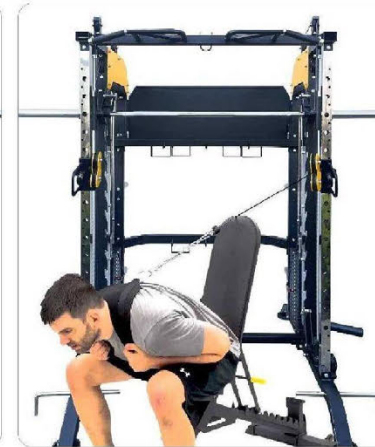

END

KNEELING ABDOMINAL CRONCH

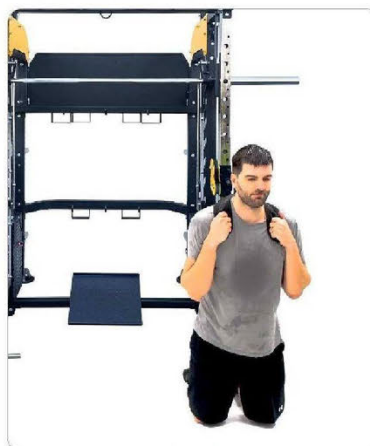

START



END

AB CRUNCH HARNESS
(Optional Attachment)

SEATED ABDOMINAL CRUNCH

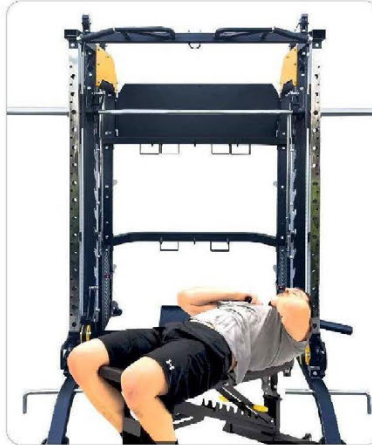

START

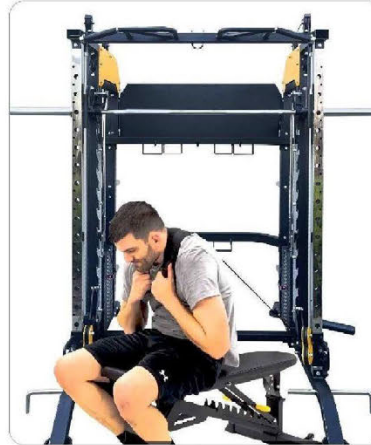

END

LANDMINE AND LAT BLASTER BAR (Optional Attachment)

LANDMINE ROWS

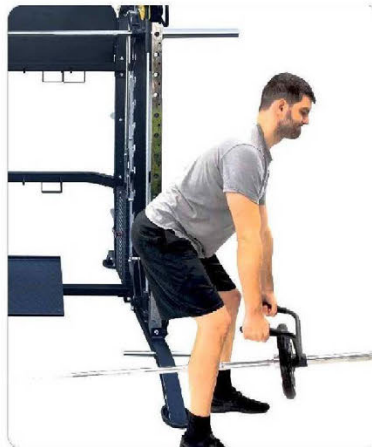

START

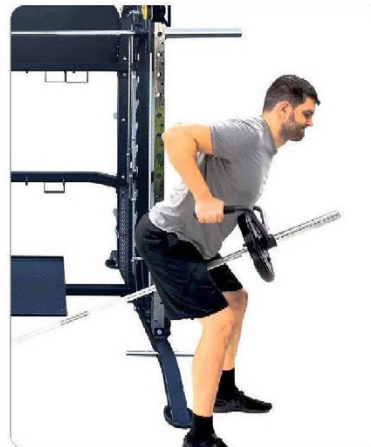

END

TRUNK ROTATIONS

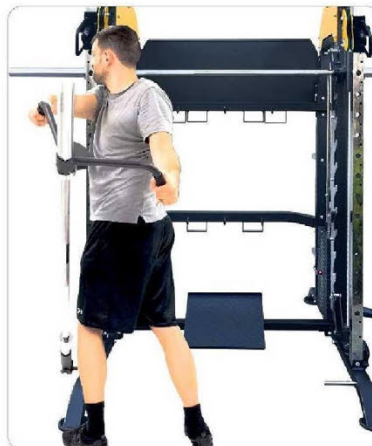

START

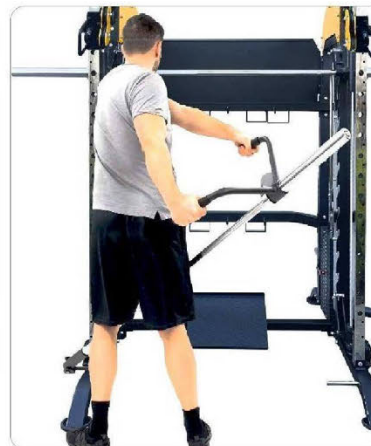

END

CLEAN AND SNATCH

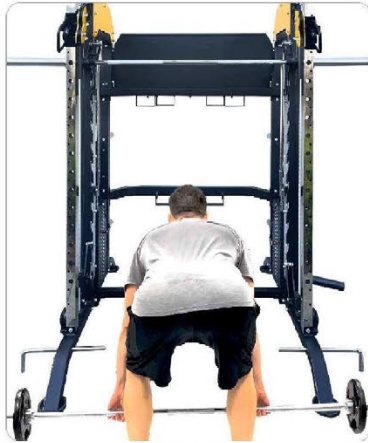

START

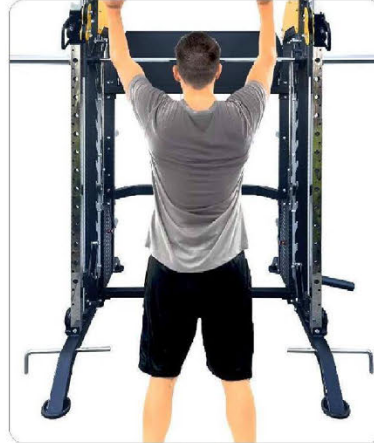

END

STIFF LEGGED DEADLIFT



START



END

REVERSE GRIP BENT OVER ROWS



START

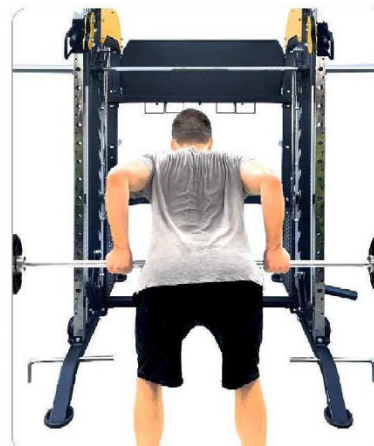

END

**CLEAN
AND PUSH
PRESS**



START

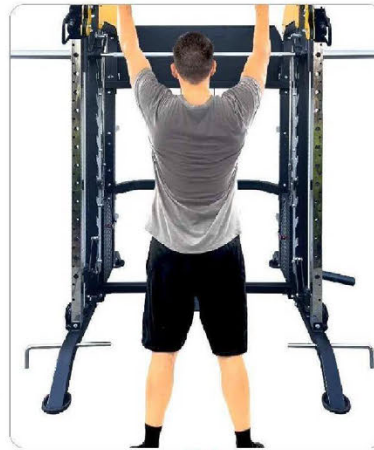

END

**SHOULDER
PRESS**

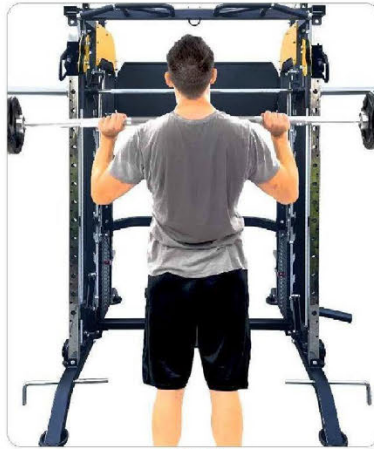

START

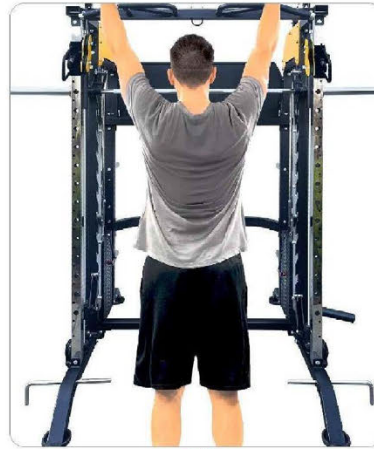

END

**BARBELL
SQUAT**

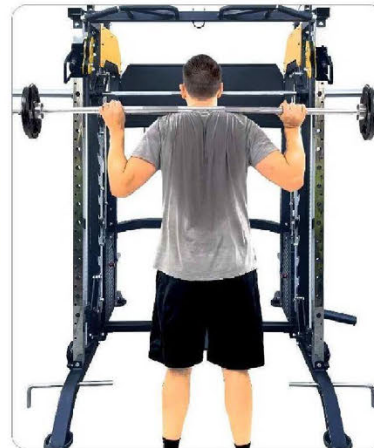

START



END

**BARBELL
BENCH
PRESS**



START



END

**INCLINE
CHEST**



START



END

**BARBELL
SHOULDER
PRESS**

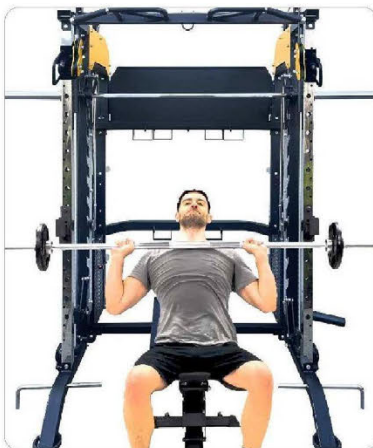

START

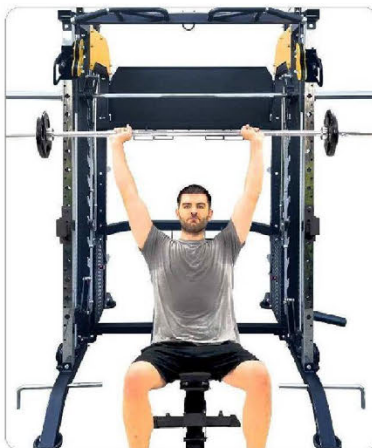

END

OLYMPIC BAR (Optional Attachment)

BARBELL LUNGES

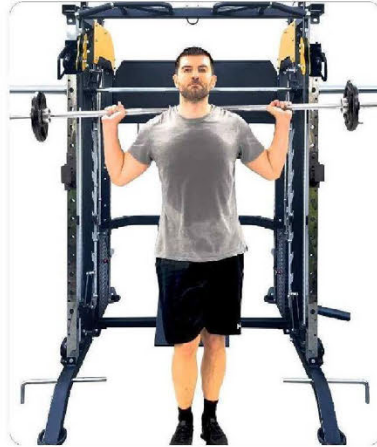

START



END