

# FRENCH FITNESS

FFS-DAP / FFB-DAP

**FRENCH FITNESS FFS SILVER / BLACK  
DUAL ADJUSTABLE PULLEY**

**OWNERS & ASSEMBLY MANUAL**



## FEATURES

- 11-gauge, 2.5" x 4.5" flat oval steel tube
- Nylon-coated cable meets U.S. military specifications
- Fiberglass-impregnated nylon pulleys feature sealed bearings
- Grips retained with aluminum collars, preventing them from slipping during use
- Hand grips are a durable urethane composite

## TECH SPECS

- Pulley Ratio: 2:1 ratio (Weight Stacks Feel like 110 lbs per side)
- Cable travel is double the weight stack travel
- Weight Stack: (2) 220 lb
- Weight: 670 lb
- Dimensions (L x W x H): 44" x 62" x 93" (1120 x 1570 x 2360 mm)

## WARRANTY

- **10 Years Parts, 1 Year Labor (Commercial)**

## **TABLE OF CONTENTS**

---

CLEAN GUIDE RODS .....	5
ASSEMBLY INSTRUCTION .....	6
WEIGHT STACK ASSEMBLY .....	10
TRAINING INSTRUCTION. PART 1 .....	14
TRAINING INSTRUCTION. PART 2 .....	17

## **BEFORE YOU BEGIN**

Thank you for selecting the DUAL ADJUSTABLE PULLEY. For your safety and benefit, read this manual carefully before using the machine. As a manufacturer, we are committed to provide you complete customer satisfaction. If you have any questions, or find there are missing or damaged parts, we guarantee you complete satisfaction through direct assistance from our factory.

## **IMPORTANT SAFETY NOTICE**

### **PRECAUTIONS**

This exercise machine is built for optimum safety. However, certain precautions apply whenever you operate a piece of exercise equipment. Be sure to read the entire manual before you assemble or operate your machine. In particular, note the following safety precautions:

1. **Keep children and pets away from the machine at all times. DO NOT leave children unattended in the same room with the machine.**
2. Only one person at a time should use the machine.
3. If the user experiences dizziness, nausea, chest pain, or any other abnormal symptoms, STOP the workout at once. CONSULT A PHYSICIAN IMMEDIATELY.
4. Position the machine on a clear, leveled surface. DO NOT use the machine near water or outdoors.
5. Keep hands away from all moving parts.
6. Always wear appropriate workout clothing when exercising. DO NOT wear robes or other clothing that could become caught in the machine. Running or aerobic shoes are also required when using the machine.
7. Use the machine only for its intended use as described in this manual. DO NOT use attachments not recommended by the manufacturer.
8. Do not place any sharp object around the machine.
9. Disabled person should not use the machine without a qualified person or physician in attendance.
10. Before using the machine to exercise, always do stretching exercises to properly warm up.
11. Never operate the machine if the machine is not functioning properly.
12. A spotter is recommended during exercise.

## CLEAN GUIDE RODS

Step must be completed prior to installing. Failure to do so can leave residue from packaging and other sources stuck in the bushings.

Guide rods need to make sure they are cleaned prior to installation otherwise this will cause the top plate to get stuck. It causes buildup in the bushings of the top plates. They just need to be cleaned out as well as the guide rods.

Use Silicon Spray and fiber to remove any excess residue. These can be found around the house or at a nearby hardware store, pics below. Use silicon Spray and steel wool.

We use "B'laster 16-SL Industrial Strength Silicone Lubricant" and Steel Wool, Grade #0000 Super Fine Grade.



**SAVE THESE INSTRUCTIONS.**

## **ASSEMBLY INSTRUCTION**

**Tools Required Assembling the Machine: Two Adjustable Wrenches, two Allen Wrenches, and one Philips Screwdriver. NOTE: It is strongly recommended this machine to be assembled by two or more people to avoid possible injury.**

### **STEP 1 (See Diagram 1)**

A.) Slide the Cable Adjustment Assembly(#3) onto the Front Vertical Frame(#2). Insert the Lock Knob(#5) into the Cable Adjustment Assembly(#3).

B.) Attach the Front Vertical Frame(#2) to the Main Frame(#1). Secure it with Bolt M10X75 (#6),  $\varnothing$  10 Washer(#8) and M10 Aircraft Nut(#9).

C.) Attach the Pulley Bracket(#4) to the Cable Adjustment Assembly(#3). Secure it with Bolt M10X90 (#7),  $\varnothing$  10 Washer(#8) and M10 Aircraft Nut(#9).

### **DIAGRAM 1**

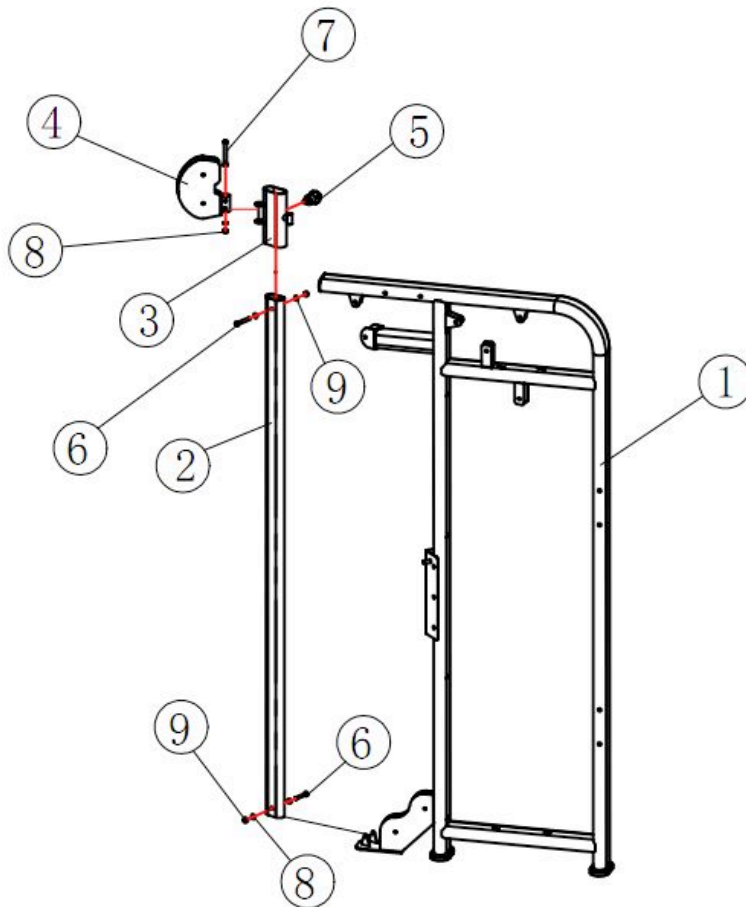

## STEP 2 (See Diagram 2)

A.) Attach the Cross Support(#11)to the Main Frame(#1).Secure it with Bolt M10x120(#15), $\varnothing$  10 Washer(#8),M10 Aircraft Nut(#9).

B.) Attach the Pull Down Assembly(#10) to the Main Frame(#1).Secure it with Bolt M10x120(#15), $\varnothing$  10 Washer(#8),M10 Aircraft Nut(#9).

C.) Attach the Accessories Hanging Plate(#12) to the Cross Support(#11). Secure it with Bolt M10x120(#15), $\varnothing$  10 Washer(#8),M10 Aircraft Nut(#9).

## DIAGRAM 2

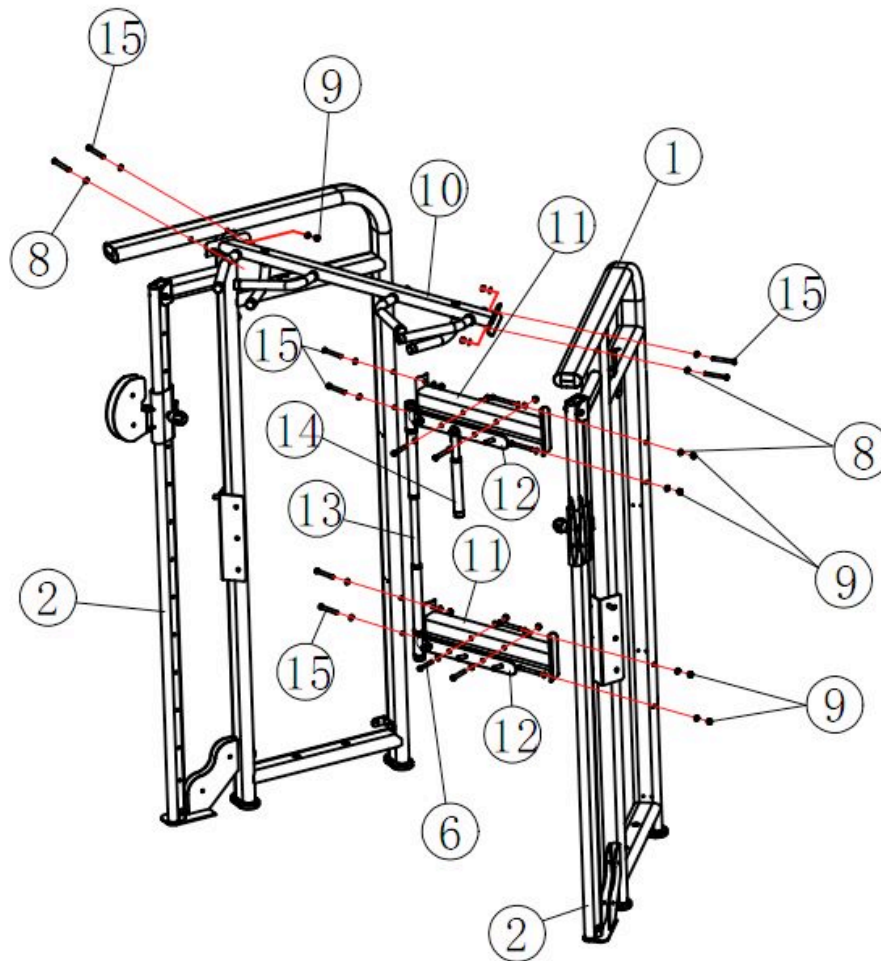

### STEP 3 (See Diagram 3)

A) Insert the Guide Rod (#17) into the holes of Main Frame (#1). Slide the Rubber Bumper onto the Guide Rod (#17).

B) Sloping the top of Guide Rod (#17). Then slide the weight stack (#20) onto the Guide Rod (#17). Attach the Guide Rod (#17) onto the Main Frame (#1).

Insert the Selector Rod (#19) through the center hole of weight stack.

C) Use the Magnetic Pin (#21) to select the number of plates

### DIAGRAM 3

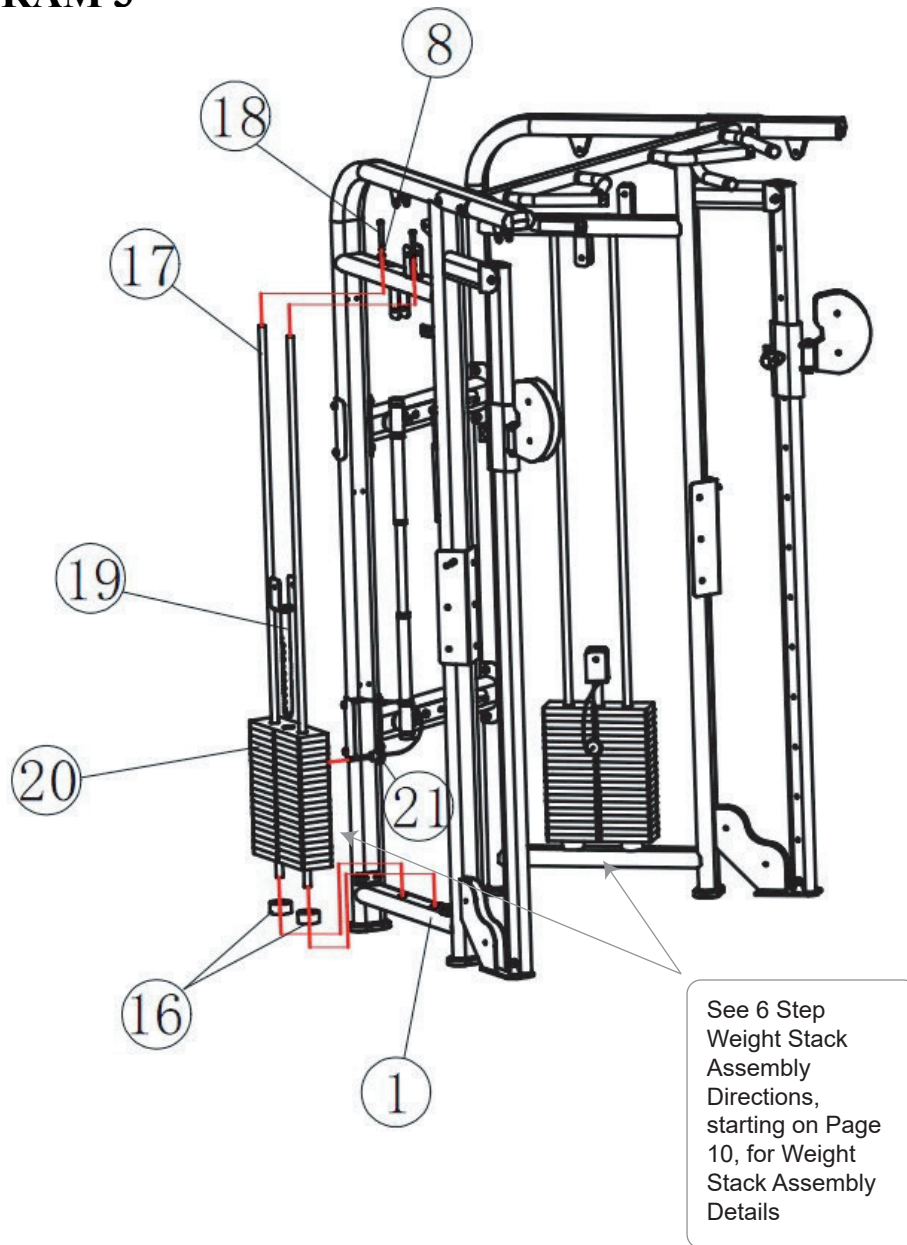



**STEP 4** (See Diagram 4)

- A) Assemble the Cable (#23) based on the below cableloop diagram. Secure it with Bolt M6X15 (#25) after finishing cable assembly.
- B) Attach the Handle (#22) to the Cable (#23) with C-clip (#21).
- C) Tighten all the bolts and nuts hard.

**DIAGRAM 4**

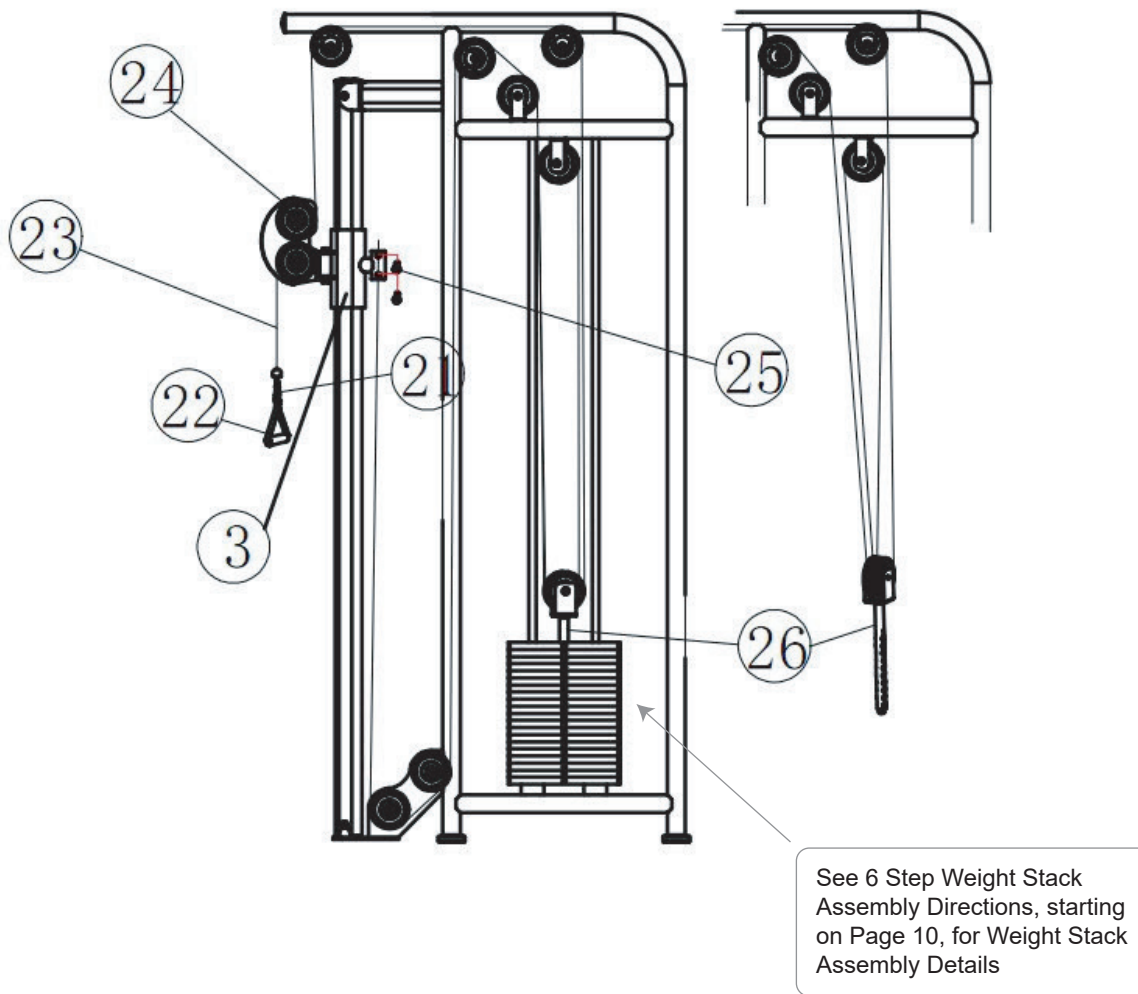

## **WEIGHT STACK ASSEMBLY**

### **STEP 1. RUBBER BUMPERS**



### **STEP 2. GUIDE RODS – TILT OUT**



### STEP 3. WEIGHT PLATES



### STEP 4. TOP PLATE/SELECTOR ROD – REMOVE FROM CABLE FOR NOW + INSTALL THE TOP PLATE

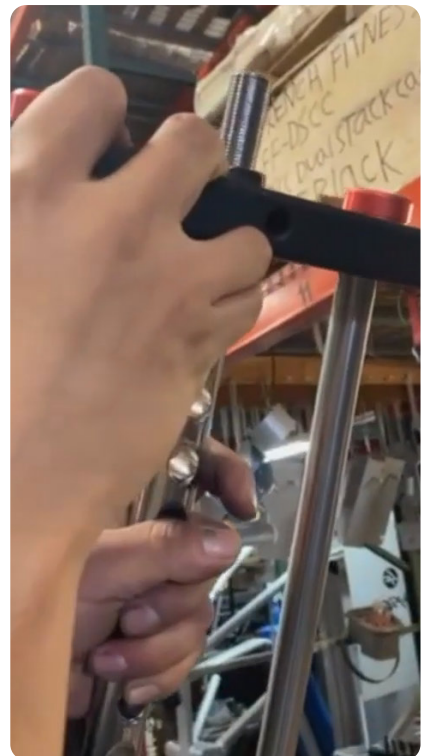

**STEP 5. TILT IN GUIDE RODS –  
RAISE THEM IN ORDER TO BOLT THEM IN**



**STEP 6. INSTALL THE WEIGHT SELECTOR PIN AND REATTACH CABLE TO THE TOP PLATE AND THEN STORE WEIGHT ADAPTERS ON THE CHROME BRACKET AT THE TOP SO THAT THE CABLE CAN BE TIGHTENED AND ADJUSTED**



## ASSEMBLY INSTRUCTIONS



- 1) Attach the shrouds using included screws to the black brackets
- 2) Once attached, apply circular "FF" stickers onto the shroud, on the side that faces away from the weight stacks, with the bottom of the FF circle at the height of the top weight stack plate.

# Training Instruction. Part 1

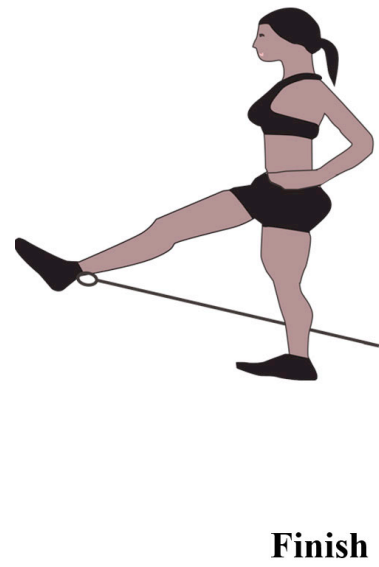
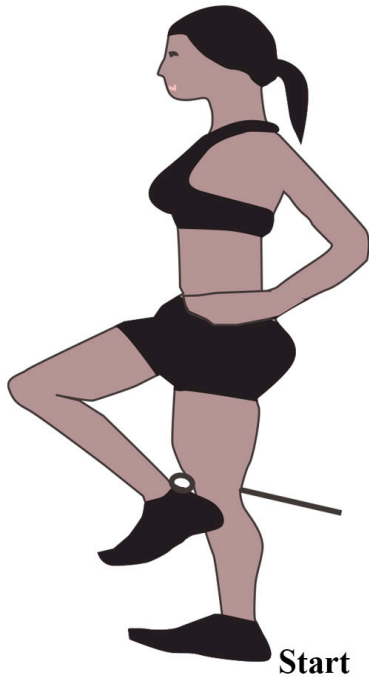
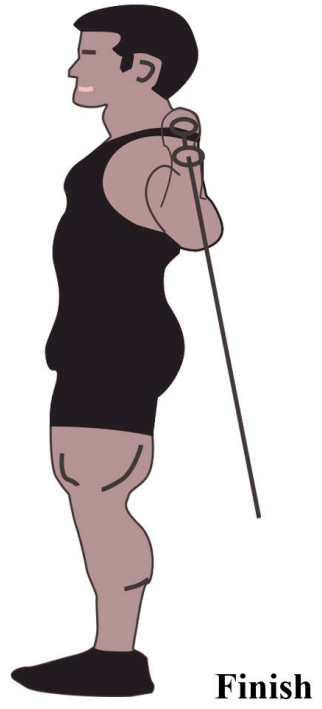

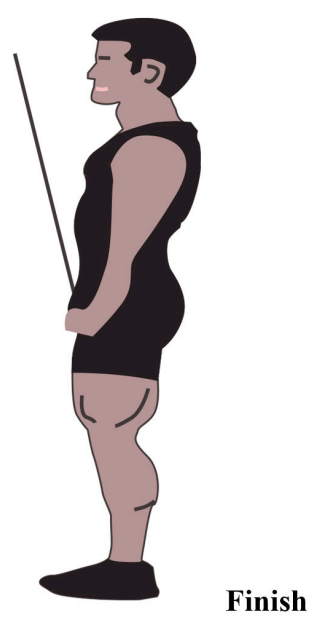
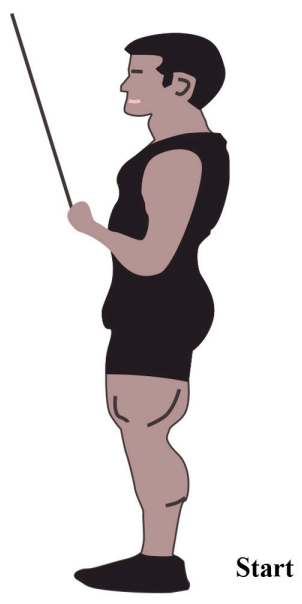
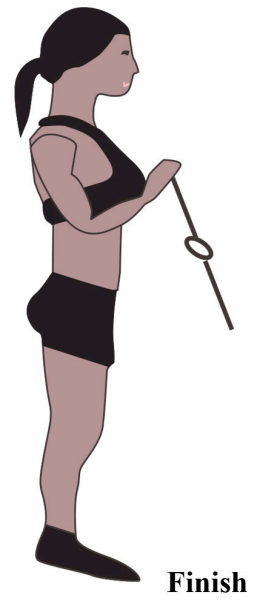
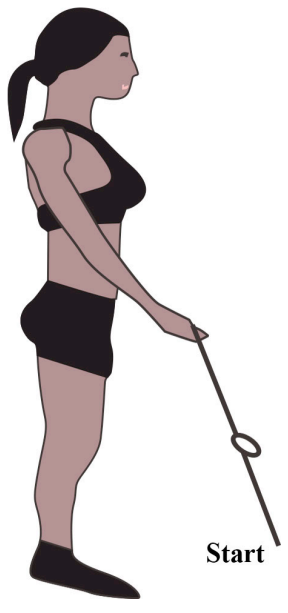





**Start**



**Finish**



**Start**



**Finish**

# FFS-DAP & FFB-DAP

FRENCH FITNESS FFS SILVER & FFB BLACK DUAL ADJUSTABLE PULLEY

# FRENCH FITNESS



## CONDITIONING

Strengthens your heart and lungs while increasing your metabolic rate.



## POWER

Increases speed and agility by activating fast twitch muscle fibers.



## STRENGTH

Increase muscle, tendon and ligament strength; bone density; metabolic rate while improving heart and body composition.



## FLEXIBILITY

Increase range of motion, flexibility and reduce the risk of injury.



## WARNING

Consult your physician before beginning this or any exercise program. Keep out of reach of children.



# FFS-DAP & FFB-DAP

FRENCH FITNESS FFS SILVER & FFB BLACK DUAL ADJUSTABLE PULLEY

# FRENCH FITNESS

Alternating chest press

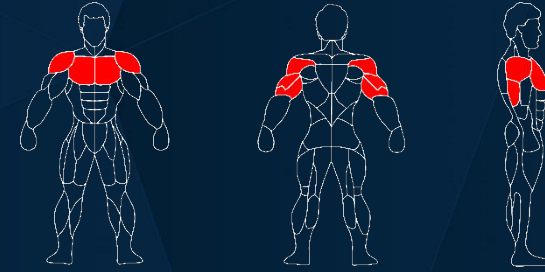

# FFS-DAP & FFB-DAP

FRENCH FITNESS FFS SILVER & FFB BLACK DUAL ADJUSTABLE PULLEY

# FRENCH FITNESS

Kneeling pulldown

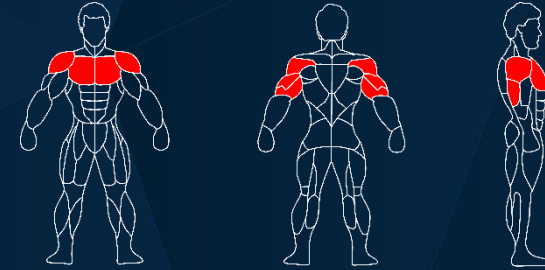

# FFS-DAP & FFB-DAP

FRENCH FITNESS FFS SILVER & FFB BLACK DUAL ADJUSTABLE PULLEY

# FRENCH FITNESS

Reverse cable x-over

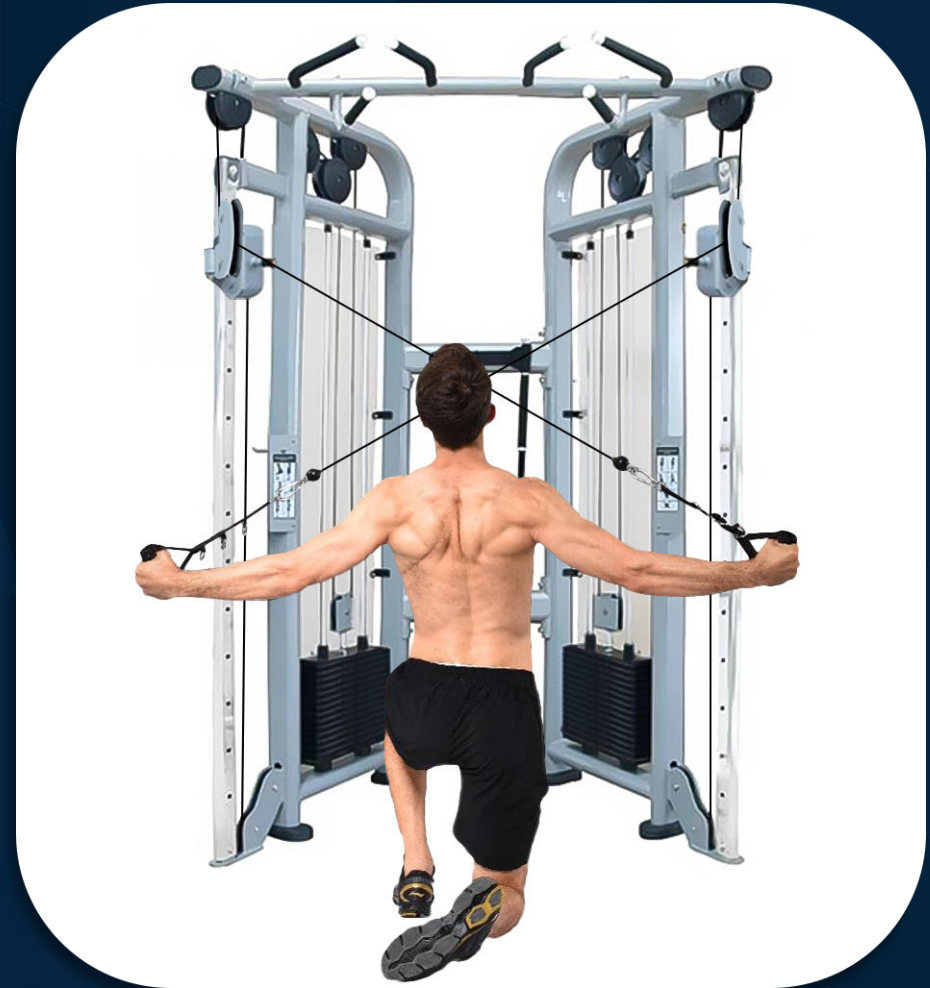
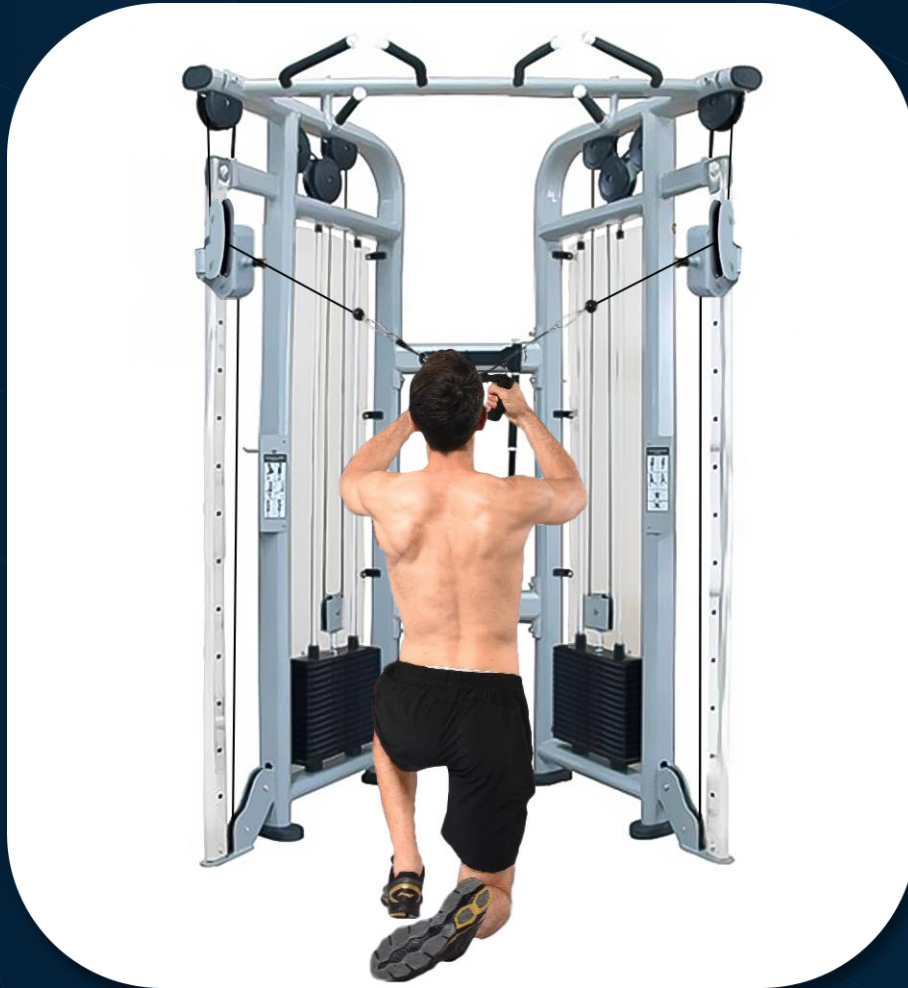
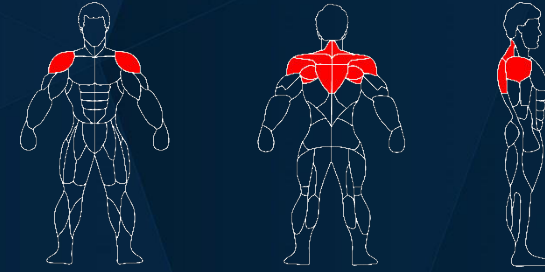

# FFS-DAP & FFB-DAP

FRENCH FITNESS FFS SILVER & FFB BLACK DUAL ADJUSTABLE PULLEY

# FRENCH FITNESS

Reverse fly

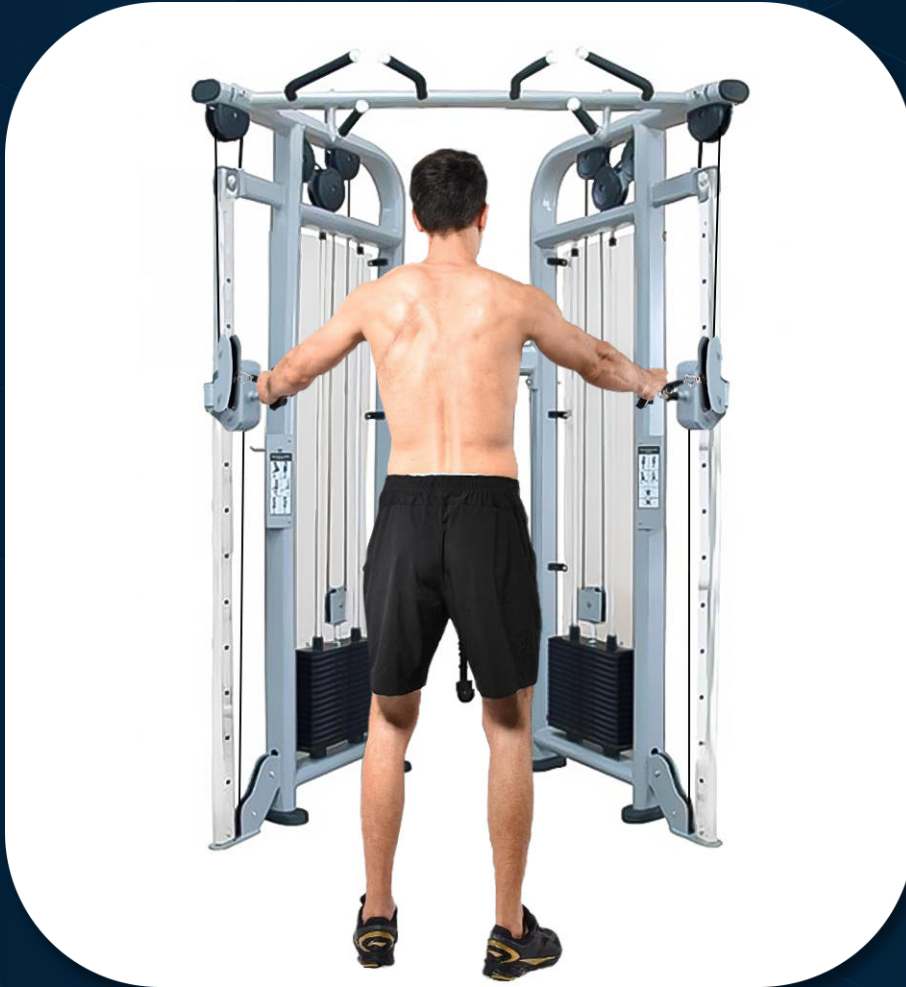
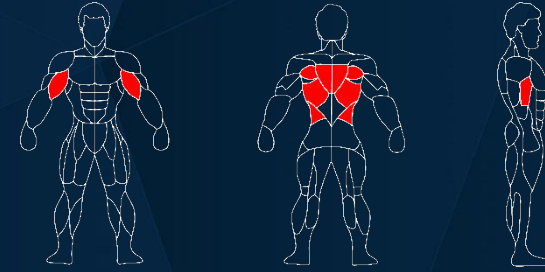

# FFS-DAP & FFB-DAP

FRENCH FITNESS FFS SILVER & FFB BLACK DUAL ADJUSTABLE PULLEY

# FRENCH FITNESS

Floor seated row

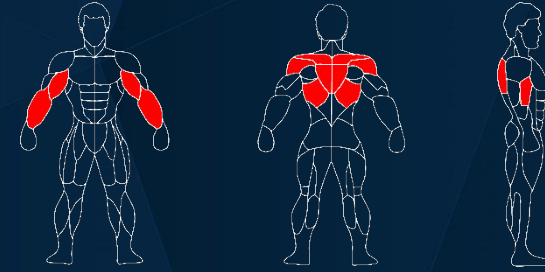

# FFS-DAP & FFB-DAP

FRENCH FITNESS FFS SILVER & FFB BLACK DUAL ADJUSTABLE PULLEY

# FRENCH FITNESS

Side bend

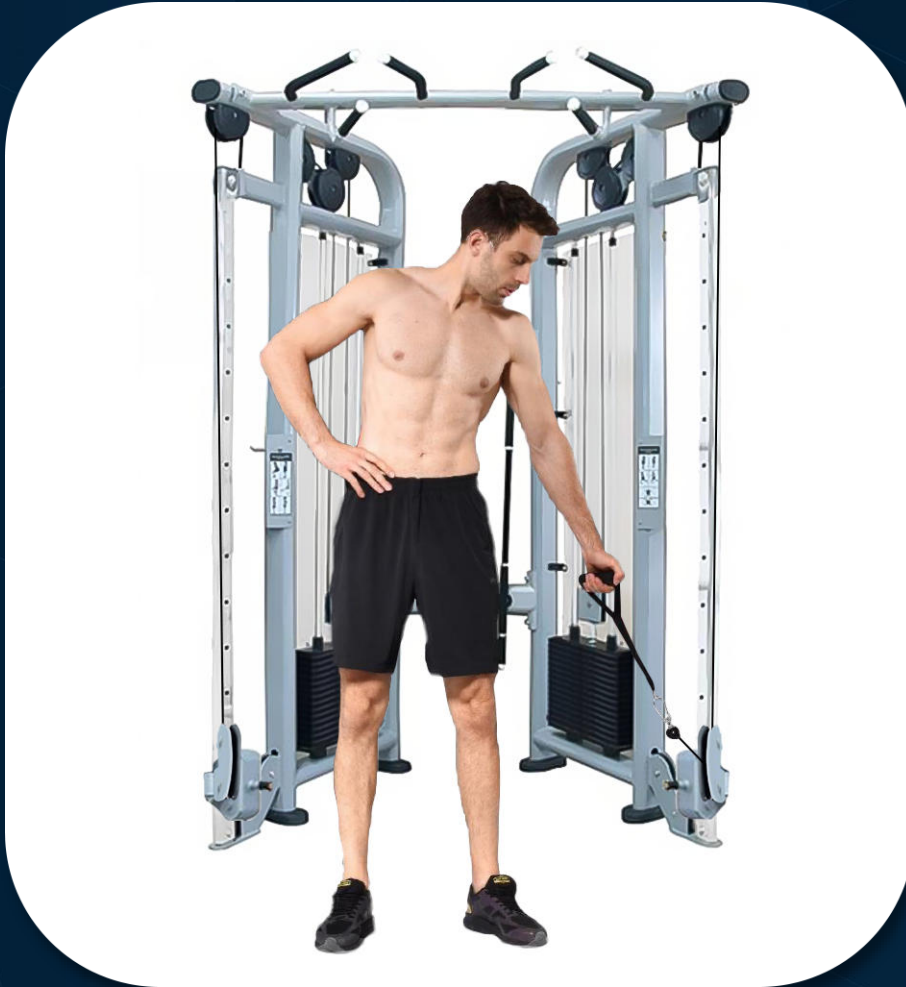
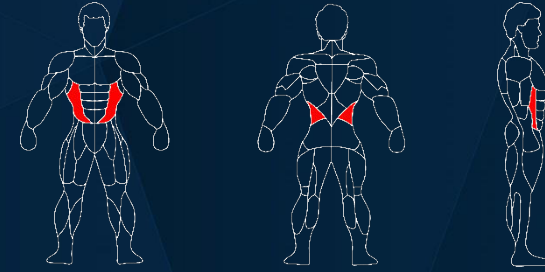



# FFS-DAP & FFB-DAP

FRENCH FITNESS FFS SILVER & FFB BLACK DUAL ADJUSTABLE PULLEY

# FRENCH FITNESS

Rotational row single leg

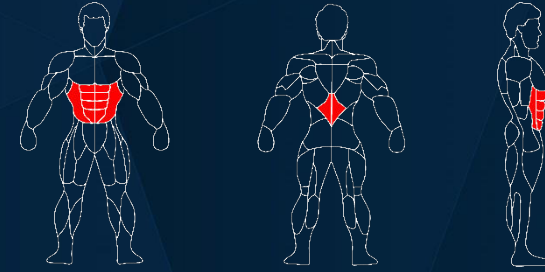

# FFS-DAP & FFB-DAP

FRENCH FITNESS FFS SILVER & FFB BLACK DUAL ADJUSTABLE PULLEY

# FRENCH FITNESS

Woodchopper

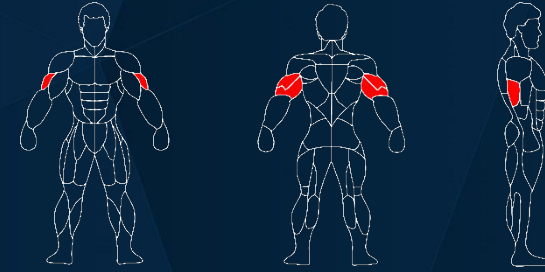

# FFS-DAP & FFB-DAP

FRENCH FITNESS FFS SILVER & FFB BLACK DUAL ADJUSTABLE PULLEY

# FRENCH FITNESS

Anti-rotation

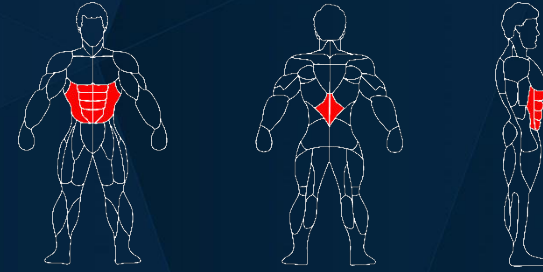

# FFS-DAP & FFB-DAP

FRENCH FITNESS FFS SILVER & FFB BLACK DUAL ADJUSTABLE PULLEY

# FRENCH FITNESS

X-over latraise

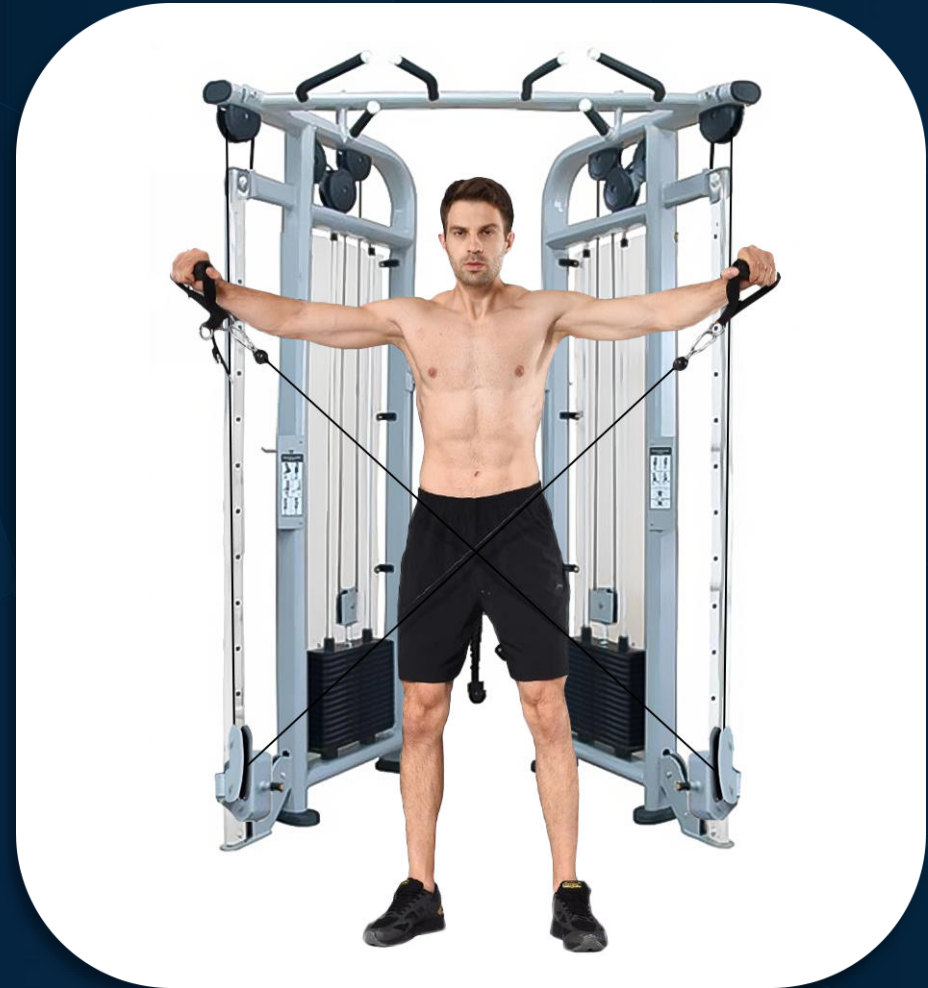
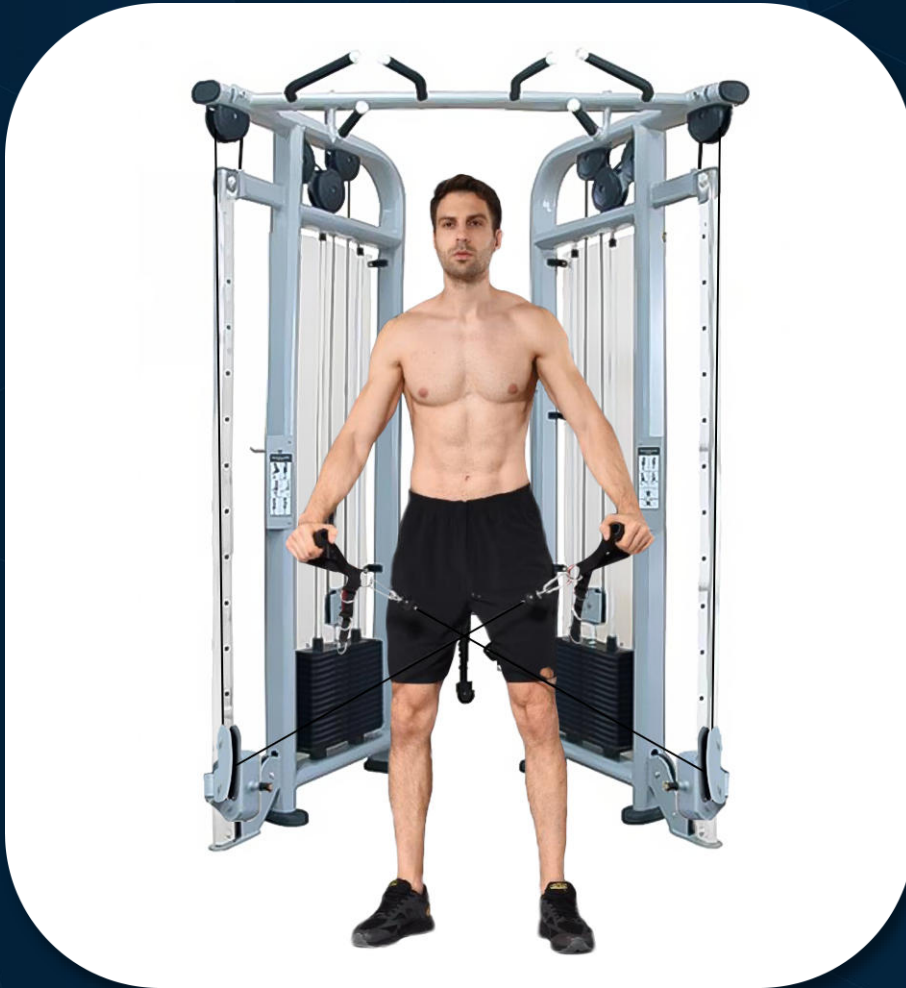
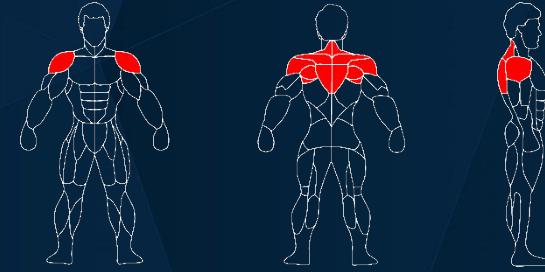

# FFS-DAP & FFB-DAP

FRENCH FITNESS FFS SILVER & FFB BLACK DUAL ADJUSTABLE PULLEY

# FRENCH FITNESS

Lateral raise

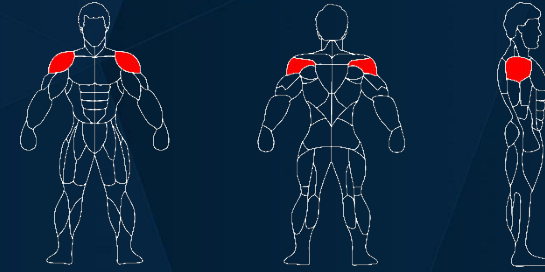

# FFS-DAP & FFB-DAP

FRENCH FITNESS FFS SILVER & FFB BLACK DUAL ADJUSTABLE PULLEY

# FRENCH FITNESS

External rotation

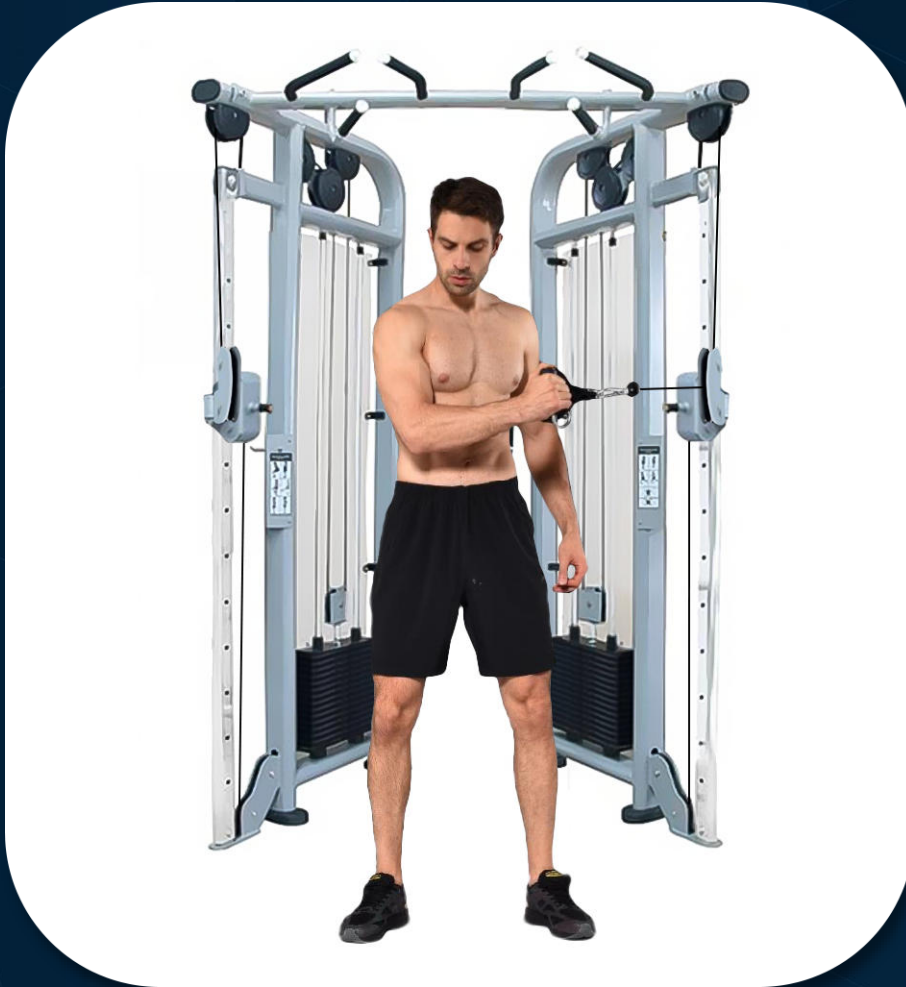
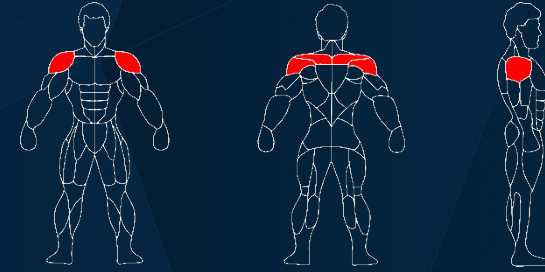

# FFS-DAP & FFB-DAP

FRENCH FITNESS FFS SILVER & FFB BLACK DUAL ADJUSTABLE PULLEY

# FRENCH FITNESS

Shoulder press

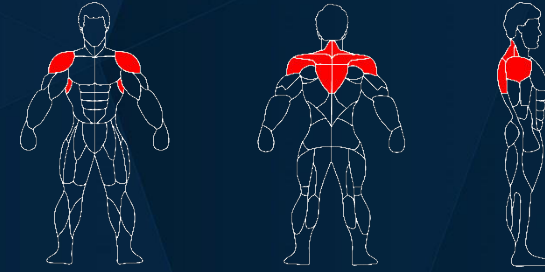

# FFS-DAP & FFB-DAP

FRENCH FITNESS FFS SILVER & FFB BLACK DUAL ADJUSTABLE PULLEY

# FRENCH FITNESS

Hip abduction

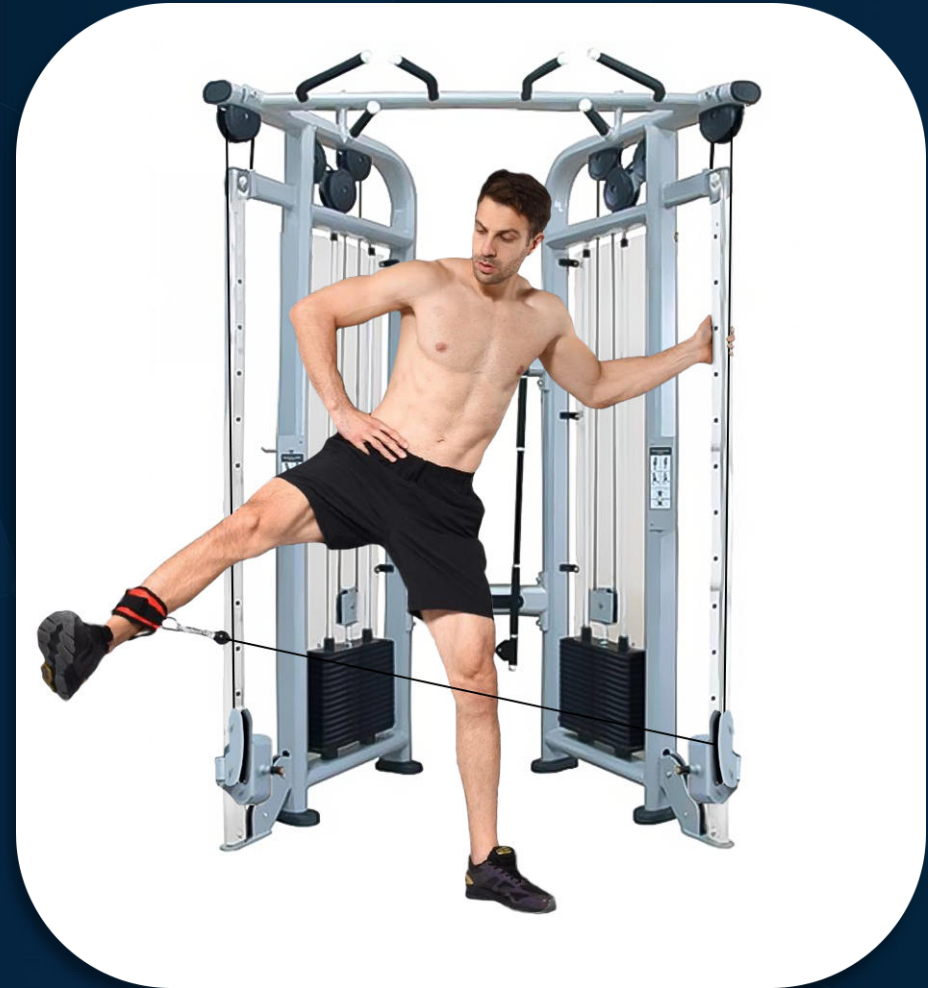
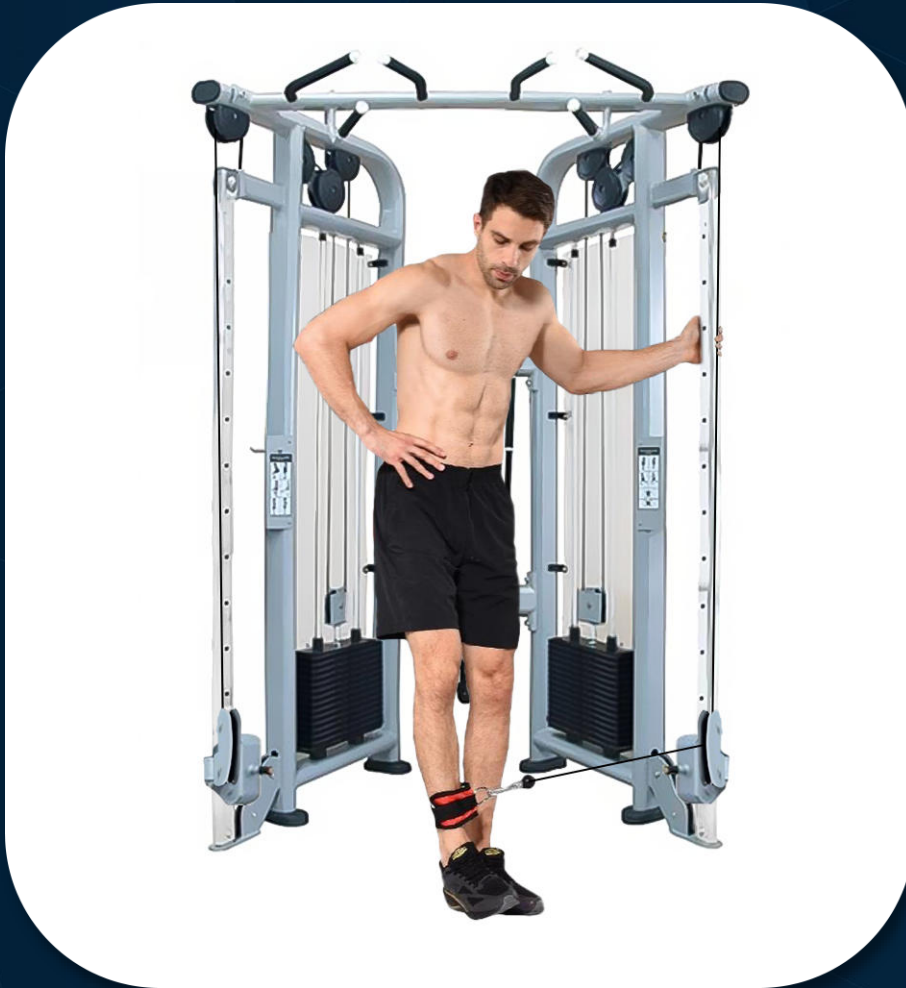
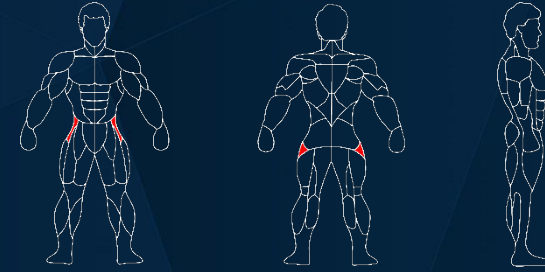



# FFS-DAP & FFB-DAP

FRENCH FITNESS FFS SILVER & FFB BLACK DUAL ADJUSTABLE PULLEY

# FRENCH FITNESS

Leg curl

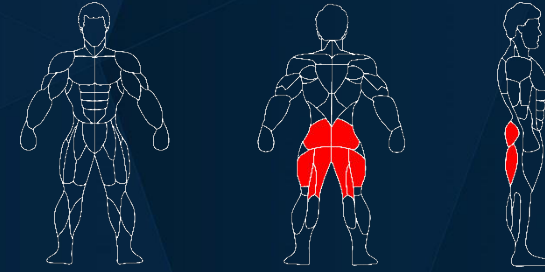

# FFS-DAP & FFB-DAP

FRENCH FITNESS FFS SILVER & FFB BLACK DUAL ADJUSTABLE PULLEY

# FRENCH FITNESS

Hip adduction

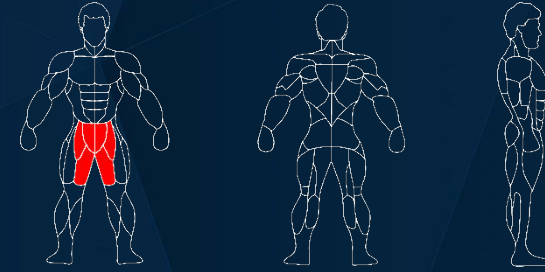

# FFS-DAP & FFB-DAP

FRENCH FITNESS FFS SILVER & FFB BLACK DUAL ADJUSTABLE PULLEY

# FRENCH FITNESS

Lunge

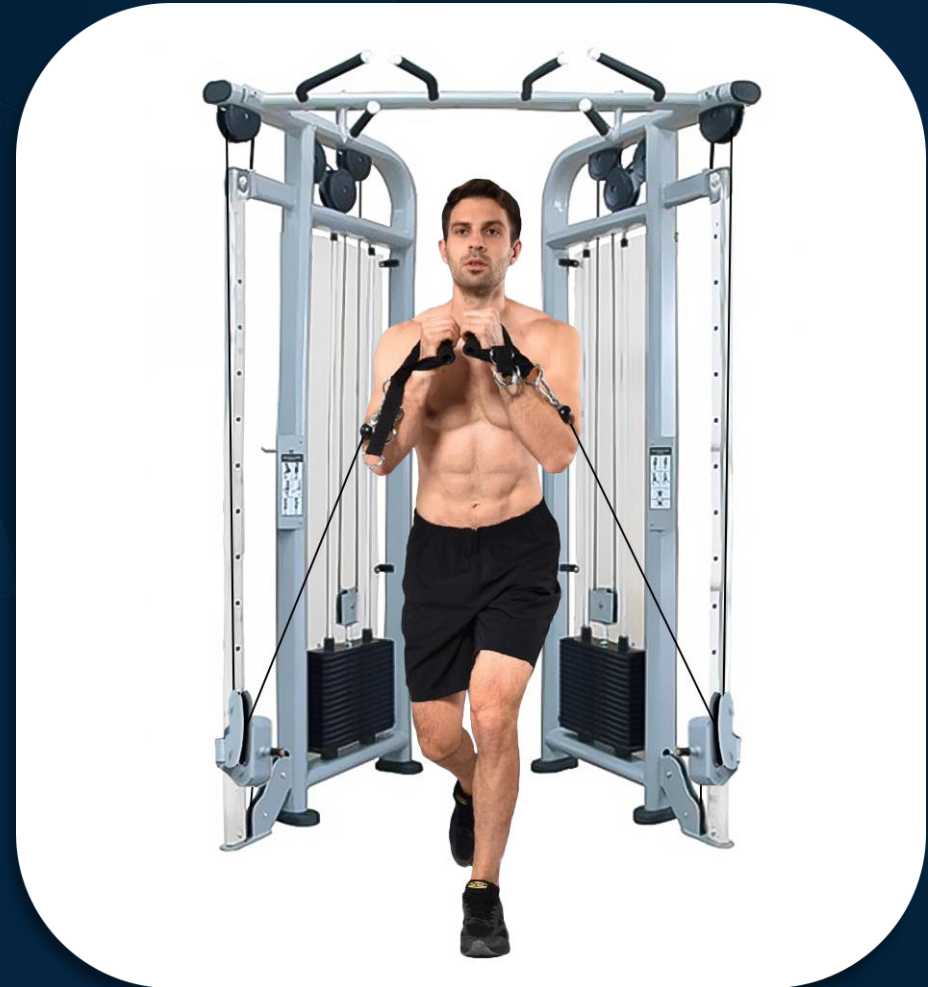
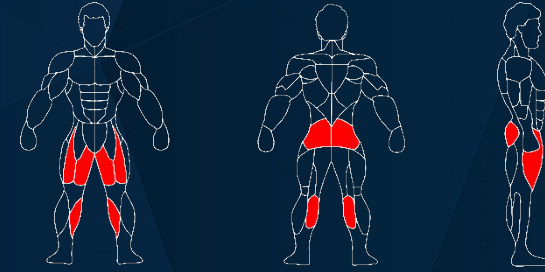

# FFS-DAP & FFB-DAP

FRENCH FITNESS FFS SILVER & FFB BLACK DUAL ADJUSTABLE PULLEY

# FRENCH FITNESS

Hip flexion

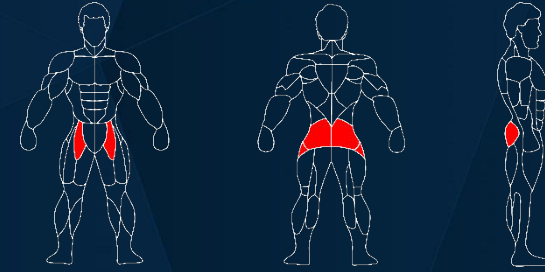

# FFS-DAP & FFB-DAP

FRENCH FITNESS FFS SILVER & FFB BLACK DUAL ADJUSTABLE PULLEY

# FRENCH FITNESS

Kneeling superman

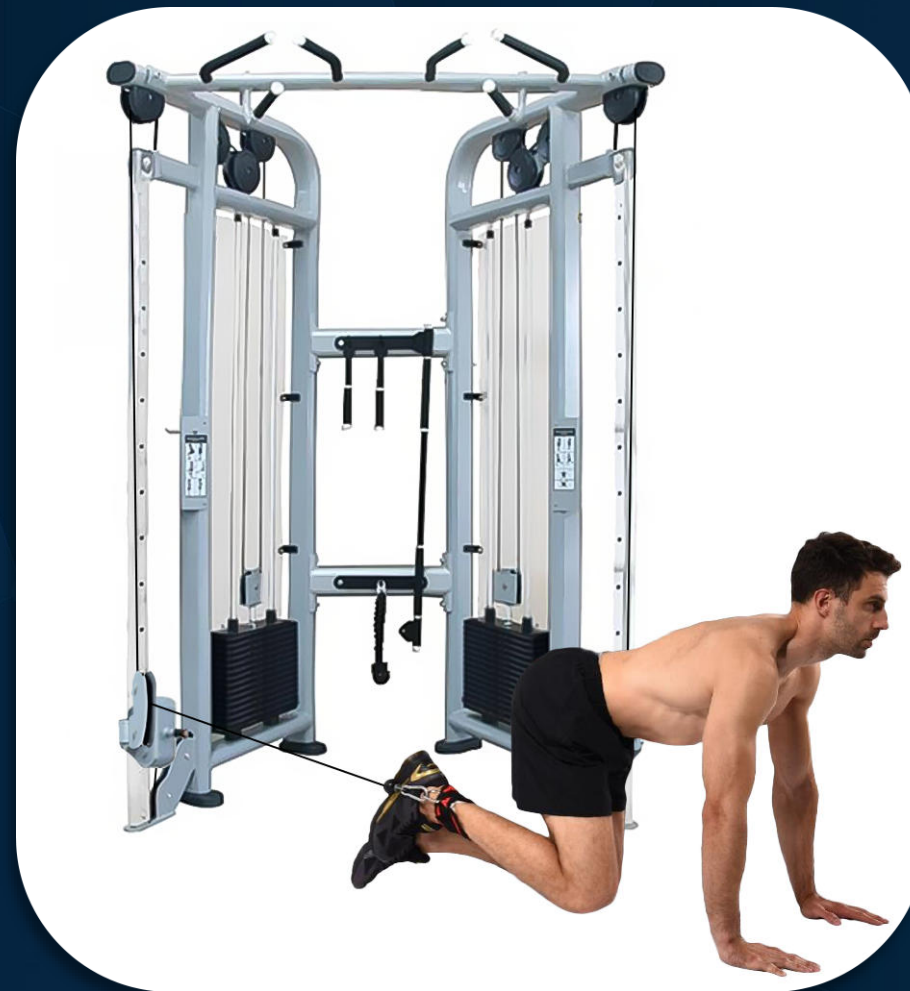
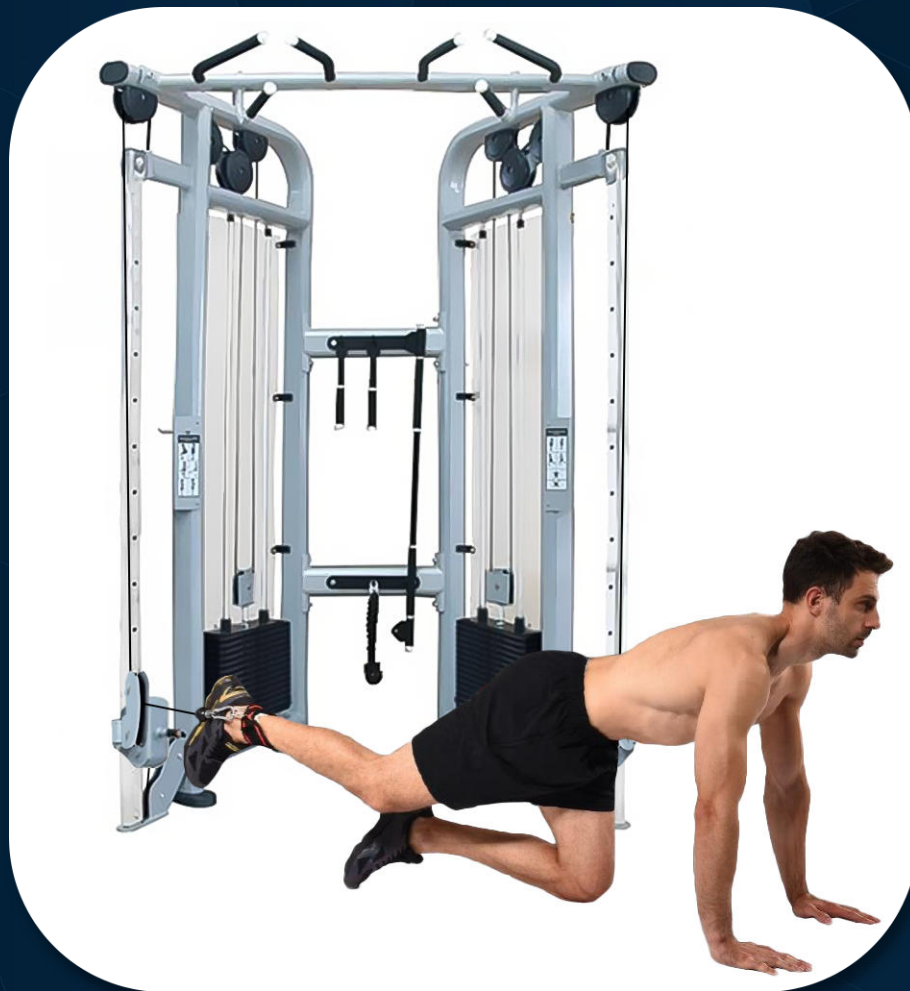
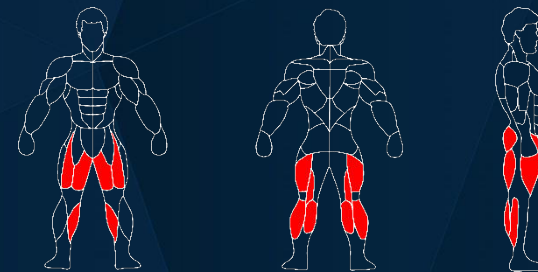

# FFS-DAP & FFB-DAP

FRENCH FITNESS FFS SILVER & FFB BLACK DUAL ADJUSTABLE PULLEY

# FRENCH FITNESS

Pull-up

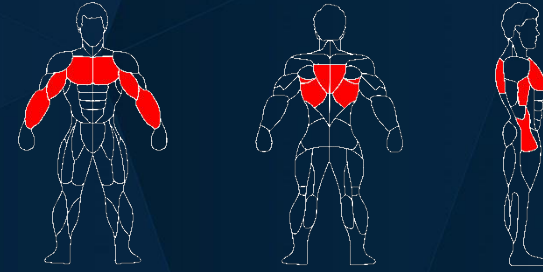

# FFS-DAP & FFB-DAP

FRENCH FITNESS FFS SILVER & FFB BLACK DUAL ADJUSTABLE PULLEY

# FRENCH FITNESS

Chest press with bar

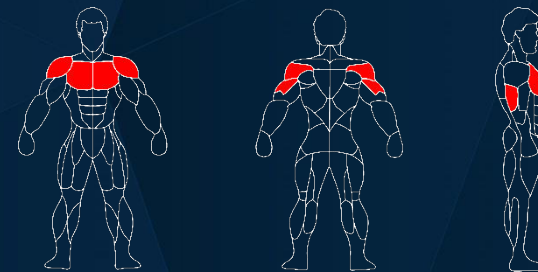

# FFS-DAP & FFB-DAP

FRENCH FITNESS FFS SILVER & FFB BLACK DUAL ADJUSTABLE PULLEY

# FRENCH FITNESS

Pullover

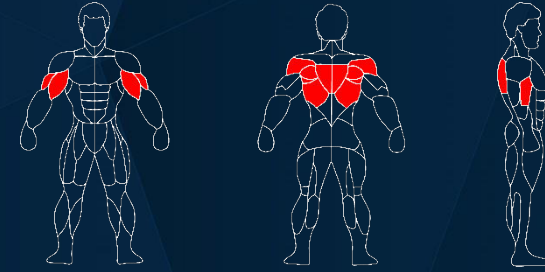



# FFS-DAP & FFB-DAP

FRENCH FITNESS FFS SILVER & FFB BLACK DUAL ADJUSTABLE PULLEY

# FRENCH FITNESS

Stand type pull rod bending

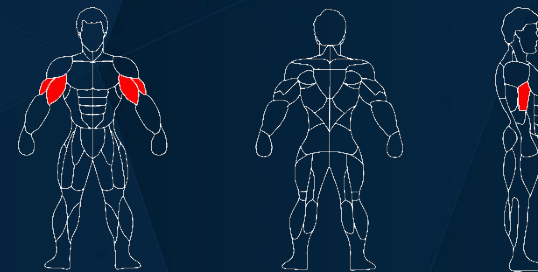

# FFS-DAP & FFB-DAP

FRENCH FITNESS FFS SILVER & FFB BLACK DUAL ADJUSTABLE PULLEY

# FRENCH FITNESS

Curved arm dropdown

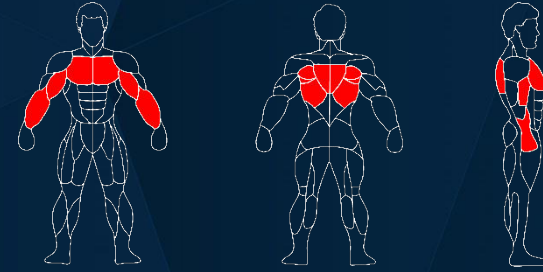



**FRENCH FITNESS**

**THE LEADER OF PROFESSIONAL STRENGTH FITNESS EQUIPMENTS**

**French Fitness**

Local / International: +1-925-215-2927

Toll Free: 1-844-348-7253 (1-844-FIT-SALE)

E-mail: [info@frenchfitness.com](mailto:info@frenchfitness.com)

Website: [www.frenchfitness.com](http://www.frenchfitness.com)