

FRENCH FITNESS

FFP-DCC / FFA-DCC

FRENCH FITNESS ASPEN / PHOENIX
DUAL CABLE CROSS - SILVER / BLACK

ASSEMBLY MANUAL



OR



CAUTION!

Read all precautions and instructions in this manual before using this equipment.

20240416-V1.0

FEATURES

- **Versatility:** Allows for a wide range of exercises, targeting various muscle groups, which makes it suitable for full-body workouts.
- **Isolation and Integration:** You can perform both isolation exercises (targeting a specific muscle group) and integration exercises (engaging multiple muscle groups).
- **Customizable Resistance:** The adjustable weight stacks make it easy to modify the resistance according to your fitness level and goals.
- **Balanced Muscle Development:** The independent movement of the cable handles helps prevent muscle imbalances by ensuring both sides of your body work equally.
- **Range of Motion:** The pulley system provides a smooth and controlled range of motion, reducing the risk of joint strain and injury.
- **Functional Training:** Allows you to mimic natural movements, making it suitable for functional training that can translate to everyday activities.
- **Variety:** With the ability to change handle heights and angles, you can switch up your exercises easily.
- **Beginner-Friendly:** Guided movements offer valuable assistance for beginners learning proper exercise form.
- **Stability and Safety:** Shrouded weight stacks, seamlessly blending safety with a touch of elegant aesthetics for a truly captivating fitness experience.
- **Inclusive Design:** Wheelchair accessible, ensuring inclusivity for a diverse range of users.
- "Includes Tablet Holder. *Tablet sold separately"

This innovative fitness equipment bridges the gap between traditional strength training and functional fitness, offering an all-encompassing solution for anyone looking to enhance their physical health and performance.

TECH SPECS

- Cable Ratio: 2:1
- Vertical Adjustments: 13
- Horizontal Adjustments: 5
- Weight Stacks: 200 lbs per Side (400 lbs total)
- Depth: 51.7" (With arms folded), 57.1" (with arms fully extended)
- Width: 56.8" at feet (With arms folded), 115.8" (with arms fully extended)
- Height: 74.4" (Base & Height w/Arms Folded), 84.4" (with arms fully extended)
- Largest area: 4.27m²
- Maximum user weight: 350 lbs

WARRANTY

10 Years Parts, 1 Year Labor (Commercial)

TABLE OF CONTENTS

IMPORTANT SAFETY NOTICE.....	4
IMPORTANT ASSEMBLY INFORMATION.....	5
ACCESSORIES LIST	7
ASSEMBLY INSTRUCTIONS.....	10
EXPLODED VIEW.....	21
PARTS LIST	22

IMPORTANT SAFETY NOTICE

PRECAUTIONS

This exercise machine is built for optimum safety. However, certain precautions apply whenever you operate a piece of exercise equipment. Be sure to read the entire manual before you assemble or operate your machine. In particular, note the following safety precautions:

1. **Keep children and pets away from the machine at all times. DO NOT leave children unattended in the same room with the machine.**
2. Only one person at a time should use the machine.
3. If the user experiences dizziness, nausea, chest pain, or any other abnormal symptoms, STOP the workout at once. CONSULT A PHYSICIAN IMMEDIATELY.
4. Position the machine on a clear, leveled surface. DO NOT use the machine near water or outdoors.
5. Keep hands away from all moving parts.
6. Always wear appropriate workout clothing when exercising. DO NOT wear robes or other clothing that could become caught in the machine. Running or aerobic shoes are also required when using the machine.
7. Use the machine only for its intended use as described in this manual. DO NOT use attachments not recommended by the manufacturer.
8. Do not place any sharp object around the machine.
9. Disabled person should not use the machine without a qualified person or physician in attendance.
10. Before using the machine to exercise, always do stretching exercises to properly warm up.
11. Never operate the machine if the machine is not functioning properly.

WARNING: BEFORE BEGINNING ANY EXERCISE PROGRAM, CONSULT YOUR PHYSICIAN. THIS IS ESPECIALLY IMPORTANT FOR INDIVIDUALS OVER THE AGE OF 35 OR PERSONS WITH PRE-EXISTING HEALTH PROBLEMS. READ ALL INSTRUCTIONS BEFORE USING ANY FITNESS EQUIPMENT. WE ASSUME NO RESPONSIBILITY FOR PERSONAL INJURY OR PROPERTY DAMAGE SUSTAINED BY OR THROUGH THE USE OF THIS PRODUCT.

SAVE THESE INSTRUCTIONS.

IMPORTANT ASSEMBLY INFORMATION

- ❖ Tools Required for Assembling the Bench: Adjustable Wrench and Allen Wrench.
- ❖ NOTE: It is strongly recommended that this equipment is assembled by two or more people to avoid possible injury.
- ❖ Ensure **Carriage Bolts** are inserted through the **SQUARE holes** on components that need to be assembled. Attach washer only to end of the Carriage Bolt.
- ❖ Use **Allen Bolts or Hex Bolts** inserted through the **ROUND hole** on components that need to be assembled.
- ❖ Always wait until all bolts are assembled onto the bench before tightening the bolts. Do not tighten each bolt right after it is installed

Fasten Nuts and Bolts

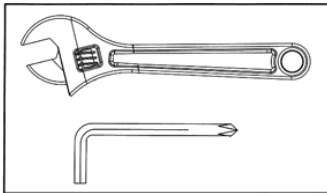

Securely tighten all Nuts and Bolts after all components have been assembled in current and previous steps.
NOTE: Do not over tighten any component with pivoting function.
Make sure all pivoting components are able to move freely.

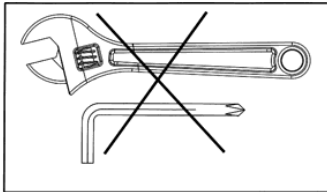

Do not tighten all Nuts and Bolts in this step.

Assembled Dimension: 1314mm x2945mm x2147mm

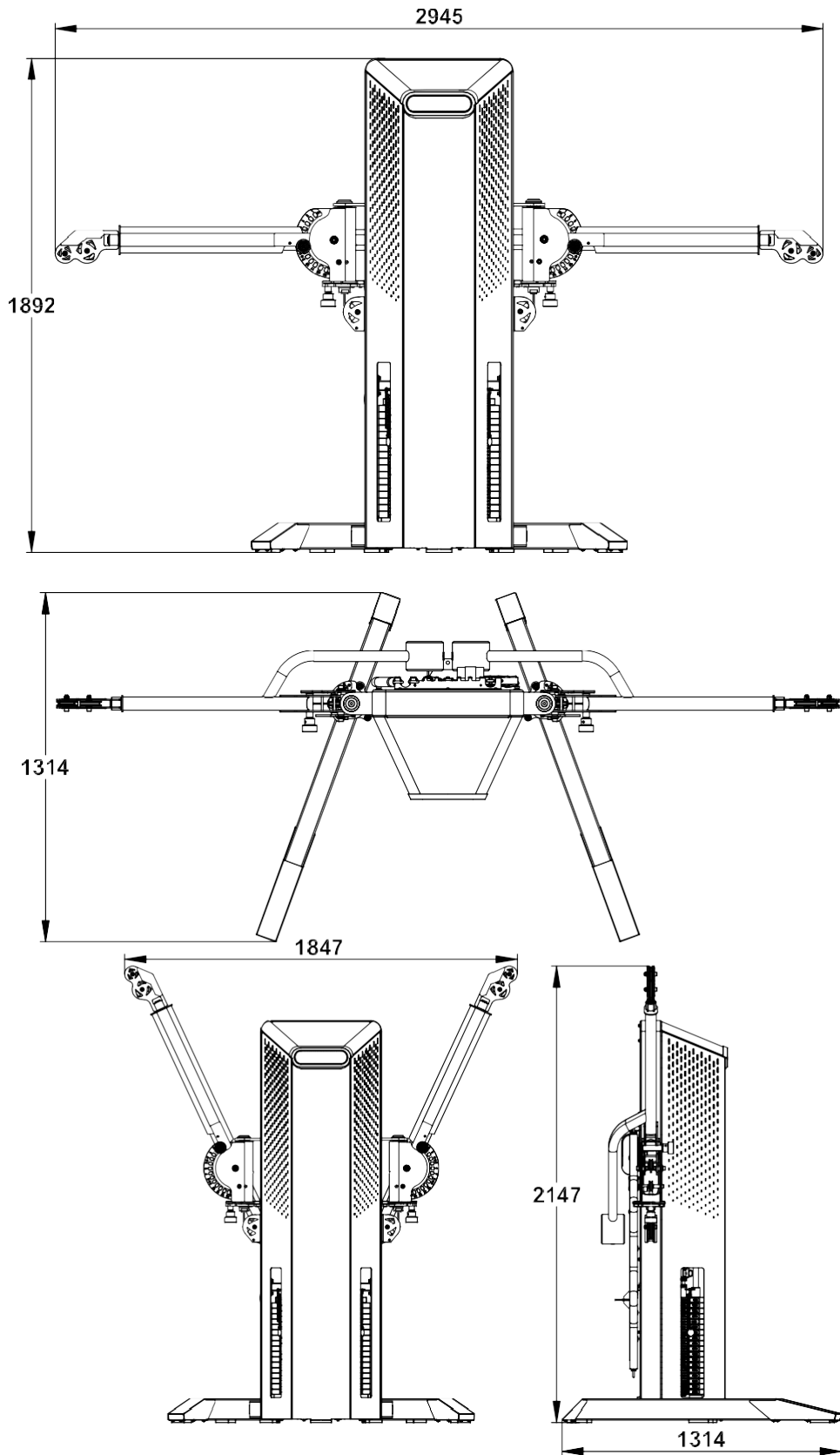

ACCESSORIES LIST

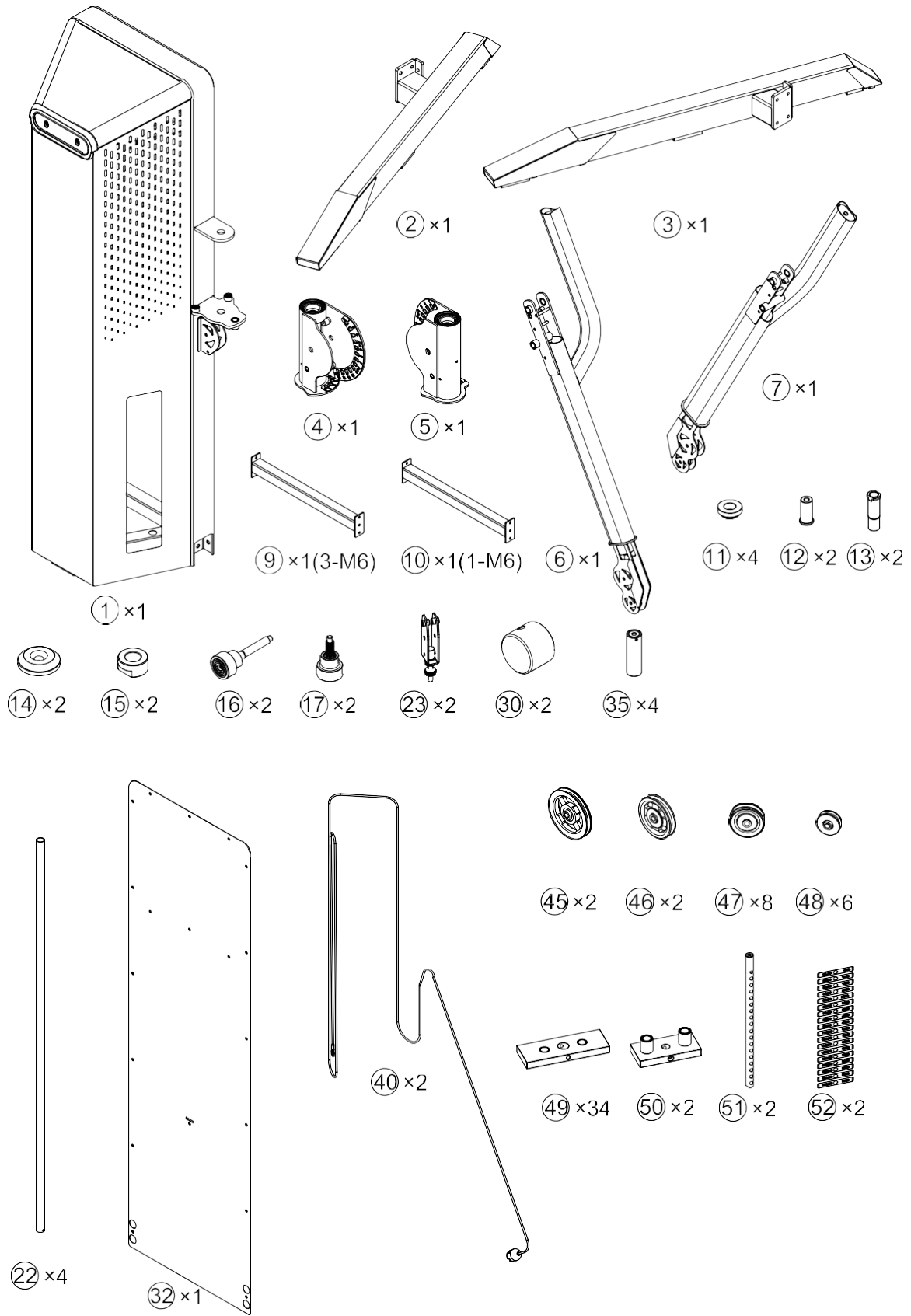

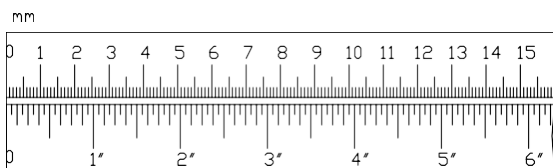
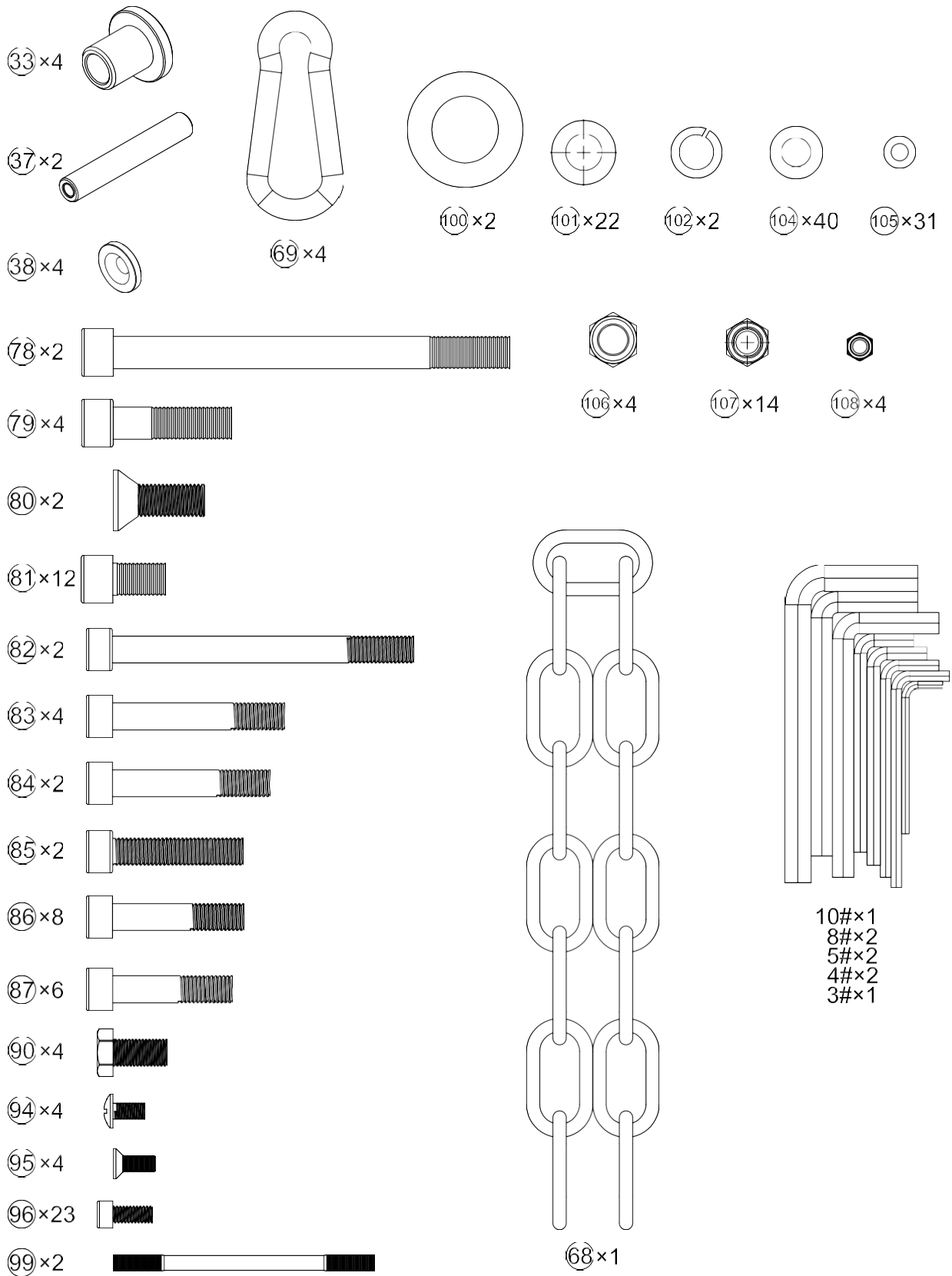

ASSEMBLY INSTRUCTIONS

81



×12 M12×20

101



×12 Φ12

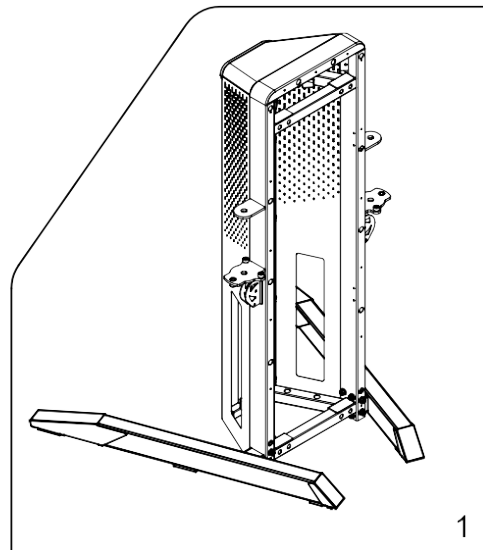
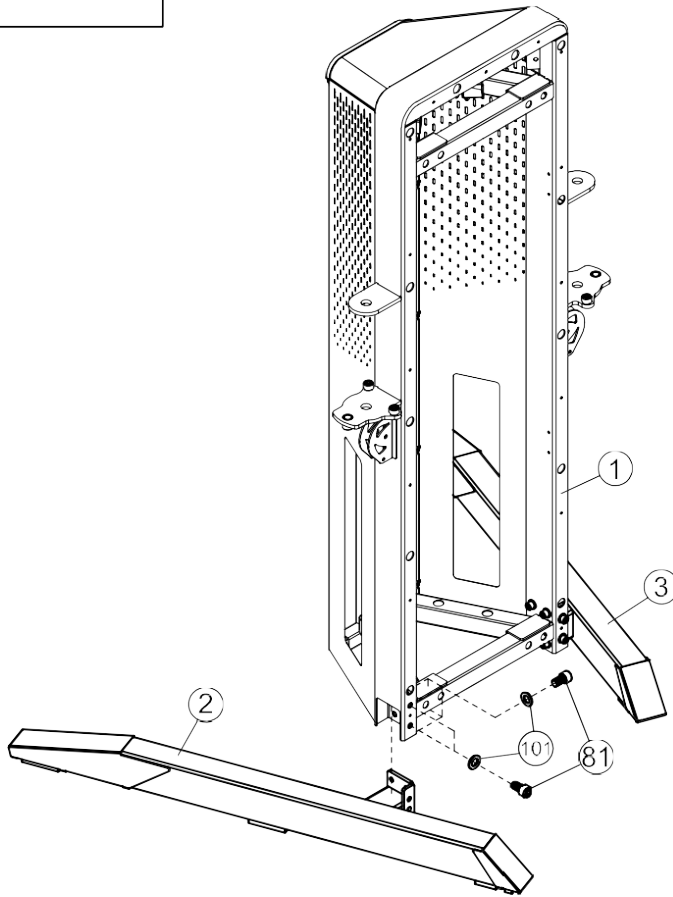
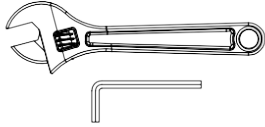

80



×2 M12×35

100



×2 Φ24

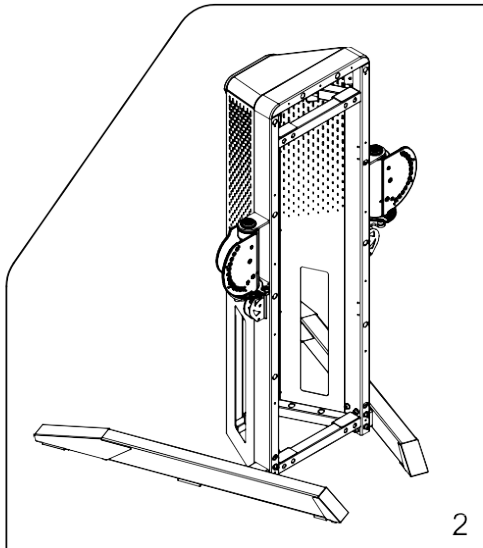
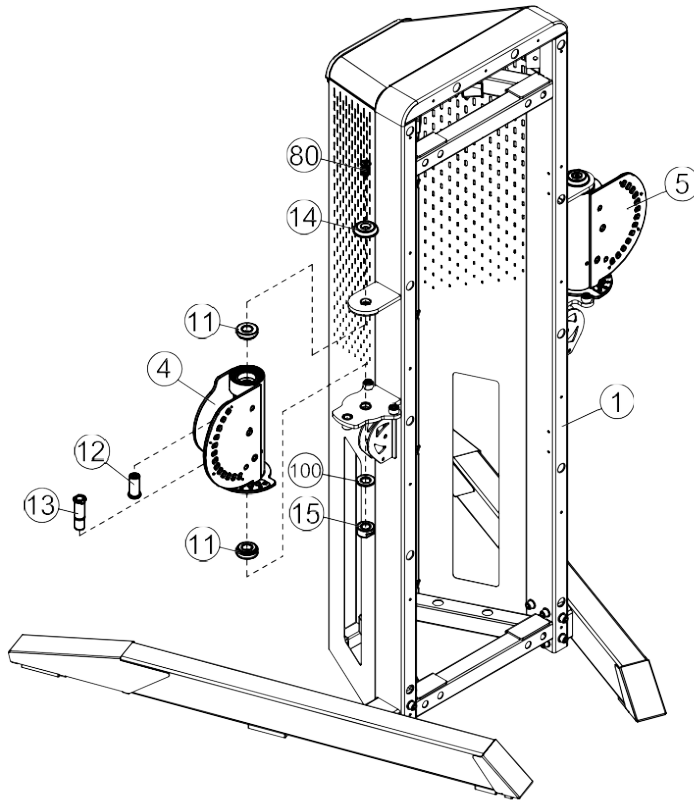
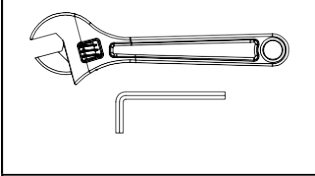

2

90



×4 M10×20

85



×2 M10×55

104



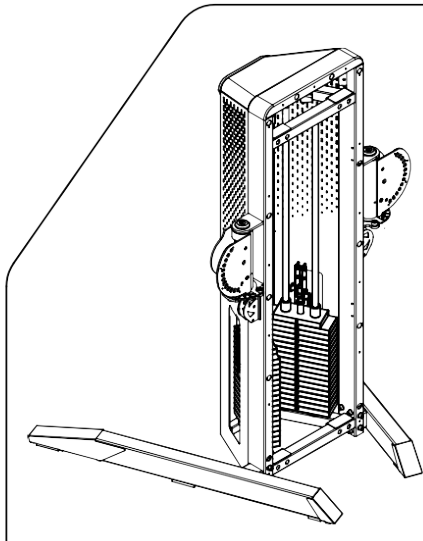
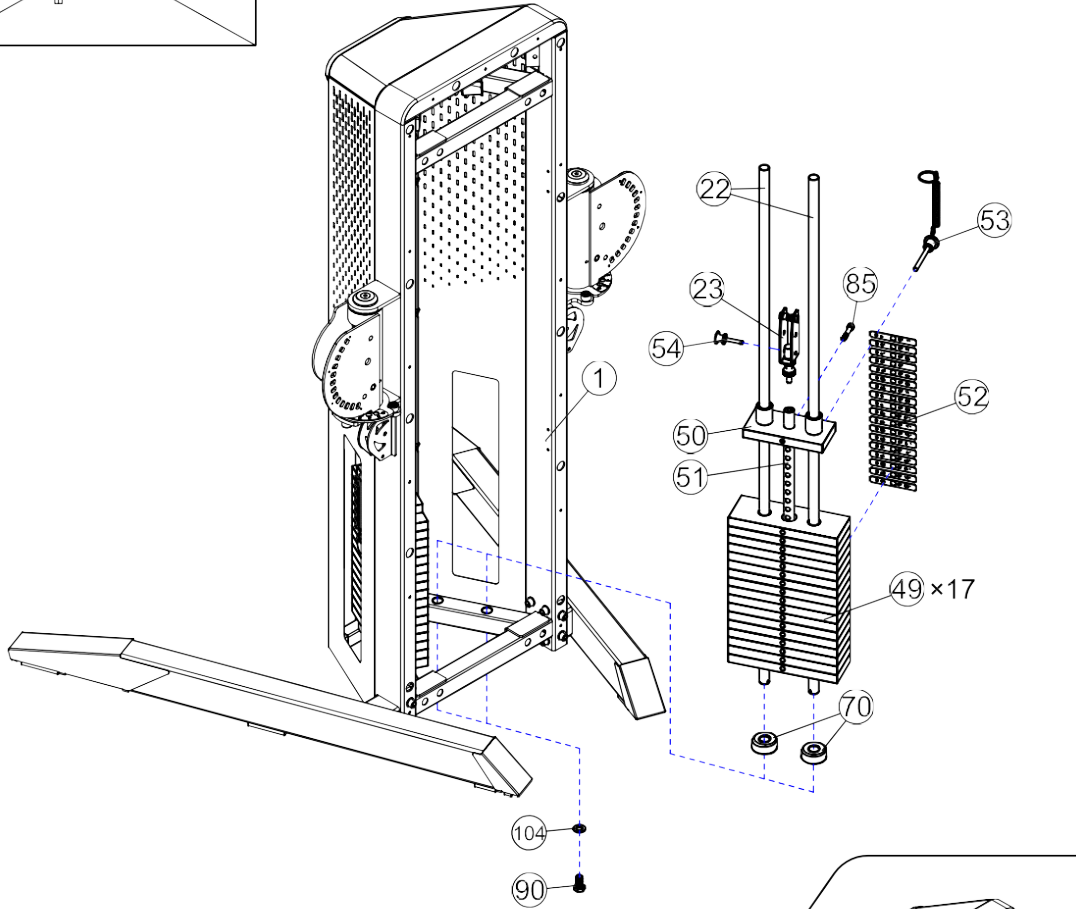
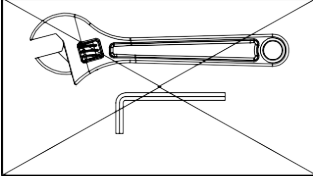

×4 Φ10









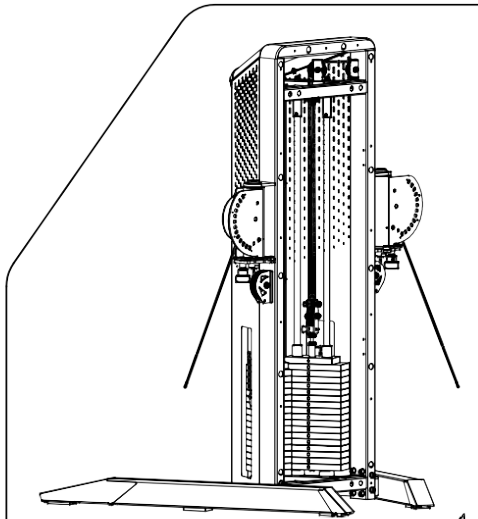
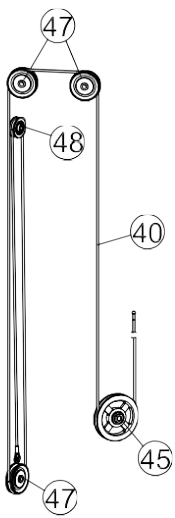
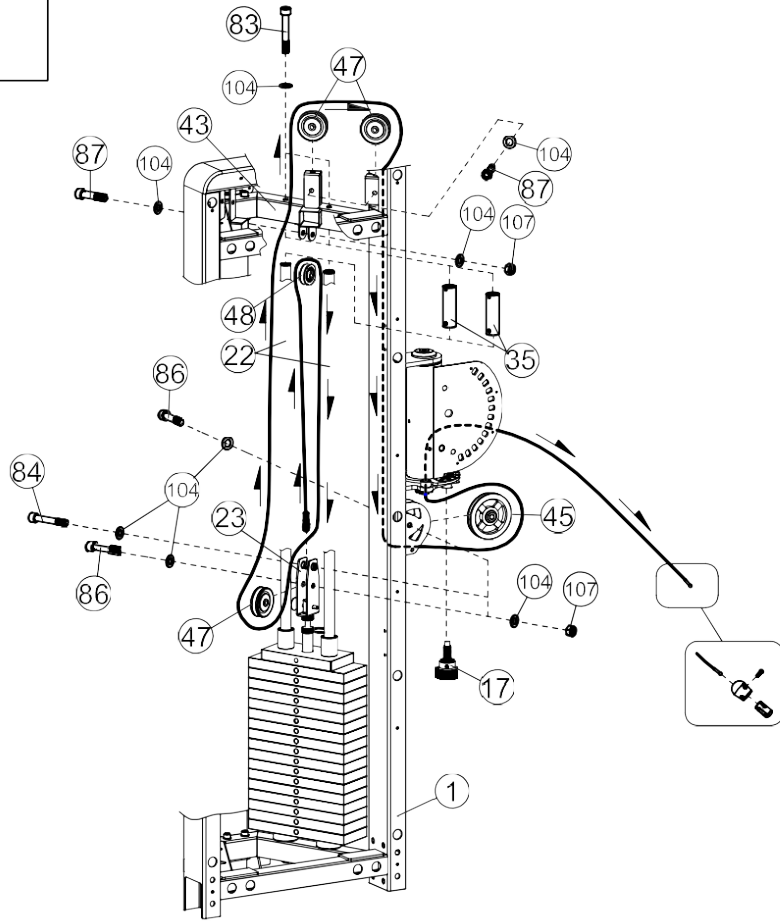
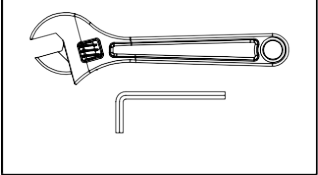





3



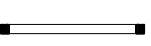

- ⑧③  ×4 M10×65
- ⑧④  ×2 M10×60
- ⑧⑥  ×4 M10×50

- ⑧⑦  ×6 M10×45
- ⑩④  ×24 Φ10
- ⑩⑦  ×8 M10

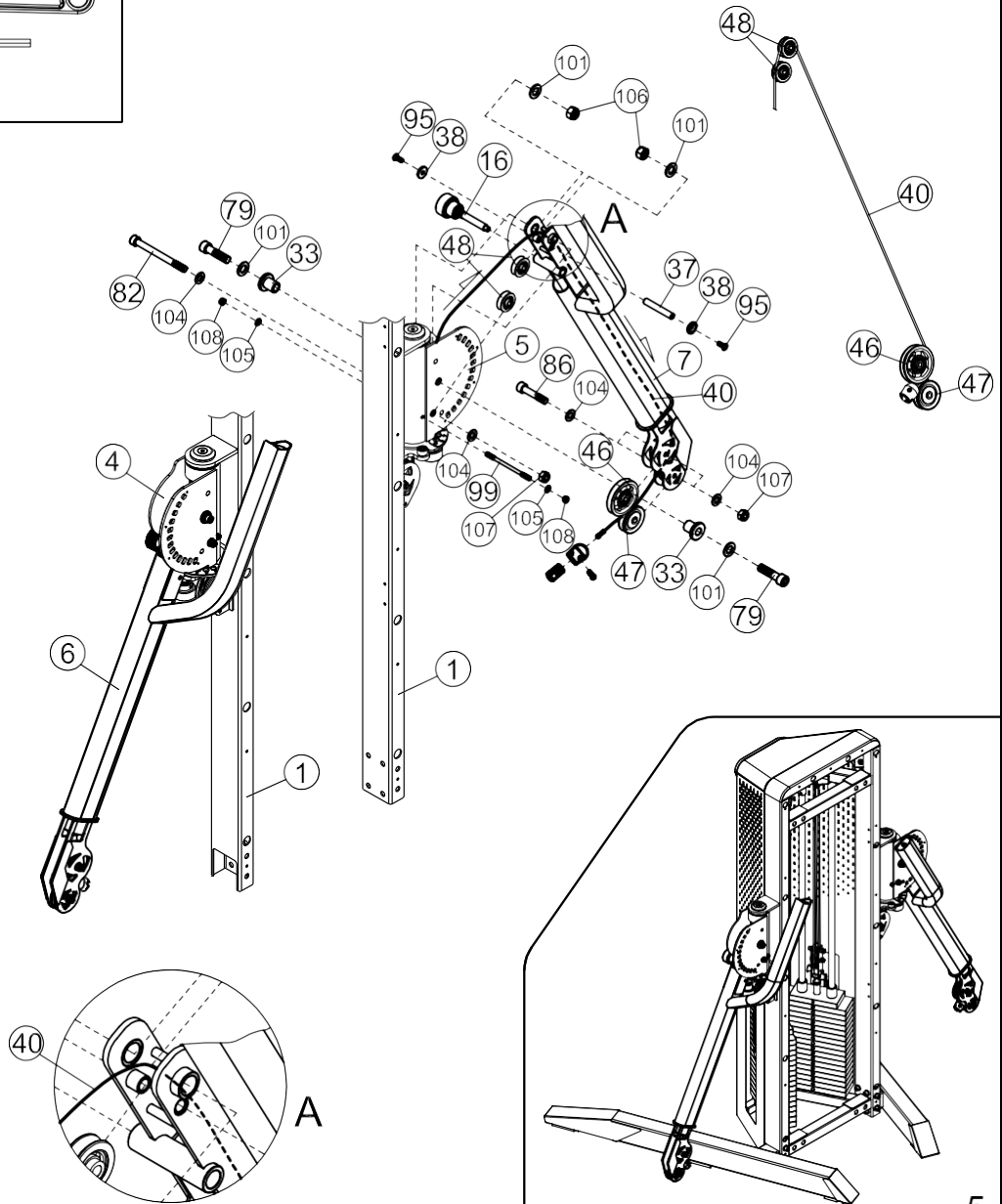
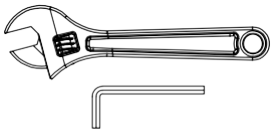

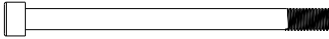
③③		×4	Φ30×Φ18	⑩①		×8	Φ12
③⑦		×2	Φ10×62×M6	⑩④		×12	Φ10
③⑧		×4	Φ20×3	⑩⑤		×4	Φ6
⑦⑨		×4	M12×45	⑩⑥		×4	M12
⑧②		×2	M10×115	⑩⑦		×6	M10
⑧⑥		×4	M10×50	⑩⑧		×4	M6
⑨⑤		×4	M6×16				
⑨⑨		×2	M6×100				



- | | | | |
|-----|---|----|---------|
| 78 |  | ×2 | M12×150 |
| 101 |   | ×2 | Φ12 |
| 102 |   | ×2 | Φ12 |

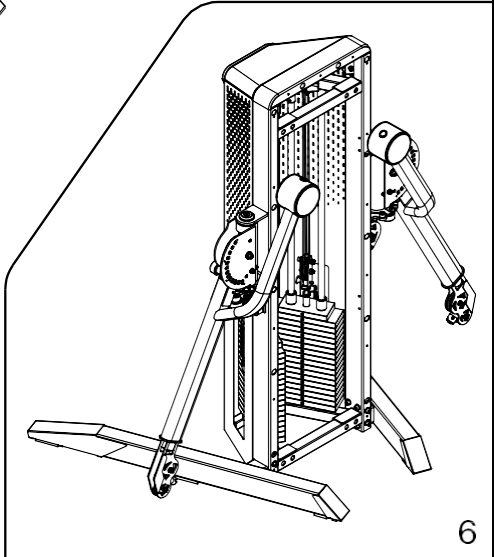
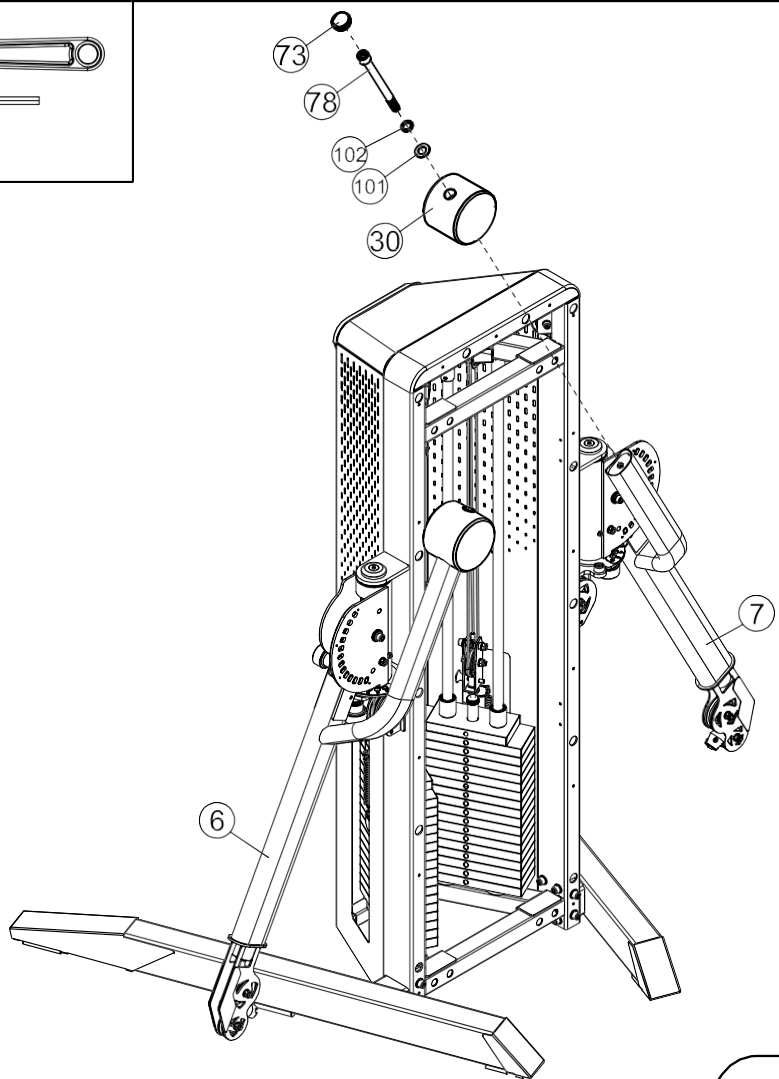
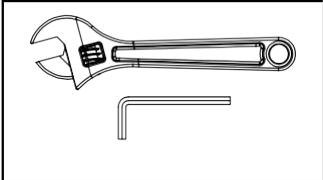

96



×8 M6×15

105



×8 Φ6

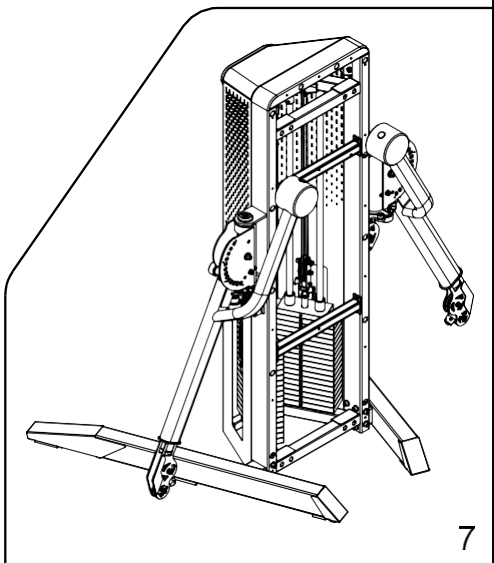
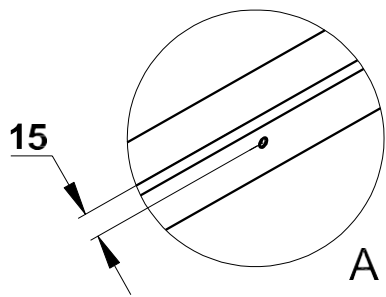
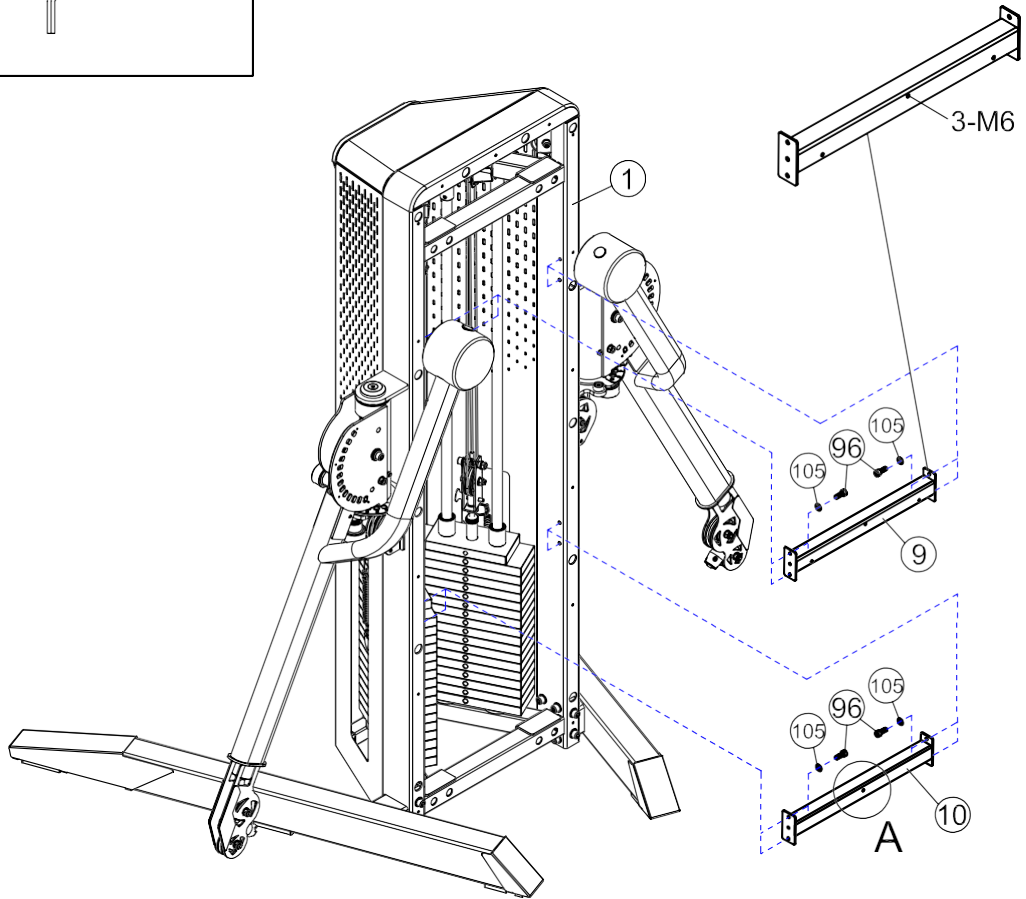
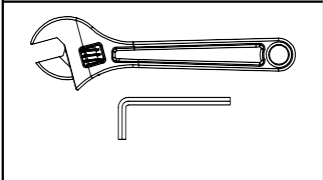

96



x15 M6x15

105



x15 Φ6

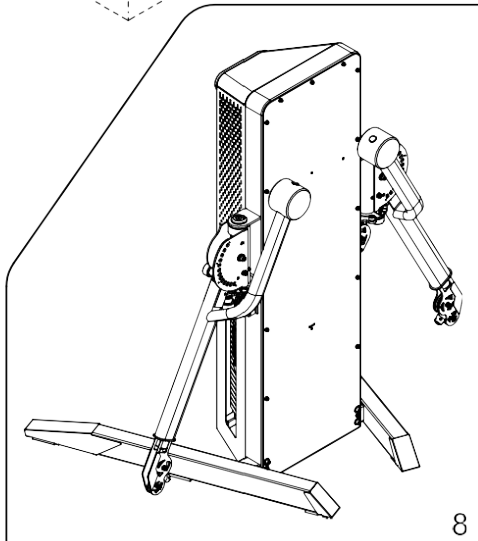
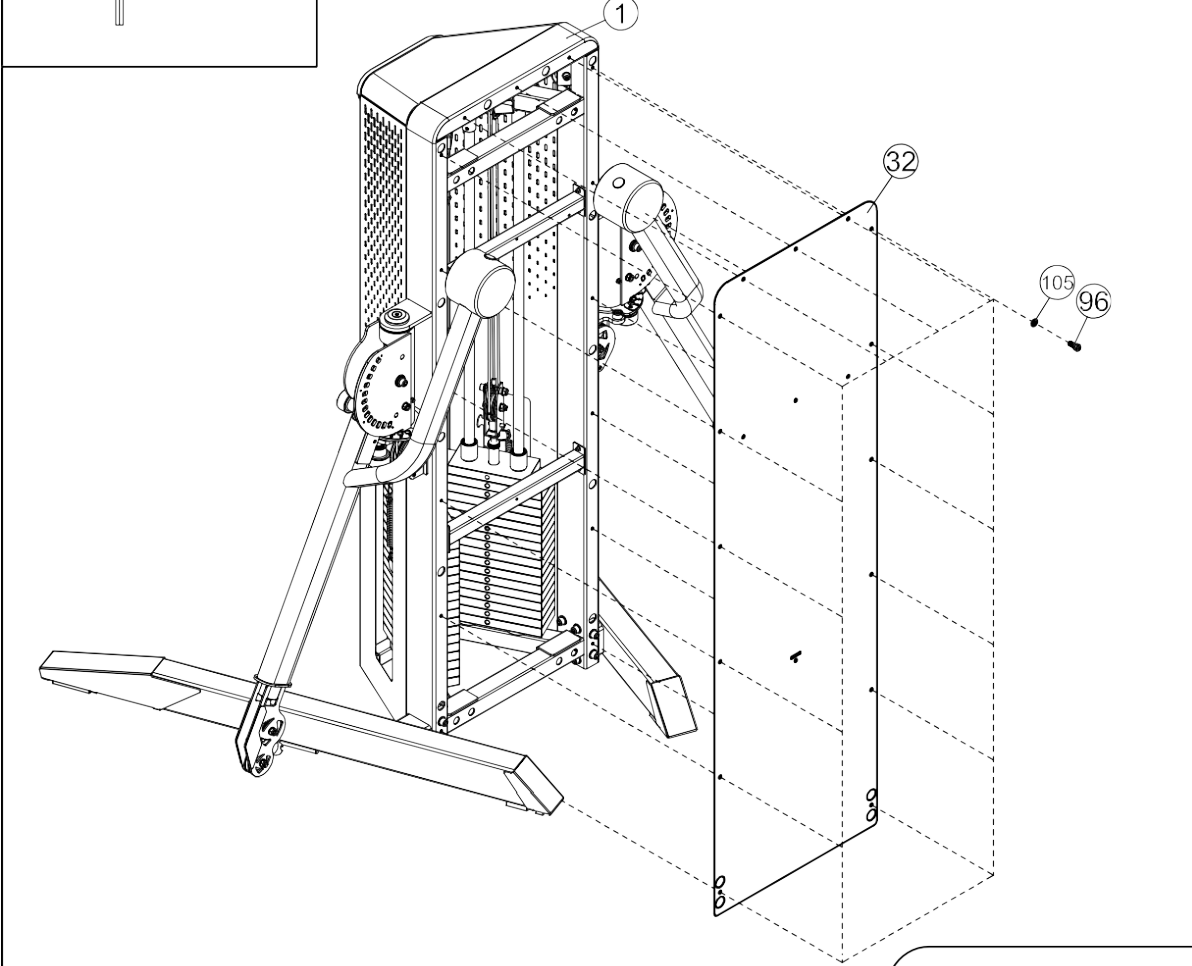
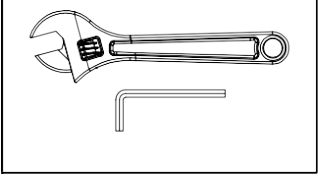

8

94



×4 M6×12

105



×4 Φ6

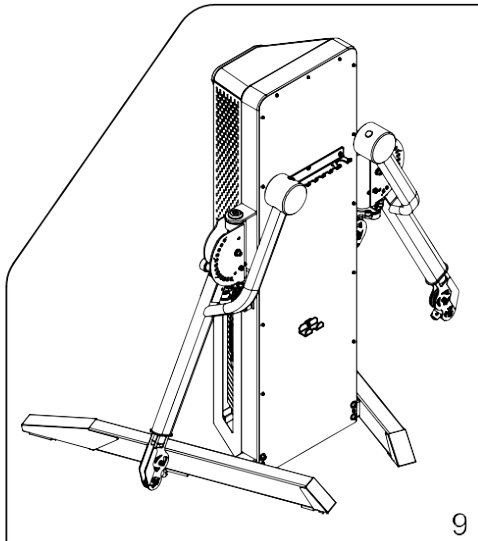
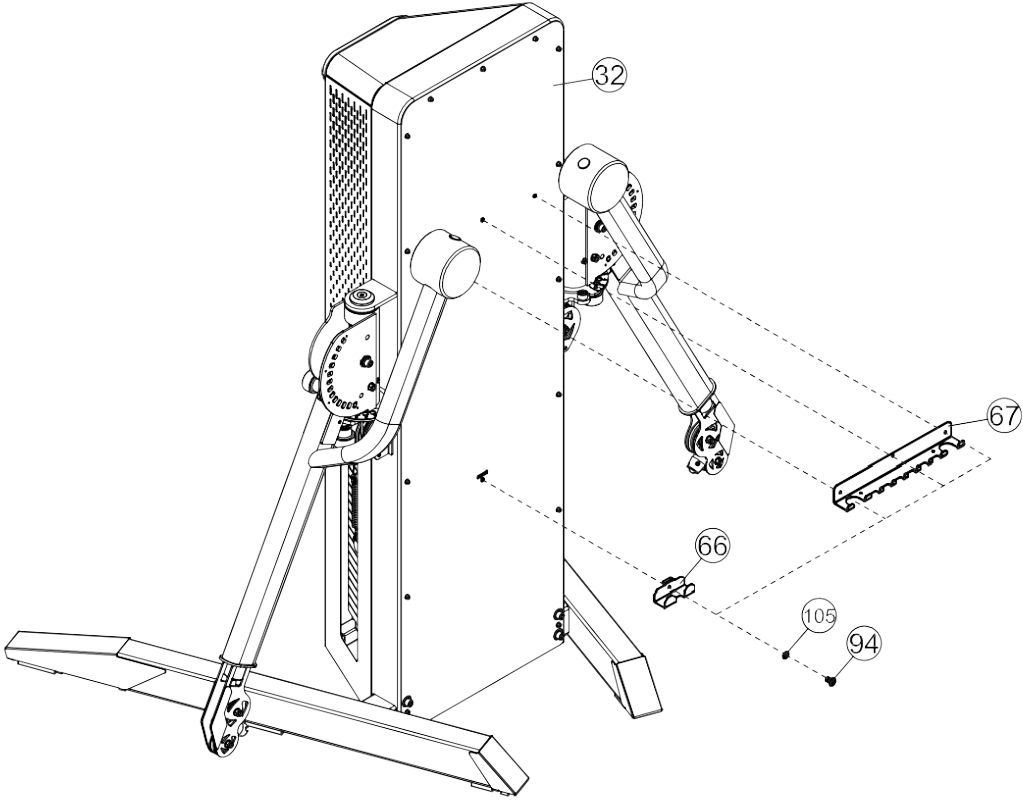
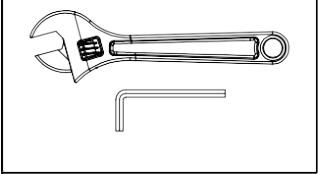

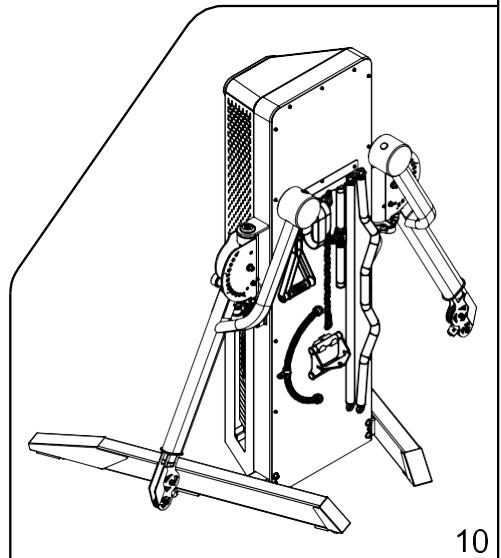
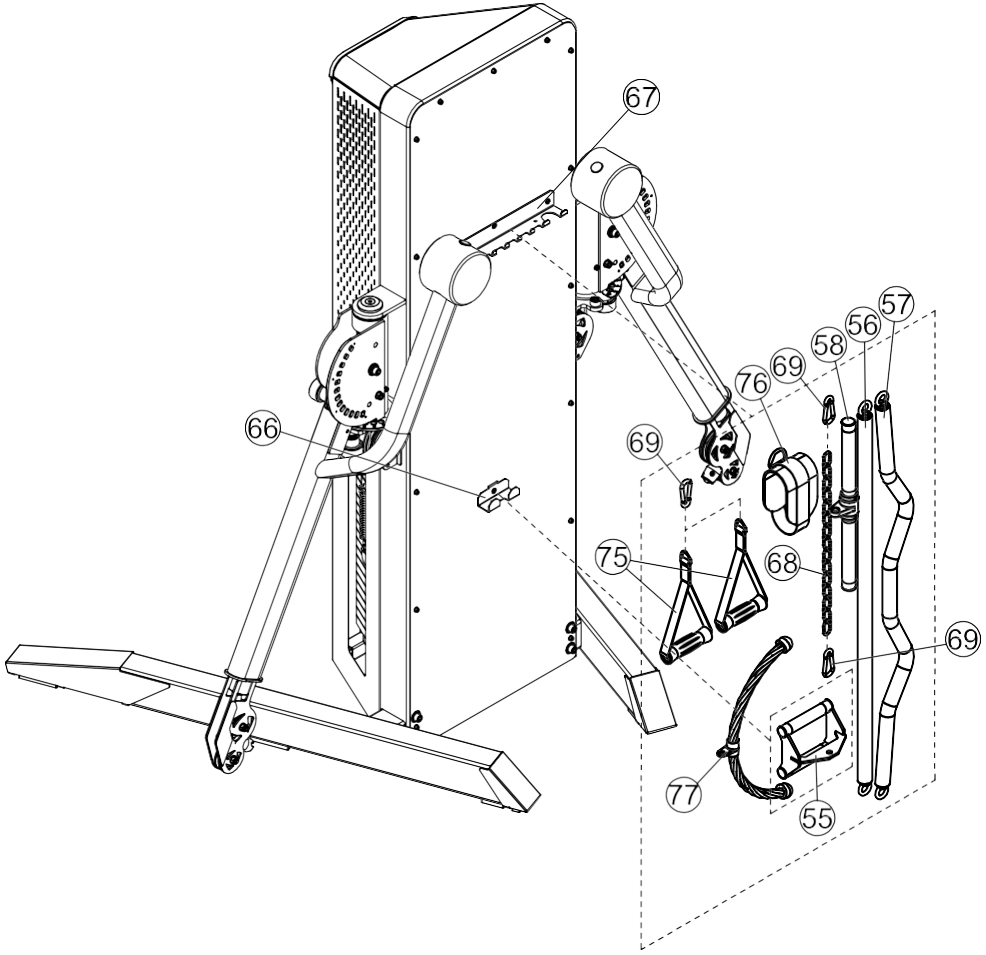

10

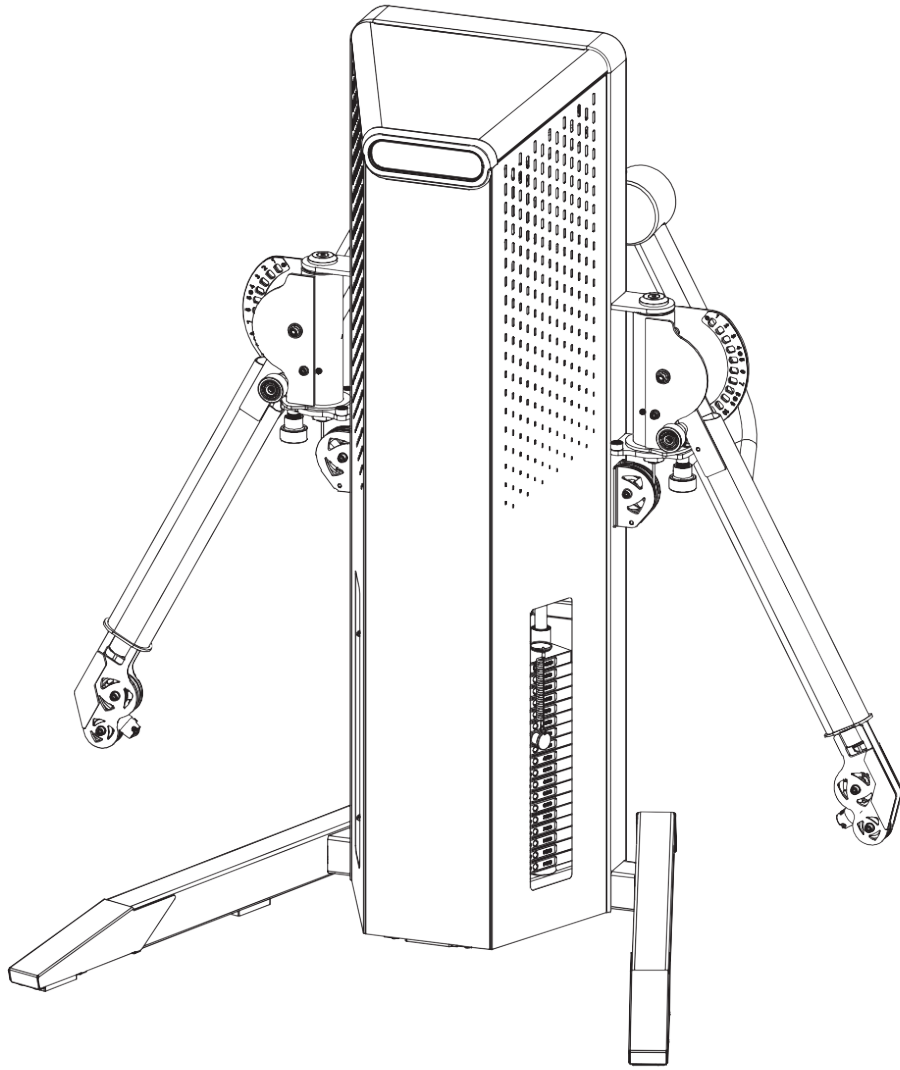

EXPLODED VIEW

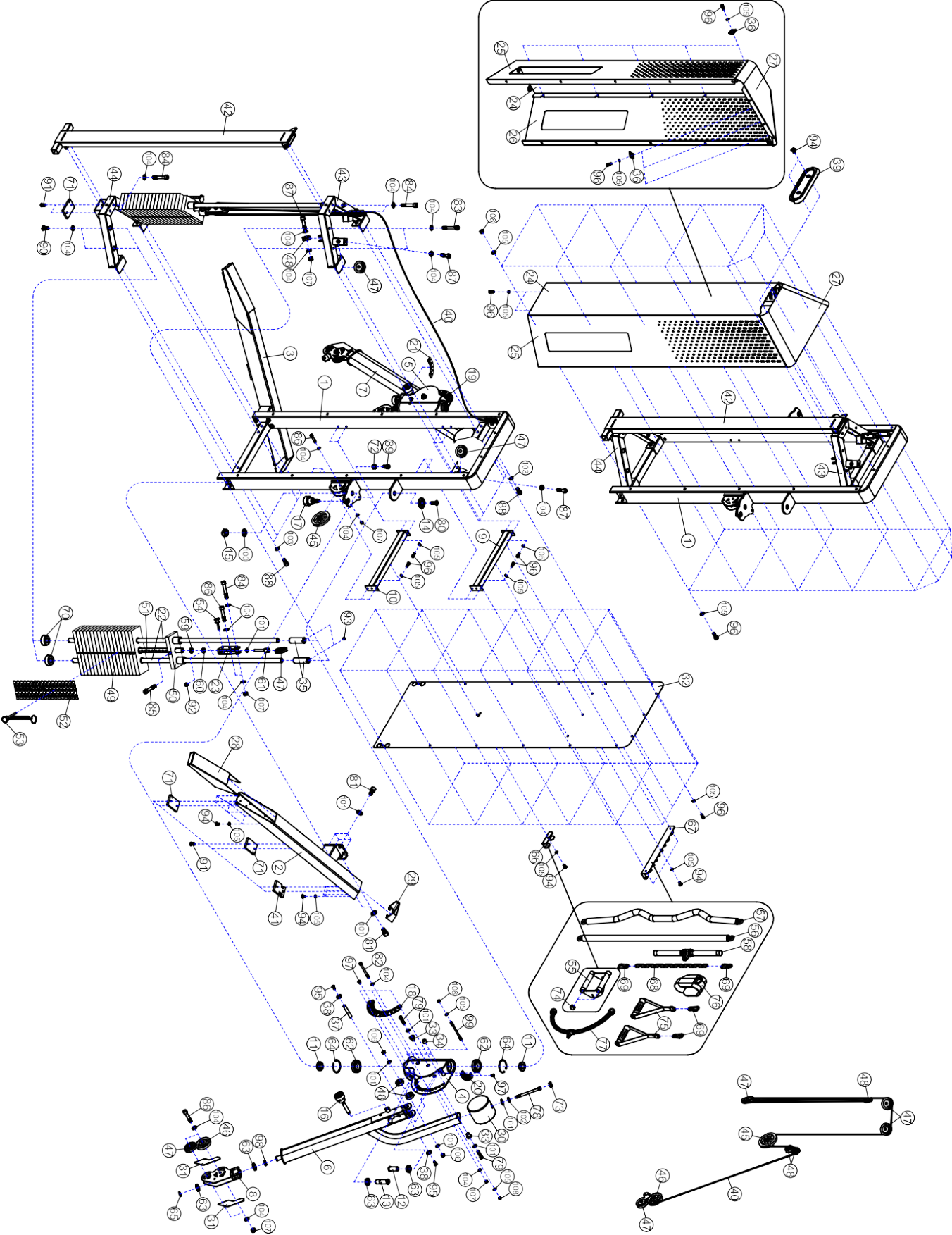

PARTS LIST

KEY NO.	PART DESCRIPTION	SPEC	QTY
1	Rear Post		1
2	Base Frame R		1
3	Base Frame L		1
4	Frame Slider R		1
5	Frame Slider L		1
6	Swing bracket R		1
7	Swing bracket L		1
8	Pulley Case		2
9	Connecting Frame Rear		1
10	Connecting Frame Rear		1
11	Bushing	φ52×φ45×φ25×17	4
12	Core shaft	φ30×φ25×58×M12	2
13	Threaded tube	φ30×φ25×φ18×87×M24×2	2
14	Decorative cover	φ60×13	2
15	Screw	φ42×20×M24×2	2
16	Aluminum alloy plug		2
17	Aluminum alloy plug		2
18	Angle decorative board	266×137×2×R149	1
19	Angle decorative board	266×137×2×R149	1
20	Angle decorative board	102×85×2×R85	1
21	Angle decorative board	102×85×2×R85	1
22	Guide rod	φ25×1530	4
23	Plum fixed bracket		2
24	Protecting mask	1700×275×1	1
25	Protecting mask	1823×330×1	1
26	Protecting mask	1823×330×1	1
27	Protecting mask	575×283×1	1
28	Decorative plates	444×76×2	2
29	Decorative plates	162.5×76×2	2
30	Weight Plate	φ140×110	2
31	Decorative plates	167×57×30×2	4
32	Protecting mask	1869×558×1	1
33	Bushing	Φ30×Φ18×Φ12.2×26	4
34	Bushing	φ19×18	4
35	Guide rod fixed rod		4
36	U-shaped fixed clip	24×20×M6	16
37	Core shaft	φ10×62×M6	2
38	Washer	φ20×3	4
39	Protecting mask	298×107×20	1
40	Double pull cable	(φ5)	2
41	Rubber Stopper	65×100×12	2
42	Standing frame		1
43	Connecting rack		1
44	Connecting rack		1
45	Pulley with Bearings	φ114Xφ10	2
46	Pulley with Bearings	φ95×φ10×18	2

KEY NO.	PART DESCRIPTION	SPEC	QTY
47	Pulley with Bearings	φ72×φ10	8
48	Pulley with Bearings	φ50×φ10	6
49	Weight Plate	280×100×25.4 (5KG)	34
50	Top Weight Plate	205×100×72	2
51	Selector Rod	φ25×513	2
52	Weight Plate Sticker (90kg)	119×17.5	2
53	Weight Selector Pin		2
54	Aluminum alloy plug		2
55	V-type handle		1
56	Straight Bar	L=1115mm	1
57	Cambered Bar	L=1150mm	1
58	Small grip frame	L=480mm	1
59	Screw	φ28×12×M12	2
60	Bushing	φ28×φ12.5×12	2
61	Bolt	φ22×105×M12	2
62	Deep groove ball bearing	6009(75×45×16)	4
63	Deep groove ball bearing	61905	8
64	Hole circlip	75	4
65	Elastic block-A type of shaft	25	2
66	Hangre	37×34×27×10×2	1
67	Long hangre	400×50×50×3	1
68	15-Joint Chain	15	1
69	Hook	φ8	4
70	Rubber Stopper	φ62×φ24.5×25	4
71	Rubber Stopper	65×100×12	5
72	Rubber sleeve	φ25×φ11×14	4
73	Rectangular End Cap	φ30	2
74	Rectangular End Cap	φ28	4
75	Nylon Strap Iso-Handle	L=245mm	2
76	Ankle Strap		1
77	Rope	φ29×695	1
78	Hexagon socket button head screws	M12×150	2
79	Hexagon socket button head screws	M12×45	4
80	Hex socket counter sunk head screw	M12×35	2
81	Hexagon socket button head screws	M12×20	12
82	Hexagon socket button head screws	M10×115	2
83	Hexagon socket button head screws	M10×65	4
84	Hexagon socket button head screws	M10×60	6
85	Hexagon socket button head screws	M10×55	2
86	Hexagon socket button head screws	M10×50	8
87	Hexagon socket button head screws	M10×45	6
88	Hexagon socket button head screws	M10×20	8
89	Hexagon socket button head screws	M10×16	4
90	Hex Bolts	M10×20	4
91	Allen Bolt	M8×16	14
92	Set screw	M8×8	2

KEY NO.	PART DESCRIPTION	SPEC	QTY
93	Set screw	M8×6	4
94	Cross recessed pan head screws	M6×12	26
95	Hex socket counter sunk head screw	M6×16	4
96	Hexagon socket button head screws	M6×15	53
97	Cross Sink Calf Screw	M4×8	12
98	Retaining ring	φ30×φ25.5×3	2
99	Equal-length double head studs	M6×100	2
100	Washer	24	2
101	Washer	12	24
102	Washer	12	2
103	Washer	10	8
104	Washer	10	44
105	Washer	6	93
106	Hex nuts	M12	4
107	Hex nuts	M10	14
108	Hex nuts	M6	16
	Allen wrench	10#	1
	Allen wrench	8#	2
	Allen wrench	5#	2
	Allen wrench	4#	2