

# FREEMOTION® *Reflex t 11.3*

Model No. FMTL39813.2

Serial No. \_\_\_\_\_

Write the serial number in the space above for reference.

Serial Number Decal

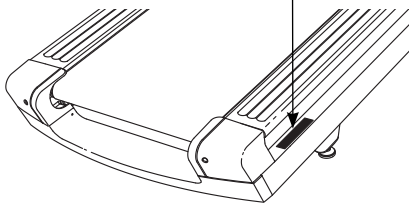

## USER'S MANUAL

### QUESTIONS?

If you have questions, or if parts are damaged or missing, please see **HOW TO CONTACT CUSTOMER CARE** on the back cover of this manual.

### CAUTION

Read all precautions and instructions in this manual before using this equipment. Save this manual for future reference.

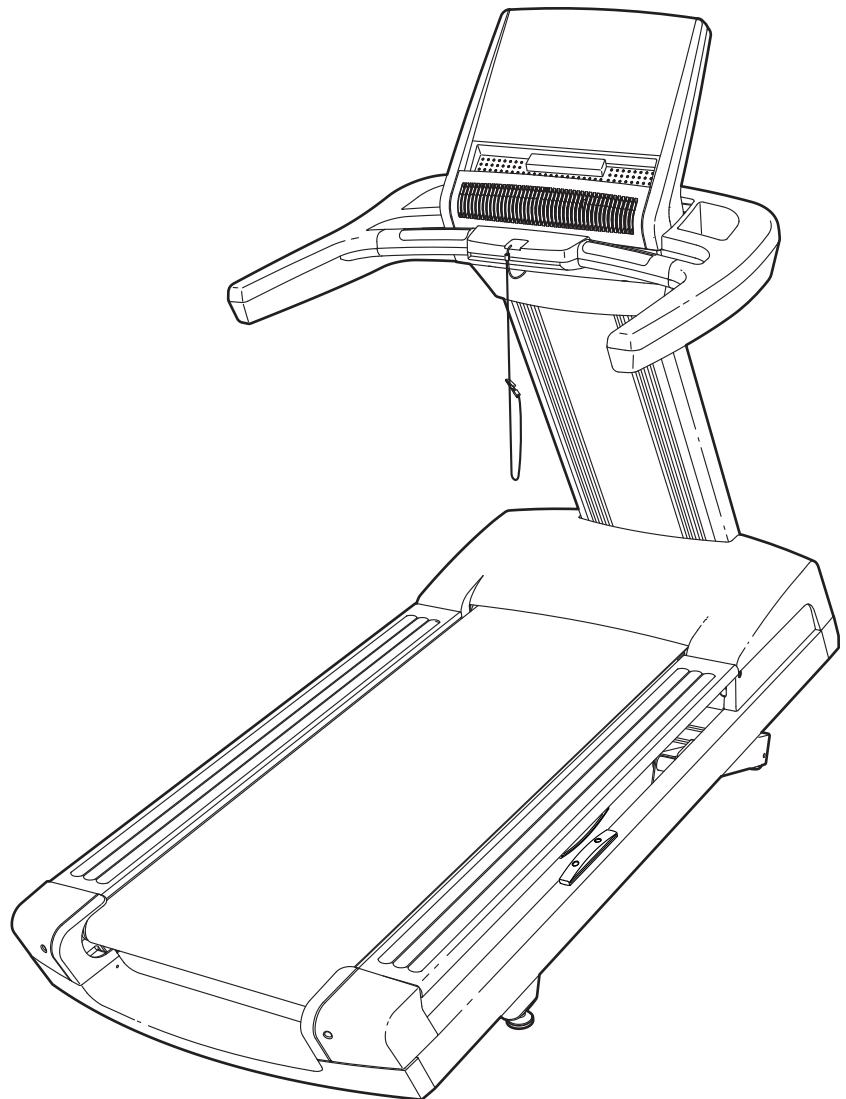

[www.freemotionfitness.com](http://www.freemotionfitness.com)

---

# TABLE OF CONTENTS

WARNING DECAL PLACEMENT .....	3
IMPORTANT PRECAUTIONS .....	4
BEFORE YOU BEGIN .....	6
PART IDENTIFICATION CHART .....	7
ASSEMBLY .....	8
HOW TO USE THE TREADMILL .....	14
HOW TO USE THE CONSOLE .....	15
HOW TO MOVE THE TREADMILL .....	19
PREVENTIVE MAINTENANCE .....	20
SIX-MONTH PREVENTIVE MAINTENANCE RECORD .....	24
TROUBLESHOOTING .....	25
EXERCISE GUIDELINES .....	27
PART LIST .....	30
EXPLODED DRAWING .....	32
HOW TO CONTACT CUSTOMER CARE .....	Back Cover
LIMITED WARRANTY .....	Back Cover

FREEMOTION is a registered trademark of ICON Health & Fitness, Inc.

# WARNING DECAL PLACEMENT

**⚠ WARNING:**

- To reduce the risk of serious injury read warning label before use.

rear warning label

**⚠ CAUTION ⚠ ATTENTION**

KEEP HANDS AND FEET AWAY FROM THIS AREA WHILE THE TREADMILL IS IN OPERATION.

GARDEZ VOS PIEDS ET VOS MAINS ÉLOIGNÉS DE CET ENDROIT QUAND LE TAPIS ROULANT EST EN MARCHÉ.

These drawings show the locations of the warning decals. **If a decal is missing or illegible, see the back cover of this manual and request a free replacement decal. Apply the decal in the location shown. Note: The decals may not be shown at actual size.**

**⚠ WARNING**

- Hazardous Voltage
- Risk of Electric Shock
- Unplug Treadmill before Assembly/ Disassembly

**⚠ ATTENTION**

- Tension Dangereuse
- Risque de Choc Electrique
- Débranchez le tapis roulant Avant l'Assemblage/Désassemblage

**⚠ WARNING:** Protect yourself and others from risk of serious injury. Read the user's manual or obtain proper instruction before use and:

- Stand only on side rails when starting or stopping treadmill.
- Change speed in small increments.
- Hold handrails to prevent falling, and always wear the safety clip while operating treadmill.
- Stop if you feel faint, dizzy, or short of breath.
- Never allow children on or around treadmill.
- Remove key when not in use.
- Keep clothing, fingers, and hair away from moving belt.
- Never try to adjust or fix the belt while it is moving.
- Always wear athletic shoes while operating treadmill.

# IMPORTANT PRECAUTIONS

**⚠️ WARNING:** To reduce the risk of burns, fire, electric shock, or injury to persons, read all important precautions and instructions in this manual and all warnings on your treadmill before using your treadmill. FreeMotion Fitness assumes no responsibility for personal injury or property damage sustained by or through the use of this product.

1. Before beginning this or any exercise program, consult your physician. This is especially important for persons over age 35 or persons with pre-existing health problems.
2. It is the responsibility of the owner to ensure that all users of this treadmill are adequately informed of all warnings and precautions.
3. Use the treadmill only as described.
4. Keep the treadmill indoors, away from moisture and dust. Do not put the treadmill in a garage or covered patio, or near water.
5. Place the treadmill on a level surface, with at least 8 ft. (2.4 m) of clearance behind it and 2 ft. (0.6 m) on each side. Do not place the treadmill on any surface that blocks air openings. To protect the floor or carpet from damage, place a mat under the treadmill.
6. Do not operate the treadmill where aerosol products are used or where oxygen is being administered.
7. Keep children under age 12 and pets away from the treadmill at all times.
8. The treadmill should be used only by persons weighing 400 lbs. (181 kg) or less.
9. Never allow more than one person on the treadmill at a time.
10. Wear appropriate exercise clothes when using the treadmill. Do not wear loose clothes that could become caught in the treadmill. Athletic support clothes are recommended for both men and women. *Always wear athletic shoes. Never use the treadmill with bare feet, wearing only stockings, or in sandals.*
11. When connecting the power cord, follow the instructions on page 13. No other appliance should be on the same circuit as the treadmill. Do not use an extension cord.
12. Keep the power cord away from heated surfaces.
13. Never move the walking belt while the power is turned off. Do not operate the treadmill if the power cord or plug is damaged, or if the treadmill is not working properly. (See TROUBLESHOOTING on page 25 if the treadmill is not working properly.)
14. Read, understand, and test the emergency stop procedure before using the treadmill (see HOW TO TURN ON THE POWER on page 16).
15. Never start the treadmill while you are standing on the walking belt. Always hold the handrails while using the treadmill.
16. The treadmill is capable of high speeds. Adjust the speed in small increments to avoid sudden jumps in speed.
17. The heart rate monitor is not a medical device. Various factors, including the user's movement, may affect the accuracy of heart rate readings. The heart rate monitor is intended only as an exercise aid in determining heart rate trends in general.
18. Never leave the treadmill unattended while it is running. Always remove the key, press the power switch into the off position (see the drawing on page 6 for the location of the power switch), and unplug the power cord when the treadmill is not in use.

19. Do not attempt to move the treadmill until it is properly assembled. (See ASSEMBLY on page 8, and HOW TO MOVE THE TREADMILL on page 19.) You must be able to safely lift 45 lbs. (20 kg) to move the treadmill.

20. Do not change the incline of the treadmill by placing objects under the treadmill.

21. Inspect and properly tighten all parts of the treadmill regularly.

22. Never insert or drop any object into any opening on the treadmill.

23. **DANGER:** Always unplug the power cord immediately after use, before cleaning

the treadmill, and before performing the maintenance and adjustment procedures described in this manual. Never remove the motor hood unless instructed to do so by an authorized service representative. Servicing other than the procedures in this manual should be performed by an authorized service representative only.

24. Over exercising may result in serious injury or death. If you feel faint or if you experience pain while exercising, stop immediately and cool down.

**SAVE THESE INSTRUCTIONS**

# BEFORE YOU BEGIN

Thank you for selecting the revolutionary FREEMOTION® REFLEX T 11.3 treadmill. The REFLEX T 11.3 treadmill offers an impressive selection of features designed to make your workouts more enjoyable and effective.

**For your benefit, read this manual carefully before using the treadmill.** If you have questions after

reading this manual, please see the back cover of this manual. To help us assist you, note the product model number and serial number before contacting us. The model number and the location of the serial number decal are shown on the front cover of this manual.

Before reading further, please review the drawing below and familiarize yourself with the labeled parts.

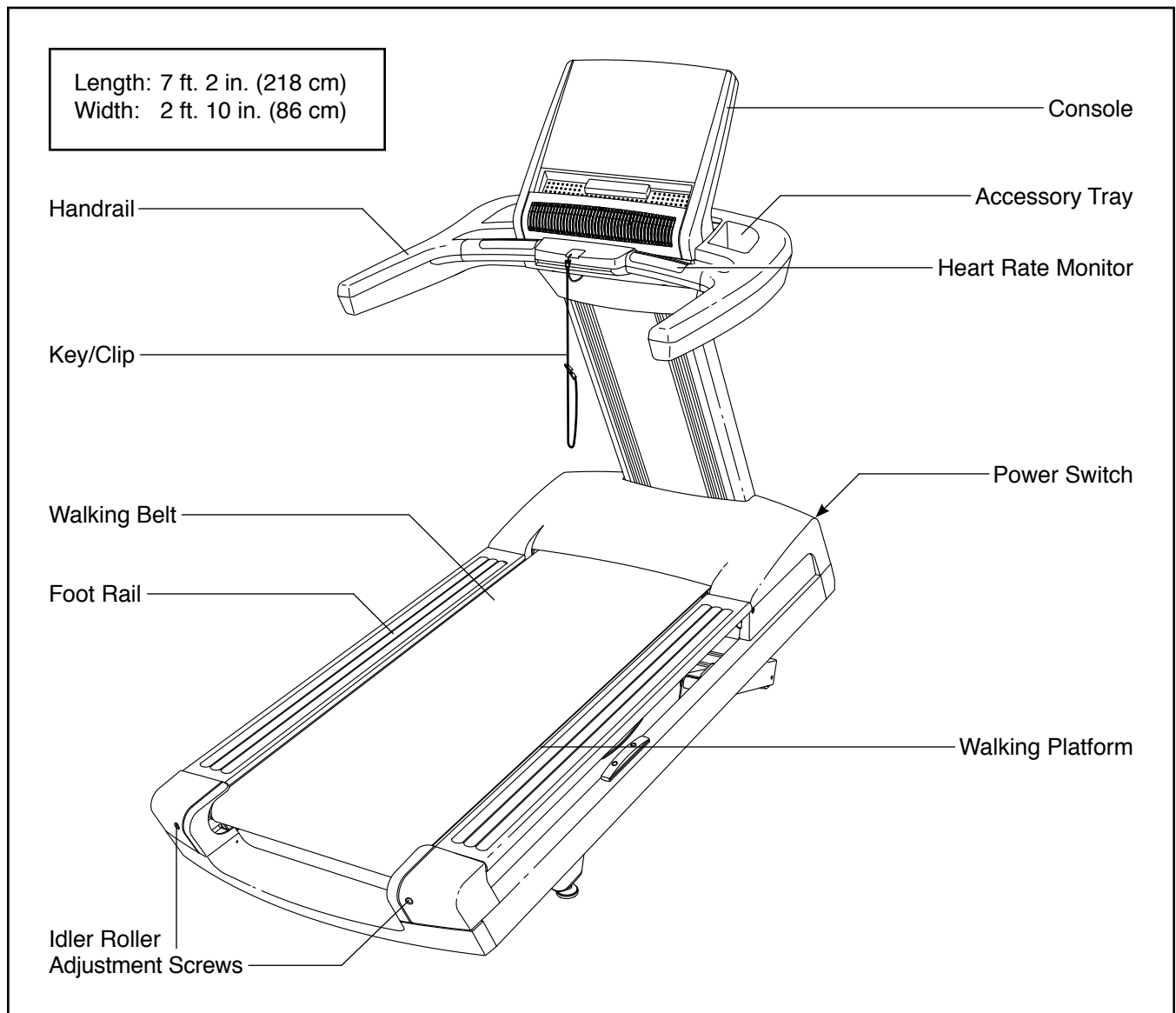

# PART IDENTIFICATION CHART

Use the drawings below to identify small parts used for assembly. The number in parentheses below each drawing is the key number of the part, from the PART LIST near the end of this manual. The number following the key number is the quantity used for assembly. **Note: If a part is not in the hardware kit, check to see whether it is preattached. Extra hardware may be included.**

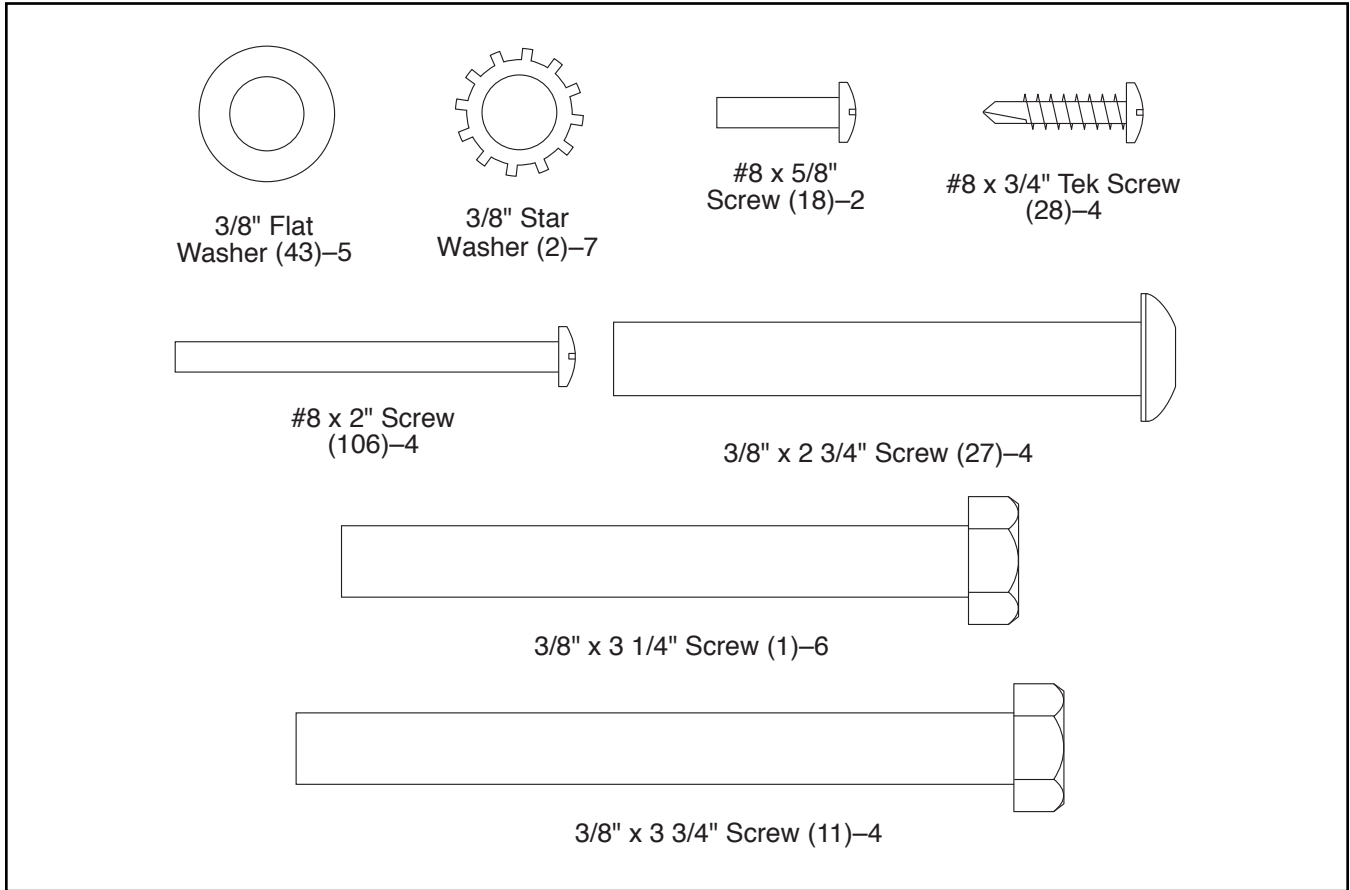

# ASSEMBLY

- Assembly requires two persons.
- Place all parts in a cleared area and remove the packing materials. Do not dispose of the packing materials until you finish all assembly steps.
- To identify small parts, see page 7.
- After shipping, there may be an oily substance on the exterior of the treadmill. This is normal. If there is an oily substance on the treadmill, wipe it off with a soft cloth and a mild, non-abrasive cleaner.

- Assembly requires the following tools:

the included hex key



one adjustable wrench



one Phillips screwdriver

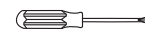

To avoid damaging parts, do not use power tools.

1. **Make sure that the power cord is unplugged. Be careful not to pinch the power cord.**

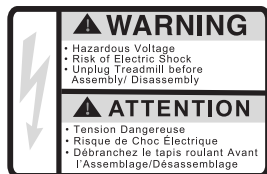

Slide the Upright Cover (not shown) off the Upright (81).

Orient the Upright (81) and the plastic ties as shown. Set the Upright on the tabs on the Frame (53). Then, attach the Upright with six 3/8" x 3 1/4" Screws (1), three 3/8" Star Washers (2), and three 3/8" Flat Washers (43). **Start all six Screws, and then tighten them. Make sure not to pinch any wires.**

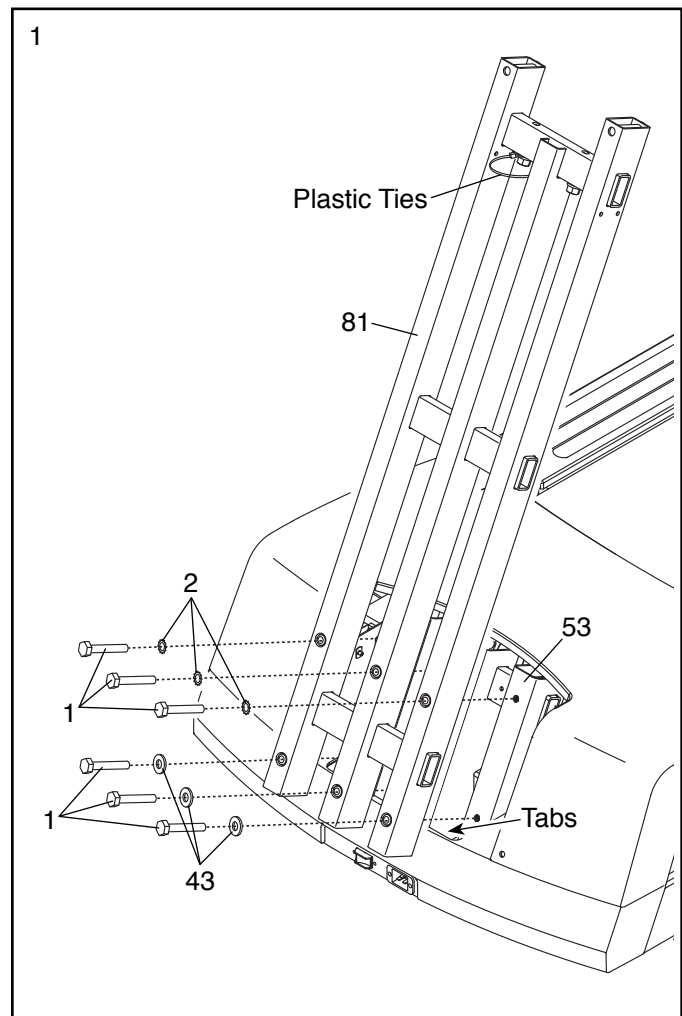



2. Insert the end of the Upright Wire (111) through the looped plastic tie at the top of the Upright (81). **Make sure that the Upright Wire is behind the crossbars on the Upright.** Then, gently pull upward on the Upright Wire as you tighten the plastic ties around the Upright Wire.

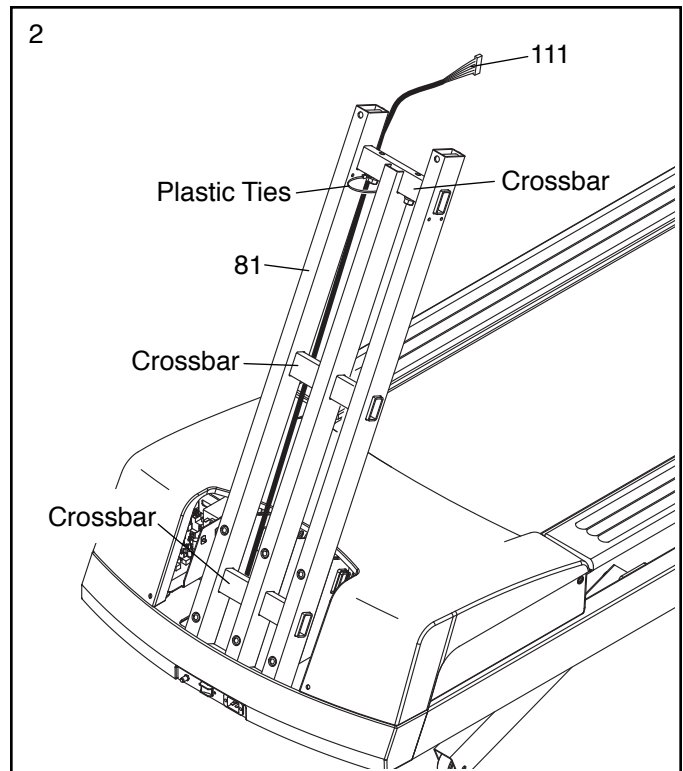

3. Slide the Upright Cover (80) downward onto the Upright (81). **Make sure not to pinch the Upright Wire (111). Make sure not to hit the ceiling with the Upright Cover.**

Next, orient the Upright Collar (105) so that the sticker is on the indicated side. Slide the Upright Collar onto the Upright Cover (80).

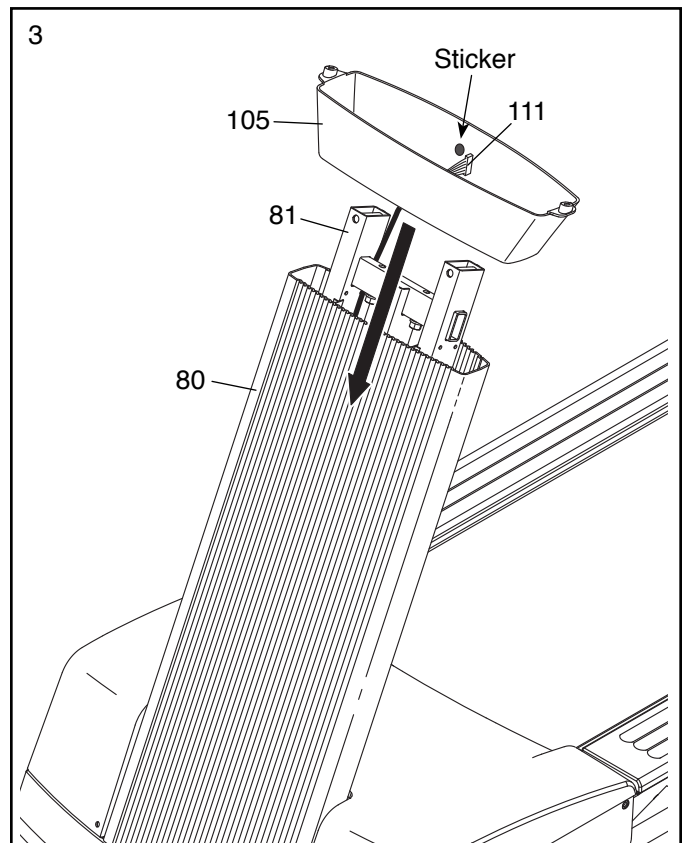

4. Have a second person hold the handrail assembly near the Upright (81). Insert the Upright Wire (111) upward through the center of the handrail assembly.

Then, slide the bracket on the handrail assembly over the crossbar on the Upright (81), and set the handrail assembly on the Upright. **Make sure not to pinch any wires.**

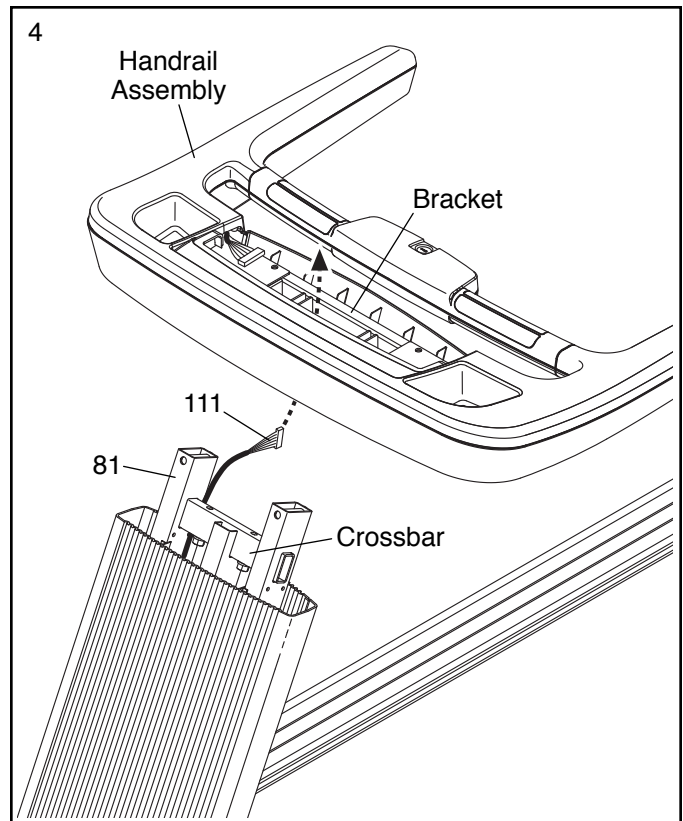

5. Attach the handrail assembly with two 3/8" x 3 3/4" Screws (11) and two 3/8" Star Washers (2). **Do not fully tighten the Screws yet. Make sure not to pinch any wires.**

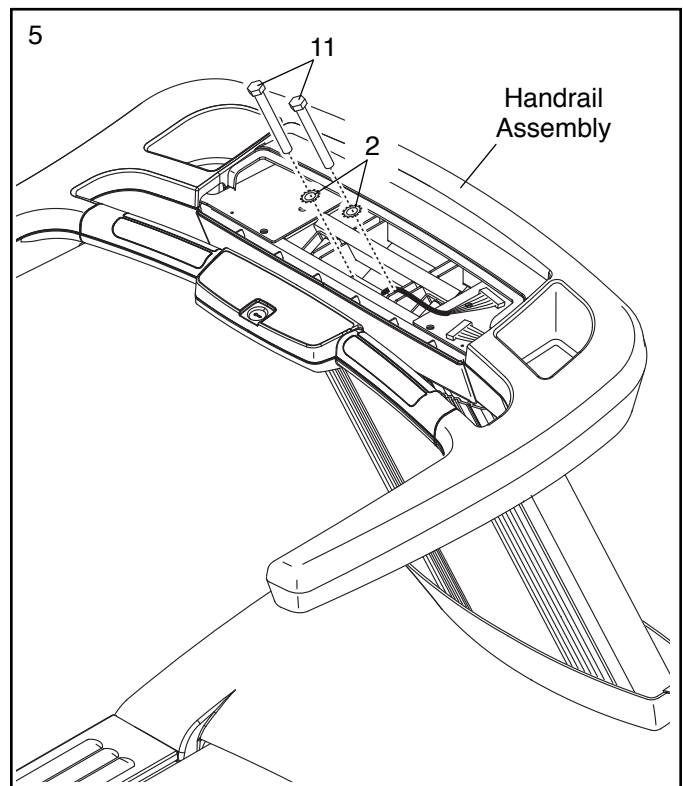

6. Tighten two 3/8" x 3 3/4" Screws (11) with two 3/8" Flat Washers (43) into the handrail assembly. **Start both Screws, and then tighten them.**

**See step 5. Tighten the two 3/8" x 3 3/4" Screws (11).**

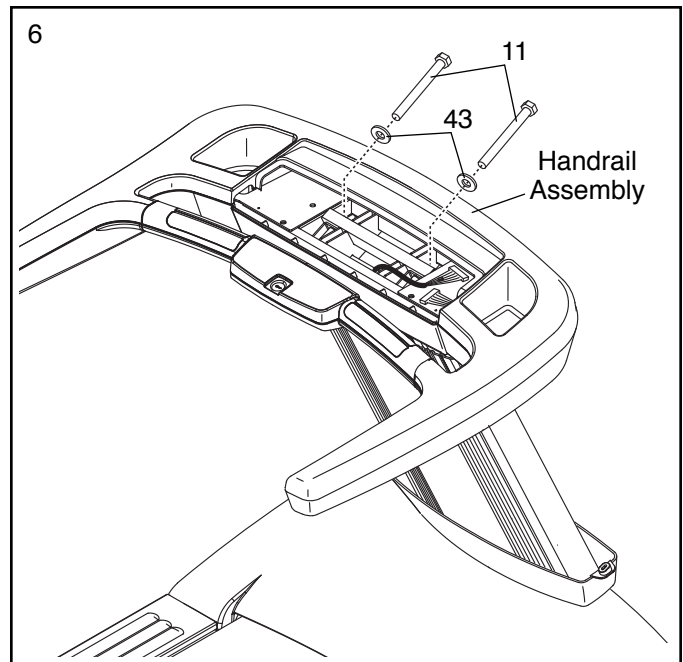

7. Have a second person hold the Console Assembly (101) near the handrail assembly.

**See the inset drawing.** Connect the Upright Wire (111) and the handrail wire to the console wires. Make sure that the console wire and the handrail wire that you are connecting have connectors that are the same size. **The connectors should slide together easily and snap into place.** If they do not, turn one connector and then try again. **IF THE CONNECTORS ARE NOT CONNECTED PROPERLY, THE CONSOLE MAY BE DAMAGED WHEN THE POWER IS TURNED ON.**

Next, insert the excess wires downward into the Upright Cover (80).

Then, set the Console Assembly (101) on the handrail assembly. **Make sure not to pinch any wires.**

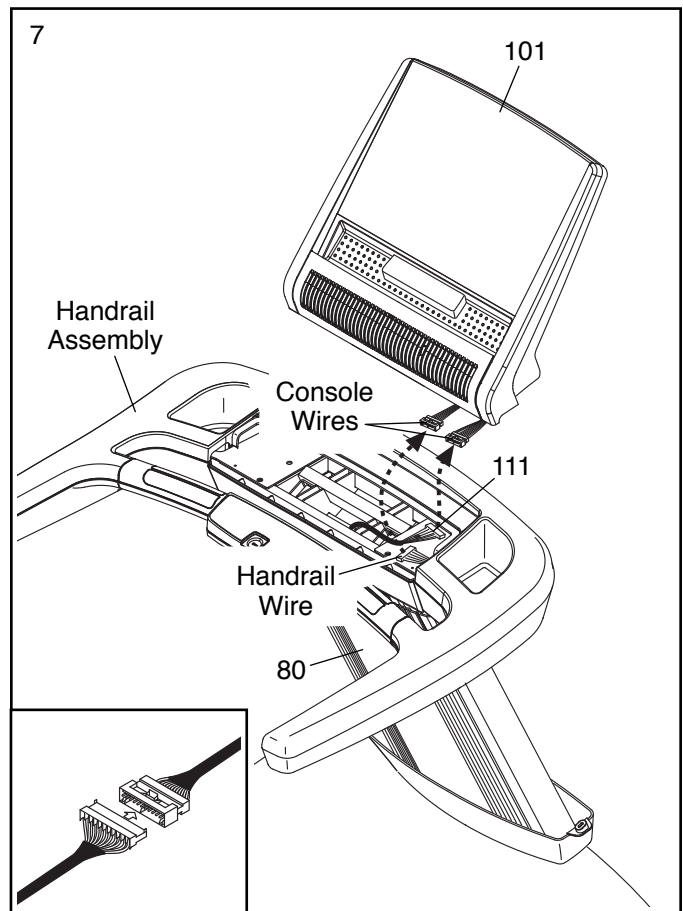

8. Tighten four 3/8" x 2 3/4" Screws (27) with two 3/8" Star Washers (2) into the handrail assembly.

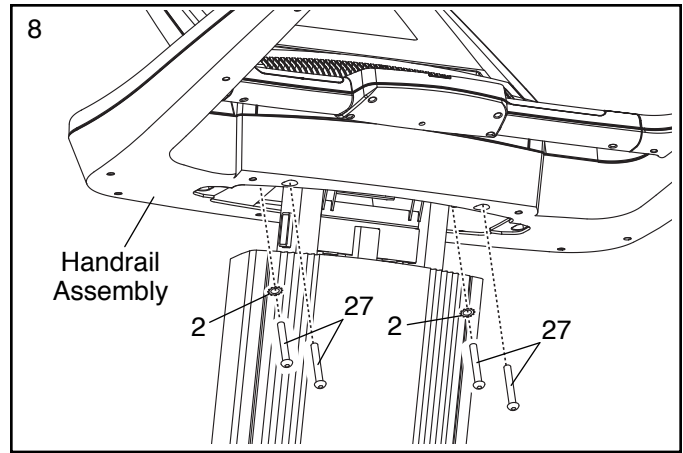

9. Attach the Upright Collar (105) to the handrail assembly with two #8 x 5/8" Screws (18).

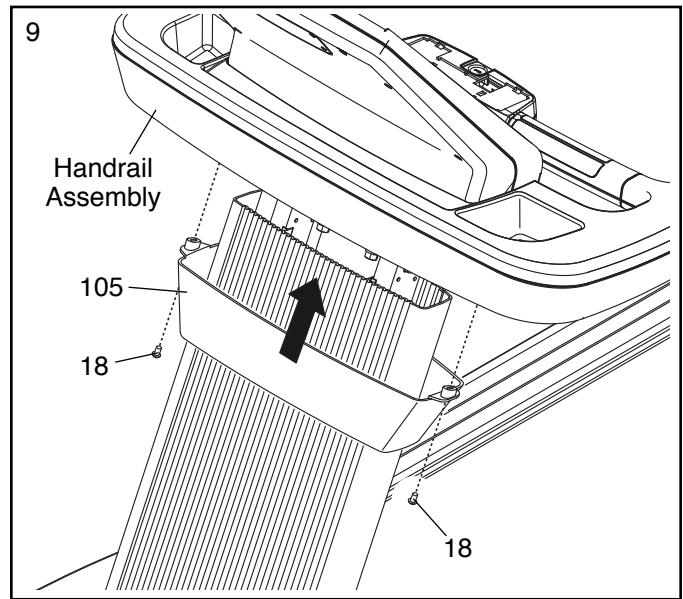

10. With the help of second person, carefully tip the treadmill onto one side. Remove any packing materials from the bottom of the Frame (53).

Next, attach the two Rear Foot Covers (91) to the Frame (53) with the four #8 x 3/4" Tek Screws (28).

Then, fully thread the two Leveling Feet (64) into the bottom of the Frame (53).

Carefully tip the treadmill back to the upright position.

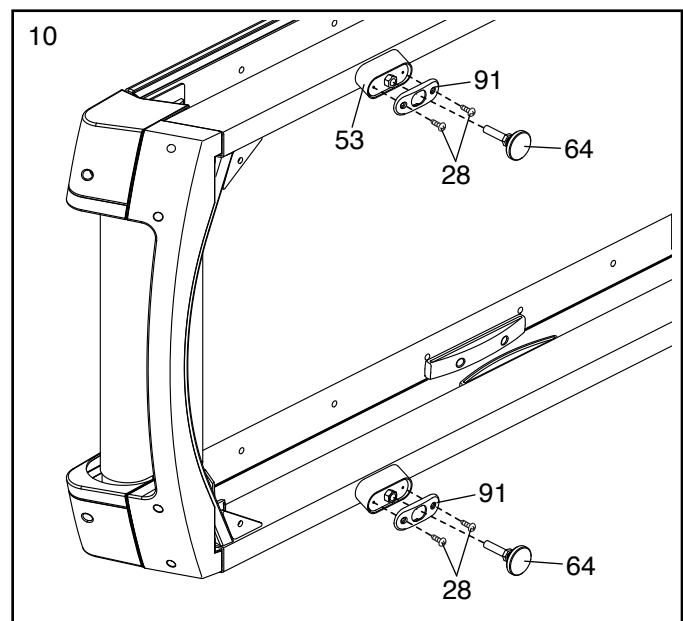

11. If necessary, move the treadmill to the desired location (see HOW TO MOVE THE TREADMILL on page 19).

After the treadmill is placed in the location where it will be used, make sure that the Leveling Feet (64) rest firmly on the floor. If the treadmill rocks even slightly, turn the nut on the Leveling Foot clockwise or counterclockwise until the rocking motion is eliminated.

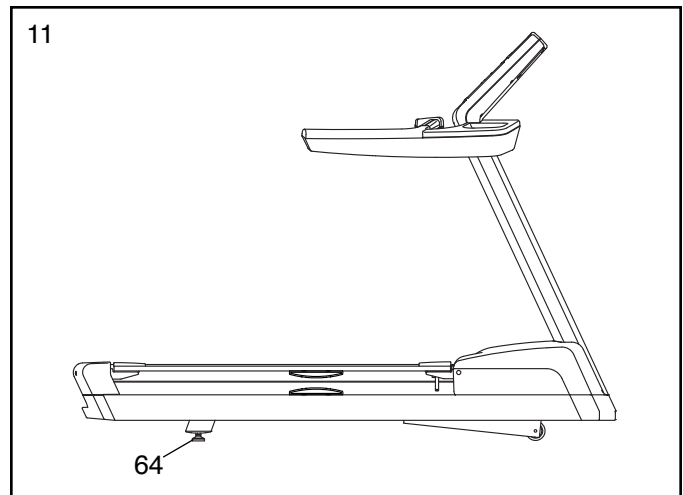

12. Cut the tie holding the Power Cord (70) to the Power Cord Cover (112).

Plug the Power Cord (70) into the treadmill. Attach the Power Cord Cover (112) with four #8 x 2" Screws (106).

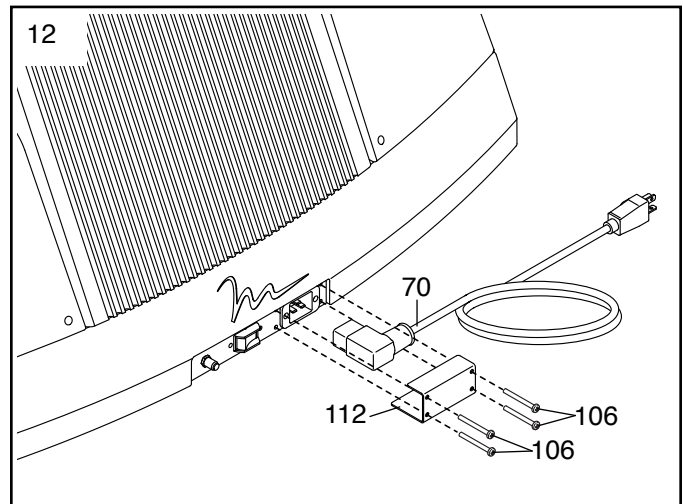

13. **Make sure that all parts are properly tightened before you use the treadmill.** If there are sheets of plastic on the treadmill decals, remove the plastic. To protect the floor or carpet, place a mat under the treadmill. To avoid damage to the console, keep the treadmill out of direct sunlight. Keep the included hex key in a secure place; the hex key is used to adjust the walking belt (see pages 25 and 26). Note: Extra hardware may be included.

# HOW TO USE THE TREADMILL

**⚠ DANGER:** Improper connection of the equipment-grounding conductor increases the risk of electric shock. Check with a qualified electrician or serviceman if you are unsure whether the product is properly grounded. Do not modify the plug—if it will not fit the outlet, have a proper outlet installed by a qualified electrician. Do not use an adapter to connect the plug to an improper receptacle.

## HOW TO CONNECT THE POWER CORD

**This product must be grounded.** If it should malfunction or break down, grounding provides a path of least resistance for electric current to reduce the risk of electric shock.

**This product is for use on a dedicated, 20-amp, 120-volt circuit. No other appliance should be on the same circuit.** This product has a cord with an equipment-grounding conductor and a grounding plug.

Plug the grounding plug into a standard NEMA 5-20 receptacle. Do not modify the plug or the receptacle. Do not use an adapter, a surge protector, or an extension cord. The receptacle must be grounded.

## WARRANTY INFORMATION

The warranty for this product does not cover damage or equipment failure caused by electric wiring not in compliance with electrical codes or the specifications in this manual, or failure to provide reasonable and necessary maintenance as outlined in this manual. Any failure or damage caused by unauthorized service; misuse; accident; negligence; improper assembly or installation; debris resulting from any destruction activities in the product's environment; rust or corrosion as a result of the product's location; alterations or modifications without written authorization; or failure on your part to use, operate, and maintain the product as set forth in this manual will void the warranty.

**All terms of the warranty are void if this product is moved beyond the continental borders of the United States of America (excluding Alaska, Hawaii, and Canada) and are then subject to the terms provided by that country's local authorized FreeMotion Fitness, Inc. representative.**

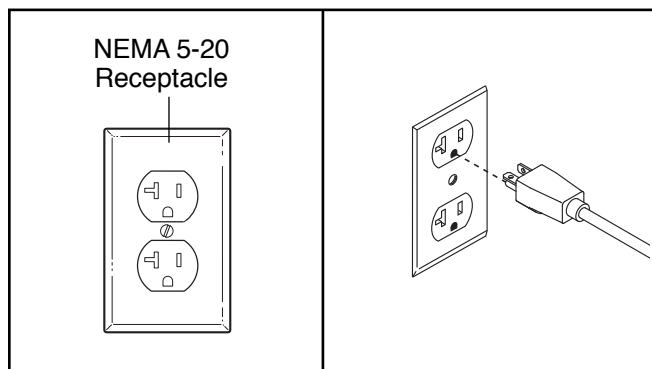

# HOW TO USE THE CONSOLE

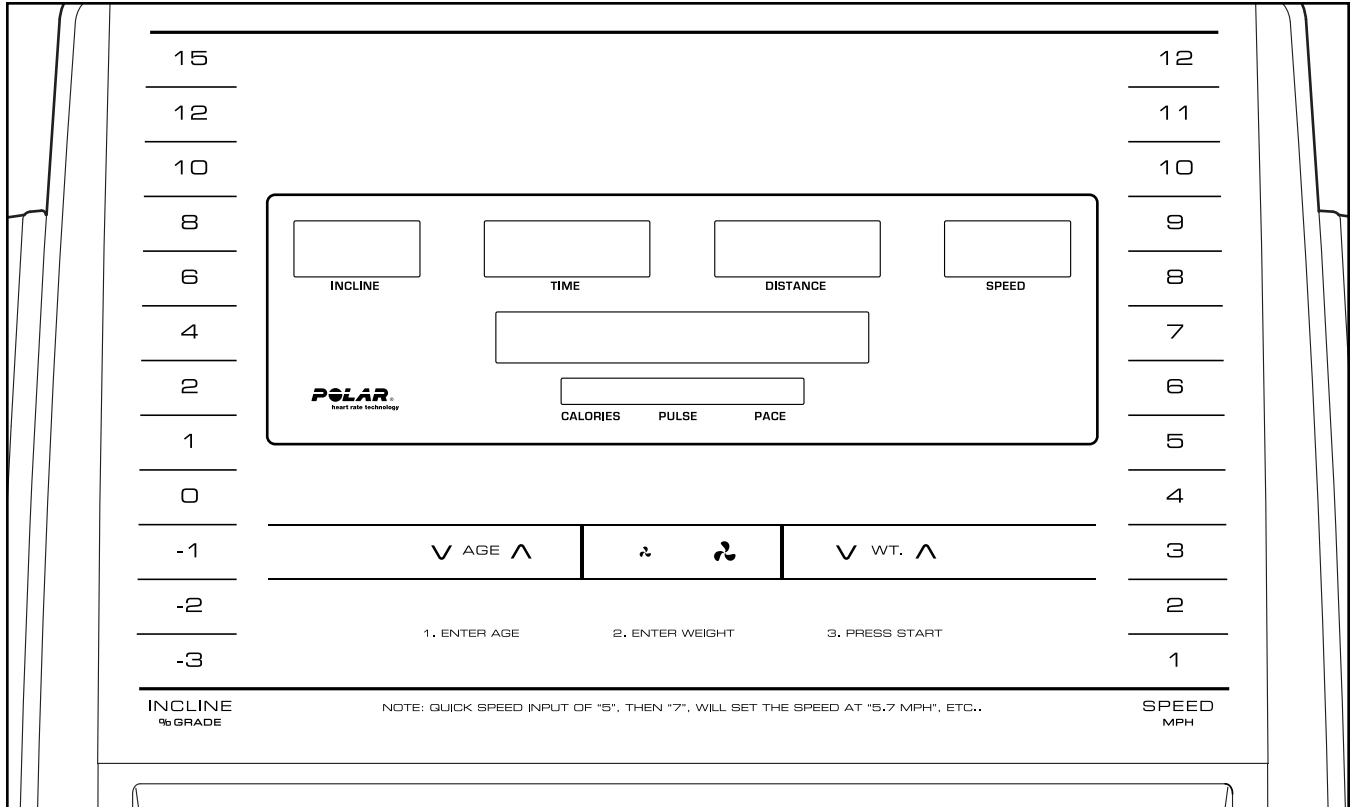

## FEATURES OF THE CONSOLE

The treadmill console offers an impressive array of features designed to make your workouts more effective and enjoyable. You can change the speed and incline of the treadmill with the touch of a button. As you exercise, the console will display instant exercise feedback. You can even measure your heart rate using the handgrip heart rate monitor.

**To turn on the power**, see page 16. **To use the manual mode**, see page 16. **To use the maintenance mode**, see page 18.

Note: The console can display speed and distance in either miles or kilometers. To find which unit of measurement is selected, see THE MAINTENANCE MODE on page 18. For simplicity, all instructions in this manual refer to miles.

**IMPORTANT: If there are sheets of plastic on the console, remove the plastic. To prevent damage to the walking platform, wear clean athletic shoes while using the treadmill. The first time you use the treadmill, observe the alignment of the walking belt, and center the walking belt if necessary (see page 26).**

## HOW TO TURN ON THE POWER

**IMPORTANT:** If the treadmill has been exposed to cold temperatures, allow it to warm to room temperature before turning on the power. If you do not do this, you may damage the console displays or other electrical components.

Plug in the power cord (see page 14). Next, locate the power switch on the treadmill frame near the power cord. Press the power switch into the on position.

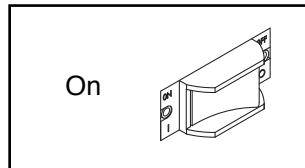

**IMPORTANT:** The console features a display demo mode, designed to be used if the treadmill is displayed in a store. If the displays light as soon as you plug in the power cord and press the power switch into the reset position, the demo mode is turned on. To turn off the demo mode, hold down the Stop button for a few seconds. If the displays remain lit, see THE MAINTENANCE MODE on page 18 to turn off the demo mode.

Next, stand on the foot rails of the treadmill. Find the clip attached to the key and slide the clip onto the waistband of your clothes. Then, insert the key into the console. After a moment, the displays will light. **IMPORTANT:** In an emergency, the key can be pulled from the console, causing the walking belt to slow to a stop. Test the clip by carefully taking a few steps backward; if the key is not pulled from the console, adjust the position of the clip.

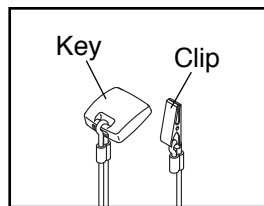

## HOW TO USE THE MANUAL MODE

### 1. Insert the key into the console.

See HOW TO TURN ON THE POWER at the left.

### 2. Enter your age and weight if desired.

To enter your age, press the Age increase and decrease buttons. To enter your weight, press the Wt. increase and decrease buttons.

### 3. Start the walking belt.

To start the walking belt, press the Start button, the Speed increase button, or one of the numbered Speed buttons.

If you press the Start button or the Speed increase button, the walking belt will begin to move at 1 mph. As you exercise, change the speed of the walking belt as desired by pressing the Speed increase and decrease buttons. Each time you press one of the buttons, the speed setting will change by 0.1 mph; if you hold down the button, the speed setting will change in increments of 0.5 mph. Note: After you press the button, it may take a moment for the walking belt to reach the selected speed setting.

If you press one of the numbered Speed buttons, the walking belt will gradually change speed until it reaches the selected speed setting. To select a speed setting that includes a decimal—such as 3.5 mph—press two numbered buttons in succession. For example, to select a speed setting of 3.5 mph, press the 3 button and then immediately press the 5 button.

To stop the walking belt, press the Stop button. The time will begin to flash in the display. To restart the walking belt, press the Start button or the Speed increase button.

### 4. Change the incline of the treadmill as desired.

To change the incline of the treadmill, press the Incline increase or decrease button or one of the numbered Incline buttons. Each time you press one of the buttons, the treadmill will gradually adjust to the selected incline setting.



## 5. Follow your progress with the displays.

### The matrix—

The matrix will display a track that represents 1/4 mile (400 meters). As you exercise, the indicators around the track will appear in succession until the entire track appears. The track will then disappear and the indicators will again begin to appear in succession.

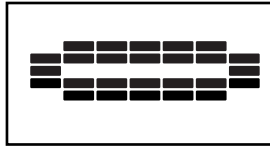

**The Incline display**—This display will show the incline of the treadmill.

**The Time display**—This display will show the elapsed time.

**The Distance display**—This display will show the distance that you have walked or run.

**The Speed display**—This display will show the speed of the walking belt.

**The Calories display**—This display will show the approximate number of calories you have burned.

**The Pulse display**—This display will show your heart rate when you use the handgrip pulse sensor (see step 6).

**The Pace display**—This display will show your pace.

To reset the displays, press the Stop button, remove the key, and then reinsert the key. Note: If the treadmill is not used for a few minutes, the displays will reset automatically.

## 6. Measure your heart rate if desired.

Before using the handgrip heart rate monitor, remove the sheets of plastic from the metal contacts on the pulse bar. In addition, make sure that your hands are clean.

To measure your heart rate, **stand on the foot rails** and hold the pulse bar with your palms on the metal contacts; **avoid moving your hands.**

When your pulse is detected, several dashes will appear and then your heart rate will be shown. **For the most accurate heart rate reading, continue to hold the contacts for about 15 seconds.**

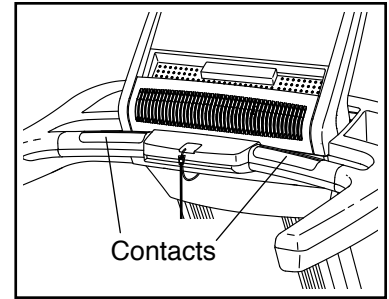

## 7. Turn on the fan if desired.

The fan features several speed settings and an auto mode. When the auto mode is selected, the speed of the fan will automatically increase and decrease as the speed of the walking belt increases and decreases.



Press the fan increase or decrease button to select a fan speed or to turn off the fan. Note: If the fan is on when the walking belt is stopped, the fan will turn off automatically after a few minutes.

## 8. Step onto the foot rails, press the Stop button, and adjust the incline of the treadmill to zero.

## THE MAINTENANCE MODE

The console features a maintenance mode that keeps track of treadmill information and allows you to personalize console settings.

To select the maintenance mode, hold down the Stop button while inserting the key into the console, and then release the Stop button. When the maintenance mode is selected, press the Age increase and decrease buttons to access the optional screens. Then, press the Wt. increase and decrease buttons to change settings.

**UNITS**—This display will show which unit of measurement is selected. To view distance in miles, select UNITS ENGLISH. To view distance in kilometers, select UNITS METRIC.

**PAUSE TIME**—This display allows you to adjust the amount of time that will pass before the console will reset the displays after the walking belt has been paused.

**IDLE TIME**—This display allows you to adjust the amount of time that will pass before the console goes to sleep after no buttons have been pressed.

**TOT TIME**—This display will show the total number of hours that the treadmill has been used.

**TOT DIST**—This display will show the total number of miles or kilometers that have been run on the machine.

**BELT DIST**—This display will show the total number of miles or kilometers that the walking belt has moved.

**RESET BELT**—This display is used to reset the belt distance after the walking belt is changed.

**CONTRAST**—This display allows you to adjust the contrast level of the console.

**CALIBRATE INCL**—This display is used to calibrate the incline system. To calibrate the incline system, press the Wt. increase and decrease buttons.

Note: There are several other optional screens in the maintenance mode meant to provide information about your machine to service technicians.

To exit the maintenance mode, remove the key from the console.

# HOW TO MOVE THE TREADMILL

Due to the size and weight of the treadmill, moving it requires two or three persons.

Before moving the treadmill, plug in the power cord and insert the key into the console (see HOW TO TURN ON THE POWER on page 16). Raise the incline to the highest position. Then, remove the key and unplug the power cord.

1. Hold the handle firmly in the location shown below. **CAUTION: To decrease the possibility of damage to the treadmill or of injury, do not lift the treadmill by the handrail.** Raise the handle until the treadmill rolls freely on the wheels. Then, carefully roll the treadmill to the desired location, and lower it to the level position. **CAUTION: To reduce the risk of injury, use extreme caution while moving the treadmill. Do not attempt to move the treadmill over uneven surfaces.**

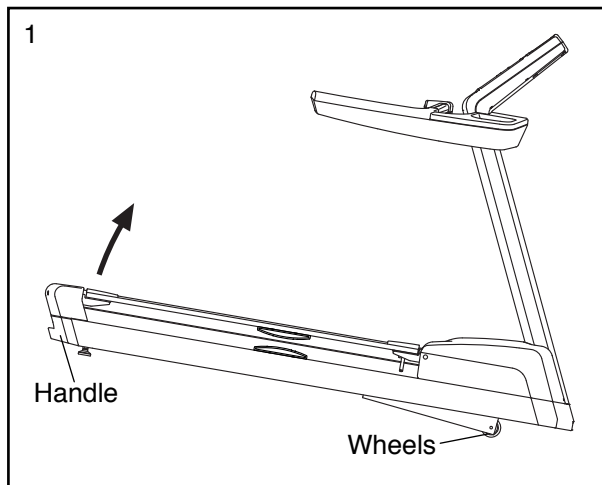

2. After the treadmill is placed in the location where it will be used, make sure that the leveling feet rest firmly on the floor. If the treadmill rocks even slightly, turn the nut on the leveling foot clockwise or counterclockwise until the rocking motion is eliminated.

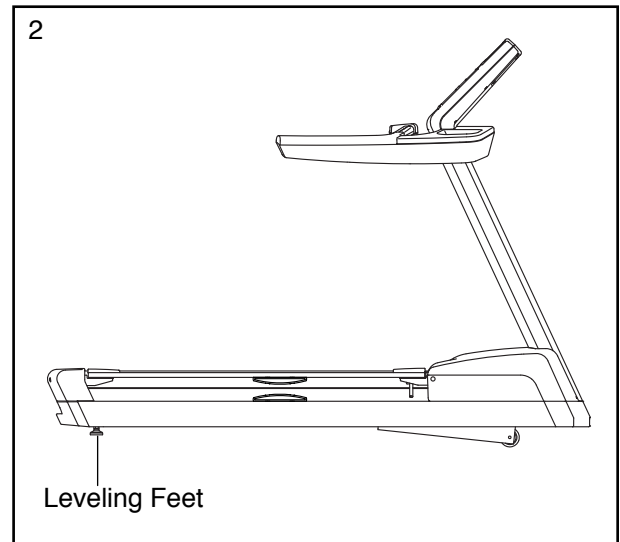

# PREVENTIVE MAINTENANCE

Regular maintenance is necessary for optimal performance and long life of the treadmill. Please read and follow all instructions below. **If the treadmill is not maintained as described, components may wear excessively, the treadmill may become damaged, and the warranty will be voided.** If you have questions about maintenance, see the back cover of this manual. **CAUTION: Make sure to remove the key and unplug the power cord before performing any maintenance procedures.**

## WEEKLY MAINTENANCE

1. **Unplug the power cord.** Inspect and properly tighten all external parts of the treadmill.
2. Apply a mild multi-purpose cleaner to a 100% cotton cloth and remove any dust and grime from the handrails, upright, foot rails, frame, and motor hood. In addition, wipe the walking platform along the sides of the walking belt. **Do not wipe under the walking belt.** Apply a small amount of mild multi-purpose cleaner to a 100% cotton cloth and wipe the console and the screen(s). **Do not spray cleaner directly onto the treadmill or use ammonia or acid-based cleaners.**
3. Make sure that the walking belt is centered and properly tightened. If it is centered and runs smoothly, do not make any adjustments. If the walking belt needs to be adjusted, see pages 23 and 26.

## MONTHLY MAINTENANCE

1. **Unplug the power cord.** Remove the four 5/16" x 1/2" Screws (16) attaching the Motor Hood (66), and lift off the Motor Hood.

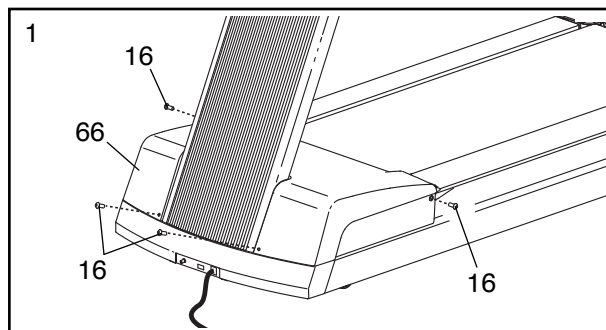

2. Using a handheld vacuum, clean the area under the Motor Hood (not shown). **Be careful to avoid touching any components.** Then, check the Motor Belt (57) for wear and cracks. If the Motor Belt needs to be replaced, see the back cover of this manual.

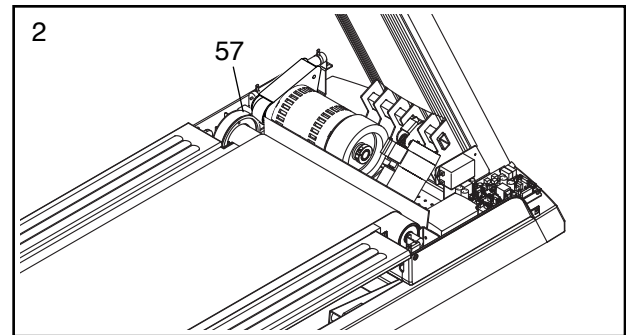

3. Plug in the power cord and insert the key into the console. Then, press the Start button. **Be careful to avoid injury; keep your hands away from moving parts and make sure that your clothes cannot become caught in moving parts.** While the walking belt is moving, check the treadmill for unusual noises or odors. If any of these problems exists, see the back cover of this manual.

**Remove the key and unplug the power cord. See step 1.** Reattach the Motor Hood (66) with the 5/16" x 1/2" Screws (16).

## REPLACING THE WALKING PLATFORM AND THE WALKING BELT

Inspect the walking platform periodically for wear. If there is any wood showing through the phenolic coating, or if the surface is damaged, the walking platform should be replaced. When the walking belt becomes worn, it should be replaced. The walking platform and the walking belt should be replaced after every 10,000 to 15,000 miles (16,000 to 24,000 kilometers). Follow the instructions below to replace the walking platform and/or the walking belt. **Make sure to keep track of which holes the screws go in.**

### 1. Remove the key and unplug the power cord.

Remove the four 5/16" x 1/2" Screws (16) and the Motor Hood (66).

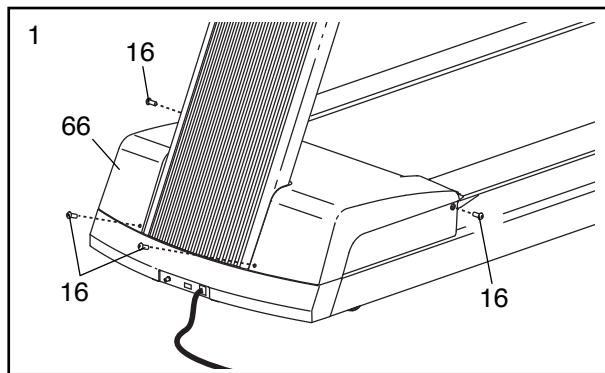

### 2. Remove the four indicated 1/4" x 3/4" Bolts (9) and the two M4 x 13mm Screws (138). Then, remove the Rear Cap (59).

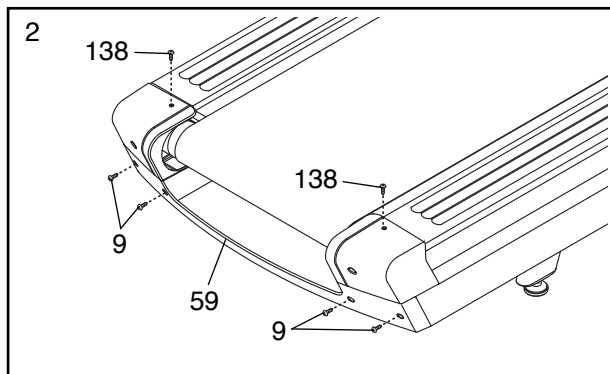

### 3. Remove the two 1/4" x 3/4" Bolts (9), the two 5/16" x 1 1/2" Bolts (8), the two 3/8" Washers (32), and the two 5/16" Locknuts (38).

Remove the two 3/8" x 2 1/2" Screws (7), the two 3/8" Lock Washers (not shown), and the two 3/8" Flat Washers (not shown).

Remove the 1/4" x 2 1/2" Screw (85) and the 1/4" Star Washer (89). Then, remove the Idler Roller (63) and the Drive Roller (113).

**If you are replacing the Walking Platform (44), go to step 4.**

**If you are replacing only the Walking Belt (46),** remove the Walking Belt and slide the new Walking Belt onto the Walking Platform (44). Then, follow steps 1–3 in reverse order. Turn both 3/8" x 2 1/2" Screws (7) clockwise four times only. **Go to step 5.**

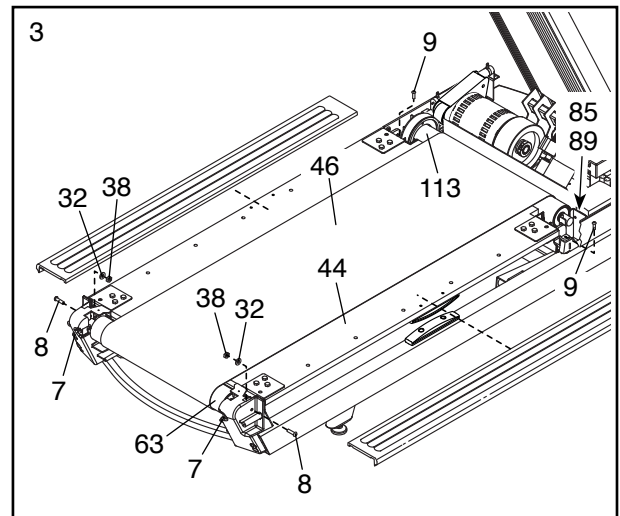

- Remove the Walking Belt (46) and the Walking Platform (44) from the treadmill. Next, remove the Walking Belt from the Walking Platform. Then, remove the twelve 3/8" x 1 1/2" Bolts (5) and the twelve 3/8" Locknuts (34), and slide the Rear and Front Platform Brackets (47, 48) off the Walking Platform. Remove and save the four #16 x 1 1/2" Screws (147) and the two Platform Cushions (146).

Slide the Rear and Front Platform Brackets (47, 48) onto the new Walking Platform (44).

Follow steps 1–4 in reverse order. If you are replacing the Walking Belt (46), use the new Walking Belt. Turn the 3/8" x 2 1/2" Screws (7) (see step 3) clockwise four times only. **Go to step 5.**

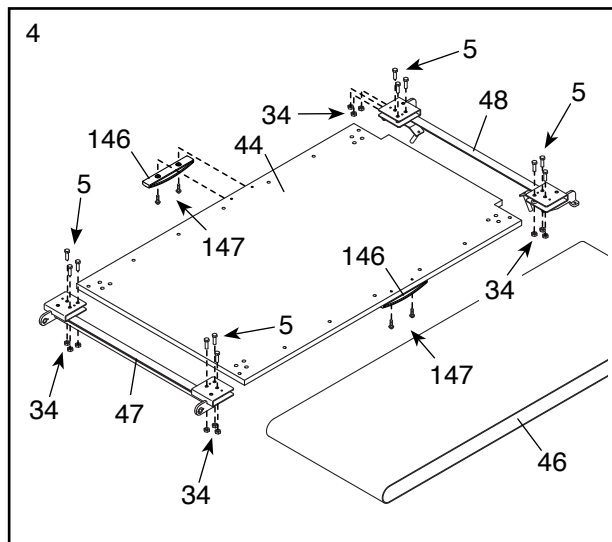

- The tension of the Walking Belt (46) now needs to be adjusted. Look under the right or left edge of the Walking Belt and find the small arrow printed on the Walking Belt; move the Walking Belt, if necessary, until you find the arrow. **Make sure that the arrow is pointing toward the rear of the treadmill, as shown.** If it is not, remove the Walking Belt, turn it around, and slide it back onto the Walking Platform (44). Do not tighten the Walking Belt yet.

Move the Walking Belt (46), if necessary, until the seam across the Walking Belt is underneath the Walking Platform (44).

Using the hex key, turn both idler roller screws counterclockwise, 1/4 of a turn. Tighten the Walking Belt (46) until the marks on both sides of the Walking Belt are exactly 36" apart.

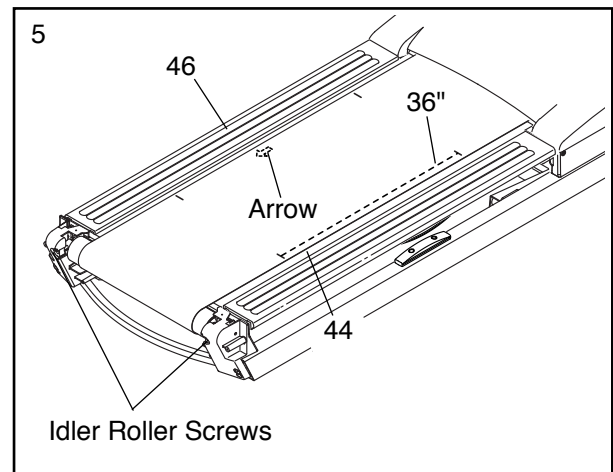

6. Center the Walking Belt (46) if necessary (see page 26). Then, plug in the power cord, step onto the foot rails, insert the key into the console, and press the Start button. Hold the handrails and gently press one foot against the moving Walking Belt. If the Walking Belt stops moving, **remove the key from the console, unplug the power cord,** and turn the two 3/8" x 2 1/2" Screws (7) clockwise one time. Continue to test the tension of the Walking Belt until the Walking Belt no longer slips. Make sure to keep the Walking Belt centered. **If the Idler Roller (63) stops moving, do not further tighten the Screws; please see the back cover of this manual.**

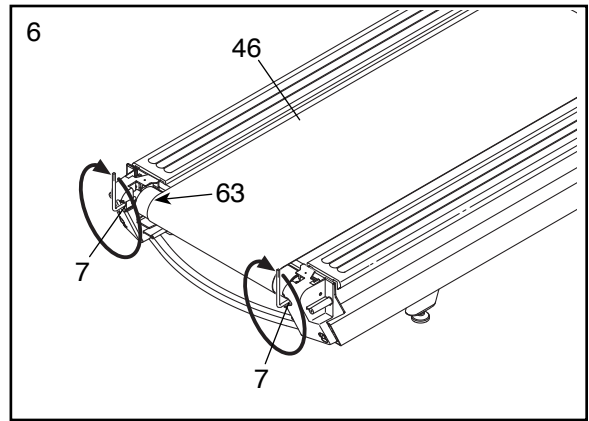

# SIX-MONTH PREVENTIVE MAINTENANCE RECORD

Photocopy this form and use it to record the preventive maintenance performed on the treadmill. Each copy of the form can be used for six months (26 weeks). When maintenance is performed, write the date in the appropriate spaces. **Make sure to perform each maintenance procedure as described on pages 20 to 23. If the procedures are not performed as described, components may wear excessively, the treadmill may become damaged, and the warranty will be voided.**

	Weekly Maintenance			Monthly Maintenance		
	Inspect and tighten all external parts of the treadmill.	Clean the treadmill.	Check the walking belt for proper tension and alignment.	Remove the motor hood and vacuum the motor compartment.	Check the motor belt for cracks and other wear.	Check the motor for arcing; check for noises or odors.
Week 1	/ /	/ /	/ /			
Week 2	/ /	/ /	/ /			
Week 3	/ /	/ /	/ /			
Week 4	/ /	/ /	/ /	/ /	/ /	/ /
Week 5	/ /	/ /	/ /			
Week 6	/ /	/ /	/ /			
Week 7	/ /	/ /	/ /			
Week 8	/ /	/ /	/ /	/ /	/ /	/ /
Week 9	/ /	/ /	/ /			
Week 10	/ /	/ /	/ /			
Week 11	/ /	/ /	/ /			
Week 12	/ /	/ /	/ /			
Week 13	/ /	/ /	/ /	/ /	/ /	/ /
Week 14	/ /	/ /	/ /			
Week 15	/ /	/ /	/ /			
Week 16	/ /	/ /	/ /			
Week 17	/ /	/ /	/ /	/ /	/ /	/ /
Week 18	/ /	/ /	/ /			
Week 19	/ /	/ /	/ /			
Week 20	/ /	/ /	/ /			
Week 21	/ /	/ /	/ /	/ /	/ /	/ /
Week 22	/ /	/ /	/ /			
Week 23	/ /	/ /	/ /			
Week 24	/ /	/ /	/ /			
Week 25	/ /	/ /	/ /			
Week 26	/ /	/ /	/ /	/ /	/ /	/ /

Walking Platform Replaced	/ /	/ /	Walking Belt Replaced	/ /
---------------------------	-----	-----	-----------------------	-----



---

# TROUBLESHOOTING

Most treadmill problems can be solved by following the simple steps below. Find the symptom that applies, and follow the steps listed. If further assistance is needed, see the back cover of this manual.

**SYMPTOM: The power does not turn on**

- a. Make sure that the power cord is plugged into a properly grounded outlet (see page 14).
- b. After the power cord has been plugged in, make sure that the key is inserted into the console.
- c. Check the power switch located on the treadmill near the power cord. Make sure that the power switch is pressed into the on position.

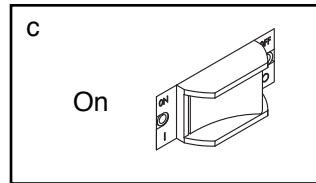

**SYMPTOM: The power turns off during use**

- a. Check the power switch (see the drawing c at the left). If the switch has tripped, wait for five minutes and then press the switch to the on position.
- b. Make sure that the power cord is plugged in. If the power cord is plugged in, unplug it, wait for five minutes, and then plug it back in.
- c. Remove the key from the console, and then reinsert it.
- d. If the treadmill still will not run, please see the back cover of this manual.

**SYMPTOM: The incline of the treadmill does not change correctly**

- a. Calibrate the incline system (see THE MAINTENANCE MODE on page 18).

**SYMPTOM: The walking belt is off-center or slips when walked on**

- a. **If the walking belt is off-center**, first remove the key and **UNPLUG THE POWER CORD**. **If the walking belt has shifted to the left**, use the hex key to turn the left idler roller screw clockwise 1/2 of a turn; **if the walking belt has shifted to the right**, turn the left idler roller screw counterclockwise 1/2 of a turn. Be careful not to overtighten the walking belt. Then, plug in the power cord, insert the key, and run the treadmill for a few minutes. Repeat until the walking belt is centered.

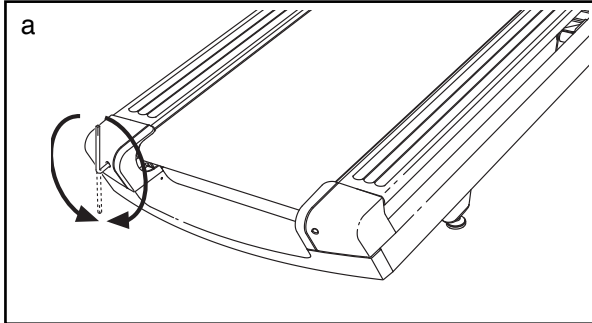

- b. **If the walking belt slips when walked on**, first remove the key and **UNPLUG THE POWER CORD**. Using the hex key, turn both idler roller screws clockwise, 1/4 of a turn. To properly tighten the treadmill, see step 5 on page 22. Be careful to keep the walking belt centered. Then, plug in the power cord, insert the key, and carefully walk on the treadmill for a few minutes. Repeat until the walking belt is properly tightened.

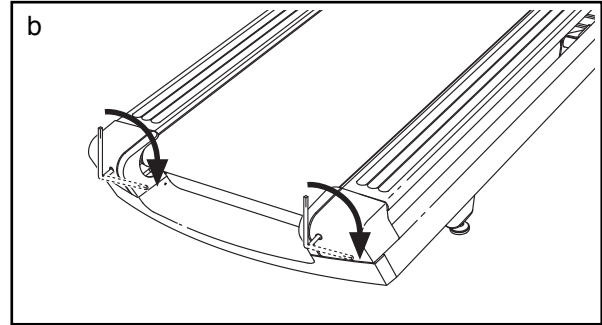

# EXERCISE GUIDELINES

**⚠ WARNING:** Before beginning this or any exercise program, consult your physician. This is especially important for persons over age 35 or persons with pre-existing health problems.

The heart rate monitor is not a medical device. Various factors may affect the accuracy of heart rate readings. The heart rate monitor is intended only as an exercise aid in determining heart rate trends in general.

These guidelines will help you to plan your exercise program. For detailed exercise information, obtain a reputable book or consult your physician. Remember, proper nutrition and adequate rest are essential for successful results.

## EXERCISE INTENSITY

Whether your goal is to burn fat or to strengthen your cardiovascular system, exercising at the proper intensity is the key to achieving results. You can use your heart rate as a guide to find the proper intensity level. The chart below shows recommended heart rates for fat burning and aerobic exercise.

165	155	145	140	130	125	115	♥♥
145	138	130	125	118	110	103	♥
125	120	115	110	105	95	90	♥
<hr/>							
20	30	40	50	60	70	80	

To find the proper intensity level, find your age at the bottom of the chart (ages are rounded off to the nearest ten years). The three numbers listed above your age define your “training zone.” The lowest number is the heart rate for fat burning, the middle number is the heart rate for maximum fat burning, and the highest number is the heart rate for aerobic exercise.

**Burning Fat**—To burn fat effectively, you must exercise at a low intensity level for a sustained period of time. During the first few minutes of exercise, your body uses carbohydrate calories for energy. Only after the first few minutes of exercise does your body begin to use stored fat calories for energy. If your goal is to burn fat, adjust the intensity of your exercise until your heart rate is near the lowest number in your training zone. For maximum fat burning, exercise with your heart rate near the middle number in your training zone.

**Aerobic Exercise**—If your goal is to strengthen your cardiovascular system, you must perform aerobic exercise, which is activity that requires large amounts of oxygen for prolonged periods of time. For aerobic exercise, adjust the intensity of your exercise until your heart rate is near the highest number in your training zone.

## WORKOUT GUIDELINES

**Warming Up**—Start with 5 to 10 minutes of stretching and light exercise. A warm-up increases your body temperature, heart rate, and circulation in preparation for exercise.

**Training Zone Exercise**—Exercise for 20 to 30 minutes with your heart rate in your training zone. (During the first few weeks of your exercise program, do not keep your heart rate in your training zone for longer than 20 minutes.) Breathe regularly and deeply as you exercise; never hold your breath.

**Cooling Down**—Finish with 5 to 10 minutes of stretching. Stretching increases the flexibility of your muscles and helps to prevent post-exercise problems.

## EXERCISE FREQUENCY

To maintain or improve your condition, complete three workouts each week, with at least one day of rest between workouts. After a few months of regular exercise, you may complete up to five workouts each week, if desired. Remember, the key to success is to make exercise a regular and enjoyable part of your everyday life.

## SUGGESTED STRETCHES

The correct form for several basic stretches is shown at the right. Move slowly as you stretch—never bounce.

### 1. Toe Touch Stretch

Stand with your knees bent slightly and slowly bend forward from your hips. Allow your back and shoulders to relax as you reach down toward your toes as far as possible. Hold for 15 counts, then relax. Repeat 3 times. Stretches: Hamstrings, back of knees and back.

### 2. Hamstring Stretch

Sit with one leg extended. Bring the sole of the opposite foot toward you and rest it against the inner thigh of your extended leg. Reach toward your toes as far as possible. Hold for 15 counts, then relax. Repeat 3 times for each leg. Stretches: Hamstrings, lower back and groin.

### 3. Calf/Achilles Stretch

With one leg in front of the other, reach forward and place your hands against a wall. Keep your back leg straight and your back foot flat on the floor. Bend your front leg, lean forward and move your hips toward the wall. Hold for 15 counts, then relax. Repeat 3 times for each leg. To cause further stretching of the achilles tendons, bend your back leg as well. Stretches: Calves, achilles tendons and ankles.

### 4. Quadriceps Stretch

With one hand against a wall for balance, reach back and grasp one foot with your other hand. Bring your heel as close to your buttocks as possible. Hold for 15 counts, then relax. Repeat 3 times for each leg. Stretches: Quadriceps and hip muscles.

### 5. Inner Thigh Stretch

Sit with the soles of your feet together and your knees outward. Pull your feet toward your groin area as far as possible. Hold for 15 counts, then relax. Repeat 3 times. Stretches: Quadriceps and hip muscles.

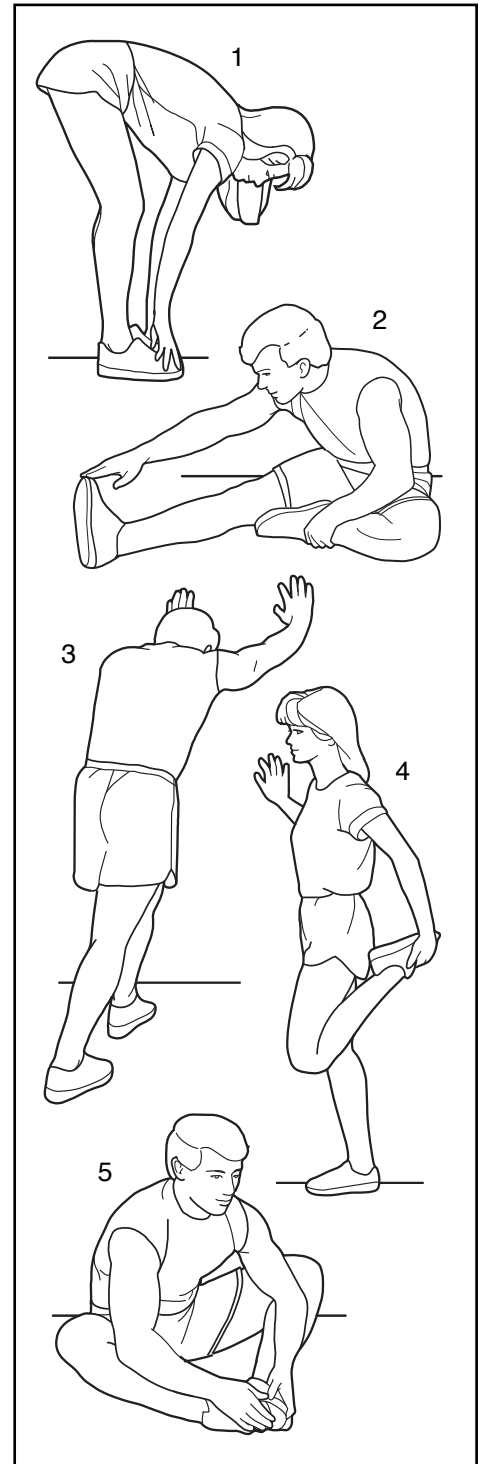

---

# NOTES

# PART LIST

Model No. FMTL39813.2 R0115A

Key No.	Qty.	Description	Key No.	Qty.	Description
1	6	3/8" x 3 1/4" Screw	51	1	Reed Switch
2	8	3/8" Star Washer	52	1	Controller
3	2	#8 x 5/8" Machine Screw	53	1	Frame
4	1	#8 x 3/4" Ground Screw	54	1	Drive Motor
5	12	3/8" x 1 1/2" Bolt	55	4	Motor Bushing
6	2	3/8" x 2 1/2" Bolt	56	1	Motor Mounting Plate
7	2	3/8" x 2 1/2" Screw	57	1	Motor Belt
8	6	5/16" x 1 1/2" Bolt	58	1	Left Rear Cap Insert
9	10	1/4" x 3/4" Bolt	59	1	Rear Cap
10	4	1/4" x 1" Screw	60	1	Left Cap Insert Bracket
11	4	3/8" x 3 3/4" Screw	61	1	Right Rear Cap Insert
12	2	1/4" x 1/2" Screw	62	2	Rear Platform Bracket Bearing
13	2	1/2" x 3 1/2" Screw	63	1	Idler Roller
14	1	1/2" x 1 5/8" Bolt	64	2	Leveling Foot
15	1	1/2" x 2 1/2" Bolt	65	1	Grommet
16	4	5/16" x 1/2" Screw	66	1	Motor Hood
17	5	#8 x 1/2" Tek Screw	67	1	Front Cap
18	10	#8 x 5/8" Screw	68	1	Electronics Bracket
19	6	#8 x 2" Screw	69	1	Power Switch
20	2	#6 x 3/8" Machine Screw	70	1	Power Cord
21	18	#8 x 1/2" Machine Screw	71	1	Receptical
22	2	#10 x 5/16" Machine Screw	72	1	Left Side Cover
23	5	#8 x 1/2" Washer Head Screw	73	1	Right Side Cover
24	18	#8 x 1/2" Screw	74	2	Hood Bracket
25	4	5/16" Standoff	75	1	Roller Cover
26	4	#8 x 5/8" Machine Screw	76	1	Incline Motor
27	4	3/8" x 2 3/4" Screw	77	2	Front Wheel
28	4	#8 x 3/4" Tek Screw	78	1	Lift Frame
29	4	#10 x 3/4" Screw	79	4	Lift Frame Spacer
30	4	#8 Star Washer	80	1	Upright Cover
31	12	#4 x 1/4" Screw	81	1	Upright
32	5	3/8" Washer	82	1	Bottom Handrail Cover
33	2	3/8" Lock Washer	83	1	Handrail Frame
34	14	3/8" Locknut	84	4	#10 Star Washer
35	2	1/2" Jam Nut	85	1	1/4" x 2 1/2" Screw
36	4	#10 x 1" Screw	86	1	Handrail Cover
37	2	Cap Clip	87	1	Pulse Assembly
38	2	5/16" Locknut	88	1	Pulse Bar Crossbar
39	4	5/16" Flat Washer	89	1	1/4" Star Washer
40	4	1/4" Nut	90	2	1/4" Jam Nut
41	1	Speed Disk	91	2	Rear Foot Cover
42	2	#8 Nut	92	1	Electronics Bracket
43	5	3/8" Flat Washer	93	1	Filter
44	1	Walking Platform	94	2	#6 x 1/4" Screw
45	2	Belt Guide	95	1	Converter Board
46	1	Walking Belt	96	12	Cable Tie
47	1	Rear Platform Bracket	97	1	Console Frame
48	1	Front Platform Bracket	98	1	Console Back
49	2	Platform Cushion	99	1	Access Door
50	1	Reed Switch Bracket	100	4	#4 x 3/8" Screw

Key No.	Qty.	Description	Key No.	Qty.	Description
101	1	Console Assembly	125	4	Platform Bracket Bushing
102	1	Rear Resistor Bracket	126	6	1/2" Standoff
103	1	Resistor	127	10	#8 x 3/4" Washer Head Screw
104	1	Front Resistor Bracket	128	2	Receptacle Bolt
105	1	Upright Collar	129	1	Right Cap Insert Bracket
106	4	#8 x 2" Screw	130	1	Fan Grill
107	1	Key/Clip	131	4	#6 x 1/4" Machine Screw
108	4	Wheel Bushing	132	1	Fan
109	4	Flat Wheel Bushing	133	1	Drive Roller Pulley
110	2	Lift Motor Washer	134	3	#10 x 1/4" Screw
111	1	Upright Wire	135	1	Drive Motor Pulley
112	1	Power Cord Cover	136	4	#6 Nut
113	1	Drive Roller	137	6	5/16" x 7/8" Screw
114	2	Footrail	138	2	M4 x 13mm Screw
115	2	1/2" Washer	139	1	3/8" x 4 1/2" Bolt
116	1	8" Wire Tie	140	2	3/8" x 2 3/8" Screw
117	1	Large Warning Decal	141	2	3/8" Nut
118	2	Wheel Axle	142	1	Idler Pulley
119	2	Caution Decal	143	1	Idler Arm
120	3	Voltage Warning Decal	144	2	Snap Ring
121	2	English Warning Decal	145	1	Idler Arm Pin
122	2	1/4" x 1/2" Bolt	146	4	Platform Cushion
123	2	#8 x 1/2" Small Machine Screw	147	4	#16 x 1 1/4" Screw
124	4	#8 x 3/4" Screw	*	-	User's Manual

Note: Specifications are subject to change without notice. For information about ordering replacement parts, see the back cover of this manual. \*These parts are not illustrated.

# EXPLODED DRAWING A

Model No. FMTL39813.2 R0115A

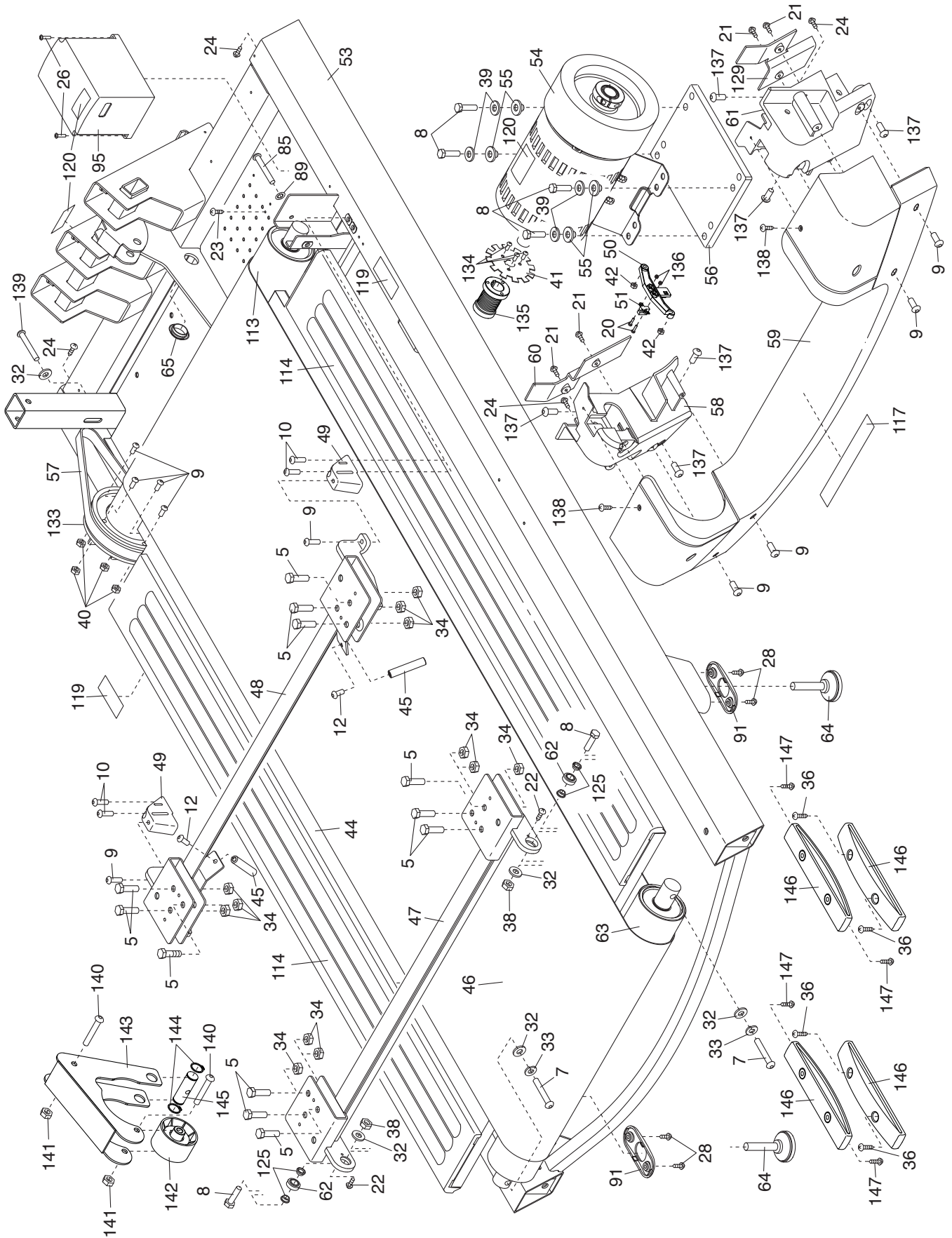



# EXPLODED DRAWING B

Model No. FMTL39813.2 R0115A

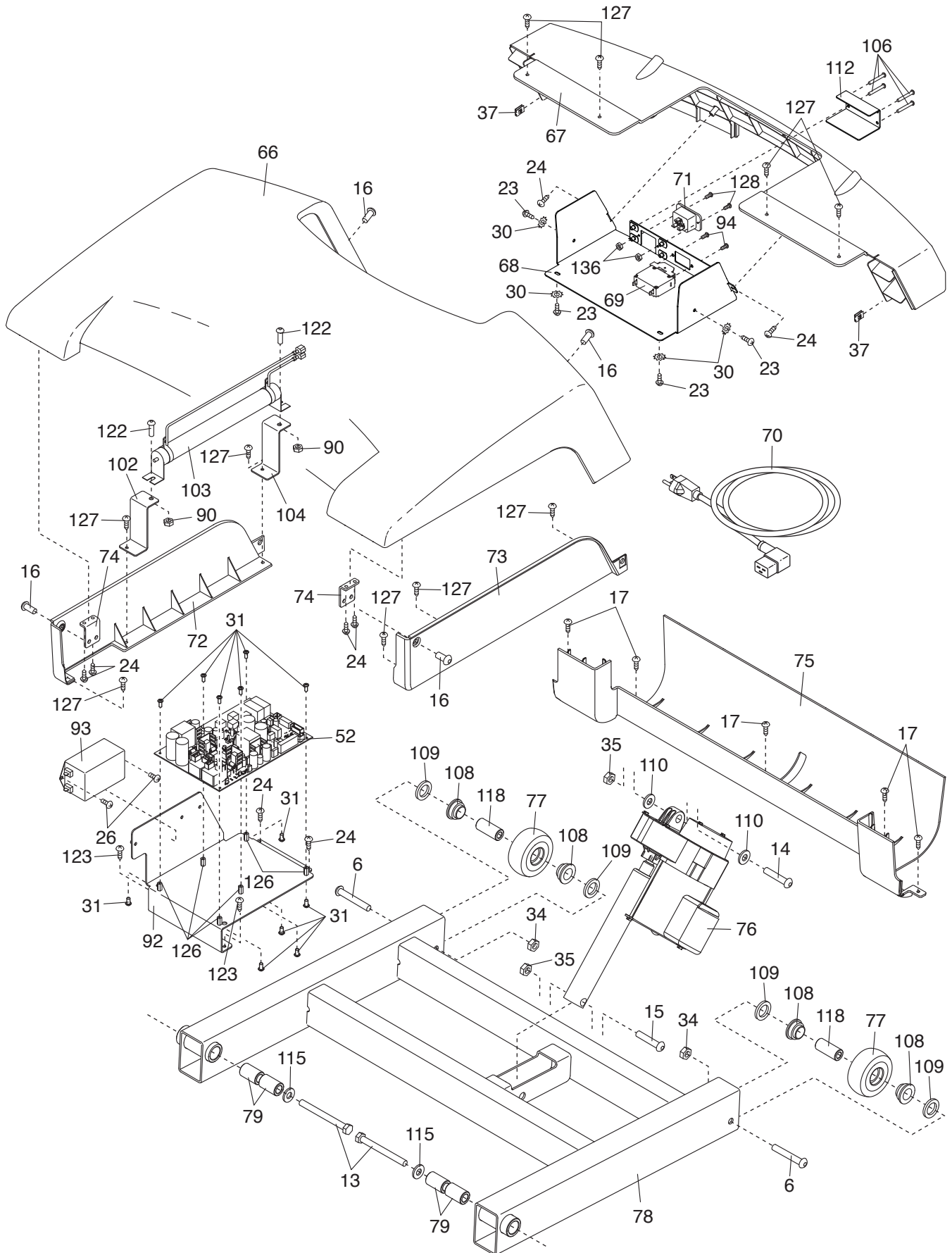

# EXPLODED DRAWING C

Model No. FMTL39813.2 R0115A

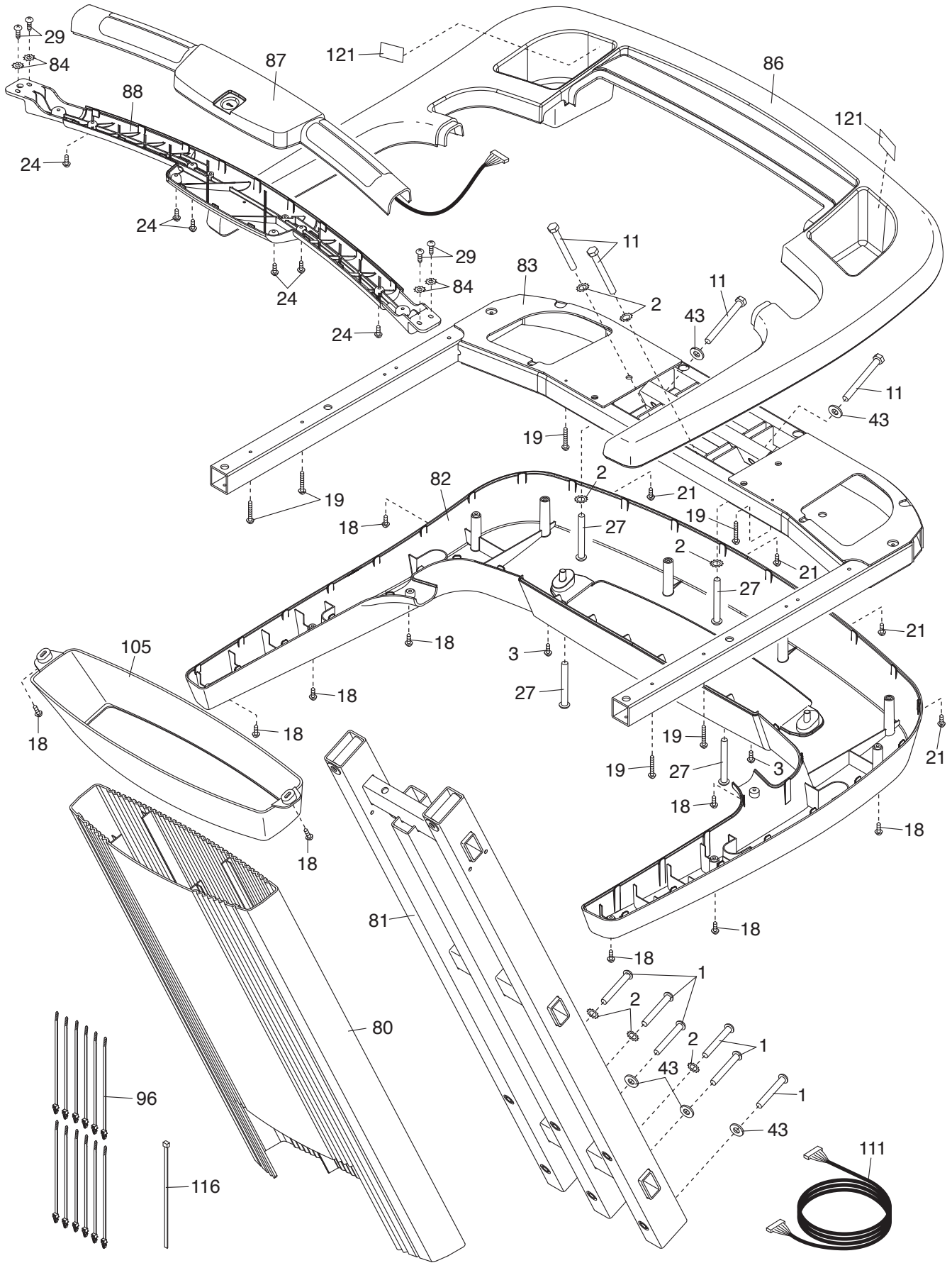

# EXPLODED DRAWING D

Model No. FMTL39813.2 R0115A

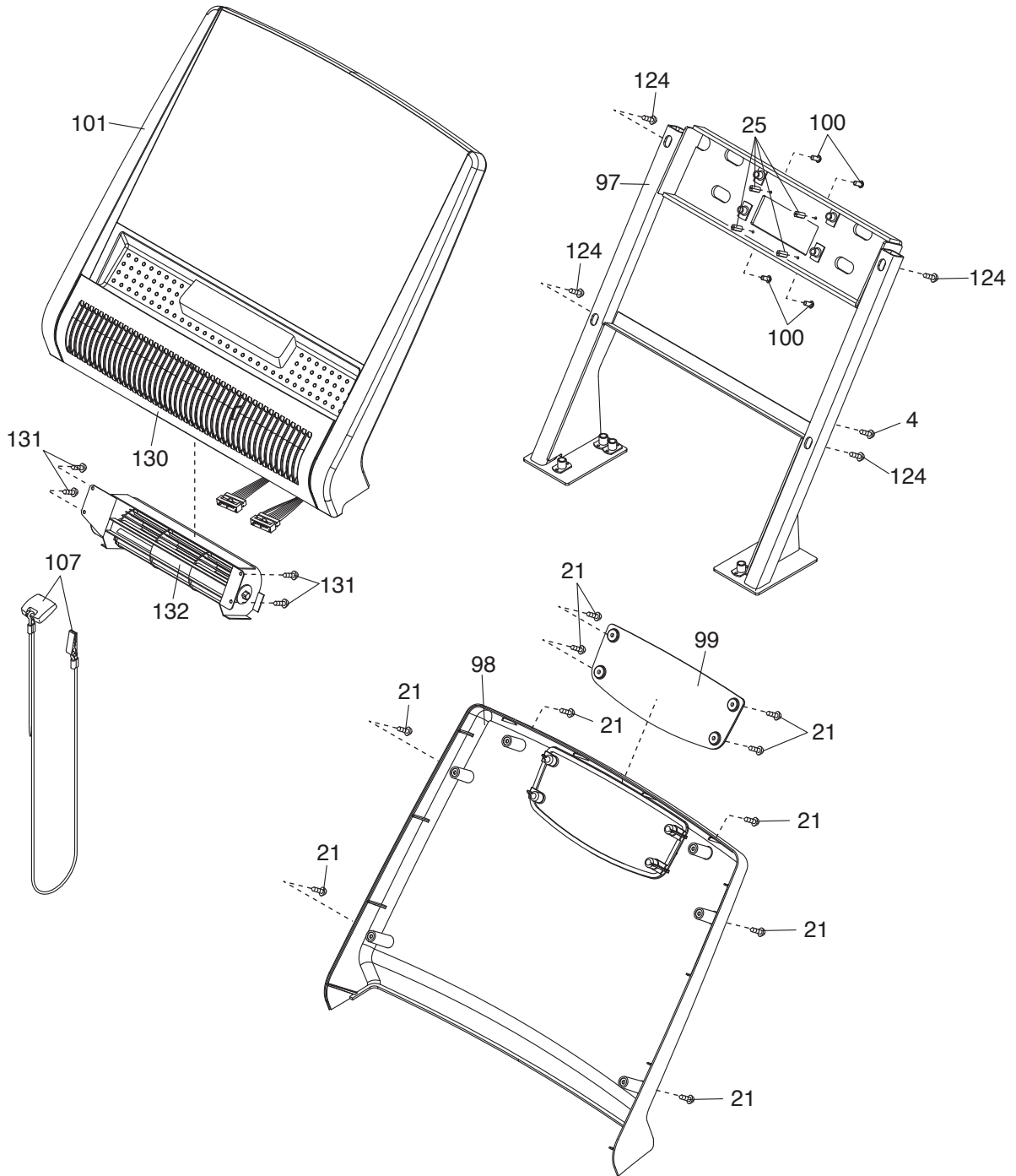

---

# HOW TO CONTACT CUSTOMER CARE

If you have questions after reading this manual, or if parts are damaged or missing, please contact Customer Care at one of the phone numbers or addresses listed below. **Please note the model number, serial number, and name of the product (see the front cover of this manual) before contacting Customer Care. If you are ordering replacement parts, please also note the key number and description of each part (see the PART LIST and the EXPLODED DRAWING near the end of this manual).**

## In the United States

Call: 1-800-201-2109 Mon.–Fri. 6 a.m.–6 p.m. MT

Email: [customercare@freemotionfitness.com](mailto:customercare@freemotionfitness.com)

Write:

FreeMotion Fitness

1500 South 1000 West

Logan, UT 84321-9813

United States

## Outside the United States

Call: 001-800-527-5417 or 001-435-786-3521

Mon.–Fri. 6 a.m.–3 p.m. USA Mountain Time

Email: [intlcustomercare@freemotionfitness.com](mailto:intlcustomercare@freemotionfitness.com)

---

## LIMITED WARRANTY

### WARRANTY PERIODS AND COVERAGE

FreeMotion Fitness warrants this product to be free from defects in workmanship and material under normal use and service conditions. Parts and labor are warranted for one (1) year, unless otherwise specified on the invoice.

The warranty period commences on the invoice date of purchase. Any parts repaired or replaced during this warranty period will be warranted for the remainder of the original warranty period.

### CONDITIONS AND LIMITATIONS

The following will void the warranty on this product:

1. This warranty applies only to the original owner and is non-transferable.
2. The labor warranty applies only to products sold in the US and Canada. Contact your authorized FreeMotion Fitness dealer for details on labor coverage in your country.
3. Any misuse, abuse, or improper service.
4. Users who weigh more than 400 lbs. (181 kg).
5. Damage caused by moving the product or improper storage including moving or storing the product on its side.
6. Use or storage of the product outdoors or in high-humidity environments including spa and pool areas.
7. Damage caused by improper wiring or insufficient electrical current. Note: This product may not have wiring.

This warranty shall not apply to the following:

1. Cosmetic items including grips, seats, decals, and labels.

2. Pick-up, delivery, or freight charges involved with a repair.
3. Any problem as a result of improper assembly or delivery.

### WHAT TO DO IF SERVICE IS REQUIRED

FreeMotion Fitness warranty service may be obtained by contacting the authorized dealer from which you purchased this product. Make sure to retain your original invoice and serial number information. If this product experiences a failure under the warranty terms set forth, FreeMotion Fitness shall provide at their option either repair, replacement, or refund of the purchase price. FreeMotion Fitness compensates service providers for warranty trips within their service area. You may be charged additionally for service calls beyond this service area.

FreeMotion Fitness is not responsible or liable for indirect, special, or consequential damages arising out of or in connection with the use or performance of the product; damages with respect to any economic loss, loss of property, loss of revenues or profits, loss of enjoyment or use, or cost of removal or installation; or other consequential damages. Some regions do not allow the exclusion or limitation of consequential damages. Accordingly, the above limitation may not apply to you. This warranty gives you specific rights, and you may have other rights that vary from region to region.

### TO CONTACT FREEMOTION FITNESS

See HOW TO CONTACT CUSTOMER CARE above.