

HOW TO CONTACT CUSTOMER CARE

If you have questions after reading this manual, or if you require assistance, please contact Customer Care at the address and phone number listed below. Please be prepared to give the following information:

- The MODEL NUMBER of the product (GZFM6004.3)
- The NAME of the product (FREEMOTION® ROW strength machine)
- The SERIAL NUMBER of the product (see the front cover of this manual)

When ordering replacement parts, please also give the KEY NUMBER and DESCRIPTION of the part(s) (see the PART LIST and the EXPLODED DRAWING on pages 12 and 13 of this manual).

Customer Care: 1-800-201-2109, Monday–Friday, 8 a.m.–5 p.m. Mountain Time
FreeMotion Fitness, Inc. • 1096 Elkton Drive, Suite 600 • Colorado Springs, CO 80907



Model No. GZFM6004.3

Serial No. _____

Write the serial number in the space above for future reference.

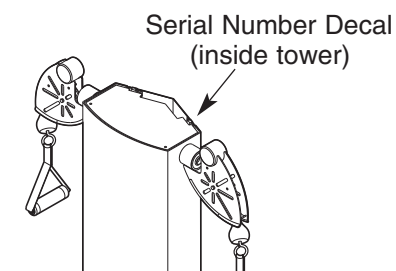

QUESTIONS?

At FreeMotion Fitness, we're committed to providing complete customer satisfaction. If you have questions, see HOW TO CONTACT CUSTOMER CARE on the back cover of this manual.

⚠ CAUTION

Read all precautions and instructions in this manual before using this equipment. Save this manual for future reference.

OWNER'S MANUAL

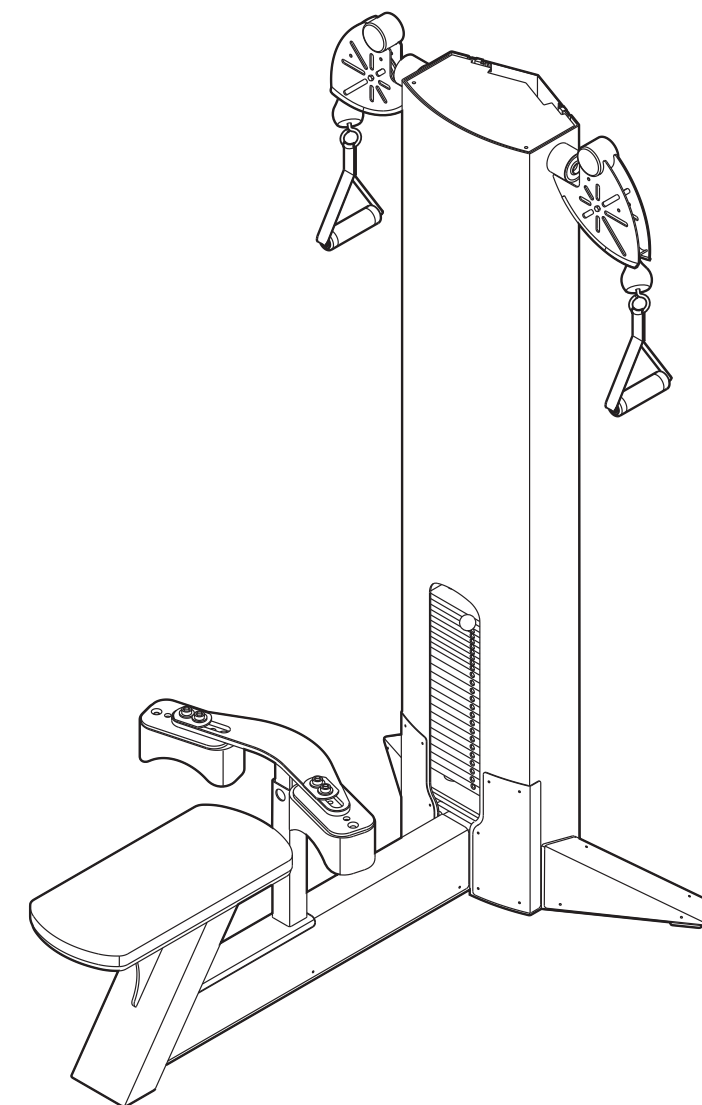

Visit our website at

www.freemotionfitness.com

TABLE OF CONTENTS

IMPORTANT PRECAUTIONS 3
WARNING DECAL PLACEMENT 4
BEFORE YOU BEGIN 5
ADJUSTMENTS 6
MAINTENANCE 7
CABLE DIAGRAM 11
PART LIST 12
EXPLODED DRAWING 13
HOW TO CONTACT CUSTOMER CARE Back Cover

NOTES

⚠ WARNING: To reduce the risk of serious injury, read the following important precautions before using the strength machine.

1. Read all instructions in this manual before using the strength machine. Use the strength machine only as described in this manual.
2. It is the purchaser's responsibility to ensure that there is enough space around the strength machine for the intended exercise. Do not crowd the strength machine.
3. Using the two 9/16" anchor holes to provide maximum stability, the strength machine must be anchored to the floor where required or whenever possible.
4. Use the strength machine only on a level surface. Cover the floor beneath the strength machine to protect the floor.
5. It is the responsibility of the owner to ensure that all users of the strength machine are adequately informed of all precautions, have read and understood all warning and caution labels, and are informed of how to use the strength machine properly.
6. Keep children under 12 and pets away from the strength machine at all times.
7. Keep hands and feet away from moving parts. Do not lean on or rest your hands on the strength machine when it is in use.
8. Always wear athletic shoes for foot protection while exercising.
9. All users of the strength machine should be instructed to report any injury or strength machine irregularity to facility staff immediately.
10. Make sure the weight pin is completely inserted into one of the weight plates.
11. Make sure the handles are attached securely before each use of the strength machine.
12. Check all cables, cable connections, and pulleys before each use of the strength machine. Make sure all parts are properly tightened. Replace any worn parts immediately.
13. Make sure the cable remains on the pulleys at all times. If the cable binds while you are exercising, stop immediately and make sure the cable is on the pulleys and nothing is interfering with the cable or pulleys.
14. The strength machine is designed to support a maximum user weight of 160 kg (350 lbs.).
15. If you feel pain or dizziness at any time while exercising, stop immediately and begin cooling down.

⚠ WARNING: Before beginning this or any exercise program, consult your physician. This is especially important for persons over the age of 35 or persons with pre-existing health problems. Read all instructions before using. ICON assumes no responsibility for personal injury or property damage sustained by or through the use of this product.

WARNING DECAL PLACEMENT

EXPLODED DRAWING—Model No. GZFM6004.3

R0305A

The decals shown below have been placed on the strength machine in the indicated locations. If a decal is missing or illegible, see HOW TO CONTACT CUSTOMER CARE on the back cover of this manual. Apply the decal in the location shown.

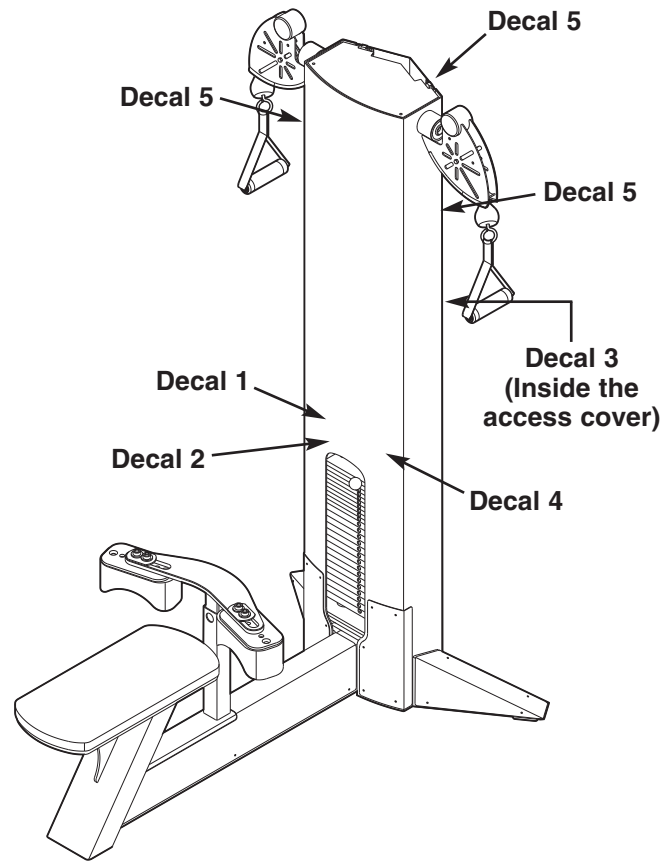

WARNING

- Obtain a medical exam before beginning an exercise program.
- Inspect the machine before use. Do not use if machine appears damaged or inoperable.
- Keep body and clothing free and clear of all moving parts.
- Be certain that the weight pin is completely inserted.
- NEVER pin the weight stack in an elevated position. NEVER use the machine if found in this condition.
- INSPECT all cables, straps and their connections. Do not use if any component is found to be worn or damaged.
- Do not use dumbbells or other means to incrementally increase the weight resistance, other than those provided by the manufacturer.
- Do not allow children on machines. Machine use by teenagers must be supervised by a knowledgeable adult.
- This equipment to be used only under qualified supervision.
- Do not remove this label. REPLACE IF DAMAGED.

Decal 1
Shown at 70%
PN GZ7003

CAUTION

KEEP AWAY FROM MOVING PARTS. FAILURE TO DO SO COULD RESULT IN PERSONAL INJURY.

7005-1199

Decal 2
Shown at 85%

CAUTION

Weight selector pin must be fully inserted into the weight plate.

Decal 4
PN GZ7026

WARNING

BACK PANEL MUST BE IN PLACE BEFORE MACHINE USE.

INSPECT ALL CABLES, STRAPS, MOVING PARTS, AND FASTENERS WEEKLY. REFER TO MAINTENANCE MANUAL.

KEEP HANDS FREE OF MOVING PARTS. FAILURE TO DO SO COULD RESULT IN PERSONAL INJURY.

7004-1199

Decal 3
Shown at 50%

WARNING

DO NOT USE MACHINE FROM THIS SIDE

Part # 7006

Decal 5

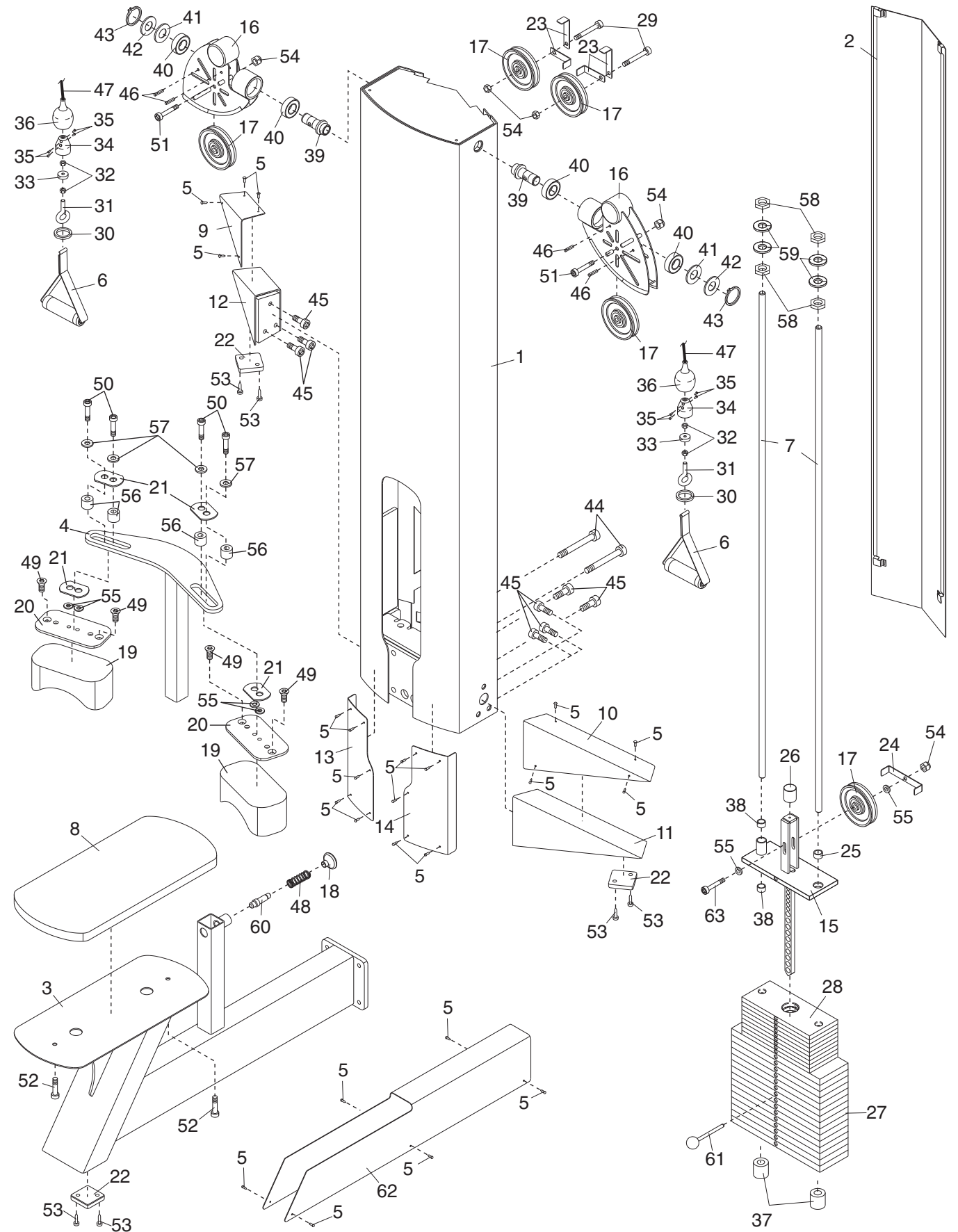

PART LIST—Model No. GZFM6004.3

R0305A

Key No.	Qty.	Description	Key No.	Qty.	Description
1	1	Tower	33	2	Cable Bearing
2	1	Access Cover	34	2	Aluminum Coupler
3	1	Seat Frame	35	8	Cable Set Screw
4	1	Thigh Bracket	36	2	Rubber Cover
5	24	Rivet	37	2	Weight Bumper
6	2	Handle	38	2	Small Weight Guide Bushing
7	2	Weight Guide	39	2	Trunnion
8	1	Seat	40	4	1" Bearing
9	1	Left Stabilizer Cover	41	2	1" Wave Washer
10	1	Right Stabilizer Cover	42	2	1" Washer
11	1	Right Stabilizer	43	2	1" Retainer Ring
12	1	Left Stabilizer	44	2	1/2" x 4 1/2" Bolt
13	1	Left Cover	45	8	1/2" x 1" Bolt
14	1	Right Cover	46	4	Roll Pin
15	1	Top Weight	47	1	Cable
16	2	Swivel Arm	48	1	Spring
17	5	Pulley	49	4	3/8" x 1" Flat Head Bolt
18	1	Adjustment Knob	50	4	3/8" x 1 1/4" Bolt
19	2	Thigh Pad	51	2	3/8" x 1 3/4" Bolt
20	2	Thigh Pad Plate	52	2	3/8" x 1" Bolt
21	4	Nylon Spacer	53	6	3/8" x 1/2" Screw
22	3	Floor Bumper	54	5	3/8" Nylon Locknut
23	4	Single Cable Guard	55	6	3/8" Serrated Lock Washer
24	1	Double Cable Guard	56	4	Spacer
25	1	Large Weight Guide Bushing	57	4	3/8" Washer
26	1	Top Weight Bumper	58	4	5/8" Nut
27	15	10-pound Weight	59	4	5/8" Lock Washer
28	9	5-pound Weight	60	1	Adjustment Pin
29	2	3/8" x 2" Bolt	61	1	Weight Pin
30	2	1 1/8" Retainer Ring	62	1	Seat Frame Cover
31	2	Eyebolt	63	1	3/8" x 2 1/4" Bolt
32	4	3/8" Jamnut	#	1	Owner's Manual

Note: "#" indicates a non-illustrated part. Specifications are subject to change without notice.

If replacement parts are needed, or if parts are missing or damaged, see HOW TO CONTACT CUSTOMER CARE on the back cover of the owner's manual.

BEFORE YOU BEGIN

Thank you for selecting the FREEMOTION® ROW strength machine. With unrestricted motion, you can work your body's muscle groups together—the same way you do in real life—and train more specifically and efficiently. Whether your goal is to tone your body, build dramatic muscle size and strength, improve your cardiovascular system, or train muscles for precise patterns of movement, the ROW strength machine will help you to achieve the specific results you want.

For your benefit, read this manual carefully before using the strength machine. If you have questions

after reading this manual, see HOW TO CONTACT CUSTOMER CARE on the back cover of this manual. To help us assist you, please note the product model number and serial number before calling. The model number is GZFM6004.3. The serial number can be found on a decal attached to the strength machine (see the front cover of this manual).

Before reading further, please review the drawing below and familiarize yourself with the parts that are labeled.

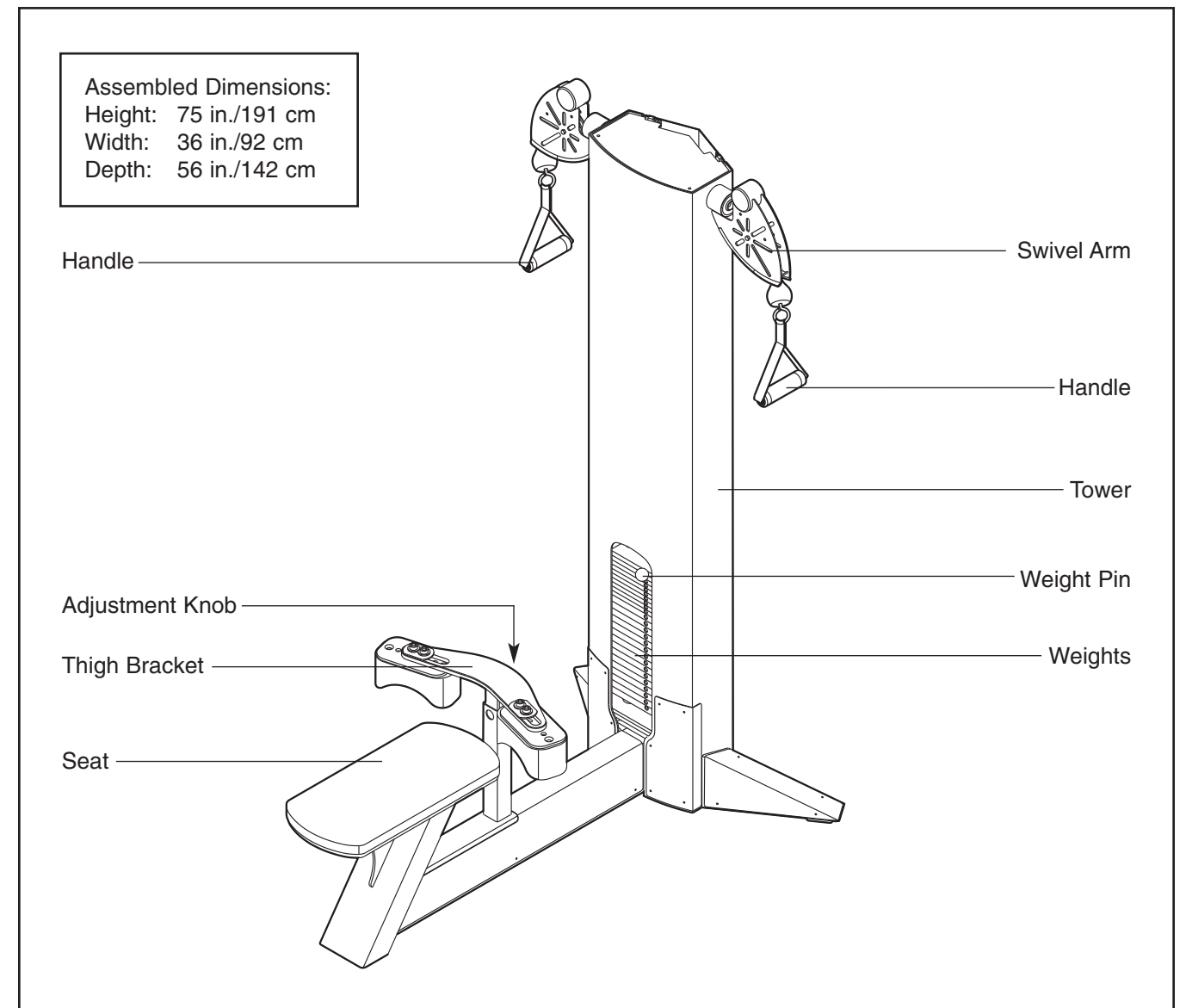

ADJUSTMENTS

This section explains how to adjust the strength machine. Make sure all parts are properly tightened each time the strength machine is used. Replace any worn parts immediately.

ADJUSTING THE RESISTANCE

To change the amount of resistance for your workout, insert the weight pin into the desired weight. Make sure that the weight pin is fully inserted into the weight stack.

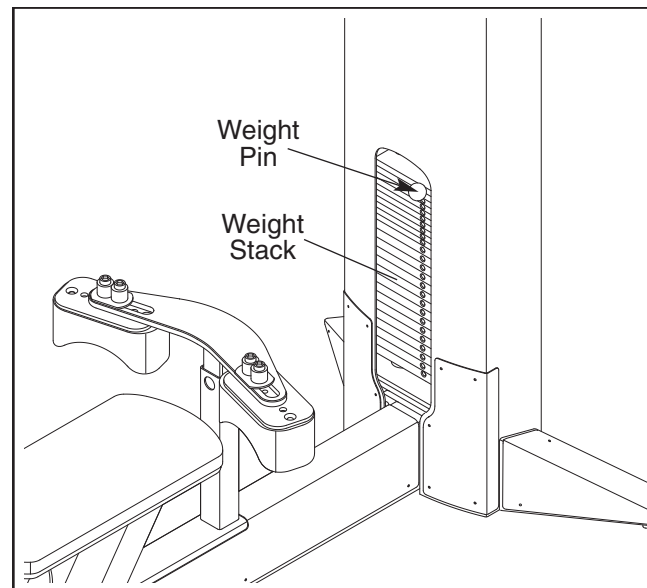

ADJUSTING THE THIGH PADS

To adjust the height of the thigh pads, pull the adjustment knob out as far as it will go. Slide the thigh bracket to the desired height and engage the adjustment knob into a hole in the thigh bracket.

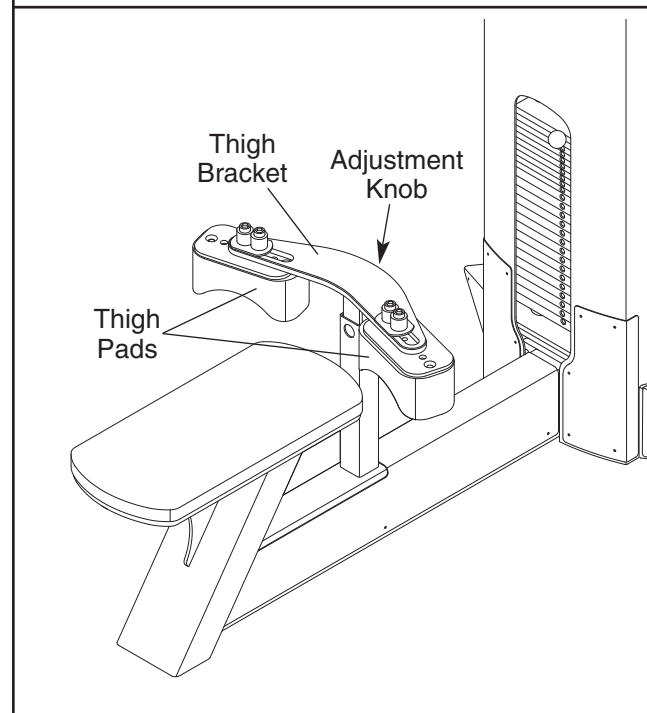

CABLE DIAGRAM

The cable diagram at the right shows the proper route of the cable. Use the diagram to make sure that the cable and the cable guards have been assembled correctly. If the cable has not been correctly routed, the strength machine will not function properly and damage may occur. The numbers show the correct route of the cable. **Make sure that the cable guards do not touch or bind the cable.**

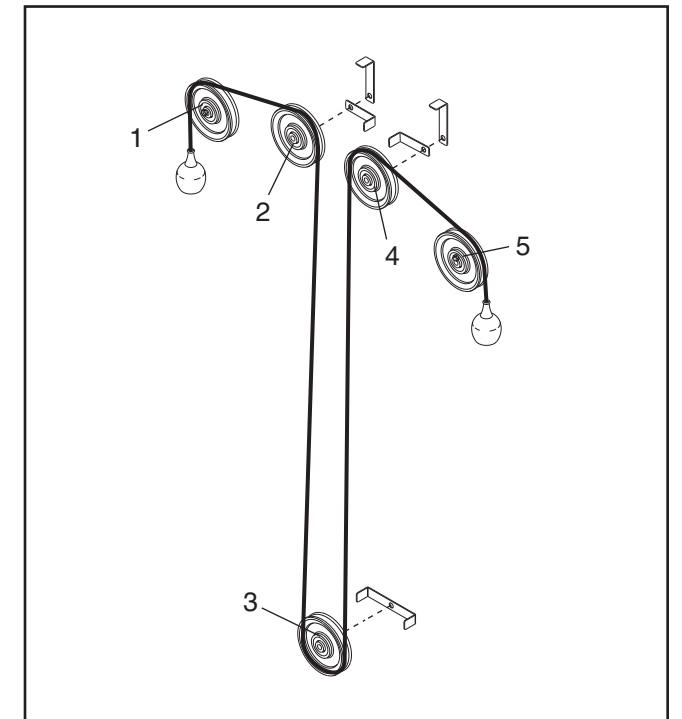

CABLE GUARDS

Periodically check the alignment of the cable guards to ensure that they are not dragging on the cable and that they are performing their intended function. If the cable guards are not aligned correctly, loosen the bolts slightly and adjust the cable guards as necessary.

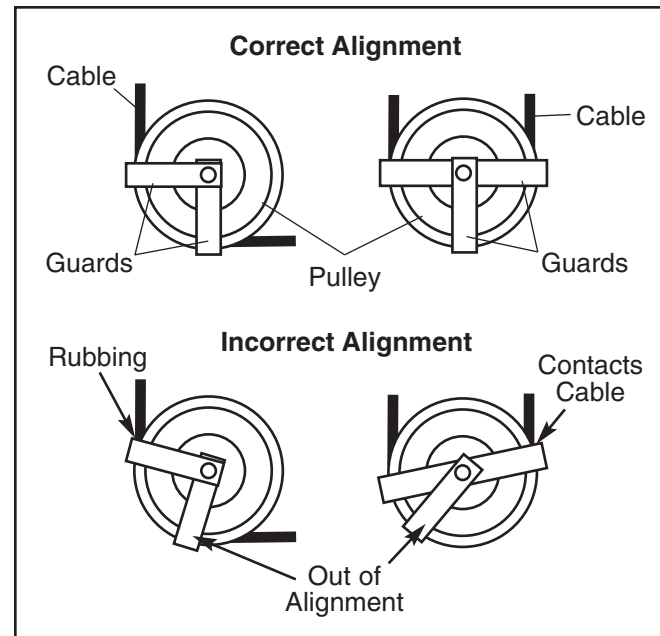

SERVICING THE WEIGHT STACK

For required parts, see HOW TO CONTACT CUSTOMER CARE on the back cover of this manual.

1. Remove the access cover by pulling it free at the bottom and then sliding it up until the two sets of tabs release.
2. Loosen the top bolt or nuts on each guide rod. Remove the bolts or nuts and let the guide rods slide down to the floor.
3. To remove the top weight, first unbolt the pulley(s) to release the cable using a 5/16" hex wrench and a 9/16" open-end wrench.
4. Slide the top weight off the top of the guide rods. Note: Pull the guide rods toward the back of the machine for increased clearance.

5. Servicing the weight stack involves replacing the three bushings in the top weight. First, use a punch to drive the three existing bushings out of the top weight.

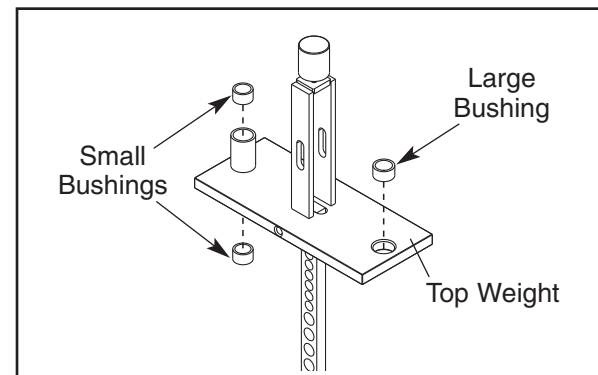

6. To insert the new bushings, hold each bushing square to the face of one of the holes in the top weight, place a protective piece of wood on top of the bushing, and lightly tap the bushing into place. The bushings should be flush with the surface. Note: There are two sizes of bushings. The slightly larger bushing is for the single hole in the top weight; the smaller bushings are for the top and bottom of the cylindrical standoff.
7. Clean and lubricate the guide rods by wiping them using a soft cloth containing automotive engine oil. Apply only a light coating over the entire length.
8. Replace the top weight on the guide rods. Bolt the pulley, cable, and cable guards back into place.
9. Reattach the guide rods to the top of the frame.
10. Insert the weight pin in the top weight. Pull the handle, lifting the top weight all of the way to the top. Slowly return the handle to the resting position. If the top weight sticks, loosen one of the guide rod bolts or nuts. Lift the top weight to the top again. Retighten the guide rod bolt or nuts. Check the full travel again and readjust the guide rods if necessary.
11. While slowly pulling the handle, have someone check the top weight pulley guard to ensure that it is not dragging or rubbing on the cable.
12. Replace the access cover.

MAINTENANCE

For safe and trouble-free operation of your FreeMotion Fitness® strength equipment, it is important to perform routine preventative maintenance on a regular basis. Make sure that all parts are properly tightened each time the strength machine is used. Replace any worn parts immediately. The strength machine can be cleaned with a damp cloth and a mild, non-abrasive detergent. Do not use solvents.

Note: Instruct all personnel to perform equipment inspection and maintenance requirements. Personnel must record and report any accident. For any questions or concerns, see HOW TO CONTACT CUSTOMER CARE on the back cover of this manual.

Use only original FreeMotion Fitness parts for repair or replacement to maintain your machine's warranty.

FreeMotion Fitness recommends the following procedures:

SCHEDULED MAINTENANCE

DAILY

1. Upholstery—General cleaning:

- Wipe using a soft cloth dampened with a light solution of household dish detergent and warm water.
- If necessary, use a soft bristle brush with the cleaning solution.
- Always remove the cleaning solution using a cloth dampened with clean water. Rinse often.

2. Upholstery—Difficult stains:

- Spray the stain with a non-abrasive household cleaner such as FORMULA 409® cleaner or a similar product.
- Rub the area gently and let it sit for a few minutes.
- Rinse thoroughly using a clean, water-dampened cloth.
- Repeat if necessary using a soft bristle brush.

Optional method for difficult stains:

- Rub the area gently using a soft cloth dampened with rubbing alcohol.
- Rinse thoroughly using a water-dampened cloth to remove alcohol residue.

CAUTION: When using any cleaning product, try it first in an inconspicuous place to ensure there is no damage to the material. Follow directions and adhere to the safety precautions of the manufacturer of each cleaning agent used. FreeMotion Fitness and its vendors cannot be held liable for damage or injuries resulting from the use or misuse of cleaning products.

3. Towers and Frames:

- Wipe with a light solution of mild soap and warm water. Rinse and dry thoroughly.

Important: Do not use abrasive cleaners, because they may scratch the equipment. Strong cleansers and abrasives will damage decals. Use caution around decals. Do not use solvents such as lacquer thinner, kerosene, gasoline, or similar liquids.

4. Stainless Steel Covers:

- Wipe with a light solution of mild soap and warm water. Rinse and dry thoroughly.
- If desired, or to remove corrosion, use available commercial stainless steel polishing compounds. Follow manufacturers' instructions.

5. Handles:

- Check all handle straps for wear.
- Visually check each strap along the full length for signs of wear such as cuts, tears, or nicks. Replace the strap immediately if necessary.
- A "fuzz" will appear on straps over time and is not a concern unless it appears to be worn through strands of the weave.

6. Straps with rings:

- If a ring is pulling through a strap or tearing away at the edge of the strap, replace the strap immediately.
- Check stitching points on straps for tears, worn spots, or separation. Replace the strap if necessary.

WEEKLY

1. Hardware:

- Check all nuts and bolts. Tighten them as required.

2. Cables:

- Check all cables for proper tension.
- Check the entire length of each cable by pulling each handle individually to its fully extended position and inspecting the cable that is exposed on the exterior of the machine, as well as the cable inside of the tower.
- Run your fingers along each cable, paying close attention to the bends and attachment points.
- Watch for the following conditions that may indicate a worn cable in need of replacement (see the drawings below):
 - A. Torn or split cable sheath that exposes the cable
 - B. Kinked or severely bent cable
 - C. Curled or twisted sheath
 - D. Stretched cable sheath, showing a thinning cross-section

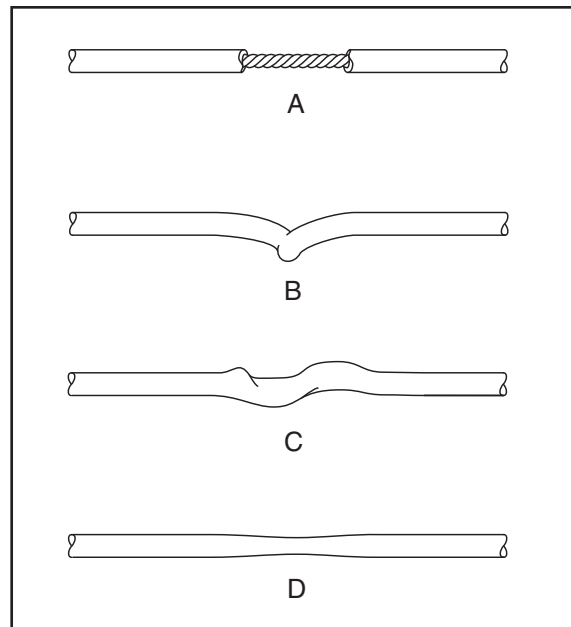

MONTHLY OR AS REQUIRED

1. Grips:

- Check all grips and replace them as needed.

2. Weight stack guide rods:

- Clean and lubricate the full length by wiping using a soft cloth containing automotive engine oil. Only a light coating over the entire length is needed.

CUSHION ATTACHMENT

Important: All FreeMotion Fitness® cushions are fabricated using dense plywood with tee-nuts installed for bolting to the machine framework. Because these tee-nuts are held by the plywood, they will not withstand the torque that standard nuts and bolts will. Therefore, when tightening the cushion bolts, turn them only until they are snug and the cushion does not move or feel loose. Overtightening may strip the tee-nuts from the plywood and make it impossible to remove the cushion in the future.

CABLE TENSION CHECK

1. Insert the weight pin into the top weight plate.
2. Slowly raise and lower the top weight by normal machine use. The top weight should come to rest just on top of the second weight when the handle is returned to the resting position.
 - If there is too much tension on the cable, the top weight will not rest on the second weight, and it may be difficult to insert the weight pin into the weight plates.
 - If there is not enough tension on the cable, the top weight will not be lifted immediately when one of the handles is pulled. Ideally, the handle/cable should not move more than 1.3 cm (1/2 in.) from the resting position before the top weight begins to be lifted.
3. If there is too much or not enough tension on the cable, adjust the cable as described in CABLE ADJUSTMENTS on page 9.

ADJUSTMENT KNOB

If an adjustment knob sticks, it will need to be relubricated. Disassemble the knob and apply a light coating of lithium grease. Reassemble the knob as shown in the diagram. If the adjustment knob still does not function properly, the spring may need to be replaced. To order a new spring, see HOW TO CONTACT CUSTOMER CARE on the back cover of this manual.

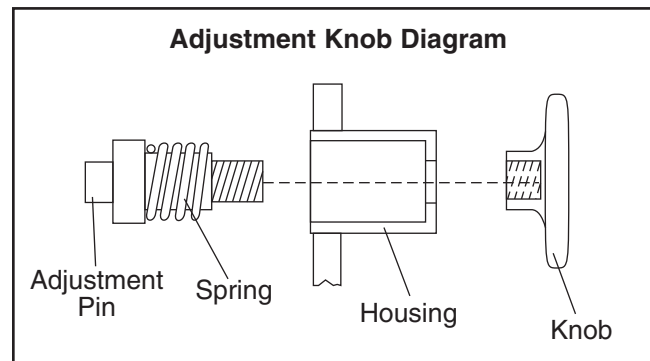

CABLE ADJUSTMENTS

CAUTION: After making any cable adjustment, pull the handle using a light load and have someone make sure that the cable is not derailed from a pulley or rubbing on a guard (see CABLE GUARDS on page 10).

INITIAL ADJUSTMENT

Top Weight Pulley Adjustment—All machines.

Tools required: 9/16" open or box-end wrench, 5/16" Allen wrench

Note: This is the primary adjustment for all machines. If this adjustment does not remove the excess slack, see ADDITIONAL ADJUSTMENTS at the right.

1. Remove the access cover by pulling it free at the bottom and then sliding it up until the two sets of tabs release.
2. Using a 5/16" Allen wrench and a 9/16" open or box-end wrench, loosen the nut holding the pulley in the bracket on the top weight.

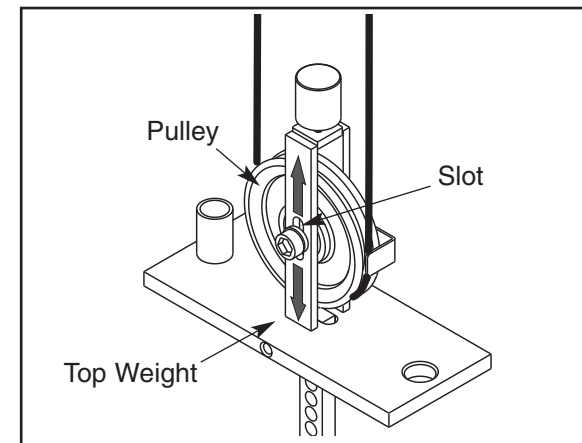

3. To increase the tension, slide the pulley down in the slot. To decrease the tension, slide the pulley up.
4. Tighten the nut and check the tension as described in CABLE TENSION CHECK on page 8. If necessary, readjust the pulley.
5. Replace the access cover.

ADDITIONAL ADJUSTMENTS

Handle End Adjustment—All machines with a strap and handle.

Tools required: 1/8" Allen wrench, cable cutters, utility knife, torque wrench

Note: Make this adjustment only if the pulley in the top weight has been fully adjusted to the bottom of the slot and the cable requires more tension.

Note: This adjustment is only for increasing the cable tension because it requires shortening the cable. Only one end of the cable should be shortened.

1. Create slack in the cable by removing the weight pin and pulling the handle out 15–20 cm (6–8 in.). Insert the weight pin into the third weight plate and the tube on the bottom of the top weight.
2. Push the black rubber cover off the aluminum coupler and slide the cover up the cable to contact the pulley in the swivel arm.
3. Loosen the four oval-point, 1/4-20-unc set screws in the coupler and pull the cable free.
4. Cut off 2.5 cm (1 in.) of the cable end using cable cutters. **Note: Using any other tool may flatten or disrupt the end strands so that it may be difficult to reinsert the cable into the hole of the coupler.**
5. Cut off 2.5 cm (1 in.) of the black cable sheath from the end of the cable.
6. Reinsert the cable and the sheath into the coupler so that all of the bare cable is in the hole.
7. Retighten the four set screws into the threaded holes. Tighten the set screws equally until they contact the cable. Then, tighten each screw alternately 1/4 turn, until all are set to 85 inch/pounds (9.6 Newton-meters).
8. Slide the rubber cover over the coupler, remove the weight pin, and lower the handle.
9. Check for proper tension on the cable as described in CABLE TENSION CHECK on page 8.