



Cybex VR2
Owner's and Service Manual
Strength Systems
Part Number 54599

www.cybexinternational.com



Cybex VR2
Owner's and Service Manual
Strength Systems
Part Number 54599

DISCLAIMER: Cybex International, Inc., makes no representations or warranties regarding the contents of this manual. We reserve the right to revise this document at any time or to make changes to the product described within it without notice or obligation to notify any person of such revisions or changes.

© Copyright 1995, 1996, 1997, 1998, 1999, 2000, 2001, 2002, 2003, 2004 Cybex International, Inc. All rights reserved.

Printed in the United States of America.

10 Trotter Drive Medway, MA 02053 • 508-533-4300 • FAX 508-533-5183

www.cybexinternational.com • Techhelp@cybexintl.com • techpubs@cybexintl.com • 54599 • July 2004

Table of Contents

i Table of Contents

1 Technical Specifications

General Specifications	1-1
VR2 Machine Specifications	1-3

2 General Exercise Guidelines

General	2-1
Glossary	2-2
Single-Set Exercise Chart	
Multiple-Set Exercise Chart	

3 Exercises

Seated Leg Press - 4605	3-1
Leg Extension - 4611, 4612, 4613 . .	3-5
Prone Leg Curl - 4616, 4617, 4618 . .	3-9
Seated Leg Curl - 4626	3-13
Hip Adduction - 4640	3-17
Hip Abduction - 4645	3-19
Rotary Calf - 4620	3-21
Chest Press - Dual Axis - 4507	3-23
Chest Press - Single Axis - 4506	3-27
Incline Press - Dual Axis - 4512	3-29
Incline Press - Single Axis - 4511 . . .	3-33
Pulldown - Dual Axis - 4515	3-37
Row/Rear Delt - Dual Axis - 4520	3-41
Row/Rear Delt - Single Axis - 4521 . . .	3-45
Overhead Press - Dual Axis - 4527 . . .	3-49
Overhead Press - Single Axis - 4526 . .	3-53
Lat Pulldown - Single Axis - 4516 . . .	3-55
Fly - 4545	3-57
Lateral Raise - 4530	3-61
Arm Curl - 4535	3-63
Arm Extension - 4540	3-65
Ab Crunch - 4705	3-67
Back Extension - 4711, 4712, 4713 . .	3-69
Torso Rotation - 4715	3-73

4 Customer Service

Contacting Service	4-1
Ordering Parts	4-1
RMA	4-2
Damaged Parts	4-3

5 Delivery & Installation

Delivery Inspection	5-1
Installation	5-1
Anchoring	5-2
Safety	5-2
Weight Stack Installation Instructions	

6 Maintenance

Daily Procedures	6-1
Weekly Procedures	6-3
Yearly Procedures	6-5
"As Required" Procedures	6-5

7 Service

Grip and Belt Replacement	7-1
Belt Removal	7-3
Belt Installation	7-3
Grip Replacement	7-5
Pivot Shaft Removal	7-6
Pivot Shaft Installation	7-6
Chest Press - Single Axis	4506
Chest Press - Dual Axis	4507
Incline Press - Single Axis	4511
Incline Press - Dual Axis	4512
Pulldown - Dual Axis	4515
Lat Pulldown - Single Axis	4516
Row/Rear Delt - Dual Axis	4520
Row/Rear Delt - Single Axis	4521
Overhead Press - Single Axis	4526
Overhead Press - Dual Axis	4527
Lateral Raise	4530
Arm Curl	4535
Arm Extension	4540
Seated Leg Press	4605
Leg Extension	4611, 4612, 4613
Prone Leg Curl	4616, 4617, 4618
Rotary Calf	4620
Seated Leg Curl	4626
Hip Adduction	4640
Hip Abduction	4645
Ab Crunch	4705
Back Extension	4711, 4712, 4713
Torso Rotation	4715

Chapter 1 - Technical Specifications

General Specifications

Frame Finish

- Shall be made of mechanical quality 11-gauge steel purchased in mill run quantities to assure the best consistency.
- Prior to applying finish, each part shall be put through a multi-stage wash to remove all oils and to chemically prepare the surface for maximum adhesion. After the wash, the frames shall be dried and coated with an Electrostatically applied powdercoat finish that shall be applied in powder form and then baked until cured.
- The finish shall be textured and very hard, assuring a scratch and chip resistant finish.

Weight Selection

- Weights are to be selected by using a high quality selector pin that completely penetrates the weight plate and locks in place to eliminate any chance of disengaging the pin during use. The pin shall be attached to the weight stack with a plastic lanyard in order that the pin stays with the appropriate machine. All weights shall be selected while the user is in position on/in the machine to allow adjustment of the resistance from the exercise position.

Weight Stack Configuration

- All weight stacks shall have 12 1/2-pound weights except for the Standing Calf Raise (Product No. 4875) which shall have 20 pound weight plates.

Increment Weights

- All machines using weight stacks shall have a plastisol-covered increment weight weighing half the amount of a weight stack plate. A hanger for the increment weight shall be incorporated into the frame on the machine.

Weight Plates

- Shall be made of solid cold-rolled steel with wrinkle black powder coat finish.
- Guide rod holes shall be machined to a tolerance of $\pm .006$ inches.

Weight Plate Bushings

- Self-aligning low-friction bushings shall surround the guide rods for smooth gliding motion.

Pulleys

- Shall use Dupont Corp. fiberglass-reinforced nylon 70G33 material, tensile strength rated at 22,500 PSI with 6203ZZ double sealed bearings dynamic load rated at 1600 lbs.
- Pulleys shall 4.50 inches in diameter with a cable groove with a depth of .250 inches.

Cybex VR2 Owner's Manual

Weight Transport

- Shall be lubricated, 7 x 19, 3/16" galvanized steel, nylon coated aircraft cable with breaking strength rated at 4200 pounds.
- All cable ends shall be finished off with a swaged fitting with a breaking strength exceeding that of the cable itself.

Weight Stack Guide Rods

- Shall be solid ground and polished cold-drawn steel with minimum yield strength of 100,000 PSI with a hard chrome plated piston steel finish with an overall minimum accuracy of $\pm .010$.

Weight Stack Suspension

- Shall have heavy-duty neoprene bumpers with a 80 durometer rating under the weight stacks to reduce shock and vibration stresses to the frame and facility.

Cams

- All cams shall be individually designed for each unit to match the appropriate muscle strength capability curve.
- Cams shall be CNC laser cut steel for accuracy and incorporate a cable groove matched to the specific cable diameter.

Counter Balanced Input Arms

- Input arms on equipment shall be counter balanced where appropriate to eliminate the weight of the assembly from the weight selected by the user.

Handgrips

- Plate Loaded machines shall use a closed-end PVC closed cell foam vinyl sleeve.
- Select Plate Loaded shall use either "Grabbaroo" thermoplastic rubber extruded grip material that is non-absorbing, wear and tear resistant, and exhibits good wet and dry friction characteristics.
- Diameter should be 13/8" to increase comfort through reduced pressure.

Frame Construction

- Primarily 1 1/2 x 2" tubing with 11 gauge wall thickness, but different tubing sizes and wall thickness shall be used as required through engineering stress analysis.
- Fully welded frames for maximum structural integrity and minimum maintenance.
- All machining and welding must be done utilizing jigs and fixtures to insure highest quality and inter-changability of parts.

Radial Bearings

- 87503 double shielded bearing with 17-mm stainless steel shafts, dynamic load rating 1660 lbs.

Cybex VR2 Owner's Manual

Hardware

- All 3/8" socket head cap screws shall be of grade 8 (or equivalent). All bolts shall be either chromed or zinc plated for additional corrosion resistance.

Weight Stack Guards

- All weight stacks shall be guarded on the backside to prevent bystanders from inadvertent contact with the weight stack during use.

Cushion/Upholstery

- A superior grade of Naugahyde from Gencorp (or equivalent) shall be used on all pad covers and wear covers.
- The color shall be sulfide stain resistant.
- All edges shall be stitched to eliminate any folds in the material that would limit durability.
- Cushions come with replaceable slipcovers on all high use areas, reducing maintenance expense by not having to replace the entire cushion.
- Cushion foam consists of a combination of high and medium density closed-cell Omalon polyurethane, for durability and comfort.

Adjustments

- Recessed high contrast Lexan decal for all seat and pad adjustments for maximum readability.

Instructional Placard

- Shall provide step-by-step instructions and a picture to illustrate use, visible from the exercise position.
- Placard shall indicate proper positioning, details muscles trained and clearly describe the correct use of machines.

Equipment Anchoring

- Each machine shall be equipped with a provision for anchoring it to the floor.

VR2 Machine Specifications

Seated Leg Press - Product No. 4605

<i>Machine Weight</i>	<i>Weight Stack</i>	<i>Size</i>
1016 lbs.	505 lbs.	inches = 43 W x 89 L x 71 H
462 kg	229 kg	cm = 110 W x 226 L x 181 H

- Four-bar linkage enhances alignment and provides variable resistance.
- Counter-balanced footplate effortlessly adjusts for desired starting position.
- Back pad adjusts to five positions for exercise variation.
- Sliding 5-LB increment weights allow the user to fine-tune resistance levels.

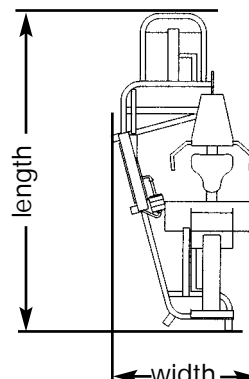

Leg Extension - Product No. 4613, 4612, 4611

<i>Machine Weight</i>	<i>Weight Stack</i>	<i>Size</i>
594 lbs.	305 lbs.	inches = 39 W x 50 L x 61 H
270 kg	139 kg	cm = 99 W x 127 L x 155 H

- Seat back and tibia pad adjusts without affecting knee alignment or start position angle.
- Advanced RLD design maintains integrity of the resistance profile.
- RLD positions are 10° apart with start and end phased by 5° for maximum protection.

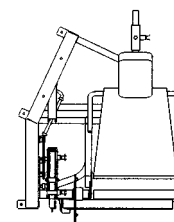

Prone Leg Curl - Product No. 4618, 4617, 4616

<i>Machine Weight</i>	<i>Weight Stack</i>	<i>Size</i>
484 lbs.	205 lbs.	inches = 37 W x 80 L x 61 H
220 kg	93 kg	cm = 94 W x 204 L x 155 H

- Incorporation of elbow pads and handles is more sanitary and encourages a neutral spine.
- Advanced RLD design maintains integrity of the resistance profile.
- RLD positions are 10° apart with start and end phased by 5° for maximum protection.

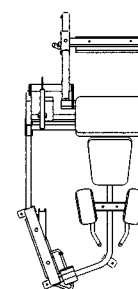

Seated Leg Curl - Product No. 4628, 4627, 4626

<i>Machine Weight</i>	<i>Weight Stack</i>	<i>Size</i>
507 lbs.	205 lbs.	inches = 39 W x 70 L x 61 H
230 kg	93 kg	cm = 99 W x 178 L x 155 H

- Seat back and tibia pad adjusts without affecting knee alignment of start position angle.
- Advanced RLD design maintains integrity of the resistance profile.
- RLD positions are 10° apart with start and end phased by 5° for maximum protection.

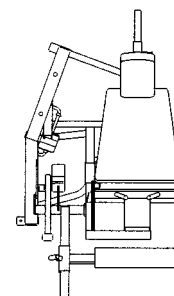

Cybex VR2 Owner's Manual

Hip Adduction - Product No. 4640

<i>Machine Weight</i>	<i>Weight Stack</i>	<i>Size</i>
420 lbs.	205 lbs.	inches = 28 W x 53 L x 55 H
191 kg	93 kg	cm = 71 W x 135 L x 140 H

- Leg support accomplished with kneepads and dual footrests to eliminate unwanted torque around the knee.
- Weight stack positioned in front of user to act as a privacy shield.
- Sliding 5-LB increment weights allow the user to fine-tune resistance levels.

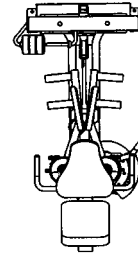

Hip Abduction - Product No. 4645

<i>Machine Weight</i>	<i>Weight Stack</i>	<i>Size</i>
420 lbs.	205 lbs.	inches = 28 W x 53 L x 55 H
191 kg	93 kg	cm = 71 W x 135 L x 140 H

- Leg support accomplished with kneepads and dual footrests to eliminate unwanted torque around the knee.
- Weight stack positioned in front of user to act as a privacy shield.
- Sliding 5-LB increment weights allow the user to fine-tune resistance levels.

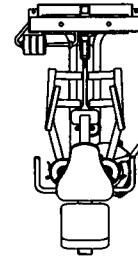

Rotary Calf - Product No. 4620

<i>Machine Weight</i>	<i>Weight Stack</i>	<i>Size</i>
683 lbs.	405 lbs.	inches = 43 W x 59 L x 61 H
310 kg	184 kg	cm = 110 W x 150 L x 155 H

- Footplate rotates through a natural arc keeping the foot in contact with the plate eliminating need to roll the foot over the edge of the plate.
- A seated variable resistance exercise that eliminates the spinal compression found in the traditional standing units.
- Sliding 5-LB increment weights allow the user to fine-tune resistance levels.

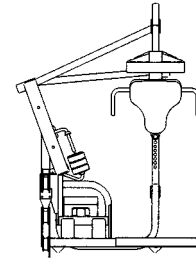

Dual-Axis Chest Press - Product No. 4507

<i>Machine Weight</i>	<i>Weight Stack</i>	<i>Size</i>
611 lbs.	305 lbs.	inches = 56 W x 46 L x 76 H
278 kg	139 kg	cm = 143 W x 117 L x 193 H

- Overhead pivot provides a more natural pattern when compared to lower pivoting units.
- Adjustable starting position allows appropriate range and improves safety.
- Dual Axis Technology[®] provides an innovative "user-defined" motion that allows each user to determine their optimal path, also boosting the effective loading in the muscle.
- Sliding 5-LB increment weights allow the user to fine-tune resistance levels.

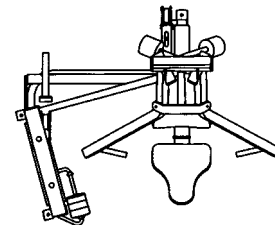

Cybex VR2 Owner's Manual

Single-Axis Chest Press - Product No. 4506

Machine Weight	Weight Stack	Size
559 lbs.	305 lbs.	inches = 56 W x 46 L x 76 H
254 kg	139 kg	cm = 143 W x 117 L x 193 H

- Overhead pivot provides a more natural pattern when compared to lower pivoting units.
- Adjustable starting position allows appropriate range and improves safety.
- Sliding 5-LB increment weights allow the user to fine-tune resistance levels.

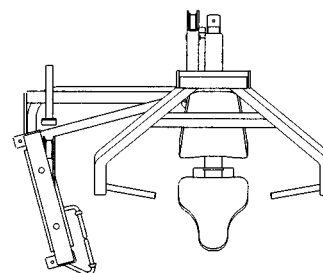

Dual-Axis Incline Press - Product No. 4512

Machine Weight	Weight Stack	Size
610 lbs.	305 lbs.	inches = 56 W x 51 L x 64 H
277 kg	139 kg	cm = 143 W x 130 L x 163 H

- The path of motion is comparable to a 30° incline.
- Overhead pivot geometry provides a more natural arc of motion.
- Dual Axis Technology® provides an innovative “user defined” motion that allows each user to determine their optimal path, also boosting the effective loading in the muscle.
- Sliding 5-LB increment weights allow the user to fine-tune resistance levels.

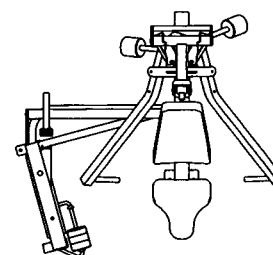

Single-Axis Incline Press - Product No. 4511

Machine Weight	Weight Stack	Size
544 lbs.	305 lbs.	inches = 56 W x 51 L x 64 H
247 kg	139 kg	cm = 143 W x 130 L x 163 H

- The path of motion is comparable to a 30° incline.
- Overhead pivot geometry provides a more natural arc of motion.
- Sliding 5-LB increment weights allow the user to fine-tune resistance levels.

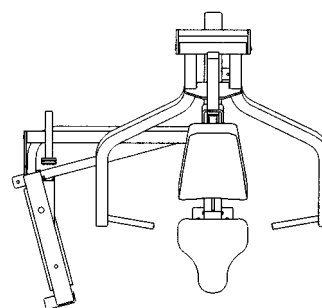

Dual-Axis Pulldown - Product No. 4515

Machine Weight	Weight Stack	Size
630 lbs.	305 lbs.	inches = 39 W x 56 L x 76 H
286 kg	139 kg	cm = 99 W x 142 L x 193 H

- “Free float” handles encourage a user pull to the center rather than “behind the neck”.
- Neutral handles allow a single-axis motion in the sagittal plane.
- Dual Axis Technology® provides an innovative “user defined” motion that allows each user to determine their optimal path, also boosting the effective loading in the muscle.
- Sliding 5-LB increment weights allow the user to fine-tune resistance levels.

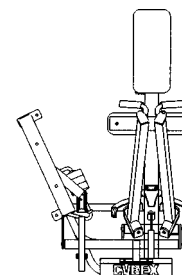

Cybex VR2 Owner's Manual

Dual-Axis Row/Rear Delt - Product No. 4520

Machine Weight	Weight Stack	Size
589 lbs.	305 lbs.	inches = 27 W x 62 L x 82 H
268 kg	139 kg	cm = 69 W x 158 L x 209 H

- Overhead pivot geometry provides a more natural arc of motion, compared to lower pivoting units.
- Dual Axis Technology® provides an innovative “user defined” motion that allows each user to determine their optimal path, also boosting the effective loading in the muscle.
- Sliding 5-LB increment weights allow the user to fine-tune resistance levels.

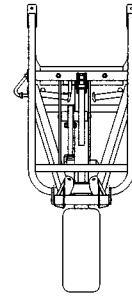

Single-Axis Row/Rear Delt - Product No. 4521

Machine Weight	Weight Stack	Size
574 lbs.	305 lbs.	inches = 27 W x 62 L x 82 H
261 kg	139 kg	cm = 69 W x 158 L x 209 H

- Overhead pivot geometry provides a more natural arc of motion.
- “Traditional” pattern that benefits from superior biomechanical alignment and geometry.
- Sliding 5-LB increment weights allow the user to fine-tune resistance levels.

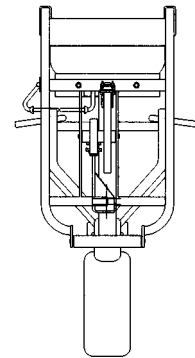

Dual-Axis Overhead Press - Product No. 4527

Machine Weight	Weight Stack	Size
542 lbs.	205 lbs.	inches = 55 W x 62 L x 61 H
246 kg	93 kg	cm = 140 W x 158 L x 155 H

- Counterbalanced input arms allow deconditioned users to develop overhead lifting strength.
- Choice of grips includes a neutral position for individual preference and anatomical limitations.
- Dual Axis Technology® provides an innovative “user defined” motion that allows each user to determine their optimal path, also boosting the effective loading in the muscle.
- Sliding 5-LB increment weights allow the user to fine-tune resistance levels.

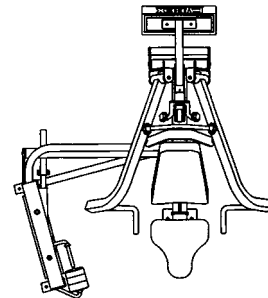

Single-Axis Overhead Press - Product No. 4526

Machine Weight	Weight Stack	Size
519 lbs.	205 lbs.	inches = 55 W x 62 L x 61 H
236 kg	93 kg	cm = 140 W x 158 L x 155 H

- Counterbalanced input arms allow deconditioned users to develop overhead lifting strength.
- Choice of grips includes a neutral position for individual preference and anatomical limitations.
- Sliding 5-LB increment weights allow the user to fine-tune resistance levels.

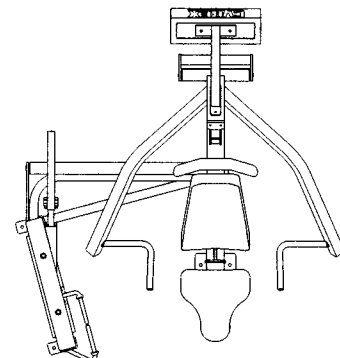

Cybex Strength Systems Specifications

Single-Axis Lat Pulldown - Product No. 4516

<i>Machine Weight</i>	<i>Weight Stack</i>	<i>Size</i>
614 lbs.	305 lbs.	inches = 53 W x 61 L x 76 H
279 kg	139 kg	cm = 135 W x 155 L x 193 H

- Open-style bar design encourages a user pull to the center rather than "behind the neck".
- Handles are angled for optimal position throughout the movement.
- Sliding 5-LB increment weights allow the user to fine-tune resistance levels.

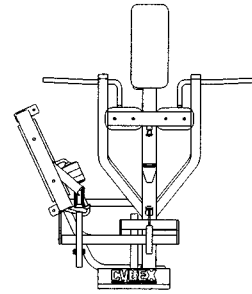

Fly - Product No. 4545

<i>Machine Weight</i>	<i>Weight Stack</i>	<i>Size</i>
473 lbs.	205 lbs.	inches = 53 W x 37 L x 55 H
215 kg	93 kg	cm = 135 W x 94 L x 140 H

- "Floating arm" design accommodates users of all sizes, eliminating the tendency of the pads to "roll" or "scoot" on the arm.
- "Virtual pivot" axis allows the handles to float into optimal position throughout the range of motion.
- Start range of motion adjustment eliminates the most hazardous characteristic of most fly machines, the danger of excessive stretch.
- Sliding 5-LB increment weights allow the user to fine-tune resistance levels.

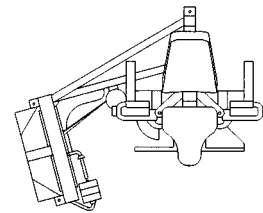

Lateral Raise - Product No. 4530

<i>Machine Weight</i>	<i>Weight Stack</i>	<i>Size</i>
439 lbs.	205 lbs.	inches = 40 W x 52 L x 67 H
199 kg	93 kg	cm = 101 W x 132 L x 170 H

- Horizontal input arms allow the user to vary position for better alignment of the middle deltoid against the resistance.
- Elimination of the standard chest pad allows the user to lean forward for enhanced positioning.
- Sliding 5-LB increment weights allow the user to fine-tune resistance levels.

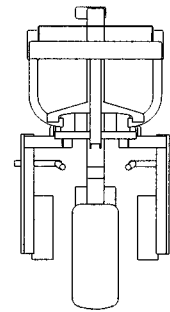

Arm Curl - Product No. 4535

<i>Machine Weight</i>	<i>Weight Stack</i>	<i>Size</i>
410 lbs.	205 lbs.	inches = 38 W x 50 L x 55 H
186 kg	93 kg	cm = 97 H x 127 L x 140 H

- Rotating handles accommodate the user's ability to achieve supination relative to their goal and are angled slightly for proper wrist/grip alignment.
- The arm pad is angled for stability and the axis or pivot point is properly positioned to allow alignment of the elbow joint.
- Sliding 5-LB increment weights allow the user to fine-tune resistance levels.

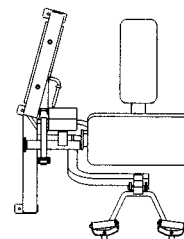

Cybex VR2 Owner's Manual

Arm Extension - Product No. 4540

Machine Weight	Weight Stack	Size
433 lbs.	205 lbs.	inches = 36 W x 51 L x 55 H
197 kg	93 kg	cm = 92 W x 130 L x 140 H

- The input arm automatically adjusts to accommodate varying forearm lengths and a neutral grip position allows full extension without shoulder rotation.
- The arm pad is angled for stability and the axis or pivot point is properly positioned to allow alignment of the elbow joint.
- Sliding 5-LB increment weights allow the user to fine-tune resistance levels.

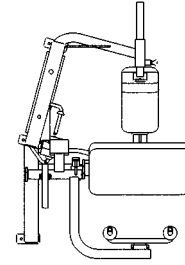

Ab Crunch - Product No. 4705

Machine Weight	Weight Stack	Size
407 lbs.	205 lbs.	inches = 42 W x 42 L x 55 H
185 kg	93 kg	cm = 107 W x 107 L x 140 H

- Pivot point posterior to the spine creates a downward arc of motion matching spinal flexion, creating an improved path for abdominal isolation.
- ROM adjustment via seat height manipulation with fine-tuning made possible by moving back or forward slightly in the seat.
- Sliding 5-LB increment weights allow the user to fine-tune resistance levels.

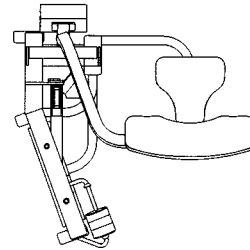

Back Extension - Product No. 4713, 4712, 4711

Machine Weight	Weight Stack	Size
606 lbs.	305 lbs.	inches = 41 W x 50 L x 61 H
275 kg	139 kg	cm = 105 W x 127 L x 155 H

- Provides exceptional alignment and comfort for users of all sizes promoting coordinated function of hip and lower back muscle consistent with proper lifting technique.
- Advanced RLD design maintains integrity of the resistance profile.
- RLD positions are 10° apart with start and end phased by 5° for maximum protection.
- Sliding 5-LB increment weights allow the user to fine-tune resistance levels.

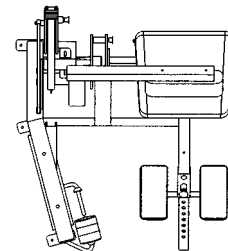

Torso Rotation - Product No. 4715

Machine Weight	Weight Stack	Size
462 lbs.	205 lbs.	inches = 28 W x 43 L x 67 H
211 kg	93 kg	cm = 72 W x 110 L x 171 H

- Innovative design that applies resistance securely through the lower body for efficiency.
- Upper torso assists with stabilization while eliminating the possibility of dizziness by keeping the head stationary.
- "Slackless" drive mechanism for immediate resistance.
- Sliding 5-LB increment weights allow the user to fine-tune resistance levels.

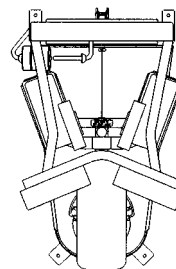

Cybex VR2 Owner's Manual

This page intentionally left blank

Chapter 2 - General Exercise Guidelines

General

Like any sport, strength training involves an element of risk. The following recommendations will help to ensure that training is as productive and safe as possible.

Prior to embarking on any strength training program, it is recommended that each user consult with a physician.

All training sessions should be supervised by trained personnel.

Be sure all warning labels are read and understood by each user.

It is very important that all users be instructed on the proper use of CYBEX Strength Systems products. Pay close attention to the following:

- Set up and alignment for each individual entry and exit from the unit
- Proper form
- Use of seat belts, safety catches and other safety features

To minimize the chance of injury:

- Do not lean on the weight stack or other moving parts
- Keep clear of safety catches, belts and pulleys
- Have a spotter present
- Exercise within physical capabilities and anatomical limitations
- Do not exceed any exercise or movement restrictions prescribed by a doctor, therapist or trainer. This is particularly important for those at risk due to:
 - Known heart disease
 - Known hypertension
 - Obesity

Instruct all users to report any equipment irregularity or personal injury to supervisory personnel immediately.

 WARNING

**SERIOUS INJURY
COULD OCCUR IF
THESE PRECAUTIONS
ARE NOT OBSERVED**

1. Obtain a medical exam prior to beginning an exercise program.
2. Read all warnings and obtain proper instruction on use of the machine prior to using.
3. Keep body and clothing free from and clear of all moving parts.
4. Inspect machine prior to use. **DO NOT** use if it appears damaged or inoperable.
5. **DO NOT** attempt to fix a broken or jammed machine. Notify floor staff.
6. Use the machine only for the intended use. **DO NOT** modify the machine.
7. Be sure that the weight pin is completely inserted. Use only the pin provided by the manufacturer. If unsure seek assistance.
8. Never pin the weights in an elevated position. **DO NOT** use the machine if found in this condition. Seek assistance from floor staff.
9. Children must not be allowed near this machine. Teenagers must be supervised.
10. **DO NOT** use if guards are missing or damaged.
11. **DO NOT** use dumbbells or other incremental weights, except those provided by the manufacturer.
12. Inspect all cables and belts and connections prior to use. **DO NOT** use if any components are worn, frayed, or damaged.
13. **DO NOT REMOVE THIS LABEL. REPLACE IF DAMAGED.**

4605-381 C

Glossary

Abduction - movement away from the mid-line of the body.

Acceleration - the rate at which an object's velocity changes with time; that is the change of velocity divided by the time interval.

Accuracy - freedom from error. Degree of conformity of a measure to a standard or a true value.

Action Line - the direction of pull created by the fibers or tendon of a muscle at the point of application.

Active Insufficiency - a two joint muscle loses the ability to cross-bridge (generate force) due to full shortening over its greatest anatomical length and tension created in an opposing muscle (antagonist).

Active Range of Motion - the degree of motion that occurs between two adjacent segments through voluntary contraction of the agonist (prime mover).

Active Stabilization - provided by an internal force. *Static* stabilization is provided through an isometric contraction where *dynamic* stabilization is a series of motions. *Dynamic* stabilizers maintain the relative positions of the segments, preventing undesirable or unnecessary motions due to external forces as well as artifacts of internal forces. May also refer to the concentric/eccentric contractions of a muscle acting in a force couple to produce motion while maintaining a relatively fixed axis of rotation.

Adipose Tissue - fat tissue.

Adduction - movement towards the mid-line of the body.

Agonist - (prime mover) a muscle that is mechanically optimal to produce a specific motion at a joint. There typically is more than one agonist for a particular motion. A specific muscle can be an agonist for more than one motion at a joint.

Aerobic - with or in the presence of oxygen.

Aerobic Endurance - the ability to persist in physical activities that rely heavily upon oxygen for energy production.

Anabolic - pertaining to the synthesis of complex substances from simpler substances, especially to the synthesis of body proteins from amino acids.

Anaerobic - without oxygen.

Cybex VR2 Owner's Manual

Anaerobic Endurance - the ability to persist in physical activities of short duration that require high rates of energy expenditure. These high rates of energy expenditure cannot be met solely by aerobic metabolism.

Anthropometrics - measurements and relationships of length and girth of body parts.

Antagonist - the muscle in opposition to the agonist.

Anatomical Position - standing erect, with feet and palms facing forward.

Anatomical Pulley - a bone or skeletal prominence that alters the direction of the pull of a muscle to increase the muscle's mechanical advantage.

Anatomy - geography, naming by orientation and/or apparent capability (non-functional).

Anchor Points - the points at which a load enters and exits the body and/or limb.

Anterior - anatomical term meaning towards the front. Same as ventral.

Assistant Mover - a muscle that is less effective at performing a specified motion, but does have a small degree of mechanical ability to help the prime mover. There are many borderline cases.

Atrophy - reduction in size of cells and tissues.

Axis of Rotation - imaginary line or point which an object rotates.

Bilateral - refers to both sides.

Biocomotion - a perspective/description of the human body and its mechanics based upon locomotion. All animals with legs (regardless of numbers) move with the same mechanics. Gravity is the common denominator.

Biomechanics - the study of motion and the effect of forces on biological systems. In resistance training it is the analysis of the load placed on a joint by both the muscle and resistance. Anatomy, Kinesiology, and Physics = Engineering.

Body Composition - the component parts of the body - mainly fat and fat-free weight (lean body mass).

Calorie - a unit of work or energy equal to the amount of heat required to raise the temperature of 1 g of water to 1 degree C.

Cam - a mechanical device used to vary leverage. Based on the fact that a muscles mechanical advantage changes as it moves through a range of motion.

Cybex VR2 Owner's Manual

Carbohydrate - a chemical compound consisting of carbon, hydrogen and oxygen atoms in specified arrangements. Carbohydrates are the chief source of energy for all body functions and anaerobic muscular exertion; they are major components of food such as bread, potatoes and rice.

Cardiovascular - pertaining to the heart and blood vessels.

Cartilage - there are several types. *Hyaline* cartilage is a relatively thin covering on the ends of many bones. It forms a smooth, resilient, low friction surface for the movement of one bone on another. Wedges of cartilage (fibrocartilage) called *menisci*, *disks* and *labrums* function to increase stability, provide shock absorption, and to facilitate motion in some joints.

Center of Gravity - the center of a body's mass. In the human body, it is the point which all parts are in balance with one another. It is dependent on current position in space, anatomical structure, gender, habitual standing posture and if external objects are being held.

Circumduction - a circular movement permitted at ball and socket, condylar and saddle joints. Consists of flexion, abduction, extension and adduction in sequence.

Circuit Training - a type of conditioning program in which exercises are performed in sequence, with little or no rest inbetween stations.

Closed Kinetic Chain Exercise - a series of rigid links interconnected by a series of pin-centered joints. These are constructed so that motion at one joint will produce motion at all the joints in the system. Closed-chain exercises produce greater mechanical efficiency at the risk of increased joint loading. Example, leg press, bench press.

Close-Packed Position - all synovial joints have a position where joint surfaces are maximally congruent and the ligaments and capsule are maximally taut. This is a position of maximal stability and decreased mobility.

Collagen - a fibrous protein that serves as the major component of ligaments and tendons.

Compression - two forces acting along the same line towards each other that constitute a compressive load or compressive stress.

Concentric action - contraction of a muscle resulting in shortening of the muscle. *Positive* work is performed.

Connective Tissue - comprised of mostly the proteins collagen and elastin with water; includes tendons, ligaments, bursae, cartilage, disks, menisci, fascia and bone.

Cross-Bridge - the connection and intertwining of the actin and myosin filaments in a myofibril relative to a muscular contraction.

Curvilinear Motion - the frequently occurring combination of rotatory and translatory motions.

Cybex VR2 Owner's Manual

Distraction - two forces acting along the same line and in opposite directions, they constitute a distractive, tensile load or tensile stress.

Diathrodial Joint - ball and socket joint.

Distal - furthest from the attached end of the limb; away from the body.

Dorsal - pertaining to the back; opposite of ventral, palmar or plantar.

Dorsiflexion - movement of the foot up in the sagittal plane; movement toward the leg.

Eccentric Action - muscle action in which tension is developed in the muscle while it is lengthening. *Negative* work is performed.

Endurance - the ability to persist in performing some physical activity.

Energy - the capacity to perform work.

Energy (Kinetic) - energy associated with motion.

Energy (Potential) - energy by virtue of position.

Energy System - one of three metabolic systems involving a series of chemical reactions resulting in the formation of waste products and the manufacture of ATP.

Eversion - movement of the sole of the foot outward; opposite of inversion.

Extension - movement about a joint in which bones on either side of the joint are brought away from each other, bringing two parts into or towards a straight line, increasing the angle of the joint. Returning to anatomical position from a position of flexion in the sagittal plane.

External Force - a push or pull on the body that arises from a source outside the body.

External Rotation - movement of the anterior surface of a segment away from the mid-line; also termed lateral rotation.

Fast Twitch Fibers - skeletal muscle fibers most active in short-duration, intensive exercise, e.g., in sprints and jumps.

Fatigue - the inability to maintain a given level of physical performance.

Flexibility - the range of movement of a specific joint or group of joints, influenced by the associated bones and bony structures, muscles, tendons and ligaments.

Flexion - movement about a joint in which bones on either side of the joint are brought closer together, decreasing the angle of the joint. Joint movement away from anatomical position, occurring within the sagittal plane.

Cybex VR2 Owner's Manual

Foot-Pound - the work required to move one pound of resistance one foot in distance.

Force - an interaction between two objects, in the form of a push or pull, that may or may not produce motion, Force = mass x acceleration.

Force Angle - (FA) the angle between the action line and the lever, on the side of the joint axis. It is *not* directly related to the joint angle and changes as the muscle's relationship to the bone changes during motion

Force Couple - concentric/eccentric contractions of opposing muscles acting to produce motion while maintaining a relatively fixed axis of rotation. A prime example occurs in the shoulder, where the deltoid and rotator cuff muscles' divergent pull create an *almost* perfect spinning of the humeral head around a fixed axis of rotation.

Frontal Plane - (coronal) imaginary line that divides the body into anterior and posterior halves; lies at a right angle to the sagittal plane.

Fulcrum - the support on which a lever rotates in moving or lifting.

Hyperextension - continuation of the movement of extension past the neutral position.

Hypertension - a chronic elevation of arterial blood pressure which is a primary risk factor for coronary artery disease and stroke.

Hypertrophy - increased cell size leading to increased tissue size.

Impulse - the *change in* momentum. This becomes a concern in weight training, due to the possible negative effects associated with it.

Inertia - the tendency of a body to remain at rest or continue in uniform motion unless acted on by an unbalanced force. Represents Newton's first law, the law of inertia.

Inferior - a lower position upon or within the body.

Insertion - the more distal attachment site of a muscle. The movable part or attachment of a muscle as opposed to origin.

Intermittent Work - work sessions interrupted by rest sessions.

Internal Forces - act on the body and arise from sources within the human body.

Inversion - moving the sole of the foot inward. Opposite of eversion.

Isokinetic Contraction - a muscular contraction through a range of motion at a constant velocity. The rate of movement is maintained at a constant velocity through a specific range of motion even though maximal force is exerted.

Cybex VR2 Owner's Manual

Isometric (Static) Contraction - a muscular contraction in which tension is produced but there is no change in the angle of the involved joint(s) involved.

Isotonic Contraction - a muscular contraction in which a constant resistance is moved through a range of motion of the involved joint(s). Movement in this type of contraction typically involves both a concentric and an eccentric contraction.

Joint Play - "slack" in the connective tissues surrounding the joint that is required to allow normal joint motion.

Kilocalorie - a unit of work or energy equal to the amount of heat required to raise the temperature of 1 kg of water 1 degree C.

Kinematics - area of study that examines the spatial and temporal components of motion (position, velocity and acceleration).

Kinesiology - The scientific study of human movement.

Kinetic energy - energy associated with motion.

Kinetics - area of study that examines the forces that act on a system.

Kyphosis - neutral/normal sagittal curvature of the thoracic spine. Excessive kyphosis is often accompanied by rounded shoulders.

Lactic Acid (Lactate) - the temporary end-product of anaerobic glucose metabolism (glycolysis).

Lean Body Mass - body weight minus body fat; composed of muscle, bone and other non-fat tissue.

Lever - a rigid bar that rotates around a fixed support (fulcrum) in response to an applied force.

Lever Systems - a force system existing whenever two or more parallel forces, whose actions lines will never converge, act on the same object but at some distance from each other. The three classifications are *first*, *second* and *third* class levers.

Ligament - a band of fibrous connective tissue that binds bone to bone; functions to maintain integrity of a joint.

Lordosis - neutral/normal forward curvature of the lumbar and cervical spine.

Luxation - complete joint dislocation.

Mass - the amount of matter an object contains, or the number of atoms. Unlike weight, an objects mass is constant, despite the value of gravitational acceleration. Mass is a determiner of an object's inertia.

Cybex VR2 Owner's Manual

Mechanical Efficiency - greater mechanical efficiency, relative to resistance training, means less muscular force is required to move a load and therefore greater stress is transferred through the skeletal system. The *value* of the system utilized becomes dependent upon the *goal*.

Medial Rotation - movement around an axis and toward the mid-line of the body. Also termed internal rotation.

Medial - aspect nearest the mid-line of the body; pertaining to the center. Opposite of lateral.

Metabolism - the sum total of the energy-producing and -absorbing processes in the body. The energy used by the body.

Moment Arm - (MA) the shortest distance between the action line and the joint axis.

Momentum - the product of the mass of a body and its velocity. It will remain constant (it is "conserved") unless the object is acted upon by another force.

Muscle Contraction - shortening of a muscle and/or development of tension in a muscle.

Muscular Endurance - the ability of a muscle or muscle group to perform repeated contractions against a load for an extended period of time.

Neutral - a point between the two extremes of a joint's range of motion.

Obesity - the clinical classification of a percent body fat greater than 25% (males) or 30% (females).

Open Kinematic Chain - the ends of the limbs or parts are free to move without causing motion at another joint. Open chain motions are not predictable because the joints may function either independently or in unison. Less mechanically efficient, therefore more stress is placed upon muscular tissue. Examples, dumbbell presses and curls.

Origin - attachment of a muscle that remains relatively fixed during muscular contraction.

Overload - stressing the body or parts against resistance greater than that which is normally encountered. The resistance (load) can be maximal or near-maximal.

Passive Insufficiency - the point at which a two-joint muscle loses the ability to cross-bridge (generate force) due to full lengthening over its greatest anatomical length due to force created in an opposing muscle.

Passive Stabilization - a type of stabilization that is due to non-contractile components. This can be accomplished *internally* by connective tissue (in situations of non-muscular support); or through *external* structures such as a bench or brace.

Plane of Motion - a two-dimensional flat surface running through an object. Motion occurs in the plane or parallel to the plane.

Cybex VR2 Owner's Manual

Plantar - anatomical term referring to the sole or bottom.

Plantarflexion - movement of the foot down in the sagittal plane; movement away from the leg.

Posterior - anatomical term meaning toward the back. Opposite of anterior.

Potential Energy - energy by virtue of position.

Power - the product of *work* divided by time. It is the *time* required to move a *distance* that was produced by the *force*.

Prime Mover - (agonist) a muscle that is mechanically optimal to produce a specific motion at a joint. There can be more than one prime mover for a particular motion, and a specific muscle can be a prime mover for more than one motion at a joint.

Progressive Resistance - overloading a muscle or muscle group consistently throughout the duration of a weight-resistance program.

Pronation - a triplanar motion at the subtalar joint consisting of abduction, depression and eversion, resulting in lowering of the longitudinal arch of the foot. Position of the forearm with the palm facing down.

Protein - an essential nutrient made up of amino acids. The building block for tissues.

Proximal - towards the attached end of the limb or origin.

Range of Motion (ROM) - the amount of motion available to a joint (measured in degrees) within the anatomical limits of the joint structure. Limits to range of motion also include physiological, biomechanical, and neural. ROM can be classified as *Passive* (movement produced via a force outside the limb), *Active* (movement produced by muscles within the limb) or *Resisted* (movement challenged under additional load).

Reciprocal Inhibition - contraction of agonist causes relaxation of antagonist.

Repetition Maximum (RM) - the maximum load that a muscle or muscle group can lift for given number of repetitions before fatiguing. Example, an eight-RM load is the maximum load that can be lifted eight times.

Rotary Motion - (radial or angular) the movement of an object around a fixed axis in a curved path.

S.A.I.D. Principle - Specific Adaptation to Imposed Demand. A muscle will gain strength in the specific ranges of motion and speeds in which it is trained.

Sagittal Plane - Imaginary line that divides the body, or any of its parts, into right and left sections.

Cybex VR2 Owner's Manual

Scoliosis - a lateral curvature of the vertebral column, usually in the thoracic area.

Secondary Joint - hinge joints that have a singular function (elbow/knee). Muscles are situated on either side of these joints in virtual, if not real, pairings.

Set - in an interval training program, a group of work and relief intervals. In weight lifting, the number of repetitions performed consecutively without resting.

Shear - two parallel forces applied in opposite directions that are not in line with each other constitute a shearing load or stress within the object to which they are applied. Normal joint motion is always associated with some degree of shearing stress due to normal muscular action against resistance (weight of the limb, etc).

Shunt Muscle - directs the greater part of its contractile force along the bone it is moving (creating greater force towards compression/stabilization). Example, the brachioradialis muscle of the forearm is a shunt during an arm curl.

Skeletal Muscle - muscle controlling skeletal movement that is normally under voluntary control.

Sliding Filament Theory - a muscle shortens or lengthens due to the thick and thin myofibrils sliding past one another without the filaments changing length.

Slow-twitch Fibers - skeletal muscle fibers characterized by relatively slow contractile speeds and great capacity for the aerobic production of adenosine triphosphate (ATP).

Sprain - the permanent deformation of the structure due to excessive or prolonged stress/strain.

Spurt Muscle - directs the greater part of its force across the bone it is moving rather than along it (creating greater effort towards motion). Example, the biceps is a spurt during an arm curl.

Stabilizer - a muscle that steadies or supports an adjacent joint in order for another active muscle to have a firm base upon which to pull. A muscle may be a stabilizer for one motion, and a prime mover (agonist) for another motion.

Static Contraction - a muscular contraction that does not involve changes in the angle of the joint(s) involved.

Steady State - that state of physiological stability wherein the energy demands of the body can be met relatively easily for a prolonged period of time.

Strain - the deformation of the structure as the result of stress.

Strength - the ability to exert muscular force briefly.

Stress - the force created within a structure when placed under load.

Cybex VR2 Owner's Manual

Subluxation - a partial dislocation of a joint; usually reduces itself.

Submaximal Exercise - exercise at less than maximal intensity, may also refer to exercise of less than maximal duration.

Superior - a higher position upon or within the body.

Synergist - occurs during the action of two muscles, both of which have a common joint action and each of which has a second action that is antagonistic or opposing to the other. True synergy is simply the stabilization of one muscle to prevent any action in one of the joints traversed by a multi-joint muscle.

Synovial Fluid - a transparent, viscous lubricating fluid found in joint cavities, bursae and tendon sheaths.

Tendons - cords of dense fibrous tissue that connect muscle to bone.

Tertiary Joint - a complex joint structure (wrist/ankle-subtalar), designed for finely controlled movements.

Torque - the ability of a force to produce movement around an axis.

Translatory Motion - (linear) the movement of an object in a straight line.

Unilateral - refers to only one side.

Vector - typically represented by a drawn arrow, representing a force's point of application, action line or direction indicating pull or magnitude of force being exerted.

Vector Shift - a manipulation of the force or loadline through the chain by altering the position of the anchors relative to the joints or vice versa.

Velocity - the rate at which an objects position changes with time; that is the total change in position divided by the total change in time: $V=d/t$.

Weight - a unit of heaviness which is the product of the mass of an object and the gravitational force exerted on it by the earth. $W=mg$, where g = gravitational acceleration.

Work - $W = Fd$. The amount of work performed is equivalent to the force applied to an object times the distance the object is moved.

Multiple-Set Training Diary

MACHINE	Seat Pad	Date																								
		Set	1	2	3	1	2	3	1	2	3	1	2	3	1	2	3	1	2	3	1	2	3			
		Plates																								
		Reps																								
		Plates																								
		Reps																								
		Plates																								
		Reps																								
		Plates																								
		Reps																								
		Plates																								
		Reps																								
		Plates																								
		Reps																								
		Plates																								
		Reps																								
		Plates																								
		Reps																								

MACHINE	Seat Pad	Date	1			2			3			1			2			3			1			2			3			
			Set	1	2	3	Set	1	2	3	Set	1	2	3	Set	1	2	3	Set	1	2	3	Set	1	2	3	Set	1	2	3
		Plates																												
		Reps																												
		Plates																												
		Reps																												
		Plates																												
		Reps																												
		Plates																												
		Reps																												
		Plates																												
		Reps																												
		Plates																												
		Reps																												
		Plates																												
		Reps																												

Seated Leg Press

The Machine

- **Arc of Motion** - The machine pivots from below creating an arc congruent with the functional movement of the legs. This also decreases the detrimental forces on the knee by maintaining an optimum knee/foot relationship throughout the range of motion. A leg press that pivots from above or that moves in a linear path is inconsistent with the natural arc of motion and creates excessive forces within the knee during flexion.
- **Accommodating Footplate** - The movement of the footplate eliminates excessive motion at the ankle and maintains a near neutral position, decreasing undue forces throughout the lower extremity.
- **Range of Motion Adjustment** - The starting position and range of motion limit are both adjusted from a control pin below the legs. Adjustment is accomplished through the near effortless movement of the footplate. By moving the footplate rather than the seat the legs are always traveling through the appropriate arc of motion with the appropriate resistance.
- **Seat Angle Adjustment** - The back of the seat adjusts to vary the hip position and motion. Five positions are available in five degree increments. The position of the seat is comfort and goal dependent.
- **Variable Resistance** - A cam provides appropriately varying resistance that is maximal at the end of the motion where the body's mechanical advantage increases.
- **10 to 505 Pounds by Fives** - The top plate provides a minimum weight of ten pounds. Subsequent plates in the weight stack are twenty pounds each. Three "slide-on" five pound incremental plates are securely positioned for easy access and effortless addition thereby providing 10 to 505 pounds in five pound increments.

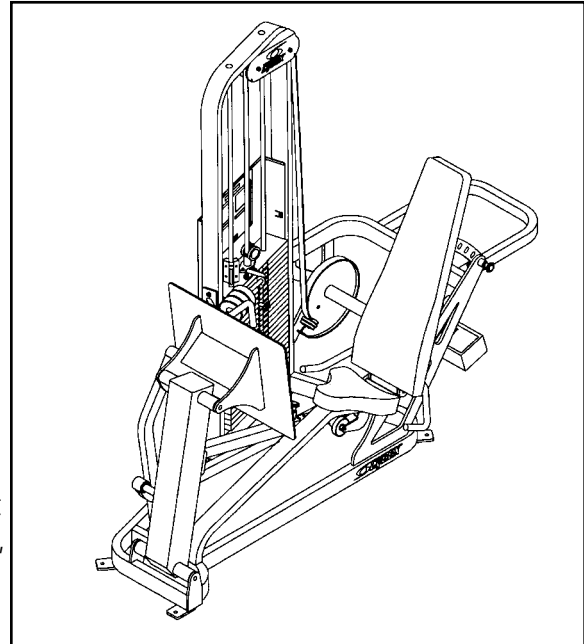

Closed Kinematic Chain Leg Extension

- **Hip/Knee Extension** - The quadriceps are responsible for extension of the knee joint. The gluteus maximus and hamstring are responsible for hip extension. The hip-knee relationship in closed kinematic chain extension represents an indirect proportion. An increase in hip motion will increase hip extensor work and proportionally decrease knee extensor work, and vice versa.
- **Knee Tracking** - Functioning as a hinge, it is imperative that the knee be directed toward the toes when eccentrically flexing or concentrically extending during closed chain movements. Exactly which toe(s) the knee is to be directed towards is dependent upon the anatomical structure of the user. It is commonly suggested that the knee track between the big and second toes. However, if a marked Q-angle is noted, tracking is recommended more toward the fifth (little) toe. Comfort is also a factor in the decision. Ultimately, once the proper tracking has been determined, it must be monitored and maintained throughout each repetition.
- **Range of Motion** - The range of motion is limited by spinal alignment during eccentric flexion and at full knee extension concentrically. Hyperextension of the knee is to be avoided in closed chain leg work.
- **Associated Muscles** - Hip adductor involvement varies with foot placement. As the feet are placed wider and the knees track accordingly, hip adduction is increased.

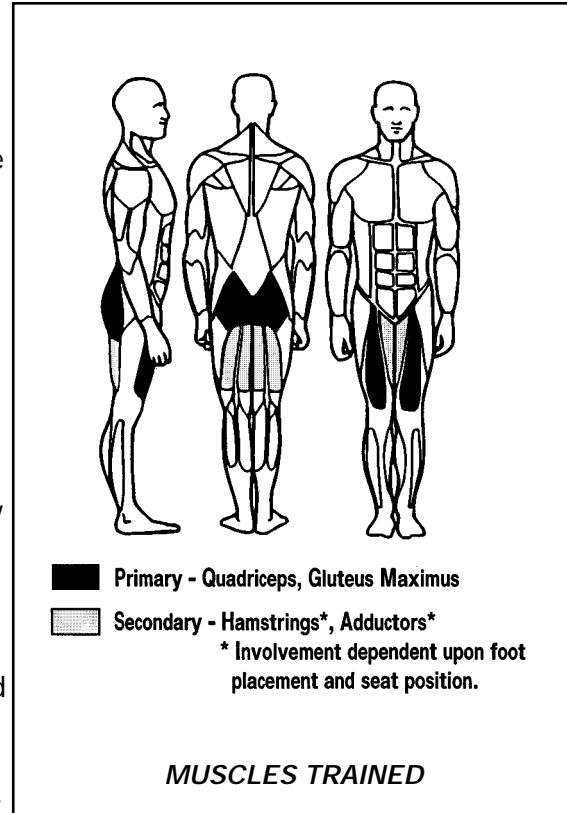

The Positioning

- Adjust the back pad to comfort or goal. Raising the pad will increase hip extensor work. Lowering the pad will decrease hip extensor work.
- Adjust the starting position (pull pin found below the legs) to allow approximately a 90 degree bend in the knee. The need for more or less knee flexion is determined by the users goal and limitations. The degree of knee bend must allow the pelvis/hips to remain firmly pressed against the back pad.
- Check the weight to insure that the appropriate resistance has been selected. Body position and control of the motion should never be compromised by excessive weight.
- Position the feet approximately shoulder width with the toes and knees pointing slightly outward at the same angle.
- Position the shoulders and hips/pelvis against the back pad and maintain to eliminate spinal flexion.

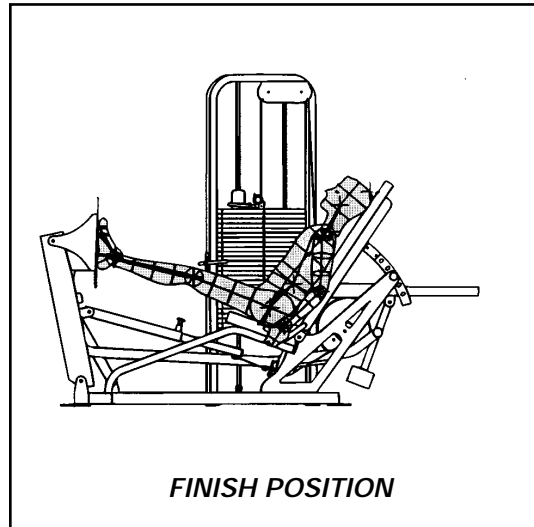
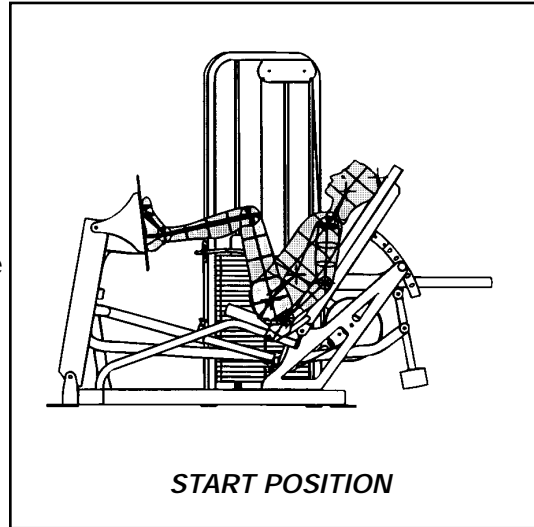

The Motion

- Keeping the feet flat, tighten the legs, push through the heels and smoothly straighten the legs. Do not lock/hyperextend the knees.
- Slowly return to the starting position without resting.
- Maintain the hips/pelvis and shoulders against the back pad and the knees pointing toward the toes throughout each repetition.

CYBEX VR2 Owner's Manual

(This page intentionally left blank)

Leg Extension

The Machine

- **Three Models** - The 4611 model provides standard (non-RLD) operation. The 4612 model contains an adjustable start position so that the ultimate degree of knee flexion at the start of the movement can be determined. The 4613 model provides both an adjustable start and an adjustable end position for total control of the user's range of motion.
- **Range of Motion Limitation** - The range limiting device allows quick, easy adjustment of the start (4612, 4613) and end positions (4613) for those user's with limited hamstring flexibility or for rehab purposes. The RLD maintains the correct biomechanical relationship between the lever arm and the cam which is critical in maintaining the proper resistance variation through the chosen range.
- **Axis Alignment** - The axis or pivot point of the machine is properly positioned to allow alignment with the knee joints.
- **Back Pad** - The back pad is angled 100 degrees from the seat to allow for hamstring length.
- **Variable Resistance** - The cam provides increased resistance at the point in the range where force output of the quadriceps is the greatest.
- **10 to 305 Pounds by Fives** - The top plate provides a minimum weight of pounds. Subsequent plates in the weight stack are twenty pounds each. Three "slide-on" five pound incremental plates are securely positioned for easy access and effortless addition thereby providing 10 to 305 pounds in five pound increments.

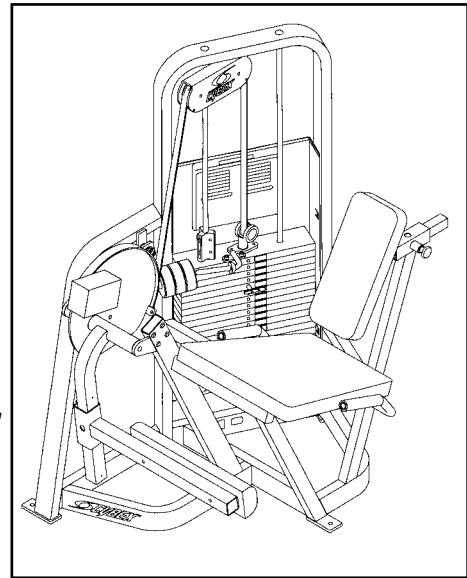

The Quadriceps

- **Knee Extension** - The quadriceps are responsible for extension of the knee joint. Although the vastus medialis and vastus lateralis are pulling at slightly different angles on the patella, the knee joint functions as a hinge. Attempts at emphasizing either of these two muscles by altering knee alignment will have limited effect on the muscle and detrimental effects on the joint itself. It should be noted for alignment purposes that the axis of the knee joint is actually near the posterior aspect of the knee.

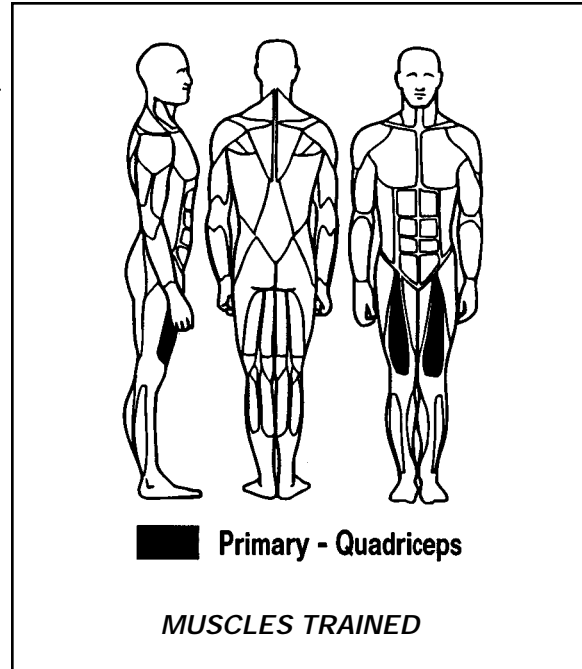

- **Range of Motion** - The normal range of motion is generally considered to be -10 to 135 degrees. Unless a restriction occurs or is prescribed, range of motion is limited only by the user's ability to control the quads concentrically into full extension and eccentrically into flexion. Full extension on the Leg Extension (an open chain exercise) does not place forces on the knee that furthers hyperextension, as is the case in a closed chain exercise. In full extension, the least compressive force is placed on the patella. As range of motion increases, the compressive forces on the patella increase. Ninety degrees (where patellar compression equals eight times the resistance applied) is often regarded as being the end of safely resisted extension, however, this remains an individual matter. Normal cruciate ligaments safely counter shearing forces developed in this exercise. The hamstring can be a limiting factor in achieving full knee extension if the hip is positioned at 90 degrees.

The Positioning

- Note the pivot point at the front right corner of the seat.
- Align the axis of the knees and adjust the back pad to maintain that position.
- Adjust the leg pad to comfort.
- Check the weight to insure that the appropriate resistance has been selected. Body position and control of the motion should never be compromised by excessive weight.
- Position the thighs parallel to each other and relax the ankles.
- Grip the handles to remain firmly against the seat and maintain proper posture.

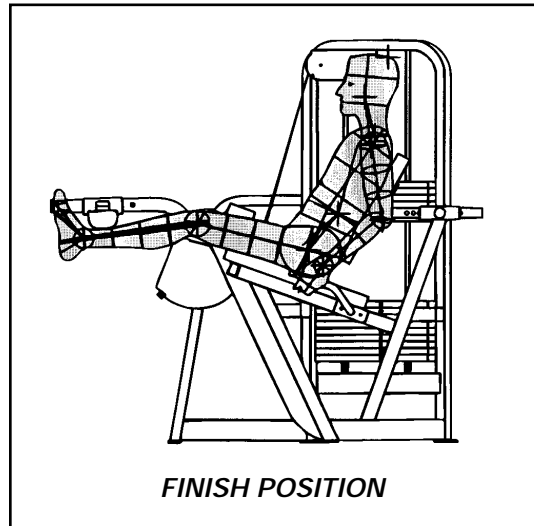
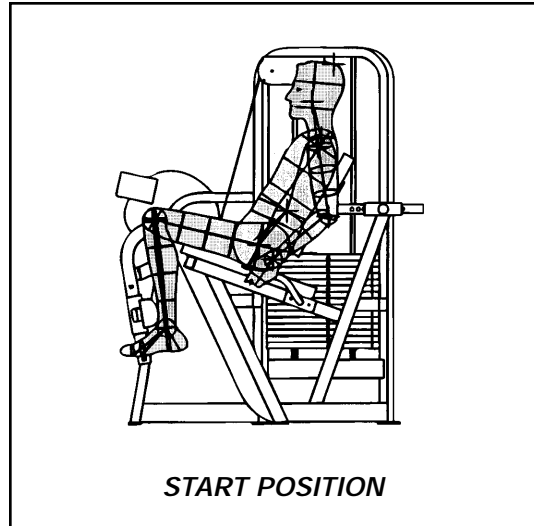

The Motion

- Tighten the quadriceps and straighten the knees as far as possible. **NOTE:** Do not kick.
- On the first repetition further align the knees by rotating the thighs to position the patella directly on top/center of the knees. Maintain this position throughout each repetition.
- Return to the starting position without resting.

The Positioning

- **Set Start Position**

1. Grasp pull pin (pullbutton) and pull.
2. Move input arm to desired position.
3. Lock pull pin into place.

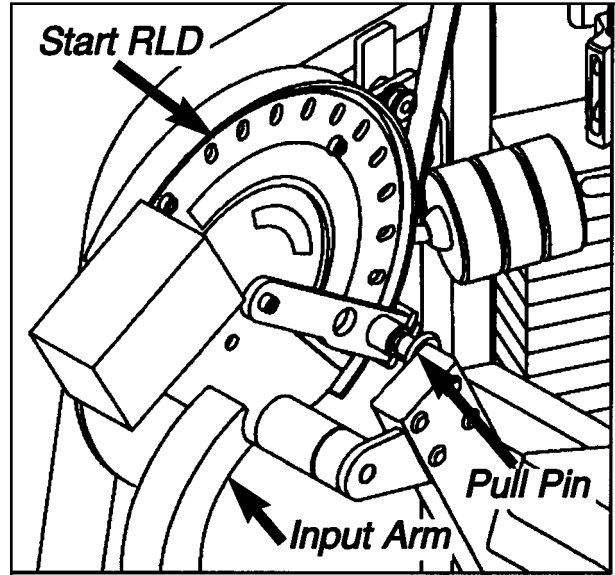

- **Set Stop (End) Position**

1. Grasp pull pin (pullbutton) and pull.
2. Rotate stop to the desired end position.
3. Lock pull pin into place.

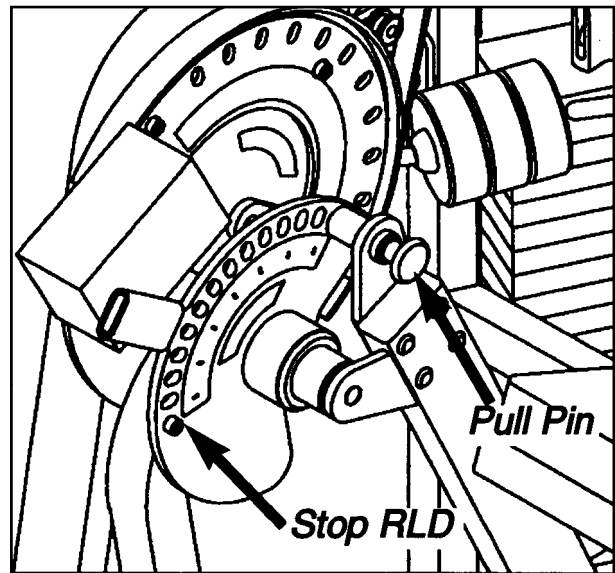

Prone Leg Curl

The Machine

- **Three Models** - The 4616 model provides standard (non-RLD) operation. The 4617 model contains an adjustable start position so that the ultimate degree of knee flexion at the start of the movement can be determined. The 4618 model provides both an adjustable start and an adjustable end position for total control of the user's range of motion.
- **Range of Motion Limitation** - The range limiting device allows quick, easy adjustment of the start (4617, 4618) and end positions (4618) for those user's with limited hamstring flexibility or for rehab purposes. The RLD maintains the correct biomechanical relationship between the lever arm and the cam which is critical in maintaining the proper resistance variation through the chosen range.
- **Axis Alignment** - The axis or pivot point of the machine is properly positioned to allow alignment with the knee joints.
- **Hip/Spinal Stabilization** - The increased angles of the trunk and thigh pads encourages hip and spinal stabilization dramatically.
- **Cervical Alignment** - The shortened trunk pad eliminates the cervical hyperextension and/or rotation encouraged by the longer trunk pad.
- **Variable Resistance** - The cam provides increased resistance at the point in the range where force output of the hamstrings is the greatest.
- **10 to 205 Pounds by Fives** - The top plate provides a minimum weight of ten pounds. Subsequent plates in the weight stack are twenty pounds each. Three "slide-on" five pound incremental plates are securely positioned for easy access and effortless addition thereby providing 10 to 205 pounds in five pound increments.

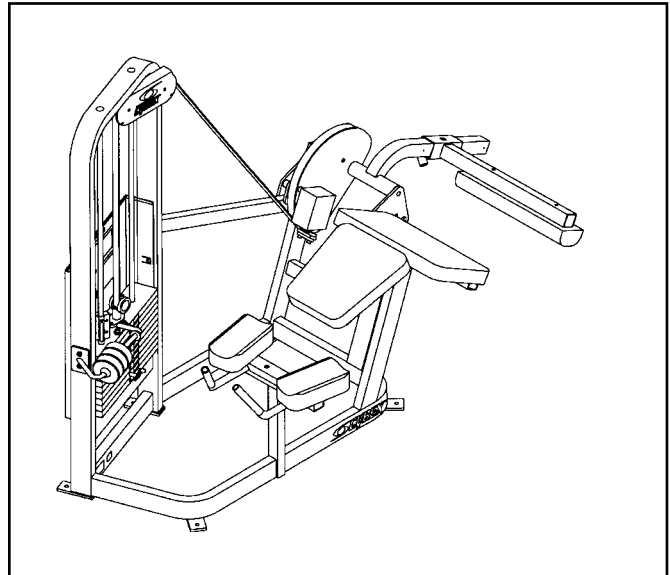

The Hamstring

- **Knee Flexion** - The hamstring group is responsible for flexion of the knee joint. The hamstrings also cross the hip joint and are responsible for hip extension. It should be noted that any movement of the hip joint during resisted knee flexion usually decreases the effectiveness of the exercise by allowing unrelated change in the hamstring's length.
- **Range of Motion** - The normal range of motion is generally considered to be -10 to 135 degrees. The hamstring is limited by mechanical disadvantage near full extension (eccentric "lowering of the weight"). Due to the direction of resistance and the availability of hyperextension at the knee, it is advised to limit the eccentric movement just short of full extension. Flexion is only limited by concentric control.

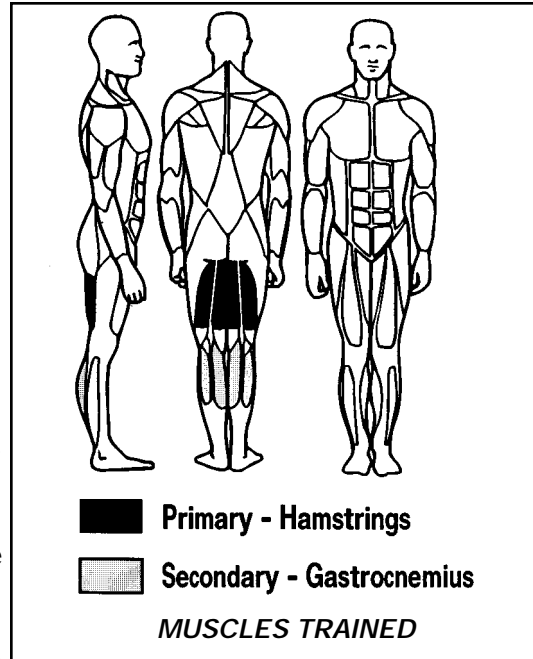

- **Associated Muscles** - The gastrocnemius is an assistant mover for knee flexion. It can be discouraged from use by attempting to completely relax the ankle muscles or by plantar flexing the ankle. Plantar flexion shortens the gastroc and as knee flexion occurs the muscle will achieve a condition of "active insufficiency". However, the fact that the gastroc is involved in plantar flexion can further its involvement through much of the knee motion. Dorsiflexion encourages gastroc contraction. The gracilis, sartorius and plantaris are also assistant movers for knee flexion.

The Positioning

- Adjust the leg pad comfortably behind the ankles.
- Check the weight to insure that the appropriate resistance has been selected. Body position and control of the motion should never be compromised by excessive weight.
- Note the pivot point at the lower right corner of the thigh pad.
- Align the knees with the pivot point while lying prone on the machine. The top of the patella should be at the edge of the thigh pad.
- With the ankles against the leg pad, position the legs and feet parallel, ankles neutral and relaxed or plantar flexed.
- Grip the handles and rest the forearms on the arm pads.
- Stabilize the spine with the abdominals to prevent hyperextension.
- Tighten the hamstrings and *slightly* lift the knees.

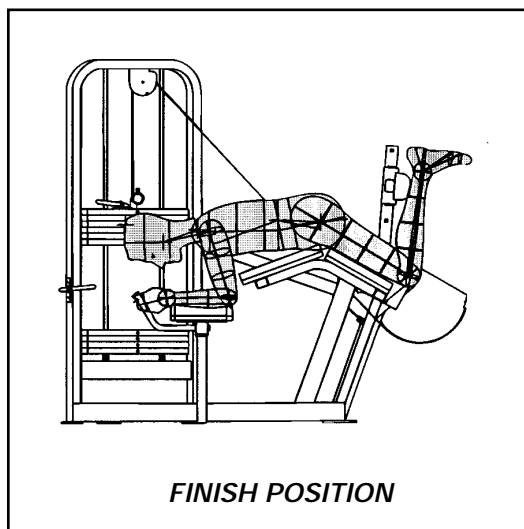
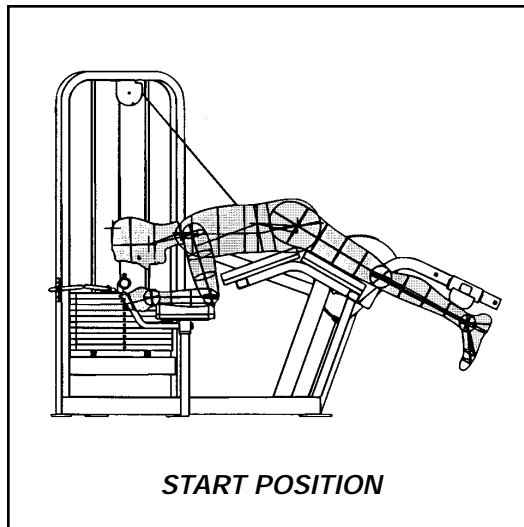

The Motion

- Smoothly flex the knees as far as possible without raising the knees further, without elevating the hips, and without hyperextending the spine.
- Slowly return to a position near full extension and without resting or dropping the knees.

The Positioning

- **Set Start Position**

1. Grasp pull pin (pullbutton) and pull.
2. Move input arm to desired position.
3. Lock pull pin into place.

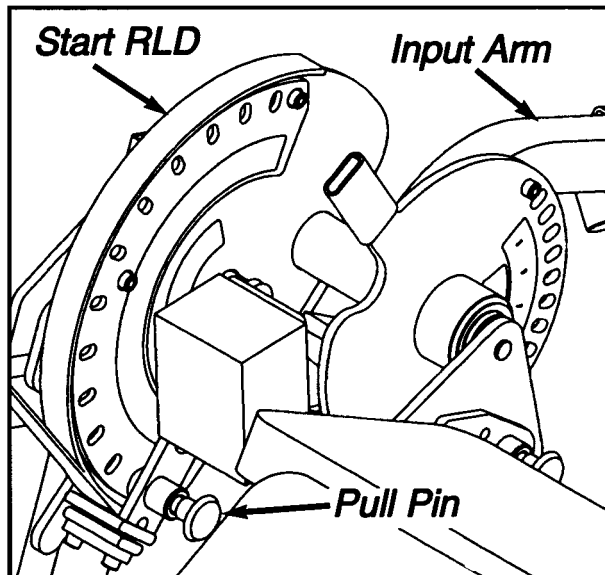

- **Set Stop (End) Position**

1. Grasp pull pin (pullbutton) and pull.
2. Rotate stop to the desired starting position.
3. Lock pull pin into place.

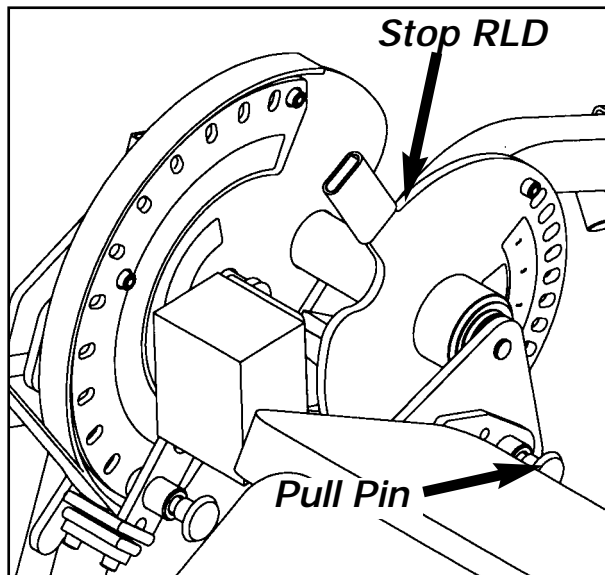

Seated Leg Curl

The Machine

- **Three Models** - The 4626 model provides standard (non-RLD) operation. The 4627 model contains an adjustable start position so that the ultimate degree of knee flexion at the start of the movement can be determined. The 4628 model provides both an adjustable start and an adjustable end position for total control of the user's range of motion.
- **Range of Motion Limitation** - The range limiting device allows quick, easy adjustment of the start (4627, 4628) and end positions (4628) for those user's with limited hamstring flexibility or for rehab purposes. The RLD maintains the correct biomechanical relationship between the lever arm and the cam which is critical in maintaining the proper resistance variation through the chosen range.
- **Seated Position** - The upright position allows a more comfortable positioning of the "body in space", positively affecting associated physiological factors such as positional hypertension and vestibular stimulation. The degree of hip flexion associated with the seated position is useful in strengthening the hamstring at its greatest length. This is often considered "position/length specific" for goals such as rehab and sport and is ideal for general fitness as well.
- **Axial Alignment** - The axis or pivot point of the machine is properly positioned to allow alignment with the knee joints.
- **Thigh Stabilization** - Femur stabilization is provided by a superiorly (top) positioned pad. This approach to stabilization is key to preventing elevation of the knee/thigh which is otherwise inevitable during the initial phase of each repetition. This pad is easily adjusted for the individual user's thigh thickness and axial alignment and also offers quick release for exiting the machine.
- **Variable Resistance** - The cam provides increased resistance at the point in the range where force output of the hamstrings is the greatest.
- **10 to 205 Pounds by Fives** - The top plate provides a minimum weight of ten pounds. Subsequent plates in the weight stack are twenty pounds each. Three "slide-on" five pound incremental plates are securely positioned for easy access and effortless addition thereby providing 10 to 205 pounds in five pound increments.

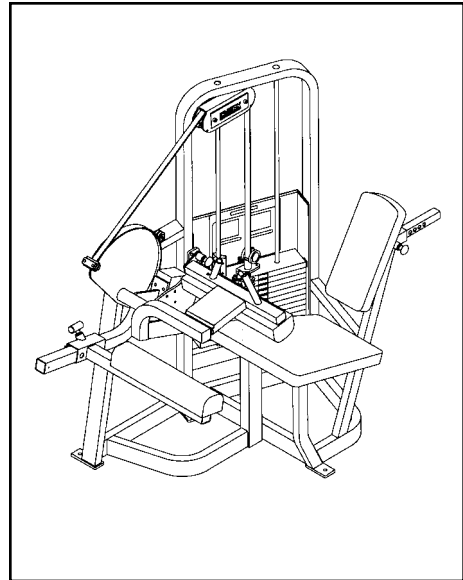

The Hamstring

- **Knee Flexion** - The hamstring group is responsible for flexion of the knee joint. The hamstrings also cross the hip joint and are responsible for hip extension. Altering the stabilized position of the hip creates variety for resisted knee flexion exercises. It should be noted that any movement of the hip joint (loss of stabilization) that occurs during resisted knee flexion usually decreases the effectiveness of the exercise by allowing unresisted change in the hamstring's length.
- **Range of Motion** - The normal range of knee motion is generally considered to be -10 to 135 degrees. The hamstring is limited by mechanical disadvantage near full extension (eccentric "lowering of the weight"). Due to the direction of resistance and the availability of hyperextension at the knee, it is advised to limit the eccentric movement just short of full extension. Due to the position of hip flexion near 90 degrees, many users will not be able to achieve even this degree of extension eccentrically due to poor hamstring flexibility. Resisted knee flexion is limited only by concentric control.
- **Associated Muscles** - The gastrocnemius is an assistant mover for knee flexion. It can be discouraged from use by attempting to completely relax the ankle muscles or by planter flexing the ankle. Plantar flexion shortens the gastroc and as knee flexion occurs the muscle will achieve a condition of active insufficiency. However, the fact that the gastroc is involved in plantar flexion can further its involvement through much of the knee motion. Dorsiflexion encourages gastroc contraction. The gracilis, sartorius, and plantaris are also assistant movers for knee flexion.

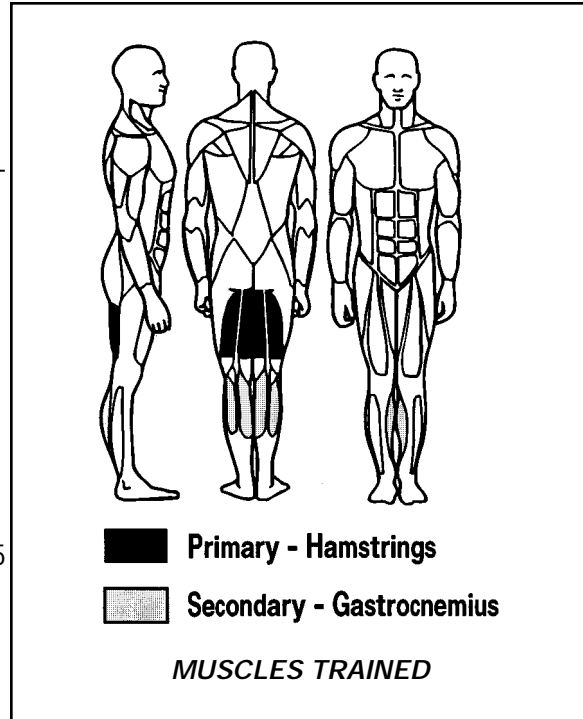

The Positioning

- Note the pivot point at the front right corner of the seat.
- Align the axis of the knees with the pivot point of the machine and adjust the back pad to support the body while maintaining this position.
- Adjust the leg pad to comfort behind the ankles.
- Check the weight to insure the appropriate resistance has been selected. Body position and control of the motion should never be compromised by excessive weight.
- Be seated with the lower leg resting upon the pad.
- Lower the thigh stabilization pad across the quads snugly, making sure that knee axis is also aligned with the machine pivot vertically.
- If the knee does not fully extend while in this position of hip flexion, due to tight hamstrings or other complications, lowering the knee to align with the pivot point will not be possible or safe without adjusting the RLD to allow a start position of slight knee flexion.
- With the ankles against the leg pad, position the legs and feet parallel, ankles neutral and relaxed or slightly plantar flexed.
- Grip the handles on the thigh pad.
- Stabilize the spine with the abdominals to pelvic motion throughout the movement.

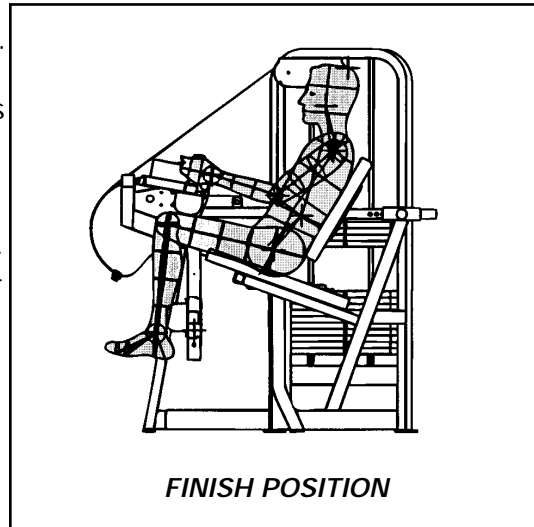
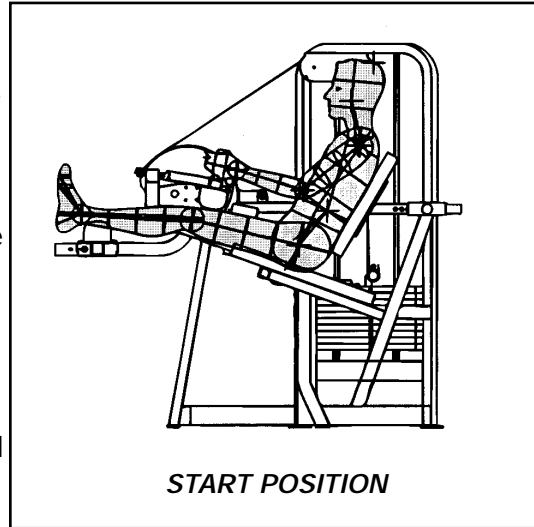

The Motion

- Tighten the hamstrings and smoothly flex the knees as far as possible without moving the pelvis/spine.
- Slowly return near the predetermined position of available extension without resting.
- To exit the machine pull the release button and raise the thigh pad.

The Positioning

- **Set Start Position**

1. Grasp pull pin (pullbutton) and pull.
2. Move input arm to desired position.
3. Lock pull pin into place.

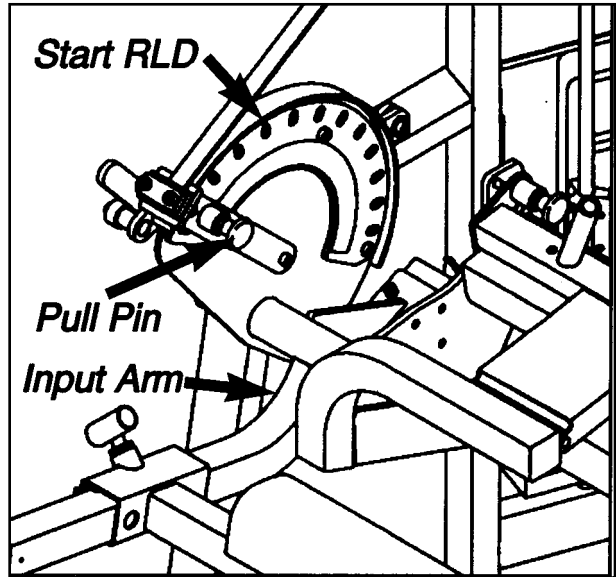

- **Set Stop (End) Position**

1. Grasp pull pin (pullbutton) and pull.
2. Rotate stop to the desired end position.
3. Lock pull pin into place.

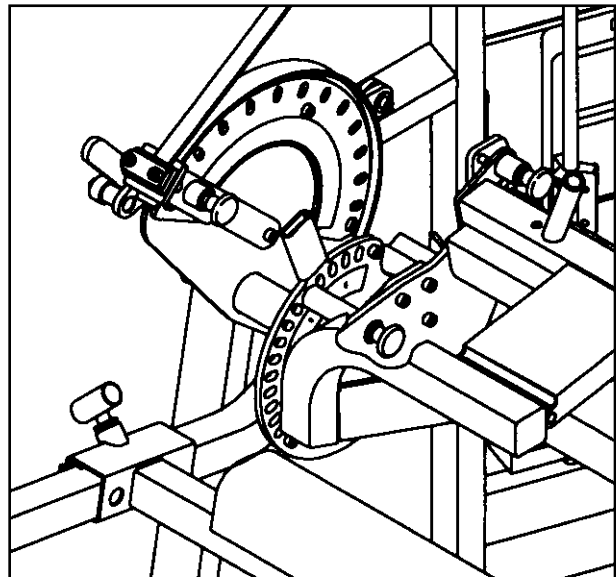

Hip Adduction

The Machine

- **Back Pad** - The back pad is angled to position the hips in 70 degrees of flexion creating both comfort and ease in introducing proper spinal alignment.
- **Variable Resistance** - The cam provides increased resistance at the point in the range where force output of the involved musculature is the greatest.
- **10 to 205 Pounds by Fives** - The top plate provides a minimum weight of ten pounds. Subsequent plates in the weight stack are twenty pounds each. Three "slide-on" five pound incremental plates are securely positioned for easy access and effortless addition thereby providing 10 to 205 pounds in five pound increments.

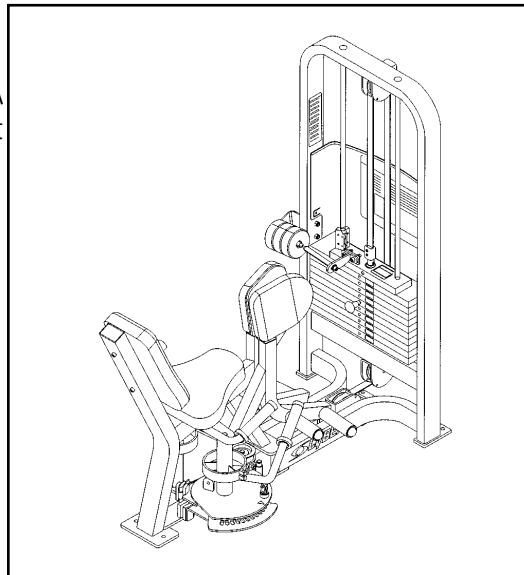

The Abductors

- **Hip Adduction With The Hip Flexed** - The movers of a joint with three degrees of freedom, such as the hip, often change roles or actions depending upon the starting position of the joint. With the hip positioned in 70 degrees of flexion, the adductors magnus, brevis and longus, the gracilis and the pectineus continue to be strong adductors. The hamstrings are weaker associates in this role. The functions of the tensor fasciae latae and gluteus minimus are altered from abductors to adductors due to the degree of hip flexion. Conversely, the obturator internus and quadratus femoris diminish as adductors for the same reason.

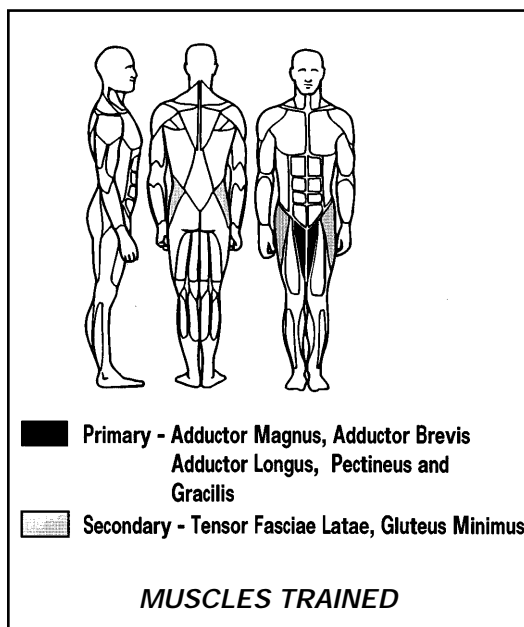

- **Range of Motion** - Hip adduction is limited maximally at 90 degrees within the joint. This is often limited further during active or resisted adduction by muscular insufficiency or by meeting the other extremity at midline. The motion of adduction in a seated position (hip flexed) may begin from a position of extreme abduction in trained individuals (120 - 180) but will commonly be limited to much less due to adductor length (passively and actively) or active insufficiency (resisted eccentrically).

The Positioning

- Use the lever found to the right of the seat to move the knee pads inward to increase ease of positioning.
- Sit on the machine with the feet positioned on the desired foot peg. Choose the peg that allows the thigh to be parallel to the floor.
- Move the knee pads outward to the desired start position. Use of the lever is not required for this adjustment.
- Check the weight to insure that the appropriate resistance has been selected. Body position and control of the motion should never be compromised by excessive weight.
- Grasp the handles lightly.

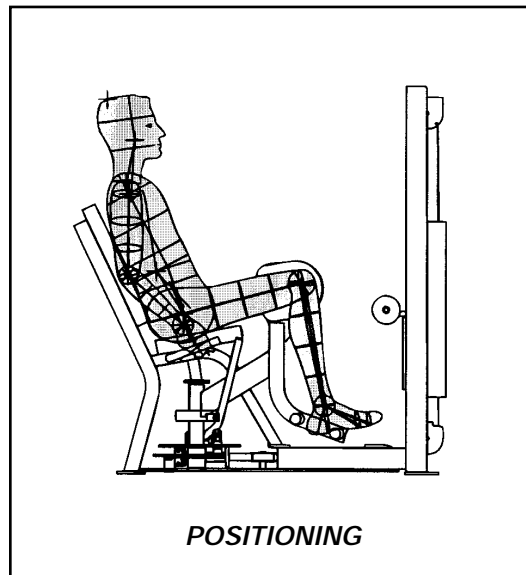

The Motion

- Slowly move the knees toward the center.
- With a smooth controlled motion, slowly return toward the center without resting.
- To exit the machine return the weights to resting position and release the knee pads by pulling the release handle on your right.

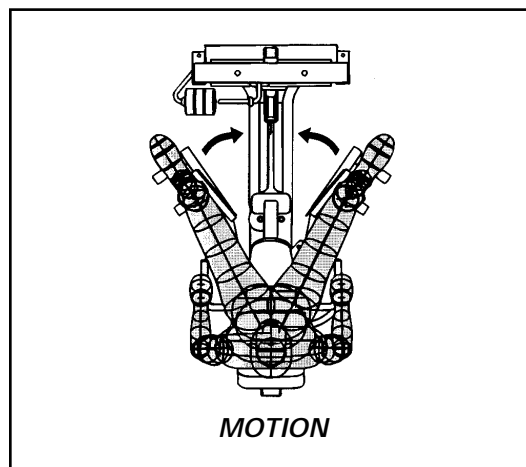

Hip Abduction

The Machine

- **Back Pad** - The back pad is angled to position the hips in 70 degrees of flexion creating both comfort and ease in introducing proper spinal alignment.
- **Variable Resistance** - The cam provides increased resistance at the point in the range where force output of the involved musculature is the greatest.
- **10 to 205 Pounds by Fives** - The top plate provides a minimum weight of ten pounds. Subsequent plates in the weight stack are twenty pounds each. Three "slide-on" five pound incremental plates are securely positioned for easy access and effortless addition thereby providing 10 to 205 pounds in five pound increments.

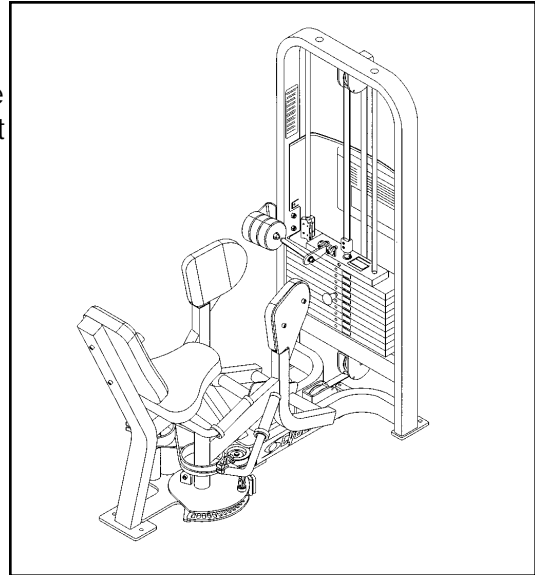

The Abductors

- **Hip Abduction With The Hip Flexed** - The movers of a joint with three degrees of freedom, such as the hip, often change roles or actions depending upon the starting position of the joint. With the hip positioned in 70 degrees of flexion, the gluteus maximus, piriformis and obturator internus are the primary abductors.
- **Range of Motion** - In the erect position "pure" hip abduction can be performed to 45 degrees on each side (90 degrees between the two extremities). However, when the hip is flexed all of the ligaments surrounding the joint are relaxed and additionally, skeletal limitation is eliminated. This may allow as much as 120 to 180 degrees of abduction in trained individuals.

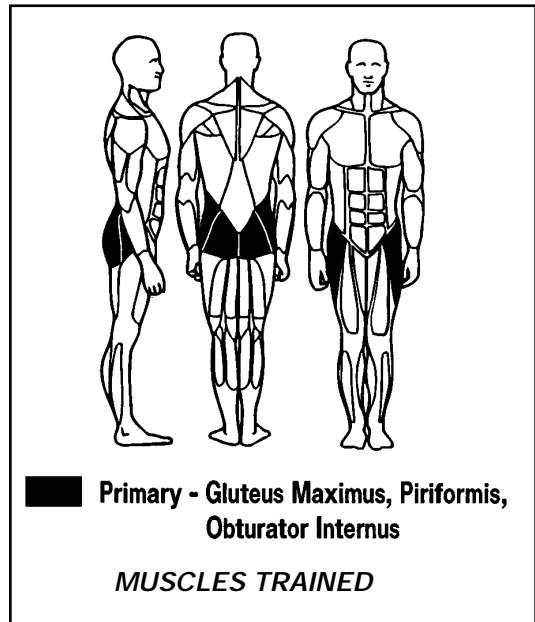

The Positioning

- Use the lever found to the right of the seat to move the knee pads wide enough to allow leg positioning.
- Sit on the machine with the feet positioned on the desired foot peg. Choose the peg that allows the thigh to be parallel to the floor.
- Push the knee pads inward to the desired start position. Use of the lever is not required for this adjustment.
- Check the weight to insure that the appropriate resistance has been selected. Body position and control of the motion should never be compromised by excessive weight.
- Grasp the handles lightly.

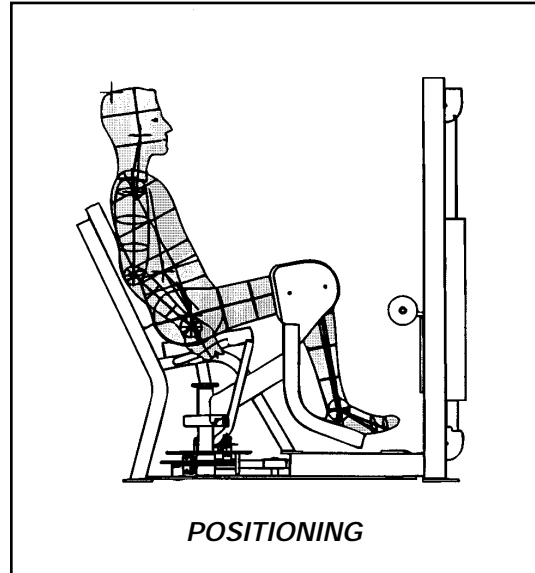

The Motion

- Slowly move the knees apart through a comfortable range.
- With a smooth controlled motion, slowly return toward the center without resting.
- To exit the machine return the weights to resting position and release the knee pads by pulling the release handle on your right.

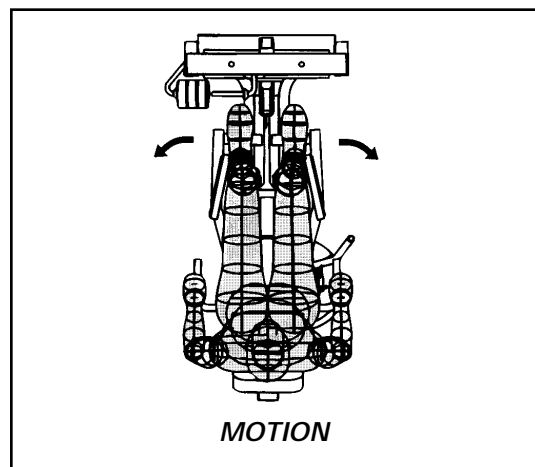

Rotary Calf

The Machine

- **Axis Alignment** - The Rotary Calf machine is designed to match the motion of the ankle joint by aligning the joint axis with a pivot point of the machine.
- **Footplate** - The rotating footplate maintains full and constant contact with the toes and ball of the foot. This increases comfort through greater surface area for weight distribution and increases safety by eliminating the opportunity for the feet to slide off.
- **Variable Resistance** - The machine provides maximum resistance at the beginning of the motion and appropriately decreases the resistance to allow full contraction at the end. No other calf machine varies the resistance throughout the range of motion, allowing each repetition to be completed with a full contraction.
- **10 to 405 Pounds by Fives** - The top plate provides a minimum weight of ten pounds. Subsequent plates in the weight stack are twenty pounds each. Three "slide-on" five pound incremental plates are securely positioned for easy access and effortless addition thereby providing 10 to 405 pounds in five pound increments.

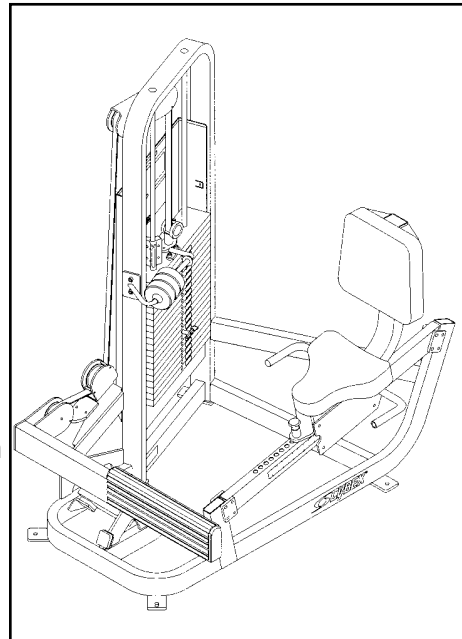

The Calves

- **Ankle Plantar Flexion** - The gastrocnemius and the soleus are responsible for plantar flexion of the ankle joint.
- **Range of Motion** - The ankle permits approximately 60 degrees of active motion. Much more motion is often available during passive movement under load. However, the range of motion during exercise should be limited by the user's ability to control the gastrocnemius and soleus concentrically in plantar flexion and eccentrically in dorsiflexion.
- **Associated Muscles** - The plantaris, peroneus longus and brevis, tibialis posterior, and the flexors of the toes assist with plantar flexion.

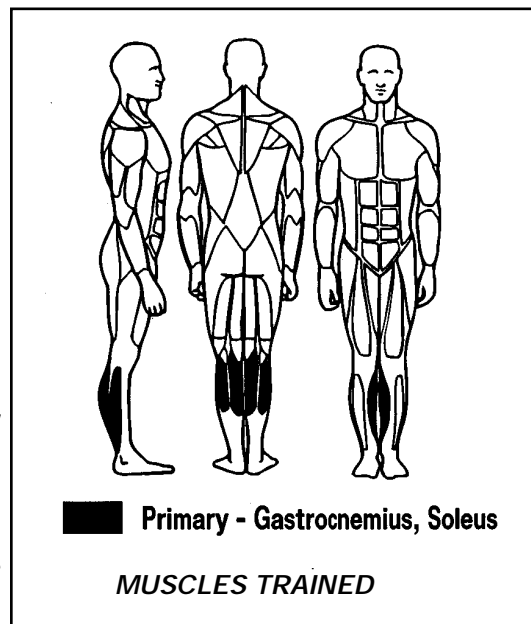

The Positioning

- Adjust the seat, in minor increments, to allow a slight bend or straight knee but not hyperextension.
- Check the weight to insure that the appropriate resistance has been selected. Body position and control of the motion should never be compromised by excessive weight.
- Position the feet parallel at hip width with the ball of each foot securely on the plate (toes near the top of the footplate).

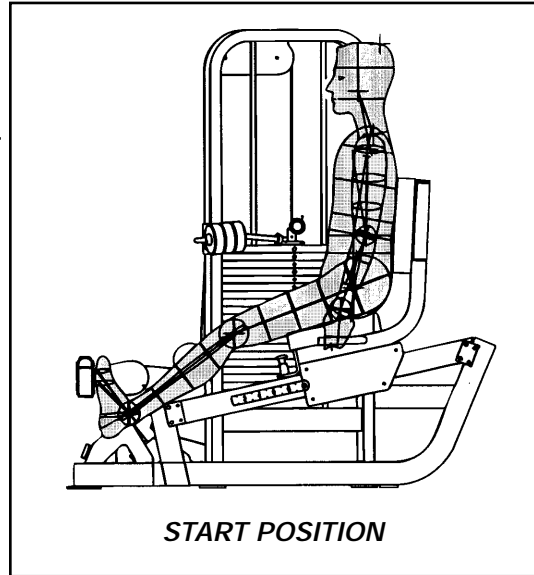

The Motion

- Tighten the calf and press forward as far as possible without moving the knees.
- Return to the starting position without resting and without changing the knee position.
- For more stretch, move the seat forward. For more motion in plantar flexion, move the seat backward.

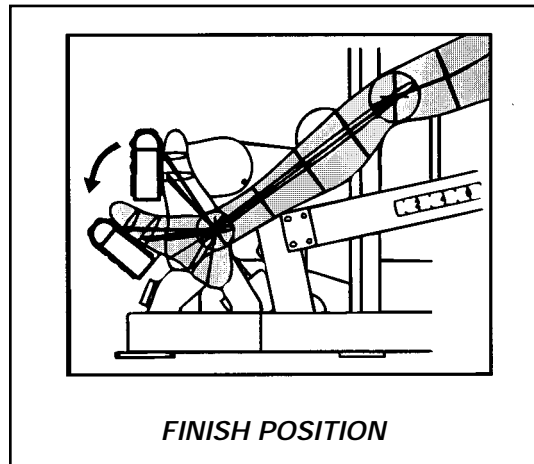

CHAPTER 3 - EXERCISES

Chest Press - Dual Axis

The Machine

- **Range of Motion Adjustment** - The dual-axis chest press eliminates the danger of excessive stretch by providing an adjustable starting position that, when preset to the individual user's structure/mechanics, also serves as a range of motion limit.
- **Plane of Motion** - The handles are angled to allow optimum average wrist position throughout the movement. They are in a "barbell" or horizontal position to encourage motion in the horizontal plane as well as the optimal position of neutral shoulder rotation. Vertical or neutral handles are less effective for chest work as they encourage motion in the sagittal plane (shoulder flexion).
- **User Defined Path of Motion** - The width of the start position, the end position, as well as the path of travel between the two are entirely determined by the user. The path chosen can be based upon the user's ability level, goal, fatigue, or structural limitations (as are often found in the shoulder joint). Options range from the traditional press to numerous other user friendly options including movement toward midline similar to dumbbell exercises. Although the dual-axis technology allows freedom within the proper plane of motion, unwanted motion outside of that plane is safely eliminated by the machine, allowing all effort to be directed toward the Pectoralis Major.
- **Variable Resistance** - A cam provides appropriately varying resistance that is maximal at the end of the motion where the body's mechanical advantage increases.
- **Two Directions of Resistance** - The dual-axis technology not only provides resistance against the pressing movement (by pushing back against you) but it can also provide resistance against adduction (by pushing the hands apart) when the handles are moved inward from their resting position. By providing two directions of resistance within the plane of motion pec stimulation is increased and the triceps are de-emphasized.

NOTE: *Less weight will be employed when the handles are moved inward due to the multiple directions of resistance and the increased muscular effort required of the pectoralis major.*

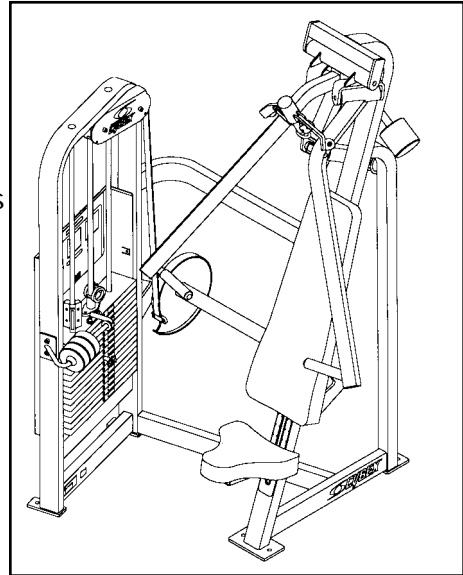

- **10 to 305 Pounds by Fives** - The top plate provides a minimum weight of ten pounds. Subsequent plates in the weight stack are twenty pounds each. Three "slide-on" five pound incremental plates are securely positioned for easy access and effortless addition thereby providing 10 to 305 pounds in five pound increments.

The Chest

- **Horizontal Adduction** - The pectoralis major is primarily responsible for horizontal adduction of the shoulder joint. The pec is also involved in flexion and extension of the shoulder joint, although the anterior deltoid and latissimus dorsi muscles, respectively, are mechanically more effective at performing those motions. The pec is involved in internal rotation of the shoulder, however, this is a mechanically weak motion and becomes the limiting factor in strength when combined with other shoulder motions.
- **Scapular Retraction** - The position of full scapular retraction, when maintained, creates the greatest possible force angles of the pec throughout the range of motion.
- **Range of Motion** - With scapular retraction maintained, horizontal adduction is limited to approximately 90 degrees (arm straight to the front) and horizontal abduction (achieved through the eccentric action "lowering of the weight") is limited by mechanical disadvantage at approximately 0 degrees (upper arm straight out from the shoulder), when pectoralis work is isolated as the goal.
- **Associated Muscles** - The anterior deltoid and coracobrachialis are also prime movers for the motion of horizontal adduction. However, by maintaining motion in the horizontal plane, scapular retraction, and limited horizontal abduction (limited stretch) the pectoralis major will be emphasized over the anterior deltoid. The triceps are always involved in pressing movements as elbow extension is required.

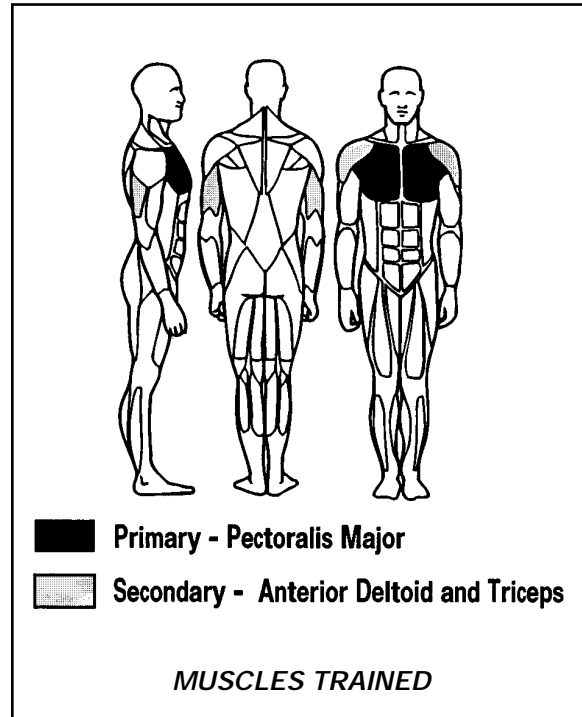

The Positioning

- Adjust the seat to allow the handles to align with the mid-chest. This allows movement through the horizontal plane of the shoulder.
- Adjust the starting position (pull pin found overhead) to allow the upper arm to be straight out to the side when the hands are positioned on the handles.
- Check the weight to insure that the appropriate resistance has been selected. Body position and control of the motion should never be compromised by excessive weight.
- Grip the handles and position the elbows out to the side, level with the handles.
- Fully retract the scapula and maintain on all movements for the chest.

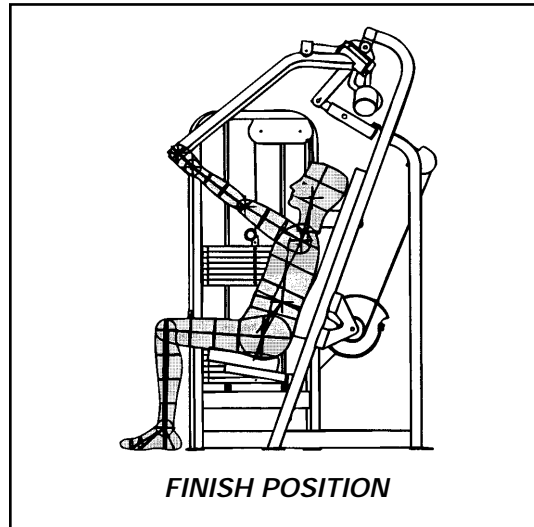
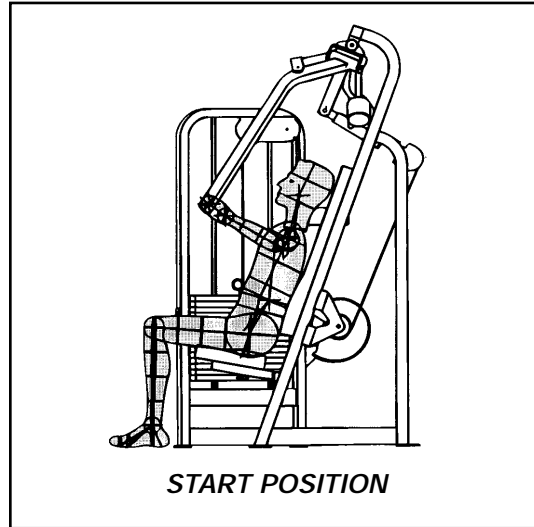

The Motions

IMPORTANT NOTE: *The dual-axis technology is most effective and most comfortable when the following cues are given. These brief instructions, when properly given, improve the motor learning process, which is the key to the safe and effective performance of ANY exercise. After only a few repetitions of each with a light weight the movement will be mastered.*

The Basic Press

- Press the handles forward with a smooth controlled motion and return slowly without resting, keeping the elbows level with the handles and shoulder blades pinched throughout each repetition.

The Adduction

- While in the fully pressed position with the arms straight, move the handles directly toward each other.
- Keeping the arms straight, slowly return the handles to the wide position without resting.

The Advanced Press

- From the wide start position press forward, simultaneously moving the handles toward each other, ending with the arms straight and handles together.
- Return to the wide starting position in a slow controlled manner without resting.

The Stabilization Press

- Before pressing, move the handles inward a few inches and maintain that width while pressing forward and during the return.

NOTE: Each of the above is a valuable exercise within itself and can be used alone or in combinations.

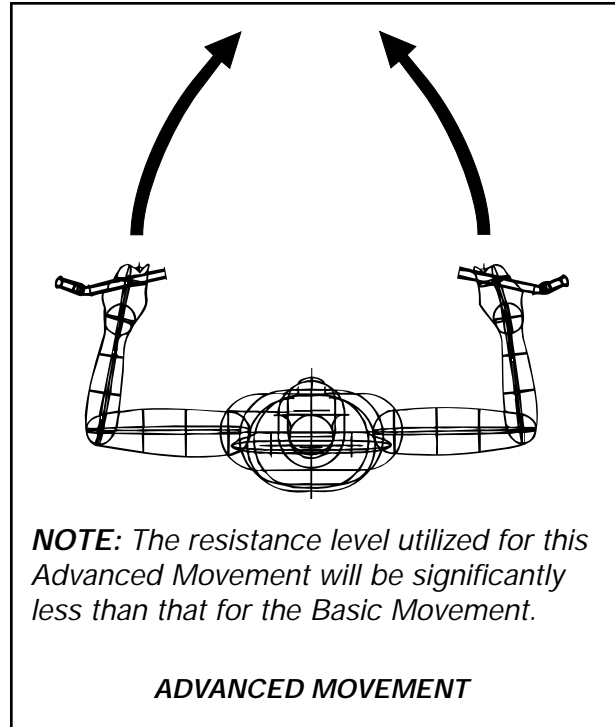

Chest Press - Single Axis

The Machine

- **Range of Motion Adjustment** - The chest press eliminates the danger of excessive stretch by providing an adjustable starting position that, when pre-set to the individual user's structure/mechanics, also serves as a range of motion limit.
- **Plane of Motion** - The handles are angled to allow optimum average wrist position throughout the movement. They are in a "barbell" or horizontal position to encourage motion in the horizontal plane as well as the optimal position of neutral shoulder rotation. Vertical or neutral handles are less effective for chest work as they encourage motion in the sagittal plane (shoulder flexion).
- **Variable Resistance** - A cam provides appropriately varying resistance that is maximal at the end of the motion where the body's mechanical advantage increases.
- **10 to 305 Pounds by Fives** - The top plate provides a minimum weight of ten pounds. Subsequent plates in the weight stack are twenty pounds each. Three "slide-on" five pound incremental plates are securely positioned for easy access and effortless addition thereby providing 10 to 305 pounds in five pound increments.

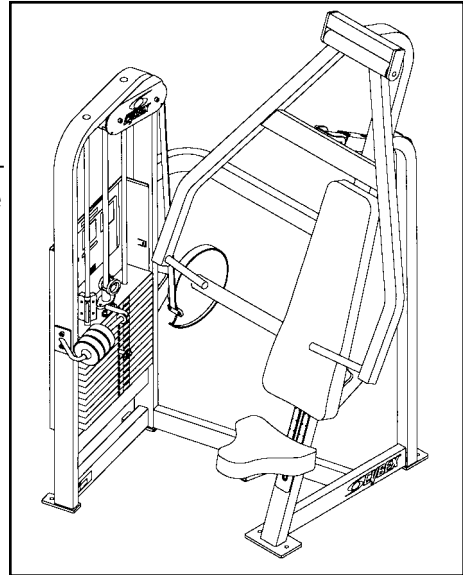

The Chest

- **Horizontal Adduction** - The pectoralis major is primarily responsible for horizontal adduction of the shoulder joint. The pec is also involved in flexion and extension of the shoulder joint, although the anterior deltoid and latissimus dorsi muscles, respectively, are mechanically more effective at performing those motions. The pec is involved in internal rotation of the shoulder, however, this is a mechanically weak motion and becomes the limiting factor in strength when combined with other shoulder motions.
- **Scapular Retraction** - The position of full scapular retraction, when maintained, creates the greatest possible force angles of the pec throughout the range of motion.

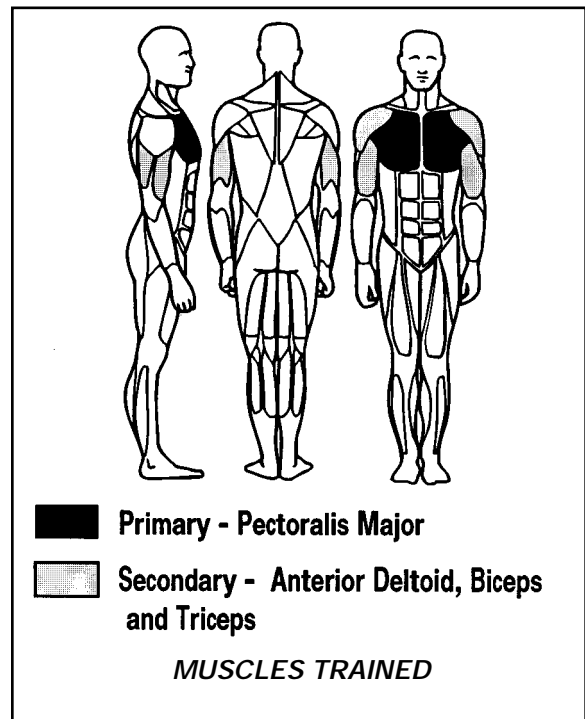

Incline Press - Dual Axis

The Machine

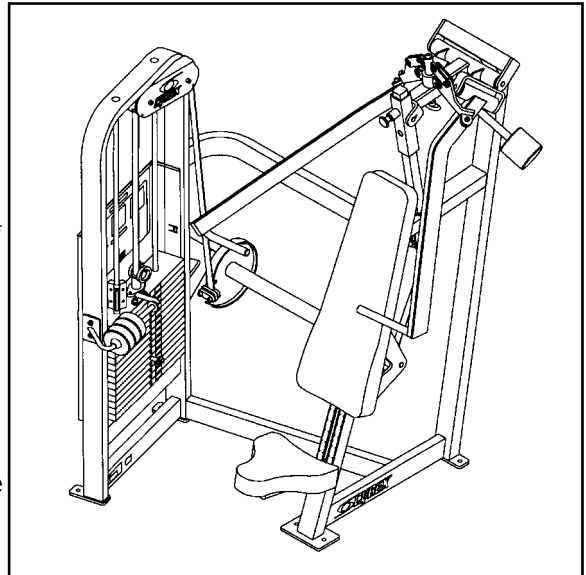

- **Range of Motion Adjustment** - The dual-axis incline press eliminates the danger of excessive stretch by providing an adjustable starting position that, when preset to the individual user's structure/mechanics, also serves as a range of motion limit.
- **Plane of Motion** - The handles move through a very slight arc angled approximately 30 degrees above the plane that lies perpendicular to the bench. (The handles are angled to allow optimum average wrist position throughout the movement.) They are in a "barbell" or horizontal position to encourage shoulder motion through the proper plane as well as the optimal position of neutral shoulder rotation. Vertical or neutral handles are inappropriate for pec work as they encourage motion in the sagittal plane (shoulder flexion).
- **User Defined Path of Motion** - The width of the start position, the end position, as well as the path of travel between the two are entirely determined by the user. The path chosen can be based upon the user's ability level, goal, fatigue, or structural limitations (as are often found in the shoulder joint). Options range from the traditional press to numerous other user friendly options including movement toward midline similar to dumbbell exercises. Although the dual-axis technology allows freedom within the proper plane of motion, unwanted motion outside of that plane is safely eliminated by the machine, allowing all effort to be directed toward the pectoralis major.
- **Variable Resistance** - A cam provides appropriately varying resistance that is maximal at the end of the motion where the body's mechanical advantage increases.
- **Two Directions of Resistance** - The dual-axis technology not only provides resistance against the pressing movement (by pushing back against you) but it can also provide resistance against adduction (by pushing the hands apart) when the handles are moved inward from their resting position. By providing two directions of resistance within the plane of motion pec stimulation is increased and the triceps are de-emphasized.

NOTE: *Less weight will be employed when the handles are moved inward due to the multiple directions of resistance and the increased muscular effort required of the pectoralis major.*

Incline Press - Dual Axis

The Machine

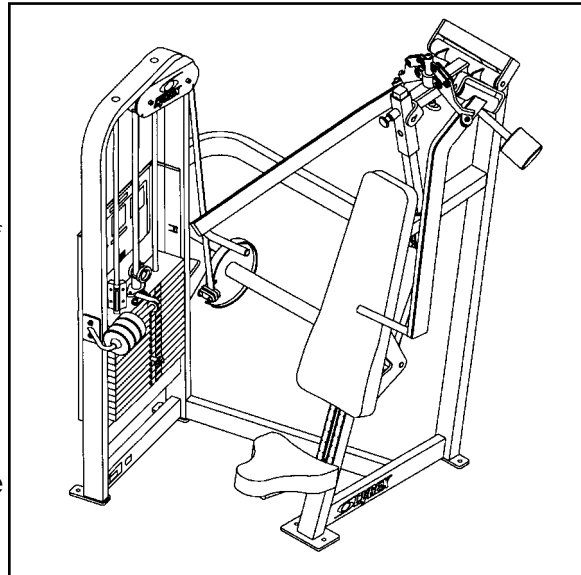

- **Range of Motion Adjustment** - The dual-axis incline press eliminates the danger of excessive stretch by providing an adjustable starting position that, when preset to the individual user's structure/mechanics, also serves as a range of motion limit.
- **Plane of Motion** - The handles move through a very slight arc angled approximately 30 degrees above the plane that lies perpendicular to the bench. (The handles are angled to allow optimum average wrist position throughout the movement.) They are in a "barbell" or horizontal position to encourage shoulder motion through the proper plane as well as the optimal position of neutral shoulder rotation. Vertical or neutral handles are inappropriate for pec work as they encourage motion in the sagittal plane (shoulder flexion).
- **User Defined Path of Motion** - The width of the start position, the end position, as well as the path of travel between the two are entirely determined by the user. The path chosen can be based upon the user's ability level, goal, fatigue, or structural limitations (as are often found in the shoulder joint). Options range from the traditional press to numerous other user friendly options including movement toward midline similar to dumbbell exercises. Although the dual-axis technology allows freedom within the proper plane of motion, unwanted motion outside of that plane is safely eliminated by the machine, allowing all effort to be directed toward the pectoralis major.
- **Variable Resistance** - A cam provides appropriately varying resistance that is maximal at the end of the motion where the body's mechanical advantage increases.
- **Two Directions of Resistance** - The dual-axis technology not only provides resistance against the pressing movement (by pushing back against you) but it can also provide resistance against adduction (by pushing the hands apart) when the handles are moved inward from their resting position. By providing two directions of resistance within the plane of motion pec stimulation is increased and the triceps are de-emphasized.

NOTE: *Less weight will be employed when the handles are moved inward due to the multiple directions of resistance and the increased muscular effort required of the pectoralis major.*

- **10 to 305 Pounds by Fives** - The top plate provides a minimum weight of ten pounds. Subsequent plates in the weight stack are twenty pounds each. Three "slide-on" five pound incremental plates are securely positioned for easy access and effortless addition thereby providing 10 to 305 pounds in five pound increments.

The Chest

- **Modified Plane Adduction** - The clavicular fibers, as well as the upper sternal fibers, of the pectoralis major are primarily responsible for adduction of the shoulder through a plane angled approximately 30 degrees above the horizontal plane of the shoulder joint. The pectoralis major is also involved in flexion and extension of the shoulder joint, although the anterior deltoid and latissimus dorsi muscles, respectively, are mechanically more effective at performing those motions. The pectoralis major is involved in internal rotation of the shoulder, however, this is a mechanically weak motion and becomes the limiting factor in strength when combined with other shoulder motions.
- **Scapular Retraction** - The position of full scapular retraction, when maintained, creates the greatest possible force angles of the pec throughout the range of motion.
- **Range of Motion** - With scapular retraction maintained, horizontal adduction is limited to approximately 90 degrees (arm straight to the front) and horizontal abduction (achieved through the eccentric action "lowering of the weight") is limited by mechanical disadvantage at approximately 0 degrees (upper arm straight out from the shoulder), when pectoralis work is isolated as the goal.
- **Associated Muscles** - The anterior deltoid and coracobrachialis are also prime movers for the motion of horizontal adduction. However, by maintaining motion in the horizontal plane, scapular retraction, and limited horizontal abduction (limited stretch) the pectoralis major will be emphasized over the anterior deltoid. The triceps are always involved in pressing movements as elbow extension is required.

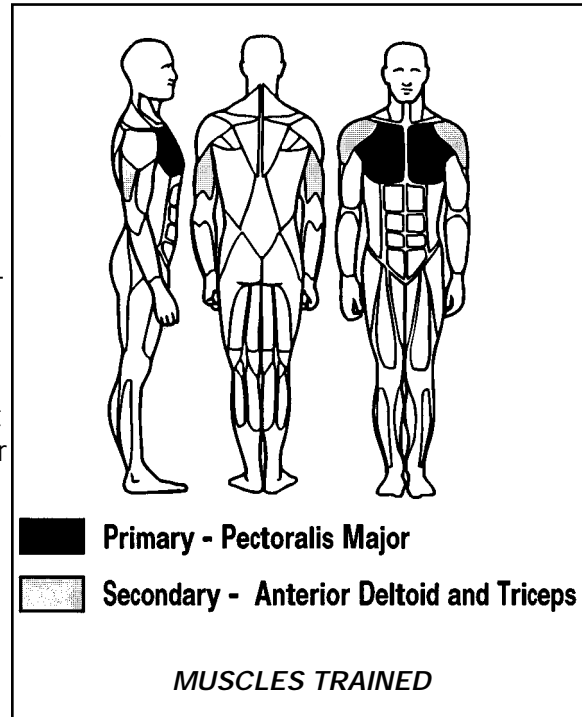

The Positioning

- Adjust the seat to allow the handles to align with the upper chest. This allows movement through the proper plane.
- Adjust the starting position (pull pin found overhead) to allow the upper arm to be straight out to the side when the hands are positioned on the handles.
- Check the weight to insure that the appropriate resistance has been selected. Body position and control of the motion should never be compromised by excessive weight.
- Grip the handles and position the elbows out to the side, level with the handles.
- Fully retract the scapula and maintain on all movements for the chest.

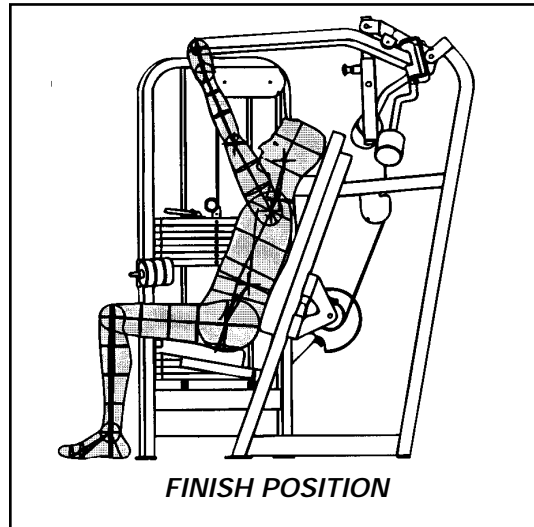
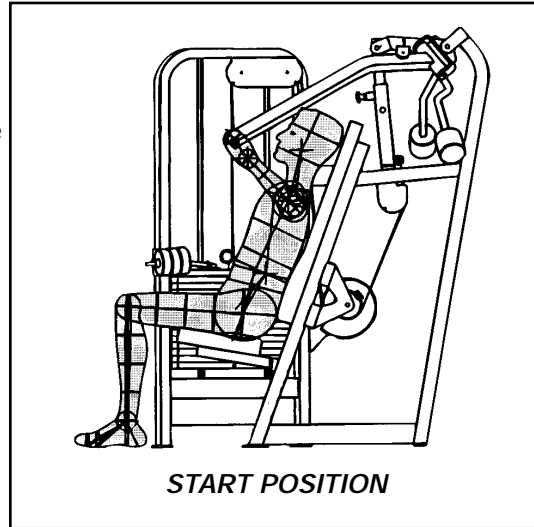

The Motion

IMPORTANT NOTE: *The dual-axis technology is most effective and most comfortable when the following cues are given. These brief instructions, when properly given, improve the motor learning process, which is the key to the safe and effective performance of ANY exercise. After only a few repetitions of each with a light weight the movement will be mastered.*

The Basic Press

- Press the handles forward with a smooth controlled motion and return slowly without resting, keeping the elbows level with the handles and shoulder blades pinched throughout each repetition.

The Adduction

- While in the fully pressed position with the arms straight, move the handles directly toward each other.
- Keeping the arms straight, slowly return the handles to the wide position without resting.

The Advanced Press

- From the wide start position press forward, simultaneously moving the handles toward each other, ending with the arms straight and handles together.
- Return to the wide starting position in a slow controlled manner without resting.

The Stabilization Press

- Before pressing, move the handles inward a few inches and maintain that width while pressing forward and during the return.

NOTE: Each of the above is a valuable exercise within itself and can be used alone or in combinations.

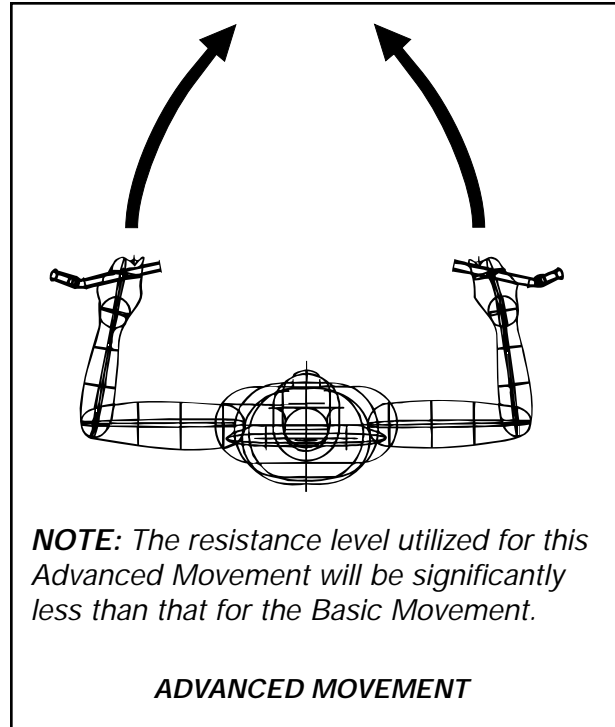

Incline Press - Single Axis

The Machine

- **Range of Motion Adjustment** - The incline press eliminates the danger of excessive stretch by providing an adjustable starting position that, when preset to the individual user's structure/mechanics, also serves as a range of motion limit.
- **Plane of Motion** - The handles move through a very slight arc angled approximately 30 degrees above the plane that lies perpendicular to the bench (horizontal to the body). The handles are angled to allow optimum average wrist position throughout the movement. They are in a "barbell" or horizontal position to encourage shoulder motion through the proper plane as well as the optimal position of neutral shoulder rotation. Vertical or neutral handles are inappropriate for pec work as they encourage motion in the sagittal plane (shoulder flexion).
- **Variable Resistance** - A cam provides appropriately varying resistance that is maximal at the end of the motion where the body's mechanical advantage increases.
- **10 to 305 Pounds by Fives** - The top plate provides a minimum weight of ten pounds. Subsequent plates in the weight stack are twenty pounds each. Three "slide-on" five pound incremental plates are securely positioned for easy access and effortless addition thereby providing 10 to 305 pounds in five pound increments.

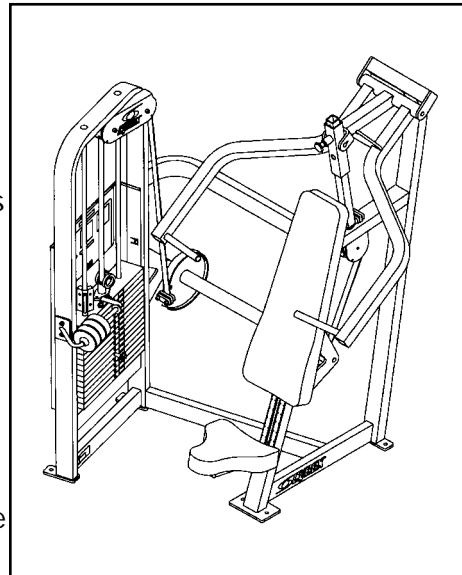

The Chest

- **Angled Horizontal Plane Adduction** - The clavicular fibers, as well as the upper sternal fibers, of the pectoralis major are primarily responsible for adduction of the shoulder through a plane angled approximately 30 degrees above the horizontal plane of the shoulder joint. The pectoralis major is also involved in flexion and extension of the shoulder joint, although the anterior deltoid and latissimus dorsi muscles, respectively, are mechanically more effective at performing those motions. The pectoralis major is involved in internal rotation of the shoulder, however, this is a mechanically weak motion and becomes the limiting factor in strength when combined with other shoulder motions.

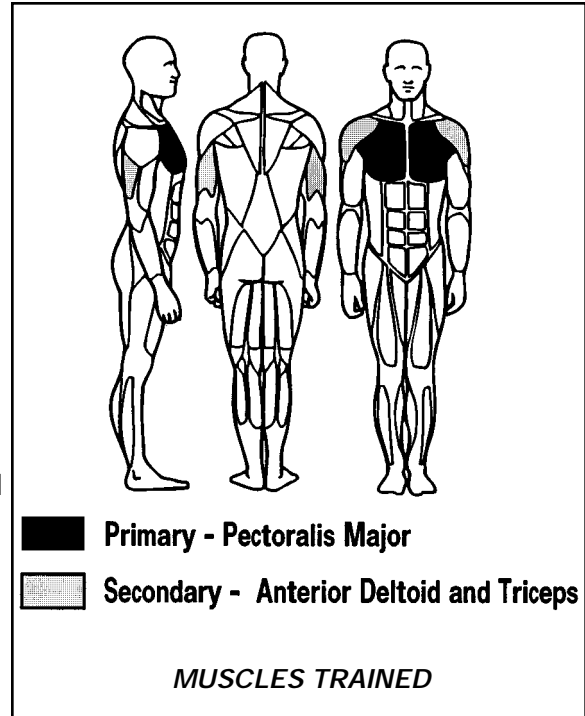

- **Scapular Retraction** - The position of full scapular retraction, when maintained, creates the greatest possible force angles of the pec throughout the range of motion.
- **Range of Motion** - With scapular retraction maintained, horizontal adduction is limited to approximately 90 degrees (arm straight to the front) and horizontal abduction (achieved through the eccentric action "lowering of the weight") is limited by mechanical disadvantage at approximately 0 degrees (upper arm straight out from the shoulder), when pectoralis work is isolated as the goal.
- **Associated Muscles** - The anterior deltoid and coracobrachialis are also prime movers for the motion of horizontal adduction. However, by maintaining motion in the horizontal plane, scapular retraction, and limited horizontal abduction (limited stretch) the pectoralis major will be emphasized over the anterior deltoid. The triceps are always involved in pressing movements as elbow extension is required.

The Positioning

- Adjust the seat to allow the handles to align with the upper chest. This allows movement through the proper plane.
- Adjust the starting position (pull pin found overhead) to allow the upper arm to be straight out to the side when the hands are positioned on the handles.
- Check the weight to insure that the appropriate resistance has been selected. Body position and control of the motion should never be compromised by excessive weight.
- Grip the handles and position the elbows out to the side, level with the handles.
- Fully retract the scapula and maintain on all movements for the chest.

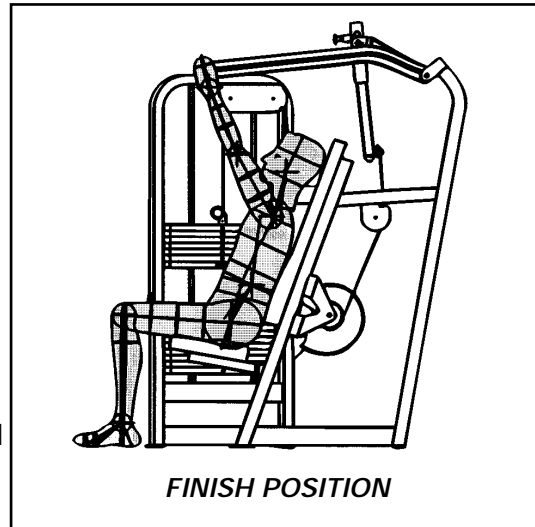
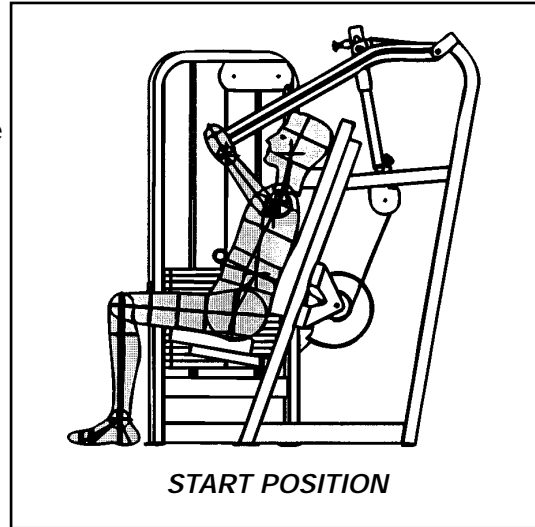

The Motion

- Press the handles forward with a smooth controlled motion and return slowly without resting.
- Maintain the elbows level with the handles and shoulder blades pinched throughout each repetition.

(This page intentionally left blank)

Pulldown - Dual Axis

The Machine

- **Accommodating Grip** - The outer handles pivot to maintain proper wrist alignment throughout the motion of adduction.
 - **Plane of Motion** - The "straight bar"/outer handles allow *full* motion in the frontal plane (adduction). The parallel/narrow handles are specifically designed to allow motion in the sagittal plane (extension). Motion in the sagittal plane (narrow grip pulldown) is considered more functional and safer for the shoulder. The two individual handles allow the user to pull through the center of the body or through the front. The detrimental and minimally effective "behind the neck" position should be avoided by leaning back slightly.
 - **Range of Motion** - The dual-axis technology allows a greater range of motion in the frontal plane (wide pulldown) than any other machine by allowing the user to start directly overhead and move outward, then down, then in toward the sides. The user also has the ability to perform a narrow grip pulldown of varying widths ranging from several inches to shoulder width.
 - **Variable Resistance** - The machine provides maximum resistance at the beginning of motion and appropriately decreases the resistance to allow full contraction at the end.
 - **Two Directions of Resistance** - The dual-axis technology functions in the wide grip pulldown to not only provide resistance against the downward movement (by pulling upward against you) but also to provide resistance against the outward motion at the top of the wide movement (by pushing the hands together). By providing two directions of resistance within the frontal plane latissimus stimulation is increased and the elbow flexors are de-emphasized.
- NOTE:** Less weight will be employed when the handles are moved outwards due to the multiple directions of resistance and the increased muscular effort required of the lats.*
- **10 to 305 Pounds by Fives** - The top plate provides a minimum weight of ten pounds. Subsequent plates in the weight stack are twenty pounds each. Three "slide-on" five pound incremental plates are securely positioned for easy access and effortless addition thereby providing 10 to 305 pounds in five pound increments.

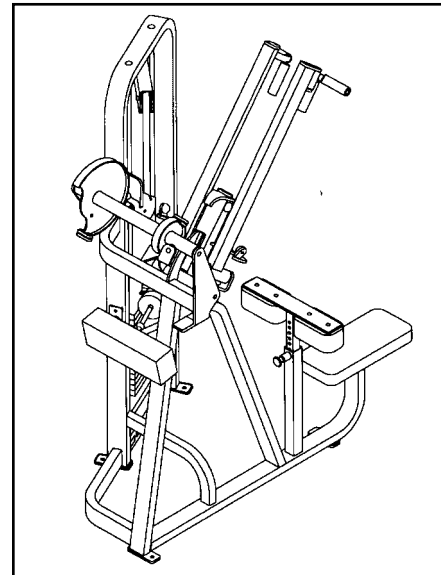

The Latissimus Dorsi

- **Extension/Adduction** - The latissimus dorsi is responsible for extension as well as adduction of the shoulder joint. The lat is also involved in internal rotation of the shoulder, however, this is a mechanically weak motion and becomes the limiting factor in strength when combined with other motions. The teres major works alongside the upper fibers of the lat in adduction and extension. The combined positions of external rotation to 90 degrees and abduction to 90 degrees create the most compromising position for the shoulder joint.
- **Range of Motion** - Full normal adduction or extension begins with the arm in a vertical position overhead at 180 degrees and ends with the arm at the side in 0 degrees. As the arm moves from overhead the direction of travel arcs outward (for adduction) or forward (for extension) away from the head, then down, and finally, inward toward the side. Full concentric shortening of the lat can only occur when the associated scapular motion is performed with shoulder motion. With motion and resistance from overhead, scapular depression is required. For the arm to return to the starting position overhead the eccentric action of the lat must be accompanied by the scapular rotation of scapulohumeral rhythm.
- **Associated Muscles** - The lower fibers of the trapezius are responsible for scapular depression. Slight retraction is always associated with scapular depression as the lower fibers of the trapezius angle downward and toward midline, attaching on the spine. The long head of the triceps is involved in shoulder extension and adduction, although change in its length is limited when elbow flexion coincides with shoulder motion. The biceps, brachioradialis, and brachialis are always involved in pulling movements as elbow flexion is required. The degree of their individual involvement depends upon radioulnar joint position.

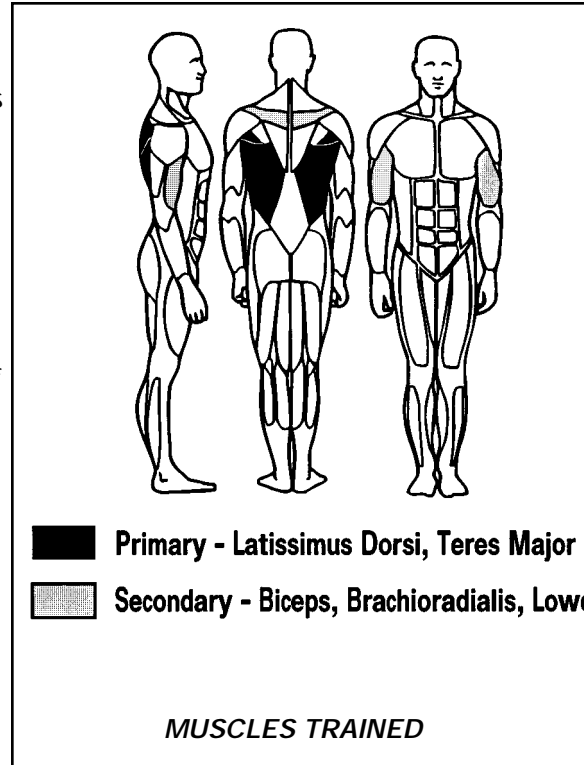

The Positioning

- Adjust the thigh pad to allow access and stabilize the body.
- Check the weight to insure that the appropriate resistance has been selected. Body position and control of the motion should never be compromised by excessive weight.

The Motions

The Narrow Pulldown

NOTE: This exercise is ideal for the beginner as well as being the safest (biomechanically correct), most functional, and optimally effective for the advanced user.

- Grip the narrow/parallel handles.
- Lean back slightly at the hips and maintain. Watch the handles to insure that they safely clear the head on the way down.
- Depress the scapula (pinch the shoulder blades down and back).
- While maintaining the scapular position, bring the handles toward the chest and arms down beside the body.
- Slowly return to the starting position overhead by allowing the scapula to move as needed, but without resting.
- Reset the scapula at the beginning of each repetition.

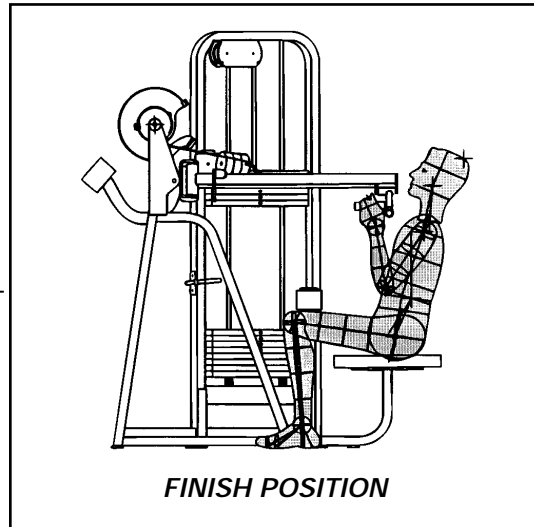
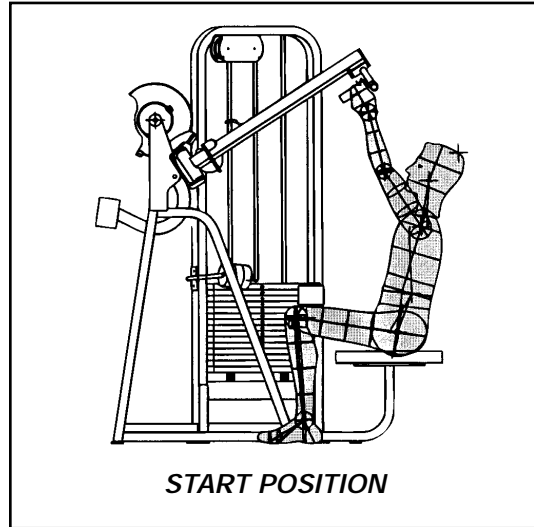

IMPORTANT NOTE: The dual-axis technology is most effective and most comfortable when the following cues are given. These brief instructions, when properly given, improve the motor learning process, which is the key to the safe and effective performance of ANY exercise. After only a few repetitions of each with a light weight the movement will be mastered.

The Wide Pulldown

- Grip the outer handles and lean back slightly at the hips.
- Depress the scapula (pinch the shoulder blades down and back).
- Move the handles outward first, then bring the arms down fully to your sides. Keep the elbows *directly beneath* the hands throughout the entire range of motion.
- Slowly return to the starting position overhead by allowing the scapula to move as needed, but maintaining lateral resistance by not touching the handles together at the top.

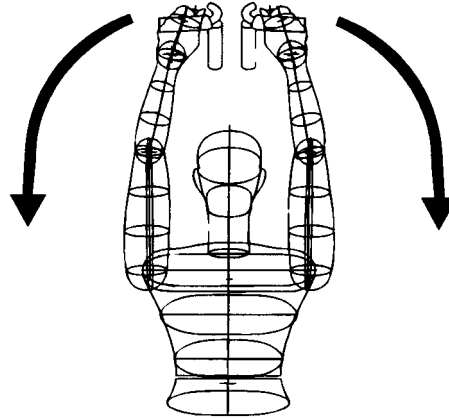

NOTE: The resistance level utilized for this Advanced Movement will be significantly less than that for the Basic Movement.

ADVANCED MOVEMENT

Row / Rear Delt - Dual Axis

The Machine

- **Planes of Motion** - The long parallel or vertical handles are specifically designed to allow motion in the sagittal plane (extension). The horizontal handles allow *full* motion in the horizontal plane for optimum posterior deltoid (rear delt) work. The length/position of the handles allows use of either set from the same seat position.
 - **Range of Motion** - The dual-axis technology allows a greater range of motion in the horizontal plane (rear delt) than any other machine by allowing the user to start directly in front and move outward, then back.
 - **Variable Resistance** - The machine provides maximum resistance at the beginning of motion and appropriately decreases the resistance to allow full contraction at the end.
 - **Two Directions of Resistance** - The dual-axis technology is used in the rear delt movement to not only provide resistance against the backward movement (by pulling forward against you) but also to provide resistance against the outward motion that is optimal at the beginning of the movement (by pushing the hands together). By providing two directions of resistance within the horizontal plane of motion posterior deltoid stimulation is increased and the elbow flexors are de-emphasized.
- NOTE:** Less weight will be employed when the handles are moved outward due to the multiple directions of resistance and the increased muscular effort required of the rear delts.*
- **10 to 305 Pounds by Fives** - The top plate provides a minimum weight of ten pounds. Subsequent plates in the weight stack are twenty pounds each. Three "slide-on" five pound incremental plates are securely positioned for easy access and effortless addition thereby providing 10 to 305 pounds in five pound increments.

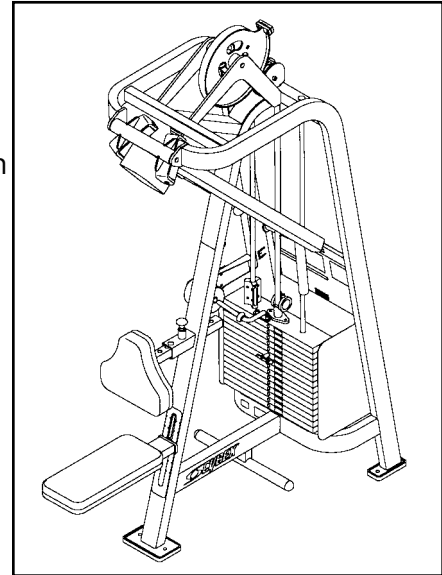

The Latissimus Dorsi

- **Extension** - The latissimus dorsi is responsible for extension as well as adduction of the shoulder joint. This machine is designed to resist shoulder extension from the front. The lat is also involved in internal rotation of the shoulder, however, this is a mechanically weak motion and becomes the limiting factor in strength when combined with other motions. The teres major works alongside the upper fibers of the lat in extension.
- **Range of Motion** - Row/extension begins with the arm positioned forward (shoulder joint in approximately 90 degrees of flexion) and ends with the arm at the side in 0 degrees. Full concentric shortening of the lat can only occur when the associated scapular motion is performed with the shoulder motion. With motion and resistance from the front, scapular retraction is required. For the arm to return to the starting position, scapular motion is not required. However, if protraction is allowed during the eccentric phase, then the scapula must be reset in retraction at the beginning of the next repetition.
- **Associated Muscles** - The rhomboids and middle fibers of the trapezius are responsible for scapular retraction. The posterior deltoid is an assistant mover for shoulder extension. The long head of the triceps is also involved in shoulder extension, although change in its length is limited when elbow flexion coincides with shoulder motion. The biceps, brachioradialis, and brachialis are always involved in pulling movements as elbow flexion is required. The degree of their individual involvement depends upon radioulnar joint position.

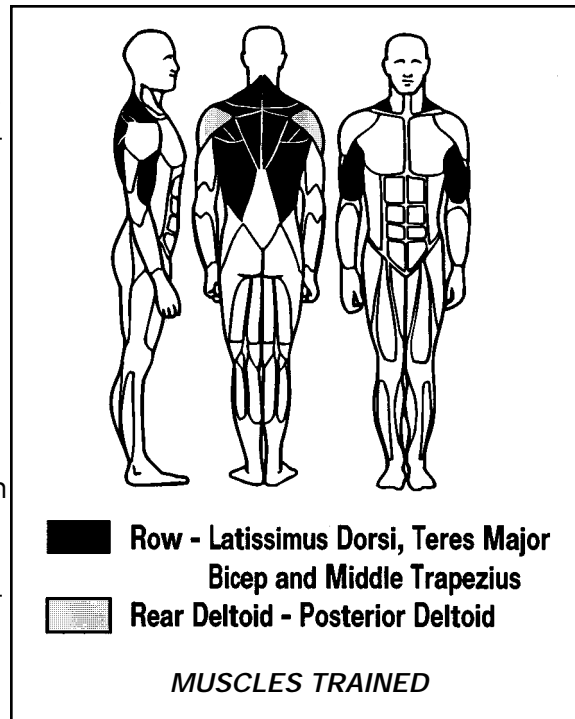

The Posterior Deltoid

- **Horizontal Abduction** - The posterior deltoid is responsible for horizontal abduction of the shoulder joint. Due to the attachment of the rear deltoid on the scapula, the scapula must remain stabilized during shoulder joint motion. If scapular movement occurs, the resistance will move without change in the length of the rear delt, minimizing effectiveness. The teres minor and infraspinatus are also prime movers for horizontal abduction.
- **Range of Motion** - Horizontal abduction is limited concentrically at approximately 10 - 20 degrees (posterior to the shoulder) and eccentrically at approximately 90 degrees of horizontal adduction (arms to the front) when the scapula remains retracted. From the starting position in front, the arms move outward then back at shoulder level as the concentric action is performed.

CYBEX VR2 Owner's Manual

- **Associated Muscles** - The rhomboids and middle fibers of the trapezius are responsible for stabilization of the scapula in retraction. The teres major and upper fibers of the latissimus dorsi are assistant movers for horizontal abduction. The biceps, brachioradialis, and brachialis are always involved in pulling movements as elbow flexion is required. The degree of their individual involvement depends upon radioulnar joint position.

The Positioning

- Adjust the seat to align the horizontal handles with the top of the shoulders.
- Adjust the chest pad to allow both hands to reach the handles while protracting. Moving into the "chest up" erect posture should then allow full motion.
- Check the weight to insure that the appropriate resistance has been selected. Body position and control of the motion should never be compromised by excessive weight.

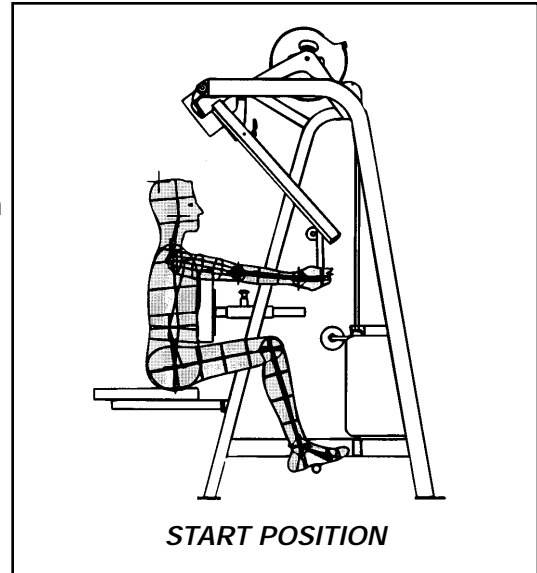

The Motion - The Row

- Grip the lower end of the vertical or parallel handles.
- Retract the scapula (pinch the shoulder blades back and together).
- While maintaining the scapular position and the chest on the pad, bring the arms to your sides.
- Slowly return to the starting position without resting.
- If the scapular position changes, reset the scapula retraction at the beginning of each repetition.

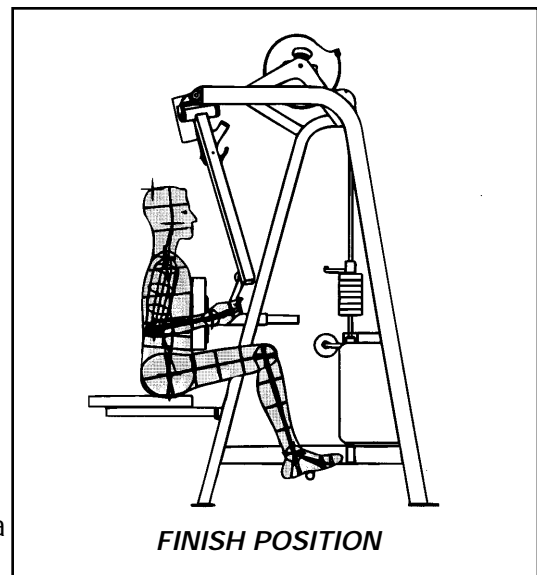

IMPORTANT NOTE: The dual-axis technology is most effective and most comfortable when the following cues are given. These brief instructions, when properly given, improve the motor learning process, which is the key to the safe and effective performance of ANY exercise. After only a few repetitions of each with a light weight will the movement be mastered.

The Motion - The Rear Delt

- Grip the horizontal handles.
- Retract the scapula (pinch the shoulder blades back and together) and maintain.
- Move the handles outward, then bend the arms and bring the elbows back as far as possible, keeping them at shoulder level. "Lead with the elbows" to decrease elbow flexor involvement.
- Slowly return to the starting position without resting, maintaining scapular retraction.

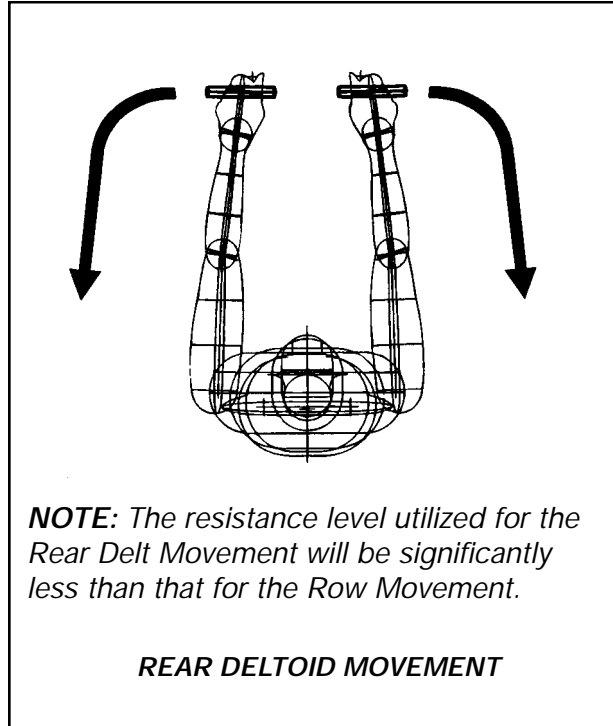

Row / Rear Delt - Single Axis

The Machine

- **Planes of Motion** - The long parallel or vertical handles are specifically designed to allow motion in the sagittal plane (extension). The horizontal handles allow *full* motion in the horizontal plane for optimum posterior deltoid (rear delt) work. The length/position of the handles allows use of either set from the same seat position.
- **Variable Resistance** - The machine provides maximum resistance at the beginning of motion and appropriately decreases the resistance to allow full contraction at the end.
- **10 to 305 Pounds by Fives** - The top plate provides a minimum weight of ten pounds. Subsequent plates in the weight stack are twenty pounds each. Three "slide-on" five pound incremental plates are securely positioned for easy access and effortless addition thereby providing 10 to 305 pounds in five pound increments.

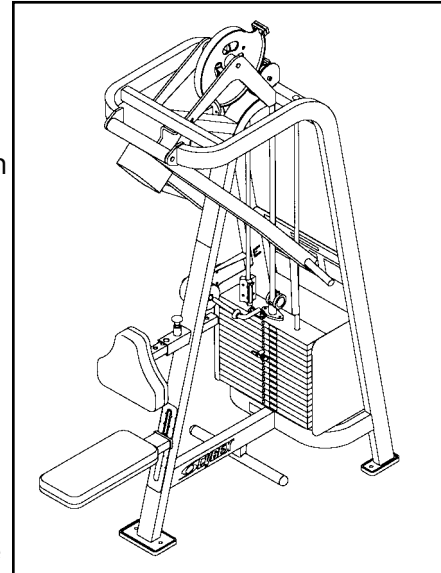

The Latissimus Dorsi

- **Extension** - The latissimus dorsi is responsible for extension as well as adduction of the shoulder joint. This machine is designed to resist shoulder extension from the front. The lat is also involved in internal rotation of the shoulder, however, this is a mechanically weak motion and becomes the limiting factor in strength when combined with other motions. The teres major works alongside the upper fibers of the lat in extension.
- **Range of Motion** - Row/extension begins with the arm positioned forward (shoulder joint in approximately 90 degrees of flexion) and ends with the arm at the side in 0 degrees. Full concentric shortening of the lat can only occur when the associated scapular motion is performed with the shoulder motion. With motion and resistance from the front, scapular retraction is required. For the arm to return to the starting position, scapular motion is not required. However, if protraction is allowed during the eccentric phase, then the scapula must be reset in retraction at the beginning of the next repetition.

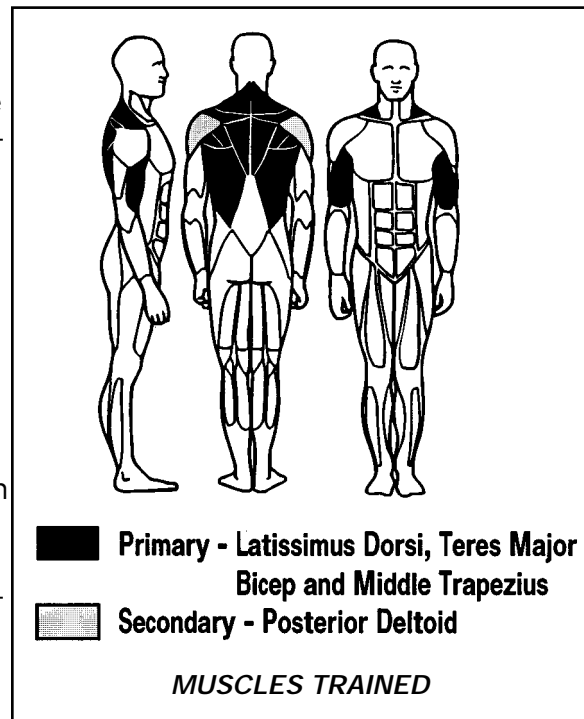

CYBEX VR2 Owner's Manual

- **Associated Muscles** - The rhomboids and middle fibers of the trapezius are responsible for scapular retraction. The posterior deltoid is an assistant mover for shoulder extension. The long head of the triceps is also involved in shoulder extension, although change in its length is limited when elbow flexion coincides with shoulder motion. The biceps, brachioradialis, and brachialis are always involved in pulling movements as elbow flexion is required. The degree of their individual involvement depends upon radioulnar joint position.

The Posterior Deltoid

- **Horizontal Abduction** - The posterior deltoid is responsible for horizontal abduction of the shoulder joint. Due to the attachment of the rear deltoid on the scapula, the scapula must remain stabilized during shoulder joint motion. If scapular movement occurs, the resistance will move without change in the length of the rear delt, minimizing effectiveness. The teres minor and infraspinatus are also prime movers for horizontal abduction.
- **Range of Motion** - Horizontal abduction is limited concentrically at approximately 10 - 20 degrees (posterior to the shoulder) and eccentrically at approximately 90 degrees of horizontal adduction (arms to the front) when the scapula remains retracted.
- **Associated Muscles** - The rhomboids and middle fibers of the trapezius are responsible for stabilization of the scapula in retraction. The teres major and upper fibers of the latissimus dorsi are assistant movers for horizontal abduction. The biceps, brachioradialis, and brachialis are always involved in pulling movements as elbow flexion is required. The degree of their individual involvement depends upon radioulnar joint position.

The Positioning

- Adjust the seat to align the horizontal handles with the top of the shoulders.
- Adjust the chest pad to allow both hands to reach the handles while protracting. Moving into the "chest up" erect posture should then allow full motion.
- Check the weight to insure that the appropriate resistance has been selected. Body position and control of the motion should never be compromised by excessive weight.

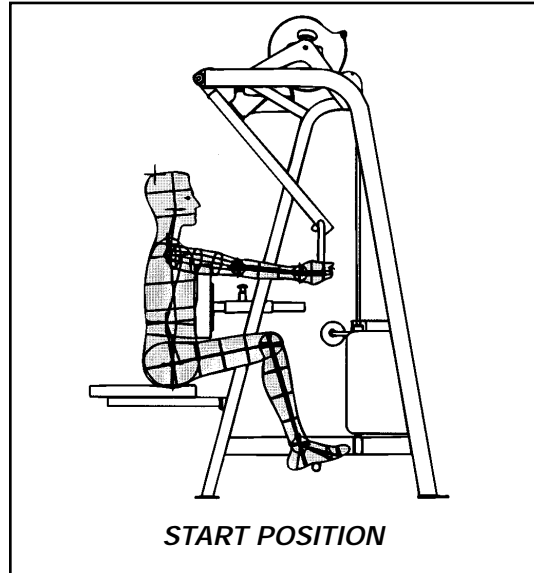

The Motion - The Row

- Grip the lower end of the vertical or parallel handles.
- Retract the scapula (pinch the shoulder blades back and together).
- While maintaining the scapular position and the chest on the pad, bring the arms to your sides.
- Slowly return to the starting position without resting.
- If the scapular position changes, reset the scapula retraction at the beginning of each repetition.

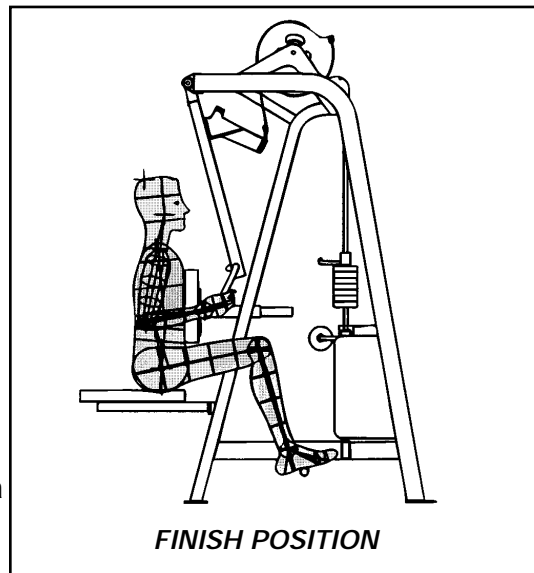

The Motion - The Rear Delt

- Grip the horizontal handles.
- Retract the scapula (pinch the shoulder blades back and together) and maintain.
- Bring the elbows back as far as possible, keeping them at shoulder level. "Lead with the elbows" to decrease elbow flexor involvement.
- Slowly return to the starting position without resting, maintaining scapular retraction.

Overhead Press - Dual Axis

The Machine

- **Range of Motion Adjustment** - The seat adjustment of the dual-axis overhead press serves to determine start position and as a range of motion limit.
- **Plane of Motion** - The handles are angled to allow optimum average wrist position throughout the movement. The "barbell" or horizontal position encourages motion in the frontal plane (abduction). The neutral or parallel handles encourage motion in the sagittal plane (flexion). Motion in the sagittal plane (pressing in the front) is considered more functional and safer for the overhead press and is just as (if not more) effective for stimulation of the desired muscles.
- **Variable Resistance** - A cam provides appropriately varying resistance that is maximal at the end of the motion where the body's mechanical advantage increases.
- **User Defined Path of Motion** - The width of the start position, the end position, as well as the path of travel between the two are entirely determined by the user. The path chosen can be based upon the user's ability level, goal, fatigue, or structural limitations (as are often found in the shoulder joint). Options range from the traditional press to numerous other user friendly options including movement toward midline similar to dumbbell exercises. Although the dual-axis technology allows freedom within the proper plane of motion, unwanted motion outside of that plane is safely eliminated by the machine, allowing all effort to be directed toward the deltoids. This freedom is ideal for those users who have special limitations or discomfort with traditional press machines as they are able to select a pain free and unrestricted path of travel.
- **Two Directions of Resistance** - The dual-axis technology not only provides resistance against the pressing movement (by pushing down against you) but it can also provide resistance against the inward motion at the top (by pushing the hands apart). By providing two directions of resistance within the plane of motion deltoid stimulation is increased and the triceps are de-emphasized.

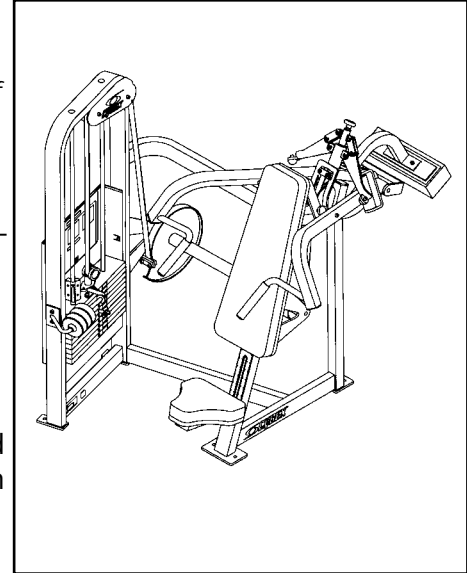

NOTE: *Less weight will be employed when the handles are moved inward due to the multiple directions of resistance and the increased muscular effort required of the deltoids.*

Overhead Press - Dual Axis

The Machine

- **Range of Motion Adjustment** - The seat adjustment of the dual-axis overhead press serves to determine start position and as a range of motion limit.
- **Plane of Motion** - The handles are angled to allow optimum average wrist position throughout the movement. The "barbell" or horizontal position encourages motion in the frontal plane (abduction). The neutral or parallel handles encourage motion in the sagittal plane (flexion). Motion in the sagittal plane (pressing in the front) is considered more functional and safer for the overhead press and is just as (if not more) effective for stimulation of the desired muscles.
- **Variable Resistance** - A cam provides appropriately varying resistance that is maximal at the end of the motion where the body's mechanical advantage increases.
- **User Defined Path of Motion** - The width of the start position, the end position, as well as the path of travel between the two are entirely determined by the user. The path chosen can be based upon the user's ability level, goal, fatigue, or structural limitations (as are often found in the shoulder joint). Options range from the traditional press to numerous other user friendly options including movement toward midline similar to dumbbell exercises. Although the dual-axis technology allows freedom within the proper plane of motion, unwanted motion outside of that plane is safely eliminated by the machine, allowing all effort to be directed toward the deltoids. This freedom is ideal for those users who have special limitations or discomfort with traditional press machines as they are able to select a pain free and unrestricted path of travel.
- **Two Directions of Resistance** - The dual-axis technology not only provides resistance against the pressing movement (by pushing down against you) but it can also provide resistance against the inward motion at the top (by pushing the hands apart). By providing two directions of resistance within the plane of motion deltoid stimulation is increased and the triceps are de-emphasized.

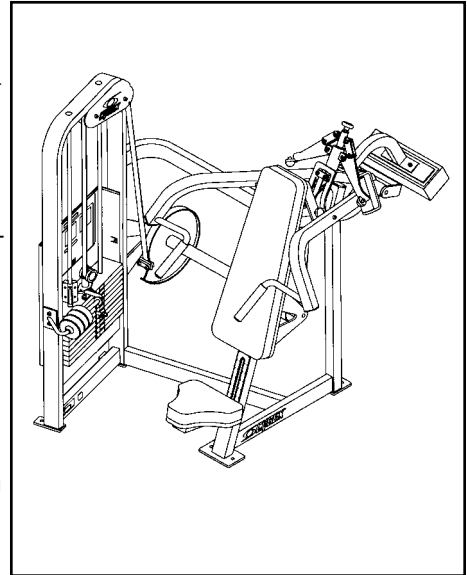

NOTE: *Less weight will be employed when the handles are moved inward due to the multiple directions of resistance and the increased muscular effort required of the deltoids.*

CYBEX VR2 Owner's Manual

- **10 to 205 Pounds by Fives** - The top plate provides a minimum weight of ten pounds. Subsequent plates in the weight stack are twenty pounds each. Three "slide-on" five pound incremental plates are securely positioned for easy access and effortless addition thereby providing 10 to 205 pounds in five pound increments.

The Shoulders

- **Flexion/Abduction in External Rotation** - The anterior deltoid is primarily responsible for flexion of the shoulder joint as well as abduction of the shoulder joint when combined with 90 degrees of external rotation (overhead press position). The middle deltoid is a prime mover for shoulder abduction, however, its level of involvement diminishes as the shoulder is externally rotated and the middle fibers are moved posteriorly. The actual degree of middle deltoid involvement varies with the user's individual deltoid structure. The combined positions of external rotation to 90 degrees and abduction to 90 degrees create the most compromising position for the shoulder joint.

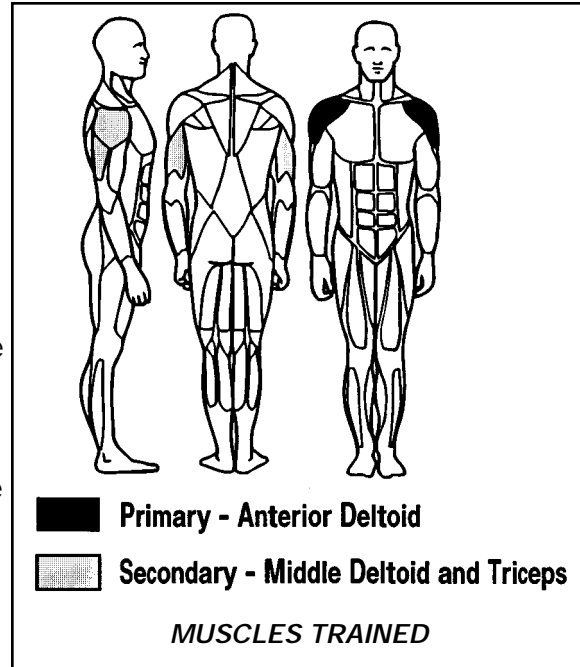

- **Range of Motion** - Full normal abduction or flexion begins with the arm at the side in 0 degrees and ends in a vertical position overhead at 180 degrees. As the arm moves overhead the direction of travel arcs upward, then inward toward the head.
- **Associated Muscles** - Collectively, the scapular muscles are involved in the scapular rotation that is key to scapulohumeral rhythm. This combined motion of the scapula and the shoulder joint is required to achieve elevation of the arm overhead in any plane. The rotator cuff muscles act as dynamic stabilizers during elevation of the arm. The triceps are always involved in pressing movements as elbow extension is required. Due to the externally rotated position, the posterior deltoid plays a stabilizing role at best and in many shoulder structures would prove to be an antagonist to overhead movements.

The Positioning

- Adjust the seat to align the handles with the top of the shoulders.
- Check the weight to insure that the appropriate resistance has been selected. Body position and control of the motion should never be compromised by excessive weight.
- Grip either set of handles and position the elbows directly below the hands.

The Motions

IMPORTANT NOTE: The dual-axis technology is most effective and most comfortable when the following cues are given. These brief instructions, when properly given, improve the motor learning process, which is the key to the safe and effective performance of ANY exercise. After only a few repetitions of each with a light weight the movement will be mastered.

The Basic Press

- Press the handles upward with a smooth controlled motion and return slowly without resting, keeping the elbows directly below the hands at the bottom of each repetition.

The Overhead Fly

- While in the fully pressed position with the arms straight, move the handles directly toward each other.
- While keeping the arms straight, slowly return the handles to the wide position without resting.

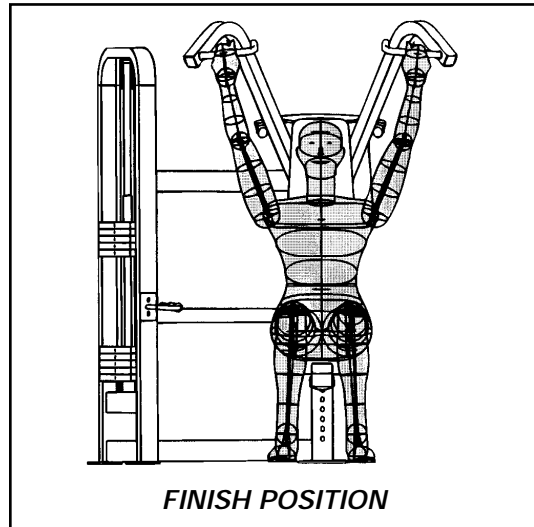
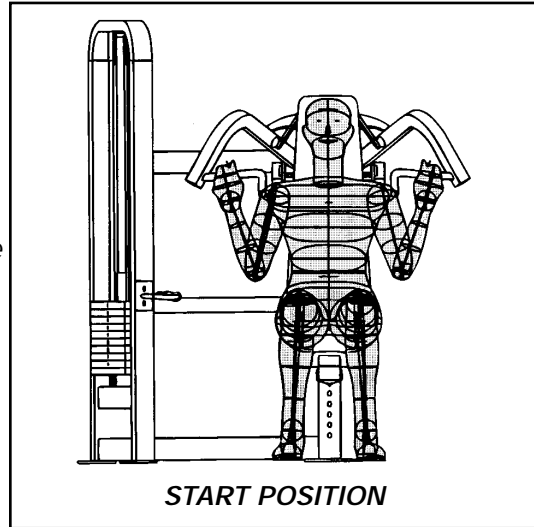

The Advanced Press

- From the wide start position press upward, simultaneously moving the handles toward each other, ending with the arms straight and handles close together.
- Slowly return to the wide starting position without resting.

The Stabilization Press

- Before pressing, move the handles inward a few inches and maintain that width while pressing upward and during the return.

NOTE: Each of the above is a valuable exercise within itself and can be used alone or in combinations.

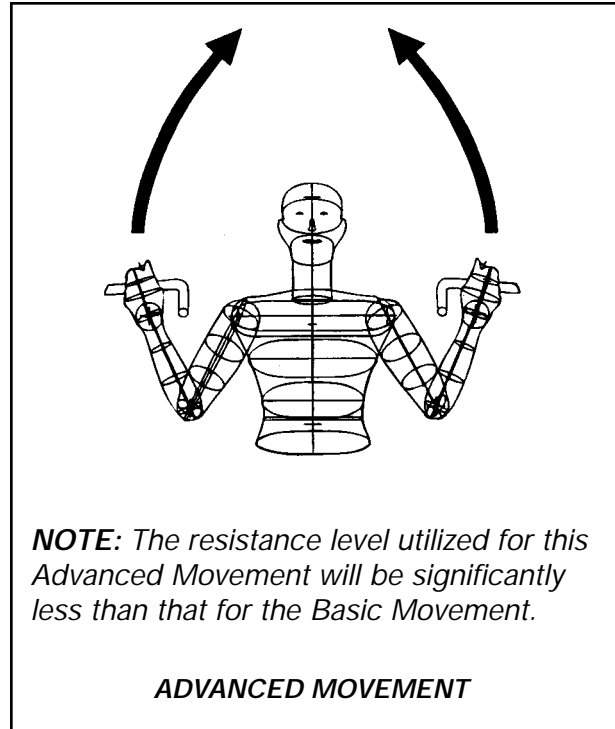

Overhead Press - Single Axis

The Machine

- **Range of Motion Adjustment** - The seat adjustment of the overhead press serves to determine start position and as a range of motion limit.
- **Plane of Motion** - The handles are angled to allow optimum average wrist position throughout the movement. The "barbell" or horizontal position encourages motion in the frontal plane (abduction). The neutral or parallel handles encourage motion in the sagittal plane (flexion). Motion in the sagittal plane (pressing in the front) is considered more functional and safer for the overhead press and is just as (if not more) effective for stimulation of the desired muscles.
- **Variable Resistance** - A cam provides appropriately varying resistance that is maximal at the end of the motion where the body's mechanical advantage increases.
- **10 to 205 Pounds by Fives** - The top plate provides a minimum weight of ten pounds. Subsequent plates in the weight stack are twenty pounds each. Three "slide-on" five pound incremental plates are securely positioned for easy access and effortless addition thereby providing 10 to 205 pounds in five pound increments.

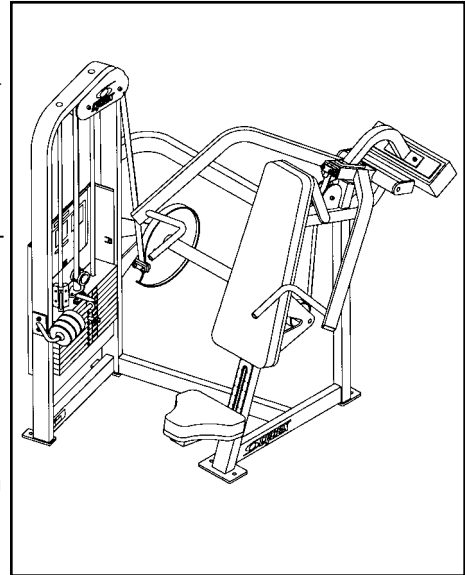

The Shoulders

- **Flexion/Abduction in External Rotation** - The anterior deltoid is primarily responsible for flexion of the shoulder joint as well as abduction of the shoulder joint when combined with 90 degrees of external rotation (overhead press position). The middle deltoid is a prime mover for shoulder abduction, however, it's level of involvement diminishes as the shoulder is externally rotated and the middle fibers are moved posteriorly. The actual degree of middle deltoid involvement varies with the user's individual deltoid structure. The combined positions of external rotation to 90 degrees and abduction to 90 degrees create the most compromising position for the shoulder joint.

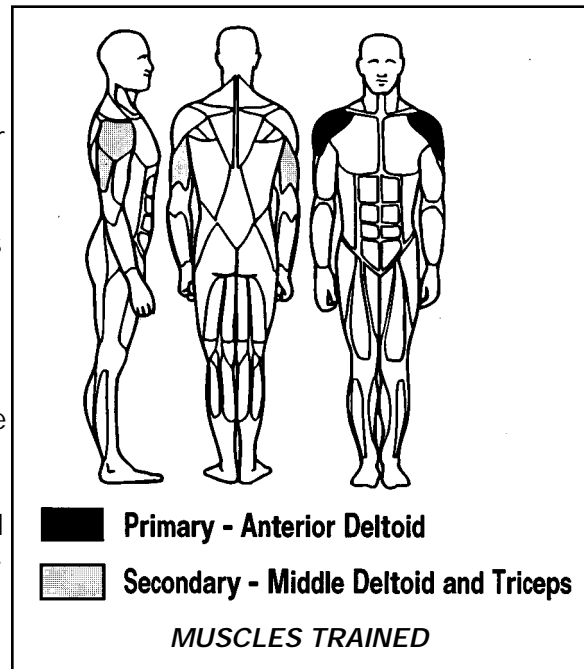

CYBEX VR2 Owner's Manual

- **Range of Motion** - Full normal abduction or flexion begins with the arm at the side in 0 degrees and ends in a vertical position overhead at 180 degrees.
- **Associated Muscles** - Collectively, the scapular muscles are involved in the scapular rotation that is key to scapulohumeral rhythm. This combined motion of the scapula and the shoulder joint is required to achieve elevation of the arm overhead in any plane. The rotator cuff muscles act as dynamic stabilizers during elevation of the arm. The triceps are always involved in pressing movements as elbow extension is required. Due to the externally rotated position, the posterior deltoid plays a stabilizing role at best and in many shoulder structures would prove to be an antagonist to overhead movements.

The Positioning

- Adjust the seat to align the handles with the top of the shoulders.
- Check the weight to insure that the appropriate resistance has been selected. Body position and control of the motion should never be compromised by excessive weight.
- Grip either set of handles and position the elbows directly below the hands.

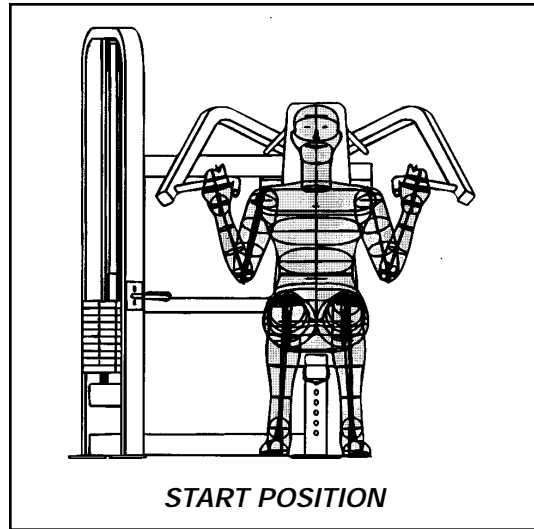

The Motion

- Press the handles upward with a smooth controlled motion.
- Return slowly without resting, keeping the elbows directly below the hands at the bottom of each repetition.

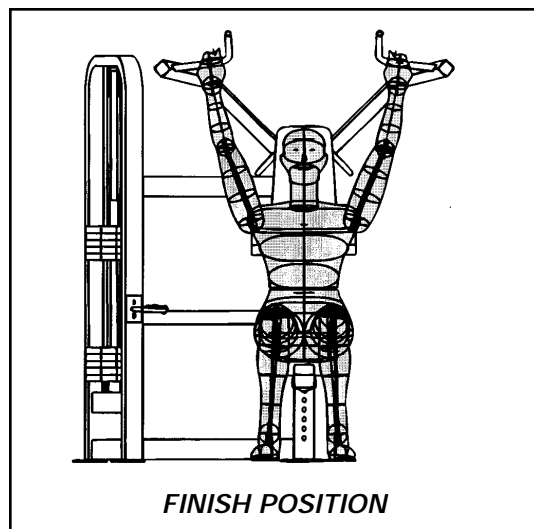

Lat Pull

The Machine

- **Planes of Motion** - The "straight bar"/outer handles allow full motion in the frontal plane (adduction). The parallel/narrow handles are specifically designed to allow motion in the sagittal plane (extension). Motion in the sagittal plane (narrow grip pulldown) is considered more functional and safer for the shoulder. The individual handles allow the user to pull through the center of the body or through the front. The detrimental and minimally effective "behind the neck" position should be avoided by leaning back slightly. The handles are also angled to provide the optimum average wrist position throughout the movement.
- **Variable Resistance** - The machine provides maximum resistance at the beginning of motion and appropriately decreases the resistance to allow full contraction at the end.
- **10 to 305 Pounds by Fives** - The top plate provides a minimum weight of ten pounds. Subsequent plates in the weight stack are twenty pounds each. Three "slide-on" five pound incremental plates are securely positioned for easy access and effortless addition thereby providing 10 to 305 pounds in five pound increments.

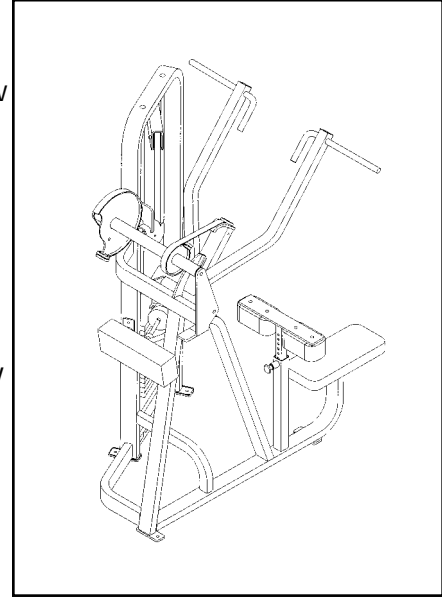

The Latissimus Dorsi

- **Extension/Adduction** - The latissimus dorsi is responsible for extension as well as adduction of the shoulder joint. The lat is also involved in internal rotation of the shoulder, however, this is a mechanically weak motion and becomes the limiting factor in strength when combined with other motions. The teres major works alongside the upper fibers of the lat in adduction and extension. The combined positions of external rotation to 90 degrees and abduction to 90 degrees create the most compromising position for the shoulder joint.
- **Range of Motion** - Full normal adduction or extension begins with the arm in a vertical position overhead at 180 degrees and ends with the arm at the side in 0 degrees. Full concentric shortening of the lat can only occur

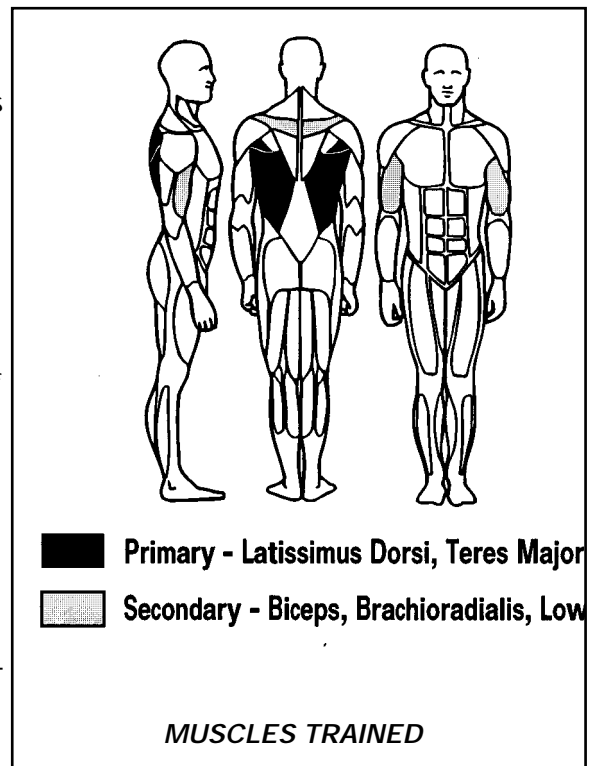

CYBEX VR2 Owner's Manual

when the associated scapular motion is performed with shoulder motion. With motion and resistance from overhead, scapular depression is required. For the arm to return to the starting position overhead the eccentric action of the lat must be accompanied by the scapular rotation of scapulohumeral rhythm.

- **Associated Muscles** - The lower fibers of the trapezius are responsible for scapular depression. Slight retraction is always associated with scapular depression as the lower fibers of the trapezius angle downward and toward midline, attaching on the spine. The long head of the triceps is involved in shoulder extension and adduction, although change in its length is limited when elbow flexion coincides with shoulder motion. The biceps, brachioradialis, and brachialis are always involved in pulling movements as elbow flexion is required. The degree of their individual involvement depends upon radioulnar joint position.

The Positioning

- Adjust the thigh pad to allow access and stabilize the body.
- Check the weight to insure that the appropriate resistance has been selected. Body position and control of the motion should never be compromised by excessive weight.

The Motion

- Grip the narrow/parallel handles.
- Lean back slightly at the hips and maintain.
- Depress the scapula (pinch the shoulder blades down and back).
- While maintaining the scapular position, bring the handles down in front of the face an elbows beside the body.
- Slowly return to the starting position overhead by allowing the scapula to move as needed, but without resting.
- Reset the scapula at the beginning of each repetition.

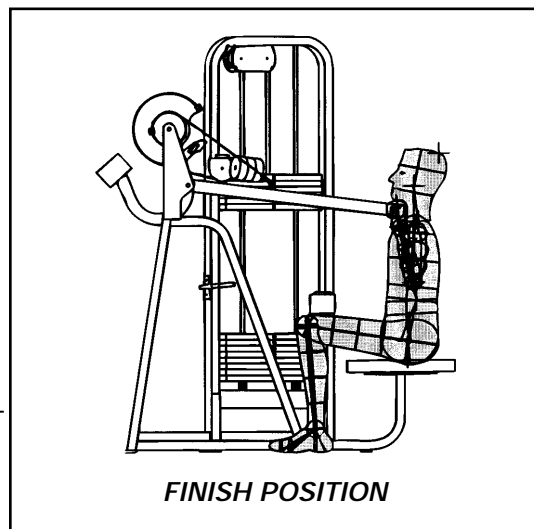
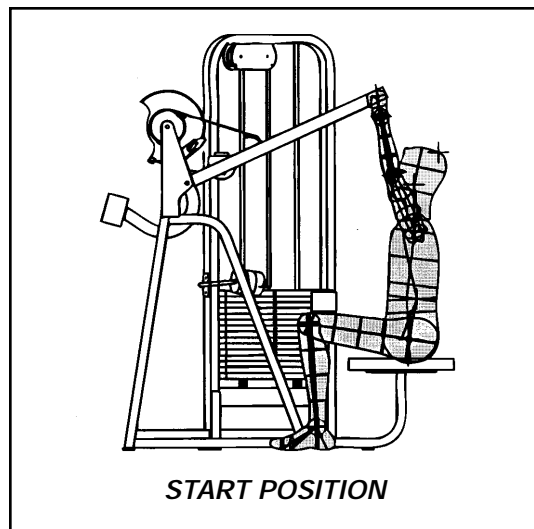

Fly

The Machine

- **Range of Motion Adjustment** - The VR2 Fly eliminates the most hazardous characteristic of traditional fly machines, the danger of excessive stretch. It accomplishes this by providing an adjustable starting position that, when pre-set to the individual user's structure/mechanics, also serves as a range of motion limit.
- **"Virtual Pivot" Axis** - The lever arms (handles/arm pads) are placed on a second axis. This allows the lever arms to "float" toward or away from the user as the fly motion is performed. This solves three problems inherent to traditional fly machines. 1) It eliminates the tendency of the pads to "roll" or "scoot" on the arms because 2) it eliminates the need to perfectly align the primary pivots with the user's shoulder width (a design and manufacturing challenge that is virtually impossible due to the variety of user sizes), and 3) it eliminates the discomfort and limitations associated with the spectrum of user arm lengths and chest thicknesses.
- **Variable Resistance** - The cam provides appropriately varying resistance that matches the strength curve of the associated muscles performing this motion in the defined position.
- **10 to 205 Pounds by Fives** - The top plate provides a minimum weight of pounds. Subsequent plates in the weight stack are twenty pounds each. Three "slide-on" five pound incremental plates are securely positioned for easy access and effortless addition thereby providing 10 to 205 pounds in five pound increments.

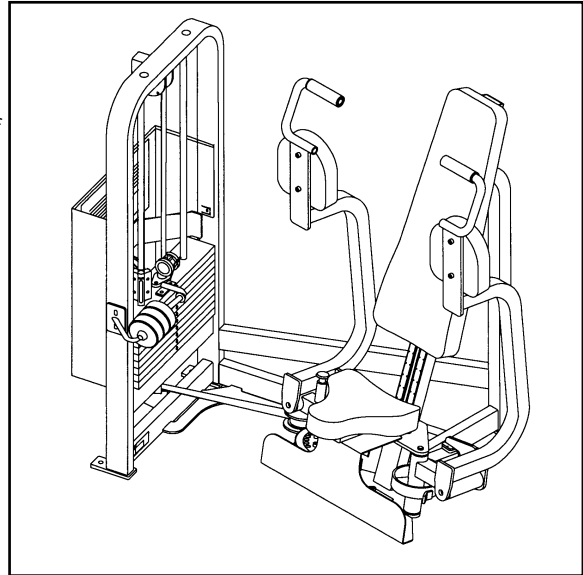

The Chest

- **Horizontal Adduction While Externally Rotated** - The pectoralis major is primarily responsible for horizontal adduction of the shoulder joint. The pec is also involved in flexion and extension of the shoulder joint, although the anterior deltoid and latissimus dorsi muscles, respectively, are mechanically more effective at performing these motions respectively. The pec is also involved in internal rotation of the shoulder, however, this is a mechanically weak motion and becomes the limiting factor in strength when combined with other shoulder motions. Maintaining the shoulder in an externally rotated position during the performance of horizontal adduction allows strengthening of the muscle from a slightly lengthened state when compared to a neutrally rotated (chest press) position. It should also be noted that this position will result in less tension development within the muscle due to the length-tension ratio as well as limiting the final amount of concentric shortening.

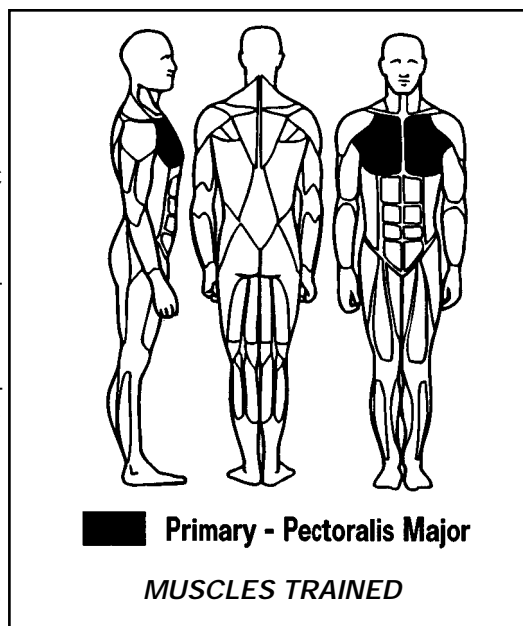

- **Scapular Retraction** - The position of full scapular retraction, when maintained, creates the greatest possible force angles of the pectoralis major throughout the range of motion.
- **Range of Motion** - With scapular retraction maintained, horizontal adduction is limited to approximately 90 degrees (humerus straight to the foot). While maintaining 90 degrees of external rotation, horizontal abduction (achieved through the eccentric "lowering of the weight" or return to the starting position) is limited by mechanical disadvantage at approximately 0 degrees (upper arm straight out from the shoulder) and, much more importantly, by achieving the closed packed position for the shoulder at this point. Here the ligaments reach their maximum length and if horizontally abducted further, while maintaining external rotation, will under go undue stress.
- **Associated Muscles** - The anterior deltoid and caracobrachialis are also prime movers for the motion of horizontal adduction. However, by maintaining motion in the horizontal plane, scapular retraction, and limited horizontal abduction (limited stretch) the pectoralis major will be emphasized over the anterior deltoid. Mechanical analysis indicates that the effectiveness of the anterior deltoid in horizontal adduction may be slightly reduced in the externally rotated position.

The Positioning

- Adjust the seat height so that elbows are slightly below shoulders when grasping handles.
- Adjust handle position, by releasing the pushbutton located below the seat to the right, so that the upper arm is straight to side when handle is grasped.
- Check the weight to insure that the appropriate resistance has been selected. Body position and control of the motion should never be compromised by excessive weight.
- Grip the handles and position the forearms on the pads by moving the lever arms inward to a comfortable width.
- Retract the scapulae. Monitor and maintain this position on all movements for the chest.

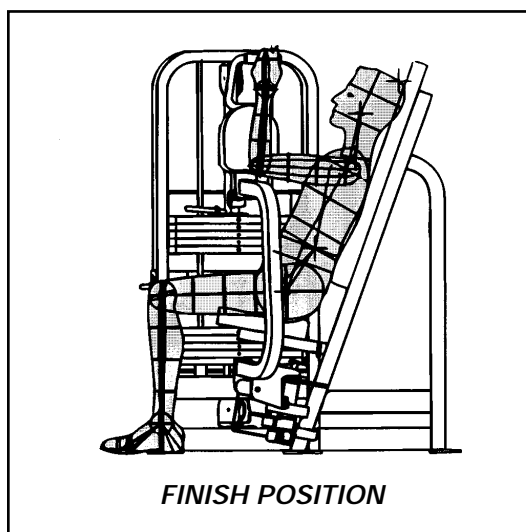
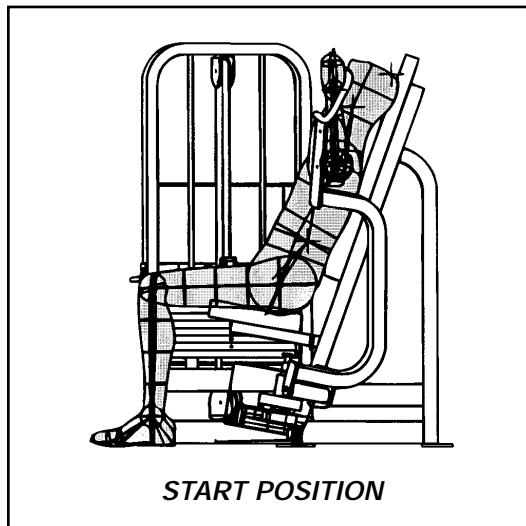

The Motion

- Tighten the chest and slowly bring the handles together in front without changing the position of the scapulae.
- Maintaining a slow smooth motion, return to near the starting position without relaxing the muscles.

CYBEX VR2 Owner's Manual

(This page intentionally left blank)

Lateral Raise

The Machine

- **Placement of Resistance** - The Lateral Raise decreases the dangers of excessive shoulder joint shear by placing the resistance at the elbow. The elimination of the chest pad allows for more precise alignment of the resistance with the fiber direction of the lateral deltoid.
- **Plane of Motion** - The long input arms combined with a swivel handle allow for smooth shoulder abduction and maximum pad contact.
- **Variable Resistance** - A cam provides appropriately varying resistance that decreases at the end of the range of motion, where that lateral deltoid has less mechanical advantage.
- **10 TO 205 POUNDS BY FIVES** - The top plate provides the minimum weight of ten pounds. Subsequent plates in the stack are twenty pounds each. Three "slide-on" five pound increment plates are securely positioned for Easy access and effortless addition thereby providing 10 to 205 pounds in Five pound increments.

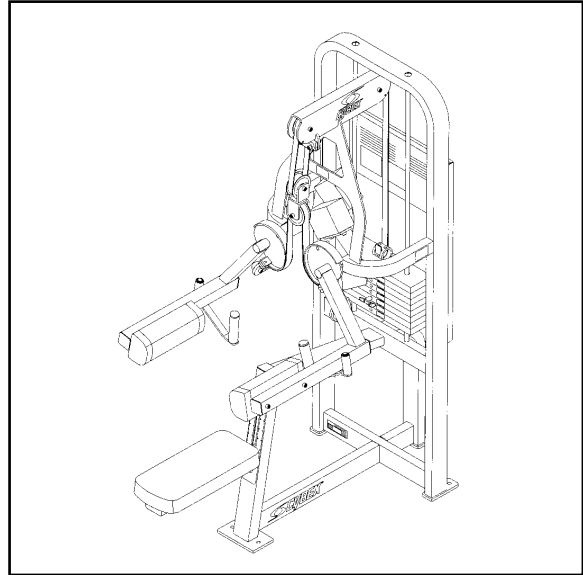

The Shoulders

- **Abduction** - The lateral deltoid is responsible for abduction of the shoulder joint.
- **Scapular Retraction** - The position of slight scapular retraction, when maintained, creates improved force angles for the deltoid throughout the range of motion. The movement may also be performed for more functional training, by allowing the scapular motion.
- **Range of Motion** - When the upper arm is in neutral rotation, the range of abduction is 90° at the shoulder joint. Further range of motion is prevented by the contact of bone processes in the shoulder.

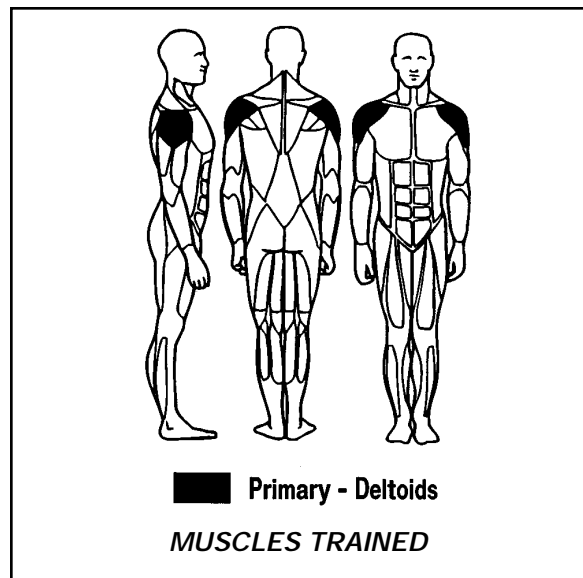

The Positioning

- Adjust the seat height to allow the shoulders to align with the axis of rotation of the cams.
- Check the weight to insure that the appropriate resistance had been selected. Body position and control should never be compromised by excessive weight.
- Maintaining proper spinal position, lean forward slightly at the waist to align the lateral deltoid (which typically lies slightly posterior of center) with the path of motion of the machine.

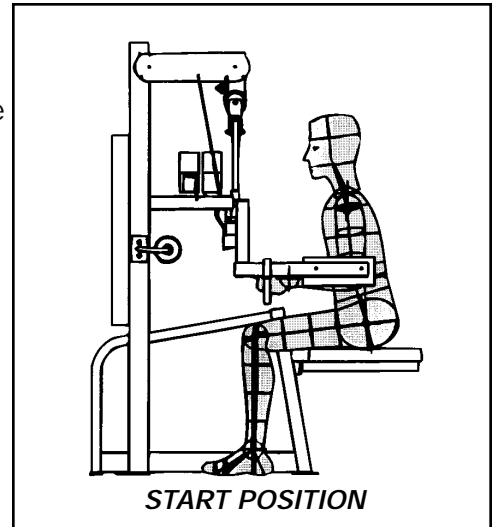

The Motion

- Grip the handles lightly and allow your upper arm to maintain a vertical position, perpendicular with the machine arms.
- Choose either to maintain slight scapular retraction or allow functional motion, raise elbows to a level at or near shoulder height using smooth controlled movements.
- Return to the starting position and repeat the motion without resting.
- If unable to maintain the shoulder position for your goal, decrease the weight and repeat exercise

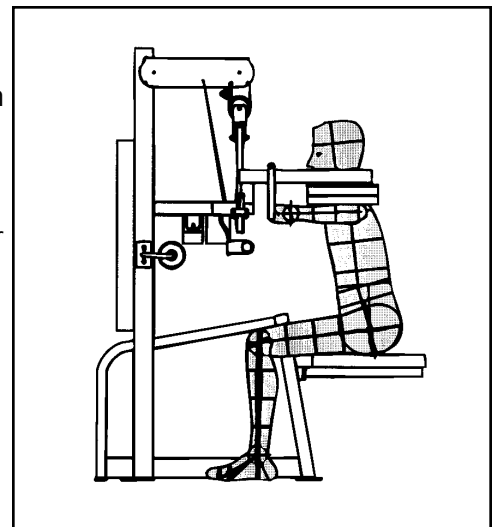

Lateral Raise

The Machine

- **Axis Alignment** - The axis or pivot point of the machine is properly positioned to allow alignment with the elbow joints.
- **Accommodating Grip** - The rotating handles accommodate to the user's ability to achieve supination. A neutral position can be employed to emphasize the brachioradialis, however, the handles, designed specifically for the biceps, are angled slightly for proper wrist/grip alignment in full supination.
- **Variable Resistance** - The cam provides increased resistance at the point in the range where force output of the biceps is the greatest.
- **10 to 205 Pounds by Fives** - The top plate provides a minimum weight of ten pounds. Subsequent plates in the weight stack are twenty pounds each. Three "slide-on" five pound incremental plates are securely positioned for easy access and effortless addition thereby providing 10 to 205 pounds in five pound increments.

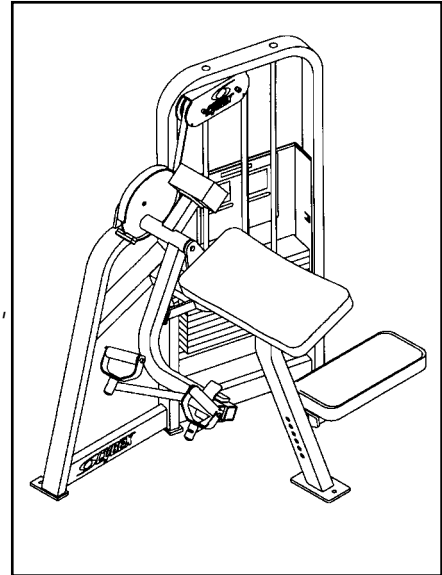

The Biceps

- **Elbow Flexion** - The triceps brachii is responsible for extension of the elbow joint as well as supination of the radioulnar joint. The biceps are most effective at performing elbow flexion when the position of full supination is maintained throughout the entire range of motion. The biceps also cross the shoulder joint, although it is more effective at stabilizing the shoulder than moving it. It should be noted that any movement of the shoulder joint during resisted elbow flexion usually decreases the effectiveness of the exercise by allowing unresisted change in the biceps' length.
- **Range of Motion** - Normal elbow motion is 0 to 150 degrees. During isolated biceps work the range of motion is limited by the user's ability to control the biceps in flexion concentrically and extension eccentrically.

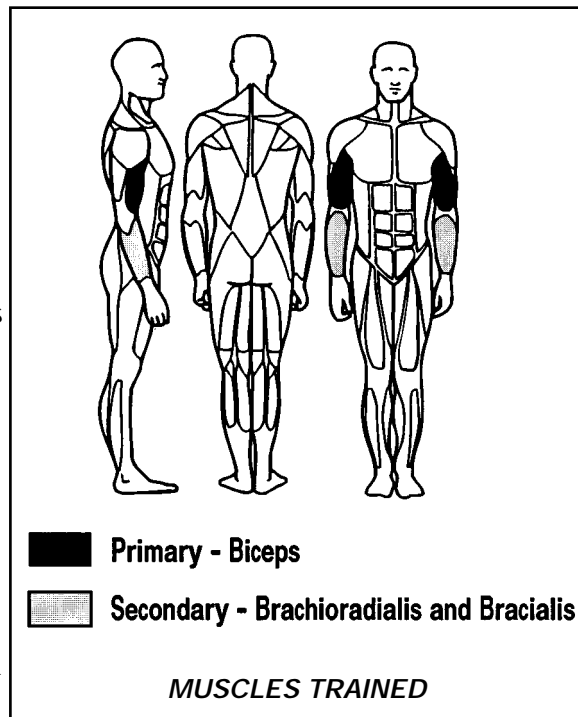

CYBEX VR2 Owner's Manual

- **Associated Muscles** - The brachialis and brachioradialis are both prime movers for elbow flexion. The brachialis is equally effective in all radioulnar positions, however, it is emphasized alone when pronation is maintained during elbow flexion due to the decreased effectiveness of the biceps and brachioradialis in this position. The brachioradialis is emphasized when the neutral (hammer) position is maintained.

The Positioning

- Adjust the seat to allow the upper arm to rest on the pad.
- Check the weight to insure that the appropriate resistance has been selected. Body position and control of the motion should never be compromised by excessive weight.
- Grip the handles and rotate to the desired position.
- Sit with the spine erect and scapula retracted.
- Position the arms parallel to each other.
- Note the pivot point at the right edge of the arm pad. Position the elbows in line with the pivot point.
- By depressing the scapula (lowering the shoulders), press the upper arms firmly into the pad and elevate the elbows slightly.

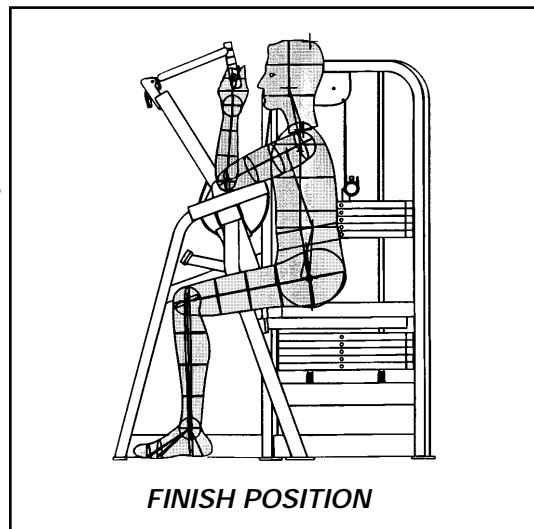
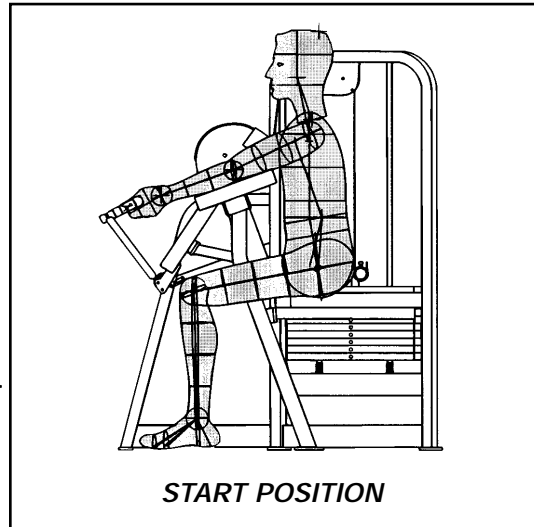

The Motion

- Tighten the biceps and flex the elbows as far as possible without raising the elbows further.
- Return to the starting position without resting and without changing the shoulder arm position or elbow alignment.

Arm Extension

The Machine

- **Axis Alignment** - The axis or pivot point of the machine is properly positioned to allow alignment with the elbow joints.
- **Neutral Grip** - The neutral handles allow full extension without shoulder rotation as well as a powerful and stable position of the wrist and hand.
- **Variable Resistance** - The cam provides increased resistance at the point in the range where force output of the triceps is the greatest.
- **10 to 205 Pounds by Fives** - The top plate provides a minimum weight of pounds. Subsequent plates in the weight stack are twenty pounds each. Three "slide-on" five pound incremental plates are securely positioned for easy access and effort less addition thereby providing 10 to 205 pounds in five pound increments.

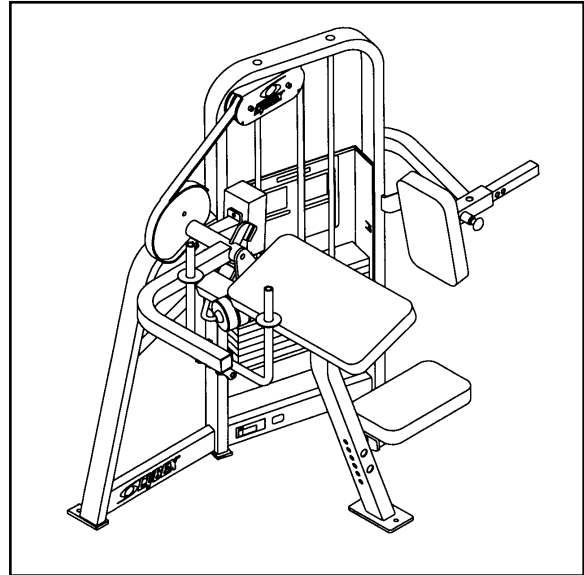

The Triceps

- **Elbow Extension** - The triceps brachii is responsible for extension of the elbow joint. The triceps insert on the olecranon of the ulna and is not involved in or directly affected by the position of the radioulnar joint. However, full pronation often encourages internal rotation of the shoulder in order to achieve full elbow extension. The long head of the triceps originates on the scapula and is an assistant mover of shoulder extension and adduction, however, it is more effective at stabilizing the shoulder than moving it. It should be noted that any movement of the shoulder joint during resisted elbow extension may decrease the effectiveness of the exercise.
- **Range of Motion** - Normal elbow motion is 0 to 150 degrees. During isolated triceps work the range of motion is limited by the user's ability to control the triceps in extension concentrically and flexion eccentrically.
- **Associated Muscles** - The anconeus is also a prime mover for elbow extension.

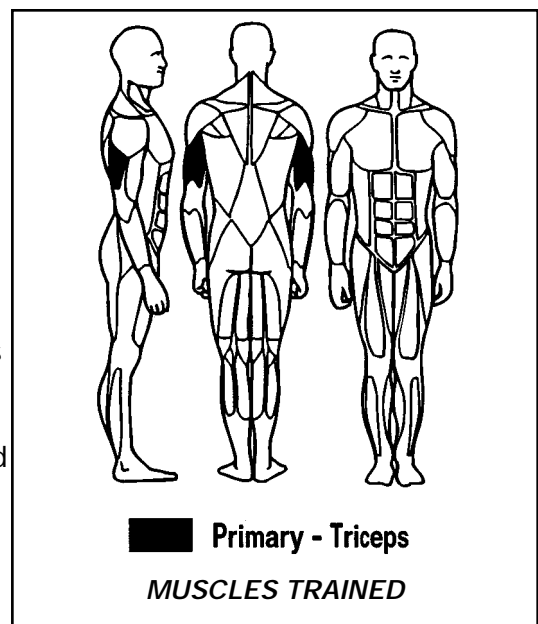

The Positioning

- Adjust the seat to allow the upper arm to rest on the pad.
- Note the pivot point at the right edge of the arm pad. Position the elbows in line with the pivot point.
- Adjust the back pad to provide support in maintaining the elbow/axis alignment.
- Check the weight to insure that the appropriate resistance has been selected. Body position and control of the motion should never be compromised by excessive weight.
- Swing the handles back and grip.
- Position the arms parallel to each other.
- Sit with the spine erect and scapula retracted.

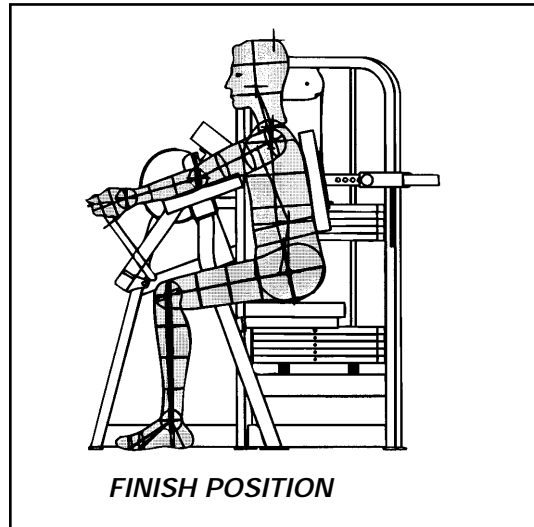
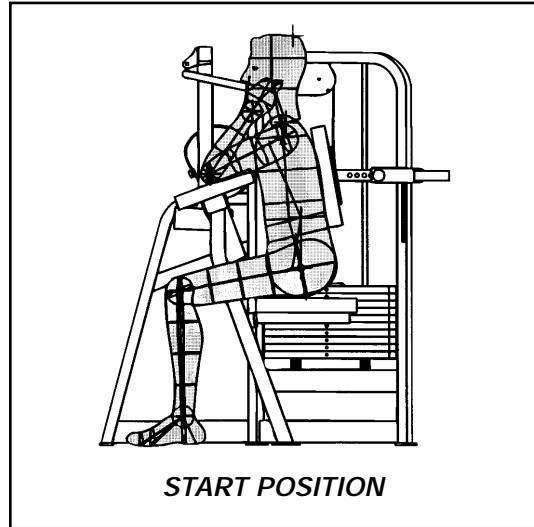

The Motion

- Tighten the triceps and extend the elbows as far as possible without raising the elbows or shoulders.
- Return to the starting position without resting and without changing the shoulder/arm position or elbow alignment.

Ab Crunch

The Machine

- **Arc Alignment** - The axis or pivot point of the machine is positioned posterior to the spine. This creates a downward arc of motion matching spinal flexion and eliminating hip flexion and hip flexor activity.
- **Range of Motion** - The seat height adjustment allows for varying torso lengths and serves as a range of motion limit. Fine tuning of the range of motion can be made by moving forward or backward slightly on the seat.
- **Resistance Application** - The resistance is applied through an arm pad which is designed to further prevent hip flexor use.
- **Stabilization** - A foot plate/strap is not available to encourage use of the hip flexors. A seat belt is provided to secure the body when the amount of resistance employed nears the weight of the body. This belt is positioned near the hip joints to decrease use and leverage of the hip flexors.
- **10 to 205 Pounds by Fives** - The top plate provides a minimum weight of ten pounds. Subsequent plates in the weight stack are twenty pounds each. Three "slide-on" five pound incremental plates are securely positioned for easy access and effortless addition thereby providing 10 to 205 pounds in five pound increments.

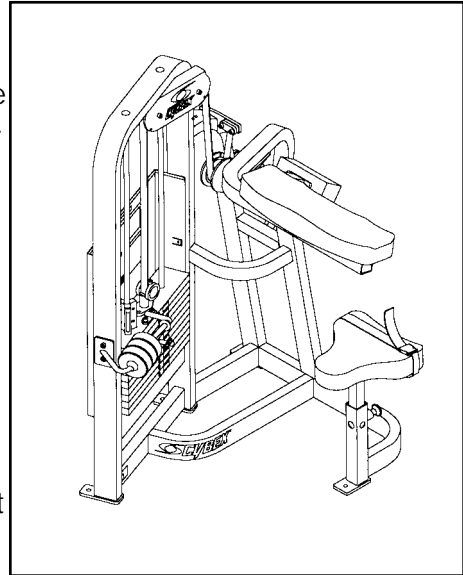

The Abdominals

- **Spinal Flexion** - The rectus abdominis is responsible for flexion and stabilization of the spine. The internal and external obliques work bilaterally as synergists in their roles as prime movers for spinal flexion.
- **Range of Motion** - Unless a restriction occurs or is prescribed, range of motion is limited only by the user's ability to control the abdominals concentrically into full flexion and eccentrically into hyperextension.
- **Associated Muscles** - The transverse abdominis is not situated to assist with spinal flexion. Attempts at involving this muscle in the crunch by "sucking in" will decrease the effectiveness of the rectus abdominis.

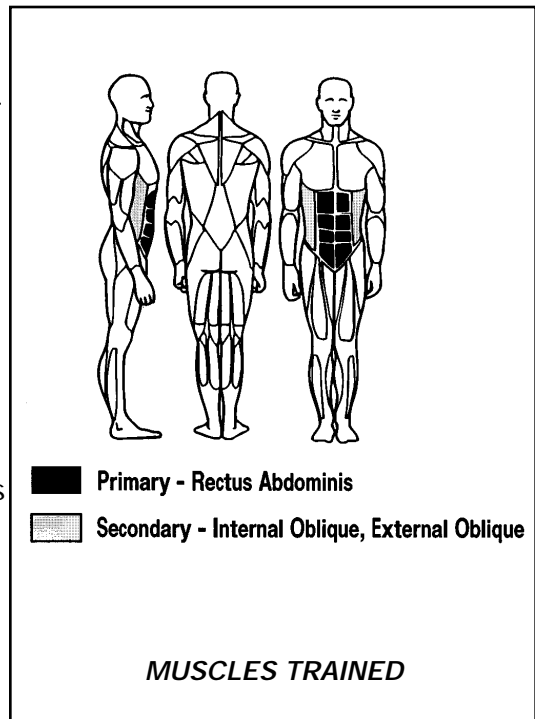

The Positioning

- Adjust the seat to align the arm pad with the top of the shoulders/base of the neck. Raise the seat to decrease range of motion. Lower the seat to increase range of motion.
- Check the weight to insure that the appropriate resistance has been selected. Body position and control of the motion should never be compromised by excessive weight.
- Position the feet flat on the floor and use the seat belt if needed.
- Cross the arms over the pad and sit erect with the chest near the edge of the pad.

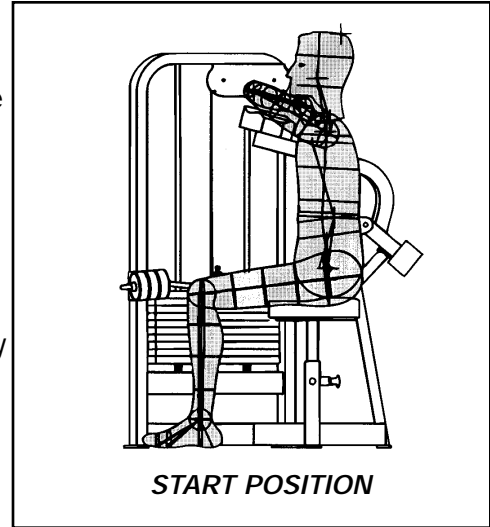

The Motion

- Tighten the abdominals and crunch smoothly as far as possible. Stabilize the shoulders and lead with the ribs.
- Slowly return to the starting position without resting.

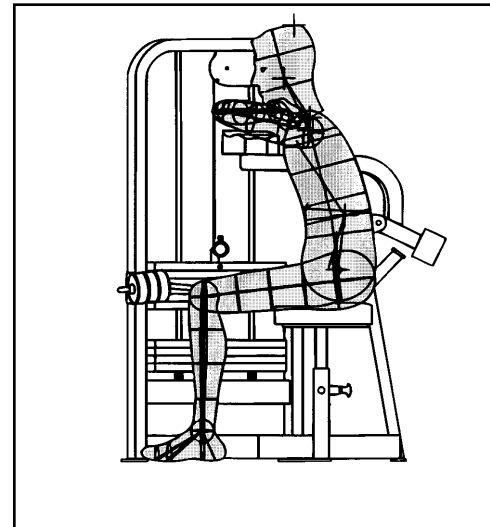

Back Extension

The Machine

- **Three Models** - The 4711 model provides standard (non-RLD) operation. The 4712 model contains an adjustable start position so that the ultimate degree of knee flexion at the start of the movement can be determined. The 4713 model provides both an adjustable start and an adjustable end position for total control of the user's range of motion.
- **Range of Motion Limitation** - The range limiting device allows quick, easy adjustment of the start (4712, 4713) and end positions (4713) for those user's with limited hamstring flexibility or for rehab purposes. The RLD maintains the correct biomechanical relationship between the lever arm and the cam which is critical in maintaining the proper resistance variation through the chosen range.
- **Axis Alignment** - The axis or pivot point of the machine is positioned to be aligned with the hip joints.
- **Stabilization** - The footplate is adjustable to stabilize the hip in axial alignment. A seat belt is provided to secure the body.
- **10 to 305 Pounds by Fives** - The top plate provides a minimum weight of ten pounds. Subsequent plates in the weight stack are twenty pounds each. Three "slide-on" five pound incremental plates are securely positioned for easy access and effortless addition thereby providing 10 to 305 pounds in five pound increments.

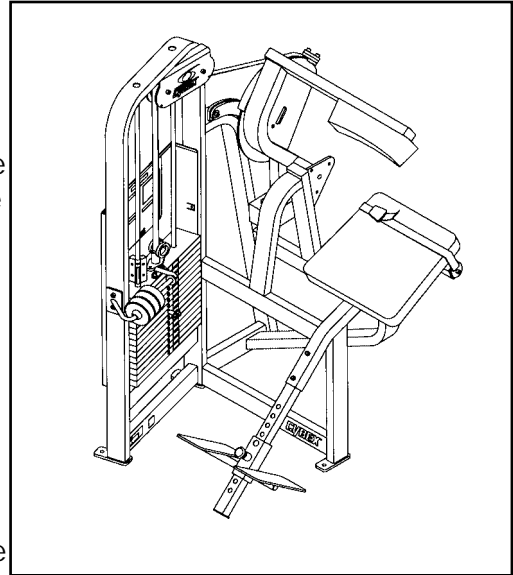

The Erector Spinae

- **Spinal Extension** - The erector spinae are responsible for extension and stabilization of the spine.
- **Range of Motion** - Motion of the spine is eliminated in this exercise. The goal is to maintain proper spinal alignment with the erector spinae during resisted hip extension. This is identical to the proper functional lifting motor pattern required in daily activity. Hip motion should be limited to that which can be performed with proper spinal alignment.
- **Associated Muscles** - The gluteus maximus and hamstrings are responsible for hip extension. The hamstrings will be involved to a lesser degree due to the position of slight knee flexion.

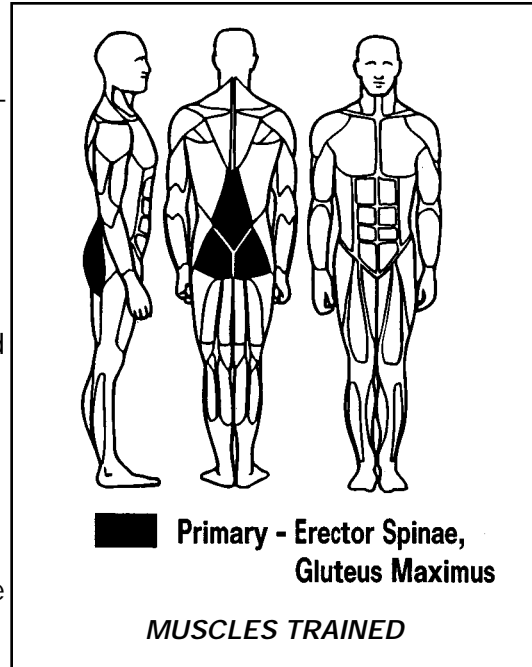

The Positioning

- While seated with the weight stack selector pin removed, position both feet on the footplates and your back against the pad.
- Extend the legs until the posterior thigh is against the seat.
- Check hip joint alignment with the pivot point.
- Move the foot plate to properly align the hip, maintaining contact of the thigh against the seat.
- Stabilize this position with the seat belt.
- Select the appropriate resistance. Body position and control of the motion should never be compromised by excessive weight.

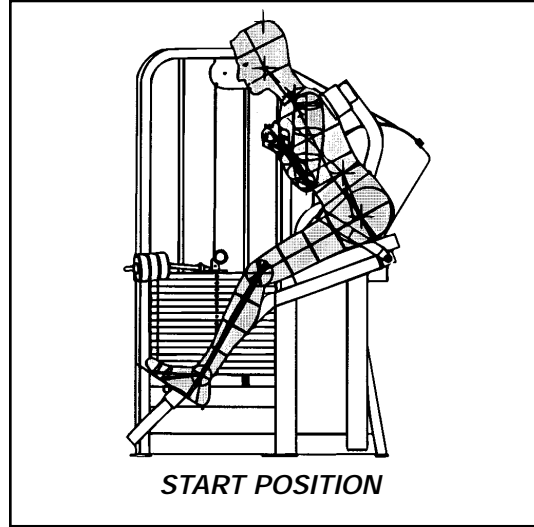

The Movement

- Cross your arms and straighten the spine by "lifting the chest".
- Press against the back pad and slowly extend as far as possible, maintaining proper spinal alignment.
- Control the return forward without resting and keeping the "chest up" to insure proper spinal alignment.

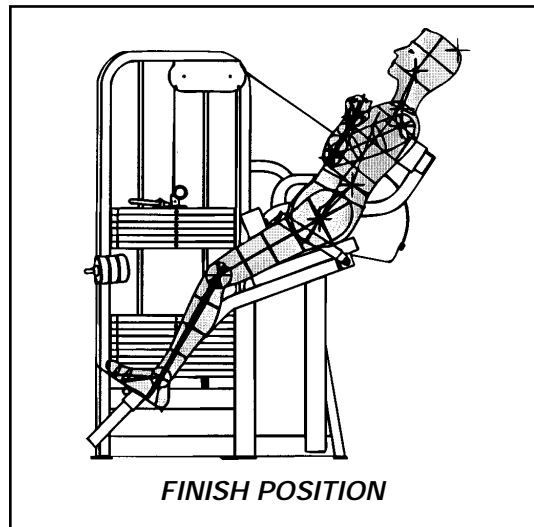

The Positioning

- **Set Start Position**

1. Grasp pull pin (pullbutton) and pull.
2. Move input arm to desired position.
3. Lock pull pin into place.

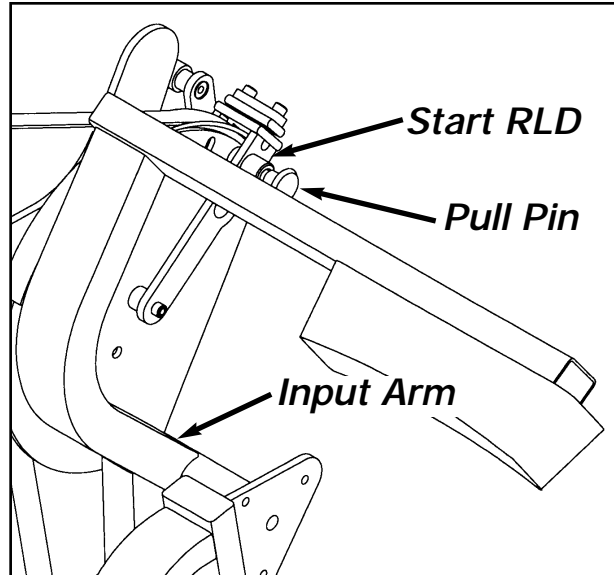

- **Set Stop (End) Position**

1. Grasp pull pin (pullbutton) and pull.
2. Rotate stop to the desired starting position.
3. Lock pull pin into place.

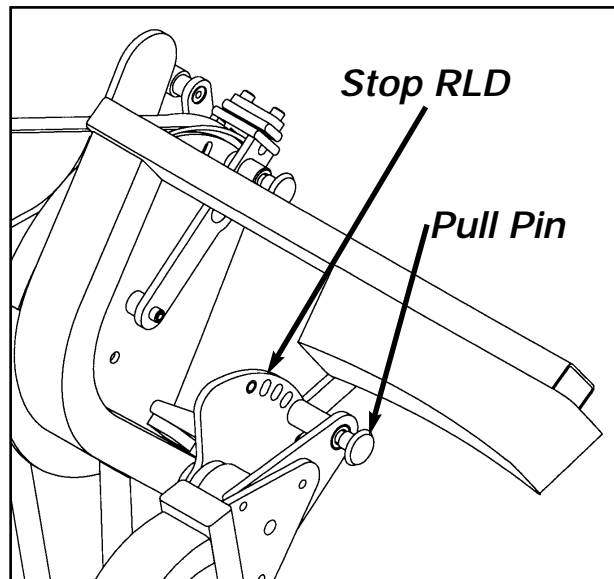

Torso Rotation

The Machine

- **Stabilization** - The upper torso is stabilized against an anterior chest pad. This utilizes the upper extremity to assist with stabilization, rather than movement of the resistance. Additionally, as motion of the upper body/torso is eliminated, the head may remain in a fixed and focused position. This aids to improve performance and decrease the opportunity for vestibular stimulation and the potential for dizziness.
- **Range of Motion Adjustment** - A push button mechanism between the leg pads allows the user to easily preset the degree of rotation for the start/end position at 30, 45, 60 or 75 degrees while in the seated position. The end of the concentric movement, although ultimately subject to the control/ability of the user, is limited at a maximal range of 75 degrees.
- **Resistance Application** - The resistance is applied securely through the lower body. This dramatically reduces inefficient movement of the resistance by poorly stabilized extremities (a common problem with traditional rotary torso machines that utilize the upper extremity to maintain contact with the resistance). The drive mechanism eliminates the "slack" found in most machines that offer multi-directional concentric movement, thereby allowing *immediate* resistance.
- **10 to 205 Pounds by Fives** - The top plate provides a minimum weight of ten pounds. Subsequent plates in the weight stack are twenty pounds each. Three "slide-on" five pound incremental plates are securely positioned for easy access and effortless addition thereby providing 10 to 205 pounds in five pound increments.

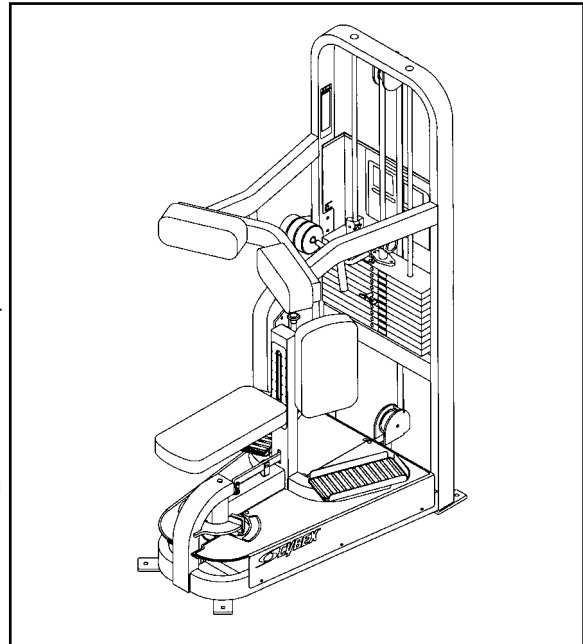

The Rotators

- Reverse Action Spinal Rotation** - Spinal rotation is defined by the movement of the upper torso upon a stabilized pelvis. The Torso Rotation machine works in biomechanical reverse action defined by the lower torso/pelvis moving beneath the stabilized upper torso. Although the same muscles will be working in their respective roles as prime movers, the orientation is different. Therefore, the internal obliques and erector spinae which are responsible for spinal rotation to the same side respectively, perform pelvic rotation to the opposite side. The external obliques and rotators/multifidus are responsible for spinal rotation to the opposite side respectively, or pelvic rotation to the same side. Another way to view the muscular action is relative to the motion itself. Pelvic rotation to the right is performed by the left internal oblique, left erector spinae, right external oblique, and right rotator/multifidus group. Pelvic rotation to the left is performed by the right internal oblique, right erector spinae, left external oblique, and left rotar/multifidus group.

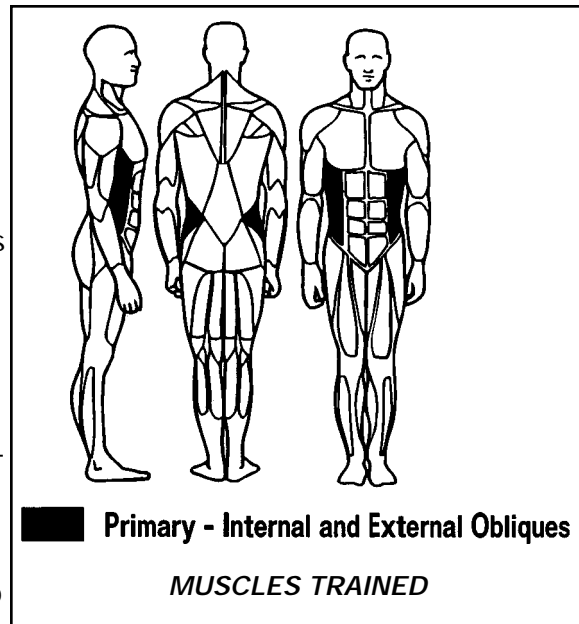

- Range of Motion** - Measurement of spinal motion is subject to considerable variation. Unless a restriction occurs or is prescribed, strict thoraco-lumbar rotation is generally considered to be 30 to 40 degrees to each side. However, range of motion for resistance exercise should be limited to the user's ability to control the muscular contraction concentrically and eccentrically.
- Important** - It is often suggested that rotation of the spine creates one of the most traumatic forces on the intervertebral disk, torsion. In their textbook *Joint Structure and Function*, Norkin and Levangie state, "It has been suggested that the annulus fibrosis [of the intervertebral disk] may be the most effective structure in the lumbar region for resisting torsion. However, the risk of rupture of the disk fibers is increased when torsion, heavy axial compression, and bending are combined." Preventing unnecessary rotation in daily life is advised, however; strong spinal muscles provide support for the spine and its components. Increased strength and control of these muscles may be one of the best ways to prevent spinal problems and eliminate some of the risk associated with situations that *demand* spinal rotation such as sports and work related activities. To make this exercise as safe and effective as possible *always* maintain proper spinal alignment as well as slow controlled motions.

The Positioning

- Adjust the seat height to align the chest pads across the upper chest.
- Place the feet comfortably on the footplates and position the legs securely against the adductor pads.
- While seated, preset the starting position by pushing the seat angle adjusting knob and rotating the seat either left or right to the desired degree. Insure that the seat is locked in position before beginning the movement.
- Check the weight to insure that the appropriate resistance has been selected. Body position and control of the motion should never be compromised by excessive weight.
- Sitting upright with proper spinal alignment, grasp the handles and pull the chest firmly to the pads.

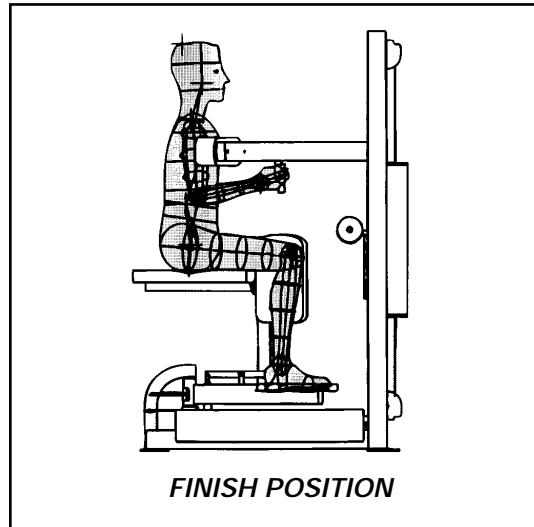
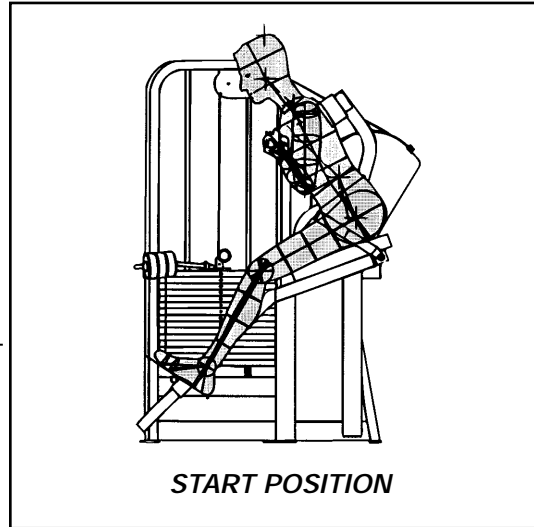

The Motion

- Maintaining contact with the chest pads, tighten the torso muscles and slowly rotate through the desired range of motion.
- With a smooth controlled motion, return to the starting position without resting.
- Push the seat angle adjusting knob and select a starting position for the opposite side. Repeat the exercise.

This page intentionally left blank

Chapter 4 - Customer Service

Contacting Service

Hours of phone service are Monday through Friday from 8:00 a.m. to 6:00 p.m. Eastern Standard Time.

For Cybex customers living in the USA, contact Cybex Customer Service at **800-766-3211**.

For Cybex customers living outside the USA, contact Cybex Customer Service at **508-533-4300** or fax **508-533-5183**.

Order parts and find information on the web at www.cybexinternational.com or by e-mail at techhelp@cybexintl.com.

Ordering Parts

Visit cybexinternational.com to shop for parts online or fax your order to **508-533-5183**. To speak with a customer service representative, call **800-766-3211** (for customers living within the USA) or **508-533-4300** (for customers outside the USA). You may also contact us through email at techhelp@cybexintl.com

Having the following information ready when calling will assist our Cybex representatives in serving you:

- **Unit Serial Number**
- **Product Name**

The unit serial number and product name can be found on the serial number decal. See Chapter 8 for exact location of serial number decal.

- **Part Description**
- **Part Number**

Part descriptions and part numbers are located in Chapter 8 of this manual.

CYBEX VR2 Owner's Manual

- Shipping Address
- Contact Name

In addition to your shipping address and contact name, your account number is helpful but not required.

Return Material Authorization (RMA)

The Return Material Authorization (RMA) system outlines the procedures to follow when returning material for placement, repair, or credit. The system assures that returned materials are properly handled and analyzed. Follow the following procedures carefully.

Contact your authorized Cybex dealer on all warranty-related matters. Your local Cybex dealer will request a RMA from Cybex, if applicable. Under no circumstances will defective parts or equipment be accepted by Cybex without proper RMA and an Automated Return Service (ARS) label.

1. Call the Customer Service Hotline listed above for the return of any time that is defective.
2. Provide the technician with a detailed description of the problem you are having or the defect in the item you wish to return.
3. Provide the model and serial number of your Eagle equipment
4. At Cybex's discretion, the technician may request that you return the problem part(s) to Cybex for evaluation and repair or replacement. The technician will assign you a RMA number and will send you an ARS label. The ARS label and the RMA numbers must be clearly displayed on the outside of the package that contains the item(s) to be returned. Include the description of the problem, the serial number of the Eagle equipment and the name and address of the owner in the package along with the part(s).
5. Forward the package through UPS to Cybex.
Attn: Customer Service Department
Cybex International, inc.,
10 Trotter Drive
Medway, MA 02053

NOTE: Merchandise returned without an RMA number on the outside of the package or shipments sent C.O.D. will not be accepted by the Cybex receiving department.

Damaged Parts

Materials damaged in shipment should not be returned for credit. Shipping damages are the responsibility of the carrier (UPS, Federal Express, trucking companies, etc.)

Apparent Damage - Upon receipt of your shipment, check all items carefully. Any damage seen with a visual check must be noted on the freight bill and signed by the carriers agent. Failure to do so will result in the carriers refusal to honor your damage claim. The carrier will provide you with the required forms for filing such claims.

Concealed Damage - Damage not seen with a visual check upon receipt of a shipment but notices later must be reported to the carrier as soon as possible. Upon discovery of the damage, a written or phone request to the carrier asking them to perform an inspection of the materials must be made within ten days of the delivery date. Keep all shipping containers and packing materials as they will be needed in the inspection process. The carrier will provide you with and inspection report and the necessary forms for filing a concealed damage claim. Concealed damage claim is the carriers responsibility.

CYBEX VR2 Owner's Manual

This page intentionally left blank

Chapter 5 - Delivery & Installation

We would like to take this opportunity to thank you for your purchase of CYBEX Strength Systems and to assure you that our commitment to excellence includes a dedication to customer service.

Freight and inside delivery charges cover trucking and handling costs necessary to place your equipment in any pre-determined location in your facility. This does not include unusual or special circumstances. If you purchased installation, your equipment will be assembled for you.

A thorough inspection of our CYBEX Strength Systems ensures that the equipment leaves our facility in flawless condition. Although unlikely, minor damage may occur in transit from our plant to your facility. Therefore, to guarantee that any damage is covered and then corrected, we ask that you follow the procedure below upon delivery to help ensure your satisfaction.

Delivery Inspection

Upon arrival, it is important that you thoroughly inspect all of the equipment for damage.

If you discover damage, point it out to the truck driver and request that the driver make a record of the damage on the receiving report. Be sure to obtain a copy of the receiving report for your files.

- Contact CYBEX Technical Support if you received damaged equipment and provide them with the information on the report regarding your damaged equipment.
- Contact CYBEX Inside Sales if you did not receive the appropriate equipment and provide them with the information regarding your order.

You may call CYBEX at 1-888-462-9239 (1-888-GO CYBEX) and specify if you are calling for a Technical Support Representative or an Inside Sales Representative.

Installation

Allow the appropriate operating space between machines. It is the responsibility of the purchaser to determine the appropriate operating space for customer safety and convenience. Do not crowd the exercise area.

Cybex VR2 Owner's Manual

Anchoring

Anchoring machines provide maximum stability.

Securely anchor each piece of Strength Systems equipment to the floor using the anchor holes provided with each machine.

NOTE: *CYBEX is not responsible for the actual anchoring of equipment. Consult with a professional contractor.*

Use fasteners having a minimum of 500 lbs. tensile capacity (3/8" grade 2 bolts or better).

If all legs/frames do not contact surface, DO NOT pull down with anchors. Shim any leg or frame not in contact with surface with flat washers.

Safety

Use extra caution when assembling and installing equipment, particularly when lifting or moving heavy objects (such as installing weight stacks) and when using power tools.

Before using any machine, read and understand the following material:

- Warning and caution labels
- Chapter 2 - General Exercise Guidelines
- Chapter 3 - Exercises
- Chapter 6 - Maintenance

TOOLS REQUIRED

- 5/16" Allen wrench
- 9/16" Socket/ratchet
- 3/4" Socket/ratchet
- External snap ring pliers
- Medium weight automotive engine oil

1. Read and understand all instructions thoroughly before starting this procedure.

2. Before installing the weight stack.

- Place machine in desired location.
- Look at the shipping supports.
- For cone-shaped shipping supports, use a 3/4" socket or wrench and carefully remove each cone.
- For plastic foot glides, see the Foot Glide Removal instruction sheet shipped with each machine.
- Place rubber feet (supplied with machine) on each foot of the frame.

2. Installing weight stack.

- Using an external snap ring pliers, slide the lower snap ring (and wave washer) down and about 2 inches from the top part of the guide rod (this will provide access to the upper snap ring). Repeat this step for the other guide rod. See Figures 1 and 2.

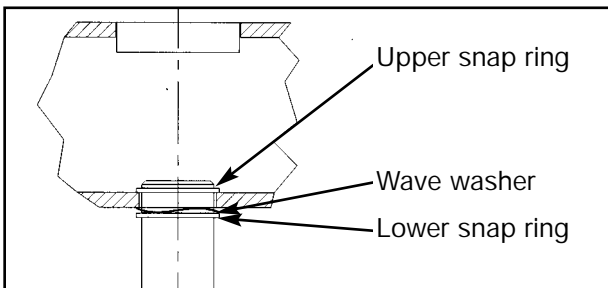

Figure 1

- Remove the plastic cap on guide rod hole by gently lifting guide rod up and down until plastic cap is forced off. Repeat this step for the other guide rod. See Figure 2.

- Raise guide rod high enough to expose the upper snap ring. Using an external snap ring pliers, remove snap ring and lower guide rod. Then remove the lower snap ring and wave washer. Repeat this step for the other guide rod. See Figure 2.

- Lean guide rod toward weight stack guard .
NOTE: For the Hip Abduction, Hip Adduction and Rotary Calf machines, lean guide rod away from the weight stack guard. See Figure 2.

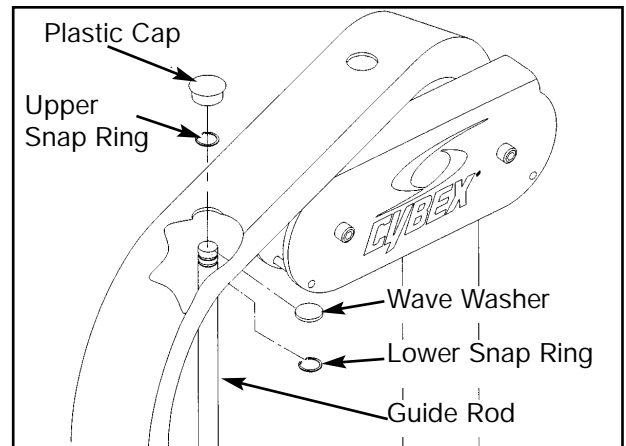

Figure 2

- Remove top weight increment rod from the top weight. See Figure 3.
- While an assistant is holding the top weight, remove shipping tie and foam securing the top weight.
- Slide top weight up and out of machine and carefully set it aside (see note in step 2, letter I).

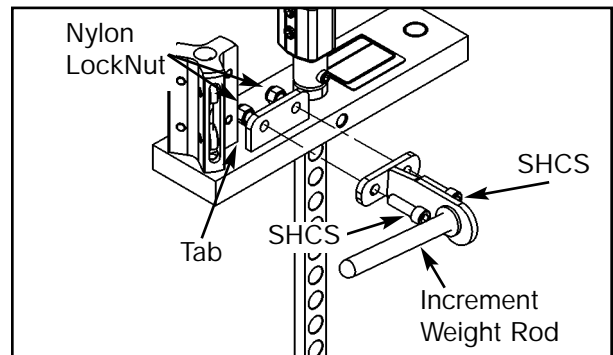

Figure 3

Cybox VR2 Owner's Manual

H. Wipe guide rods clean over entire length. Lubricate with light coating of medium weight automotive engine oil.

I. With an assistant present, carefully install each weight plate one at a time.

NOTE: For all machines except the Hip Abduction, Hip Adduction and Rotary Calf, lean guide rods toward weight stack guards when installing weight plates. For the Hip Abduction, Hip Adduction and Rotary Calf machines, lean guide rods away from the weight stack guard (toward the operator position).

J. Carefully slide top weight onto guide rods.

NOTE: Position top weight so that the tab is nearest the increment rod on the frame. See Figure 3 for location of tab.

K. On one of the guide rods, place lower snap ring and wave washer (removed in step 5) and wave washer at least two inches below top end of guide rod.

L. Raise guide rod up through mounting hole and install the upper snap ring into the top groove.

M. Lower guide rod and secure lower snap ring into the groove. Repeat steps 6K - 6M for the other guide rod.

NOTE: Be sure wave washer is between frame and lower snap ring. See Figures 1 and 2.

N. Place protective caps over the weight stack guide rod holes.

O. Place top weight increment rod onto the top weight and secure using two nylon locknuts and two SHCS .375-16 x 1.25. See Figure 3.

3. Belt Routing.

A. Carefully lift top weight and verify that the top weight belt clamp is parallel with the pulley bracket.

B. Verify that the SHCS securing belt clamp faces weight stack guard. See Figure 4.

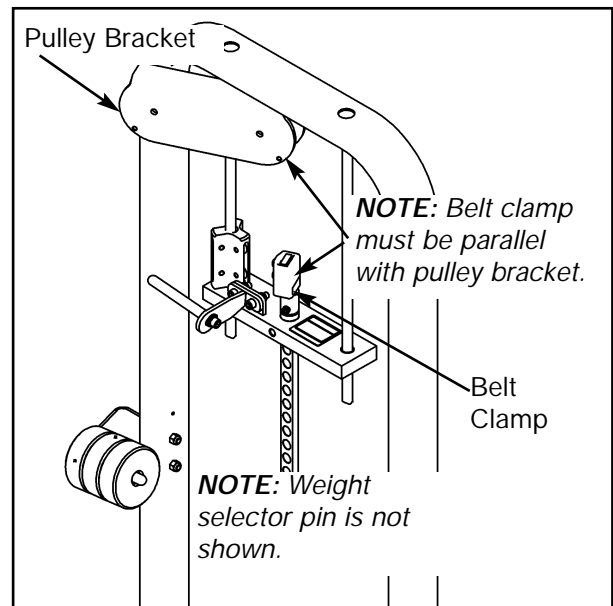

Figure 4

C. Route belt through top pulley bracket, making sure that the belt is routed on the outside of each pin as shown in Figure 5.

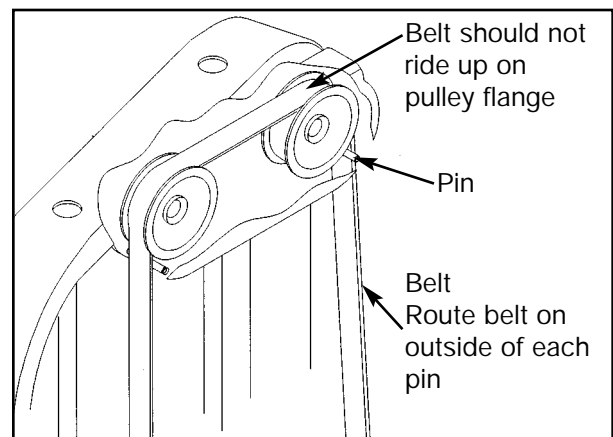
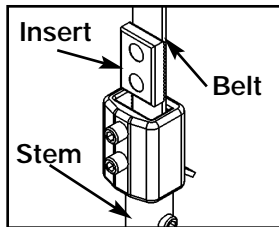

Figure 5

Cybox VR2 Owner's Manual

- D. Slide belt through slot in belt clamp.
- E. Verify belt and insert are installed properly, as shown in Figure 6. **NOTE: Do not install the insert backwards as shown in Figure 7.**



Correct belt routing

Figure 6

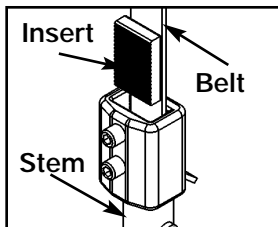

Wrong belt routing

Figure 7

- F. Pull belt tight and secure belt to clamp with the two set screws. See Figure 8.

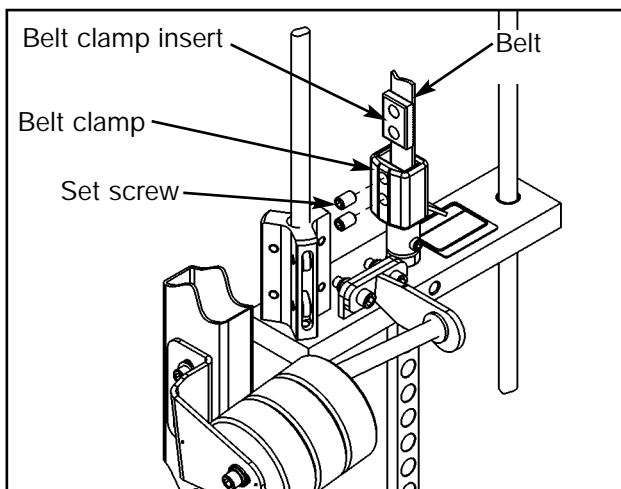

Figure 8

- G. Place weight stack pin in each plate to verify proper installation.
- H. Lift top weight up and down and verify that the belt lies flat and that it is not riding up on the pulley flange. See Figure 6.
- I. Verify belt is routed straight from the top pulley bracket to the top weight belt clamp.

4. Aligning increment weight rods.

- A. Securely tighten the SHCS securing the increment weight rod (located on the weight stack). See Figure 9.
- B. Securely tighten the SHCS securing the other increment weight rod. See Figure 9.

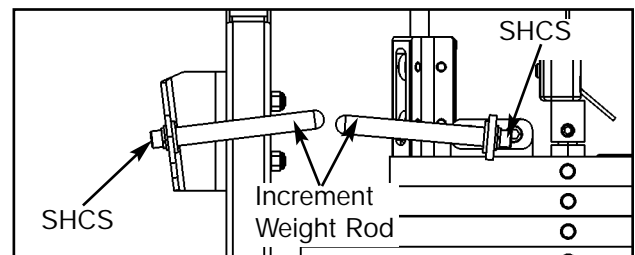

Figure 9

- C. Adjust the height of the increment weight rod (on the frame) to match the height of the increment weight rod on the top weight. Tighten each SHCS securely. See Figure 10.

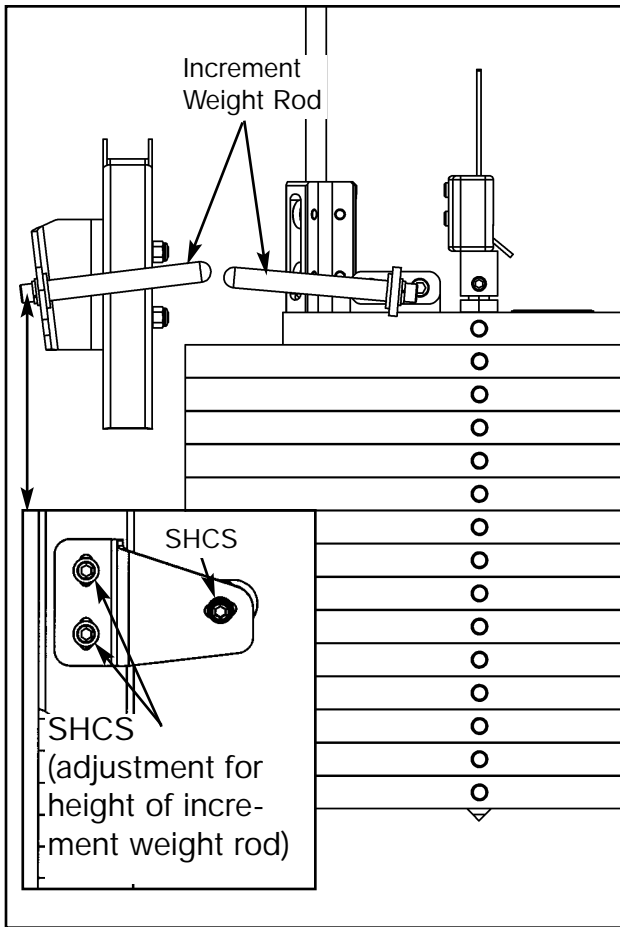

Figure 10

- D. Lift top weight and insert all three increment weights onto the increment weight rod (attached to the frame) then carefully lower the top weight.
- E. Verify increment weight rods are at the same height by sliding the increment weights from one increment weight rod to the other.

5. Install weight plate decals.

NOTE: Place weight plate decals (weight in pounds for standard units or if desired, number of weight plates for International units) on weight plates according to steps listed below and Figures 11 and 12.

- A. Slowly and carefully peel off back side of decal. **NOTE:** When peeling off back cover, make sure that the decals remain attached to the front sticker.

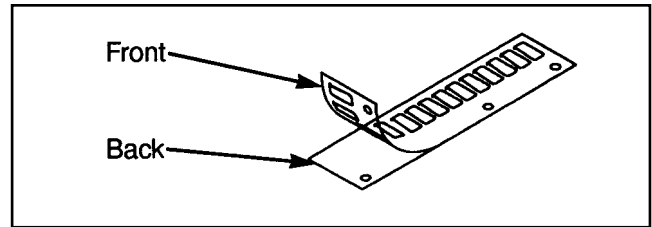

Figure 11

- B. Align holes in decal with appropriate holes in weight stack. **NOTE:** Do not allow the adhesive to touch weight stack at this time.
- C. Insert a guide pin through each hole of the template. **NOTE:** A guide pin can be anything that fits through the weight stack hole, such as a weight stack selector pin.
- D. Carefully align decal and rub it onto weight plates.
- E. Carefully remove front side, leaving decals adhering to weight plates.

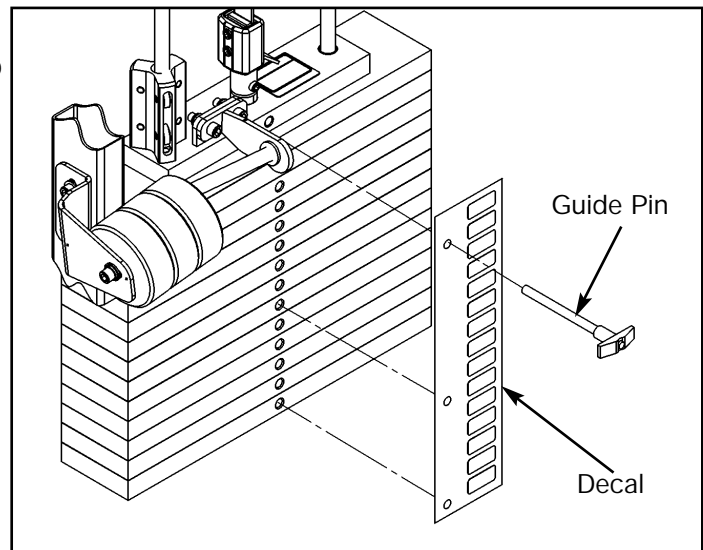

Figure 12

VR2 Top Weight

Product Number - VR2 Ower's Manual 54599

Addendum

This addendum includes the new VR2 Top Weight.

Please keep this addendum with your VR2 Owner's Manual, part number 54599.

VR2 Top Weight Chart (item #11 on next page)

4701-030

4526 SA Overhead Chest Press
4527 DA Overhead Press
4530 Lateral Raise
4535 Arm Curl
4540 Arm Extension
4545 Fly
4616/1617/1618 Leg Extension
4626/4627/4628 Seated Leg Curl
4640 Hip Adduction
4645 Hip Abduction
4705 Ab Crucnch
4715 Torso Rotation

4701-031

4506 SA Chest Press
4507 DA Chest Press
4511 SA Incline Press
4512 DA Incline Press
4515 DA Pulldown
4516 SA Lat Pulldown
4611/4612/4613 Leg Extension
4711/4712/4713 Back Extension

4701-032

4620 Rotary Calf

4701-033

4605 Seated Leg Press

4701-034

4520 DA Row/Rear Delt
4521 SA Row/Rear Delt

SA = Single Axis
DA = Dual Axis

Cyber VR2 Owner's Manual

00124 - Sliding Increment & Half Weight

ITEM	QTY	PART NO.	DESCRIPTION
1	1	11040-216	Belt Clamp
2	1	11040-301	Clamp Block Insert
3	3	4605-390	Increment Weight
4	1	51119	Selector Pin Retainer
5	1	BH030201	Quick Release Pin .375 Dia. x 4.00 Lg
6	2	HC702817	SHCS .375-16 x 1.00
7	2	HC702828	SHCS .375-16 x 2.25
8	4	HN704901	Nylon Locknut .375-16
9	4	HS347600	Washer SAE .375
10	1	4605-424	Caution Decal
11	1		Top Weight (See chart on previous page)
12	1	4700-240	Weight Mount
13	2	4700-318	Increment Weight Rod
14	1	4700-319	Increment Weight Frame Mount
15	2	4700-321	Rubber Washer
16	2	JC702820	SHCS .375-16 x 1.25
17	2	HS348300	Split Lockwasher .375
18	1	4701-001	Top Weight Guide
19	1	FB130208	Bearing Sleeve .68 x .81 1.00 Lg
20	3	HC702816	SHCS .375-16 x .875
21	3	HY740000	Set Screw

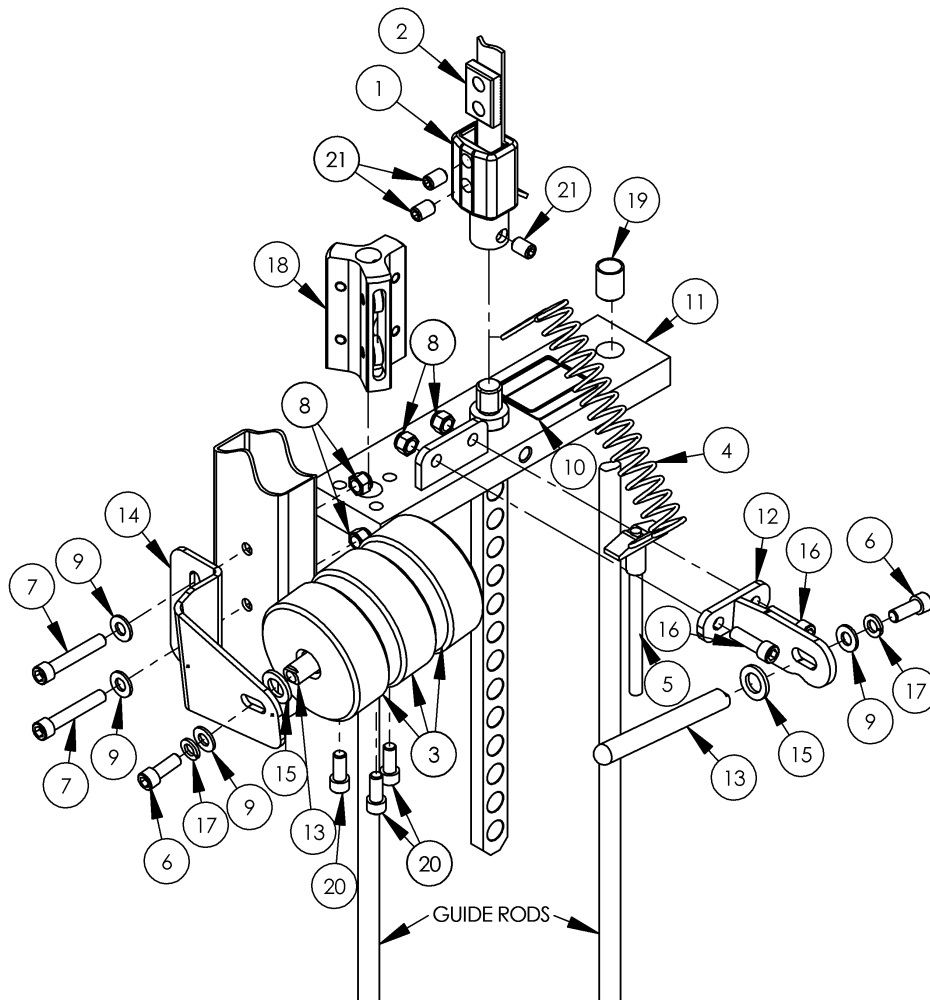

Chapter 6 - Maintenance

All preventive maintenance activities must be performed on a regular basis. Performing routine preventive maintenance actions can aid in providing safe, trouble-free operation of all CYBEX Strength Systems equipment.

NOTE: *CYBEX is not responsible for performing regular inspection and maintenance actions for your machines. Instruct all personnel in equipment inspection and maintenance actions and also in accident reporting/recording. CYBEX phone representatives are available to answer any questions or concerns that you may have.*



NOTE: *All inspections and repairs must be performed by trained service personnel only.*

Improper or incorrectly performed maintenance or repair voids this warranty.

Daily Procedures

1. **Upholstery** - Wipe down all upholstery as per the recommendations listed below for light soiling and more difficult stains.

Light Soiling

- A solution of 10% household liquid dish soap with warm water applied with a soft damp cloth.
- If necessary, a solution of liquid cleanser and water applied with a soft bristle brush. Wipe away the residue with a water dampened cloth.

Cybex VR2 Owner's Manual

More Difficult Stains

- Dampen a soft white cloth with a solution of household bleach (sodium hypochlorite), 10% bleach, 90% water. Rub gently. Rinse with a water dampened cloth to remove bleach concentration.
- The same procedure can be used with full strength household bleach, if necessary.
- Allow bleach to puddle on the affected area or apply with a soaked cloth for approximately 30 minutes. Rinse with a water dampened cloth to remove any remaining bleach concentration.

Alternative Method for Difficult Stains

- Dampen a soft white cloth with rubbing alcohol and rub gently. Rinse with a water dampened cloth to remove any remaining rubbing alcohol concentration.

NOTE: *To restore luster, a light coat of spray furniture wax can be used. Apply for 30 seconds and follow with a light buffing using a clean white cloth.*

Please Review Carefully

When using strong cleaning agents such as rubbing alcohol or bleach, it is advisable to first test in an inconspicuous area. Other cleaning agents may contain harsh or unknown solvents and are subject to formula changes by the product manufacturer without notice. Should you desire to use other cleaning agents, carefully try them in an inconspicuous area to determine potential damage to the material. Never use harsh solvents or cleaners which are intended for industrial applications. To clean stained or soiled areas, a soft white cloth is recommended. Avoid use of paper towels.

Cleaning products may be harmful/irritating to your skin, eyes, etc. Use protective gloves and eye protection. Do not inhale or swallow any cleaning product. Protect surrounding area/clothing from exposure. Use in a well ventilated area. Follow all product manufacturer's warnings. CYBEX and its vendors cannot be held responsible for damage or injuries resulting from the use or misuse of cleaning products.

2. **Frames** - Wipe down all frames using a mild solution of warm water and car wash soap. Be sure to dry thoroughly. **AVOID** acid or chlorine based cleaners and also cleaners containing abrasives as these could scratch or damage the equipment.
3. **Chrome** - Clean chrome tubes, first using chrome polish and then using a car wax seal. Neutral cleaners with a pH between 5.5 and 8.5 are recommended. Be sure to dry thoroughly. **AVOID** acid or chlorine based cleaners and also cleaners containing abrasives as these could scratch or damage the equipment.

Weekly Procedures

1. Check all nuts and bolts for looseness. Tighten as required.
2. Inspect all belts (entire length) for any *non-uniformity and wear*.

Immediately replace belt if any of the following conditions are present:

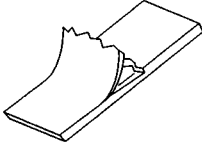
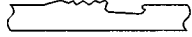
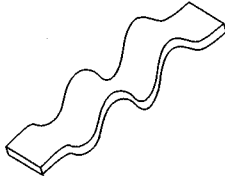
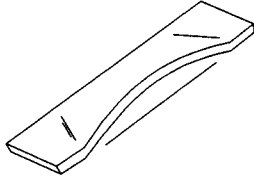
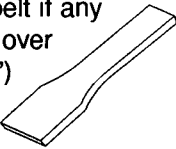
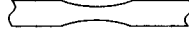
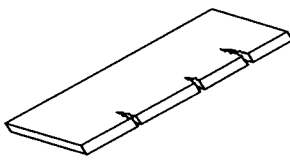
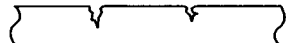
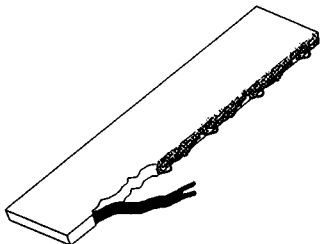
	3D View	3D or Side View
<ul style="list-style-type: none"> • Peeling of the belt's skin. 		
<ul style="list-style-type: none"> • Wave in the belt. 		
<ul style="list-style-type: none"> • Belt is necked down (narrow section). 	<p>Replace belt if any section is over 1/32" (.03") narrower than rest of the belt.</p> 	 <p>Examine edge of belt (both sides). Replace belt if any section is narrower than the rest.</p>
<ul style="list-style-type: none"> • Cracks or splits. 		
<ul style="list-style-type: none"> • One or more strands of kevlar hanging out. NOTE: Also replace belt if there is a significant amount of frayed kevlar. 		

Cybex VR2 Owner's Manual

3. Some machines, such as the Fly, Hip Adduction and Hip Abduction, use cables in addition to belts. Inspect all cables for wear or damage and proper tension. When inspecting cables, run your fingers on the cable, paying particular attention to bends in the cable and attachment points.

Replace all worn cables immediately. The following conditions may indicate a worn cable:

- A tear or crack in the cable sheath that exposes the cable. See Figure 1

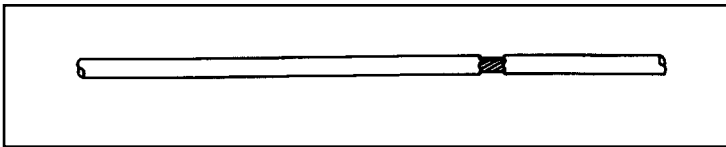

Figure 1

- A kink in the cable. See Figure 2.

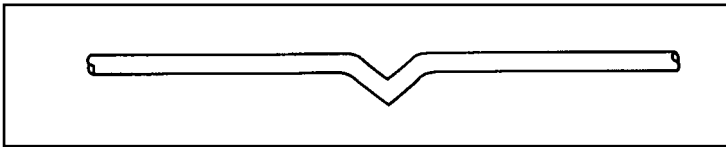

Figure 2

- A curled sheath. See Figure 3.

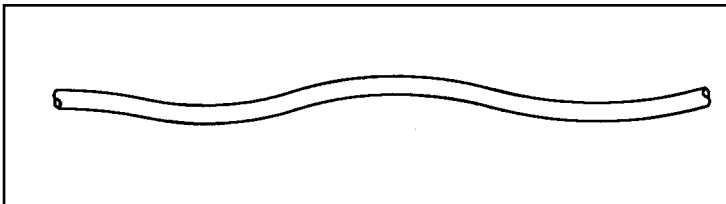

Figure 3

- "Necking", a stretched cable sheath. See Figure 4.

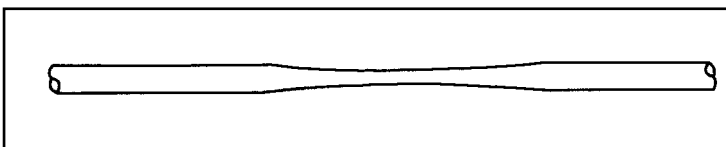

Figure 4

Cybox VR2 Owner's Manual

4. Inspect bars and handles for wear, paying particular attention to tab area connecting points.

Replace all worn handles immediately.

5. Inspect snap links for proper latching (indicates wear).

Replace all worn snap links immediately.

6. Inspect all labeling for readability. This includes instructional placards, warning and caution decals.

Replace all worn labeling immediately.

7. Inspect all weight stacks for proper alignment and operation.

Correct all improper alignment and operation issues immediately.

8. Wipe *Weight Stack Guide Rods* clean over entire length. Lubricate with a light coat of medium weight automotive engine oil.

Yearly Procedures

1. Replace all belts and cables at least annually.

"As Required" Procedures

1. Inspect grips and replace as necessary.

Cybex VR2 Owner's Manual

(This page intentionally left blank)

Chapter 7 - Service

General

This section contains a recommended belt installation and removal, grip replacement procedure, pivot shaft installation and removal, as well as service information for each machine. See the caution statement shown below when replacing parts.

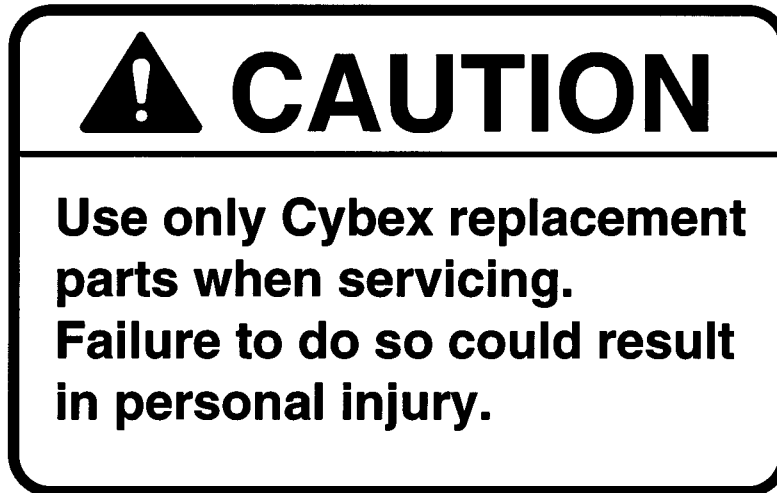

NOTE: All inspections and repairs must be performed by trained service personnel only.

Improper or incorrectly performed maintenance or repair voids this warranty.

Cybex VR2 Owner's Manual

(This page intentionally left blank)

Belt Removal

1. Place quick release pin (weight stack selector pin) into the top weight plate. Also place increment weight(s) onto the increment weight holder, if applicable.
2. Using a 5/16" Allen wrench, remove the screws securing clamp at one end of the belt.
3. Remove the screws securing clamp at the other end of the belt and remove belt.

Belt Installation

1. Observe the four types of belt clamps used on the VR2 machines (shown below). Familiarize yourself with the types you will be working with.

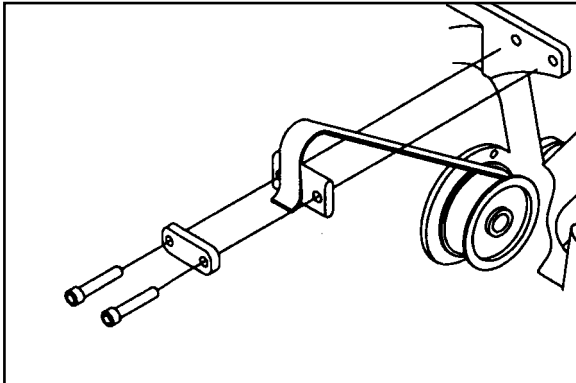

Sandwich Connection (Frame)

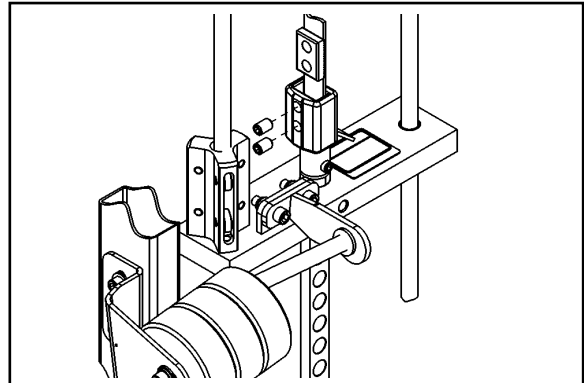

Weight Stack Connection

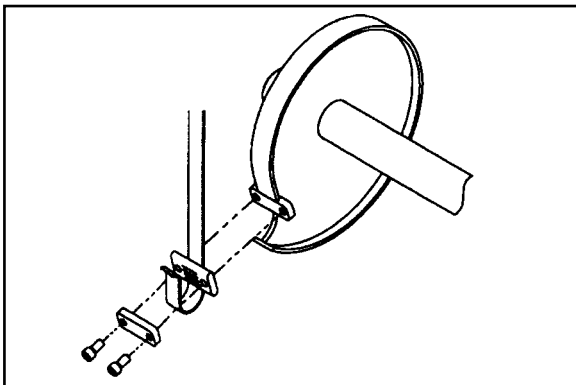

Sandwich Connection (Cam)

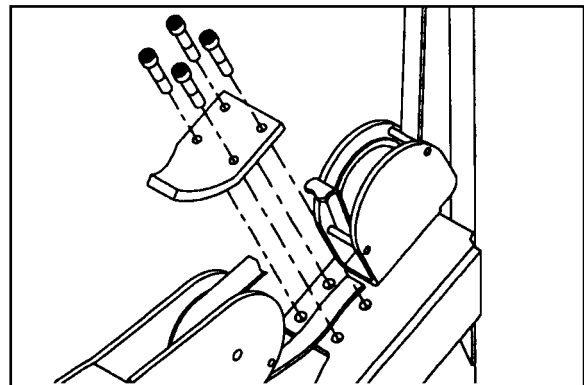

Rotary Calf Connection

Cybex VR2 Owner's Manual

NOTE: Steps 2 - 5 are for replacing a belt that connects from a cam or frame sandwich clamp to another cam or frame sandwich clamp.

- 2 **A.** Review the belt routing and clamping diagrams for the machine you are working on. These diagrams can be found on the appropriate Parts List (and service diagrams) located at the end of this chapter.

- B.** Place screws through outside and center clamps. Loosely tighten screws into frame about two turns. See the Sandwich Connection (Frame) diagram at right.

- C.** Slide belt between frame and center clamps.

- D.** Fold belt around center clamp and slide belt between the center and outside clamps.

- E.** Pull belt tight against the radius, leaving 1 to 2 inches of belt beyond the clamp.

- F.** Center the belt between the clamp screws. An exception to this is when a pulley is located close to a clamp, then the belt may be off centered. The belt must be in a straight line with the pulley or cam. See Belt and Clamp Alignment diagram at right.

- G.** Tighten screws (alternate until each screw is tight) so that the clamps are parallel with each other. The gap (A) shown in the Belt and Clamp Alignment diagram, should be the same distance at each end of the clamp. Likewise, gap (B) should be the same distance at each end of the clamp. **NOTE: The torque specification for tightening each screw is 400 inch pounds.**

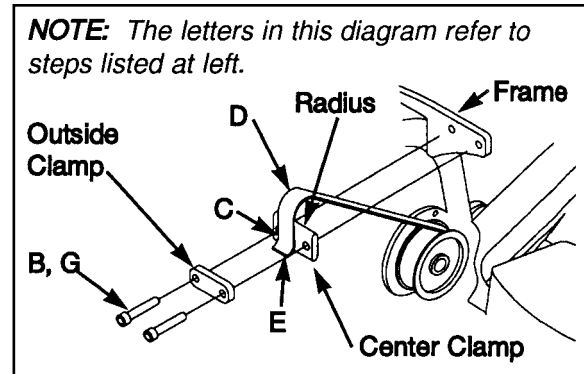

Sandwich Connection (Frame)

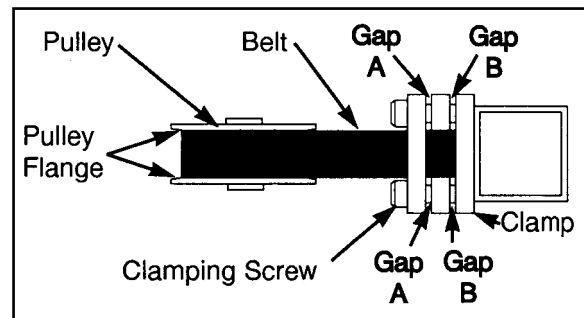

Belt and Clamp Alignment

3. Route the belt as shown in the appropriate belt routing diagram (located at the end of this chapter). **NOTE: Be sure belt is routed on outside edge of pin as shown in the Routing Belt diagram at right.**
4. Clamp other end of belt as described in step 2. For proper belt tension, refer to the belt clamping diagram (see step 2A).

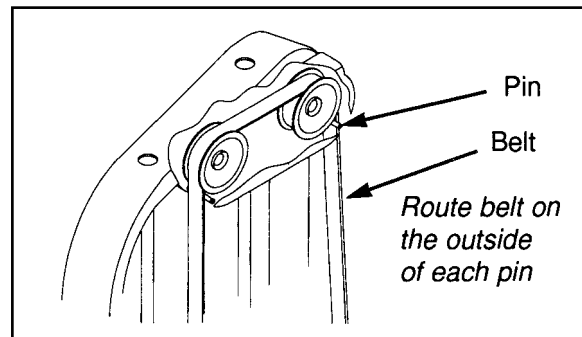

Routing Belt

5. Lift top weight up and down and verify that the belt lies flat and that it is not riding up on the pulley flange.

NOTE: Steps 6 - 10 are for replacing a belt that connects from a cam or frame sandwich clamp to top weight clamp.

6. Before attaching belt to top weight clamp, attach other end of belt to the sandwich clamp as stated in steps 2 and 3. **NOTE: For Rotary Calf machines, clamp and route belt as shown in the belt routing diagram for the Rotary Calf. Also see step 2F on page 7-4.**

7. Attach belt to top weight:

A. Slide belt through slot in belt clamp.
NOTE: The belt must be inserted into the slot that is located directly over the stem.

B. While holding belt (and keeping it straight), insert the belt clamp insert, leaving 1 to 2 inches of belt beyond the clamp as shown in the diagram at right.

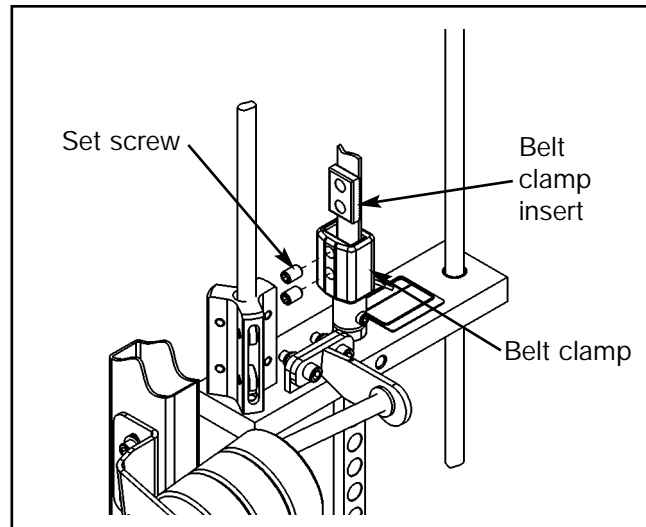

Installing Belt Clamp Insert

8. While keeping belt straight, insert each SHCS into the belt clamp and belt clamp insert, and then adjust belt (to remove slack) so that the top plate is just resting on the second weight. Securely tighten each SHCS after belt is properly adjusted. **NOTE: The torque specification for tightening each screw is 400 inch pounds.**

9. Place weight stack selector pin in each plate to verify proper installation.

10. Lift top weight up and down and verify that the belt lies flat and that it is not riding up on the pulley flange.

Grip Replacement

Replace worn grips.

1. Remove grip by carefully cutting it using a utility knife.
2. Spray handle with solution of warm water and mild detergent and soak grip in same solution.
3. Slide grip onto bar.

Pivot Shaft Removal

If for any reason you need to remove a pivot shaft, then perform the following steps:

NOTE: It is important that you do not pound on the flat surface of the shaft. Doing so will damage the shaft and will make the task of removing or reinstalling the pivot shaft much more difficult or impossible.

1. Remove snap ring from pivot shaft.

NOTE: If pivot shaft contains a hole at one end, then remove snap ring from end of pivot shaft containing the hole. Otherwise, remove snap ring from either end (of shorter pivot shafts that do not contain a hole).

2. Using your thumb, push pivot shaft out. If pivot shaft does not slide out, then place a punch in the hole end of the pivot shaft and tap the shaft out using a rubber mallet.

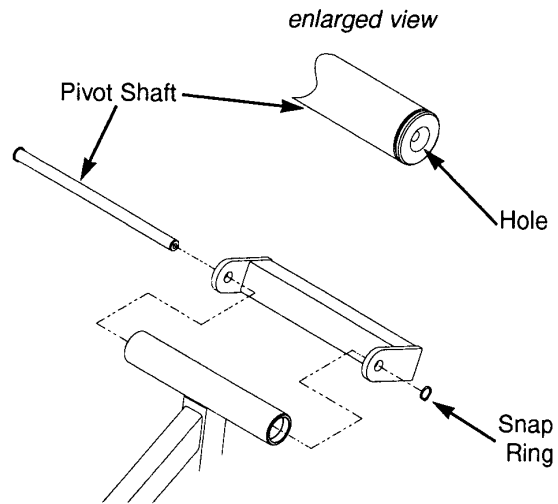

Pivot Shaft Installation

1. Slide pivot shaft (end with the hole) into the pivot shaft hole.
2. Slide pivot shaft into position. If needed, use an alignment tool, such as a punch or screw driver, place alignment tool into the hole of the pivot shaft, and slide pivot shaft into position.
3. Replace snap ring.

CHEST PRESS - SINGLE AXIS

PRODUCT NO. 4506

PARTS LIST

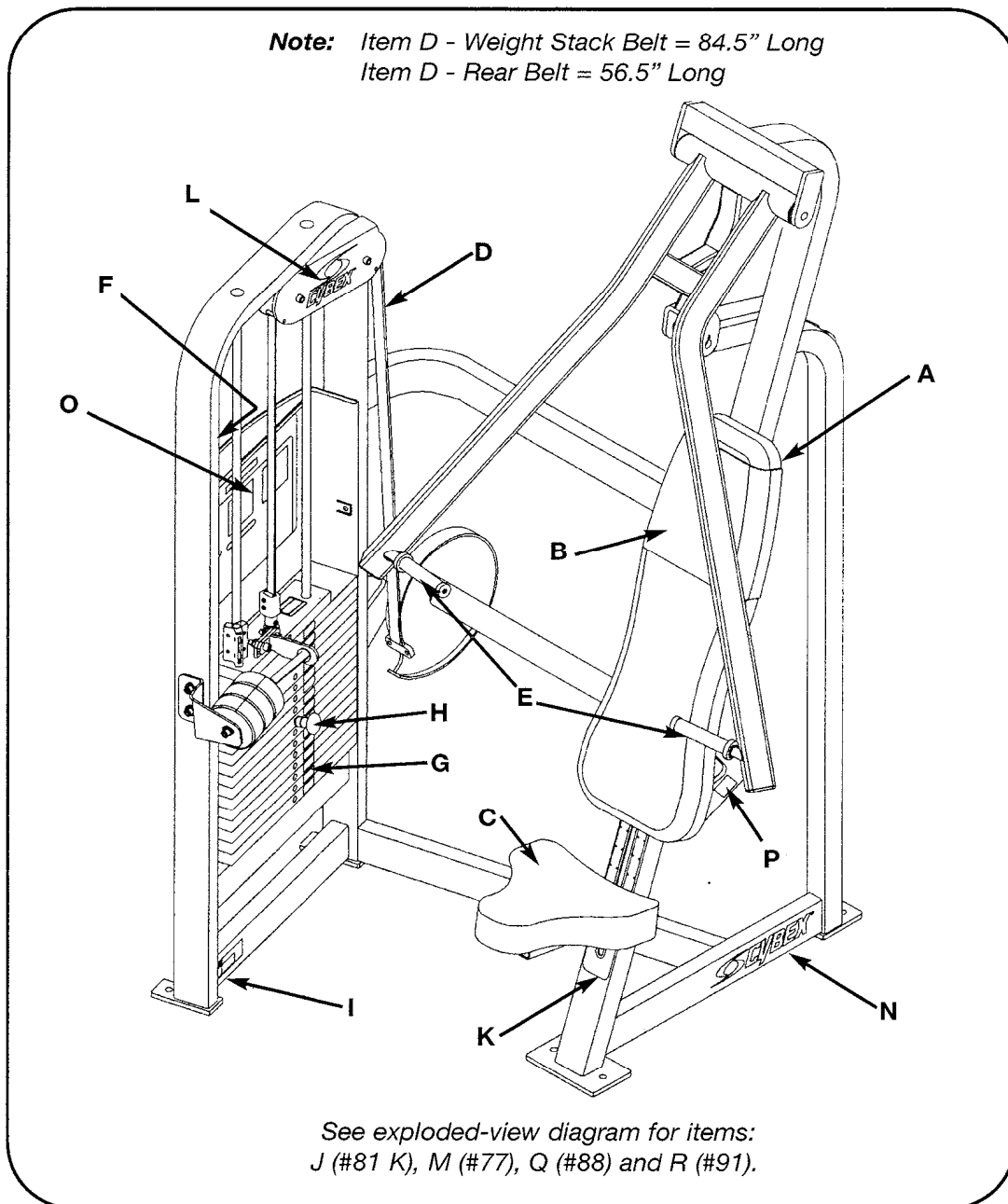

DESCRIPTION	PART NO.	DESCRIPTION	PART NO.
A. Back Cushion w/Wear Cover.....	4800-103	K. Seat Adjustment Decal..	5221-316
B. Wear Cover.....	4800-106	L. Cybex Decal Blk/Plm	3900-423
C. Seat Cushion.....	4800-026	L. Cybex Decal Wht/Wht ..	3900-424
D. Belt	GB000202	M. Cybex Decal Blk/Plm	3900-439
E. Grip.....	4605-507	M. Cybex Decal Wht/Wht...	3900-440
F. Warning Decal	4605-381	N. Cybex Decal Blk/Plm.....	3900-390
G. Weight Plate Decal	4605-388	N. Cybex Decal Wht/Wht...	3900-415
H. Weight Selector Pin.....	BH030207	O. Placard Decal	4506-598
I. Serial Number Decal		P. Caution Decal	4000Y316
J. Caution Decal.....	4605-424	Q. Adjusting Decal	4506-313
		R. Caution Decal.....	4520-362

4506 - Chest Press - Single Axis

ITEM	QTY	PART NO.	DESCRIPTION	ITEM	QTY	PART NO.	DESCRIPTION
1	1	11040-440	Cybox Knob	66			Not Used
2	1	4505-212	Adjusting Tube (outer)	67	1	PN660201	Hole Plug
3	1	4506-204	Adjusting Tube (inner)	68	1	PP090202	Plastic Insert 1.50 x 3.00 x 11 G
4	1	4506-202	Cam	69	2	PP090210	Plastic Insert 2.00 Sq, x 10-14 G
5	1	4505-207	Seat	70	1	PP090211	Plastic Insert 1.50 Sq, x 10-14 G
6	1	4506-200	Frame	71			Not Used
7			Not Used	72			Not Used
8	1	4505-327	Pivot Shaft 35.72	73	2	4605-507	Grip 6.5" Long
9	1	4505-329	Detent Pin	74	1	4505-331	Bumper 1.50 Dia
10	1	PR070001	Foot Pad 2.40 x 4.25	75	1	4800-026	Seat Cushion
11	1	4605-512	Plastic Insert 7.94	76 A	1	4800-009	Backrest Cushion w/Wear Cover
12	1	4505-335	Belt Stop Plate	76 B	1	4800-092	Wear Cover
13	1	4505-432	Guard	77			Removed 3/03
14	1	4506-203	Arm Bearing Housing	77	1	3900-439	Cybox Decal 11.37 Vert. Blk/Plm
15	1	4506-598	Placard Decal	77	1	3900-440	Cybox Decal 11.37 Vert. Wht/Wht
16	1	4520-212	Seat Roller	78			Removed 3/03
17	2	4520-331	Roller	78	1	3900-390	Cybox Decal 1.57 Horiz. Blk/Plm
18			Removed	78	1	3900-415	Cybox Decal 1.57 Horiz. Wht/Wht
19			Not Used	79	1	3900-423	Cybox Decal 4.85 Vert. Blk/Plm
20			Not Used	79	1	3900-424	Cybox Decal 4.85 Vert. Wht/Wht
21	1	PR070002	Foot Pad 4.00 x 7.00	79			Removed 3/03
22	1	5221-316	Seat Adjustment Decal	80	1	4701-021	Weight Stack Guide Rod Set
23			Not Used	80 A	2	4505-319	Weight Stack Guid Rod
24			Not Used	80 B	4	BR030214	Retaining Ring .625
25	3	4605-300	Belt Clamp	80 C	2	HS407100	Spring Washer .65 x .79 x .062 T
26	1	4605-334	Pivot Shaft 13.06	80 D	2	PN660200	Plastic Insert 1.00 Dia x 11 G
27			Not Used	80 E	2	PR060005	Weight Bumper
28	2	PR070003	Foot Pad 2.00 x 5.25	81	1	4701-031	Sliding Increment Weight Set
29	2	11090-374	End Cap	81 A	1	11040-216	Belt Clamp
30	1	4605-373	Pivot Shaft 4.06	81 B	1	11040-301	Belt Clamp Insert
31	1	4605-381	Warning Decal	81 C	3	4605-390	Increment Weight
32			Not Used	81 D			Removed 3/03
33			Not Used	81 E	1	BH030207	Weight Selector Pin
34	1	4605-388	Weight Plate Decal 10-290	81 F	1	4701-001	Top Weight Guide
35			Not Used	81 G	2	HC702817	SHCS .375-16 x 1.00
36	3	4605-394	Belt Clamp	81 H	2	HC702828	SHCS .375-16 x 2.25
37			Not Used	81 I	4	HN704901	Nylon Locknut .375-16
38			Not Used	81 J	4	HS347600	Washer, SAE .375
39			Not Used	81 K	3	HY740000	Set Screw
40	1	4701-302	VR2 Weight Stack Instr. (not shown)	81 L	1	4605-424	Caution Decal
41			Not Used	81 M	1	4700-240	Weight Mount
42			Not Used	81 N	2	4700-318	Increment Weight Rod
43	6	BR030210	Retaining Ring 17 mm	81 O	1	4700-319	Frame Mount Increment Weight
44			Not Used	81 P	1	FB130208	Bearing Sleeve .68 x .81 1.00 L
45	1	BS070201	Com Spring .56 x .66 x 1.50 L	81 Q	2	4700-321	Rubber Washer
46			Not Used	81 R	2	JC702820	SHCS .375-16 x 1.25
47	4	FB030232	Radial Bearing 17 mm ID (Ext Race)	81 S	2	HS348300	Split Lockwasher .375
48	2	FB130207	Flange Bearing 17mm x19mm x 25mm	81 T	1	4700-238	Top Weight
49 A	84.5"	GB000202	Weight Stack Belt .95" Wide	81 U	3	HC702816	SHCS .375-16 x .875
49 B	56.5"	GB000202	Rear Belt .95" Wide	82	1	51198	Strength Warranty Sheet (not shown)
50	3	GP000209	Pulley Assembly 3.50	83			Not Used
51			Not Used	84	1	HP707017	Stud .375-16 x 1.00
52	2	HC702817	SHCS .375-16 x 1.00	85	2	HF449063	Connector Insert .75 x .25-20
53	6	HC702822	SHCS .375-16 x 1.50	86	2	4000Y316	Caution Decal
54			Not Used	87	2	HC702834	SHCS .375-16 x 3.00
55	5	HC702830	SHCS .375-16 x 2.50	88	1	4506-313	Adjusting Decal
56	3	HN704901	Locknut .375-16 Nylon	89	2	PP080207	Plastic Insert
57	1	HP266717	Spiral Pin .125 x 1.00	90	1	4520-213	Bracket
58			Removed	91	1	4520-362	Caution Decal
59			Removed	92	2	HS347700	Washer USS .375
60			Not Used	93	2	JC702812	SHCS .375-16 x .50
61			Not Used	94	14	4000C101	Stack Weight 4 x 18 (not shown)
62	4	HT102214	Tap Screw #10-12 x .625 A (Phil)	95	4	JS347400	Internal Tooth Lockwasher .375
63	1	JC702814	SHCS .375-16 x .625	96	2	11090-376	Handle Grip Ring
64			Not Used	97	2	JC620422	BHSCS .250-20 x 1.50
65			Removed				

CHEST PRESS - SINGLE AXIS - 4506

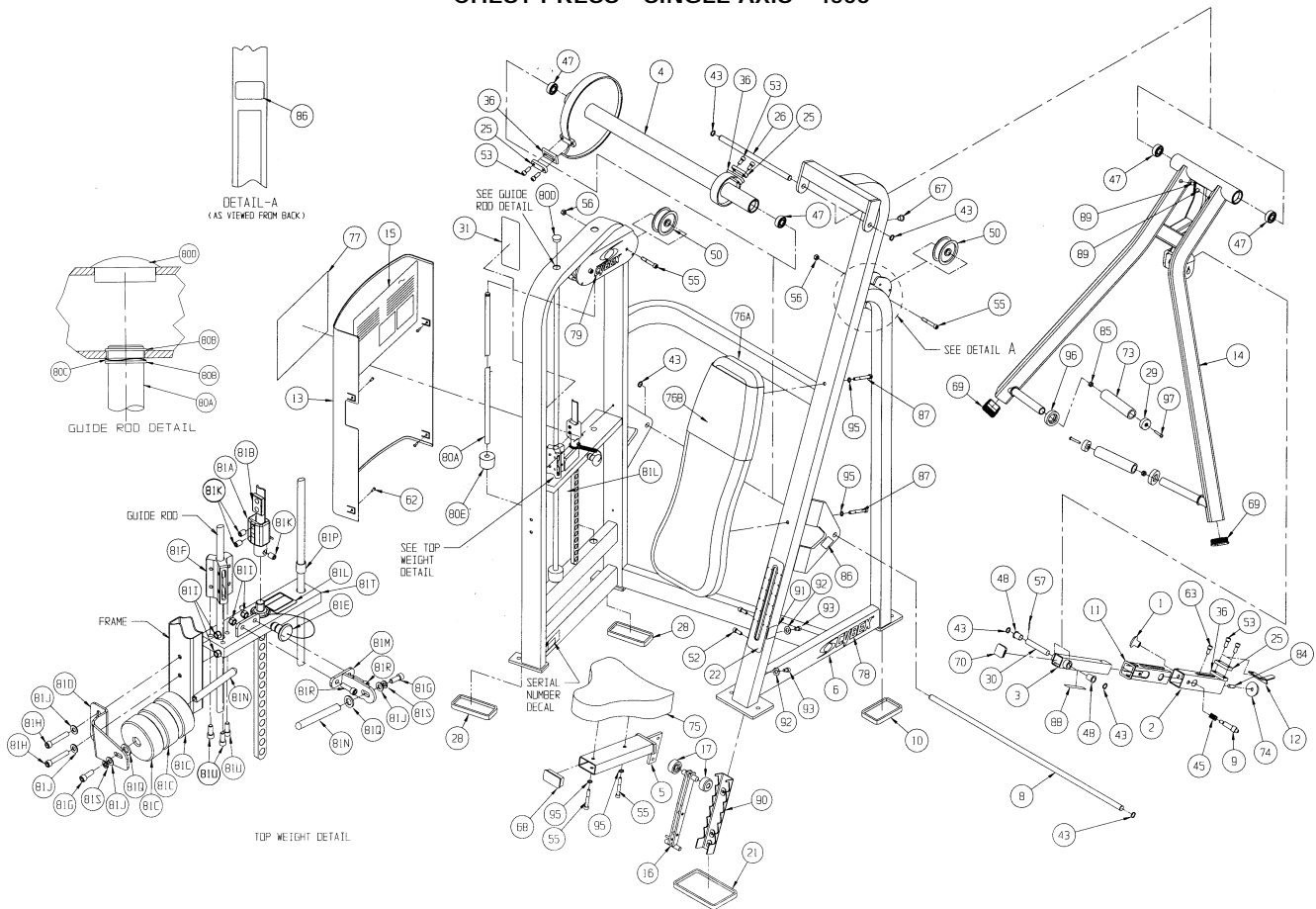

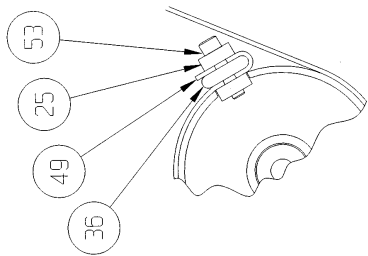

BELT CLAMPING DETAIL

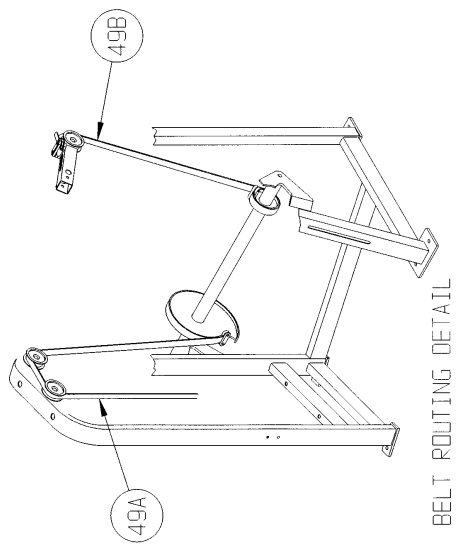

BELT ROUTING DETAIL

CHEST PRESS - DUAL AXIS

PRODUCT NO. 4507

PARTS LIST

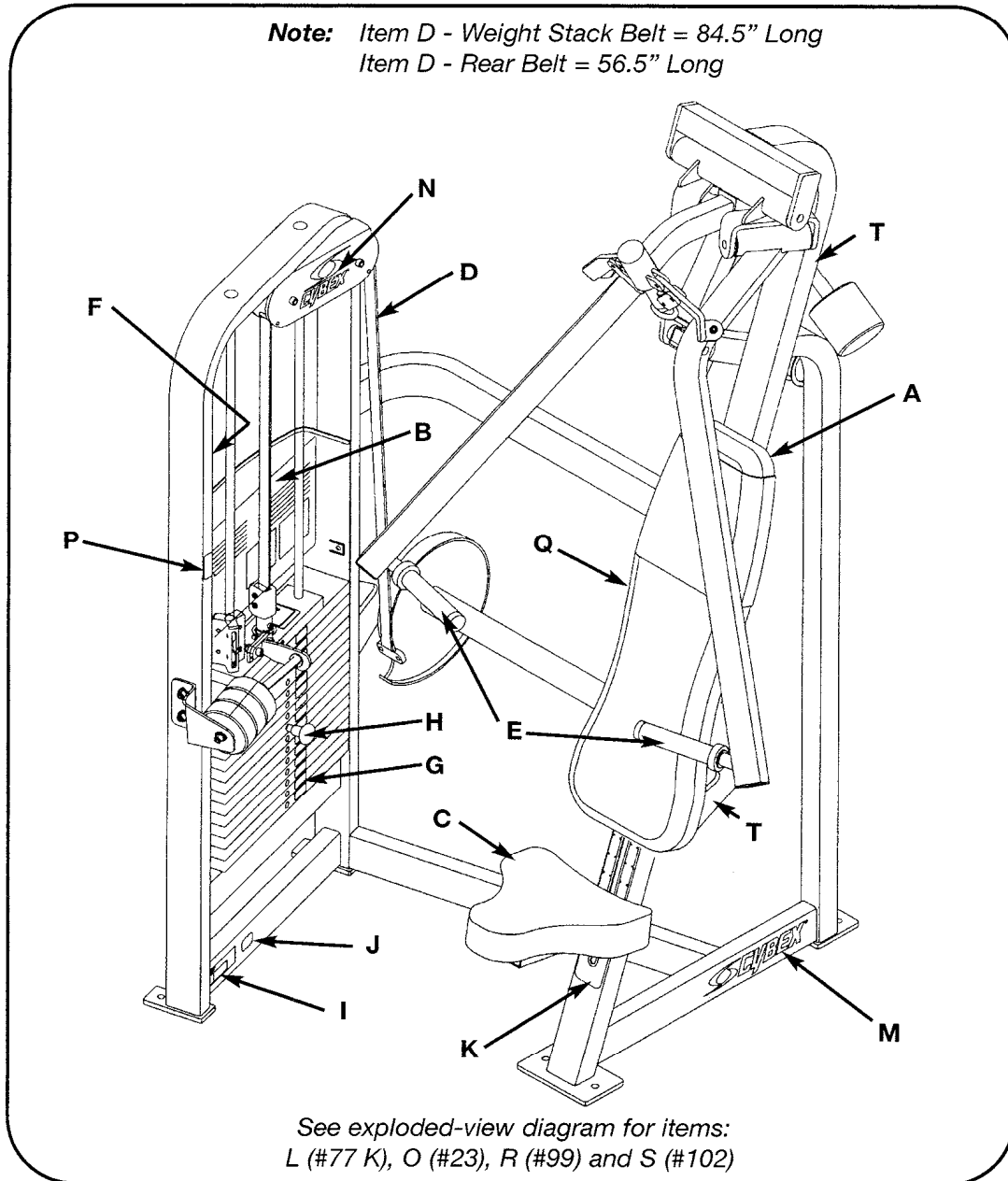

DESCRIPTION	PART NO.	DESCRIPTION	PART NO.
A. Back Cushion w/Wear Cover.....	4800-103	L. Caution Decal.....	4605-424
B. Placard Decal.....	4507-598	M. Cybex Decal Blk/Plm	3900-390
C. Seat Cushion.....	4800-026	M. Cybex Decal Wht/Wht...	3900-415
D. Belt.....	GB000202	N. Cybex Decal Blk/Plm	3900-423
E. Grip	4605-500	N. Cybex Decal Wht/Wht...	3900-424
F. Warning Decal.....	4605-381	O. Cybex Decal Blk/Plm	3900-439
G. Weight Plate Decal	4605-388	O. Cybex Decal Wht/Wht...	3900-440
H. Weight Selector Pin.....	BH030207	P. Caution Decal	5221-319
I. Serial Number Decal		Q. Wear Cover (Item A)	4800-106
J. Patent Pending Decal ...	CM000211	R. Adjusting Decal	4506-313
K. Seat Adjustment Decal..	5221-316	S. Caution Decal.....	4520-362
		T. Caution Decal.....	4000Y316

4507 - Chest Press - Dual Axis

ITEM	QTY	PART NO.	DESCRIPTION
1	1	11040-440	Cybex Knob
2 A	1	4800-103	Back Cushion w/Wear Cover
2 B	1	4800-106	Wear Cover
3	1	4506-200	Frame
4	1	4507-204	Bearing Housing
5	1	4505-202	Arm (Right Hand)
6	1	4505-203	Arm (Left Hand)
7	1	4505-212	Adjusting Tube (Outer)
8	1	4506-204	Adjusting Tube (Inner)
9	1	4506-202	Cam
10	1	4505-207	Seat
11	2	4505-318	Counterweight
12	1	4701-021	Weight Stack Guide Rod Set
12 A	2	4505-319	Weight Stack Guide Rod
12 B	4	BR030214	Retaining Ring .625
12 C	2	HS407100	Spring Washer .65 x .79 x .062 T
12 D	2	PN660200	Plastic Insert 1.00 Dia x 11 G
12 E	2	PR060005	Weight Bumper
13	1	4507-598	Placard Decal
14	1	4505-327	Pivot Shaft 35.72
15	1	4505-329	Detent Pin
16	1	PR070001	Rubber Foot Cover 4.84 x 3.09
17	3	4505-331	Bumper 1.50 Dia
18			Removed
19	1	4520-212	Seat Roller
20	2	4520-331	Roller
21			Removed
22			Removed 3/03
22	1	3900-390	Cybex Decal 1.57 Horiz. Blk/Plm
22	1	3900-415	Cybex Decal 1.57 Horiz. Wht/Wht
23			Removed 3/03
23	1	3900-439	Cybex Decal 11.37 Vert. Blk/Plm
23	1	3900-440	Cybex Decal 11.37 Vert. Wht/Wht
24	1	PR070002	Rubber Foot Cover 7.65 x 4.59
25	1	4800-026	Seat Cushion
26			Removed
27	3	4605-300	Belt Clamp
28	1	4605-334	Pivot Shaft 13.06
29	2	PR070003	Rubber Foot Cover 5.25 x 2.00
30	2	4605-550	Plug
31	1	4605-373	Pivot Shaft 4.06
32	2	5220-320	Pivot Shaft 7.06
33	10	BR030210	Retaining Ring 17 mm
34			Not Used
35	1	BS070201	Com Spring .56 ID x .66 OD x 1.50 L
36			Not Used
37	8	FB030232	Radial Bearing 17 mm ID (Ext Race)
38	2	FB130207	Flange Bearing 17 mm x 19 x 22
39 A	84.5"	GB000202	Weight Stack Belt .95" Wide
39 B	56.5"	GB000202	Rear Belt .95" Wide
40	3	GP000209	Pulley Assembly 3.50
41	2	HC702815	SHCS .375-16 x .750
42			Not Used
43	5	HC702830	SHCS .375-16 x 2.50
44	2	HC702834	SHCS .375-16 x 3.00
45			Not Used
46	1	HP266717	Roll Pin .125 x 1.00
47			Removed
48			Not Used
49	1	PN660201	Hole Plug
50	1	3900-423	Cybex Decal 4.85 Vert. Wht/Wht
50	1	3900-424	Cybex Decal 4.85 Vert. Blk/Plm
50			Removed 3/03
51	1	PP090202	Plastic Insert 1.50 x 3.00 x 11 G
52	2	PP090210	Plastic Insert 2.00 Sq x 10-14 G
53			Removed
54	2	4605-500	Grip
55	1	51198	Strength Warranty Sheet (not shown)
56	1	4505-335	Belt Stop Plate
57	1	4505-432	Guard
58	1	4605-381	Warning Decal

ITEM	QTY	PART NO.	DESCRIPTION
59	6	4507-301	Pin
60	4	4507-302	Link Bar
61			Removed
62			Not Used
63	4	HT102214	Tap Screw #10-12 x .625 A (Phil)
64	1	4507-306	Adjustment Screw
65	1	PP090211	Plastic Cap 1.625 ID
66			Not Used
67			Not Used
68	1	4605-388	Weight Plate Decal 10 - 290
69			Not Used
70			Removed
71			Not Used
72			Not Used
73			Not Used
74	1	JC702814	SHCS .375-16 x .625
75	6	HC702822	SHCS .375-16 x 1.50
76			Not Used
77	1	4701-031	Sliding Increment Weight Set
77 A	1	11040-216	Belt Clamp
77 B	1	11040-301	Belt Clamp Insert
77 C	3	4605-390	Increment Weight
77 D			Removed 3/03
77 E	1	BH030207	Weight Selector Pin
77 F	1	FB130208	Bearing Sleeve .68 x .81 1.00 L
77 G	2	HC702817	SHCS .375-16 x 1.00
77 H	2	HC702828	SHCS .375-16 x 2.25
77 I	4	HN704901	Nylon Locknut .375-16
77 J	4	HS347600	Washer, SAE .375
77 K	3	HY740000	Set Screw
77 L	1	4605-424	Caution Decal
77 M	1	4700-240	Weight Mount
77 N	2	4700-318	Increment Weight Rod
77 O	1	4700-319	Frame Mount Increment Weight
77 P	1	4701-001	Top Weight Guide
77 Q	2	4700-321	Rubber Washer
77 R	2	JC702820	SHCS .375-16 x 1.25
77 S	2	HS348300	Split Lockwasher .375
77 T	1	4700-238	Top Weight
77 U	3	HC702816	SHCS .375-16 x .875
78	1	5221-316	Seat Adjustment Decal
79	3	4605-394	Belt Clamp
80			Not Used
81			Not Used
82			Removed 5/99
83			Not Used
84	2	FB130212	Flange Bearing .75 x .88 x .75 L
85	1	PP460012	Textured Knob .375-16 (male)
86	12	08017	Retaining Ring .375
87	2	HS347700	Washer .375 USS
88	1	4507-201	Slide
89	1	4507-202	Stop (RH)
90	1	4507-203	Stop (LH)
91	1	4507-310	Flat Washer .647 x 1.250 x .105 T
92	1	HP707017	Stud .375-16 x 1.00 L
93	1	JC700914	FHSCS .375-16 x .62
94	1	PP090208	Plastic Insert
95	1	5221-319	Caution Decal
96	2	HF449063	Connector Insert .75 x .25-20
97	2	PP080207	Plastic Insert .437 Dia x 11 G
98	1	4605-512	Plastic Insert
99	1	4506-313	Adjusting Decal
100	1	4701-302	VR2 Weight Stack Instr. (not shown)
101	1	4520-213	Bracket
102	1	4520-362	Caution Decal
103	2	HS347700	Washer USS .375
104	2	JC702812	SHCS .375-16 x .50
105	14	4000C101	Stack Weight 4 x 18 (not shown)
106	2	4000Y316	Caution Decal
107	4	JS347400	Internal Tooth Lockwasher .375
108	2	11090-376	Handle Grip Ring

CHEST PRESS - DUAL AXIS - 4507

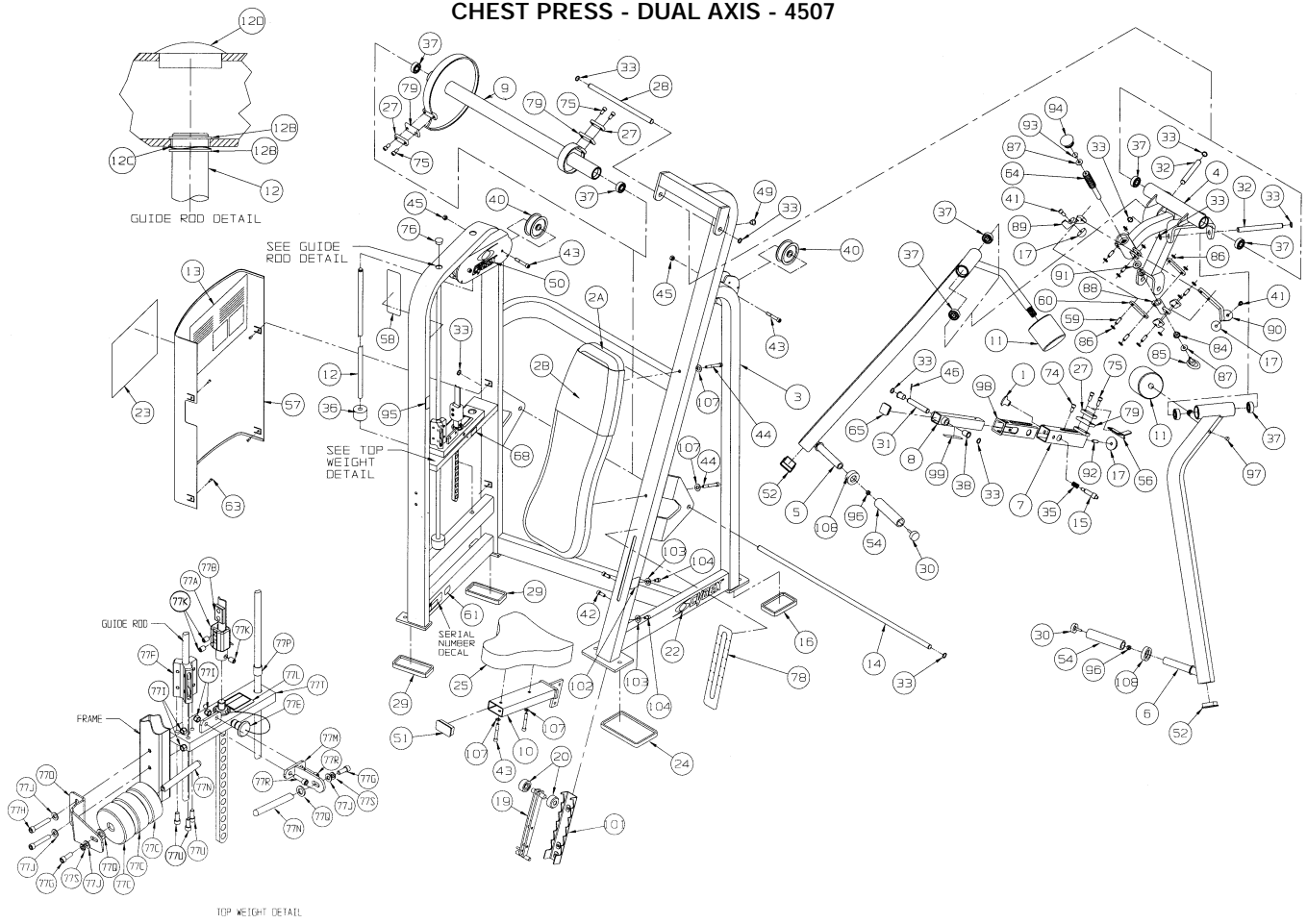

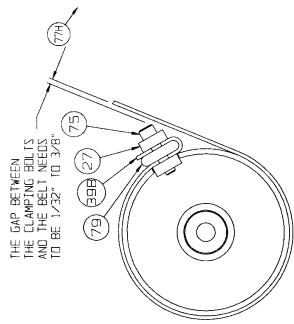

BELT CLAMPING DETAIL

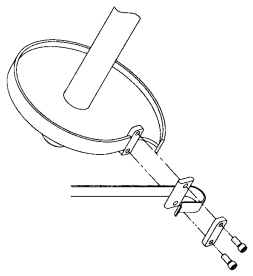

BELT ROUTING DETAIL

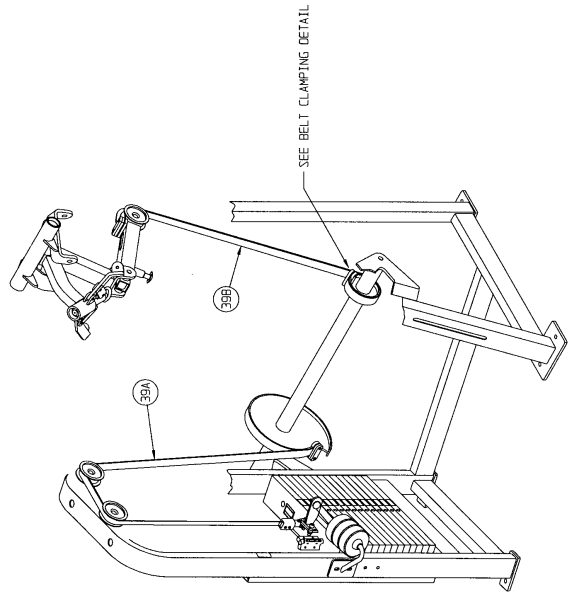
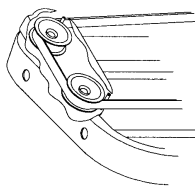

INCLINE PRESS - SINGLE AXIS

PRODUCT NO. 4511

PARTS LIST

Note: Item D - Weight Stack Belt = 85.0" Long
Item D - Rear Belt = 41.0" Long

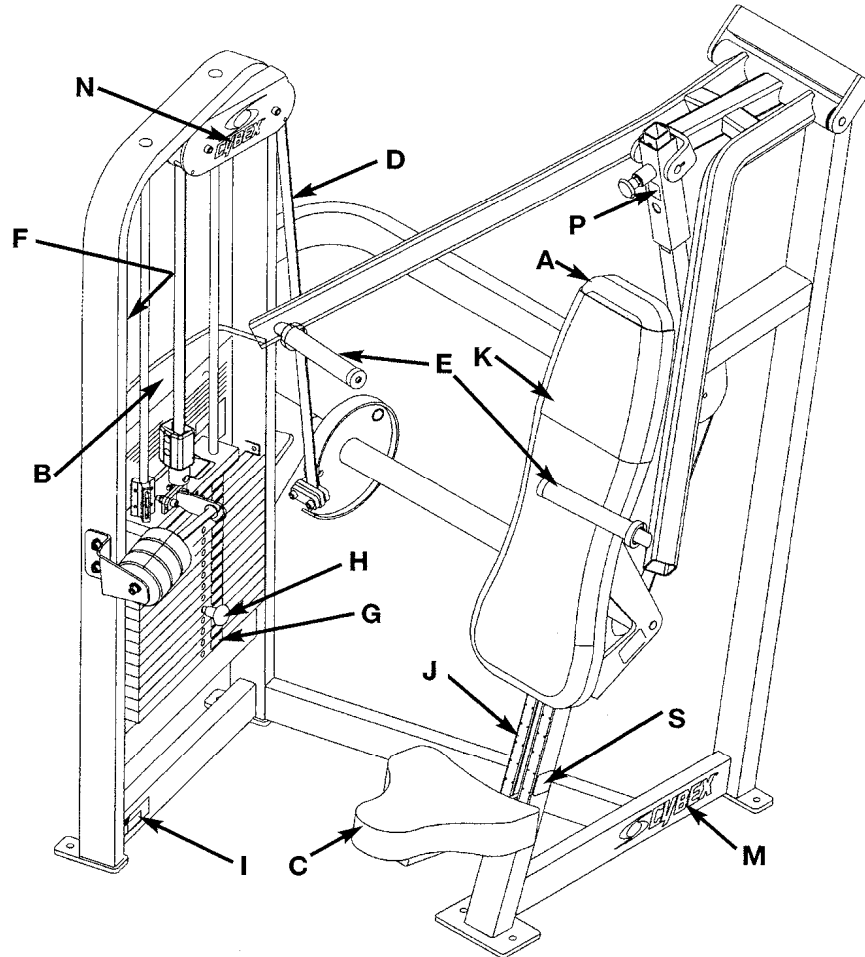

See exploded-view diagram for items:
L (#56), O (#60 K), Q (#65) and R (#67).

DESCRIPTION	PART NO.	DESCRIPTION	PART NO.
A. Back Cushion w/Wear Cover	4800-009	L. Cybex Decal Blk/Plm	3900-439
B. Placard Decal	4511-598	L. Cybex Decal Wht/Wht...	3900-440
C. Seat Cushion.....	4800-026	M. Cybex Decal Blk/Plm.....	3900-390
D. Belt	GB000202	M. Cybex Decal Wht/Wht...	3900-415
E. Grip 7.75 Long	4605-516	N. Cybex Decal Blk/Plm	3900-423
F. Warning Decal.....	4605-381	N. Cybex Decal Wht/Wht...	3900-424
G. Weight Plate Decal	4605-388	O. Caution Decal.....	4605-424
H. Weight Selector Pin.....	BH030207	P. Caution Decal.....	4510-321
I. Serial Number Decal		Q. Caution Decal.....	4000Y316
J. Seat Adjustment Decal..	5221-316	R. Adjusting Decal	4511-309
K. Wear Cover	4800-092	S. Caution Decal	4520-362

4511 - Incline Press - Single Axis

ITEM	QTY	PART NO.	DESCRIPTION
1	1	11040-440	Cybex Knob
2	1	4505-207	Seat
3	1	4505-327	Pivot Shaft 35.72
4	1	4505-329	Detent Pin
5	1	4505-432	Guard
6	1	4511-201	Frame
7	1	4511-203	Adjusting Tube (inner)
8	1	4510-205	Adjusting Tube (outer)
9	1	4605-512	Plastic Insert 7.94
10			Not Used
11	1	4511-200	Pivot
12	1	4511-598	Placard Decal
13	1	4520-212	Seat Roller
14	2	4520-331	Roller
15			Removed
16	1	PR070002	Foot Pad 4.00 x 7.00
17	1	5221-316	Seat Adjustment Decal
18	1	4511-202	Cam
19	3	4605-300	Belt Clamp
20	1	4605-334	Pivot Shaft 13.06
21	3	PR070003	Foot Pad 4.00 x 5.25
22	2	11090-374	Plug .250-20
23	1	4605-373	Pivot Shaft 4.06
24	1	4605-381	Warning Decal
25			Not Used
26			Not Used
27	1	4605-388	Weight Plate Decal 10-290
28	3	4605-394	Belt Clamp
29	1	4800-026	Seat Cushion
30	1	4701-302	VR2 Weight Stack Instr. (not shown)
31	6	BR030210	Retaining Ring (17 mm)
32	1	BS070201	Com Spring .56 x .66 x 1.50 L
33			Removed
34	4	FB030232	Radial Bearing 17 mm ID (Ext Race)
35	2	FB130211	Flange Bearing 17 mm x 19 mm x 12 mm
36 A	85.0"	GB000202	Weight Stack Belt .95 Wide
36 B	41.0"	GB000202	Rear Belt .95 Wide
37	3	GB000209	Pulley Assembly 3.50
38	2	HC702817	SHCS .375-16 x 1.00
39	6	HC702822	SHCS .375-16 x 1.50
40	7	HC702830	SHCS .375-16 x 2.50
41	3	HN704901	Locknut .375-16 Nylon
42	1	HP266717	Spiral Pin .125 x 1.00
43			Removed
44			Removed
45	4	HT102214	Tap Screw #10-12 x .625 A (Phil)
46			Not Used
47	4	HN784000	Hex Nut .500-13
48	1	PP090202	Plastic Insert 1.50 x 3.00 11 G
49	1	PP090206	Plastic Insert
50	2	PP090210	Plastic Insert 2.00 sq x 10-14 G
51	1	PP090211	Plastic Insert 1.50 sq x 10-14 G
52	2	4605-516	Grip 7.75 L
53	1	4505-331	Bumper 1.50 Dia
54			Not Used

ITEM	QTY	PART NO.	DESCRIPTION
55 A	1	4800-009	Back Cushion w/Wear Cover
55 B	1	4800-092	Wear Cover
56			Removed 3/03
56	1	3900-439	Cybex Decal 11.37 Vert. Blk/Plm
56	1	3900-440	Cybex Decal 11.37 Vert. Wht/Wht
57			Removed 3/03
57	1	3900-390	Cybex Decal 1.57 Horiz. Blk/Plm
57	1	3900-415	Cybex Decal 1.57 Horiz. Wht/Wht
58	1	3900-423	Cybex Decal 4.85 Vert. Blk/Plm
58	1	3900-424	Cybex Decal 4.85 Vert. Wht/Wht
58			Removed 3/03
59	1	4701-021	Weight Stack Guide Rod Set
59 A	2	4505-319	Weight Stack Guide Rod
59 B	4	BR030214	Retaining Ring .624
59 C	2	HS407100	Spring Washer .65 x .79 x .062T
59 D	2	PN660200	Plastic Insert 1.00 Dia 11 G
59 E	2	PR060005	Weight Bumper
60	1	4701-031	Sliding Increment Weight Set
60 A	1	11040-216	Belt Clamp
60 B	1	11040-301	Belt Clamp Insert
60 C	3	4605-390	Increment Weight
60 D			Removed 3/03
60 E	1	BH030207	Weight Selector Pin
60 F	1	FB130208	Bearing Sleeve .68 x .81 1.00 L
60 G	2	HC702817	SHCS .375-16 x 1.00
60 H	2	HC702828	SHCS .375-16 x 2.25
60 I	4	HN704901	Nylon Locknut .375-16
60 J	4	HS347600	Washer, SAE .375
60 K	1	HY740000	Set Screw
60 L	1	4605-424	Caution Decal
60 M	1	4700-240	Weight Mount
60 N	2	4700-318	Increment Weight Rod
60 O	1	4700-319	Frame Mount Increment Weight
60 P	1	4701-001	Top Weight Guide
60 Q	2	4700-321	Rubber Washer
60 R	2	JC702820	SHCS .375-16 x 1.25
60 S	2	HS348300	Split Lockwasher .375
60 T	1	4700-238	Top Weight
60 U	3	HC702816	SHCS .375-16 x .875
61	1	51198	Strength Warranty Sheet (not shown)
62	1	HP707017	Stud .375-16 x 1.00
63	2	HF449063	Connector Insert .75 x .25-20
64	1	4510-321	Caution Decal
65	3	4000Y316	Caution Decal
66	2	HC702834	SHCS .375-16 x 3.00
67	1	4511-309	Adjusting Decal
68	1	4520-213	Bracket
69	1	4520-362	Caution Decal
70	2	HS347700	Washer USS .375
71	2	JC702812	SHCS .375-16 x .50
72	14	4000C101	Stack Weight 4 x 18 (not shown)
73	2	11090-374	Handle Grip Ring
74	4	JS347400	Internal Tooth Lockwasher .375
75	2	JC620422	BHSCS .250-20 x 1.50

INCLINE PRESS - SINGLE AXIS - 4511

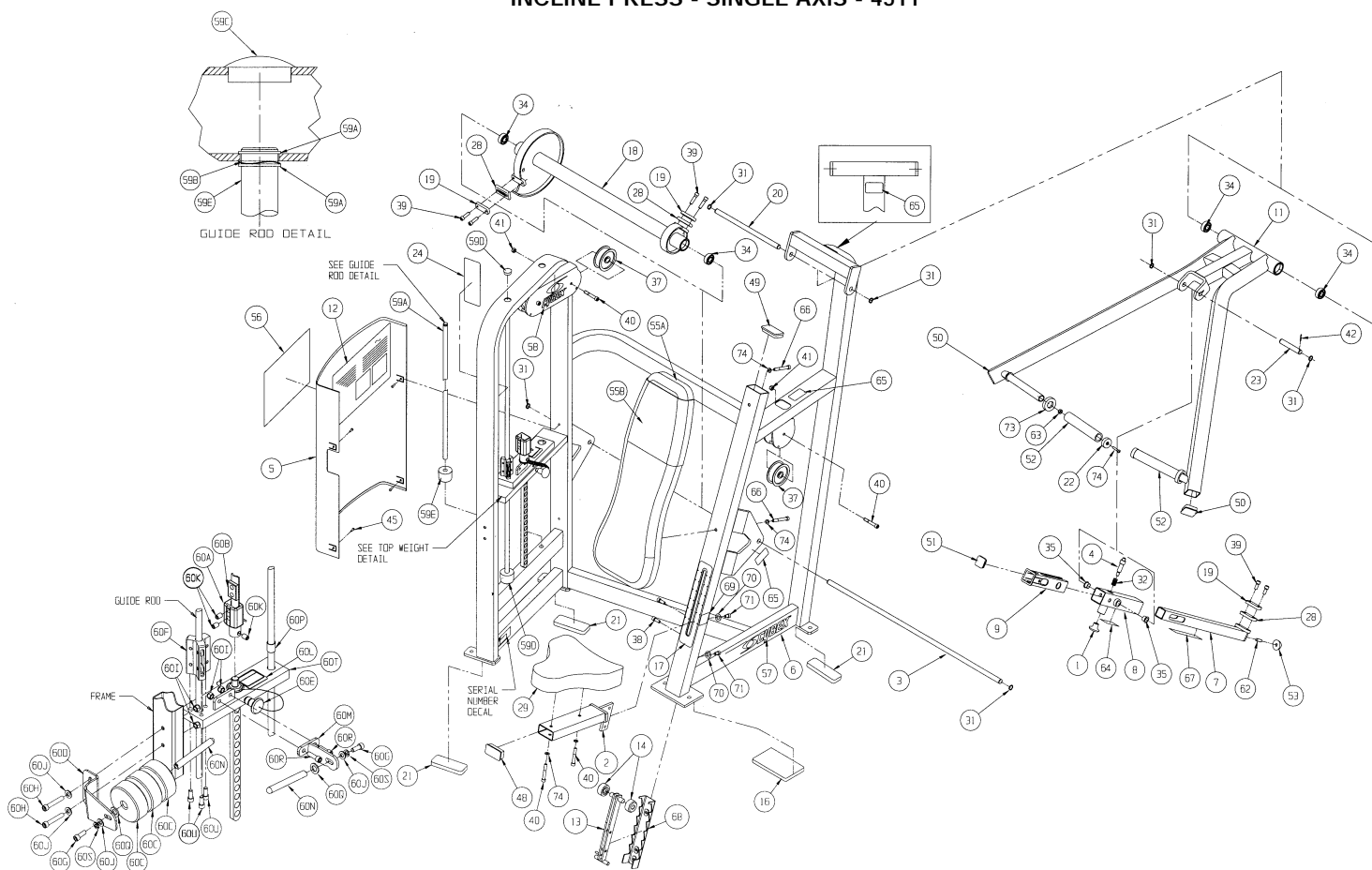

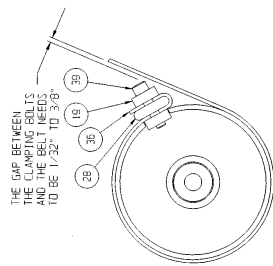

BELT CLAMPING DETAIL

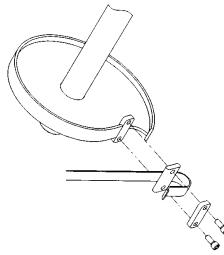

BELT ROUTING DETAIL

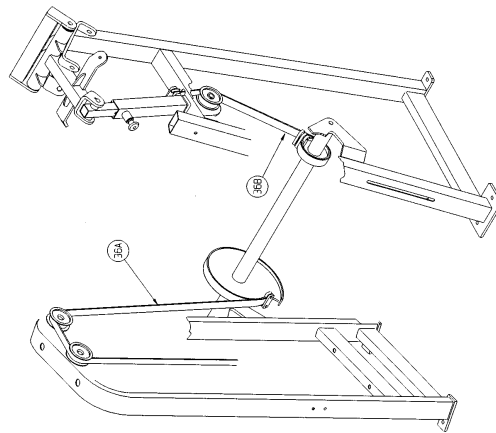
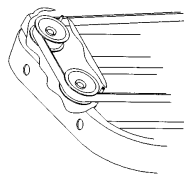

BELT ROUTING DETAIL

INCLINE PRESS - DUAL AXIS

PRODUCT NO. 4512

PARTS LIST

Note: Item D - Weight Stack Belt = 85" Long
Item D - Rear Belt = 41" Long

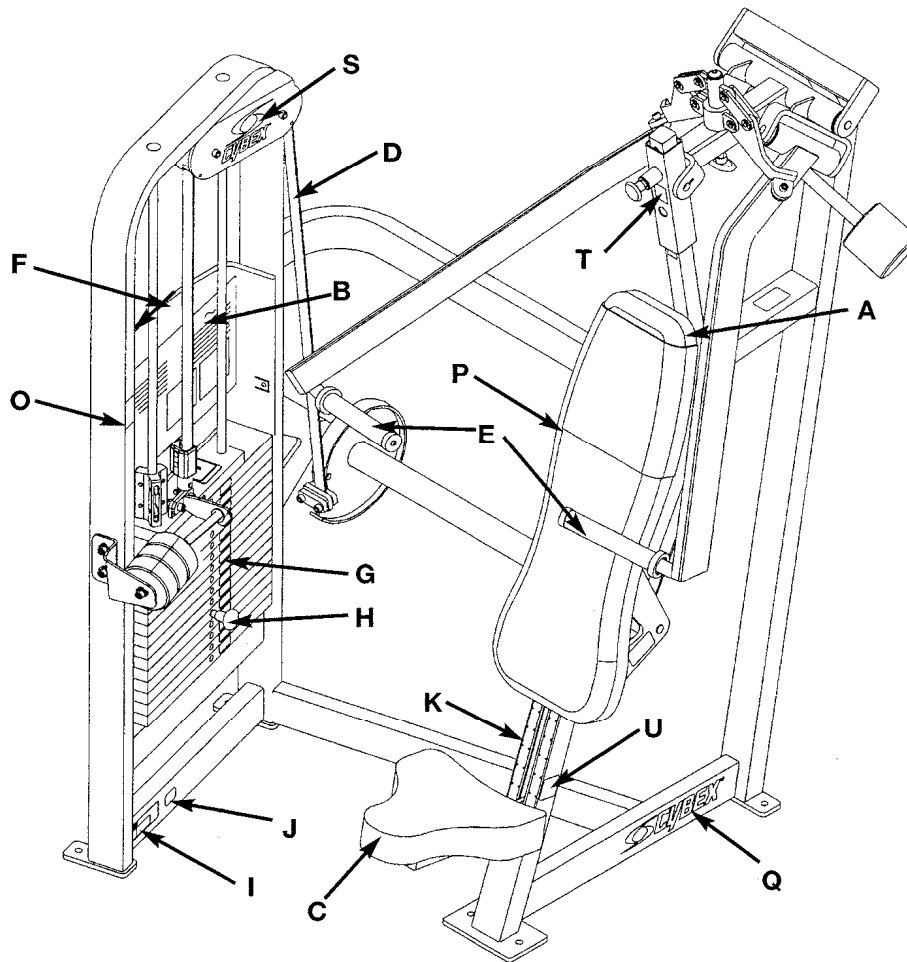

See exploded-view diagram for items:
L (#5), M (#22), N (#41), K, O (#45), R (#81) and U (#86).

DESCRIPTION	PART NO.	DESCRIPTION	PART NO.
A. Back Cushion with/Wear Cover	4800-103	M. Caution Decal	4510-321
B. Placard Decal	4512-598	N. Caution Decal	4605-424
C. Seat Cushion	4800-026	O. Caution Decal	5221-319
D. Belt	GB000202	P. Wear Cover	4800-106
E. Grip 6" Long	4605-500	Q. Cybex Decal Blk/Plm	3900-390
F. Warning Decal	4605-381	Q. Cybex Decal Wht/Wht ..	3900-415
G. Weight Plate Decal	4605-388	R. Cybex Decal Blk/Plm	3900-391
H. Weight Selector Pin	BH030207	R. Cybex Decal Wht/Wht...	3900-419
I. Serial Number Decal		S. Cybex Decal Blk/Plm	3900-423
J. Patent Decal	CM000211	S. Cybex Decal Wht/Wht ..	3900-424
K. Seat Adjustment Decal...	5221-316	T. Adjusting Decal	4511-309
L. Caution Decal	4000Y316	U. Caution Decal	4520-362

4512 - Incline Press - Dual Axis

ITEM	QTY	PART NO.	DESCRIPTION
1	1	PP460012	Knob
2			Removed
3	12	08017	Retaining Ring .375
4	1	11040-440	Cybex Knob
5	3	4000Y316	Caution Decal
6	1	4505-207	Seat
7	2	4505-318	Counterweight
8	1	4505-327	Pivot Shaft 35.72
9	1	4505-329	Detent Pin
10	5	4505-331	Bumper 1.50 Dia
11	1	4505-432	Guard
12	1	51198	Strenght Warranty Sheet (not shown)
13	1	4507-201	Slide
14	6	4507-301	Pin
15	4	4507-302	Link Bar
16	2	4507-310	Flat Washer .647 x 1.25 x .105 T
17	1	4511-201	Frame
18	1	4510-202	Arm (Left Hand)
19	1	4510-203	Arm (Right Hand)
20	1	4511-203	Adjusting Tube (Inner)
21	1	4510-205	Adjusting Tube (Outer)
22	1	4510-321	Caution Decal
23	1	4512-201	Bearing Housing
24	1	4512-203	Stop (Right Hand)
25	1	4512-204	Stop (Left Hand)
26	1	4512-300	Adjustment Screw
27	1	4512-598	Placard Decal
28	1	4520-212	Seat Roller
29	2	4520-331	Roller
30			Removed
31	1	4511-202	Cam
32	3	4605-300	Belt Clamp
33	1	4605-334	Pivot Shaft 13.06
34	1	4605-373	Pivot Shaft 4.06
35	1	4605-381	Warning Decal
36	1	4605-388	Weight Plate Decal 10-290
37	3	4605-394	Belt Clamp
38	1	4605-512	Plastic Insert 7.94
39	2	4605-550	Plug .250-20 large
40	1	4701-021	Weight Stack Guide Rod Set
40 A	2	4505-319	Weight Stack Guide Rod
40 B	4	BR030214	Retaining Ring .625
40 C	2	HS407100	Spring Washer .65 x .79 x .062T
40 D	2	PN660200	Plastic Insert 1.00 Dia 11G
40 E	2	PR060005	Weight Bumper
41	1	4701-031	Sliding Increment Weight Set
41 A	1	11040-216	Belt Clamp
41 B	1	11040-301	Belt Clamp Insert
41 C	3	4605-390	Increment Weight
41 D			Removed 3/03
41 E	1	BH030207	Weight Selector Pin
41 F	1	FB130208	Bearing Sleeve .68 x .81 1.00 L
41 G	4	HC702817	SHCS .375-16 x 1.00
41 H	2	HC702828	SHCS .375-16 x 2.25
41 I	4	HN704901	Nylon Locknut .375-16
41 J	4	HS347600	Washer, SAE .375
41 K	3	HY740000	Set Screw .375-16 x .25 Cup Pt
41 L	1	4605-424	Caution Decal
41 M	1	4700-240	Weight Mount
41 N	2	4700-318	Increment Weight Rod
41 O	1	4700-319	Frame Mount Increment Weight
41 P	2	4701-001	Top Weight Guide
41 Q	2	4700-321	Rubber Washer

ITEM	QTY	PART NO.	DESCRIPTION
41 R	2	JC702820	SHCS .375-16 x 1.25
41 S	2	HS348300	Split Lockwasher .375
41 T	1	4700-238	Top Weight
41 U	2	HC702816	SHCS .375-16 x .875
41	1	4701-302	VR2 Weight Stack Instr (not shown)
43	2	5220-320	Pivot Shaft 7.06
44	1	5221-316	Seat Adjustment Decal
45	1	5221-319	Caution Decal
46	10	BR030210	Retaining Ring 17mm
47	1	BR030217	Retaining Ring .750 Ext
48	1	BS070201	Com Spring .56 x .66 x 1.50 L
49			Removed
50	1		Removed
51	8	FB030232	Radial Brg 17 mm ID Ext Race
52	2	FB130211	Flange Brg 17 mm x 19 mm 12 mm
53	2	FB130212	Flange Brg
54 A	85.0"	GB000202	Weight Stack Belt .95 wide
54 B	41.0"	GB000202	Rear Belt .95 wide
55	3	GP000209	Pulley Assembly 3.50
56	2	HC702815	SHCS .375-16 x .750
57	2	HC702817	SHCS .375-16 x 1.00
58	6	HC702822	SHCS .375-16 x 1.50
59	7	HC702830	SHCS .375-16 x 2.50
60	2	HF449063	Connector Insert .75 x .25-20
61	1	HN704000	Hex Nut .375-16
62	3	HN704901	Nylon Locknut .375-16
63	1	HN784000	Hex Nut .500-13
64	1	HP266717	Spiral Pin .125 x 1.00
65			Removed
66	1	HP707017	Stud .375-16 x 1.00
67	1	HS387700	Washer .375 SAE
68	4	HT102214	Tap Screw #10-12 x .625 A (Phil)
69	1	JC780417	BHSCS .500-13 x 1.00
70	1	PP090202	Plastic Insert 1.5 x 3.0 11 G
71	1	PP090206	Plastic Insert
72	2	PP090210	Plastic Insert 2.00 Sq x 10-14 G
73	1	PP090211	Plastic Insert 1.50 Sq x 10-14 G
74	1	4800-026	Seat Cushion
75	1	PR070002	Foot Pad 4.00 x 7.00
76	3	PR070003	Foot Pad 2.00 x 5.25
77	2	4605-500	Grip 6" Long
78 A	1	4800-009	Back Cushion w/Wear Cover
78 B	1	4800-092	Wear Cover
79			Not Used
80			Removed 3/03
80	1	3900-390	Cybex Decal 1.57 Horiz. Blk/Plm
80	1	3900-415	Cybex Decal 1.57 Horiz. Wht/Wht
81			Removed 3/03
81	1	3900-391	Cybex Decal 11.37 Horiz. Blk/Plm
81	1	3900-419	Cybex Decal 11.37 Vert. Wht/Wht
82	1	3900-423	Cybex Decal 4.85 Vert. Blk/Plm
82	1	3900-424	Cybex Decal 4.85 Vert. Wht/Wht
82			Removed 3/03
83	2	HC702834	SHCS .375-16 x 3.00
84	1	4511-309	Adjusting Decal
85	1	4520-213	Bracket
86	1	4520-362	Caution Decal
87	2	HS347700	Washer USS .375
88	2	JC702812	SHCS .375-16 x .50
89	14	4000C101	Stack Weight 4 x 18
90	2	11090-376	Handle Grip Ring
90	3	JS347400	Lockwasher Int Tooth .375

INCLINE PRESS - DUAL AXIS - 4512

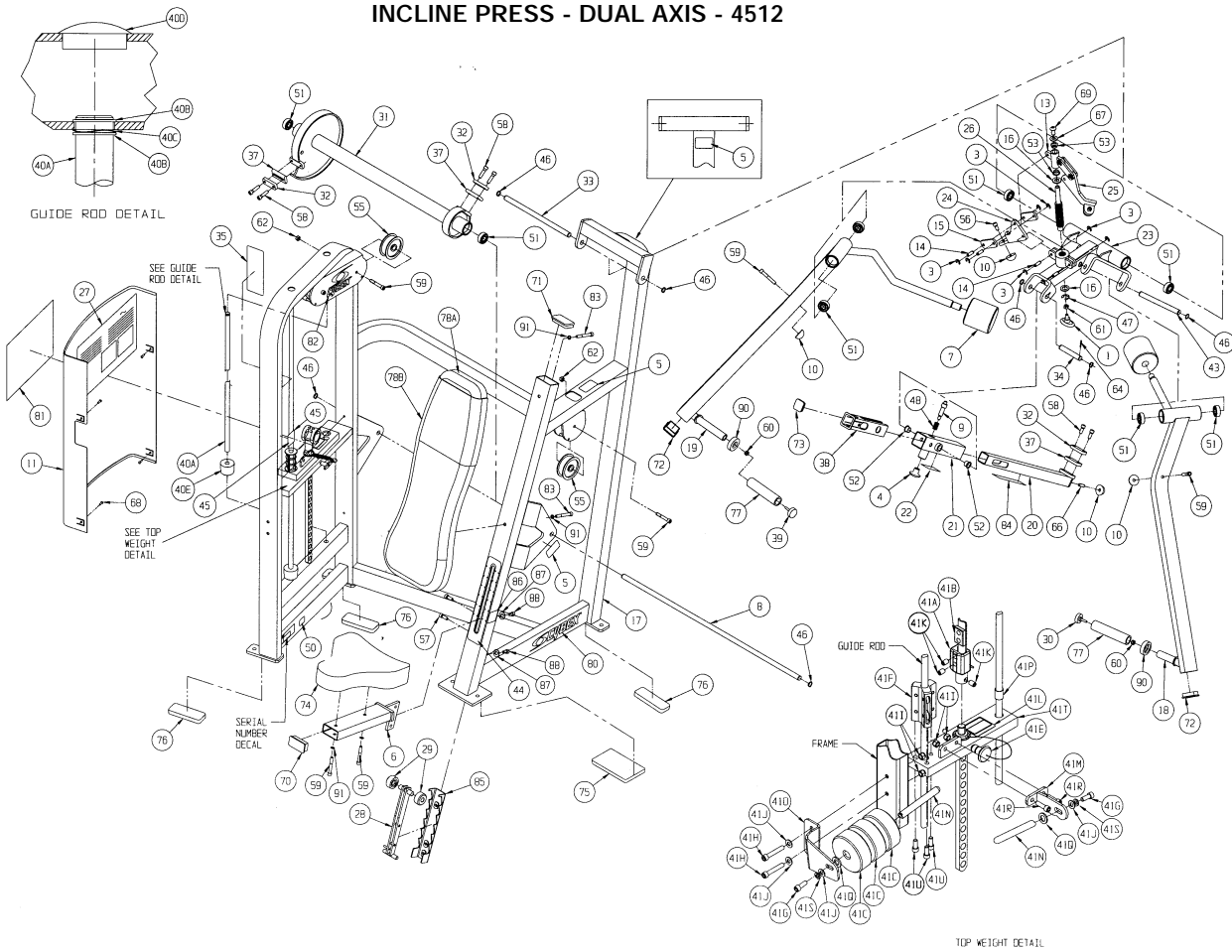

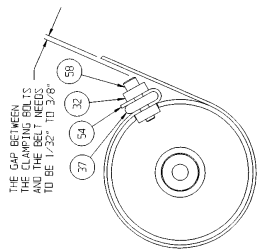

BELT CLAMPING DETAIL

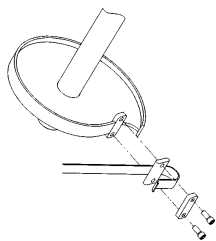

BELT ROUTING DETAIL

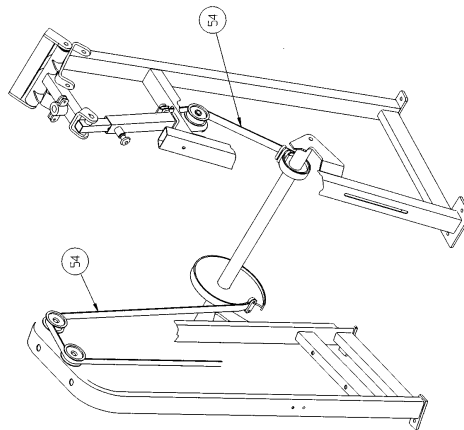
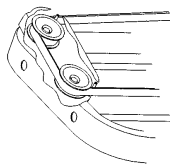

BELT ROUTING DETAIL

PULLDOWN - DUAL AXIS

PRODUCT NO. 4515

PARTS LIST

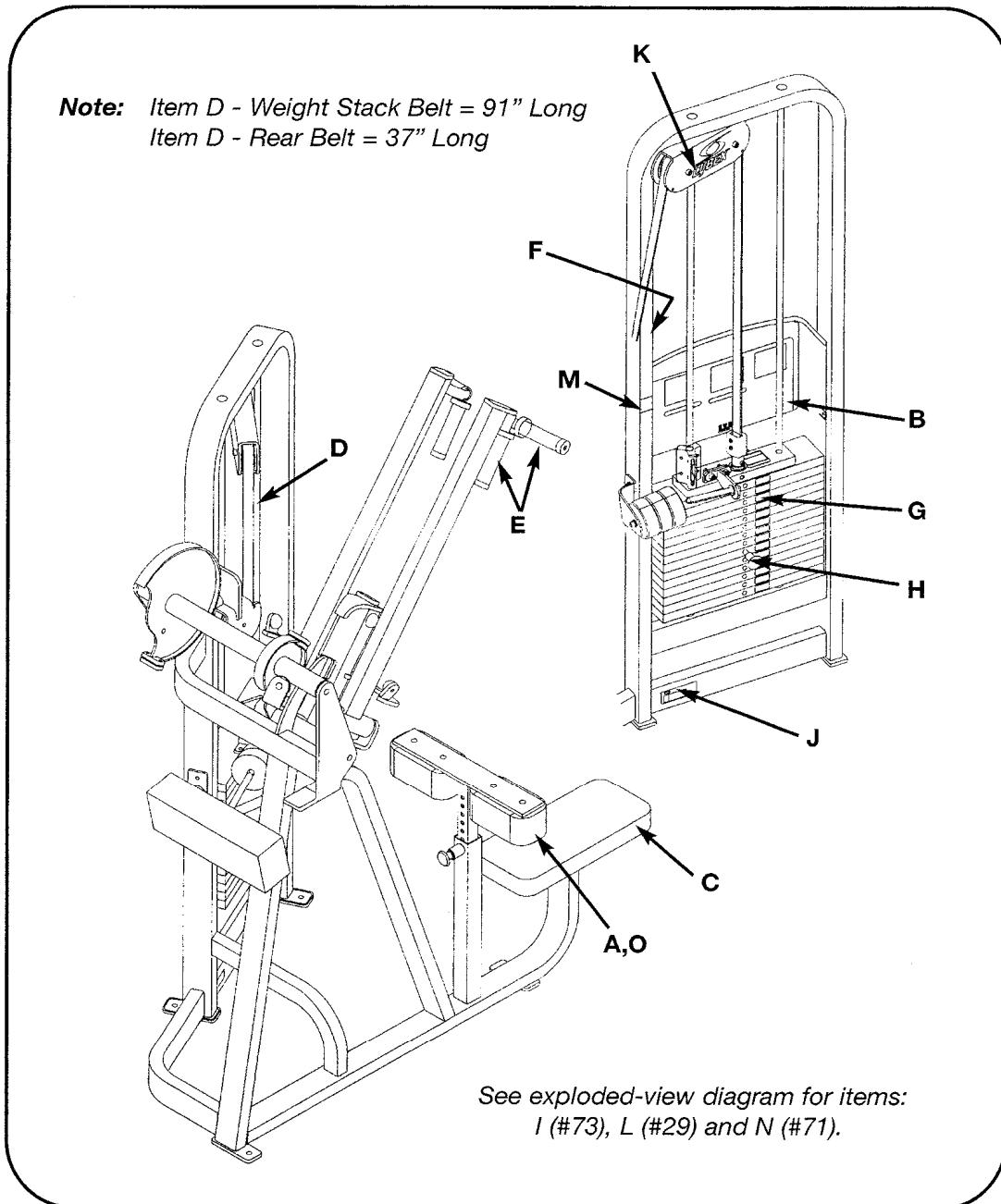

DESCRIPTION	PART NO.	DESCRIPTION	PART NO.
A. Thigh Cushion w/Wear Cover	4800-071	I. Adjusting Knee Decal....	4810-310
B. Placard Decal.....	4515-331	J. Serial Number Decal	
C. Seat Cushion.....	4800-024	K. Cybex Decal Blk/Plm	3900-423
D. Belt.....	GB000202	K. Cybex Decal Wht/Wht...	3900-424
E. Grip 5" Long	4605-501	L. Cybex Decal Blk/Plm	3900-391
F. Warning Decal.....	4605-381	L. Cybex Decal Wht/Wht...	3900-419
G. Weight Plate Decal.....	4605-388	M. Caution Decal	5221-319
H. Weight Selector Pin.....	BH030207	N. Caution Decal	4605-424
		O. Wear Cover	4800-101

4515 - Pulldown - Dual Axis

ITEM	QTY	PART NO.	DESCRIPTION
1	1	11040-440	Cybex Knob
2	1	ZC000001	Counterweight
3			Removed 8/98
4	1	4605-322	Detent Pin
5	4	4505-331	Bumper 1.50 Dia
6	1	4505-432	Guard
7	2	4800-071	Thigh Cushion w/Wear Cover
8	1	4515-200	Frame
9	1	4515-201	Cam
10	1	4515-202	Handle (Left Hand)
11	1	4515-203	Handle (Right Hand)
12	1	4515-207	Seat Post
13	2	4515-205	Arm
14	1	4515-206	Bearing Housing
15	1	4515-331	Placard Decal
16	1	4515-327	Pivot Shaft 26.06
17	1	4701-021	Guide Rod Set - 51"
17 A	2	4505-319	Weight Rod .625 Dia x 51"
17 B	4	BR030214	Retaining Ring .625
17 C	2	HS407100	Spring Washer .65 x .79 x .062T
17 D	2	PN660200	Plastic Insert 1.00 Dia 11G
17 E	2	PR060005	Weight Bumper
18	1	4800-024	Seat Cushion
19	1	4605-512	Plastic Insert 7.94
20			Removed 8/98
21	2	4535-328	Pivot Pin (Short)
22			Removed
23	3	4605-300	Belt Clamp
24	1	4605-334	Pivot Shaft 13.06
25	4	PR070003	Foot Pad 2.00 x 5.25
26	2	11090-374	End Cap
27	1	4605-381	Warning Decal
28	1	3900-423	Cybex Decal 4.85 Vert. Blk/Plm
28	1	3900-424	Cybex Decal 4.85 Vert. Wht/Wht
28			Removed 3/03
29			Removed 3/03
29	1	3900-391	Cybex Decal 11.37 Vert. Blk/Plm
29	1	3900-419	Cybex Decal 11.37 Vert. Wht/Wht
30	2	5220-320	Pivot Shaft 7.06
31	8	BR030210	Retaining Ring 17 mm
32			Not Used
33	1	BS070201	Com. Spring .56 ID x .66 OD x 1.50 L
34			Not Used
35			Removed 5/99
36	8	FB030232	Radial Bearing 17 mm ID (Ext Race)
37	4	FB130205	Flange Bearing .62 x .75 x .38 L
38 A	91"	GB000202	Weight Stack Belt .95" Wide
38 B	37"	GB000202	Input Arm Belt .95" Wide
39	3	GP000209	Pulley Assembly 3.50
40	4	HC702815	SHCS .375-16 x .750
41			Removed 8/98
42	6	HC702817	SHCS .375-16 x 1.00
43	3	HC702830	SHCS .375-16 x 2.50
44	5	HN704901	Nylon Locknut .375-16
45	1	HP707038	Stud .375-16 x 3.50

ITEM	QTY	PART NO.	DESCRIPTION
46			Not Used
47	4	HT102214	Tap Screw #10-12 x .625 A (Phil)
48	4	JC702820	SHCS .375-16 x 1.25
49			Removed 8/98
50			Not Used
51	4	4605-501	Grip 5" long
52	1	PU060203	Bumper
53			Not Used
54			Not Used
55			Not Used
56			Not Used
57	3	4605-394	Belt Clamp
58	1	4701-030	Sliding Increment Weight Set
58 A	1	11040-216	Belt Clamp
58 B	1	11040-301	Belt Clamp Insert
58 C	3	4605-390	Increment Weight
58 D	1	BH030207	Weight Selector Pin
58 E	1	FB130208	Bearing Sleeve .68 x .81 1.00 L
58 F	2	HC702817	SHCS .375-16 x 1.00
58 G	2	HC702828	SHCS .375-16 x 2.25
58 H	4	HN704901	Nylon Locknut .375-16
58 I	4	HS347600	Washer, SAE .375
58 J	1	HY740000	Set Screw
58 K	1	4605-424	Caution Decal
58 L	1	4700-240	Weight Mount
58 M	2	4700-318	Increment Weight Rod
58 N	1	4700-319	Frame Mount Increment Weight
58 O	2	4701-001	Top Weight Guide
58 P	2	4700-321	Rubber Washer
58 Q	2	JC702820	SHCS .375-16 x 1.25
58 R	2	HS348300	Split Lockwasher .375
58 S	1	4700-239	Top Weight
58 T	3	HC702816	SHCS .375-16 x .875
59			Not Used
60			Not Used
61	1	BH030206	Weight Selector Pin
62			Not Used
63			Not Used
64			Not Used
65	6	HC702822	SHCS .375-16 x 1.50
66			Removed
67	1	4701-302	VR2 Weight Stack Instr. (not shown)
68	1	51198	Strength Warranty Sheet (not shown)
69	4	HF449063	Tube Insert
70	1	5221-319	Caution Decal
71			Not Used
72	2	4800-101	Wear Cover
73	1	4810-310	Adjusting Knee Decal
74	14	4000C101	Stack Weight 4 x 18 (not shown)
75	4	JS347400	Lockwasher Int Tooth
76	1	4605-388	Weight Plate Decal (not shown)
77	2	11090-376	Handle Grip Ring
78	4	JC620422	BHSCS .250-20 x 1.50
79	6	JS347400	Internal Lockwasher .375

PULLDOWN - DUAL AXIS - 4515

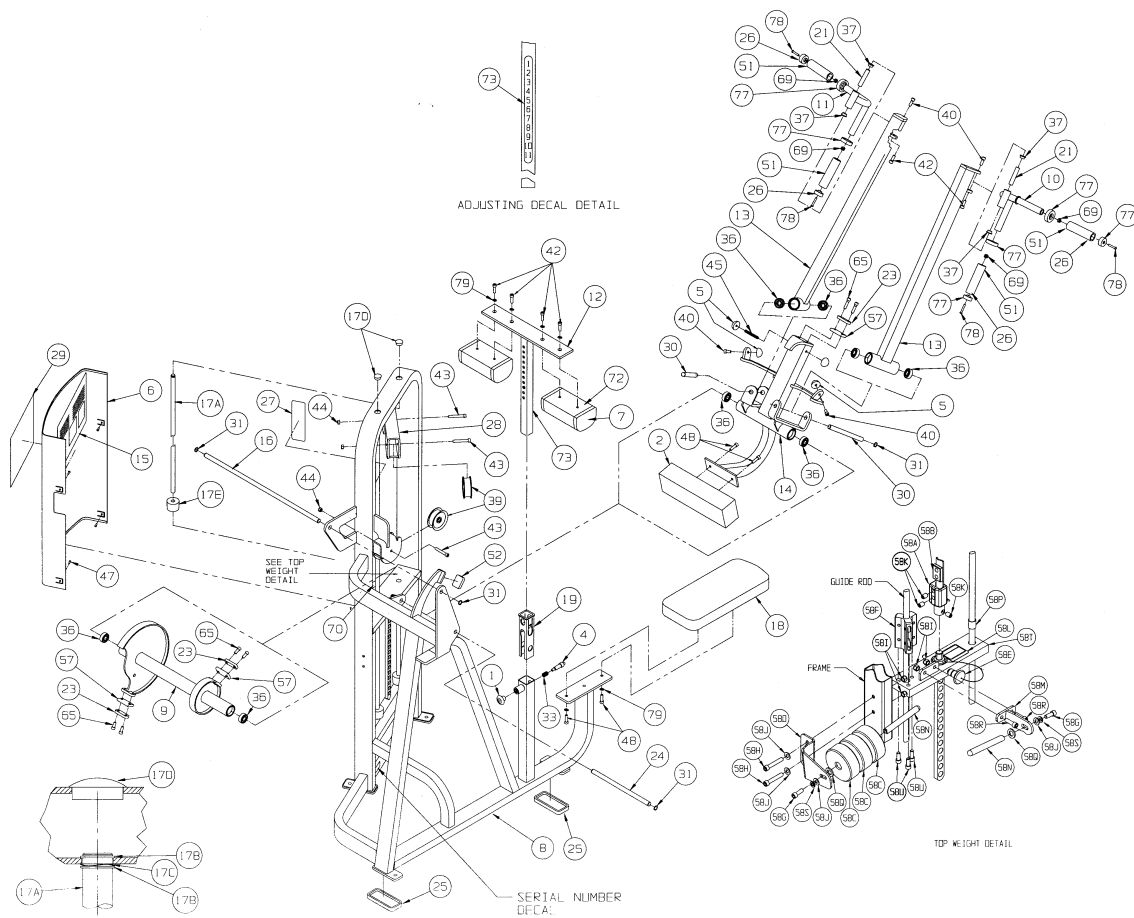

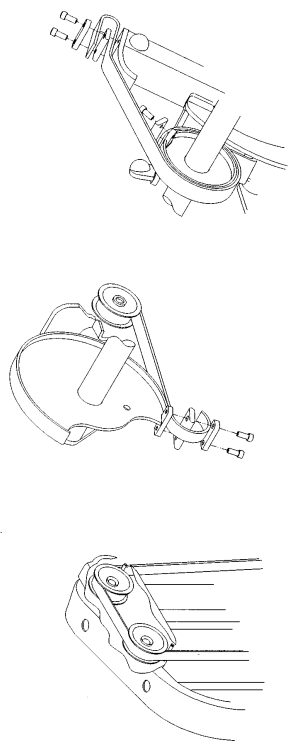

BELT ROUTING DETAIL

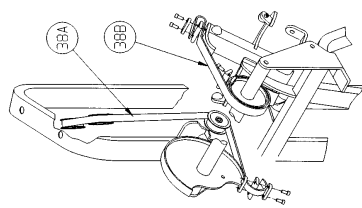

BELT ROUTING DETAIL

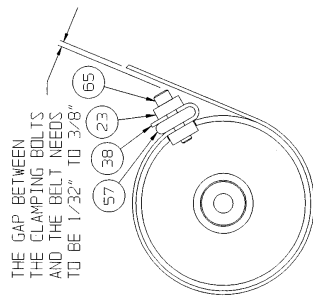

BELT CLAMPING DETAIL

THE GAP BETWEEN THE CLAMPING BOLTS AND THE BELT NEEDS TO BE 1/32" TO 3/8"

BELT ROUTING DETAIL

LAT PULLDOWN - SINGLE AXIS

PRODUCT NO. 4516

PARTS LIST

Note: Item D - Weight Stack Belt = 91" Long
Item D - Rear Belt = 37" Long

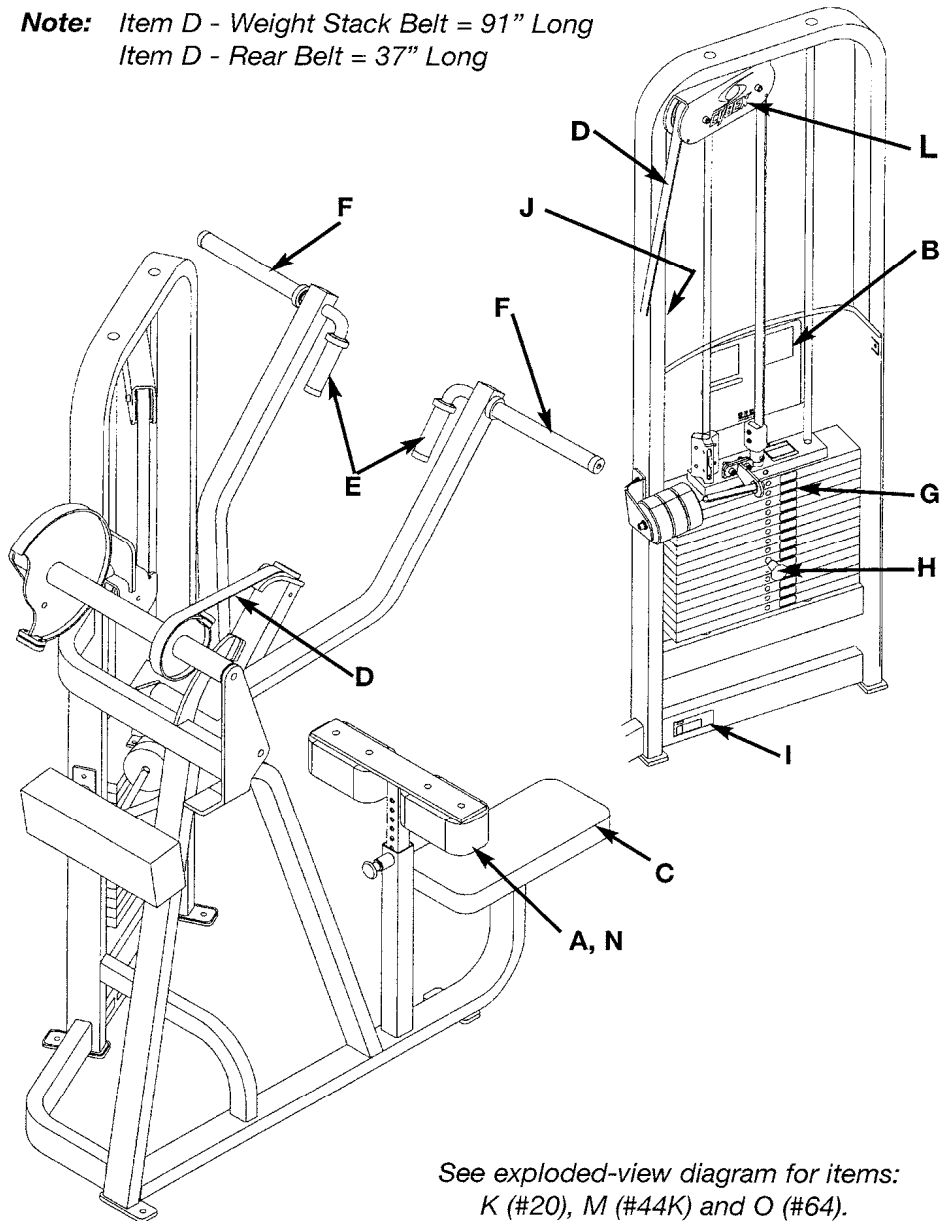

See exploded-view diagram for items:
K (#20), M (#44K) and O (#64).

DESCRIPTION	PART NO.	DESCRIPTION	PART NO.
A. Thigh Cushion w/Wear Cover.....	4800-071	I. Serial Number Decal	
B. Placard Decal.....	4516-598	J. Warning Decal.....	4605-381
C. Seat Cushion.....	4800-024	K. Cybex Decal Blk/Plm	3900-391
D. Belt.....	GB000202	K. Cybex Decal Wht/Wht ..	3900-419
E. Grip 4.5" Long.....	4605-514	L. Cybex Decal Blk/Plm	3900-423
F. Grip 11.5" Long.....	4605-517	L. Cybex Decal Wht/Wht ..	3900-424
G. Weight Plate Decal.....	4605-388	M. Caution Decal.....	4605-424
H. Weight Selector Pin.....	BH030207	N. Wear Cove (Item A)	4800-101
		O. Adjusting Knee Decal....	4810-310

4516 - Lat Pulldown - Single Axis

ITEM	QTY	PART NO.	DESCRIPTION	ITEM	QTY	PART NO.	DESCRIPTION
1	1	11040-440	Cybex Knob	44 B	1	11040-301	Belt Clamp Insert
2	1	ZC000001	Counterweight	44 C	3	4605-390	Increment Weight
3			Removed 8/98	44 D			Removed 3/03
4	1	4505-432	Guard	44 E	1	BH030207	Weight Selector Pin
5	1	4515-200	Frame	44 F	1	FB130208	Bearing Sleeve .68 x .81 1.00 L
6	1	4515-201	Cam	44 G	2	HC702817	SHCS .375-16 x 1.00
7	1	4515-207	Seat Post	44 H	2	HC702828	SHCS .375-16 x 2.25
8	1	4515-327	Pivot Shaft 26.06	44 I	4	HN704901	Nylon Locknut .375-16
9	1	4516-201	Arms	44 J	4	HS347600	Washer, SAE .375
10	1	4516-598	Placard Decal	44 K	1	HY740000	Set Screw
12	1	4605-512	Plastic Insert 7.94	44 L	1	4605-424	Caution Decal
13	3	4605-300	Belt Clamp	44 M	1	4700-240	Weight Mount
14	1	4605-322	Detent Pin	44 N	2	4700-318	Increment Weight Rod
15	1	4605-334	Pivot Shaft 13.06	44 O	1	4700-319	Frame Mount Increment Weight
16	4	PR070003	Foot Pad 2.00 x 5.25	44 P	2	4701-001	Top Weight Guide
17	4	11090-374	End Cap	44 Q	2	4700-321	Rubber Washer
18	1	4605-381	Warning Decal	44 R	2	JC702820	SHCS .375-16 x 1.25
19	1	3900-423	Cybex Decal 4.85 Vert. Blk/Plm	44 S	2	HS348300	Split Lockwasher .375
19	1	3900-424	Cybex Decal 4.85 Vert. Wht/Wht	44 T	1	4700-238	Top Weight
19			Removed 3/03	44 U	3	HC702816	SHCS .375-16 x .875
20			Removed 3/03	45			Removed
20	1	3900-391	Cybex Decal 11.37 Vert. Blk/Plm	46			Not Used
20	1	3900-419	Cybex Decal 11.37 Vert. Wht/Wht	47			Not Used
21	1	4605-388	Weight Plate Decal 10-290	48			Not Used
22	3	4605-394	Belt Clamp	49			Not Used
23	4	BR030210	Retaining Ring .625	50			Not Used
24	1	BS070201	Com Spring .56 x .66 x 1.50 L	51	1	4701-023	Weight Stack Guide Rod Set
25	4	FB030232	Radial Brg 17 mm ID (Ext Race)	51 A	2	4515-328	Weight Stack Guide Rod
26 A	91"	GB000202	Weight Stack Belt .95" Wide	51 B	4	BR030214	Retaining Ring .625
26 B	37"	GB000202	Belt .95" Wide	51 C	2	HS407100	Spring Washer .65 x .79 x .062 T
27	3	GP000209	Pulley Assembly 3.50	51 D	2	PN660200	Plastic Insert 1.00 Dia x 11 G
28	6	HC702822	SHCS .375-16 x 1.50	51 E	2	PR060005	Weight Bumper
29	3	HN704901	Nylon Locknut .375-16	52			Removed
30			Not Used	53			Removed
31	4	HT102214	Tap Screw #10-12 x .625 A (Phil)	54			Removed
32	4	JC702820	SHCS .375-16 x 1.25	55	2	4800-071	Thigh Cushion w/Wear Cover
33			Removed	56	1	4800-024	Seat Cushion
34			Not Used	57	4	HC702817	SHCS .375-16 x 1.00
35 A	2	4605-514	Grip 4.5" long	58			Removed
35 B	2	4605-517	Grip 11.5" long	59			Removed
36	1	PU060203	Bumper	60	1	4701-302	VR2 Weight Stack Instr. (not shown)
37	3	HC702830	SHCS .375-16 x 2.50	61	1	51198	Strength Warranty Sheet (not shown)
38	2	PP090210	Plastic Insert 2.00 Sq x 10-14 G	62	4	HF449063	Tube Insert
39	2	PP660006	Snap-In Plug	63	1	4800-101	Wear Cover
40			Not Used	64	1	4810-310	Adjusting Knee Decal
41			Not Used	65	14	4000C101	Stack Weight 4 x 18 (not shown)
42			Not Used	66	4	11090-376	Handle Grip Ring
43			Not Used	67	6	JS347400	Internal Tooth Lockwasher
44	1	4701-031	Sliding Increment Weight Set	68	4	JC620422	BHSCS ...250-20 x 1.50
44 A	1	11040-216	Belt Clamp				

LAT PULLDOWN - SINGLE AXIS - 4516

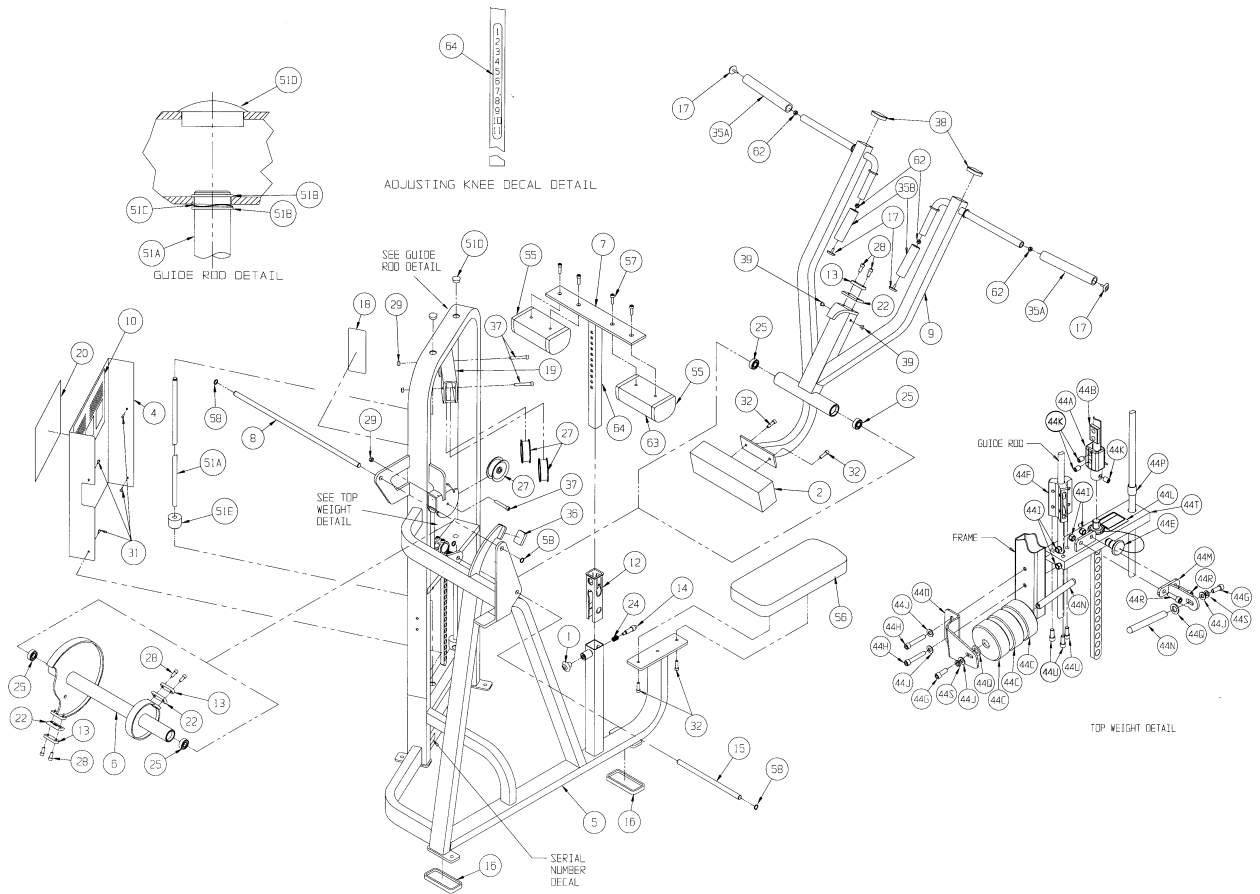

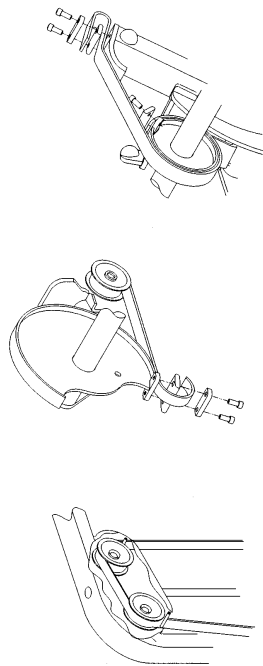

BELT ROUTING DETAIL

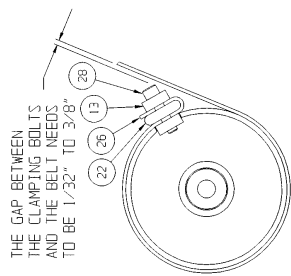

THE GAP BETWEEN THE CLAMPING BOLTS AND THE BELT NEEDS TO BE 1/32" TO 3/8"

BELT CLAMPING DETAIL

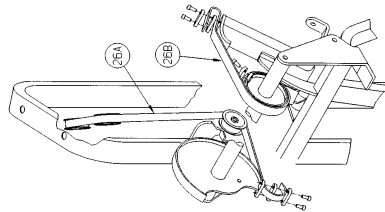

BELT ROUTING DETAIL

BELT ROUTING DETAIL

ROW / REAR DELT - DUAL AXIS

PRODUCT NO. 4520

PARTS LIST

Note: Item D - Weight Stack Belt = 57.5" Long
Item D - Input Arm Belt = 32" Long

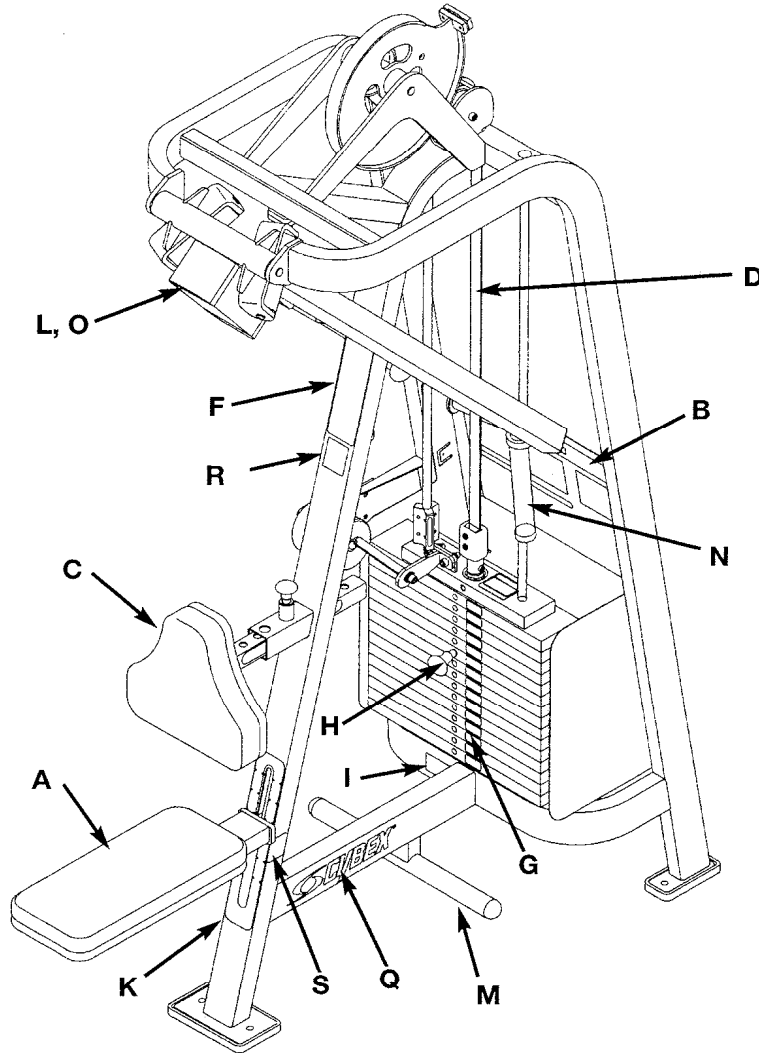

See exploded-view diagram for items:
E (#43 B), J (#77), and P (#67).

DESCRIPTION	PART NO.	DESCRIPTION	PART NO.
A. Seat Cushion	4800-024	L. Cushion w/Wear Cover..	4800-071
B. Placard Decal	4520-318	M. Rubber Grip	02022
C. Chest Cushion	4800-026	N. Grip.....	4605-502
D. Belt	GB000202	O. Wear Cover (Item L)	4800-101
E. Grip.....	4605-501	P. Cybex Decal Blk/Plm	3900-391
F. Warning Decal	4605-381	P. Cybex Decal Wht/Wht ..	3900-419
G. Weight Plate Decal.....	4605-388	Q. Cybex Decal Blk/Blk	3900-390
H. Weight Selector Pin.....	BH030207	Q. Cybex Decal Wht/Wht ..	3900-415
I. Serial Number Decal		R. Caution Decal	5221-319
J. Adjusting Decal	4520-357	S. Caution Decal.....	4520-362
K. Seat Adjustment Decal .	5221-316	T. Caution Decal.....	4605-424

4520 - Row / Rear Delt - Dual Axis

ITEM	QTY	PART NO.	DESCRIPTION	ITEM	QTY	PART NO.	DESCRIPTION
1	2	08001	Plug 1.50	53			Not Used
2	1	11040-440	Cybex Knob	54			Not Used
3	2	4505-331	Bumper 1.50 Dia	55	1	4605-388	Weight Plate Decal 10-290
4	1	4800-024	Seat Cushion	56			Not Used
5	1	4520-208	Frame	57	1	4701-034	Sliding Increment Weight Set
6	1	4520-209	Cam	57 A	1	11040-216	Belt Clamp
7	1	4520-210	Pivot	57 B	1	11040-301	Belt Clamp Insert
8	1	4520-211	Cushion Tube	57 C	3	4605-390	Increment Weight
9	1	4520-204	Seat Tube	57 D			Removed 3/03
10	1	4520-212	Seat Roller	57 E	1	BH030207	Weight Selector Pin
11	1	4520-206	Arm (Right Hand)	57 F	1	FB130208	Bearing Sleeve .68 x .81 1.00 L
12	1	4520-207	Arm (Left Hand)	57 G	2	HC702817	SHCS .375-16 x 1.00
13	1	4701-022	Weight Stack Guide Rod Set	57 H	2	HC702828	SHCS .375-16 x 2.25
13 A	2	4520-304	Weight Stack Guide Rod	57 I	4	HN704901	Nylon Locknut .375-16
13 B	4	BR030214	Retaining Ring .625	57 J	4	HS347600	Washer, SAE .375
13 C	2	HS407100	Spring Washer .65 x .79 x .062 T	57 K	1	HY740000	Set Screw
13 D	2	PN660200	Plastic Insert 1.00 Dia x 11 G	57 L	1	4605-424	Caution Decal
13 E	2	PR060005	Weight Bumper	57 M	1	4700-240	Weight Mount
14	1	4520-318	Placard Decal	57 N	2	4700-318	Increment Weight Rod
15	2	4520-331	Roller	57 O	1	4700-319	Frame Mount Increment Weight
16			Removed	57 P	2	4701-001	Top Weight Guide
17	1	PR070002	Foot Pad 4.00 x 7.00	57 Q	2	4700-321	Rubber Washer
18	1	4800-026	Chest Cushion	57 R	2	JC702820	SHCS .375-16 x 1.25
19			Removed	57 S	2	HS348300	Split Lockwasher .375
20	3	4605-300	Belt Clamp	57 T	1	4700-238	Top Weight
21	1	4605-322	Detent Pin	57 U	3	HC702816	SHCS .375-16 x .875
22	1	4605-334	Pivot Shaft 13.06	58			Not Used
23	2	PR070003	Foot Pad 2.00 x 5.25	59			Not Used
24	4	11090-374	End Cap	60			Not Used
25	3	5220-320	Pivot Shaft 7.06	61	2	HS407100	Spring Washer .65 x .79 x .06 T
26	8	BR030210	Retaining Ring 17 mm	62	1	HY701408	Set Screw .375-16 Cup Pt.
27			Not Used	63	2	PN660200	Plastic Insert 1.00 Dia x 11 G
28	1	BS070201	Com Spring .56 x .66 x 1.50 L	64	2	01193	Finned Fastener
29	2	PR060005	Weight Bumper	65	1	5221-316	Seat Adjustment Decal
30	8	FB030232	Radial Brg 17 mm ID (Ext Race)	66	1	4605-381	Warning Decal
31 A	57.5"	GB000202	Weight Stack Belt .95" Wide	67			Removed 3/03
31 B	32"	GB000202	Input Arm Belt .95" Wide	67	1	3900-391	Cybex Decal 11.37 Vert. Blk/Wht
32	1	GP000209	Pulley Assembly 3.50	67	1	3900-419	Cybex Decal 11.37 Vert. Wht/Wht
33			Not Used	68	3	4605-394	Belt Clamp
34	2	HC702817	SHCS .375-16 x 1.00	69			Removed 5/99
35	5	HC702830	SHCS .375-16 x 2.50	70	6	HC702822	SHCS .375-16 x 1.50
36	1	HN704901	Nylon Locknut .375-16	71	*	BR030216	Retaining Ring .875
37			Removed	72	1	4701-302	VR2 Weight Stack Instr. (not shown)
38			Not Used	73	1	51198	Strength Warranty Sheet (not shown)
39	2	JC702820	SHCS .375-16 x 1.25	74	4	HF449063	Tube Insert
40	1	PP090202	Plastic Insert 1.5x3.0x11 G	75	1	5221-319	Caution Decal
41	2	PP090210	Insert 2.00 sq x 10-14 G	76			Removed 3/03
42			Removed	76	2	3900-390	Cybex Decal 1.57 Horiz. Blk/Plm
43 A	2	4605-502	Grip 9" long	76	2	3900-415	Cybex Decal 1.57 Horiz. Wht/Wht
43 B	2	4605-501	Grip 5" long	77	1	4520-357	Adjusting Decal
44	1	PU060203	Bumper	78	1	4800-101	Wear Cover
45	1	4605-512	Plastic Insert 7.94	79	1	4520-213	Bracket
46			Removed 8/98	80	1	4520-362	Caution Decal
47	1	PP090211	Plastic Insert 1.50 sq x 10-14 G	81	2	HS347700	Washer USS .375
48	2	02022	Rubber Grip 7.0"	82	2	JC702812	SHCS .375-16 x .50
49	1	4505-443	Guard	83	14	4000C101	Stack Weight 4 x 18 (not shown)
50	4	HT102214	Tap Screw #10-12 x .625 A (Phil)	84	4	11090-376	Handle Grip Ring
51	1	4800-071	Cushion	85	4	JS347400	Internal Tooth Lockwasher
52	2	HC702834	SHCS .375-16 x 3.00	86	4	JC620422	BHSCS .250-20 x 1.50

ROW / REAR DELT - DUAL AXIS 4520

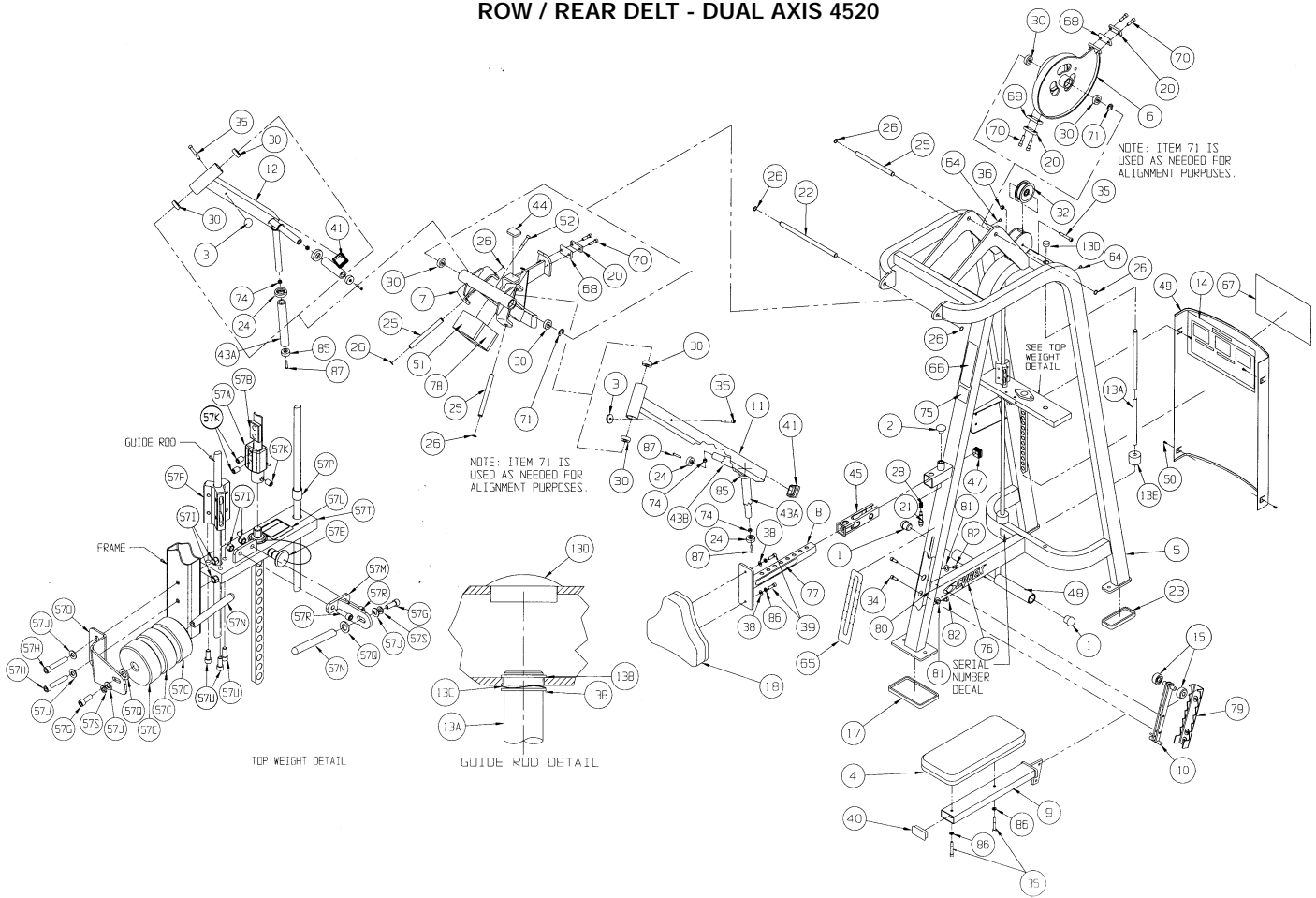

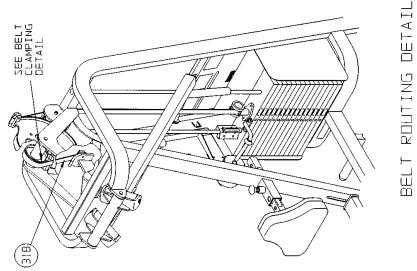
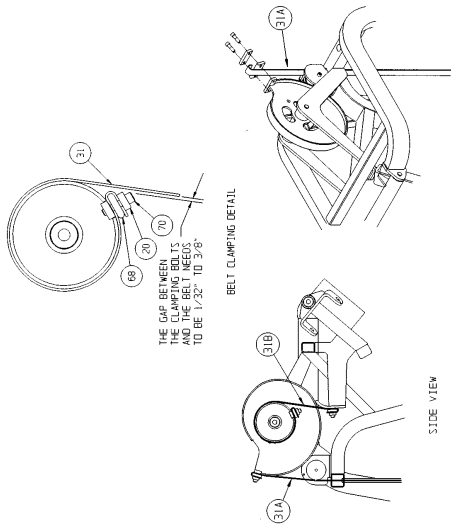

ROW / REAR DELT - SINGLE AXIS

PRODUCT NO. 4521

PARTS LIST

Note: Item D - Weight Stack Belt = 57.5" Long
Item D - Input Arm Belt = 32" Long

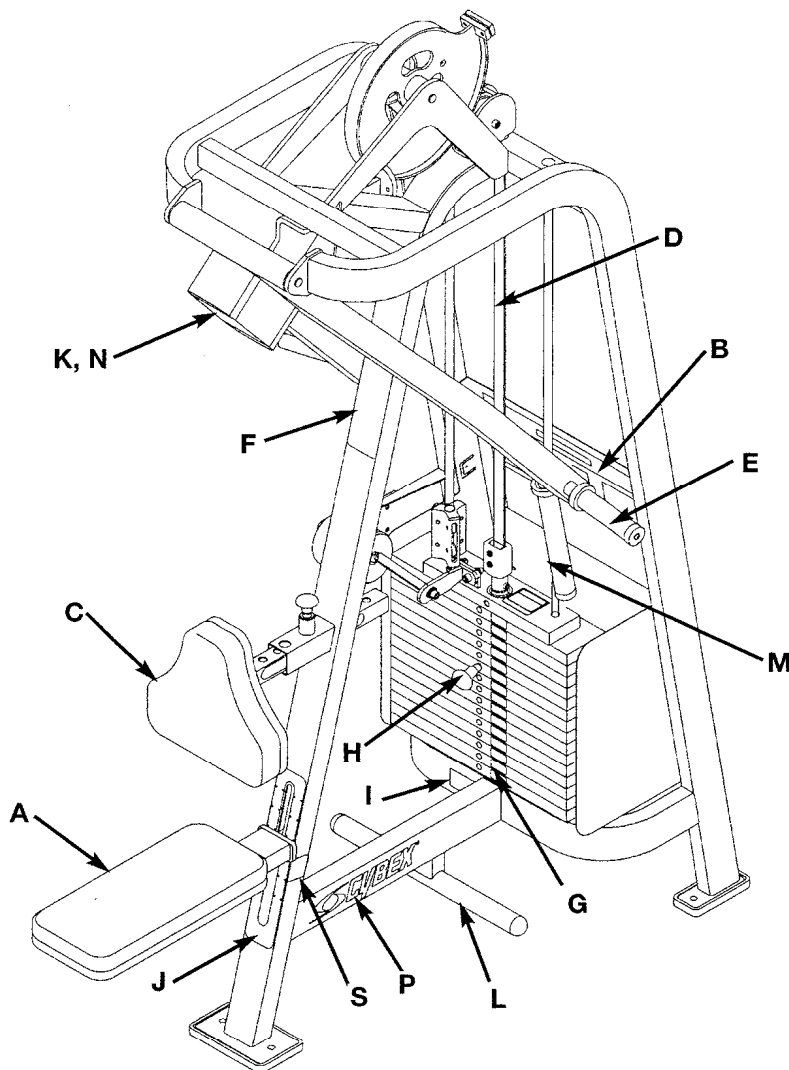

See exploded-view diagram for items: O (#69), Q (#77 K) and R (#83).

DESCRIPTION	PART NO.	DESCRIPTION	PART NO.
A. Seat Cushion	4800-024	L. Rubber Grip	02022
B. Placard Decal	4521-598	M. Grip.....	4605-502
C. Chest Cushion	4800-026	N. Wear Cover (Item K)	4800-101
D. Belt.....	GB000202	O. Cybex Decal Blk/Plm ...	3900-391
E. Grip.....	4605-501	O. Cybex Decal Wht/Wht...	3900-419
F. Warning Decal	4605-381	P. Cybex Decal Blk/Plm ...	3900-390
G. Weight Plate Decal.....	4605-388	P. Cybex Decal Wht/Wht ..	3900-415
H. Weight Selector Pin.....	BH030207	Q. Caution Decal	4605-424
I. Serial Number Decal		R. Adjusting Decal	4520-357
J. Seat Adjustment Decal..	5221-316	S. Caution Decal	4520-362
K. Cushion w/Wear Cover..	4800-071		

4521 - Row / Rear Delt - Single Axis

ITEM	QTY	PART NO.	DESCRIPTION
1	2	01193	Finned Fastener
2	2	02022	Rubber Grip 7.0"
3	2	08001	Plug 1.50
4	1	11040-440	Cybex Knob
5			Removed 8/98
6	1	4520-211	Cushion Tube
7	1	4520-204	Seat Tube
8	1	4520-212	Seat Roller
9	1	4520-208	Frame
10	1	4520-209	Cam
11			Not Used
12	2	4520-331	Roller
13			Removed
14	1	4605-512	Plastic Insert 7.94
15			Not Used
16	1	PR070002	Foot Pad 4.00 x 7.00
17	1	5221-316	Seat Adjustment Decal
18	1	4505-443	Guard
19	1	4521-200	Pivot
20	1	4521-598	Placard Decal
21			Not Used
22			Not Used
23	3	4605-300	Belt Clamp
24	1	4605-322	Detent Pin
25	1	4605-334	Pivot Shaft 13.06
26			Not Used
27	2	PR070003	Foot Pad 2.00 x 5.25
28	4	11090-374	End Cap
29	4	4605-381	Warning Decal
30			Not Used
31	1	4605-388	Weight Plate Decal 10-290
32			Not Used
33	3	4605-394	Belt Clamp
34			Not Used
35			Not Used
36	1	4701-302	VR2 Weight Stack Instr. (not shown)
37			Not Used
38	2	5220-320	Pivot Shaft 7.06
39			Removed 8/98
40	4	BR030210	Retaining Ring 17 mm
41			Not Used
42	1	BR030216	Retaining Ring .875
43	1	BS070201	Com Spring .56 x .66 x 1.50 L
44	1		Serial Number Decal
45	4	FB030232	Radial Brg 17 mm ID (Ext Race)
46 A	57.5"	GB000202	Weight Stack Belt .95" Wide
46 B	32"	GB000202	Input Arm Belt .95" Wide
47	1	GP000209	Pulley Assembly 3.50
48			Not Used
49	2	HC702817	SHCS .375-16 x 1.00
50	6	HC702822	SHCS .375-16 x 1.50
51	3	HC702830	SHCS .375-16 x 2.50
52	1	HN704901	Nylon Locknut .375-16
53			Removed
54			Removed 8/98
55			Not Used
56			Not Used
57	4	HT102214	Tap Screw #10-12 x .625 A (Phil)
58			Not Used
59			Removed 8/98
60			Not Used
61	1	PN090202	Plastic Insert 1.5 Dia x 3.0 x 11 G

ITEM	QTY	PART NO.	DESCRIPTION
62	1	PP090206	Plastic Insert
63	2	PP090210	Plastic Insert 2.00 Sq x 10-14 G
64	1	PP090211	Plastic Insert 1.50 Sq x 10-14 G
65			Not Used
66			Not Used
67 A	2	4605-501	Grip 5.00
67 B	2	4605-502	Grip 9.00
68	1	PU060203	Bumper
69			Removed 3/03
69	1	3900-391	Cybex Decal 11.37 Vert. Blk/Plm
69	1	3900-419	Cybex Decal 11.37 Vert. Wht/Wht
70			Removed 3/03
70	2	3900-390	Cybex Decal 1.57 Horiz. Blk//Plm
70	2	3900-415	Cybex Decal 1.57 Horiz. Wht/Wht
71 A	1	4800-071	Cushion/Wear Cover
71 B	1	4800-101	Wear Cover
72	1	4800-024	Seat Cushion
73	1	4800-026	Chest Cushion
74			Removed 8/98
75			Removed 8/98
76	1	4701-022	Guide Rod Set 58"
76 A	2	4520-304	Weight Rod .625 Dia. x 58.00
76 B	4	BR030214	Retaining Ring .625
76 C	2	HS407100	Spring Washer .65 x .79 x .062 T
76 D	2	PN660200	Plastic Insert 1.00 Dia. x 11G
76 E	2	PR060005	Weight Bumper
77	1	4701-034	Sliding Increment Weight Set
77 A	1	11040-216	Belt Clamp
77 B	1	11040-301	Belt Clamp Insert
77 C	3	4605-390	Increment Weight
77 D			Removed 3/03
77 E	1	BH030207	Weight Selector Pin
77 F	1	FB130208	Bearing Sleeve .68 x .81 1.00 L
77 G	2	HC702817	SHCS .375-16 x 1.00
77 H	2	HC702828	SHCS .375-16 x 2.25
77 I	4	HN704901	Nylon Locknut .375-16
77 J	4	HS347600	Washer, SAE .375
77 K	1	HY740000	Set Screw
77 L	1	4605-424	Caution Decal
77 M	1	4700-240	Weight Mount
77 N	2	4700-318	Increment Weight Rod
77 O	1	4700-319	Frame Mount Increment Weight
77 P	2	4701-001	Top Weight Guide
77 Q	2	4700-321	Rubber Washer
77 R	2	JC702820	SHCS .375-16 x 1.25
77 S	2	HS348300	Split Lockwasher .375
77 T	1	4700-238	Top Weight
77 U	3	HC702816	SHCS .375-16 x .875
78	1	51198	Strength Warranty Sheet (not shown)
79	4	HF449063	Connector Insert .75 x .25-20
80	2	HC702834	SHCS .375-16 x 3.00
81	2	HS347600	Washer .375 SAE
82	2	HC702820	SHCS .375-16 x 1.25
83	1	4520-357	Adjusting Decal
84	1	4520-213	Bracket
85	1	4520-362	Caution Decal
86	2	HS347700	Washer USS .375
87	2	JC702812	SHCS .375-16 x .50
88	14	4000C101	Stack Weight 4 x 18 (not shown)
89	4	11090-376	Handle Grip Ring
90	4	JS347400	Internal Tooth Lockwasher
91	4	JC620422	BHSCS .250-20 x 1.50

ROW / REAR DELT - SINGLE AXIS - 4521

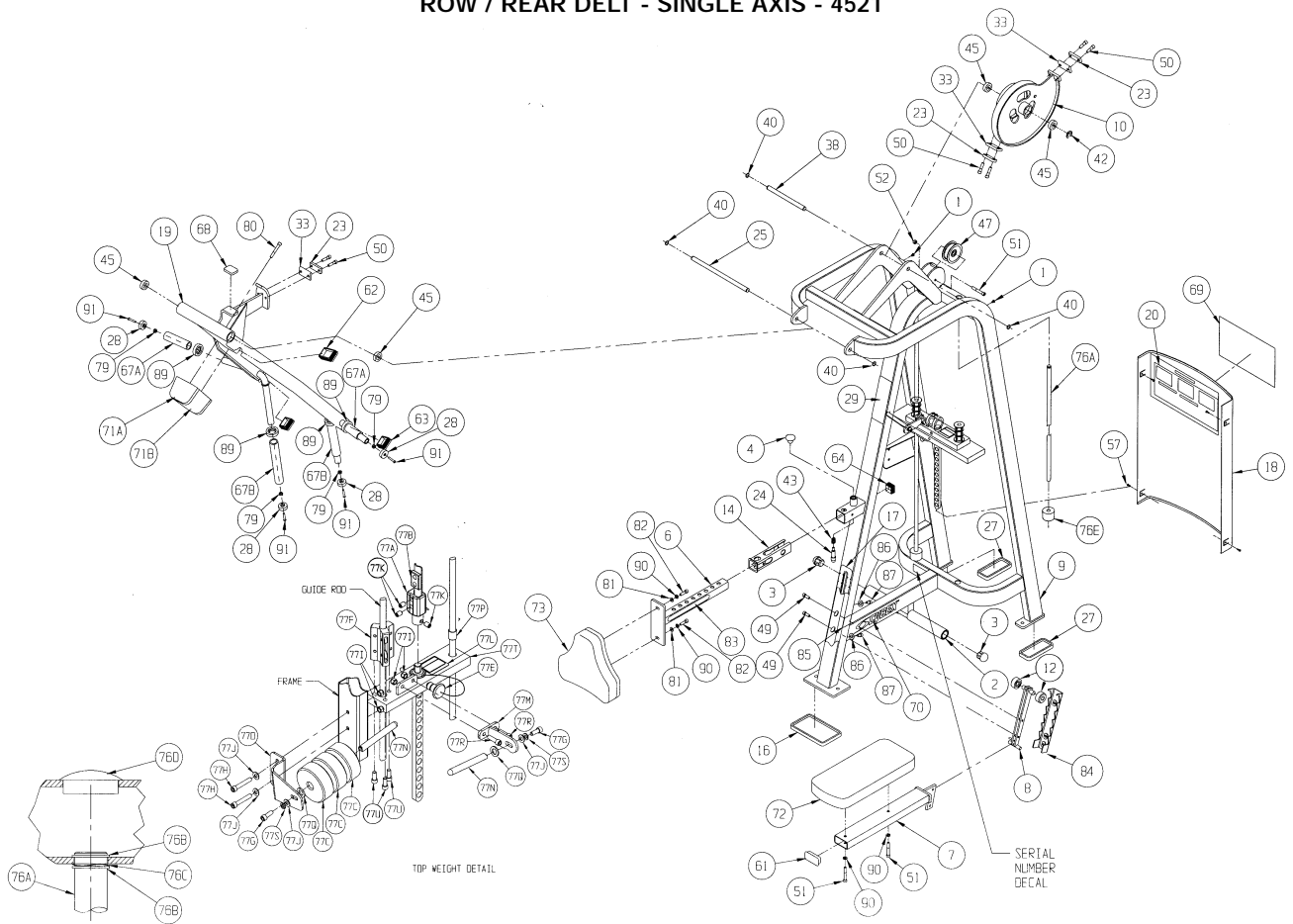

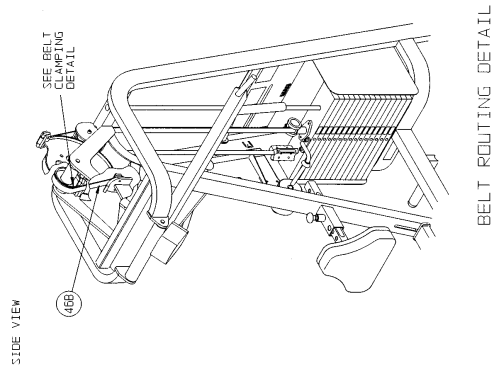
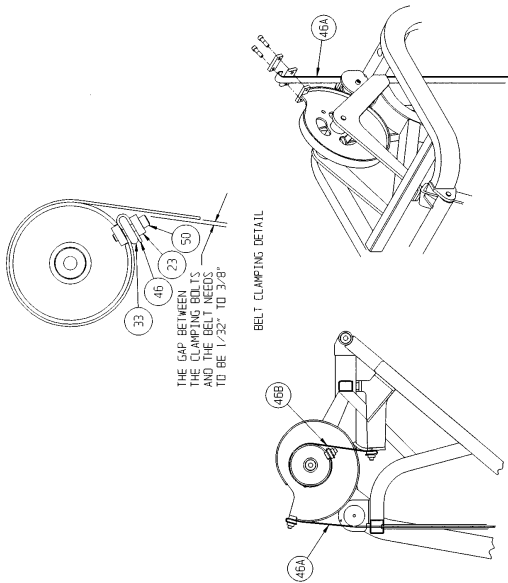

OVERHEAD PRESS - SINGLE AXIS

PRODUCT NO. 4526

PARTS LIST

Note: Item D - Weight Stack Belt = 90.0" Long
Item D - Input Arm Belt = 43.0" Long

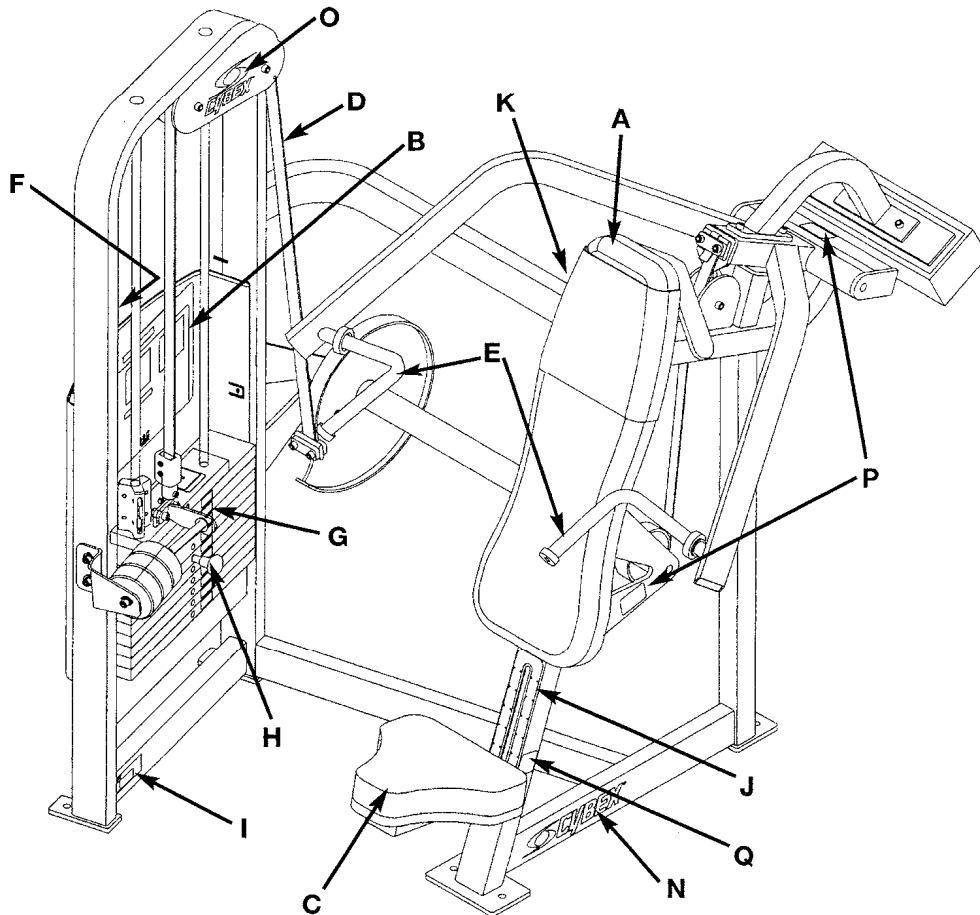

See exploded-view diagram for items: L (#71 K) and M (#65).

DESCRIPTION	PART NO.	DESCRIPTION	PART NO.
A. Back Cushion w/Wear Cover	4800-103	K. Wear Cover (Item A)	4800-106
B. Placard Decal	4526-598	L. Caution Decal	4605-424
C. Seat Cushion	4800-026	M. Cybex Decal Blk/Plm	3900-391
D. Belt	GB000202	M. Cybex Decal Wht/Wht ..	3900-419
E. Grip.....	4605-518	N. Cybex Decal Blk/Plm	3900-390
F. Warning Decal	4605-381	N. Cybex Decal Wht/Wht...	3900-415
G. Weight Plate Decal.....	4605-388	O. Cybex Decal Blk/Plm ...	3900-423
H. Weight Selector Pin.....	BH030207	O. Cybex Decal Wht/Wht ..	3900-424
I. Serial Number Decal		P. Caution Decal	4000Y316
J. Seat Adjustment Decal..	5221-316	Q. Caution Decal.....	4520-362

4526 - Overhead Press - Single Axis

ITEM	QTY	PART NO.	DESCRIPTION
1	1	ZC000001	Counterweight
2			Not Used
3	1	4505-207	Seat
4			Not Used
5	1	4505-327	Pivot Shaft 35.72
6	1	PR070001	Foot Pad 2.50 x 4.25
7	1	4520-212	Seat Roller
8	2	4520-331	Roller
9			Removed
10	1	PR070002	Foot Pad 4.00 x 7.00
11	1	5221-316	Seat Adjustment Decal
12	1	4525-203	Counterweight Bracket
13	1	4526-203	Frame
14	1	4526-202	Cam
15	1	4526-201	Arm
16	1	4526-598	Placard Decal
17	1	4505-431	Guard
18			Not Used
19			Not Used
20	3	4605-300	Belt Clamp
21	1	4605-334	Pivot Shaft 13.06
22			Not Used
23	2	PR070003	Foot Pad 2.00 x 5.25
24	2	11090-374	End Cap
25	1	4605-381	Warning Decal
26			Not Used
27			Not Used
28	1	4605-388	Weight Plate Decal 10-290
29			Not Used
30	3	4605-394	Belt Clamp
31			Removed 8/98
32			Not Used
33			Not Used
34	1	4701-302	VR2 Weight Stack Instr (not shown)
35			Not Used
36			Not Used
37	4	BR030210	Retaining Ring 17 mm
38			Not Used
39			Not Used
40	4	FB030232	Radial Brg 17 mm ID (Ext Race)
41 A	90"	GB000202	Weight Stack Belt .95" wide
41 B	43"	GB000202	Rear Belt .95" wide
42	3	GP000209	Pulley Assembly 3.50
43			Not Used
44	4	HC702817	SHCS .375-16 x 1.00
45	6	HC702822	SHCS .375-16 x 1.50
46			Not Used
47	7	HC702830	SHCS .375-16 x 2.50
48	3	HN704901	Nylon Locknut .375-16
49			Removed
50	4	08007	Nylon Washer .515 x 1.00 x .062T
51			Not Used
52			Not Used
53	4	HT102214	Tap Screw #10-12 x .625A (Phil)
54			Not Used
55			Not Used
56	4	HN784000	Hex Nut .500-13
57			Not Used
58	2	PN660201	Hole Plug

ITEM	QTY	PART NO.	DESCRIPTION
59	1	PP090202	Plastic Insert 1.5x3.0 11 G
60	2	PP090210	Plastic Insert 20sqx10-14G
61			Not Used
62			Not Used
63	2	4605-518	Grip 15" long
64	1	PU060204	Bumper
65			Removed 3/03
65	1	3900-391	Cybox Decal 11.37 Vert. Blk/Plm
65	1	3900-419	Cybox Decal 11.37 Vert. Wht/Wht
66			Removed 3/03
66	1	3900-390	Cybox Decal 1.57 Horiz. Blk/Plm
66	1	3900-415	Cybox Decal 1.57 Horiz. Wht/Wht
67	1	3900-423	Cybox Decal 4.85 Vert. Blk/Plm
67	1	3900-424	Cybox Decal 4.85 Vert. Wht/Wht
67			Removed 3/03
68	1	4800-026	Seat Cushion
69 A	1	4800-009	Back Cushion w/Wear Cover
69 B	1	4800-092	Wear Cover
70	1	4701-021	Weight Stack Guide Rod Set
70 A	2	4505-319	Weight Stack Guide Rod
70 B	4	BR030214	Retaining Ring .625
70 C	2	HS407100	Spring Washer .65 x .79 x .062 T
70 D	2	PN660200	Plastic Insert 1.00 Dia x 11 G
70 E	2	PR060005	Weight Bumper
71	1	4701-030	Sliding Increment Weight Set
71 A	1	11040-216	Belt Clamp
71 B	1	11040-301	Belt Clamp Insert
71 C	3	4605-390	Increment Weight
71 D			Removed 3/03
71 E	1	BH030207	Weight Selector Pin
71 F	1	FB130208	Bearing Sleeve .68 x .81 1.00 L
71 G	2	HC702817	SHCS .375-16 x 1.00
71 H	2	HC702828	SHCS .375-16 x 2.25
71 I	4	HN704901	Nylon Locknut .375-16
71 J	4	HS347600	Washer, SAE .375
71 K	1	HY740000	Set Screw
71 L	1	4605-424	Caution Decal
71 M	1	4700-240	Weight Mount
71 N	2	4700-318	Increment Weight Rod
71 O	1	4700-319	Frame Mount Increment Weight
71 P	2	4701-001	Top Weight Guide
71 Q	2	4700-321	Rubber Washer
71 R	2	JC702820	SHCS .375-16 x 1.25
71 S	2	HS348300	Split Lockwasher .375
71 T	1	4700-239	Top Weight
71 U	3	HC702816	SHCS .375-16 x .875
72	2	4000Y316	Caution Decal
73	2	HF449063	Tube Insert
74	1	51198	Strength Warranty Sheet (not shown)
75	2	HC702834	SHCS .375-16 x 3.00
76	1	4520-213	Bracket
77	1	4520-362	Caution Decal
78	2	HS347700	Washer USS .375
79	2	JC702812	SHCS .375-16 x .50
80	9	4000C101	Stack Weight 4 x 18 (not shown)
81	2	11090-376	Handle Grip Ring
82	4	JS347400	Internal Tooth Lockwasher
83	4	JC620422	BHSCS .250-20 x 1.50

OVERHEAD PRESS - SINGLE AXIS - 4526

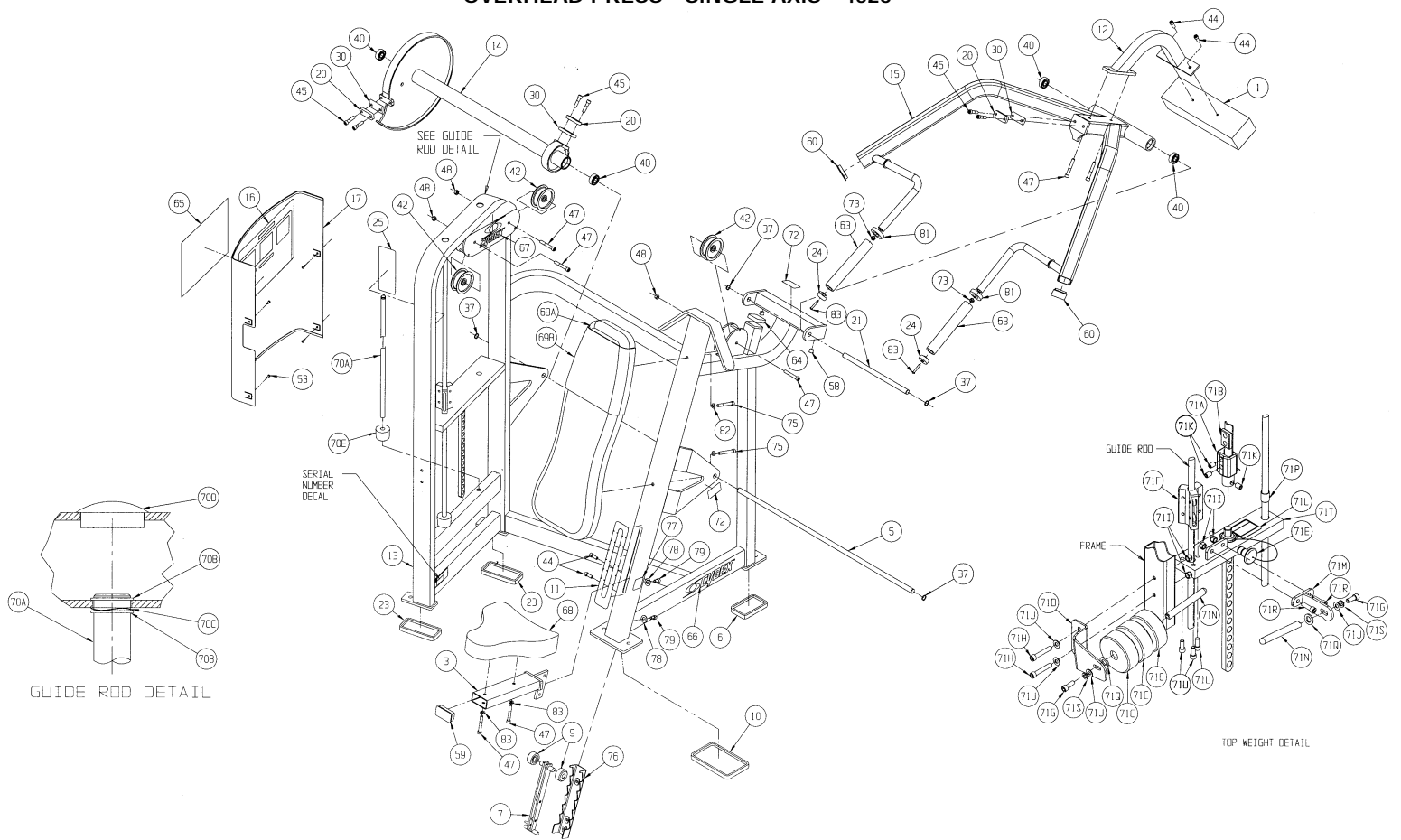

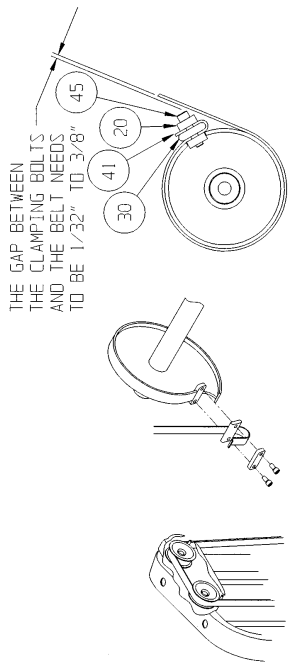

BELT CLAMPING DETAIL

BELT ROUTING DETAIL

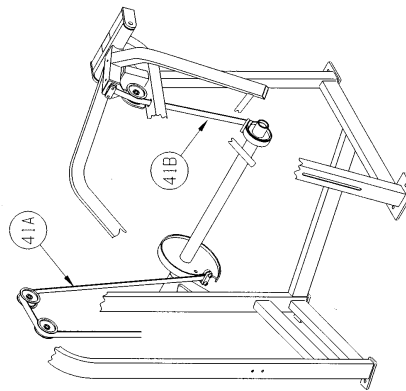

BELT ROUTING DETAIL

OVERHEAD PRESS - DUAL AXIS

PRODUCT NO. 4527

PARTS LIST

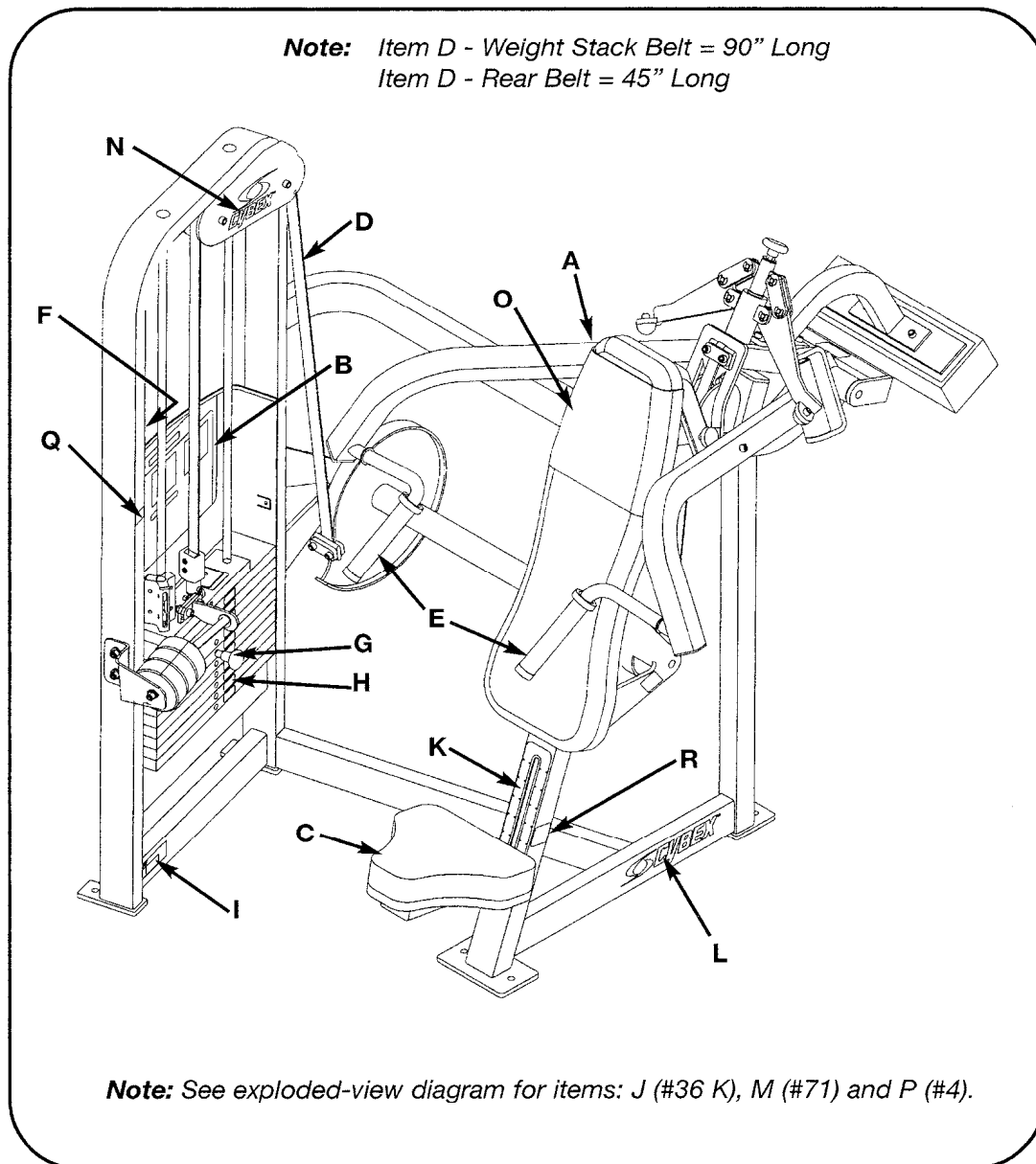

DESCRIPTION	PART NO.	DESCRIPTION	PART NO.
A. Back Cushion w/Wear Cover.....	4800-103	K. Seat Adjustment Decal..	5221-316
B. Placard Decal.....	4527-598	L. Cybex Decal Blk/Plm	3900-390
C. Seat Cushion.....	4800-026	L. Cybex Decal Wht/Wht ..	3900-415
D. Belt.....	GB000202	M. Cybex Decal Blk/Plm ...	3900-391
E. Grip 12.25" Long	4605-503	M. Cybex Decal Wht/Wht ..	3900-419
F. Warning Decal.....	4605-381	N. Cybex Decal Blk/Plm	3900-423
G. Weight Plate Decal.....	4605-388	N. Cybex Decal Wht/Wht ..	3900-424
H. Weight Selector Pin.....	BH030207	O. Wear Cover (Item A)	4800-106
I. Serial Number Decal		P. Caution Decal.....	4000Y316
J. Caution Decal.....	4605-424	Q. Caution Decal.....	5221-319
		R. Caution Decal.....	4520-362

4527 - Overhead Press - Dual Axis

ITEM	QTY	PART NO.	DESCRIPTION	ITEM	QTY	PART NO.	DESCRIPTION
1	1	PP460012	Knob	36 T	1	4700-239	Top Weight
2			Not Used	36 U	3	HC702816	SHCS .375-16 x .875
3	12	08017	Retaining Ring .375	37	1	4701-302	VR2 Weight Stack Instr. (not shown)
4	1	4000Y316	Caution Decal	38	2	5220-320	Pivot Shaft 7.06
5	1	4505-207	Seat	39	1	5221-316	Seat Adjustment Decal
6	1	4505-327	Pivot Shaft 35.72	40	1	5221-319	Caution Decal
7	6	4505-331	Bumper 1.50 Dia	41	8	BR030210	Retaining Ring 17 mm
8	1	51198	Strength Warranty Sheet (not shown)	42			Removed
9	1	4507-201	Slide	43			Removed 5/99
10	6	4507-301	Pin	44	8	FB030232	Radial Brg 17 mm ID (Ext Race)
11	4	4507-302	Link Bar	45	2	FB130212	Flange Brg .75 x .88 x .75 L
12	1	4507-310	Flat Washer .647 x 1.25 x .105 T	46 A	90"	GB000202	Weight Stack Belt .95" wide
13	1	4520-212	Seat Roller	46 B	45"	GB000202	Rear Belt .95" wide
14	2	4520-331	Roller	47	3	GP000209	Pulley Assembly 3.50
15			Removed	48	1	HC700915	FHSCS .375-16 x .75
16	1	4525-203	Counterweight Bracket	49	4	HC702815	SHCS .375-16 x .750
17	1	4525-204	Arm (Right Hand)	50	4	HC702817	SHCS .375-16 x 1.00
18	1	4525-205	Arm (Left Hand)	51	6	HC702822	SHCS .375-16 x 1.50
19	1	4526-203	Frame	52	9	HC702830	SHCS .375-16 x 2.50
20	1	4526-202	Cam	53	2	HF449063	Connector Insert 3/4 x 1/4 - 20
21	2	4525-318	Slide Plate	54	1	HN704000	Hex Nut .375-16
22	2	4525-329	Arm Block	55	3	HN704901	Nylon Locknut .375-16
23	1	4527-201	Pivot	56			Removed 5/99
24	1	4527-202	Stop (Right Hand)	57			Removed
25	1	4527-203	Stop (Left Hand)	58	2	HS347700	Washer USS .375
26	1	4527-300	Adjustment Screw (RH)	59	4	HT102214	Tap Screw #10-12 x .625 A (Phil)
27	1	4527-598	Placard Decal	60	2	PN660201	Hole Plug
28	1	4505-431	Guard	61	1	PP080202	Plastic Insert 1.19 Dia - 11 G
29	3	4605-300	Belt Clamp	62	1	PP090202	Plastic Insert 1.5 x 3.0 - 11 G
30	1	4605-334	Pivot Shaft 13.06	63	2	PP090210	Plastic Insert 2.00 Sq x 10-14 G
31	1	4605-381	Warning Decal	64			Not Used
32	1	4605-388	Weight Plate Decal 10-290	65	1	PR070001	Foot Pad 2.50 x 4.25
33	3	4605-394	Belt Clamp	66	1	PR070002	Foot Pad 4.00 x 7.00
34	2	11090-374	End Cap	67	2	PR070003	Foot Pad 2.00 x 5.25
35	1	4701-021	Weight Stack Guide Rod Set	68	2	4605-503	Grip 12.25
35 A	2	4505-319	Weight Stack Guide Rod	69	1	PU060204	Bumper
35 B	4	BR030214	Retaining Ring .625	70			Removed 3/03
35 C	2	HS407100	Spring Washer .65 x .79 x .062T	70	1	3900-390	Cybex Decal 1.57 Horiz. Blk/Plm
35 D	2	PN660200	Plastic Insert 1.00 Dia. x 11 G	70	1	3900-415	Cybex Decal 1.57 Horiz. Wht/Wht
35 E	2	PR060005	Weight Bumper	71			Removed 3/03
36	1	4701-030	Sliding Increment Weight Set	71	1	3900-391	Cybex Decal 11.37 Vert. Blk/Plm
36 A	1	11040-216	Belt Clamp	71	1	3900-419	Cybex Decal 11.37 Vert. Wht/Wht
36 B	1	11040-301	Belt Clamp Insert	72	1	3900-423	Cybex Decal 4.85 Vert. Blk/Plm
36 C	3	4605-390	Increment Weight	72	1	3900-424	Cybex Decal 4.85 Vert. Wht/Wht
36 D			Removed 3/03	72			Removed 3/03
36 E	1	BH030207	Weight Selector Pin	73	1	4800-026	Seat Cushion
36 F	1	FB130208	Bearing Sleeve .68 x .81 1.00 L	74 A	1	4800-009	Back Cushion w/Wear Cover
36 G	2	HC702817	SHCS .375-16 x 1.00	74 B	1	4800-092	Wear Cover
36 H	2	HC702828	SHCS .375-16 x 2.25	75			Not Used
36 I	4	HN704901	Nylon Locknut .375-16	76	1	ZC000001	Counterweight
36 J	4	HS347600	Washer, SAE .375	77			Removed
36 K	1	HY740000	Set Screw	78	2	HC702834	SHCS .375-16 x 3.00
36 L	1	4605-424	Caution Decal	79	1	4520-213	Bracket
36 M	1	4700-240	Weight Mount	80	1	4520-362	Caution Decal
36 N	2	4700-318	Increment Weight Rod	81	2	HS347700	Washer USS .375
36 O	1	4700-319	Frame Mount Increment Weight	82	2	JC702812	SHCS .375-16 x .50
36 P	2	4701-001	Top Weight Guide	83	9	4000C101	Stack Weight 4 x 18 (not shown)
36 Q	2	4700-321	Rubber Washer	84	2	11090-376	Handle Grip Ring
36 R	2	JC702820	SHCS .375-16 x 1.25	85	4	JS347400	Internal Tooth Lockwasher
36 S	2	HS348300	Split Lockwasher .375	86	2	JC620422	BHSCS .250-20 x 1.50

OVERHEAD PRESS - DUAL AXIS - 4527

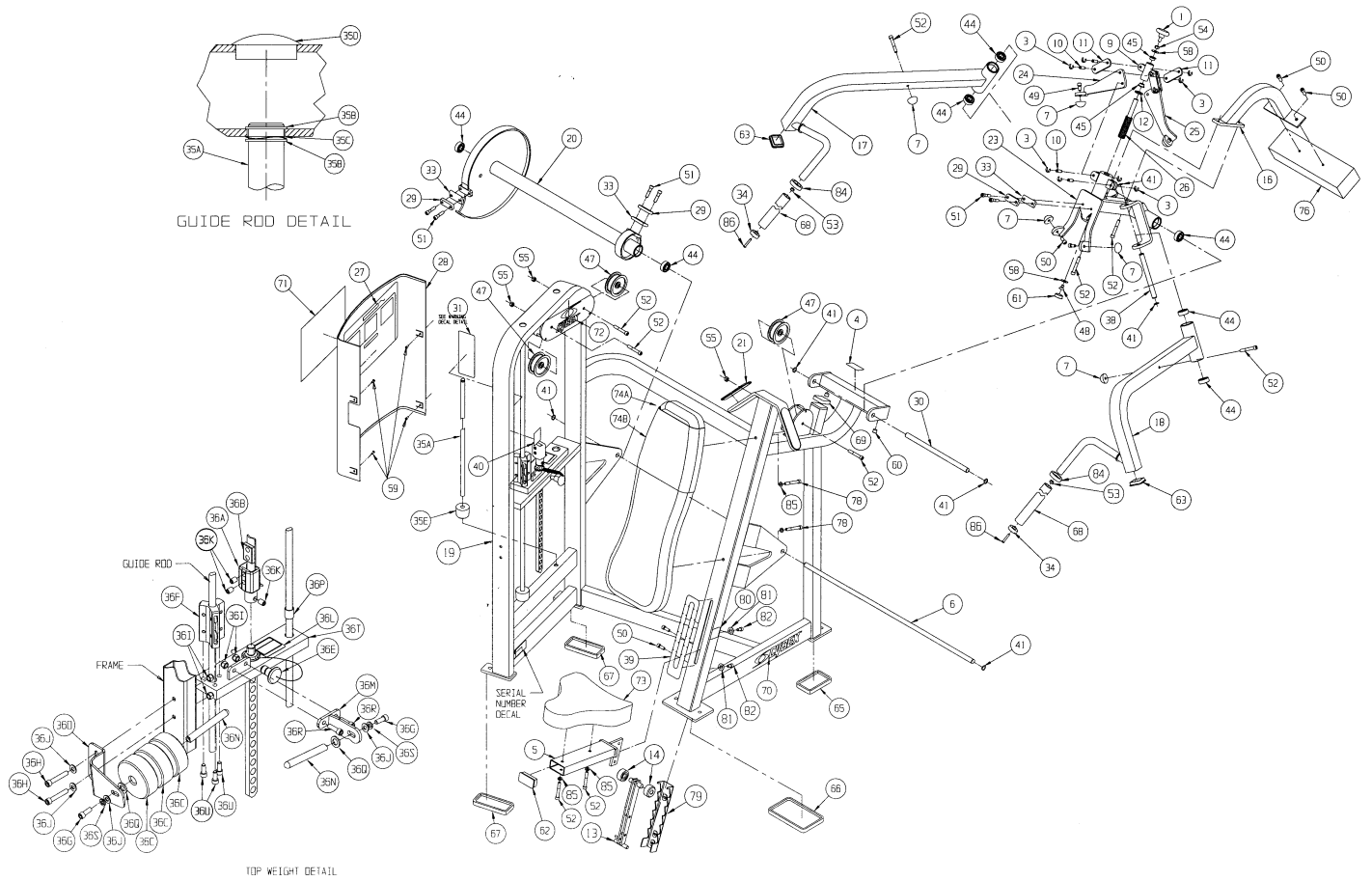

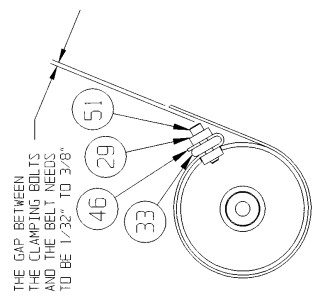

BELT CLAMPING DETAIL

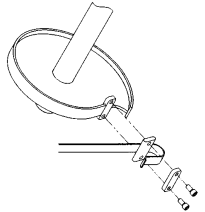

BELT ROUTING DETAIL

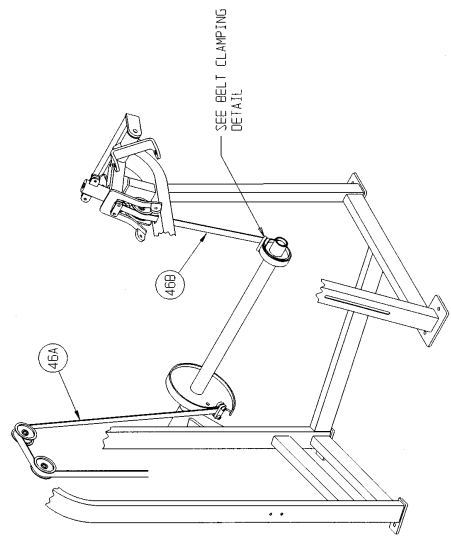
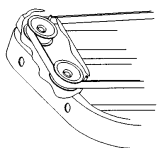

BELT ROUTING DETAIL

LATERAL RAISE

PRODUCT NO. 4530

PARTS LIST

Note: Item D - Weight Stack Belt = 65" Long
Item D - Input Arm Belt = 44" Long

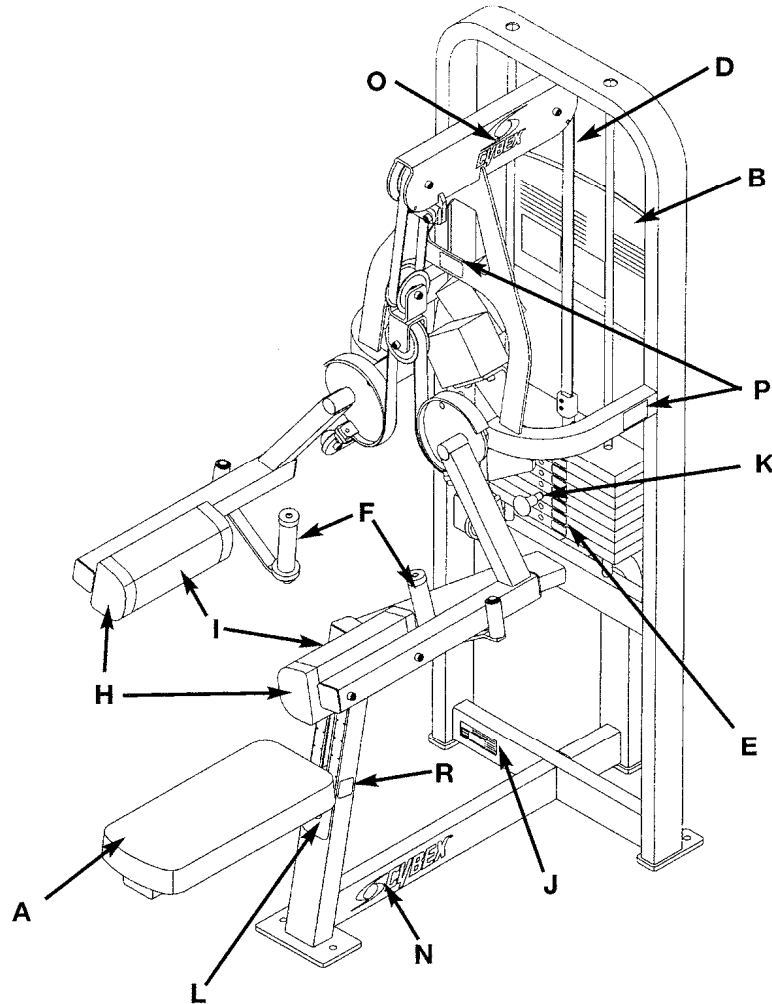

See exploded-view diagram for items: C (#22), G (#50), M (#28 K) and Q (#50).

DESCRIPTION	PART NO.	DESCRIPTION	PART NO.
A. Seat Cushion.....	4800-024	K. Weight Selector Pin.....	BH030207
B. Placard Decal.....	4530-598	L. Seat Adjustment Decal..	5221-316
C. Warning Decal.....	4605-381	M. Caution Decal.....	4605-424
D. Belt.....	GB000202	N. Cybex Decal Blk/Plm	3900-390
E. Weight Plate Decal.....	4605-388	N. Cybex Decal Wht/Wht ..	3900-415
F. Grip 12.25" Long	4605-501	O. Cybex Decal Blk/Plm	3900-423
G. Cybex Decal Blk/Plm ...	3900-391	O. Cybex Decal Wht/Wht ..	3900-424
G. Cybex Decal Wht/Wht ..	3900-419	Q. Cybex Decal Blk/Plm	3900-391
H. Arm Cushion w/Wear-Cover.....	4800-023	Q. Cybex Decal Wht/Wht...	3900-419
I. Wear Cover.....	4800-095	P. Caution Decal.....	4000Y316
J. Serial Number Decal		R. Caution Decal.....	4520-362

4530 - Lateral Raise

ITEM	QTY	PART NO.	DESCRIPTION	ITEM	QTY	PART NO.	DESCRIPTION
1			Removed	28 S	2	HS348300	Split Lockwasher .375
2	2	4505-331	Bumper 1.50 Dia	28 T	1	4700-239	Top Weight
3	2	4507-309	Flat Washer .391 x 1.125 x .105	28 U	3	HC702816	SHCS .375-16 x .875
4	1	4520-212	Seat Roller	29	1	4701-302	VR2 Weight Stack Instr (not shown)
5	2	4520-331	Roller	30	1	5221-316	Seat Adjustment Decal
6			Removed	31	2	BR030210	Retaining Ring (17mm)
7	1	PR070002	Rubber Pad 4.00 x 7.00	32	2	BR110201	E-Ring
8	1	51198	Strength Warranty Sheet (not shown)	33	1		Removed
9	1	4530-200	Frame	34	4	FB030235	Ral Brg. 42mm OD x 25mm
10	1	4530-201	Arm (LH)	35	4	FB130207	Flg. Brg.17mm x 19mm x 25mm
11	1	4530-202	Arm (RH)	36 A	65.0"	GB000202	Weight Stack Belt .95 Wide
12	1	4530-203	Handle (LH)	36 B	44.0"	GB000202	Input Arm Belt .95 Wide
13	1	4530-204	Handle (RH)	37	4	GB000209	Pulley Assembly 3.50
14	1	4530-205	Pulley Mount	38	4	HC702815	SHCS .375-16 x .750
15	1	4530-206	Seat	39	6	HC702817	SHCS .375-16 x 1.00
16	2	4530-322	Counterweight	40	6	HC702822	SHCS .375-16 x 1.50
17	2	4530-327	Bracket	41	6	HC702830	SHCS .375-16 x 2.50
18	1	4505-436	Guard	42	2	HF449063	Connector Insert .75 x .25-20
19	1	4530-598	Placard Decal	43	4	HN704901	Nylon Locknut .375-16
20	3	4605-300	Belt Clamp	44			Removed 5/99
21	3	PR070003	Foot Pad 2.00 x 5.25	45			Removed
22	1	4605-381	Warning Decal	46	4	HT102214	Tap Screw #10-12 x.625 A (Phil)
23			Not Used	47			Not Used
24	1	4605-388	Weight Plate Decal 10-290	48	1	PP090202	Plastic Insert 1.5 x 3.0 11 G
25	3	4605-394	Belt Clamp	49	4	PP090210	Plastic Insert 2.00 sq x 10-14 G
26	2	11090-374	End Cap	50			Removed 3/03
27	1	4701-020	Weight Stack Guide Rod Set	50	1	3900-391	Cybox Decal 11.37 Vert. Blk/Plm
27 A	2	4535-329	Weight Stack Guide Rod	50	1	3900-419	Cybox Decal 11.37 Vert Wht/Wht
27 B	4	BR030214	Retaining Ring .625	51	2	4605-501	Grip
27 C	2	HS407100	Spring Washer .65 x .79 x .062 T	52			Removed 3/03
27 D	2	PN660200	Plastic Insert 1.00 Dia x 11 G	52	2	3900-390	Cybox Decal 1.57 Horiz. Blk/Plm
27 E	2	PR060005	Weight Bumper	52	2	3900-415	Cybox Decal 1.57 Horiz. Wht/Wht
28	1	4701-030	Sliding Increment Weight Set	53	2	3900-423	Cybox Decal 4.85 Vert. Blk/Plm
28 A	1	11040-216	Belt Clamp	53	2	3900-424	Cybox Decal 4.85 Vert. Wht/V
28 B	1	11040-301	Belt Clamp Insert	53			Removed 3/03
28 C	3	4605-390	Increment Weight	54	1	4800-024	Seat Cushion
28 D			Removed 3/03	55 A	2	4800-023	Arm Cushion w/Wear Cover
28 E	1	BH030207	Weight Selector Pin	55 B	2	4800-095	Wear Cover
28 F	1	4701-001	Top Weight Guide	56	1	4530-330	Spacer
28 G	2	HC702817	SHCS .375-16 x 1.00	57	1	4530-331	Spacer
28 H	2	HC702828	SHCS .375-16 x 2.25	58	3	4000Y316	Caution Decal
28 I	4	HN704901	Nylon Locknut .375-16	59	4	HC702834	SHCS .375-16 x 3.00
28 J	4	HS347600	Washer, SAE .375	60	1	4520-213	Bracket
28 K	3	HY740000	Set Screw	61	1	4520-362	Caution Decal
28 L	1	4605-424	Caution Decal	62	2	HS347700	Washer USS .375
28 M	1	4700-240	Weight Mount	63	2	JC702812	SHCS .375-16 x .50
28 N	2	4700-318	Increment Weight Rod	64	9	4000C101	Stack Weight 4 x 18 (not shown)
28 O	1	4700-319	Frame Mount Increment Weight	65	2	11090-376	Handle Grip Ring
28 P	1	FB130208	Bearing Sleeve .68 x .81 1.00 L	66	6	JS347400	Internal Tooth Lockwasher
28 Q	2	4700-321	Rubber Washer	67	2	JC620422	BHSCS .250-20 x 1.50
28 R	2	JC702820	SHCS .375-16 x 1.25				

LATERAL RAISE - 4530

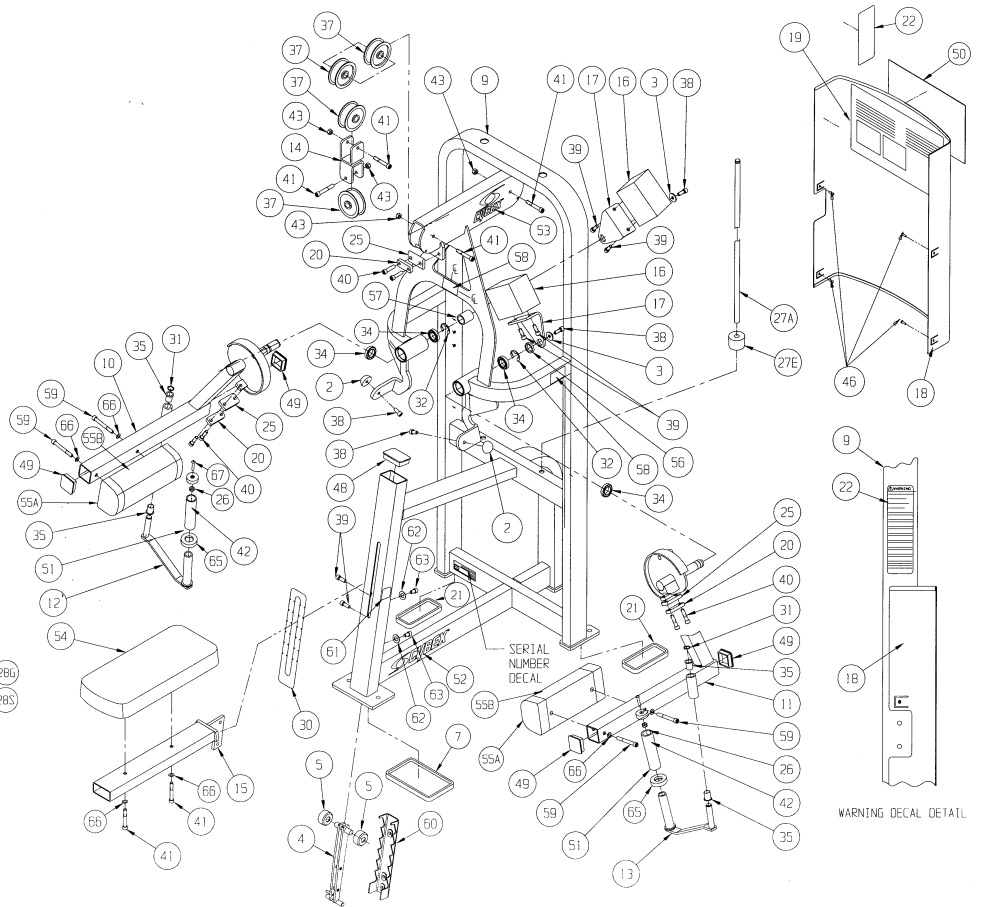
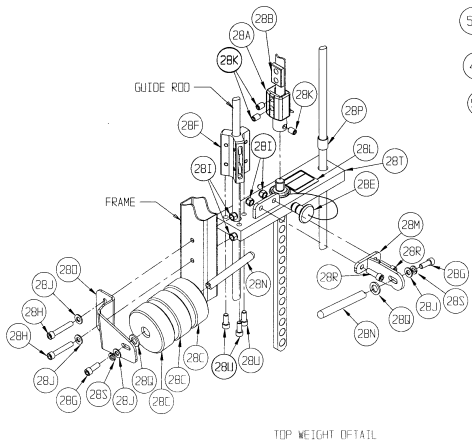
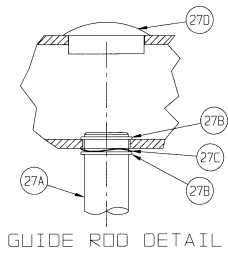

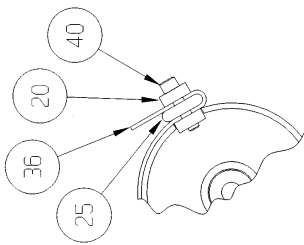

BELT CLAMPING DETAIL

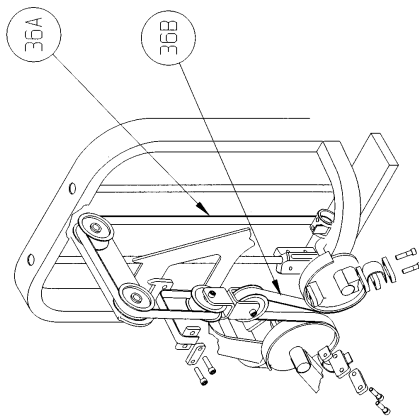

BELT ROUTING DETAIL

ARM CURL

PRODUCT NO. 4535

PARTS LIST

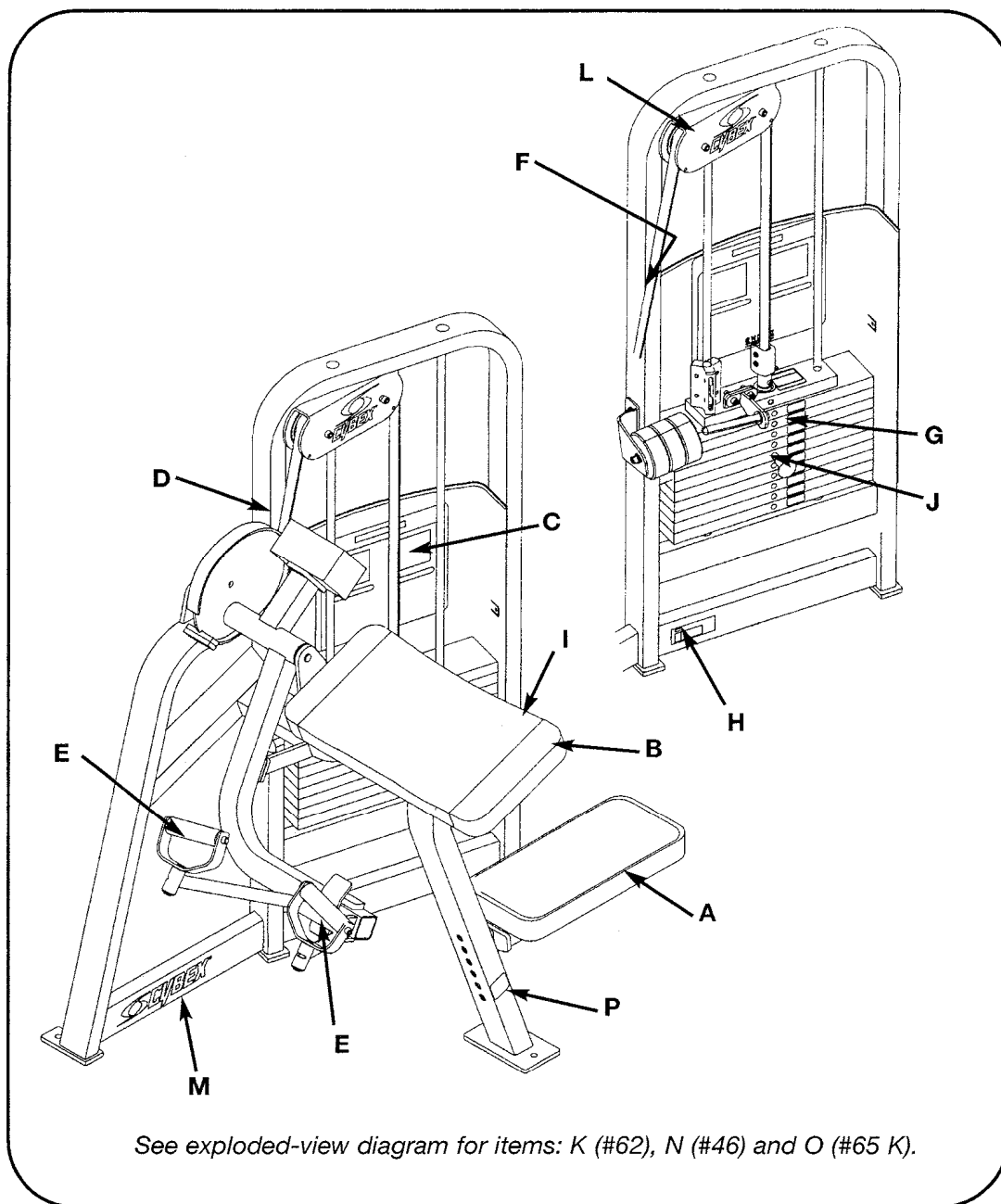

See exploded-view diagram for items: K (#62), N (#46) and O (#65 K).

DESCRIPTION	PART NO.	DESCRIPTION	PART NO.
A. Seat Cushion	4800-024	J. Weight Selector Pin.....	BH030207
B. Arm Cushion w/Wear Cover	4800-008	K. Seat Adjustment Decal..	5221-316
C. Placard Decal	4535-325	L. Cybex Decal Blk/Plm	3900-423
D. Belt 70.0" Long	GB000202	L. Cybex Decal Wht/Wht ..	3900-424
E. Grip 5.2" Long	4605-504	M. Cybex Decal Blk/Plm	3900-390
F. Warning Decal.....	4605-381	M. Cybex Decal Wht/Wht ..	3900-415
G. Weight Plate Decal	4605-388	N. Cybex Decal Blk/Plm	4605-391
H. Serial Number Decal		N. Cybex Decal Wht/Wht ..	4605-419
I. Wear Cover (Item A)	4800-091	O. Caution Decal.....	4605-424
		P. Caution Decal.....	4520-362

4535 - Arm Curl

ITEM	QTY	PART NO.	DESCRIPTION
1	1	4800-024	Seat Cushion
2	1	4520-212	Seat Roller
3	2	4520-331	Roller
4			Removed
5	1	PR070002	Foot Pad 4.00 x 7.00
6 A	1	4800-008	Arm Cushion w/Wear Cover
6 B	1	4800-091	Wear Cover
7	1	4535-200	Frame
8	1	4535-201	Pivot Arm
9	1	4535-202	Cam Arm
10	2	4535-204	Pivot Handle
11	1	4535-205	Seat
12	1	4535-324	Counterweight
13	1	4535-325	Placard Decal
14	2	4535-327	Long Pivot Pin
15	1	4535-328	Short Pivot Pin
16	1	4701-020	Weight Stack Guide Rod Set
16 A	2	4535-329	Weight Stack Guide Rod
16 B	4	BR030214	Retaining Ring .625
16 C	2	HS407100	Spring Washer .65 x .79 x .062 T
16 D	2	PN660200	Plastic Insert 1.00 Dia x 11 G
16 E	2	PR060005	Weight Bumper
17	2	4535-330	Pivot Handle Tube
18			Not Used
19	1	4605-300	Belt Clamp
20	1	4605-334	Pivot Shaft 13.06
21	3	PR070003	Foot Pad 2.00 x 5.25
22	2	BR030210	Retaining Ring 17 mm
23	2	BR030214	Retaining Ring .625
24			Not Used
25	2	FB030232	Radial Brg 17 mm ID (Ext. Race)
26	10	FB130205	Flange Brg .62 x .75 x .38 L
27	70"	GB000202	Belt .95" Wide
28	2	GP000209	Pulley Assembly 3.50
29			Removed
30	10	HC702817	SHCS .375-16 x 1.00
31	4	HC702830	SHCS .375-16 x 2.50
32	2	HC702834	SHCS .375-16 x 3.00
33	2	HN704901	Nylon Locknut .375-16
34	2	HP286716	Roll Pin .188 x .75
35			Removed
36	2	JS407100	Machinery Bushing .625
37	1	PP090202	Plastic Insert 1.50 x 3.00 x 11 G
38	1	PP090210	Plastic Insert 2..00 Sq x 10-14 G
39			Removed
40	2	4605-504	Grip 5.2 Long
41	1	PU060203	Bumper
42	2	08002	Bumper
43	1	4505-431	Guard
44	1	4605-381	Warning Decal
45	1	3900-423	Cybox Decal 4.85 Vert. Blk/Plm
45	1	3900-424	Cybox Decal 4.85 Vert. Wht/Wht
45			Removed 3/03
46			Removed 3/03
46	1	3900-391	Cybox Decal 11.37 Vert. Blk/Plm

ITEM	QTY	PART NO.	DESCRIPTION
46	1	3900-419	Cybox Decal 11.37 Vert. Wht/Wht
47			Not Used
48	4	HT102214	Tap Screw #10-12 x .625 A (Ph.,
49	1	PP090206	Plastic Insert 2.00 x 3.00 x 11 G
50			Removed 8/98
51			Not Used
52			Not Used
53	1	4605-388	Weight Plate Decal 10-290
54			Not Used
55			Removed
56			Not Used
57			Not Used
58	2	HC702822	SHCS .375-16 x 1.50
59			Not Used
60			Not Used
61			Not Used
62	1	5221-316	Seat Adjustment Decal
63	1	4605-394	Belt Clamp
64			Removed 8/98
65	1	4701-030	Sliding Increment Weight Set
65 A	1	11040-216	Belt Clamp
65 B	1	11040-301	Belt Clamp Insert
65 C	3	4605-390	Increment Weight
65 D			Removed 3/03
65 E	1	BH030207	Weight Selector Pin
65 F	1	FB130208	Flange Sleeve .68 x .81 1.00 L
65 G	2	HC702817	SHCS .375-16 x 1.00
65 H	2	HC702828	SHCS .375-16 x 2.25
65 I	4	HN704901	Nylon Locknut .375-16
65 J	4	HS347600	Washer, SAE .375
65 K	1	HY740000	Set Screw
65 L	1	4605-424	Caution Decal
65 M	1	4700-240	Weight Mount
65 N	2	4700-318	Increment Weight Rod
65 O	1	4700-319	Frame Mount Increment Weigh.
65 P	2	4701-001	Top Weight Guide
65 Q	2	4700-321	Rubber Washer
65 R	2	JC702820	SHCS .375-16 x 1.25
65 S	2	HS348300	Split Lockwasher .375
65 T	1	4700-239	Top Weight
65 U	3	HC702816	SHCS .375-16 x .875
66			Not Used
67	2	PP080221	Black Insert .312 Dia
68	1	4701-302	VR2 Weight Stack Instr. (not shown)
69	1	51198	Strength Warranty Sheet (not shown)
70			Removed 3/03
70	1	3900-390	Cybox Decal 1.57 Horiz. Blk/Plm
70	1	3900-415	Cybox Decal 1.57 Horiz. Wht/Wht
71	1	4520-213	Bracket
72	1	4520-362	Caution Decal
73	2	HS347700	Washer USS .375
74	2	JC702812	SHCS .375-16 x .50
75	9	4000C101	Stack Weight 4 x 18 (not shown)
76	4	JS347400	Lockwasher Int Tooth

ARM CURL - 4535

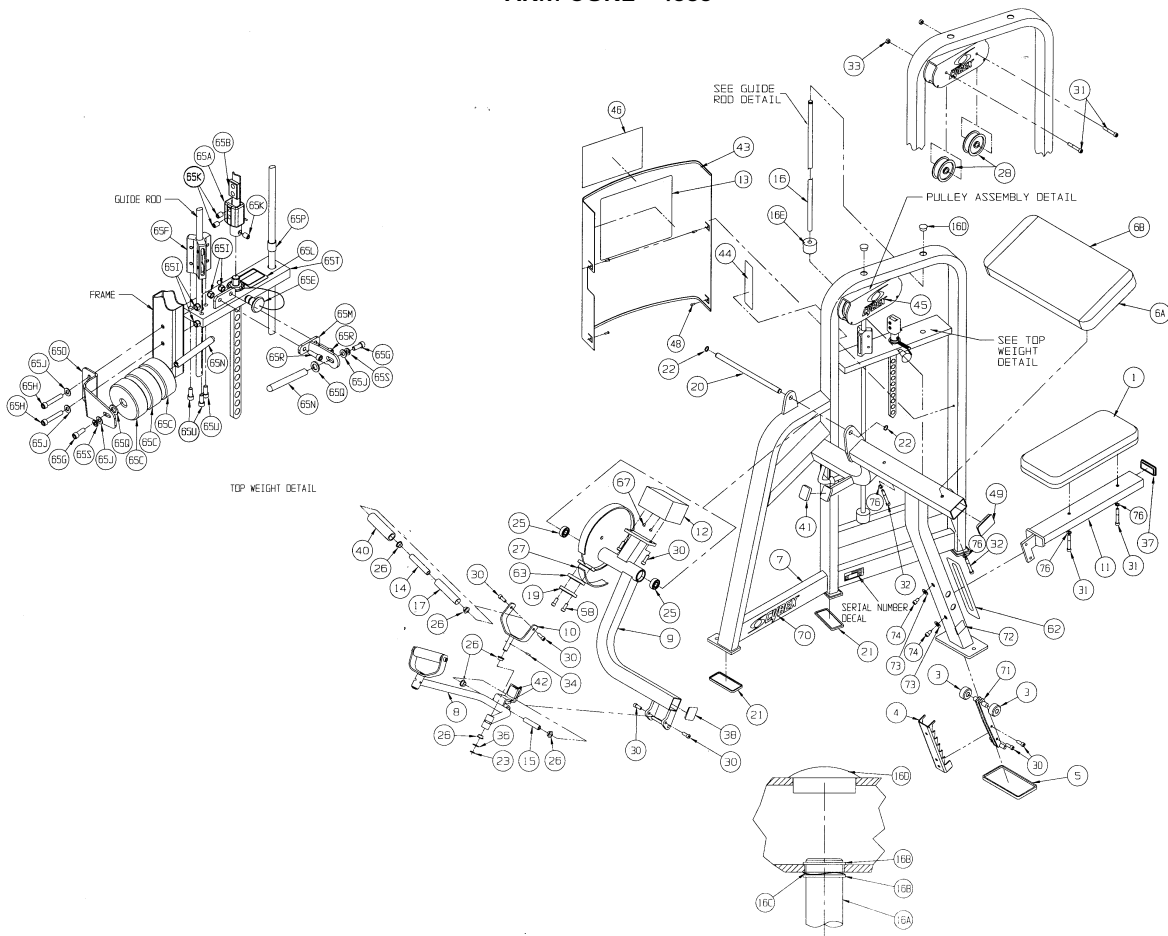

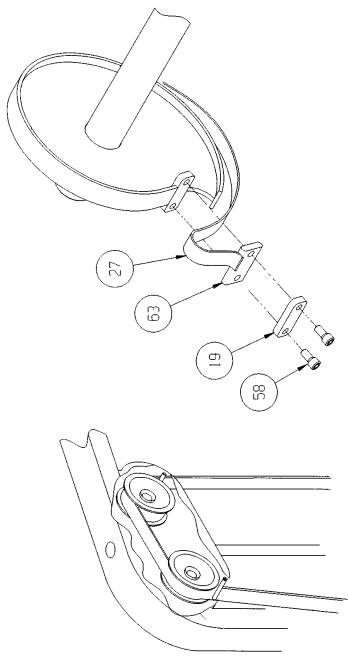

BELT ROUTING DETAILS

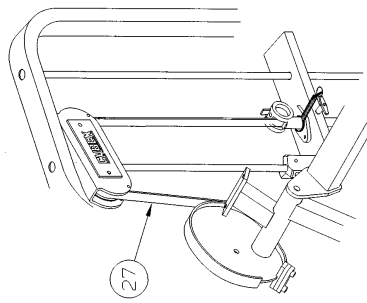

BELT ROUTING DETAIL

ARM EXTENSION

PRODUCT NO. 4540

PARTS LIST

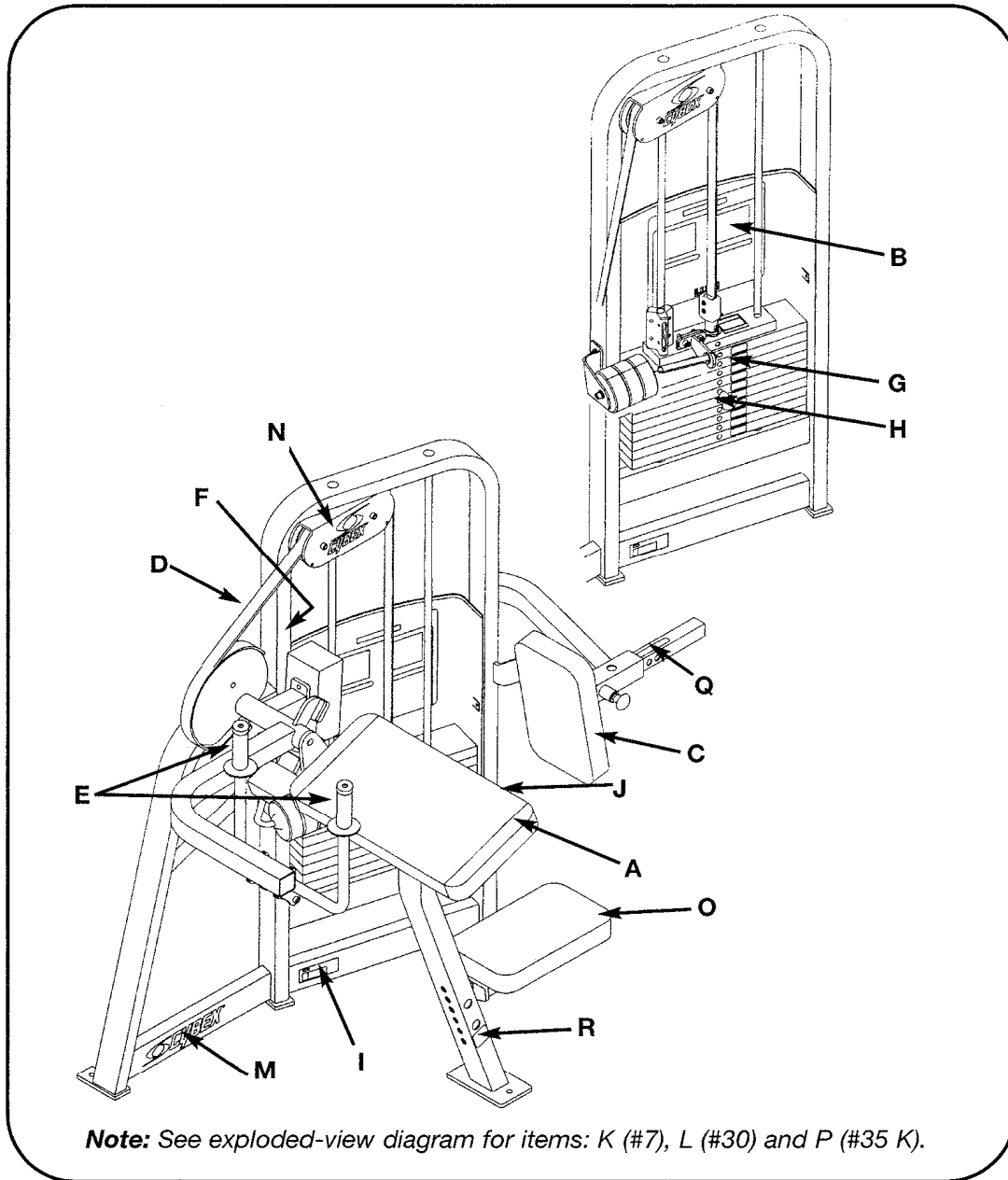

DESCRIPTION	PART NO.	DESCRIPTION	PART NO.
A. Arm Cushion w/Wear Cover.....	4800-008	K. Seat Adjustment Decal..	5221-316
B. Placard Decal.....	4540-319	L. Cybex Decal Blk/Plm	3900-391
C. Cushion.....	4800-019	L. Cybex Decal Wht/Wht...	3900-419
D. Belt.....	GB000202	M. Cybex Decal Blk/Plm	3900-390
E. Grip.....	4605-510	M. Cybex Decal Wht/Wht...	3900-415
F. Warning Decal.....	4605-381	N. Cybex Decal Blk/Plm	3900-423
G. Weight Plate Decal.....	4605-388	N. Cybex Decal Wht/Wht...	3900-424
H. Weight Selector Pin.....	BH030207	O. Cushion.....	4800-026
I. Serial Number Decal		P. Warning Decal.....	4605-424
J. Wear Cover (Item A).....	4800-091	Q. Adjusting Decal.....	4540-323
		R. Caution Decal.....	4520-362

4540 - Arm Extension

ITEM	QTY	PART NO.	DESCRIPTION	ITEM	QTY	PART NO.	DESCRIPTION
1	2	4505-331	Bumper 1.50 Dia	35 P	2	4701-001	Top Weight Guide
2	1	11040-440	Cybex Knob	35 Q	2	4700-321	Rubber Washer
3	1	4520-212	Seat Roller	35 R	2	JC702820	SHCS .375-16 x 1.25
4	2	4520-331	Roller	35 S	2	HS348300	Split Lockwasher .375
5			Removed	35 T	1	4700-239	Top Weight
6	1	PR070002	Foot Pad 4.00 x 7.00	35 U	3	HC702816	SHCS .375-16 x .875
7	1	5221-316	Adjustable Seat Decal	36			Not Used
8 A	1	4800-008	Arm Cushion/Wear Cover	37	1	4705-319	Counterweight
8 B	1	4800-091	Wear Cover	38			Not Used
9	1	4535-328	Short Pivot Pin	39			Not Used
10	1	4701-020	Weight Stack Guide Rod Set	40	2	BR030210	Retaining Ring 17 mm
10 A	2	4535-329	Weight Stack Guide Rod	41			Not Used
10 B	4	BR030214	Retaining Ring .625	42	1	BS070201	Com Spring .56 x .66 x 1.50 L
10 C	2	HS407100	Spring Washer .65 x .79 x .062 T	43			Not Used
10 D	2	PN660200	Plastic Insert 1.00 Dia x 11 G	44			Removed 8/98
10 E	2	PR060005	Weight Bumper	45	2	FB030232	Radial Brg 17 mm ID (Ext Race)
11	1	4505-431	Guard	46	2	FB130205	Flange Brg .62 x .75 x .38 L
12	1	4800-019	Cushion 10" x 12"	47	68"	GB000202	Weight Stack Belt .95" Wide
13	1	4540-200	Frame	48	2	GP000209	Pulley Assembly 3.50
14	1	4540-201	Pivot Arm	49			Not Used
15	1	4540-202	Seat	50	6	HC702817	SHCS .375-16 x 1.00
16	1	4540-205	Cushion Tube	51	4	HC702830	SHCS .375-16 x 2.50
17	1	4540-204	Handle	52	2	HC702834	SHCS .375-16 x 3.00
18	1	4605-511	Plastic Insert 5.94	53	2	HN704901	Nylon Locknut .375-16
19	1	4540-319	Placard Decal	54			Removed
20			Not Used	55			Not Used
21			Removed	56			Not Used
22	1	4605-300	Belt Clamp	57	4	HT102214	Tap Screw #10-12 x .625 A (Phil)
23	1	4605-322	Detent Pin	58			Not Used
24	1	4605-334	Pivot Shaft 13.06	59	2	JC702820	SHCS .375-16 x 1.25
25			Not Used	60			Replaced by item #51
26	3	PR070003	Foot Pad 2.00 x 5.25	61			Not Used
27	2	11090-374	End Cap	62	1	PP090202	Plastic Insert 1.50 x 3.00 x 11
28	1	4605-381	Warning Decal	63	1	PP090206	Plastic Insert
29	1	3900-423	Cybex Decal 4.85 Vert. Blk/Plm	64	1	PP090210	Plastic Insert 2.00 sq x 10-14 G
29	1	3900-424	Cybex Decal 4.85 Vert. Wht/Wht	65	1	PP090211	Plastic Insert 1.50 sq x 10-14 G
29			Removed 3/03	66			Removed
30			Removed 3/03	67	2	4605-510	Grip 4.75" long
30	1	3900-391	Cybex Decal 11.37 Vert Blk/Plm	68	2	PU060203	Bumper
30	1	3900-419	Cybex Decal 11.37 Vert. Wht/Wht	69	2	4540-321	Bumper Handle
31	1	4605-388	Weight Plate Decal 10-290	70	2	HC702822	SHCS .375-16 x 1.50
32			Not Used	71			Not Used
33	1	4605-394	Belt Clamp	72			Removed
34			Removed 8/98	73			Removed 3/03
35	1	4701-030	Sliding Increment Weight Set	73	1	3900-390	Cybex Decal 1.57 Horiz. Blk/Plm
35 A	1	11040-216	Belt Clamp	73	1	3900-415	Cybex Decal 1.57 Horiz. Wht/Wht
35 B	1	11040-301	Belt Clamp Insert	74	1	4800-026	Cushion
35 C	3	4605-390	Increment Weight	75	1	4701-302	VR2 Weight Stack Instr. (not shown)
35 D			Removed 3/03	76	2	JC702814	SHCS .375-16 x .625
35 E	1	BH030207	Weight Selector Pin	77	1	51198	Strength Warranty Sheet (not shown)
35 F	1	FB130208	Bearing Sleeve .68 x .81 1.00 L	78	2	HF449063	Tube Insert
35 G	2	HC702817	SHCS .375-16 x 1.00	79	1	4540-323	Adjusting Decal
35 H	2	HC702828	SHCS .375-16 x 2.25	80	1	4520-213	Bracket
35 I	4	HN704901	Nylon Locknut .375-16	81	1	4520-362	Caution Decal
35 J	4	HS347600	Washer, SAE .375	82	2	HS347700	Washer USS .375
35 K	1	HY740000	Set Screw	83	2	JC702812	SHCS .375-16 x .50
35 L	1	4605-424	Caution Decal	84	9	4000C101	Stack Weight 4 x 18 (not shown)
35 M	1	4700-240	Weight Mount	85	4	JS347400	Internal Tooth Lockwasher
35 N	2	4700-318	Increment Weight Rod	86	2	JC620422	BHSCS .250-20 x 1.50
35 O	1	4700-319	Frame Mount Increment Weight				

ARM EXTENSION - 4540

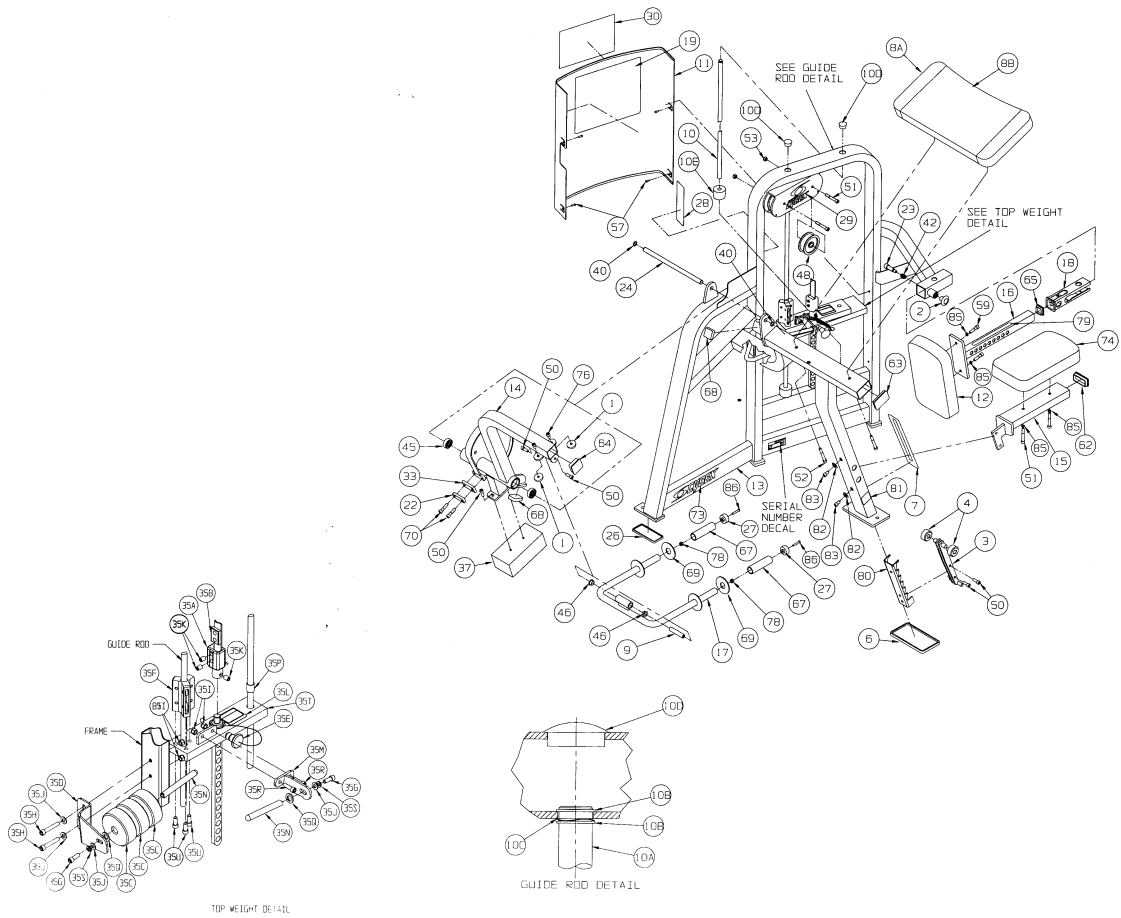

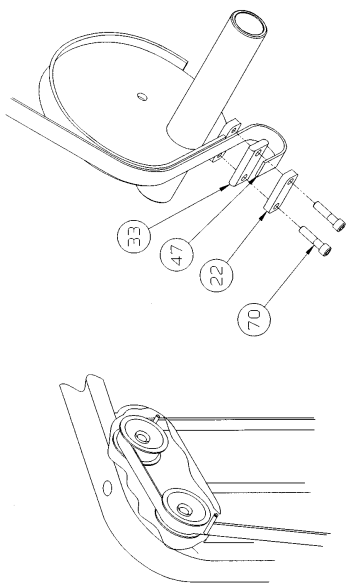

BELT ROUTING DETAIL

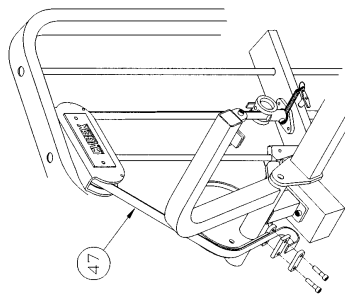

BELT ROUTING DETAIL

FLY

PRODUCT NO. 4545

PARTS LIST

Note: Item D - Weight Stack Belt = 73.0" Long
Item D - Rear Belt = 55.5" Long

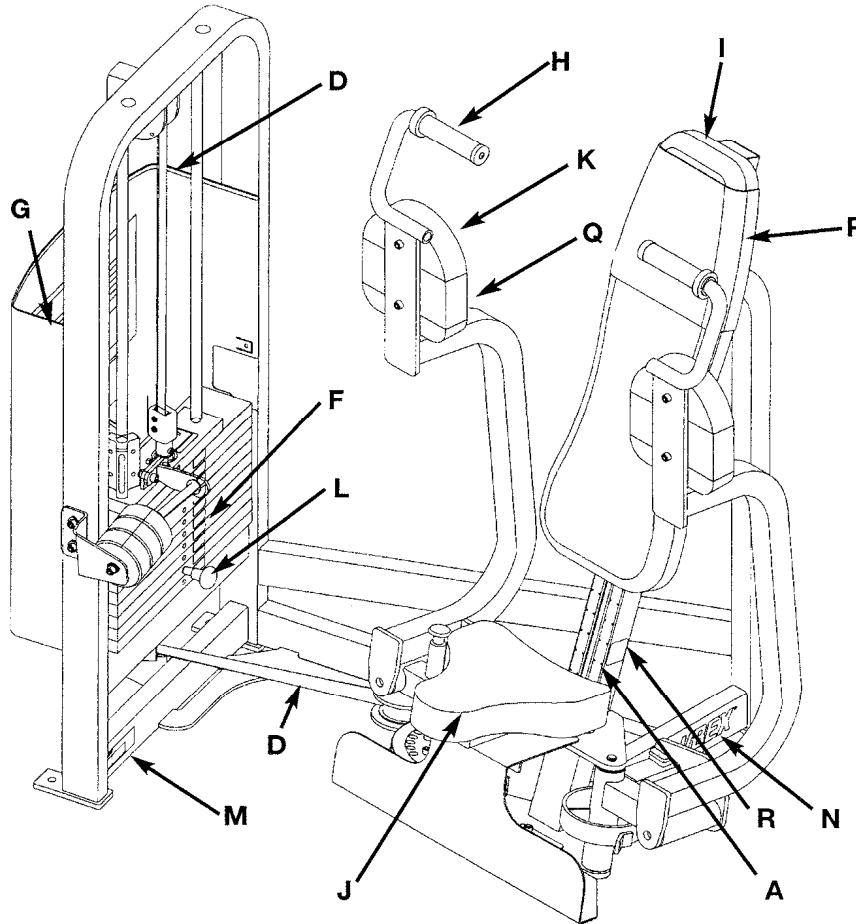

See exploded-view diagram for items:
B (#12), C (#25), E (#30), and O (#65).

DESCRIPTION	PART NO.	DESCRIPTION	PART NO.
A. Seat Adjustment Decal..	5221-316	L. Weight Selector Pin.....	BH030207
B. Cable Subassembly.....	4545-002	M. Serial Number Decal	
C. Cam Decal	4545-332	N. Cybex Decal Blk/Plm	3900-390
D. Belt .95" wide.....	GB000202	N. Cybex Decal Wht/Wht ..	3900-415
E. Warning Decal.....	4605-381	O. Cybex Decal Blk/Plm	3900-391
F. Weight Plate Decal	4605-388	O. Cybex Decal Wht/Wht ..	3900-419
G. Placard	4545-598	P. Wear Cover (Item I)	4800-106
H. Grip	4605-501	Q. Wear Cover (Item K)	4800-090
I. Back Cushion w/Wear Cover.....	4800-103	R. Caution Decal.....	4520-362
J. Seat Cushion.....	4800-026	S. Caution Decal.....	4605-424
K. Arm Cushion w/Wear Cover.....	4800-018		

4545 - Fly

ITEM	QTY	PART NO.	DESCRIPTION	ITEM	QTY	PART NO.	DESCRIPTION
1			Not Used	35 T	1	4700-239	Top Weight
2			Removed	35 U	3	HC702816	SHCS .375-16 x .875
3	1	11040-440	Cybex Knob	36	1	4701-302	VR2 Weight Stack Instr. (not shown)
4			Not Used	37	2	5220-320	Pivot Shaft 7.06
5	1	4505-207	Seat	38	8	BR030210	Retaining Ring 17mm
6	1	PR070001	Foot Pad 2.50 x 4.25	39	1	BS070201	Com Spring .56 x .66 x 1.50 L
7	1	4520-212	Seat Roller	40			Removed
8	2	4520-331	Roller	41	8	FB030232	Radial Brg17 mm ID (Ext Race)
9			Removed	42	2	FB130206	Flange Brg 2.00 x 2.25 x 1.00 L
10	1	PR070002	Foot Pad 4.00 x 7.00	43 A	73"	GB000202	Weight Stack Belt .95" Wide
11	1	5221-316	Seat Adjustment Decal	43 B	55.5"	GB000202	Input Arm Belt .95" Wide
12	2	4545-002	Cable Subassembly	44	4	GP000209	Pulley Assembly 3.50
13	1	4545-200	Frame	45	2	HC702817	SHCS .375-16 x 1.00
14	1	4545-201	Cam	46	6	HC702822	SHCS .375-16 x 1.50
15	1	4545-202	Right Hand Arm	47	6	HC702830	SHCS .375-16 x 2.50
16	1	4645-203	Left Hand Arm	48	11	HN704901	Nylon Locknut .375-16
17	1	4545-204	Left Hand Pivot	49	4	HN784000	Hex Nut .500-13
18	1	4545-205	Right Hand Pivot	50			Removed
19	1	4545-206	Plate	51	4	HT102214	Tap Screw #10-12 x .625 A (Phil)
20	1	4545-207	Connector	52	4	JC702814	SHCS .375-16 x .625
21	1	4545-316	Detent Pin	53	4	JC702824	SHCS .375-16 x 1.75
22	1	4505-435	Guard	54	2	JN714200	Hex Nut .375-24
23	1	4545-325	Kick Plate	55	2	JN714400	Jam Nut .375-24
24	2	4545-331	Pivot Shaft 9.13	56	1	PP090202	Plastic Insert 1.50 X 3.00 x 11 G
25	1	4545-332	Cam Decal	57	1	PP090206	Plastic Insert
26	1	4545-598	Placard Decal	58			Not Used
27	3	4605-300	Belt Clamp	59			Not Used
28	2	PR070003	Foot Pad 2.00 x 5.25	60	2	PR060003	Recess Bumper
29	2	11090-374	End Cap	61	2	4605-502	Grip 9.0 long
30	1	4605-381	Warning Decal	62 A	1	4800-103	Back Cushion w/Wear Cover
31			Not Used	62 B	1	4800-106	Wear Cover
32	1	4605-388	Weight Plate Decal 10-290	63	1	4800-026	Seat Cushion
33	3	4605-394	Belt Clamp	64 A	2	4800-018	Arm Cushion w/Wear Cover
34	1	4701-020	Weight Stack Guide Rod Set	64 B	2	4800-090	Wear Cover
34 A	2	4535-329	Weight Stack Guide Rod	65			Removed 3/03
34 B	4	BR030214	Retaining Ring .625	65	1	3900-391	Cybex Decal 11.37 Vert. Blk/Plm
34 C	2	HS407100	Spring Washer .65 x .79 x .062 T	65	1	3900-419	Cybex Decal 11.37 Vert. Wht/Wht
34 D	2	PN660200	Plastic Insert 1.00 Dia x 11G	66			Removed 3/03
34 E	2	PR060005	Weight Bumper	66	1	3900-390	Cybex Decal 1.57 Horiz. Blk/Plm
35	1	4701-030	Sliding Increment Weight Set	66	1	3900-415	Cybex Decal 1.57 Horiz. Wht/Wht
35 A	1	11040-216	Belt Clamp	67	6	HF449063	Connector Insert .75 x .25-20
35 B	1	11040-301	Belt Clamp Insert	68	5	4505-331	Bumper
35 C	3	4605-390	Increment Weight	69	1	51198	Strength Warranty Sheet (not shown)
35 D			Removed 3/03	70	2	HC702815	SHCS .375-16 x .750
35 E	1	BH030207	Weight Selector Pin	71	4	HC702816	SHCS .375-16 x .875
35 F	1	FB130208	Bearing Sleeve .68 x .81 1.00 L	72	3	HC702828	SHCS .375-16 x 2.25
35 G	2	HC702817	SHCS .375-16 x 1.00	73			Not Used
35 H	2	HC702828	SHCS .375-16 x 2.25	74	2	PP090213	Plastic Insert
35 I	4	HN704901	Nylon Locknut .375-16	75	*	4545-341	Shim Washer .015
35 J	4	HS347600	Washer, SAE .375	76	2	HC702834	SHCS .375-16 x 3.00
35 K	1	HY740000	Set Screw	77	2	JC702820	SHCS .375-16 x 1.25
35 L	1	4605-424	Caution Decal	78	1	4520-213	Bracket
35 M	1	4700-240	Weight Mount	79	1	4520-362	Caution Decal
35 N	2	4700-318	Increment Weight Rod	80	2	HS347700	Washer USS .375
35 O	1	4700-319	Frame Mount Increment Weight	81	2	JC702812	SHCS .375-16 x .50
35 P	2	4701-001	Top Weight Guide	82	9	4000C101	Stack Weight 4 x 18 (not shown)
35 Q	2	4700-321	Rubber Washer	83	2	11090-376	Handle Grip Ring
35 R	2	JC702820	SHCS .375-16 x 1.25	84	2	JC620422	BHSCS .250-20 x 1.50
35 S	2	HS348300	Split Lockwasher .375	85	8	JS347400	Internal Tooth Lockwasher

*Quantity will vary

FLY - 4545

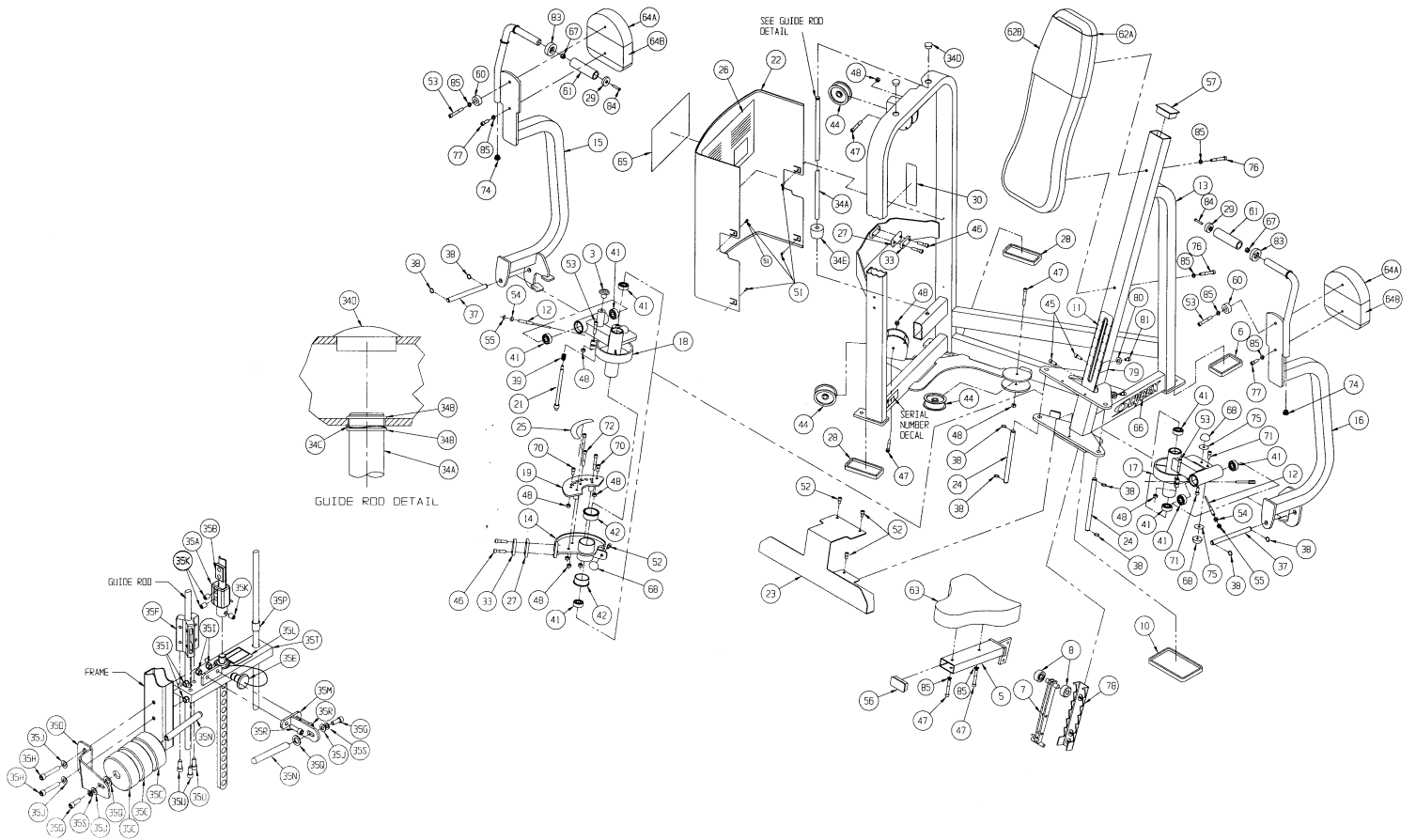

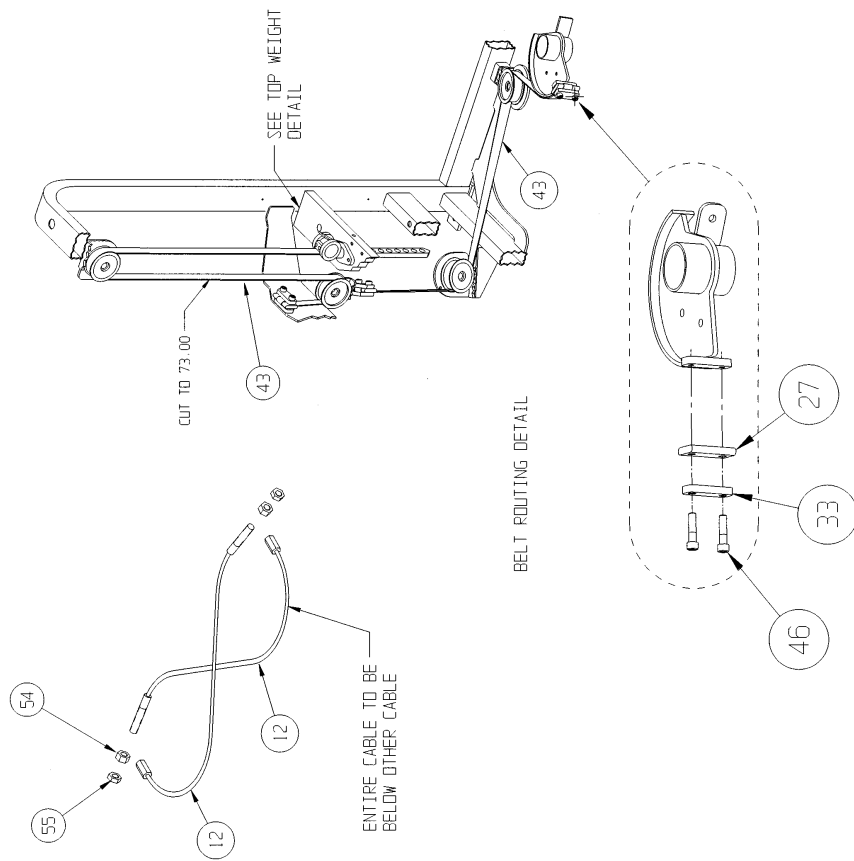

SEATED LEG PRESS

PRODUCT NO. 4605

PARTS LIST

Note: Item D - Weight Stack Belt = 108.5" Long
Item D - Rear Belt = 65" Long

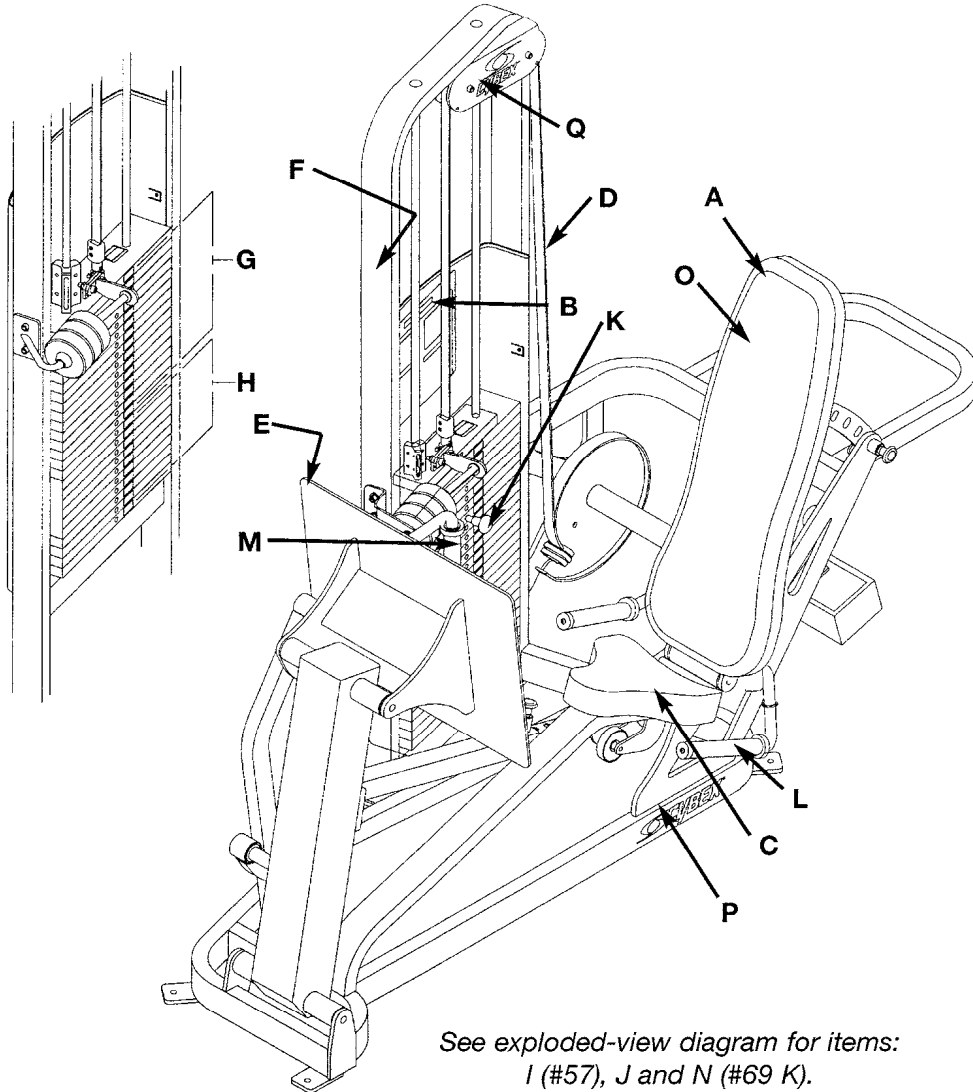

DESCRIPTION	PART NO.	DESCRIPTION	PART NO.
A. Back Cushion w/Wear Cover.....	4800-111	J. Serial Number Decal	
B. Placard Decal.....	4605-374	K. Weight Selector Pin.....	BH030207
C. Seat Cushion.....	4800-026	L. Grip.....	4605-506
D. Belt.....	GB000202	M. Grip.....	4605-509
E. Non-Slip.....	4605-372	N. Caution Decal.....	4605-424
F. Warning Decal.....	4605-381	O. Wear Cover (Item A).....	4800-114
G. Weight Plate Decal.....	4605-388	P. Cybex Decal Blk/Plm ...	3900-390
H. Weight Plate Decal.....	4605-389	P. Cybex Decal Wht/Wht ..	3900-415
I. Cybex Decal Blk/Plm ...	3900-391	Q. Cybex Decal Blk/Plm	3900-423
I. Cybex Decal Wht/Wht ..	3900-419	Q. Cybex Decal Wht/Wht ..	3900-424

4605 - Seated Leg Press

ITEM	QTY	PART NO.	DESCRIPTION	ITEM	QTY	PART NO.	DESCRIPTION
1	2	11040-440	Cybox Knob	55	1	4605-381	Warning Decal
2	1	4505-331	Bumper 1.50 Dia	56	1	3900-423	Cybox Decal 4.85 Vert. Blk/P
3	1	ZC000001	Counterweight	56	1	3900-424	Cybox Decal 4.85 Vert. Wht/vv..
4			Removed	56			Removed 3/03
5	1	4800-026	Seat Cushion	57			Removed 3/03
6 A	1	4800-111	Backrest Cushion w/Wear Cover	57	1	3900-391	Cybox Decal 11.37 Vert. Blk/Pim
6 B	1	4800-114	Wear Cover	57	1	3900-419	Cybox Decal 11.37 Vert. Wht/Wht
7	1	4605-200	Frame	58			Removed
8	1	4605-201	Linkage (Long)	59	3	4605-394	Belt Clamp
9	1	4605-202	Counterweight	60	4	HT102214	Tap Screw #10-12 x .625 A (Phil)
10	1	4605-203	Linkage (Short)	61	1	JC702814	SHCS .375-16 x .625
11	1	4605-204	Footplate	62			Removed
12	1	4605-205	Pivot Bracket	63			Removed
13	1	4605-206	Cushion Support	64			Not Used
14	1	4605-207	Guard	65			Not Used
15	1	4605-216	Adjusting Tube (Inner)	66	1	4605-388	Weight Plate Decal 10-290
16	1	4605-217	Adjusting Tube (Outer)	67	1	4605-389	Weight Plate Decal 310-490
17	1	4605-211	Cam	68			Not Used
18			Removed	69	1	4701-033	Sliding Increment Weight Set
19	3	4605-300	Belt Clamp	69 A	1	11040-216	Belt Clamp
20	2	4605-322	Detent Pin	69 B	1	11040-301	Belt Clamp Insert
21	1	4701-024	Weight Stack Guide Rod Set	69 C	3	4605-390	Increment Weight
21 A	2	4605-323	Weight Stack Guide Rod	69 D			Removed 3/03
21 B	4	BR030214	Retaining Ring .625	69 E	1	BH030207	Weight Selector Pin
21 C	2	HS407100	Spring Washer .65 x .79 x .062 T	69 F	1	FB130208	Bearing Sleeve .68 x .81 1.00 L
21 D	2	PN660200	Plastic Insert 1.00 Dia x 11G	69 G	4	HC702817	SHCS .375-16 x 1.00
21 E	2	PR060005	Weight Bumper	69 H	2	HC702828	SHCS .375-16 x 2.25
22	1	4605-327	Adjusting Arm	69 I	4	HN704901	Nylon Locknut .375-16
23	1	4605-333	Pivot Shaft 26.25	69 J	4	HS347600	Washer, SAE .375
24	2	4605-334	Pivot Shaft 13.06	69 K	1	HY740000	Set Screw .375-16 x .25 Cup Pt
25	2	4605-512	Plastic Insert 7.94	69 L	1	4605-424	Caution Decal
26	2	PR070003	Foot Pad 2.00 x 5.25	69 M	1	4700-240	Weight Mount
27	3	11090-374	End Cap	69 N	2	4700-318	Increment Weight Rod
28	1	4605-372	Non-Slip	69 O	1	4700-319	Frame Mount Increment Weig
29	1	4605-373	Pivot Shaft 4.06	69 P	2	4701-001	Top Weight Guide
30	1	4605-374	Placard Decal	69 Q	2	4700-321	Rubber Washer
31	1	5220-305	Bumper 2.00 x 4.00	69 R	2	JC702820	SHCS .375-16 x 1.25
32	2	5220-320	Pivot Shaft 7.06	69 S	2	HS348300	Split Lockwasher .375
33	16	BR030210	Retaining Ring 17 mm	69 T	1	4700-238	Top Weight
34	4	BR030212	Retaining Ring 1.575 Internal	69 U	3	HC702816	SHCS .375-16 x .875
35			Not Used	70			Removed
36	2	BS070201	Com Spring .56 x .66 x 1.50 L	71			Not Used
37			Not Used	72			Not Used
38	1	GP000210	Pulley Assembly 3.00 Idler	73			Not Used
39	14	FB030232	Radial Brg 17 mm ID (Ext Race)	74			Not Used
40	2	FB130207	Flange Brg 17 mm x 19 mm x 25 mm	75	6	HC702822	SHCS .375-16 x 1.50
41 A	108.5"	GB000202	Weight Stack Belt .95" Wide	76			Not Used
41 B	65"	GB000202	Rear Belt .95" Wide	77			Not Used
42	4	GP000209	Pulley Assembly 3.50	78	1	HC702826	SHCS .375-16 x 2.00
43	3	HC702815	SHCS .375-16 x .750	79	1	4701-302	VR2 Weight Stack Instr (not shown)
44			Removed	80	1	51198	Strength Warranty Sheet (not shown)
45	6	HC702817	SHCS .375-16 x 1.00	81	3	HF449063	Tube Insert
46	8	HC702830	SHCS .375-16 x 2.50	82	3	PP080207	Plastic Insert
47	6	HN704901	Nylon Locknut .375-16	83			Removed 3/03
48	1	HP266717	Spiral Pin .125 x 1.00	83	1	3900-390	Cybox Decal 1.57 Horiz. Blk/Pim
49			Not Used	83	1	3900-415	Cybox Decal 1.57 Horiz. Wht/Wht
50	4	PP090208	Plastic Insert 1.75 Dia	84	1	4605-427	Adjusting Decal
51 A	2	4605-506	Grip 8.0" Long	85	14	4000C101	Stack Weight 4 x 18 (not shown)
51 B	1	4605-509	Grip 4.0" Long	86	3	11090-376	Handle Grip Ring
52	3	PR070001	Foot Pad 2.50 x 4.25	87	3	JC620422	BHSCS .250-20 x 1.50
53			Removed 8/98	88	4	JS347400	Internal Tooth Lockwasher
54	1	4505-434	Guard				

SEATED LEG PRESS - 4605

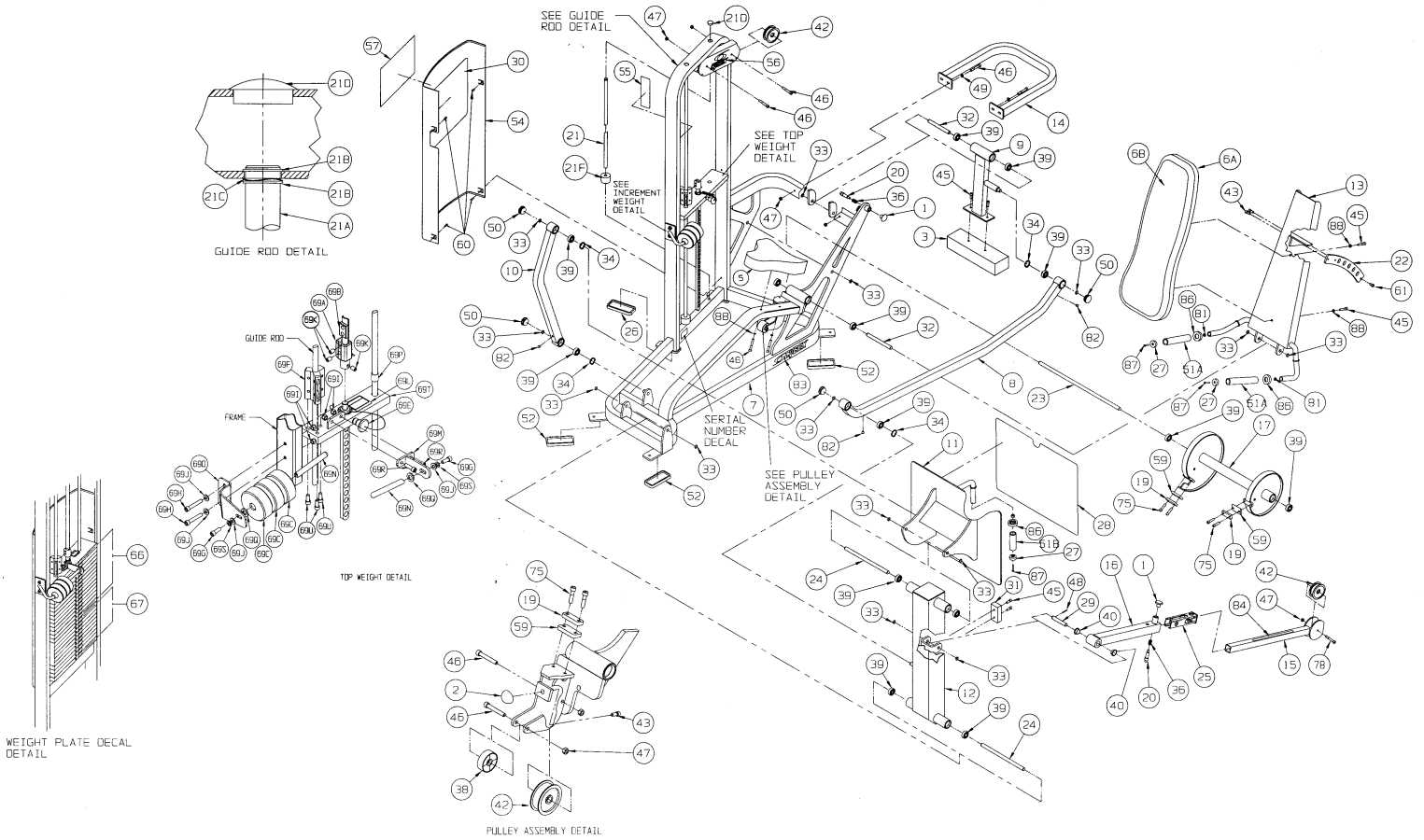

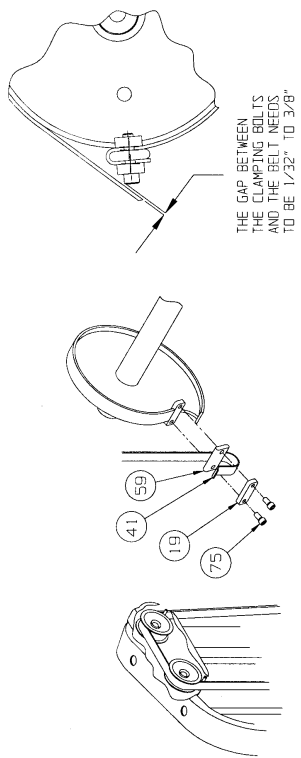

BELT ROUTING DETAIL

BELT CLAMPING DETAIL

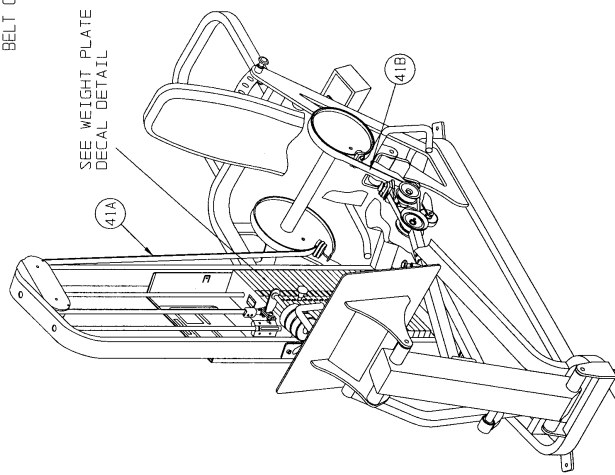

BELT ROUTING DETAIL

LEG EXTENSION

PRODUCT NO. 4611, 4612, 4613

PARTS LIST

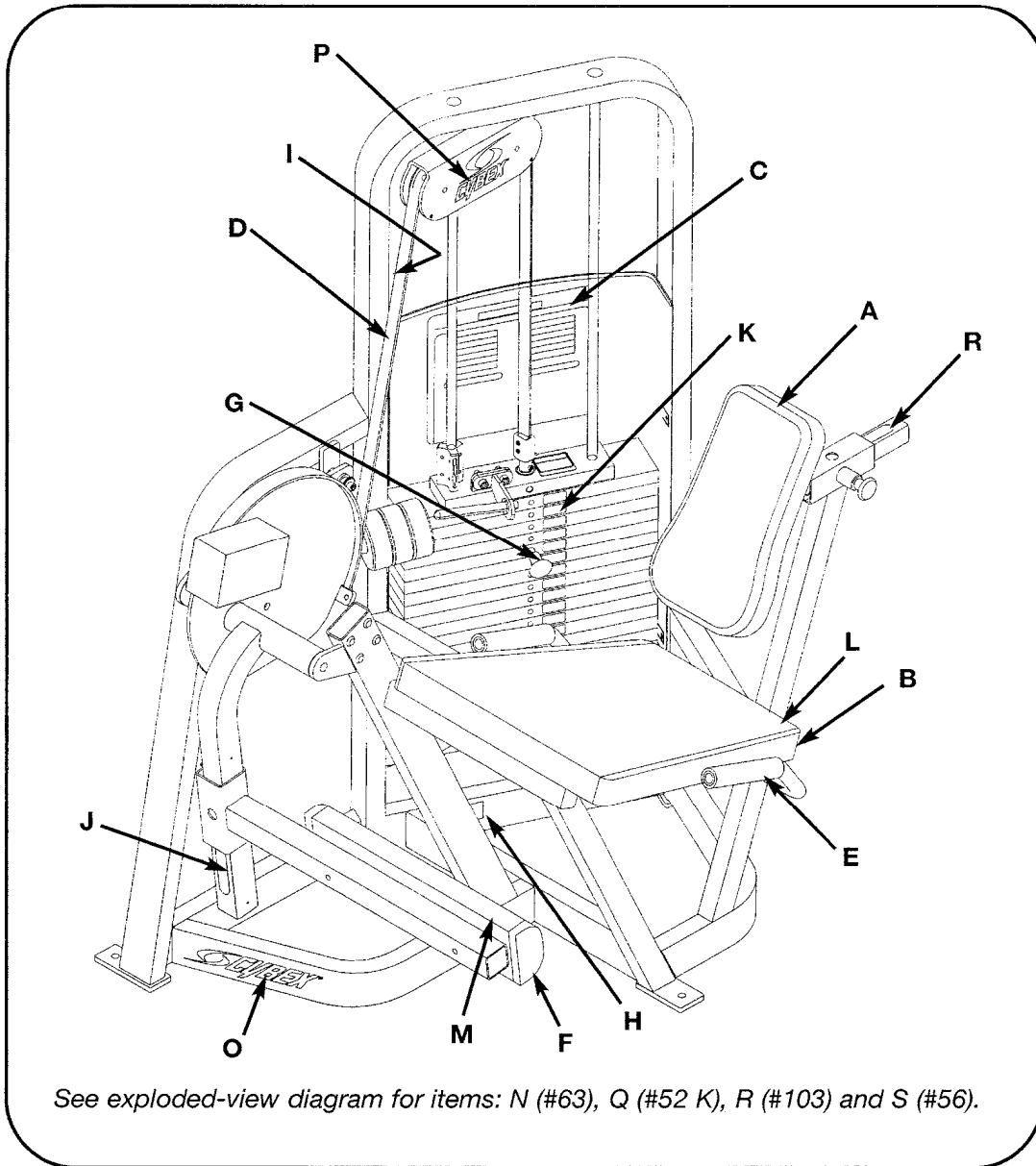

DESCRIPTION	PART NO.	DESCRIPTION	PART NO.
A. Back Cushion.....	4800-115	K. Weight Plate Decal.....	4605-388
B. Seat Cushion w/Wear Cover	4800-012	L. Wear Cover (item B)	4106S079-0
C. Placard	4610-320	M. Wear Cover (item F)	4800-093
D. Belt	GB000202	N. Cybex Decal Blk/Plm	3900-391
E. Grip	4605-507	N. Cybex Decal Wht/Wht ..	3900-419
F. Leg Bar Cushion w/Wear Cover.....	4800-006	O. Cybex Decal Blk/Plm ...	3900-390
G. Weight Selector Pin	BH030207	O. Cybex Decal Wht/Wht ..	3900-415
H. Serial Number Decal		P. Cybex Decal Blk/Plm ...	3900-423
I. Warning Decal.....	4605-381	P. Cybex Decal Wht/Wht ..	3900-424
J. Adjusting Decal	4855-317	Q. Caution Decal	4605-424
		R. Adjusting Decal	4850-314
		S. Grip	4605-515

4611, 4612, 4613 - Leg Extension

ITEM	QTY	PART NO.	DESCRIPTION	ITEM	QTY	PART NO.	DESCRIPTION
1	1	01692	Threaded Insert	52 N	2	4700-318	Increment Weight Rod
2	1	01694	Corner Bracket	52 O	1	4700-319	Frame Mount Increment Weight
3	1	11060-002	Handle Subassembly	52 P	1	FB130208	Bearing Sleeve .68 x .81 1.00 L
4	1	11040-440	Cybex Knob	52 Q	2	4700-321	Rubber Washer
5	1	4701-021	Weight Stack Guide Rod Set	52 R	2	JC702820	SHCS .375-16 x 1.25
5 A	2	4505-319	Weight Stack Guide Rod	52 S	2	HS348300	Split Lockwasher .375
5 B	4	BR030214	Retaining Ring .625	52 T	1	4700-238	Top Weight
5 C	2	HS407100	Spring Washer .65 x .79 x .062 T	52 U	3	HC702816	SHCS .375-16 x .875
5 D	2	PN660200	Plastic Insert 1.00 Dia x 11 G	53	1	4701-201	Lifting Post 15
5 E	2	PR060005	Weight Bumper	54	1	51119	Selector Pin Retainer
6	1	PR070001	Foot Pad 2.50 x 4.25	55	1	BH030201	Quick Release Pin
7	1	4800-115	Back Cushion	56	1	4605-515	Grip 3.25" Long
8	1	4535-324	Counterweight	57	2	HS407100	Spring Washer .65 x .79 x .062 T
9			Removed	58	2	JC702814	SHCS .375-16 x .625
10	1	4605-300	Belt Clamp	59	2	PN660200	Plastic Insert
11	1	4605-322	Detent Pin	60	1	4505-432	Guard
12	1	4605-334	Pivot Shaft 13.06	61	1	4605-381	Warning Decal
13	3	PR070003	Foot Pad 2.00 x 5.25	62			Removed 3/03
14	2	11090-374	End Cap	62	1	3900-390	Cybex Decal 1.57 Horiz. Blk/Plm
15 A	1	4800-012	Seat Cushion w/Wear Cover	62	1	3900-415	Cybex Decal 1.57 Horiz. Wht/Wht
15 B	1	4106S079-0	Wear Cover	63			Removed 3/03
16	1	4611-200	Frame	63	1	3900-391	Cybex Decal 11.37 Vert. Blk/Plm
17	1	4613-208	Cam	63	1	3900-419	Cybex Decal 11.37 Vert. Wht/Wht
18	1	4611-207	Cushion Tube	64	1	4605-394	Belt Clamp
19	1	4610-203	Handle (Right Hand)	65			Removed 5/99
20	1	4610-204	Handle (Left Hand)	66			Not Used
21	1	4610-320	Placard Decal	67	4	HT102214	Tap Screw #10-12 x .625 A (Phil)
22	1	4605-511	Plastic Insert	68			Removed 8/98
23 A	1	4800-006	Leg Bar Cushion w/Wear Cover	69	2	PP080221	Black Insert .375 Dia
23 B	1	4800-093	Wear Cover	70	1	4611-206	Stop Bar
24	1	4611-204	Leg Bar	71	8	PP660006	Snap In Plug
25	2	BR030210	Retaining Ring 17 mm	72	3	PR740300	Center Bonded Mount
26			Not Used	73	3	HC702828	SHCS .375-16 x 2.25
27	3	BS070201	Com Spring .56 x .66 x 1.50 L	74			Not Used
28	2	PR060005	Weight Bumper	75	3	HS347700	Washer .375 USS
29	2	FB030232	Radial Brg 17 mm ID (Ext Race)	76	1	4505-329	Detent Pin
30	76"	GB000202	Belt .95" Wide	77	1	4612-596	RDL Start Decal
31	2	GP000209	Pulley Assembly 3.50	78			Removed
32	5	HC702816	SHCS .375-16 x .875	79	1	4613-203	Cam Arm
33	5	HC702822	SHCS .375-16 x 1.50	80	1	4613-302	Short Pivot Pin
34	6	HC702830	SHCS .375-16 x 2.50	81	1	4613-304	Plate
35	6	HC702834	SHCS .375-16 x 3.00	82	1	4613-326	Bar Stop
36	2	HD303318	Bolt .250 X .250 x .190/10-24	83	1	4613-327	Input Cam Decal
37	9	HN704901	Nylon Locknut .375-16	84	1	FB030239	Cam Follower 10 mm
38			Not Used	85	2	FB130205	Flange Brg .62 x .75 x .38 L
39	5	JC702820	SHCS .375-16 x 1.25	86	4	PP080222	Vinyl End Cap .50 x .50
40	1	PP090000	Plastic Insert 1.5 x 2.0 -11 G	87	1	4613-328	Cam Stop Decal
41	1	PP090202	Plastic Insert 1.5 x 3.0 -11 G	88	1	4613-331	Cam Plate
42	2	PP090210	Plastic Insert 2.00 sq x 10-14 G	89	1	4613-320	Detent Pin
43	1	PP090211	Plastic Insert 1.50 sq x 10-14 G	90	1	4613-202	Start Stop
44			Removed	91	1	4613-594	Total RLD Decal
45	1	4605-507	Grip 6.5" Long	92	2	4715-336	Washer
46	1	PU060203	Bumper	93	2	BR030213	External Retaining Ring 2.00
47	1	PU060211	Bumper .62 sq x .25	94	2	FB130206	Flange Brg 2.00 x 2.75 x 1.50 L
48			Not Used	95	1	4613-206	Detent Plate
49			Not Used	96	1	4611-333	Tube
50	1	4605-388	Weight Plate Decal 10-290	97	2	PP080202	Plastic Insert 1.19 Dia X 11 G
51			Not Used	98			Not Used
52	1	4701-031	Sliding Increment Weight Set	99	1	4701-302	VR2 Weight Stack Instr. (not shown)
52 A	1	11040-216	Belt Clamp	100	1	51198	Strength Warranty Sheet (not shown)
52 B	1	11040-301	Belt Clamp Insert	101	2	HF449063	Tube Insert
52 C	3	4605-390	Increment Weight	102	1	3900-423	Cybex Decal 4.85 Vert. Blk/Plm
52 D			Removed 3/03	102	1	3900-424	Cybex Decal 4.85 Vert. Wht/Wht
52 E	1	BH030207	Weight Selector Pin	102			Removed 3/03
52 F	1	4701-001	Top Weight Guide	103	1	4850-314	Adjusting Decal
52 G	2	HC702817	SHCS .375-16 x 1.00	104	1	4855-317	Adjusting Decal
52 H	2	HC702828	SHCS .375-16 x 2.25	105	14	4000C101	Stack Weight 4 x 18 (not shown)
52 I	4	HN704901	Nylon Locknut .375-16	106	2	11090-376	Handle Grip Ring
52 J	4	HS347600	Washer, SAE .375	107	2	JC620422	BHSCS .250-20 x 1.50
52 K	3	HY740000	Set Screw	108	6	JS347400	Internal Tooth Lockwasher
52 L	1	4605-424	Caution Decal	109	1	4611-208	Cam
52 M	1	4700-240	Weight Mount				

LEG EXTENSION - 4611, 4612, 4613

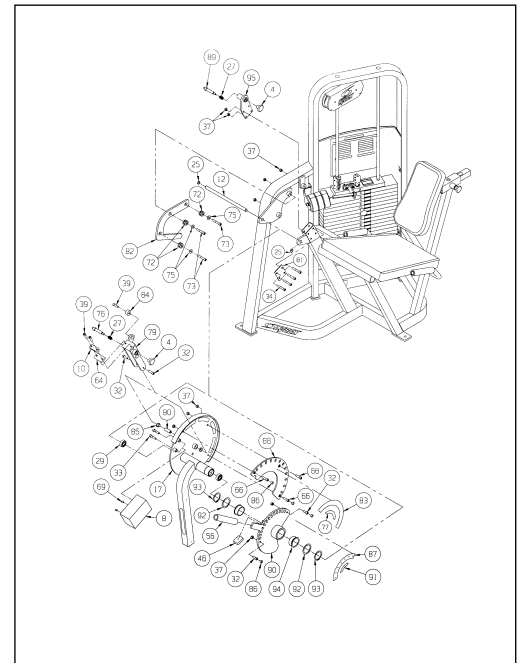
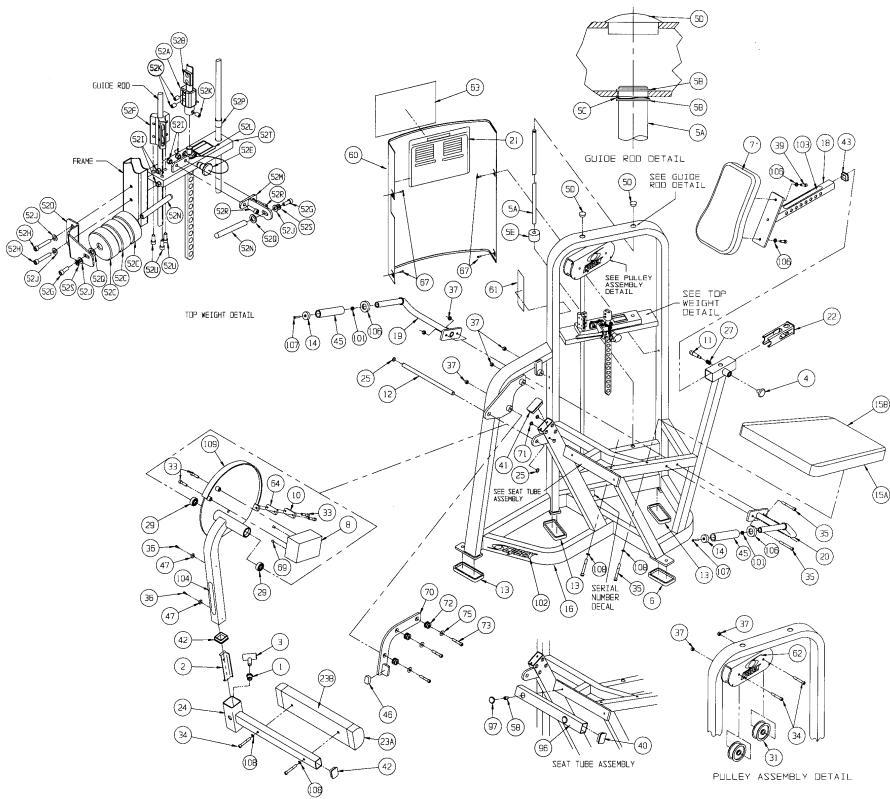

4613 - Leg Extension Total RLD

PRONE LEG CURL

PRODUCT NO. 4616, 4617, 4618

PARTS LIST

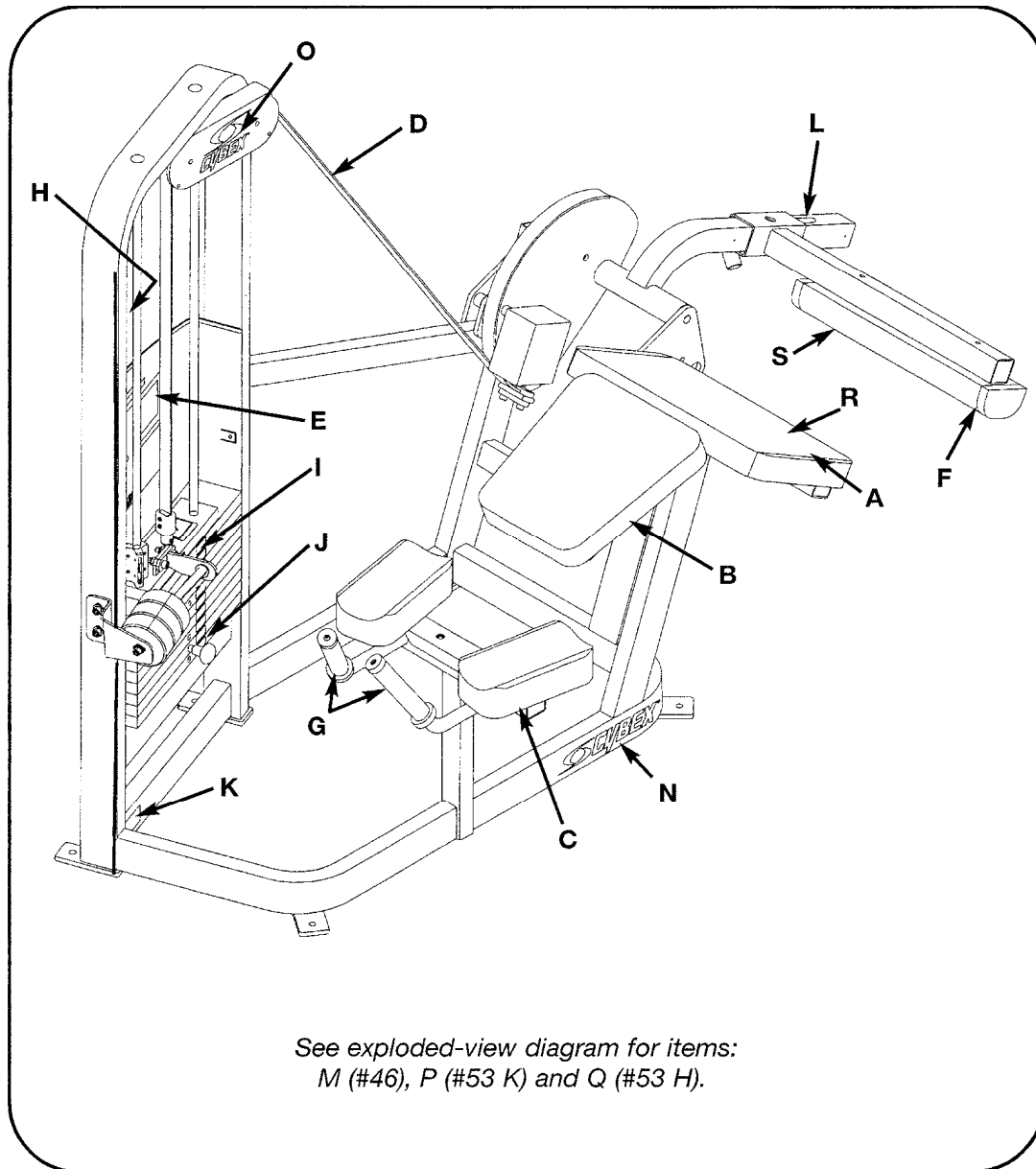

See exploded-view diagram for items:
M (#46), P (#53 K) and Q (#53 H).

DESCRIPTION	PART NO.	DESCRIPTION	PART NO.
A. Thigh Cushion w/Wear Cover.....	4800-029	K. Serial Number Decal	
B. Chest Cushion	5245-011	L. Adjusting Decal	4855-317
C. Elbow Cushion	4800-017	M. Cybex Decal Blk/Plm	3900-391
D. Belt	GB000202	M. Cybex Decal Wht/Wht ..	3900-419
E. Placard Decal	4615-322	N. Cybex Decal Blk/Plm	3900-390
F. Leg Bar Cushion w/Wear Cover	4800-006	N. Cybex Decal Wht/Wht ..	3900-415
G. Grip.....	4605-500	O. Cybex Decal Blk/Plm	3900-423
H. Warning Decal	4605-381	O. Cybex Decal Wht/Wht ..	3900-424
I. Weight Plate Decal	4605-388	P. Grip.....	4605-515
J. Weight Selector Pin.....	BH030207	Q. Caution Decal	4605-424
		R. Wear Cover (item A)	4800-098
		S. Wear Cover (item F)	4800-093

4616, 4617, 4618 - Prone Leg Curl

ITEM	QTY	PART NO.	DESCRIPTION
1	1	01692	Threaded Insert
2	1	01694	Corner Bracket
3	1	11060-002	Handle Subassembly
4	1	4701-021	Weight Stack Guide Rod Set
4 A	2	4505-319	Weight Stack Guide Rod
4 B	4	BR030214	Retaining Ring .625
4 C	2	HS407100	Spring Washer .65 x .79 x .062 T
4 D	2	PN660200	Plastic Insert 1.00 Dia x 11 G
4 E	2	PR060005	Weight Bumper
5	2	PR070001	Foot Pad 2.50 x 4.25
6	1	4616-307	Counterweight
7	1	4605-213	Top Weight Increment Rod
8	1	4605-300	Belt Clamp
9	1	4605-334	Pivot Shaft 13.06
10	3	PR070003	Foot Pad 2.00 x 5.25
11	2	11090-374	End Cap
12 A	1	4800-029	Thigh Cushion w/Wear Cover
12 B	1	4800-098	Wear Cover
13	1	5245-011	Chest Cushion
14	2	4800-017	Elbow Cushion
15 A	1	4800-006	Leg Bar Cushion w/Wear Cover
15 B	1	4800-093	Wear Cover
16	1	4616-200	Frame
17	1	4616-203	Cam
18	1	4616-201	Leg Bar
19	1	4615-203	Handle Bar
20	1	4615-322	Placard Decal
21	1	4615-323	Machined Bumper
22	2	BR030210	Retaining Ring 17 mm
23			Not Used
24	2	PR060005	Weight Bumper
25	2	FB030232	Radial Brg 17 mm ID (Ext Race)
26	99"	GB000202	Belt .95" Wide
27	2	GP000209	Pulley Assembly 3.50
28	9	HC702816	SHCS .375-16 x .875
29	6	HC702830	SHCS .375-16 x 2.50
30	4	HC702834	SHCS .375-16 x 2.25
31	2	HD303318	Shldr Bolt .25 x .25 x .190/10-24
32	16	HN704901	Nylon Locknut .375-16
33			Not Used
34	11	JC702820	SHCS .75-16 x 1.25
35	3	PP090000	Plastic Insert 1.5 x 2.0 x 11 G
36	1	PP090202	Plastic Insert 1.5 x 3.0 x 11 G
37	4	PP090210	Plastic Insert.2.00 Sq x 10-14 G
38			Removed 3/03
39			Removed
40	2	4605-500	Grip 6" Long
41	1	4616-309	Stop Plate
42	2	PU060211	Bumper .62 x .62 x .25
43	1	4505-431	Guard
44	1	4605-381	Warning Decal
45	1	3900-423	Cybox Decal 4.85 Vert. Blk/Plm
45	1	3900-424	Cybox Decal 4.85 Vert. Wht/Wht
45			Removed 3/03
46			Removed 3/03
46	1	3900-391	Cybox Decal 11.37 Vert. Blk/Plm
46	1	3900-419	Cybox Decal 11.37 Vert. Wht/Wht
47	4	HT102214	Tap Screw #10-12 X .625 A (Phil)
48			Removed 8/98
49			Not Used
50			Not Used
51	1	4605-388	Weight Plate Decal (10-290)
52			Not Used
53	1	4701-030	Sliding Increment Weight Set
53 A	1	11040-216	Belt Clamp
53 B	1	11040-301	Belt Clamp Insert
53 C	3	4605-390	Increment Weight

ITEM	QTY	PART NO.	DESCRIPTION
53 D			Removed 3/03
53 E	1	BH030207	Weight Selector Pin
53 F	1	4701-001	Top Weight Guide
53 G	2	HC702817	SHCS .375-16 x 1.00
53 H	2	HC702828	SHCS .375-16 x 2.25
53 I	4	HN704901	Nylon Locknut .375-16
53 J	4	HS347600	Washer, SAE .375
53 K	3	HY740000	Set Screw
53 L	1	4605-424	Caution Decal
53 M	1	4700-240	Weight Mount
53 N	2	4700-318	Increment Weight Rod
53 O	1	4700-319	Frame Mount Increment Weight
53 P	1	FB130208	Bearing Sleeve .68 x .81 1.00 L
53 Q	2	4700-321	Rubber Washer
53 R	2	JC702820	SHCS .375-16 x 1.25
53 S	2	HS348300	Split Lockwasher .375
53 T	1	4700-239	Top Weight
53 U	3	HC702816	SHCS .375-16 x .875
54			Not Used
55			Not Used
56	4	HC702822	SHCS .375-16 x 1.50
57			Not Used
58			Not Used
59			Not Used
60	1	4605-394	Belt Clamp
61			Removed 5/99
62			Not Used
63			Removed
64	3	HC702828	SHCS .375-16 x 2.25
65	1	PU060201	Bumper
66	3	PR740300	Center Bonded Mount
67	3	HS347700	Washer .375 USS
68	1	11040-440	Knob
69	1	4505-329	Detent Pin
70	1	4612-596	Start RLD Decal
71	1	4613-302	Short Pivot Pin
72	4	PP080222	Vinyl End Cap .50 x .50
73	1	4618-206	Cam
74	1	FB030239	Cam Follower
75	2	FB130205	Flange Brg .62 x .75 x .38 L
76	1	4618-205	Cam Arm
77	1	4618-305	Barstop
78	1	4628-334	Input Cam Decal
79	1	4628-336	Cam Plate
80	2	BS070201	Com Spring .56 x .66 x 1.5 L
81	1	4613-320	Detent Pin
82	1	4618-304	Cam Stop Decal
83	2	4715-336	Washer
84	2	BR030213	Retaining Ring 2.00
85	2	FB130206	Flange Brg 2.00 x 2.25 x 1.00 L
86	1	PU060203	Bumper
87	1	4618-202	Stop Cam
88	1	4605-515	Grip 3.25 Long
89	1	4618-203	Detent Plate
90	1	4613-594	Total RLD Decal
91			Removed 3/03
91	1	3900-390	Cybox Decal 1.57 Horiz. Blk/Plm
91	1	3900-415	Cybox Decal 1.57 Horiz. Wht/Wht
92	1	4701-302	VR2 Weight Stack Instr. (not shown)
93	1	51198	Strength Warranty Sheet (not shown)
94	2	HF449063	Tube Insert
95	1	4855-317	Adjusting Decal
96	9	4000C101	Stack Weight 4 x 18 (not shown)
97	2	11090-376	Handle Grip Ring
98	2	JC620422	BHSCS .250-20 x 1.50
99	10	JS347400	Internal Tooth Lockwasher

PRONE LEG CURL - 4616, 4617, 4618

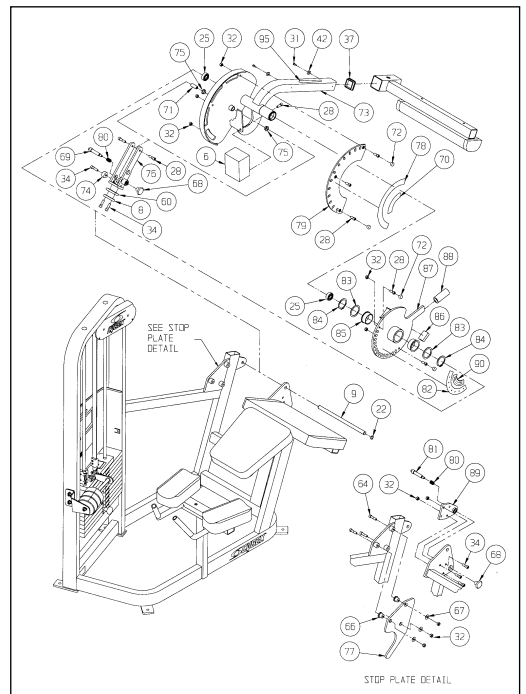
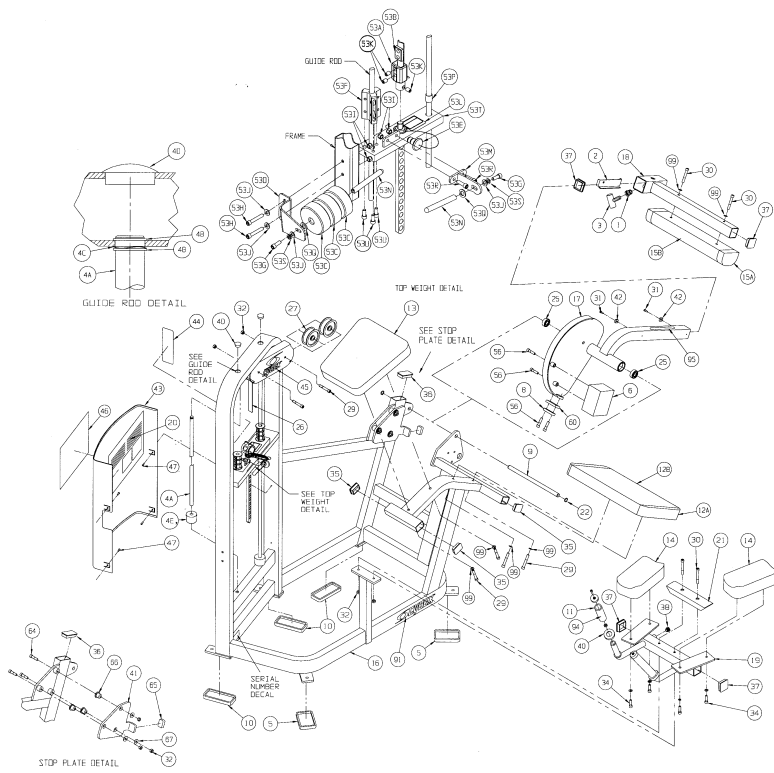

4618 - Prone Leg Curl Total RLD

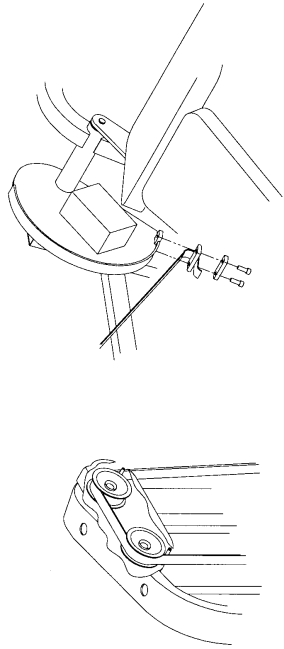

BELT ROUTING DETAIL

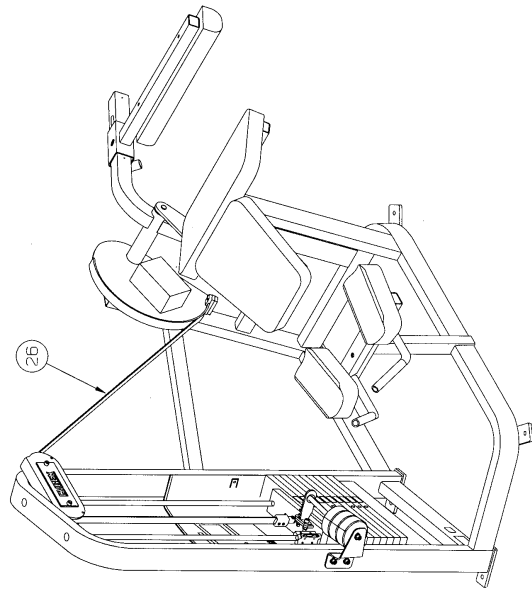

BELT ROUTING DETAIL

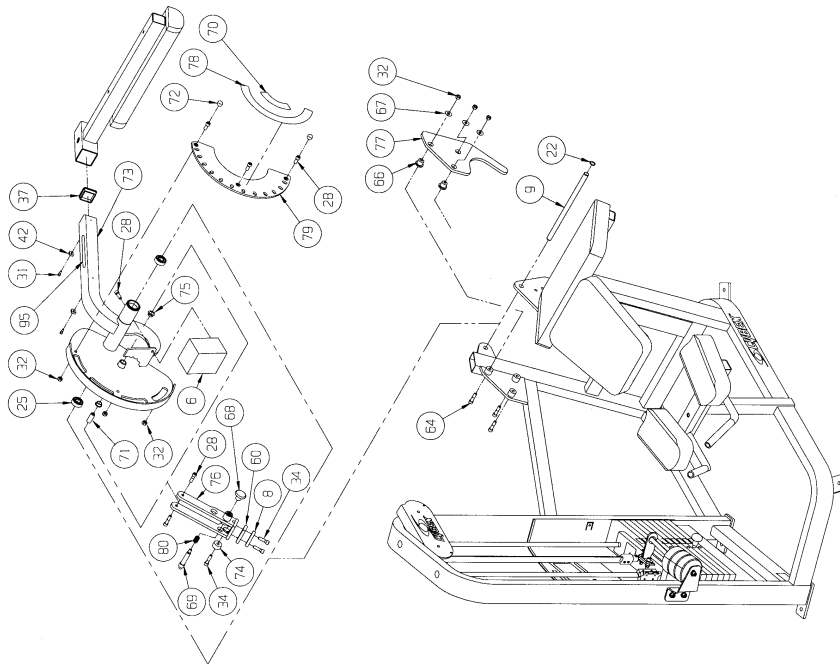

4617 - Prone Leg Curl Start RLD

ROTARY CALF

PRODUCT NO. 4620

PARTS LIST

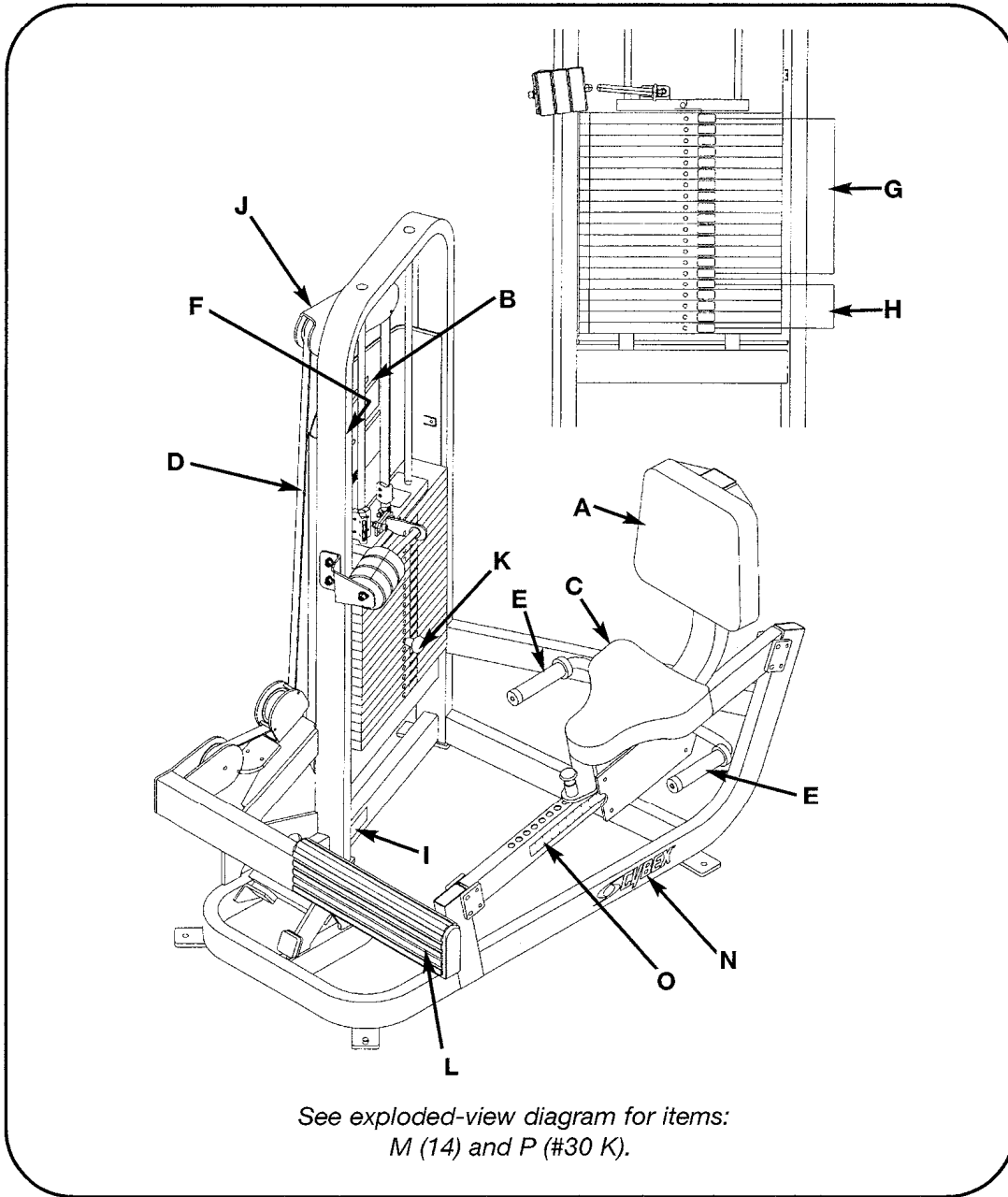

DESCRIPTION	PART NO.	DESCRIPTION	PART NO.
A. Back Cushion.....	5245-011	J. Cybex Decal Wht/Wht ..	3900-424
B. Placard Decal.....	4620-329	K. Weight Selector Pin.....	BH030207
C. Seat Cushion.....	4800-025	L. Non-Slip	4620-322
D. Belt	GB000202	M. Cybex Decal Blk/Plm	3900-391
E. Grip	4605-508	M. Cybex Decal Wht/Wht ..	3900-419
F. Warning Decal	4605-381	N. Cybex Decal Blk/Plm	3900-390
G. Weight Plate Decal	4605-388	N. Cybex Decal Wht/Wht...	3900-415
H. Weight Plate Decal	4605-389	O. Seat Adjustment Decal..	4620-331
I. Serial Number Decal		P. Warning Decal	4605-424
J. Cybex Decal Blk/Plm	3900-423		

4620 - Rotary Calf

ITEM	QTY	PART NO.	DESCRIPTION	ITEM	QTY	PART NO.	DESCRIPTION
1	1	11040-440	Cybex Knob	30 P	2	4701-001	Top Weight Guide
2	1	4701-021	Weight Stack Guide Rod Set	30 Q	2	4700-321	Rubber Washer
2 A	2	4505-319	Weight Stack Guide Rod	30 R	2	JC702820	SHCS .375-16 x 1.25
2 B	4	BR030214	Retaining Ring .625	30 S	2	HS348300	Split Lockwasher .375
2 C	2	HS407100	Spring Washer .65 x .79 x .062 T	30 T	1	4700-237	Top Weight
2 D	2	PN660200	Plastic Insert 1.00 Dia x 11G	30 U	3	HC702816	SHCS .375-16 x .875
2 E	2	PR060005	Weight Bumper	31			Removed
3	3	PR070001	Foot Pad 2.50 x 4.25	32	4	JC702836	SHCS .375-16 x 3.25
4	1	4800-025	Seat Cushion	33	1	4705-319	Counterweight
5			Not Used	34			Not Used
6			Removed	35			Not Used
7	1	4605-322	Detent Pin	36	2	BR030210	Retaining Ring 17 mm
8	1	4605-334	Pivot Shaft 13.06	37			Not Used
9			Not Used	38	1	BS070201	Com Spring .56 x .66 x 1.50 L
10	2	PR070003	Foot Pad 2.00 x 5.25	39			Not Used
11	2	11090-374	End Cap	40			Removed 8/98
12	1	4605-381	Warning Decal	41	2	FB030232	Radial Brg 17 mm ID (Ext Race)
13	2	PU060204	Bumper	42	103"	GB000202	Belt .95" Wide
14			Removed 3/03	43	4	GP000209	Pulley Assembly 3.50
14	1	3900-391	Cybex Decal 11.37 Vert. Blk/Plm	44			Removed
14	1	3900-419	Cybex Decal 11.37 Vert. Wht/Wht	45	4	HC702817	SHCS .375-16 x 1.00
15	1	4605-388	Weight Plate Decal 10-290	46			Removed 8/98
16	1	4605-389	Weight Plate Decal 310-490	47	12	HC702830	SHCS .375-16 x 2.50
17			Not Used	48	2	HC702834	SHCS .375-16 x 3.00
18	1	5245-011	Back Cushion	49	16	HN704901	Nylon Locknut .375-16
19	1	4620-200	Frame	50			Not Used
20	1	4620-201	Input Arm	51			Not Used
21	1	4620-202	Seat	52	4	HT102214	Tap Screw #10-12 x .625 A (Phil)
22	4	4620-317	Plate	53			Not Used
23	4	4620-318	Roller	54	1	4620-331	Seat Adjustment Decal
24	4	4620-319	Spacer	55			Not Used
25	1	4620-321	Adjusting Tube	56	2	PP090202	Plastic Insert 1.5 x 3.00 -11 G
26	1	4620-322	Non-Slip	57	1	PP090206	Plastic Insert
27	1	4620-329	Placard Decal	58			Removed
28	1	4620-336	Belt Bracket	59	2	4605-508	Grip 5.5" Long
29	1	4505-433	Guard	60	2	JC702820	SHCS .375-16 x 1.25
30	1	4701-032	Sliding Increment Weight Set	61			Not Used
30 A	1	11040-216	Belt Clamp	62	1	3900-423	Cybex Decal 4.85 Vert. Blk/Plm
30 B	1	11040-301	Belt Clamp Insert	62	1	3900-424	Cybex Decal 4.85 Vert. Wht/Wht
30 C	3	4605-390	Increment Weight	62			Removed 3/03
30 D			Removed 3/03	63			Removed 3/03
30 E	1	BH030207	Weight Selector Pin	63	1	3900-390	Cybex Decal 1.57 Hori. Blk/Plm
30 F	1	FB130208	Bearing Sleeve .68 x .81 1.00 L	63	1	3900-415	Cybex Decal 1.57 Hori. Wht/Wht
30 G	2	HC702817	SHCS .375-16 x 1.00	64	1	4701-302	VR2 Weight Stack Instr (not shown)
30 H	2	HC702828	SHCS .375-16 x 2.25	65			Not Used
30 I	4	HN704901	Nylon Locknut .375-16	66	2	HF449063	Tube Insert
30 J	4	HS347600	Washer, SAE .375	67	1	51198	Strength Warranty Sheet (not shown)
30 K	1	HY740000	Set Screw	68	10	4000C101	Stack Weight 4 x 18 (not shown)
30 L	1	4605-424	Caution Decal	69	2	11090-376	Handle Grip Ring
30 M	1	4700-240	Weight Mount	70	2	JC620422	BHSCS .250-20 x 1.50
30 N	2	4700-318	Increment Weight Rod	71	4	JS347400	Internal Tooth Lockwasher
30 O	1	4700-319	Frame Mount Increment Weight				

ROTARY CALF - 4620

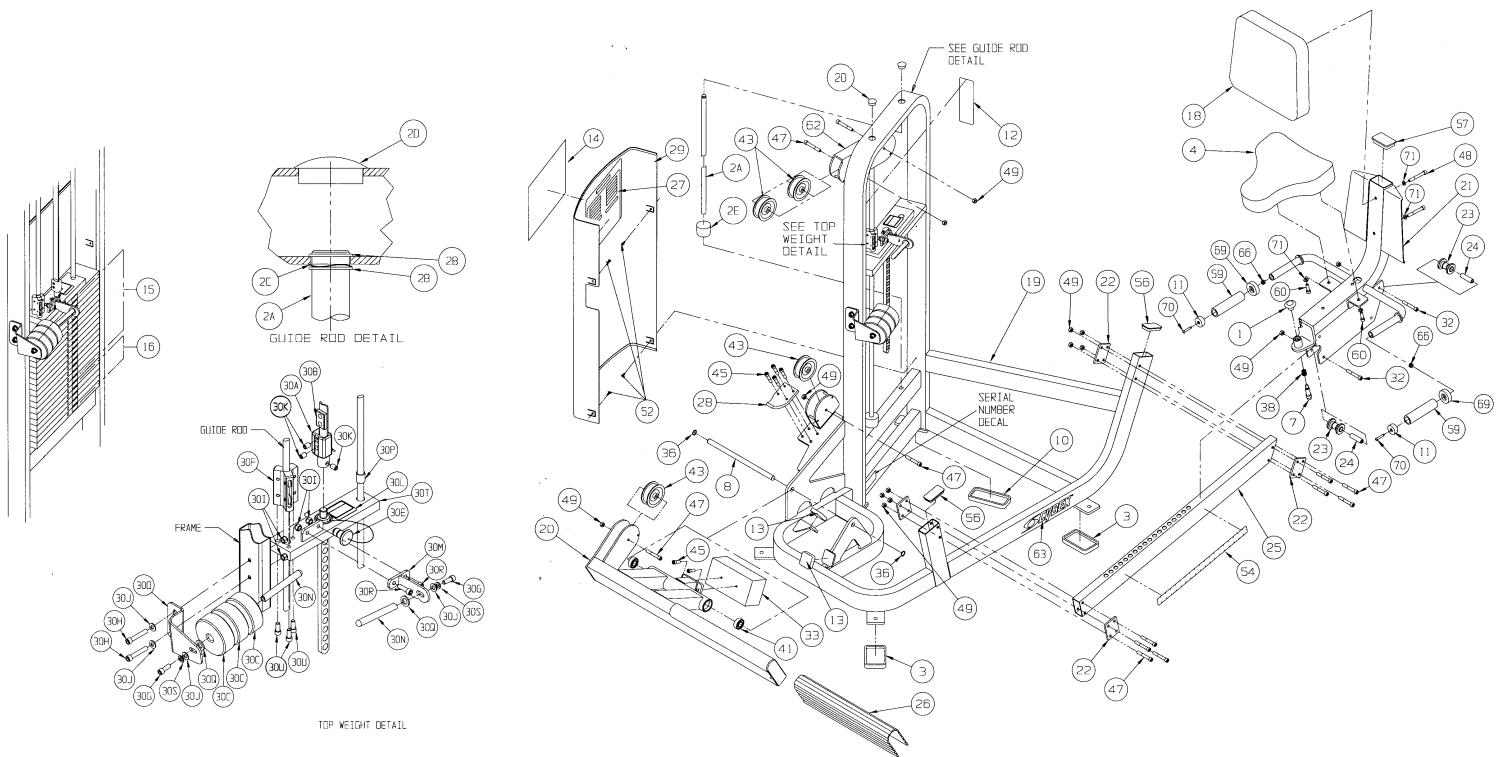

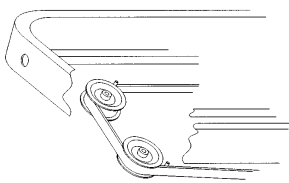

BELT ROUTING DETAIL

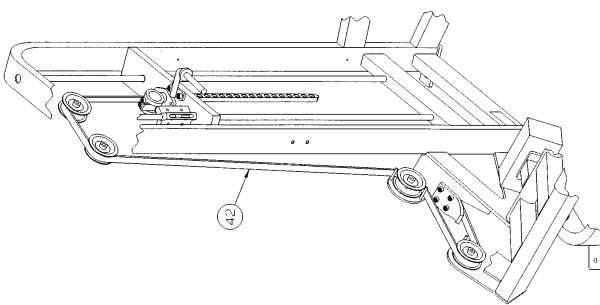

BELT ROUTING DETAIL

SEATED LEG CURL

PRODUCT NO. 4626, 4627, 4628

PARTS LIST

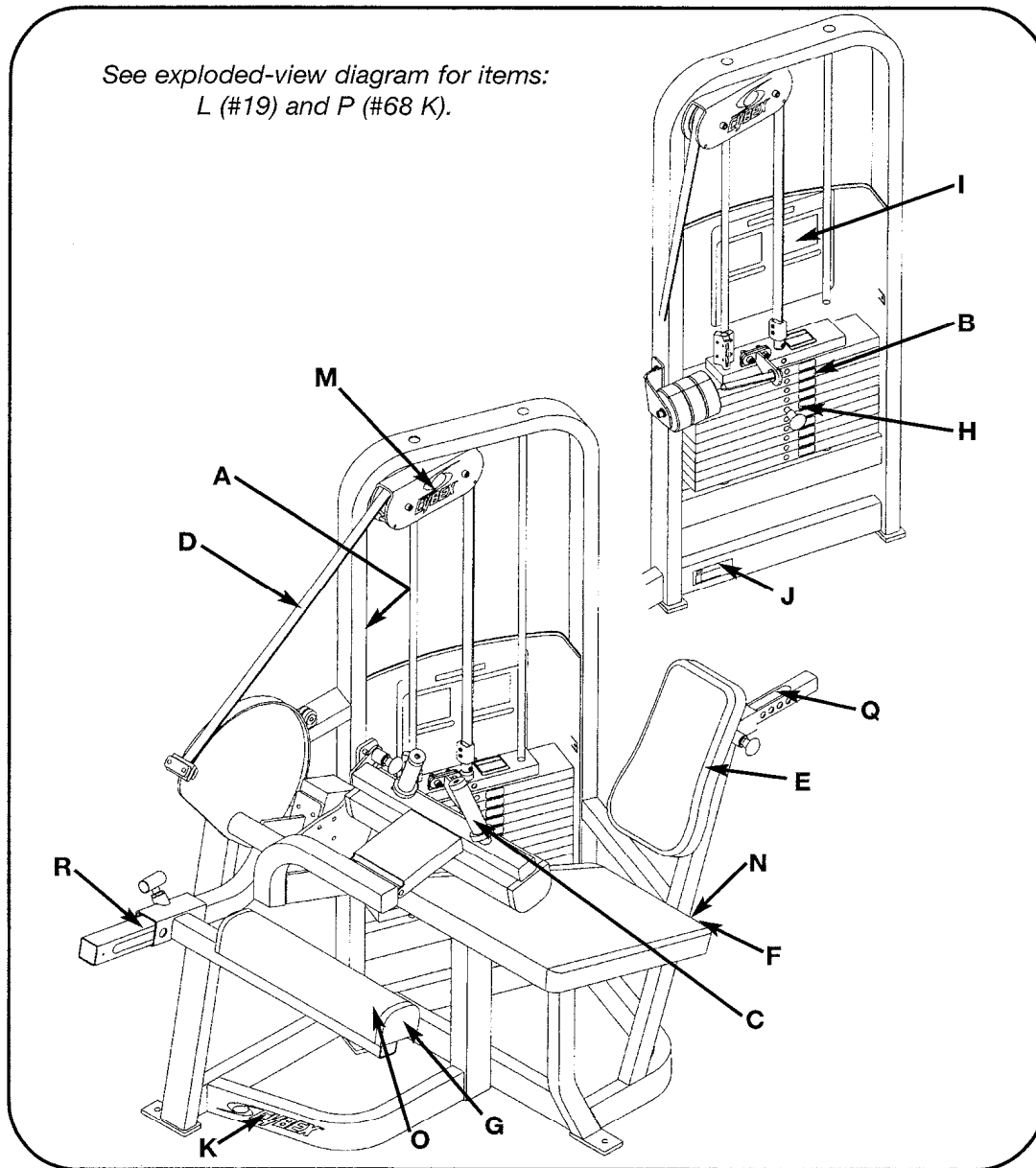

DESCRIPTION	PART NO.	DESCRIPTION	PART NO.
A. Warning Decal	4605-381	K. Cybex Decal Blk/Plm	3900-390
B. Weight Plate Decal	4605-388	K. Cybex Decal Wht/Wht...	3900-415
C. Grip 4.5" Long	4506-514	L. Cybex Decal Blk/Plm	3900-391
D. Belt	GB000202	L. Cybex Decal Wht/Wht...	3900-419
E. Back Cushion	4800-115	M. Cybex Decal Blk/Plm	3900-423
F. Seat Cushion w/Wear Cover	4800-012	M. Cybex Decal Wht/Wht...	3900-424
G. Leg Bar Cushion w/WearCover	4800-006	N. Wear Cover (Item F)	4106S079-0
H. Weight Selector Pin	BH030207	O. Wear Cover (Item G)	4800-093
I. Placard Decal	4626-598	P. Caution Decal	4605-424
J. Serial Number Decal		Q. Adjusting Decal	4805-314
		R. Adjusting Decal	4855-317
		S. Grip	4605-515

4626, 4627, 4628 - Seated Leg Curl

ITEM	QTY	PART NO.	DESCRIPTION	ITEM	QTY	PART NO.	DESCRIPTION
1	1	01112	Counterweight	61			Not Used
2	1	01692	Threaded Insert	62	1	4613-302	Short Pivot Pin
3	1	01694	Corner Bracket	63	2	PR060005	Weight Bumper
4	1	11060-002	Handle Subassembly	64			Not Used
5	2	08009	Flange Brg .50 x .62 x .50 L	65			Removed
6	2	08010	Retaining Ring .50	66			Not Used
7	4	11040-440	Cybex Knob	67			Not Used
8	1	08227	Pin .50 x 6.56	68	1	4701-030	Sliding Increment Weight Set
9	2	4505-329	Detent Pin	68 A	1	11040-216	Belt Clamp
10	1	PR070001	Foot Pad 2.50 x 4.25	68 B	1	11040-301	Belt Clamp Insert
11	1	4505-431	Guard	68 C	3	4605-390	Increment Weight
12	1	4605-300	Belt Clamp	68 D			Removed 3/03
13	1	4605-322	Detent Pin	68 E	1	BH030207	Weight Selector Pin
14	1	4605-334	Pivot Shaft 13.06	68 F	1	4701-001	Top Weight Guide
15	3	PR070003	Foot Pad 2.00 x 5.25	68 G	2	HC702817	SHCS .375-16 x 1.00
16	2	11090-374	End Cap	68 H	2	HC702828	SHCS .375-16 x 2.25
17	1	4605-381	Warning Decal	68 I	4	HN704901	Nylon Locknut .375-16
18	1	3900-423	Cybex Decal 4.85 Vert. Blk/Plm	68 J	4	HS347600	Washer, SAE .375
18	1	3900-424	Cybex Decal 4.85 Vert. Wht/Wht	68 K	3	HY740000	Set Screw
18			Removed 3/03	68 L	1	4605-424	Caution Decal
19			Removed 3/03	68 M	1	4700-240	Weight Mount
19	1	3900-391	Cybex Decal 11.37 Vert. Blk/Plm	68 N	2	4700-318	Increment Weight Rod
19	1	3900-419	Cybex Decal 11.37 Vert. Wht/Wht	68 O	1	4700-319	Frame Mount Increment Weight
20	1	4605-388	Weight Plate Decal 10-290	68 P	1	FB130208	Bearing Sleeve .68 x .81 1.00 L
21	1	4605-394	Belt Clamp	68 Q	2	4700-321	Rubber Washer
22	1	4605-511	Plastic Insert	68 R	2	JC702820	SHCS .375-16 x 1.25
23	1	4626-200	Frame	68 S	2	HS348300	Split Lockwasher .375
24	1	4626-201	Leg Bar	68 T	1	4700-239	Top Weight
25	1	4626-204	Cam	68 U	3	HC702816	SHCS .375-16 x .875
26	1	4626-203	Cushion Pivot	69			Removed
27	1	4626-322	Stop Plate	70			Not Used
28	1	4626-326	Bumper	71			Not Used
29	1	4626-598	Placard Decal	72	7	HC702816	SHCS .375-16 x .875
30	2	BR030210	Retaining Ring 17 mm	73			Not Used
31	4	BS070201	Com Spring .56 x .66 x 1.50 L	74	1	PU060203	Bumper
32	2	FB030232	Radial Brg 17 mm ID	75			Not Used
33	79"	GB000202	Belt .95" Wide	76			Not Used
34	2	GP000209	Pulley Assembly 3.50	77			Removed
35	1	HC702817	SHCS .375-16 x 1.00	78	1	4611-207	Cushion Tube
36	5	HC702822	SHCS .375-16 x 1.50	79	1	4628-206	Cam
37	2	HD303318	S/Bolt .25 x .25 x .190/10-24	80	1	4628-202	Cam Arm
38	14	HN704901	Nylon Locknut .375-16	81	1	4628-303	Bar Stop
39	7	PP080222	Vinyl Cap .50 x .50	82	1	4628-334	Input Cam Decal
40	3	HS347700	Washer .375 USS	83			Removed
41	4	HT102214	Tap Screw #10-12 x .625 A (Phil)	84	1	FM030239	Cam Follower 10 mm
42			Removed 8/98	85	2	FB130205	Flange Brg .62 x .75 x .38 L
43	1	4612-596	Start RDL Decal	86	1	4628-336	Cam Plate
44	3	PN660200	Plastic Insert 1.00 Dia x 11 G	87	1	4613-594	Total RLD Decal
45	2	PP080214	Plastic Cap .343 ID x .50	88	1	4628-203	Detent Plate
46	1	PP090000	Plastic Insert 1.50 x 2.00 x 11 G	89	1	4628-204	Cam Stop
47	3	PP090210	Plastic Insert 2.00 Sq x 10-14 G	90	1	4628-312	Detent Pin
48	2	PP090211	Plastic Insert 1.50 Sq x 10-14 G	91	1	4628-333	Cam Stop Decal
49	2	4605-514	Grip 4.50" Long	92	2	4715-336	Washer
50	3	PR740300	Center Bonded Mount	93	2	BR030213	Retaining Ring External 2.00
51	1	PU060201	Bumper	94	2	FB130206	Flange Brg 2.00 x 2.25 x 1.50 L
52	2	PU060211	Bumper	95	1	4605-515	Grip 3.25" Long
53	1	4800-115	Back Cushion	96	1	4626-331	Tube
54 A	1	4800-012	Seat Cushion w/Wear Cover	97	2	JC702814	SHCS .375-16 x .625
54 B	1	4106S079-0	Wear Cover	98			Removed 3/03
55 A	2	4800-006	Leg Bar Cushion w/Wear Cover	98	1	3900-390	Cybex Decal 1.57 Horiz. Blk/Plm
55 B	2	4800-093	Wear Cover	98	1	3900-415	Cybex Decal 1.57 Horiz. Wht/Wht
56	6	HC702830	SHCS .375-16 x 2.50	99	1	4701-302	VR2 Weight Stack Instr. (not shown)
57	2	HC702834	SHCS .375-16 x 3.00	100	1	51198	Strength Warranty Sheet (not shown)
58	9	JC702820	SHCS .375-16 x 1.25	101	2	HF449063	Tube Insert
59	1	4701-021	Weight Stack Guide Rod Set	102	1	4850-314	Adjusting Decal
59 A	2	4505-319	Weight Stack Guide Rod	103	1	4855-317	Adjusting Decal
59 B	4	BR030214	Retaining Ring .625	104	9	4000C101	Stack Weight 4 X 18 (not shown)
59 C	2	HS407100	Spring Washer .65 x .79 x .062 T	105	2	11090-376	Handle Grip Ring
59 D	2	PN660200	Plastic Insert 1.00 Dia x 11 G	106	2	JC620422	BHSCS .250-20 x 1.50
59 E	2	PR060005	Weight Bumper	107	6	JS347400	Internal Tooth Lockwasher
60			Not Used				

SEATED LEG CURL - 4626, 4627, 4628

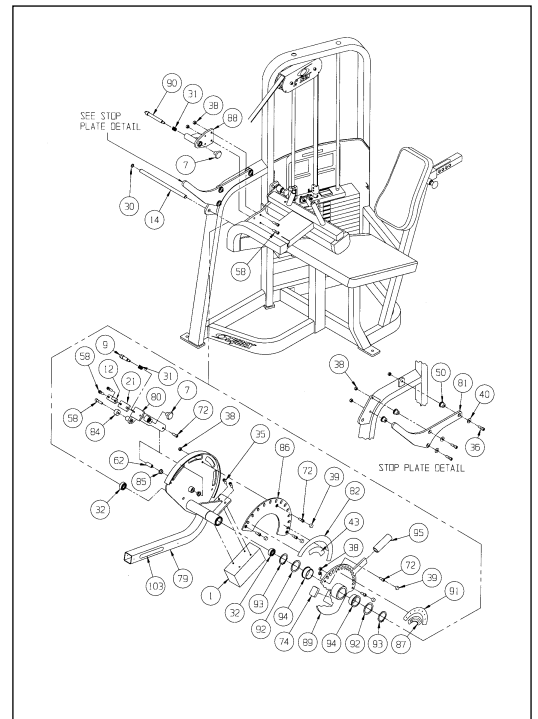
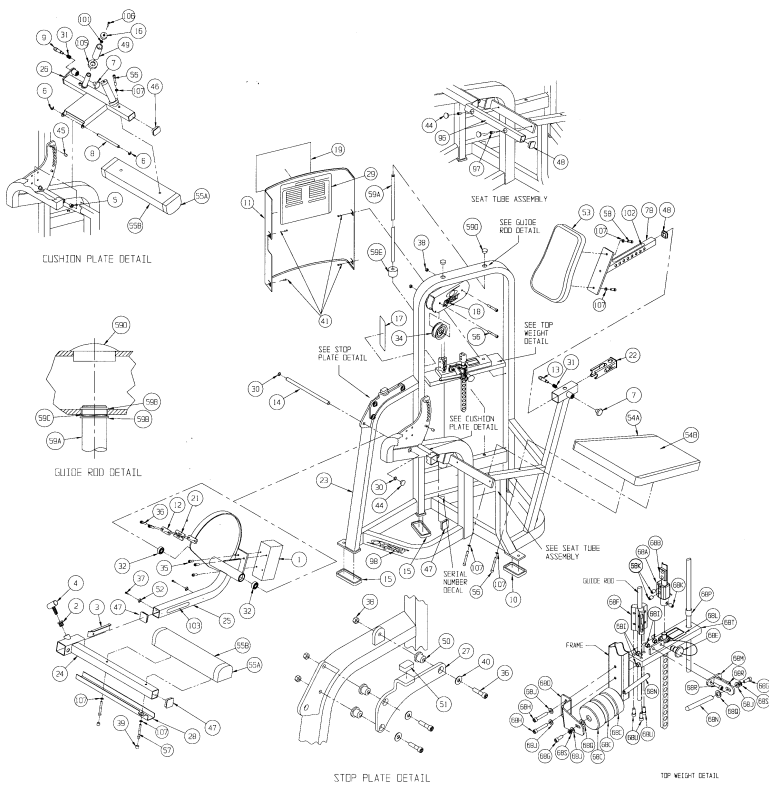

4628 - Seated Leg Curl Total RLD

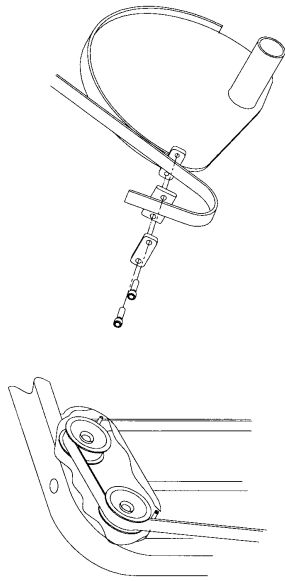

BELT ROUTING DETAIL

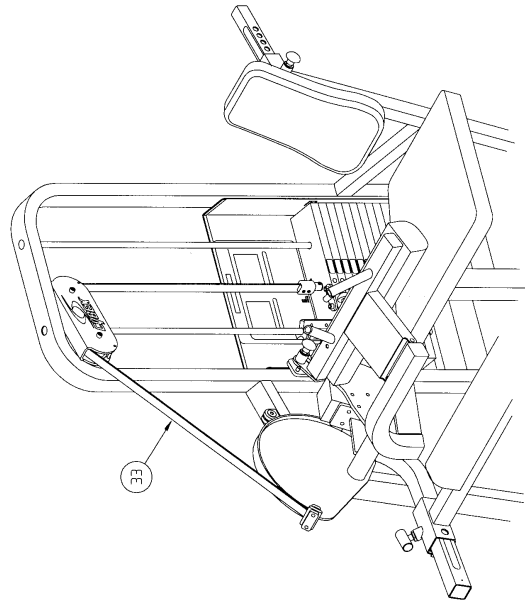

BELT ROUTING DETAIL

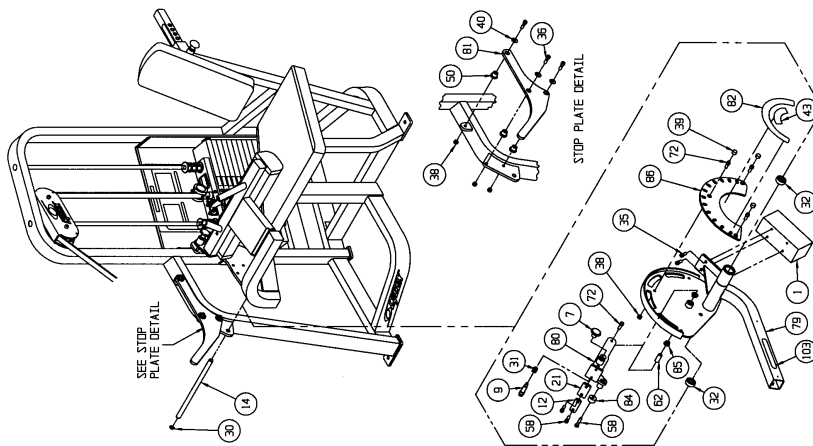

4627 - Seated Leg Curl Start RLD

HIP ADDUCTION

PRODUCT NO. 4640

PARTS LIST

Note: Item D - Weight Stack Belt = 105" Long
Item D - Rear Belt = 29" Long

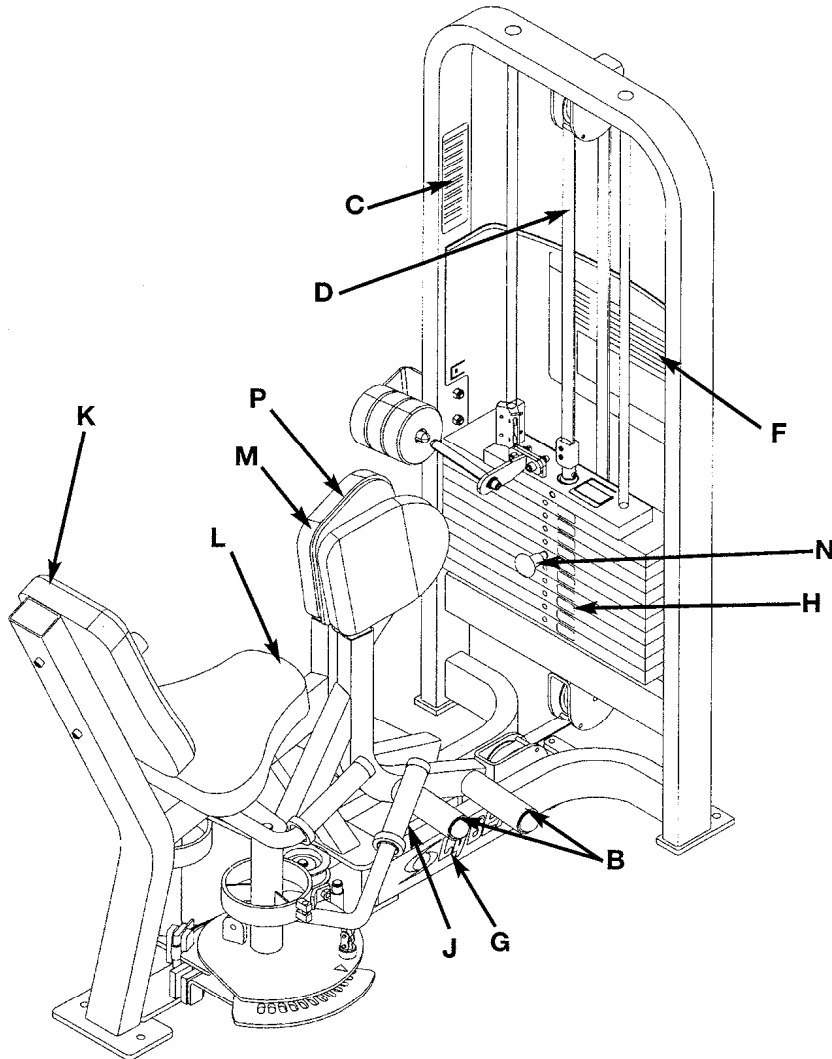

NOTE: See the exploded-view diagram for items:
A (#4), E (#12), I (#67 K) and O (Serial Number Decal).

DESCRIPTION	PART NO.	DESCRIPTION	PART NO.
A. Cable Subassembly	4140-004	I. Caution Decal.....	4605-424
B. Grip.....	4140-329	J. Grip.....	4605-500
C. Warning Decal	4605-381	K. Back Cushion.....	4800-115
D. Belt	GB000202	L. Seat Cushion	4800-025
E. Cybex Decal Blk/Plm	3900-391	M. Leg Cushion/Wear	
E. Cybex Decal Wht/Wht ..	3900-419	Cover	4800-018
F. Placard Decal	4640-598	N. Weight Selector Pin.....	BH030207
G. Cybex Decal Blkt/Plm ...	3900-390	O. Serial Number Decal	
G. Cybex Decal Wht/Wht...	3900-415	P. Wear Cover (Item M).....	4800-090
H. Weight Plate Decal.....	4605-388		

4640 - Hip Adduction

ITEM	QTY	PART NO.	DESCRIPTION	ITEM	QTY	PART NO.	DESCRIPTION
1	1	01989	Single Connecting Link	55 A	2	4800-018	Leg Cushion w/Wear Cover
2	4	08001	Plug	55 B	2	4800-090	Wear Cover
3			Removed	56	2	HC702834	SHCS .375-16 x 3.00
4	2	4140-004	Cable Subassembly	57	6	JC702820	SHCS .375-16 x 1.25
5	1	4140-324	Detent Pin	58	1	4701-020	Weight Stack Guide Rod Set
6	4	4140-329	Grip 5" Long	58 A	2	4535-329	Weight Stack Guide Rod
7	1	PR070002	Foot Pad 4.00 x 7.00	58 B	4	BR030214	Retaining Ring .625
8	3	4605-300	Belt Clamp	58 C	2	HS407100	Spring Washer .65 x .79 x .062 T
9	2	PR070003	Foot Pad 2.00 x 5.25	58 D	2	PN660200	Plastic Insert 1.00 Dia x 11 G
10	3	11090-374	End Cap	58 E	2	PR060005	Weight Bumper
11	1	4605-381	Warning Decal	59			Not Used
12			Removed 3/03	60			Not Used
12	1	3900-391	Cybex Decal 11.37 Vert. Blk/Plm	61			Not Used
12	1	3900-419	Cybex Decal 11.37 Vert. Wht/Wht	62			Not Used
13	1	4605-388	Weight Plate Decal 10-290	63			Not Used
14	3	4605-394	Belt Clamp	64			Removed
15	1	4640-200	Frame	65			Not Used
16	1	4640-201	Input Arm (Right Hand)	66			Not Used
17	1	4640-202	Input Arm (Left Hand)	67	1	4701-030	Sliding Increment Weight Set
18	1	4640-203	Cam	67 A	1	11040-216	Belt Clamp
19	1	4640-204	Handle	67 B	1	11040-301	Belt Clamp Insert
20	1	4640-205	Pulley	67 C	3	4605-390	Increment Weight
21	1	4640-301	Cam Plate	67 D			Removed 3/03
22	1	4640-302	Input Cam Decal	67 E	1	BH030207	Weight Selector Pin
23	1	4640-598	Placard Decal	67 F	1	4701-001	Top Weight Guide
24	1	4505-431	Guard	67 G	2	HC702817	SHCS .375-16 x 1.00
25	1	5340Y045	Arrow Decal	67 H	2	HC702828	SHCS .375-16 x 2.25
26	5	BR030210	Retaining Ring 17 mm	67 I	4	HN704901	Nylon Locknut .375-16
27	1	BS070201	Com Spring .56 x .66 x 1.50 L	67 J	4	HS347600	Washer, SAE .375
28	4	FB030232	Radial Brg 17 mm ID (Ext Race)	67 K	3	HY740000	Set Screw
29	2	FB130206	Flange Brg 2.00 x 2.25 x 1.00 L	67 L	1	4605-424	Caution Decal
30 A	105"	GB000202	Belt .95" Wide	67 M	1	4700-240	Weight Mount
30 B	29"	GB000202	Belt .95" Wide	67 N	2	4700-318	Increment Weight Rod
31	3	GP000209	Pulley Assembly 3.50	67 O	1	4700-319	Frame Mount Increment Weigh
32	1	GP000212	Pulley Assembly 3.50	67 P	1	FB130208	Bearing Sleeve .68 x .81 1.00 L
33	5	HC702817	SHCS .375-16 x 1.00	67 Q	2	4700-321	Rubber Washer
34	6	HC702822	SHCS .375-16 x 1.50	67 R	2	JC702820	SHCS .375-16 x 1.25
35	3	HC702830	SHCS .375-16 x 2.50	67 S	2	HS348300	Split Lockwasher .375
36	10	HN704901	Nylon Locknut .375-16	67 T	1	4700-239	Top Weight
37			Not Used	67 U	3	HC702816	SHCS .375-16 x .875
38	4	HT102214	Tap Screw #10-12 x .625 A (Phil)	68			Removed
39	2	JC702824	SHCS .375-16 x 1.75	69			Not Used
40	2	JN714200	Hex Nut .375-24	70			Not Used
41	2	JN714400	Jam Nut .375-24	71			Not Used
42			Removed 8/98	72			Not Used
43	1	PP080205	Cap	73			Not Used
44	1	PP090206	Plastic Insert	74			Not Used
45	2	PR060003	Recess Bumper	75			Removed 3/03
46	3	4605-500	Grip 6" Long	75	1	3900-390	Cybex Decal 1.57 Horiz. Blk/Plm
47	1	PU060201	Bumper	75	1	3900-415	Cybex Decal 1.57 Horiz. Wht/Wht
48	1	4535-328	Short Pivot Pin	76			Not Used
49	2	4605-334	Pivot Shaft 13.06	77	1	4701-302	VR2 Weight Stack Instr. (not shown)
50	2	FB130205	Flange Brg .62 x .75 x .88 L	78	1	51198	Strength Warranty Sheet (not shown)
51	2	PP090000	Plastic Insert 1.50 x 2.00 x 11 G	79	3	HF449063	Tube Insert
52	2	PP090202	Plastic Insert 1.50 x 3.00 x 11 G	80	9	4000C101	Stack Weight 4 x 18 (not shown)
53	1	4800-115	Back Cushion	81	3	11090-376	Handle Grip Ring
54	1	4800-025	Seat Cushion	82	3	JC620422	BHSCS .250-20 x 1.50
55 A	2	4800-018	Leg Cushion w/Wear Cover	83	8	JS347400	Internal Tooth Lockwasher

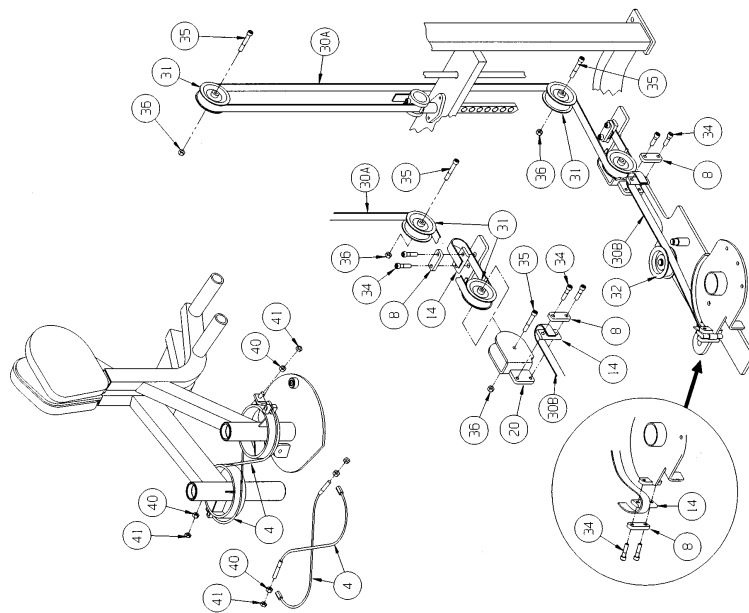

BELT ROUTING DETAIL

HIP ABDUCTION

PRODUCT NO. 4645

PARTS LIST

Note: Item D - Weight Stack Belt = 95" Long
Item D - Rear Belt = 25" Long

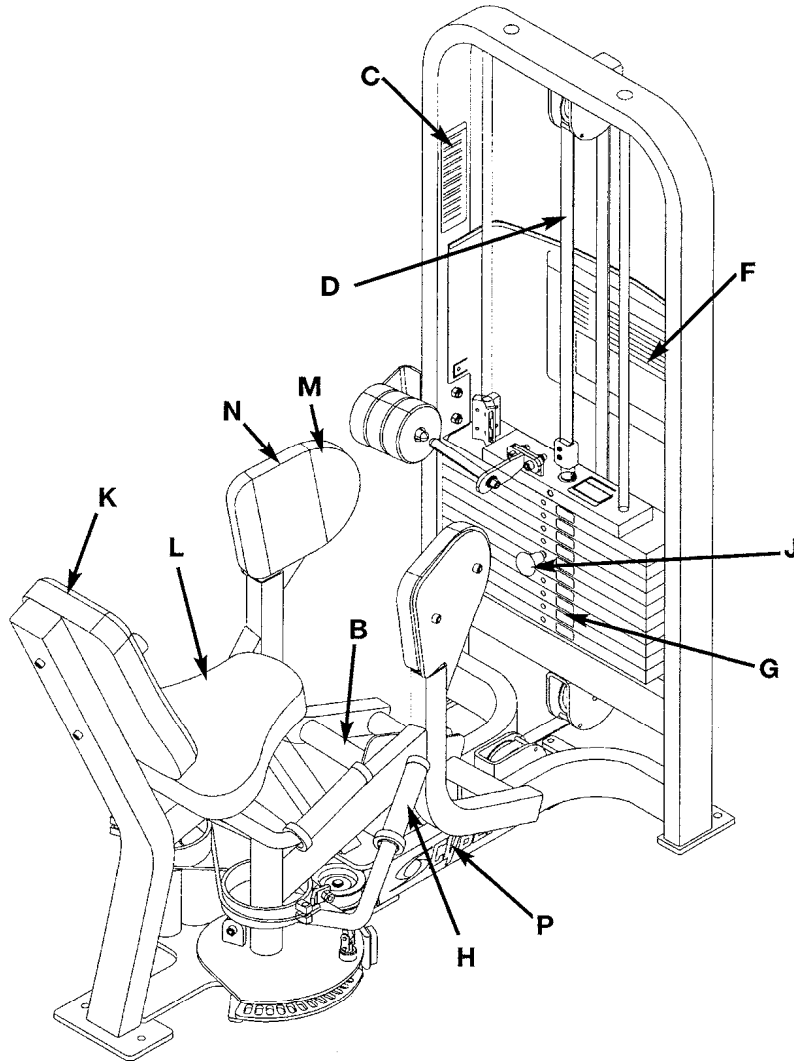

NOTE: See the exploded-view diagram for items:
A (#4), E (#12), I (Serial Number Decal) and O (#67 K).

DESCRIPTION	PART NO.	DESCRIPTION	PART NO.
A. Cable Subassembly	4140-004	J. Weight Selector Pin.....	BH030207
B. Rubber Grip	4140-329	K. Back Cushion	4800-115
C. Warning Decal	4605-381	L. Seat Cushion	4800-025
D. Belt	GB000202	M. Leg Cushion w/Wear Cover.....	4800-018
E. Cybex Decal Blk/Plm	3900-391	N. Wear Cover (Item M)	4800-090
E. Cybex Decal Wht/Wht ..	3900-419	O. Caution Decal	4605-424
F. Placard Decal.....	4640-598	P. Cybex Decal Blk/Plm	3900-390
G. Weight Plate Decal.....	4605-388	P. Cybex Decal Wht/Wht ..	3900-415
H. Grip	4605-500		
I. Serial Number Decal			

4645 - Hip Abduction

ITEM	QTY	PART NO.	DESCRIPTION	ITEM	QTY	PART NO.	DESCRIPTION
1	1	01989	Single Connecting Link	55 A	2	4800-018	Leg Cushion w/Wear Cover
2	2	4145-300	Foot Guard	55 B	2	4800-090	Wear Cover
3			Removed	56	2	HC702834	SHCS .375-16 x 3.00
4	2	4140-004	Cable Subassembly	57	6	JC702820	SHCS .375-16 x 1.25
5	1	4140-324	Detent Pin	58	1	4701-020	Weight Stack Guide Rod Set
6	4	4140-329	Grip 5" Long	58 A	2	4535-329	Weight Stack Guide Rod
7	2	PR070002	Foot Pad 4.00 x 7.00	58 B	4	BR030214	Retaining Ring .625
8	3	4605-300	Belt Clamp	58 C	2	HS407100	Spring Washer .65 x .79 x .062 T
9	2	PR070003	Foot Pad 2.00 x 5.25	58 D	2	PN660200	Plastic Insert 1.00 Dia x 11 G
10	3	11090-374	End Cap	58 E	2	PR060005	Weight Bumper
11	1	4605-381	Warning Decal	59			Not Used
12			Removed 3/03	60			Not Used
12	1	3900-391	Cybex Decal 11.37 Vert. Blk/Plm	61			Not Used
12	1	3900-419	Cybex Decal 11.37 Vert. Wht/Wht	62			Not Used
13	1	4605-388	Weight Plate Decal 10 - 290	63			Not Used
14	3	4605-394	Belt Clamp	64			Removed
15	1	4640-200	Frame	65			Not Used
16	1	4645-201	Right Hand Input Arm	66			Not Used
17	1	4645-202	Left Hand Input Arm	67	1	4701-03	Sliding Increment Weight Set
18	1	4645-203	Cam	67 A	1	11040-216	Belt Clamp
19	1	4640-204	Handle	67 B	1	11040-301	Belt Clamp Insert
20	1	4640-205	Pulley	67 C	3	4605-390	Increment Weight
21	1	4645-305	Cam Plate	67 D			Removed 3/03
22			Not Used	67 E	1	BH030207	Weight Selector Pin
23	1	4645-597	Placard Decal	67 F	1	4701-001	Top Weight Guide
24	1	4505-431	Guard	67 G	2	HC702817	SHCS .375-16 x 1.00
25	4	HT622517	Tap Screw .250-20 x 1.00 F (Phil)	67 H	2	HC702828	SHCS .375-16 x 2.25
26	5	BR030210	Retaining Ring 17 mm	67 I	4	HN704901	Nylon Locknut .375-16
27	1	BS070201	Com Spring .56 x .66 x 1.50 L	67 J	4	HS347600	Washer, SAE .375
28	4	FB030232	Radial Bearing 17 mm ID (Ext Race)	67 K	3	HY740000	Set Screw
29	2	FB130206	Flange Bearing 2.00 x 2.25 x 1.00 L	67 L	1	4605-424	Caution Decal
30 A	105"	GB000202	Belt .95" Wide	67 M	1	4700-240	Weight Mount
30 B	25"	GB000202	Belt .95" Wide	67 N	2	4700-318	Increment Weight Rod
31	3	GP000209	Pulley Assembly 3.50	67 O	1	4700-319	Frame Mount Increment Weight
32	1	GP000212	Pulley Assembly 3.50	67 P	1	FB130208	Bearing Sleeve .68 x .81 1.00 L
33	5	HC702817	SHCS .375-16 x 1.00	67 Q	2	4700-321	Rubber Washer
34	6	HC702822	SHCS .375-16 x 1.50	67 R	2	JC702820	SHCS .375-16 x 1.25
35	3	HC702830	SHCS .375-16 x 2.50	67 S	2	HS348300	Split Lockwasher .375
36	10	HN704901	Nylon Locknut .375-16	67 T	1	4700-239	Top Weight
37			Not Used	67 U	3	HC702816	SHCS .375-16 x .875
38	4	HT102214	Tap Screw #10-12 x .625 A (Phil)	68			Removed
39	2	JC702824	SHCS .375-16 x 1.75	69			Not Used
40	2	JN714200	Hex Nut .375-24	70			Not Used
41	2	JN714400	Jam Nut .375-24	71			Not Used
42			Removed 8/98	72			Not Used
43	1	PP080205	Cap	73			Not Used
44	1	PP090206	Plastic Insert	74			Removed 3/03
45	1	PR060003	Recess Bumper	74	2	3900-390	Cybex Decal 1.57 Vert. Blk/Plm
46	3	4605-500	Grip 6" Long	74	2	3900-415	Cybex Decal 1.57 Vert. Wht/Wht
47	1	PU060201	Bumper	75	1	51198	Strength Warranty Sheet (not shown)
48	1	4535-328	Short Pivot Pin	76	3	HF449063	Tube Insert
49	2	4605-334	Pivot Shaft 13.06	77	1	4701-302	VR2 Weight Stack Instr. (not shown)
50	2	FB130205	Flange Bearing .62 x .75 x .88 L	78	9	4000C101	Stack Weight 4 x 18 (not shown)
51	2	PP090000	Plastic Insert 1.50 x 2.00 x 11 G	79	3	11090-376	Handle Grip Rind
52	2	PP090202	Plastic Insert 1.50 x 3.00 x 11 G	80	3	JC620422	BHSCS .250-20 x 1.50
53	1	4800-021	Back Cushion	81	8	11990-376	Handle Grip Ring
54	1	4800-025	Seat Cushion	82	8	JS347400	Internal Tooth Lockwasher

HIP ABDUCTION - 4645

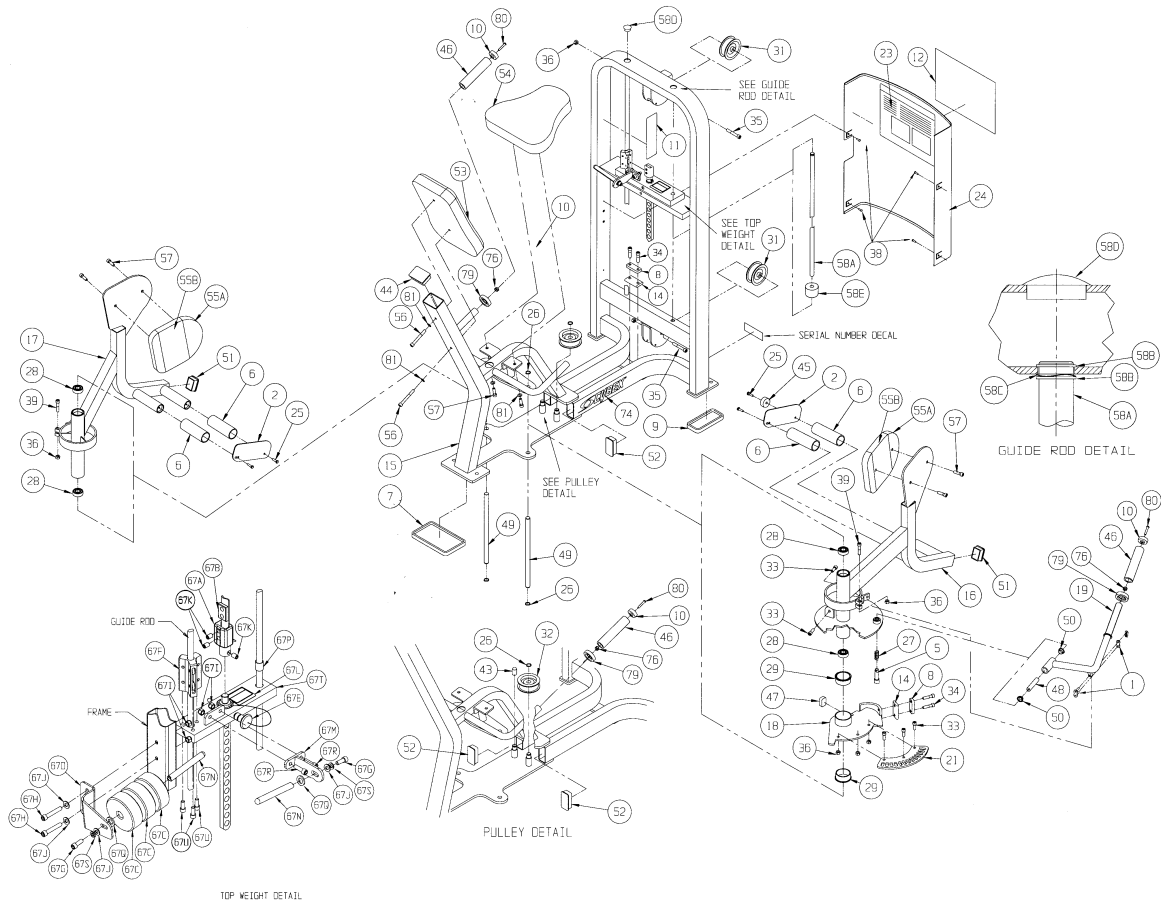

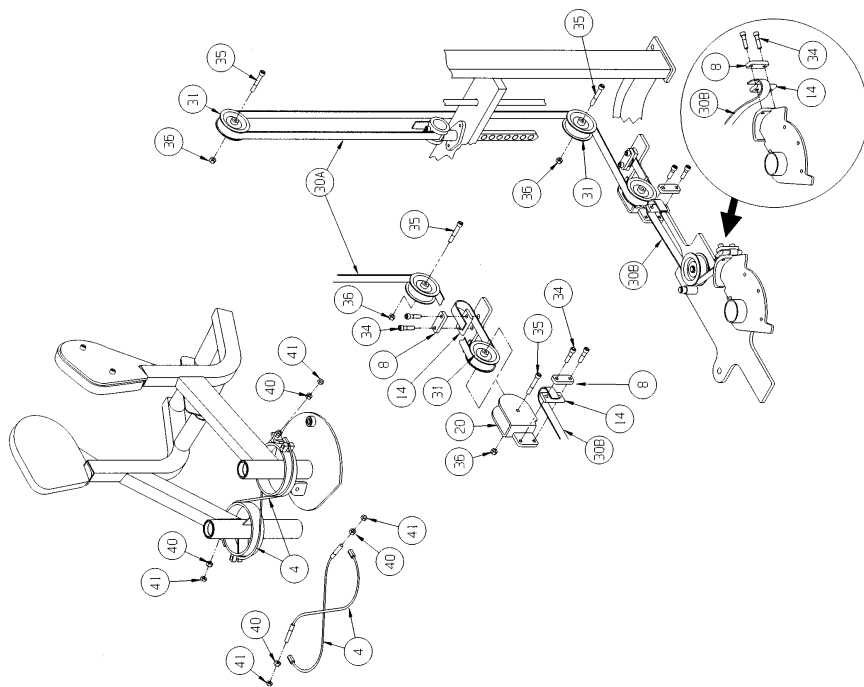

BELT ROUTING DETAIL

AB CRUNCH

PRODUCT NO. 4705

PARTS LIST

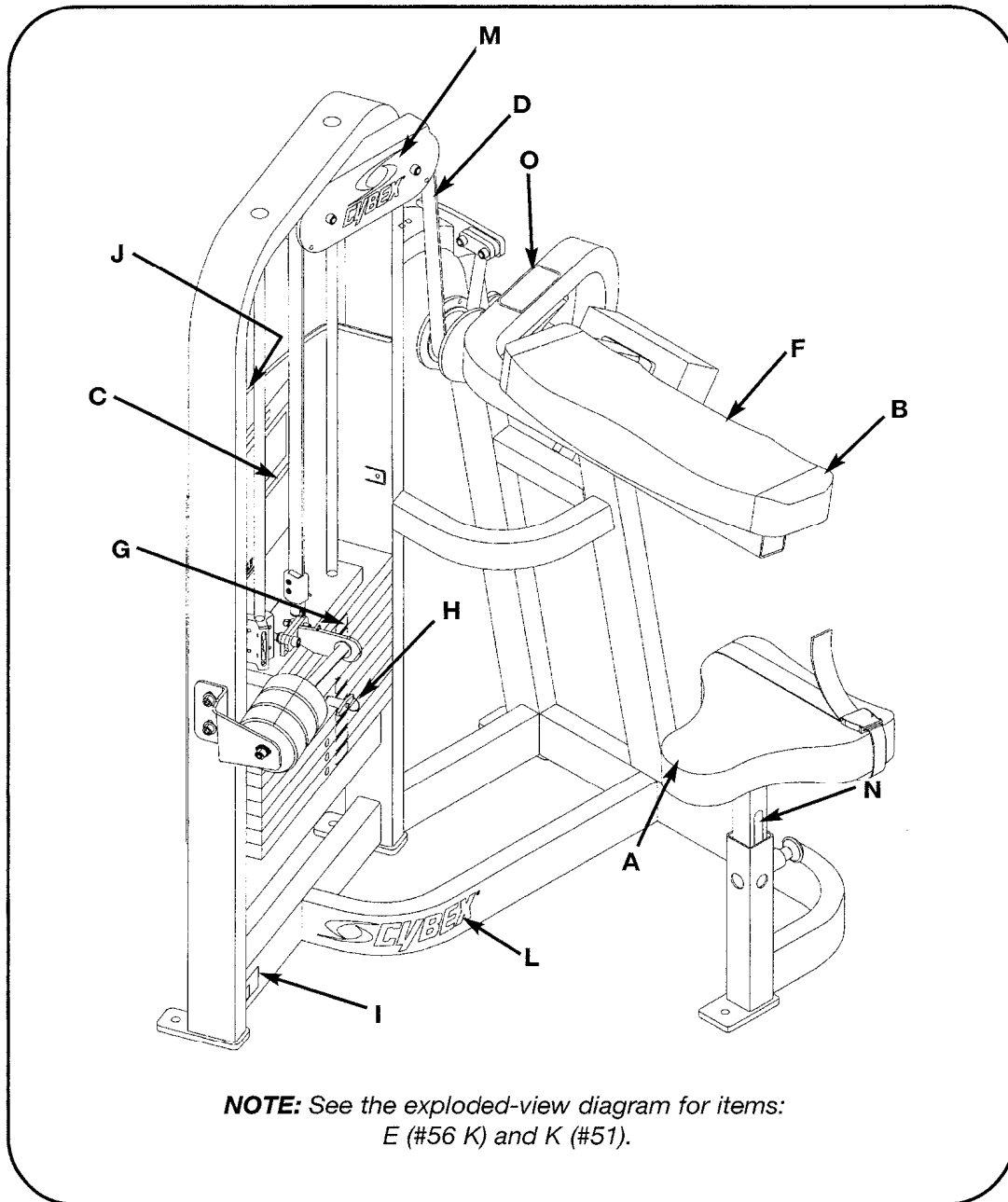

DESCRIPTION	PART NO.	DESCRIPTION	PART NO.
A. Seat Cushion.....	4800-026	J. Warning Decal	4605-381
B. Chest Cushion w/Wear Cover.....	4800-072	K. Cybex Decal Blk/Plm	3900-391
C. Placard Decal.....	4705-323	K. Cybex Decal Wht/Wht ..	3900-419
D. Belt 71" Long	GB000202	L. Cybex Decal Blk/Plm ...	3900-390
E. Caution Decal.....	4605-424	L. Cybex Decal Wht/Wht...	3900-415
F. Wear Cover (Item B).....	4800-102	M. Cybex Decal Blk/Plm	3900-423
G. Weight Plate Decal.....	4605-388	M. Cybex Decal Wht/Wht...	3900-424
H. Weight Selector Pin.....	BH030207	N. Adjusting Decal	4705-327
I. Serial Number Decal		O. Caution Decal	4705-325

4705 - Ab Crunch

ITEM	QTY	PART NO.	DESCRIPTION	ITEM	QTY	PART NO.	DESCRIPTION
1	1	11040-440	Cybex Knob	47			Not Used
2	1	PR070001	Foot Pad 2.50 x 4.25	48	1	4505-431	Guard
3	1	4701-021	Weight Stack Guide Rod Set	49	1	4605-381	Warning Decal
3 A	2	4505-319	Weight Stack Guide Rod	50	1	3900-423	Cybex Decal 4.85 Vert. Blk/Plm
3 B	4	BR030214	Retaining Ring .625	50	1	3900-424	Cybex Decal 4.85 Vert. Wht/Wht
3 C	2	HS407100	Spring Washer .65 x .79 x .062 T	50			Removed 3/03
3 D	2	PN660200	Plastic Insert 1.00 Dia x 11 G	51			Removed 3/03
3 E	2	PR060005	Weight Bumper	51	1	3900-391	Cybex Decal 11.37 Vert. Blk/Plm
4	1	4800-026	Seat Cushion	51	1	3900-419	Cybex Decal 11.37 Vert. Wht/Wht
5			Removed	52	4	HT102214	Tap Screw #10-12 x .625 A (Phil)
6	1	4605-300	Belt Clamp	53			Removed 8/98
7	1	4605-334	Pivot Shaft 13.06	54	1	4605-394	Belt Clamp
8	1	4605-512	Plastic Insert 7.94	55			Removed 8/98
9	3	PR070003	Foot Pad 2.00 x 5.25	56	1	4701-030	Sliding Increment Weight Set
10 A	1	4800-072	Chest Cushion w/Wear Cover	56 A	1	11040-216	Belt Clamp
10 B	1	4800-102	Wear Cover	56 B	1	11040-301	Belt Clamp Insert
11	1	4705-200	Frame	56 C	3	4605-390	Increment Weight
12	1	4705-201	Arm	56 D			Removed 3/03
13	1	4705-204	Seat	56 E	1	BH030207	Weight Selector Pin
14	1	4505-329	Detent Pin	56 F	1	4701-001	Top Weight Guide
15	1	4705-319	Counterweight	56 G	2	HC702817	SHCS .375-16 x 1.00
16	1	4705-323	Placard Decal	56 H	2	HC702828	SHCS .375-16 x 2.25
17	2	BR030210	Retaining Ring 17 mm	56 I	4	HN704901	Nylon Locknut .375-16
18			Not Used	56 J	4	HS347600	Washer, SAE .375
19	1	BS070201	Com Spring .56 x .66 x 1.50 L	56 K	3	HY740000	Set Screw
20			Not Used	56 L	1	4605-424	Caution Decal
21	2	FB030232	Radial Brg 17 mm ID (Ext Race)	56 M	1	4700-240	Weight Mount
22	71'	GB000202	Belt .95" Wide	56 N	2	4700-318	Increment Weight Rod
23	3	GP000209	Pulley Assembly 3.50	56 O	1	4700-319	Frame Mount Increment Weight
24			Not Used	56 P	1	FB130208	Bearing Sleeve .68 x .81 1.00 L
25	3	HC702830	SHCS .375-16 x 2.50	56 Q	2	4700-321	Rubber Washer
26	2	HC702834	SHCS .375-16 x 3.00	56 R	2	JC702820	SHCS .375-16 x 1.25
27	5	HN704901	Nylon Locknut .375-16	56 S	2	HS348300	Split Lockwasher .375
28			Not Used	56 T	1	4700-239	Top Weight
29	3	JC702814	SHCS .375-16 x .625	56 U	3	HC702816	SHCS .375-16 x .875
30	2	JC702820	SHCS .375-16 x 1.25	57	2	HC702828	SHCS .375-16 x 2.25
31	1	PP090202	Plastic Insert 1.5 x 3.0 -11 GA	58	1	HY710408	Set Screw .375-16 x .25 Cup Pt.
32	1	PP090210	Plastic Insert 2.00 sq x 10-14 GA	59			Removed 8/98
33			Removed	60	1	4701-302	VR2 Weight Stack Instr. (not shown)
34	1	PU060203	Bumper	61	1	51198	Strength Warranty Sheet (not shown)
35	1	UB050202	Seat Belt (Buckle Half)	62	1	PP460011	Knob .375 -16
36	1	UB050204	Seat Belt (Connector Half)	63	1	AA033904	V-Pusher
37			Not Used	64	1	HM532812	SHCS .138.6-32 x .500
38			Not Used	65	1	4605-424	Caution Decal
39	1	4605-388	Weight Plate Decal 10-290	66			Removed 3/03
40			Not Used	66	1	3900-390	Cybex Decal 1.57 Horiz. Blk/Plm
41			Not Used	66	1	3900-415	Cybex Decal 1.57 Horiz. Wht/Wht
42			Not Used	67	1	4705-327	Adjusting Decal
43			Not Used	68	1	4705-325	Caution Decal
44	2	HC702822	SHCS .375-16 x 1.50	69	1	4705-332	Threaded Insert .375-16 x .562-12
45			Not Used	70	9	4000C101	Stack Weight 4 x 18 (not shown)
46			Not Used	71	4	JS347400	Internal Tooth Lockwasher

AB CRUNCH - 4705

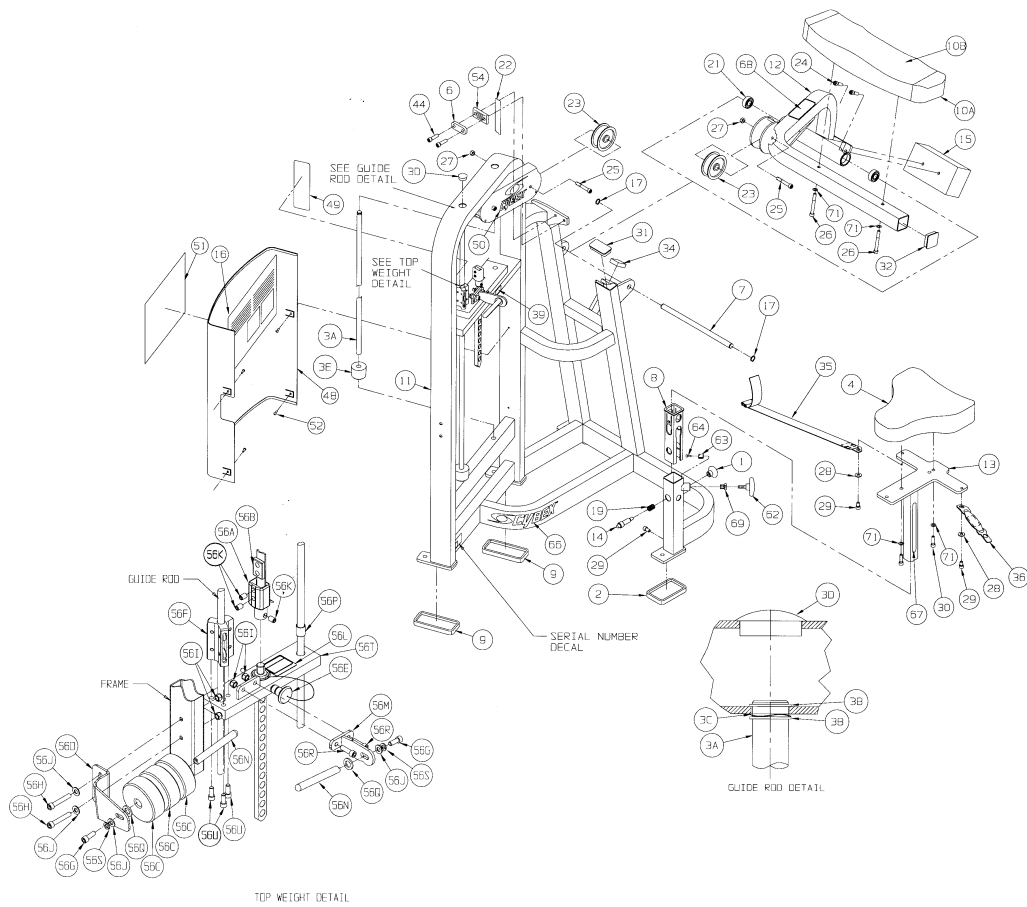

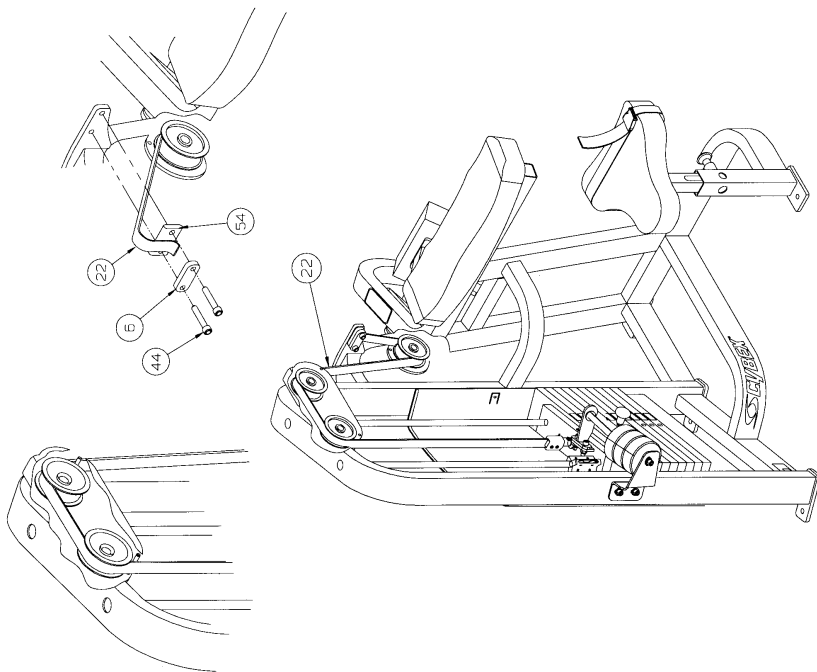

BELT ROUTING DETAIL

BACK EXTENSION

PRODUCT NO. 4711, 4712, 4713

PARTS LIST

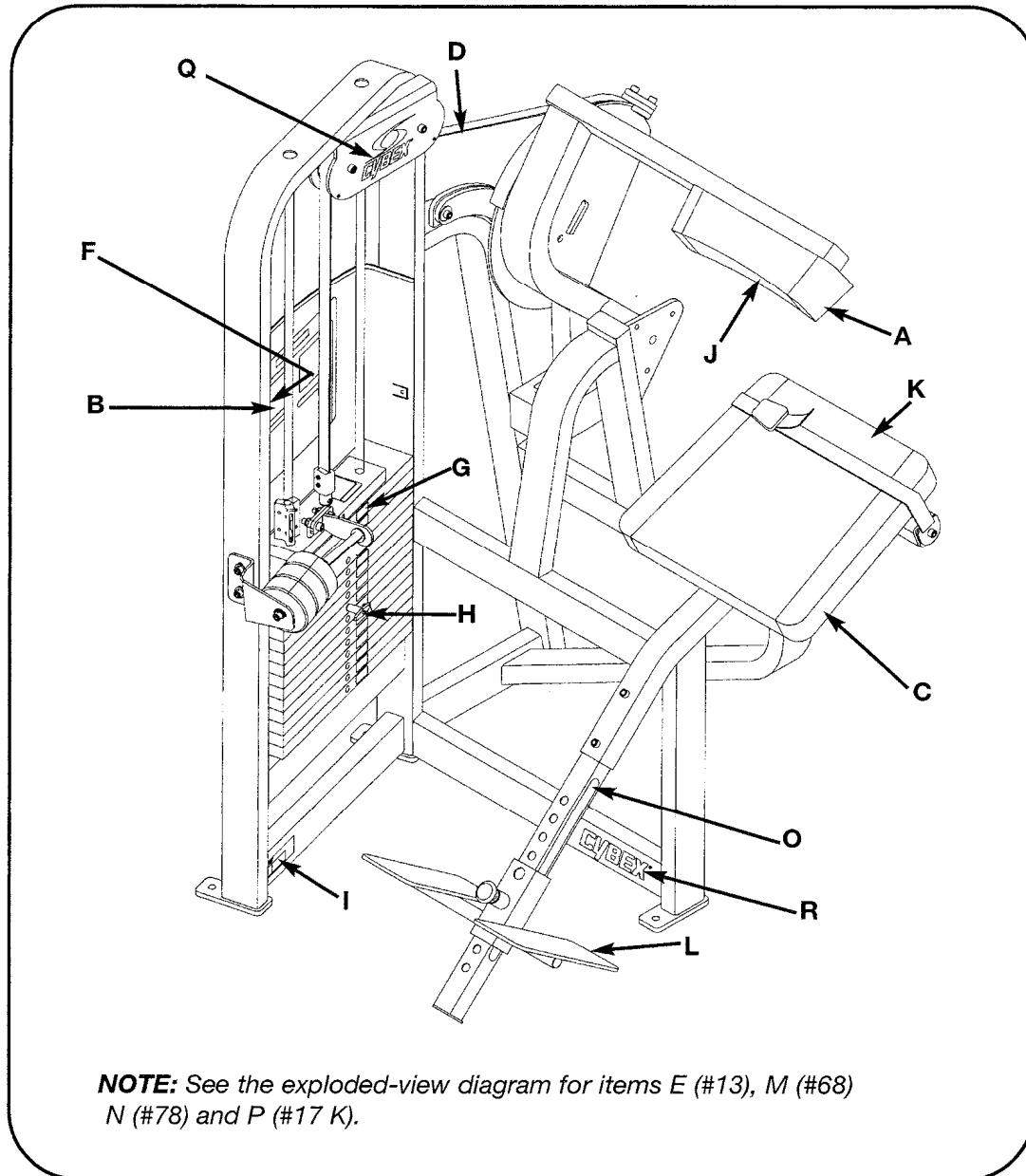

DESCRIPTION	PART NO.	DESCRIPTION	PART NO.
A. Back Cushion.....	4800-014	K. Wear Cover (Item C).....	4207S072-0
B. Placard Decal.....	4710-322	L. Non-Slip	4710-321
C. Seat Cushion.....	4800-015	M. Caution Decal.....	8500-026
D. Belt 70" long.....	GB000202	N. Grip	4605-515
E. Cybex Decal Blk/Plm	3900-391	O. Adjusting Decal	4890-315
E. Cybex Decal Wht/Wht...	3900-419	P. Caution Decal.....	4605-424
F. Warning Decal.....	4605-381	Q. Cybex Decal Blk/Plm	3900-423
G. Weight Plate Decal.....	4605-388	Q. Cybex Decal Wht/Wht ..	3900-424
H. Weight Selector Pin.....	BH030207	R. Cybex Decal Blk/Plm	3900-390
I. Serial Number Decal		R. Cybex Decal Wht/Wht...	3900-415
J. Wear Cover (Item A)	4800-094		

4711, 4712, 4713 - Back Extension

ITEM	QTY	PART NO.	DESCRIPTION	ITEM	QTY	PART NO.	DESCRIPTION
1	3	11040-440	Cybex Knob	33			Not Used
2	1	4701-021	Weight Stack Guide Rod Set	34	3	BS070201	Com Spring .56 X .66 X 1.50 I
2 A	2	4505-319	Weight Stack Guide Rod	35			Not Used
2 B	4	BR030214	Retaining Ring .625	36			Removed
2 C	2	HS407100	Spring Washer .65 x .79 x .062 T	37	2	FB030232	Radial Brg 17 mm ID (Ext Race)
2 D	2	PN660200	Plastic Insert 1.00 Dia x 11 G	38	4	FB130209	Flange Brg .375 x .50 x .125
2 E	2	PR060005	Weight Bumper	39	70"	GB000202	Belt .95" Wide
3	1	4505-432	Guard	40	2	GP000209	Pulley Assembly 3.50
4			Not Used	41	4	HC702817	SHCS .375-16 x 1.00
5			Removed	42	3	HC702822	SHCS .375-16 x 1.50
6	1	4605-300	Belt Clamp	43	6	HC702830	SHCS .375-16 x 2.50
7	1	4605-322	Detent Pin	44	4	HC702834	SHCS .375-16 x 3.00
8	1	4605-334	Pivot Shaft 13.06	45	12	HN704901	Nylon Locknut .375-16
9	1	4605-348	Belt Clamp Insert	46	1	UB050204	Seat Belt-Connector Half 7"
10	4	PR070003	Foot Pad 2.00 X 5.25	47			Not Used
11	1	4605-381	Warning Decal	48			Not Used
12	1	3900-423	Cybex Decal 4.85 Vert. Blk/Plm	49	4	HT102214	Tap Screw #10-12 x .625 A (Phil)
12	1	3900-424	Cybex Decal 4.85 Vert. Wht/Wht	50			Not Used
12			Removed 3/03	51			Removed 8/98
13			Removed 3/03	52	1	UB050202	Seat Belt - Buckle Half
13	1	3900-391	Cybex Decal 11.37 Vert. Blk/Plm	53			Not Used
13	1	3900-419	Cybex Decal 11.37 Vert. Wht/Wht	54	1	PP090202	Plastic Insert 1.50 x 3.00 x 11 G
14	1	4605-388	Weight Plate Decal 10-290	55	3	HS347700	Washer .375 USS
15			Not Used	56			Removed
16	1	4605-394	Belt Clamp	57	1	PU060203	Bumper
17	1	4701-030	Sliding Increment Weight Set	58	7	HC702816	SHCS .375-16x .875
17 A	1	11040-216	Belt Clamp	59	1	4711-211	Bar Stop
17 B	1	11040-301	Belt Clamp Insert	60	3	PR740300	Center Bonded Mount
17 C	3	4605-390	Increment Weight	61	2	PU060201	Bumper
17 D			Removed 3/03	62	1	4713-318	Detent Pin
17 E	1	BH030207	Weight Selector Pin	63	1	4713-314	Cam Stop Decal
17 F	1	4701-001	Top Weight Guide	64	1	4713-205	Cam Arm
17 G	2	HC702817	SHCS .375-16 x 1.00	65	1	4713-303	Cam Plate
17 H	2	HC702828	SHCS .375-16 x 2.25	66	1	4713-312	Bar Stop
17 I	4	HN704901	Nylon Locknut .375-16	67	1	4713-313	Start Cam Decal
17 J	4	HS347600	Washer, SAE .375	68	1	8500-026	Caution Decal
17 K	3	HY740000	Set Screw	69	1	4713-323	Counterweight
17 L	1	4605-424	Caution Decal	70	2	4715-336	Washer
17 M	1	4700-240	Weight Mount	71	2	BR030213	Retaining Ring 2.00 (Ext)
17 N	2	4700-318	Increment Weight Rod	72	1	FB030239	Cam Follower
17 O	1	4700-319	Frame Mount Increment Weight	73	2	FB130205	Flange Brg .63 x .75 x .38 L
17 P	1	FB130208	Bearing Sleeve .68 x .81 1.00 L	74	2	FB130206	Flange Brg 2.00 x 2.25 x 1.00 L
17 Q	2	4700-321	Rubber Washer	75	1	4713-204	Detent Plate
17 R	2	JC702820	SHCS .375-16 x 1.25	76	4	PP080222	Vinyl End Cap
17 S	2	HS348300	Split Lockwasher .375	77	2	PP090001	Plastic Insert 1.50 x 2.50
17 T	1	4700-239	Top Weight	78	1	4506-515	Grip 3.25" Long
17 U	3	HC702816	SHCS .375-16 x .875	79	1	4713-203	Start Stop
18			Removed	80			Removed
19	1	4713-323	Counterweight	81	1	4505-329	Detent Pin
20 A	1	4800-014	Back Cushion w/Wear Cover	82	1	4612-596	Start RLD Decal
20 B	1	4800-094	Wear Cover	83	1	4613-302	Short Pivot Pin
21 A	1	4800-015	Seat Cushion w/Wear Cover	84	3	JC702820	SHCS .375-16 x 1.25
21 B	1	4207S072-0	Wear Cover	85	1	4713-594	Total RLD Decal
22	1	4711-200	Frame	86	1	4713-201	Cam
23	1	4711-210	Cam	87			Not Used
24	1	4710-205	Footrest	88	1	4701-302	VR2 Weight Stack Instr. (not shown)
25	1	4710-203	Cushion Support	89	1	51198	Strength Warranty Sheet (not shown)
26	1	4710-206	Adjusting Tube	90			Removed 3/03
27	4	4710-320	Slide Plate	90	1	3900-390	Cybex Decal 1.57 Hori. Blk/Plm
28	2	4710-321	Non-Slip	90	1	3900-415	Cybex Decal 1.57 Hori. Wht/Wht
29	1	4710-322	Placard Decal	91	1	4890-315	Adjusting Decal
30			Not Used	92	14	4000C101	Stack Weight 4 x 18 (not shown)
31			Not Used	93	4	JS347400	Internal Tooth Lockwasher
32	1	BR30210	Retaining Ring 17 mm				

BACK EXTENSION - 4711, 4712, 4713

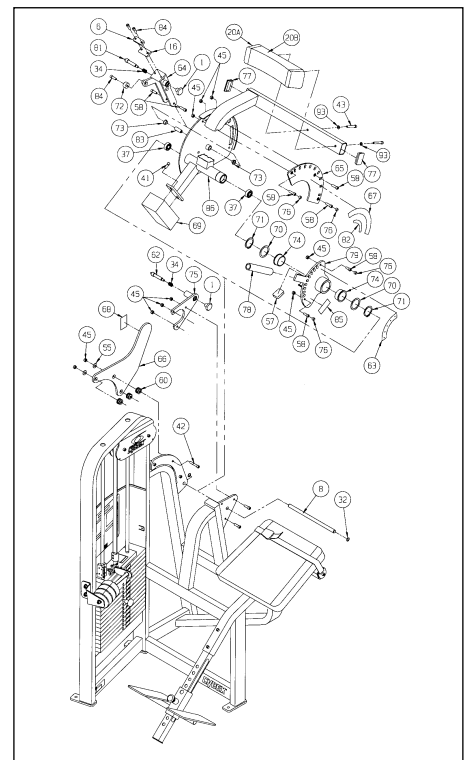
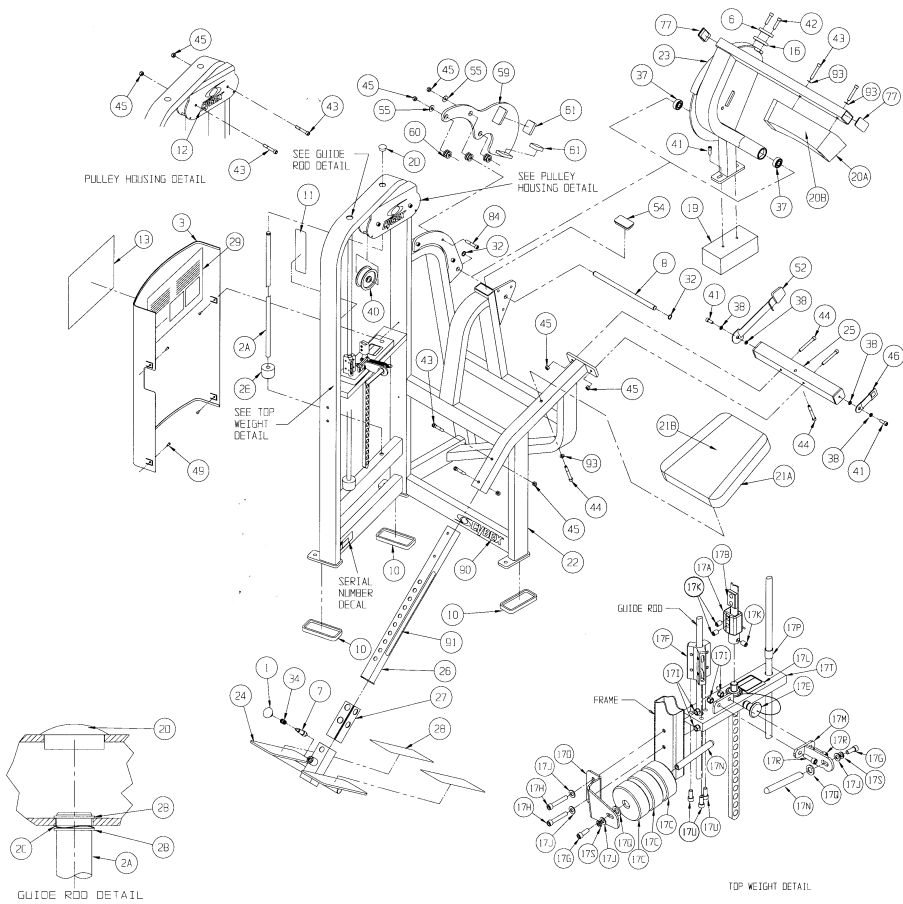

4713 - Back Extension Total RLD

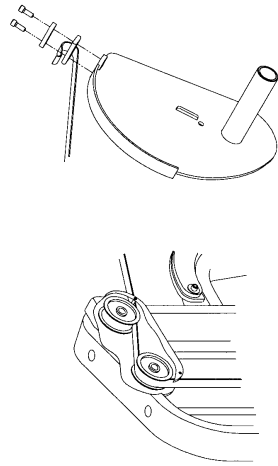

BELT ROUTING DETAIL

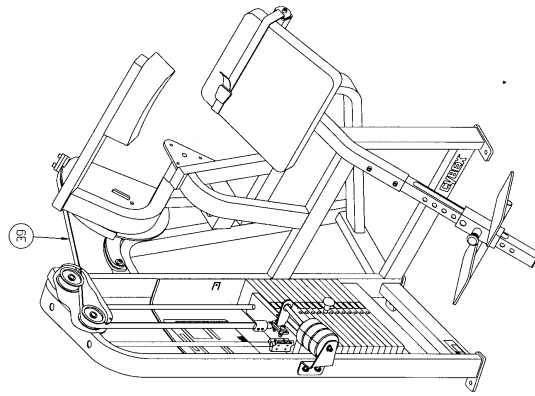

BELT ROUTING DETAIL

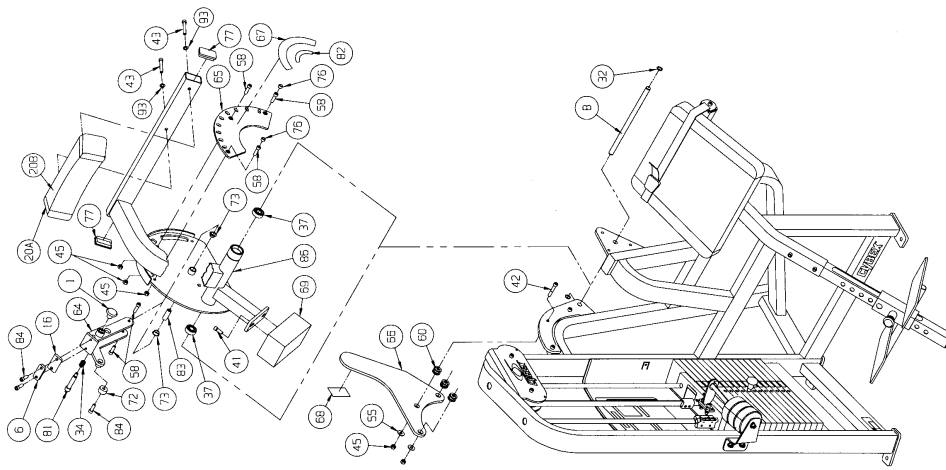

4712 - Back Extension Start RLD

TORSO ROTATION

PRODUCT NO. 4715

PARTS LIST

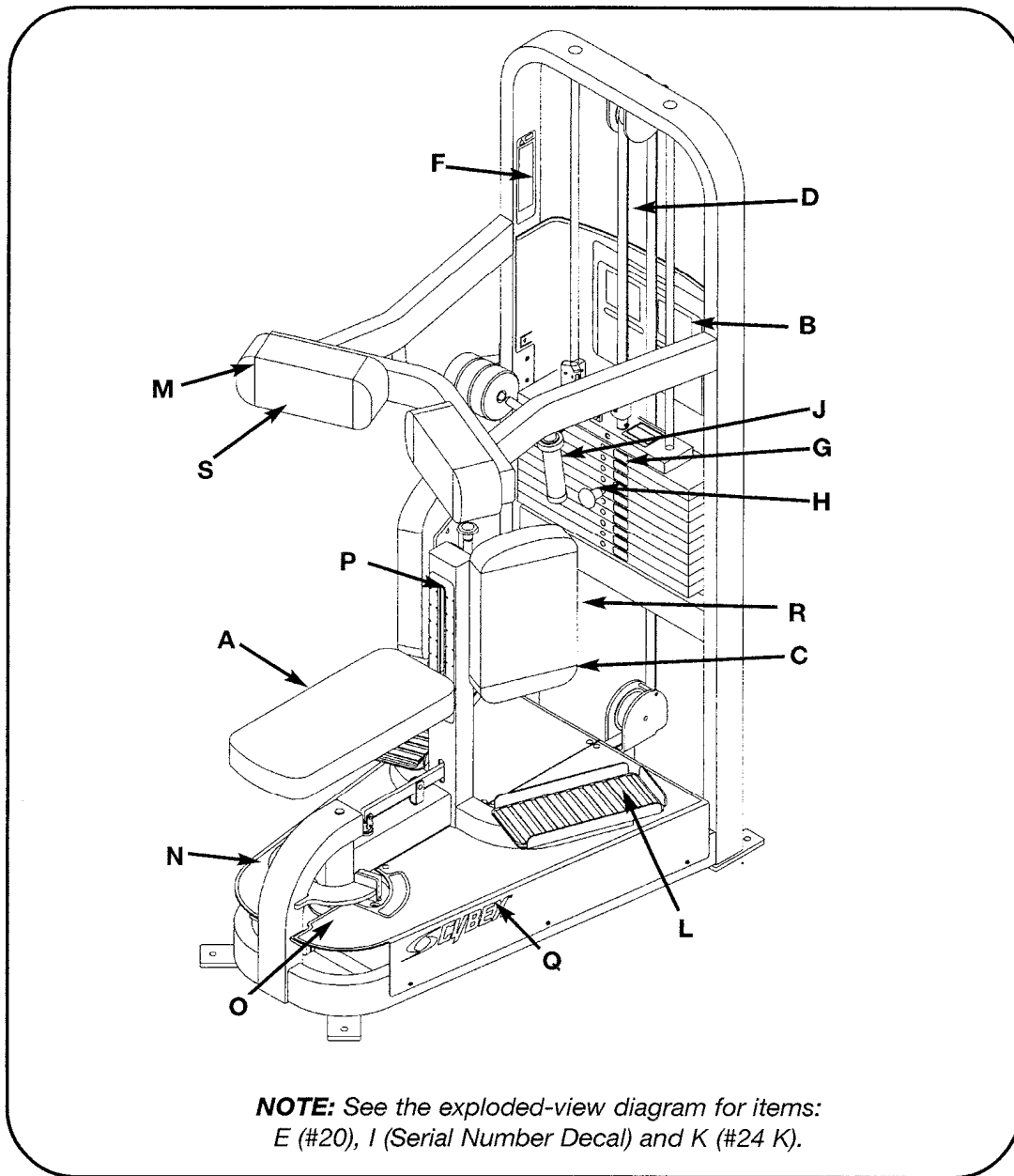

NOTE: See the exploded-view diagram for items:
E (#20), I (Serial Number Decal) and K (#24 K).

DESCRIPTION	PART NO.	DESCRIPTION	PART NO.
A. Seat Cushion.....	4800-024	K. Caution Decal.....	4605-424
B. Placard Decal.....	4715-338	L. Non-Slip	4710-321
C. Knee Cushion.....	4800-018	M. Chest Pad	4800-023
D. Belt 115" Long	GB000202	N. Non-Slip (Left Hand)	4715-339
E. Cybex Decal Blk/Plm	3900-391	O. Non-Slip (Right Hand) ...	4715-340
E. Cybex Decal Wht/Wht ..	3900-419	P. Seat Adjustment Decal .	5221-316
F. Warning Decal	4605-381	Q. Cybex Decal Blk/Plm	3900-390
G. Weight Plate Decal	4605-388	Q. Cybex Decal Wht/Wht ..	3900-415
H. Weight Selector Pin.....	BH030207	R. Wear Cover (Item C).....	4800-090
I. Serial Number Decal		S. Wear Cover (Item M)	4800-095
J. Grip	4605-510	T. Caution Decal.....	4520-362

4715 - Torso Rotation

ITEM	QTY	PART NO.	DESCRIPTION	ITEM	QTY	PART NO.	DESCRIPTION
1	1	01989	Single Connecting Link	35 A	1	4715-333	Left Guard
2	1	11040-440	Cybex Knob	35 B	1	4715-334	Right Guard
3	2	PR070001	Foot Pad 2.50 x 4.25	36	1	4715-335	Bar
4	1	4800-024	Seat Cushion	37	2	4715-336	Washer
5	1	4520-212	Seat Roller	38	1	4715-338	Placard Decal
6	2	4520-331	Roller	39	1	4715-339	Non-Slip (Left Hand)
7			Removed	40	1	4715-340	Non-Slip (Right Hand)
8	1	5221-316	Adjustable Seat Decal	41	1	4715-341	Detent Decal
9 A	2	4800-023	Chest Cushion w/Wear Cover	42	1	4715-342	Pivot Location Decal
9 B	2	4800-095	Wear Cover	43	1	4505-432	Guard
10	1	4701-021	Weight Stack Guide Rod Set	44			Not Used
10 A	2	4505-319	Weight Stack Guide Rod	45			Not Used
10 B	4	BR030214	Retaining Ring .625	46	4	BR030210	Retaining Ring 17 mm
10 C	2	HS407100	Spring Washer .65 x .79 x .062 T	47	2	BR030213	Retaining Ring 2.00 External
10 D	2	PN660200	Plastic Insert 1.00 Dia x 11 G	48			Not Used
10 E	2	PR060005	Weight Bumper	49	1	4715-346	Com Spring .72 x 1.50 L
11 A	2	4800-018	Knee Cushion w/Wear Cover	50			Removed 8/98
11 B	2	4800-090	Wear Cover	51	1	FB030232	Radial Brg 17 mm ID (Ext Race)
12			Not Used	52	2	FB130206	Flange Brg 2.00 x 2.25 x 1.00 L
13			Removed	53	2	FB130209	Flange Brg .375 x .50 x .125 L
14	4	4605-300	Belt Clamp	54	1	FB130210	Nyliner Bearing
15	1	4715-352	Pivot Shaft 13.505	55	115"	GB000202	Weight Stack Belt .95" Wide
16			Not Used	56	3	GP000209	Pulley Assembly 3.50
17	2	PR070003	Foot Pad 2.00 x 5.25	57	2	GP000212	Pulley Assembly 3.50
18	2	4605-550	Plug	58			Removed
19	1	4605-381	Warning Decal	59	2	HC702817	SHCS .375-16 x 1.00
20			Removed 3/03	60			Removed
20	1	3900-391	Cybex Decal 11.37 Vert. Blk/Plm	61			Removed 8/98
20	1	3900-419	Cybex Decal 11.37 Vert. Wht/Wht	62	7	HC702830	SHCS .375-16 x 2.50
21	1	4605-388	Weight Plate Decal 10-290	63	2	HC702834	SHCS .375-16 x 3.00
22			Not Used	64	6	HN704901	Nylon Locknut .375-16
23	4	4605-394	Belt Clamp	65	1	HP286715	Roll Pin .188 x .75
24	1	4701-030	Sliding Increment Weight Set	66			Removed
24 A	1	11040-216	Belt Clamp	67			Not Used
24 B	1	11040-301	Belt Clamp Insert	68			Not Used
24 C	3	4605-390	Increment Weight	69			Not Used
24 D			Removed 3/03	70	16	HT102214	Tap Screw #10-12 x .625 A (Phil)
24 E	1	BH030207	Weight Selector Pin	71			Removed 8/98
24 F	1	4701-001	Top Weight Guide	72	5	JC702820	SHCS .375-16 x 1.25
24 G	2	HC702817	SHCS .375-16 x 1.00	73	2	4605-510	Grip 4.75 Long
24 H	2	HC702828	SHCS .375-16 x 2.25	74	2	PU060204	Bumper
24 I	4	HN704901	Nylon Locknut .375-16	75			Not Used
24 J	4	HS347600	Washer, SAE .375	76	3	PP090202	Plastic Insert 1.5 x 3.0 x 11 G
24 K	3	HY740000	Set Screw	77	2	PP090206	Plastic Insert
24 L	1	4605-424	Caution Decal	78	2	PP090210	Plastic Insert 2.00 sq x 10-14 G
24 M	1	4700-240	Weight Mount	79	4	HC702822	SHCS .375-16 x 1.50
24 N	2	4700-318	Increment Weight Rod	80			Not Used
24 O	1	4700-319	Frame Mount Increment Weight	81	4	HN784000	Hex Nut .500-13
24 P	1	FB130208	Bearing Sleeve .68 x .81 1.00 L	82			Removed 3/03
24 Q	2	4700-321	Rubber Washer	82	1	3900-390	Cybex Decal 1.57 Horiz. Blk/Plm
24 R	2	JC702820	SHCS .375-16 x 1.25	82	1	3900-415	Cybex Decal 1.57 Horiz. Wht/Wht
24 S	2	HS348300	Split Lockwasher .375	83	1	4701-302	VR2 Weight Stack Instr. (not shown)
24 T	1	4700-239	Top Weight	84	1	51198	Strength Warranty Sheet (not shown)
24 U	3	HC702816	SHCS .375-16 x .875	85	2	HF449063	Tube Insert
25			Removed	86	1	4715-358	Belt Guide
26	2	4710-321	Non-Slip	87	1	FB030240	Bearing Tapered Roller
27	1	4715-200	Frame	88	1	4520-213	Bracket
28	1	4715-201	Pivot	89	1	4520-362	Caution Decal
29	1	4715-202	Seat	90	2	HS347700	Washer USS .375
30	1	4715-203	Cam	91	2	JC700412	BHSCS .375-16 x .50
31	1	4715-204	Pulley Bracket	92	9	4000C101	Stack Weight 4 x 18 (not shown)
32	1	4715-324	Rod	93	2	11090-376	Handle Grip Ring
33	1	4715-325	Linkage Bar	94	2	JC620422	BHSCS .250-20 x 1.50
34	1	4715-345	Detent Pin	95	4	JS347400	Internal Tooth Lockwasher
35	1	4715-333S	Guard Set	96	1	4715-372	Belt .965 Wide Steel Cord x 54"

TORSO ROTATION - 4715

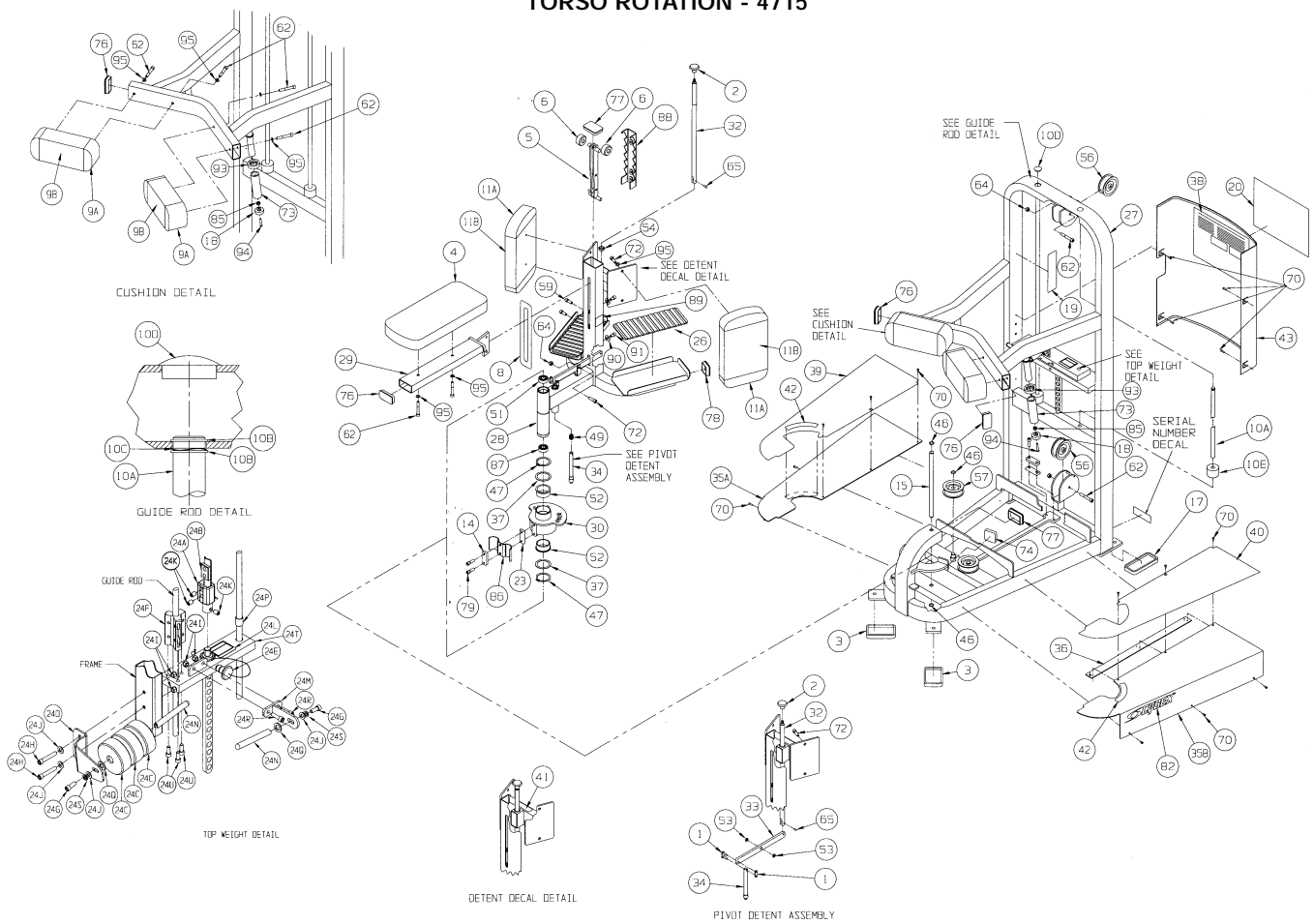

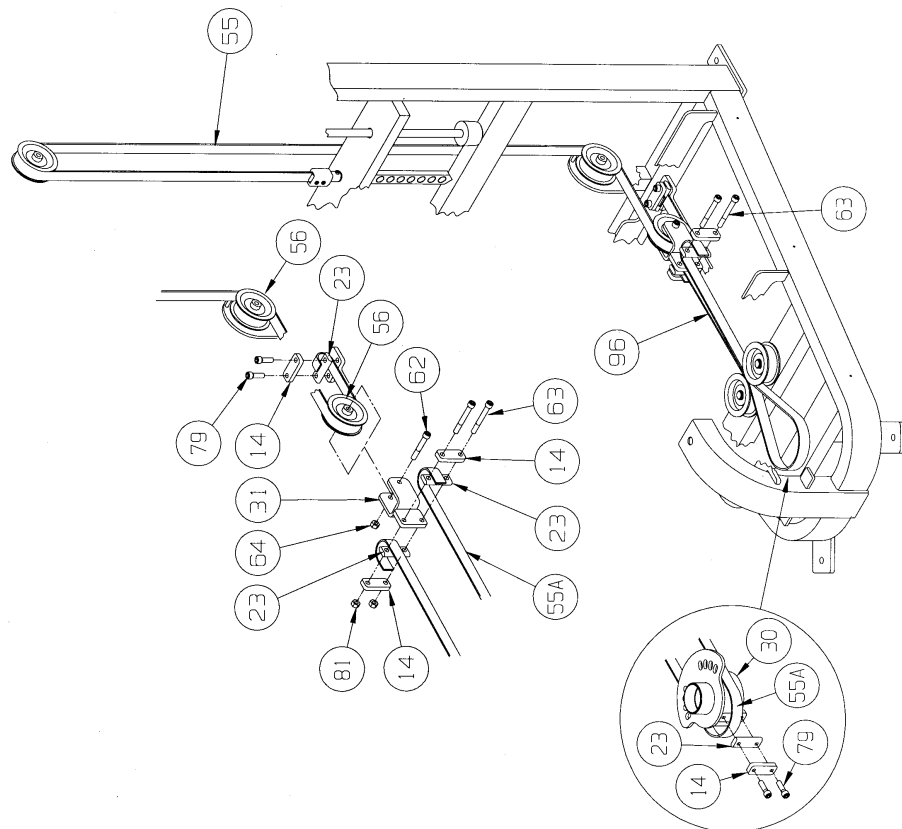

BELT ROUTING DETAIL



10 Trotter Drive Medway, MA 02053 • 508-533-4300 • FAX 508-533-5183
www.cybexinternational.com • Techhelp@cybexintl.com • techpubs@cybexintl.com