



Cybex Treadmill Product Number 770T
Owner's Manual
Cardiovascular Systems
Part Number LT-22983-4 M

Table of Contents

Safety

| | |
|--------------------------------------|----|
| Safety Guidelines and Practices..... | 4 |
| Power Cord Information..... | 4 |
| Voltage Information..... | 5 |
| Important Safety Instructions..... | 5 |
| Warning Decals..... | 7 |
| Label Placement..... | 9 |
| Emergency Stop Key (e-stop)..... | 10 |

Assembly

| | |
|---|----|
| Specifications..... | 12 |
| Choosing and Preparing a Site..... | 13 |
| Environment..... | 14 |
| Electrical Power Requirements..... | 14 |
| Verify parts list shown below..... | 15 |
| Tools Required..... | 17 |
| Assembly Procedure..... | 17 |
| Setup..... | 31 |
| A/V Configuration and FM Radio Presets..... | 33 |
| E3 View Monitor Controls..... | 38 |
| E3 View Monitor Setup..... | 39 |
| Testing Operation..... | 48 |

Operation

| | |
|---|----|
| Intended Use..... | 50 |
| Terms Used..... | 50 |
| Console Display..... | 51 |
| User Control Symbols Used..... | 52 |
| CardioTouch Symbols Used..... | 53 |
| CardioTouch Screen and User Controls..... | 55 |
| Quick Operation Guide..... | 56 |
| Detailed Operation Guide..... | 57 |
| Stopping the Treadmill..... | 59 |
| Safety Sentry..... | 60 |
| Workout Selection..... | 60 |
| Data Readouts..... | 62 |
| Heart Rate Indicator..... | 62 |
| Meaning of % Grade..... | 63 |
| Fan Control..... | 63 |
| E3 View Monitor Screen Options..... | 63 |
| iPod/iPhone Functions..... | 64 |
| CSAFE Port..... | 65 |

Maintenance

| | |
|-------------------------------|----|
| Warnings..... | 66 |
| Clean Unit..... | 66 |
| Vacuum Motor Bay..... | 67 |
| Running Belt..... | 68 |
| Other Maintenance..... | 70 |
| E3 View Monitor..... | 71 |
| Service Wheel (optional)..... | 71 |
| Service Schedule..... | 73 |

Customer Service

| | |
|--|----|
| Product Registration..... | 75 |
| Contacting Service..... | 75 |
| Ordering Parts..... | 75 |
| Return Material Authorization (RMA)..... | 76 |
| Damaged Parts..... | 76 |

Appendix - Workout Overviews

| | |
|-------------------------|-----|
| Speed Bump..... | 77 |
| Rollers..... | 78 |
| Hills..... | 79 |
| Peaks..... | 80 |
| Hill Interval 1:1..... | 81 |
| Hill Interval 1:2..... | 82 |
| Hill Interval 1:3..... | 83 |
| Interval Plus..... | 84 |
| Heart Rate Control..... | 85 |
| Gerkin Protocol..... | 87 |
| Army..... | 88 |
| Air Force..... | 90 |
| Navy < 5K..... | 95 |
| Navy > 5K..... | 98 |
| Marines Sea Level..... | 101 |
| Marines > 4.5K..... | 102 |
| One Mile Test..... | 103 |

Cybox® and the Cybox logo are registered trademarks of Cybox International, Inc. Polar® is a registered trademark of Polar Electro Inc. iPod and iPhone are trademarks of Apple Inc., registered in the U.S. and other countries. Safety Sentry™ is a registered trademark of Cybox International, Inc.

DISCLAIMER: Cybox International, Inc. makes no representations or warranties regarding the contents of this manual. We reserve the right to revise this document at any time or to make changes to the product described within it without notice or obligation to notify any person of such revisions or changes.

© Copyright 2015, Cybox International, Inc.

10 Trotter Drive, Medway, MA 02053 • 888-462-9239 • 508-533-4300 • FAX 508-533-5183

www.cyboxintl.com • LT-22983-4 M • September 2015

FCC Compliance Information

Changes or modifications to this unit not expressly approved by the party responsible for compliance could void the user's authority to operate the equipment.

This equipment has been tested and found to comply with the limits for a Class A digital device, pursuant to part 15 of the FCC Rules. These limits are designed to provide reasonable protection against harmful interference when the equipment is operated in a commercial environment. This equipment generates, uses, and can radiate radio frequency energy and, if not installed and used in accordance with the instruction manual, may cause harmful interference to radio communications. Operation of this equipment in a residential area is likely to cause harmful interference in which case the user will be required to correct the interference at his own expense.

Modifications not expressly approved by the manufacturer could void the user's authority to operate the equipment under FCC rules.

Safety

Safety Guidelines and Practices

 Read the Owner's Manual carefully before assembling, servicing, or using the equipment. Owner must comply with all safety guidelines in this manual. It is also the owner's responsibility to instruct users on the safe and proper operation of the equipment and to properly display any and all warning labels and instructional placards. All users should read these labels and placards before using equipment.

WARNING

Serious injury or death could occur if the following safety precautions and instructions are not followed.

Power Cord Information

This treadmill must be grounded. If it should malfunction or break down, grounding provides a path of least resistance for electric current to reduce the risk of electric shock. This product is equipped with a cord having an equipment-grounding conductor and a grounding plug. The plug must be plugged into an appropriate outlet that is properly installed and grounded in accordance with all local codes and ordinances.

WARNING

Shock and electrocution hazard.









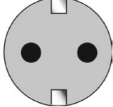

- Connect unit to a grounded outlet.
- Do not use voltage adapter or extension cord.

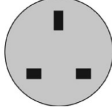
NOTICE

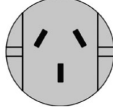
Cybex is not responsible for injuries or damages as a result of cord or plug modification.

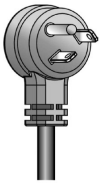
- Verify voltage requirements of unit match local voltage requirements.
- Verify unit outlet is the same configuration as the plug.

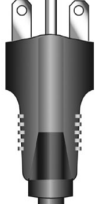
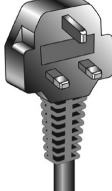
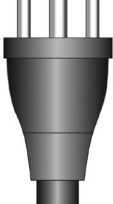
Power cord configurations

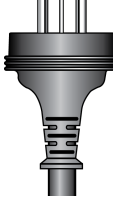
| | | | | | | |
|---|---|---|---|--|---|---|
|  |  |  |  |  |  |  |
|  |  |  |  |  |  |  |
| 115 VAC | Euro Plug | 220 VAC | UK 230 VAC | Danish | Australia | Chinese |

| | | | | | | |
|-----------|---------|-----------|---------|----------|-------------|-------------------------------|
| NEMA 5-20 | CEE 7/7 | NEMA 6-15 | BS 1363 | 107-2-D1 | AS/NZS 3112 | GB 2099-1 and GB 1002-1 |
|-----------|---------|-----------|---------|----------|-------------|-------------------------------|

Voltage Information

Before plugging the power cord into an electrical outlet, verify that the voltage requirements for the site match the voltage of the treadmill that has been received. The power requirements for the unit include a grounded, dedicated circuit, rated for one of the following:

- 100 VAC, 50/60 Hz, 20A
- 115 VAC, 50/60 Hz, 20A
- 208 VAC, 60 Hz, 15A
- 220 VAC, 60 Hz, 15A
- 230 VAC, 50 Hz, 13A, UK

See the front warning decal for the voltage requirements of the treadmill.

Important Safety Instructions

(Save These Instructions)

⚠️ WARNING

Shock and electrocution hazard.

- Unplug unit and let sit 10 minutes before cleaning or performing maintenance.
- Electrical charge can remain in unit after unplugging.
- Keep water and liquids away from electrical parts.

User Safety Precautions

Prior to use:

- Obtain a medical exam before beginning any exercise program.
- Obtain instruction before using.
-  Read and understand warning labels.
- Read and understand emergency stop procedures.
- Maximum user weight is 400 lbs. (180 kg).
- Inspect unit. If damaged, notify floor staff. DO NOT USE.
- Place your feet on the two top steps when starting or stopping the treadmill.
- Clip E-STOP lanyard to clothing.
- Do not remove this label. Replace if damaged or illegible.

During use

- Do not use for stretching and do not attach straps or other devices.
- Do not allow children 12 or younger to be on or near machine.
- Stop exercise if feeling faint, dizzy, or have pain.
- Use the handrails for support and to maintain balance.

- Keep all body parts, clothing, and accessories, clear of moving parts.
- Wait until running belt comes to a complete stop before getting off.

Facility Safety Precautions

It is the sole responsibility of the user/owner or facility operator to ensure that regular maintenance is performed.

- Enforce all user and safety precautions.
- Read and understand the Owner's Manual completely before assembling, servicing or using unit.
- Verify all users are properly trained on using the equipment.
- Do not use unit outdoors.
- Verify that each unit is setup, leveled and operated on a solid level surface. Do not install equipment on an uneven surface. Do not operate in recessed areas or on plush carpet.
- Verify there is enough room for safe access and operation of unit.
- Instruct all users on how to clip the e-stop clip onto their clothing and carefully test it prior to using the treadmill.
- Instruct all users to use caution when mounting and dismounting the treadmill.
- Use a dedicated line when operating the treadmill. A dedicated line requires one circuit breaker per unit.
- Connect the treadmill to a properly grounded outlet only.
- DO NOT operate electrically powered treadmills in damp or wet locations.
- Keep the running belt clean and dry at all times.
- DO NOT leave the treadmill unattended when plugged in and running.
 - 👉 **Note:** Before leaving the treadmill unattended, always wait until the treadmill comes to a complete stop and is level. Then, turn all controls to the STOP or OFF position and remove the plug from the outlet. Remove the e-stop key from the treadmill.
- Immobilize the treadmill (when not in use) by removing the e-stop key.
- Inspect the treadmill for worn or loose components before each use. Do not use until worn or damaged parts are replaced.
- Stop and place the treadmill at 0 degrees incline (level) after each use.
- Maintain and replace worn parts regularly. Refer to "Preventive Maintenance" section of Owner's Manual.
- DO NOT operate the treadmill if: (1) the cord is damaged; (2) the treadmill is not working properly or (3) if the treadmill has been dropped or damaged. Seek service from a qualified technician.
- DO NOT place the cord near heated surfaces or sharp edges.
- DO NOT use the treadmill outdoors.
- DO NOT operate the treadmill around or where aerosol (spray) or where oxygen products are being used.
- Ensure all users wear proper footwear on or around all Cybex equipment.
- Disconnect power before servicing.
- DO NOT attempt repairs, electrical or mechanical.
Seek qualified repair personnel when servicing. If you live in the USA, contact Cybex Customer Service at 888-462-9239. If you live outside the USA, contact Cybex Customer Service at 508-533-4300.
- Use Cybex factory parts when replacing parts on the treadmill.

- DO NOT modify the treadmill in any way.
- DO NOT use attachments unless recommended for the treadmill by Cybex.

Warning Decals

Warning labels indicate a potentially hazardous situation that could result in serious injury or death if the precautions are not observed.

Caution labels indicate a potentially hazardous situation that could result in serious injury or damage to machine if the precautions are not observed.

See Contacting Service to replace any worn or damaged labels.

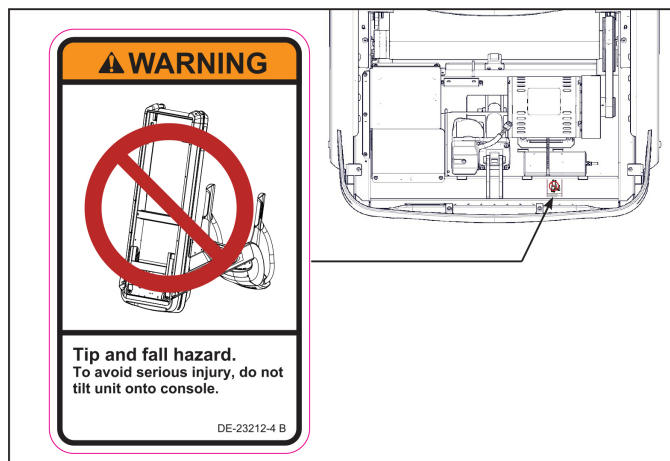
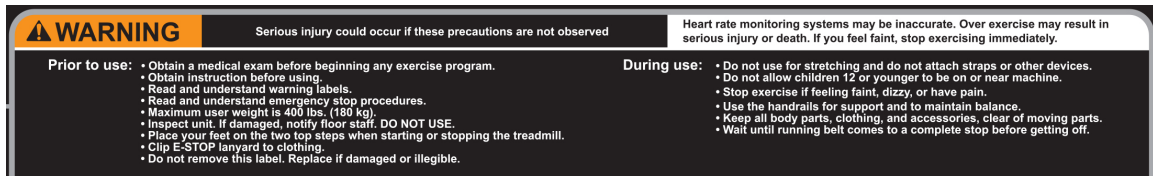
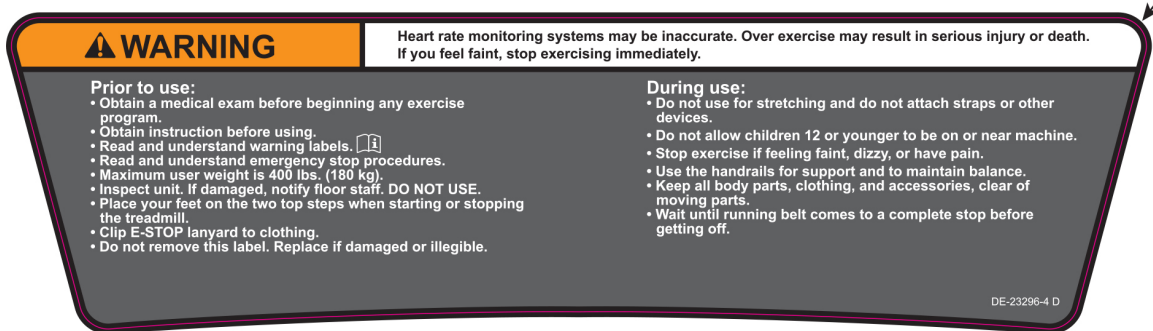
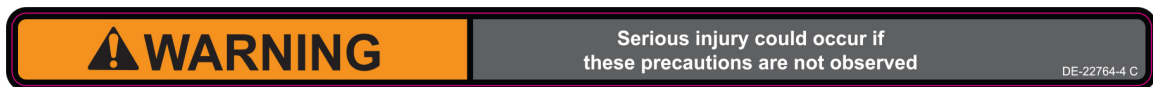



Label Placement

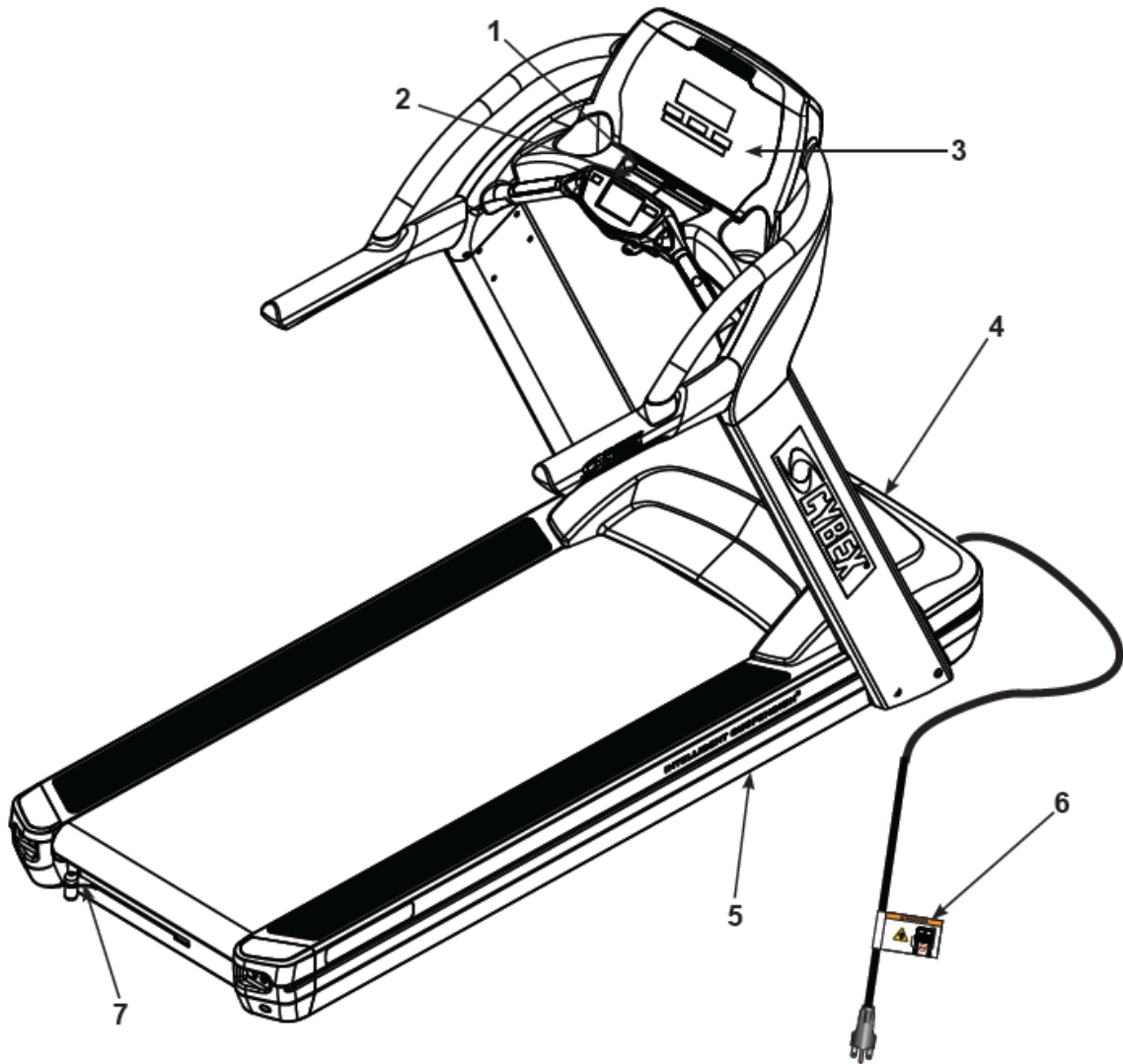

| | | |
|---|------------|---------------------------------------|
| 1 | DE-22764-X | Decal, Warning upper, console |
| 2 | DE-23296 | Decal, Warning lower, console |
| 3 | DE-23080-4 | Decal, Warning, Upper Display, Canada |
| 4 | DE-22910 | Decal, Motor Cover, 115 VAC |
| 4 | DE-23079 | Decal, Motor Cover, 230 VAC |
| 5 | DE-23212-4 | Label, Warning, Do not tilt |
| 6 | DE-23098 | Decal, Power Cord |
| 7 | DE-25047-4 | Decal, lever, service wheel |

Emergency Stop Key (e-stop)

The e-stop key functions as an emergency stop. In an emergency situation, the e-stop key disengages from the console and the treadmill will come to a stop. Before using the treadmill, clip the e-stop key as described below.

1. Compress the spring and clip the e-stop clamp to your clothing.

Ensure the clip engages enough clothing so it does not fall off in an emergency situation. Be sure the string is free of knots and has enough slack for you to workout comfortably with the e-stop key in place.

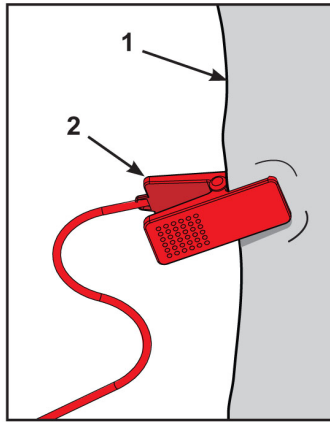

| | Description | Qty. |
|---|-------------|------|
| 1 | Clothing | 1 |
| 2 | Clip | 1 |

2. Without falling off the treadmill, carefully step backward until the e-stop pulls out of the console. If the e-stop clip falls off your clothing then the test has failed. Reclip the e-stop clip to your clothing and repeat this step.

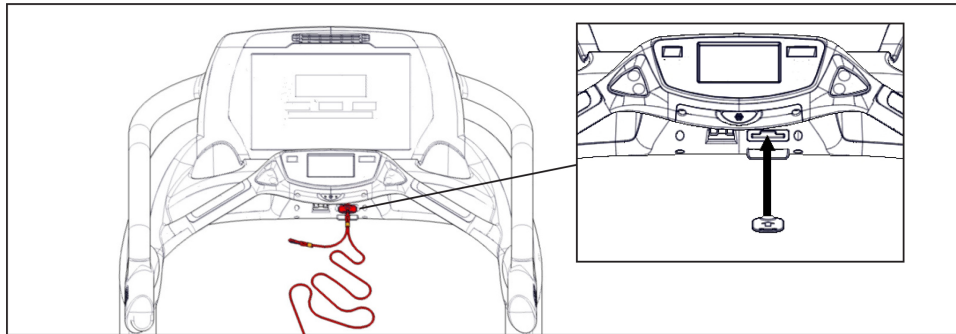

3. Replace the e-stop key.
4. The treadmill is now ready to be used. Ensure the e-stop clip is secured to your clothing at all times during use.

5. After use, remove the e-stop key from the treadmill.

The e-stop key can be removed to help prevent unauthorized use. Refer to the Stopping the Treadmill section in the Operation chapter for more information about the e-stop key.

When not in use store the e-stop clip on the storage tab located on the lower cover.

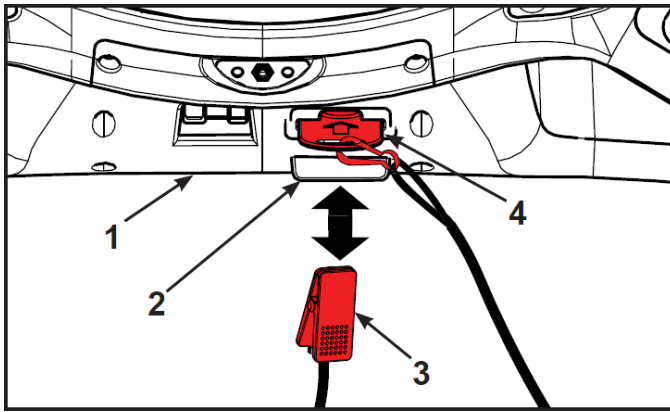

| | |
|---|-------------|
| 1 | Lower cover |
| 2 | Storage tab |
| 3 | E-Stop clip |
| 4 | E-Stop |

Assembly

Specifications

| | |
|---------------------|---|
| Assembled Length | 84" (213 cm) |
| Assembled Width | 35.6" (90.5 cm) |
| Assembled Height | 62.5"(159 cm) |
| Weight of Product | 410 lbs. (186 kg) |
| Shipping Weight | 440 lbs. (200 kg) |
| Incline Levels | 0-15 % grade |
| Speed Range | 0.5 to 12.4 mph (0.8 to 20.0 kph) in 0.1 mph or 0.1 kph increments |
| Workouts | Quick Start and nine workouts with user orientated goal (Time, Distance or Calories). Advanced programming includes, Gerkin protocol and all Military Protocols. |
| Console Features | Upper console: LED or E3 View Monitor. Displays - BPM, Calories, Cal/Hr, Distance, MET, Pace, Time, Watts, and Weight. Lower console: Two numeric displays for incline and speed. Accessory trays and water bottle holder. |
| Heart Rate Features | Built-in 5 KHz wireless heart rate receiver (transmitter not included) and contact heart rate monitoring. |
| Maximum User Weight | 400 lbs. (180 kg). |
| Power Rating | 115 VAC 50/60 Hz. or 208/230 VAC 50/60 Hz. |
| Options | E3 View Monitor, Wireless audio receiver, iPod/iPhone compatibility. |

Top View 770T

Dimensions

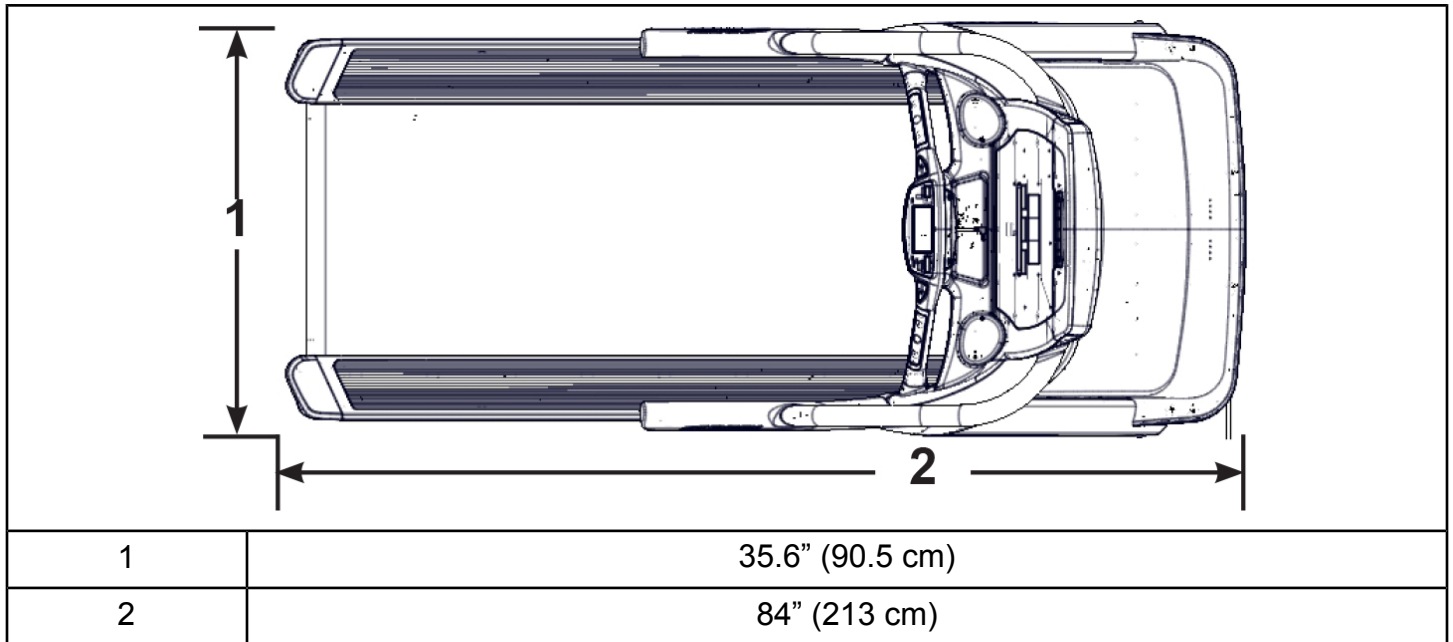

Choosing and Preparing a Site

Before assembling the unit, verify the chosen site meets the following criteria:

- Area is well lit and well ventilated.
- Surface is structurally sound and properly leveled.
- Free area for access to unit and emergency dismount. Minimum clearance is 19.7 inches (0.5 meters) on the sides of the unit and 78.7 inches (2.0 meters) behind the unit.
- Adjacent units may share the free area.

Free area

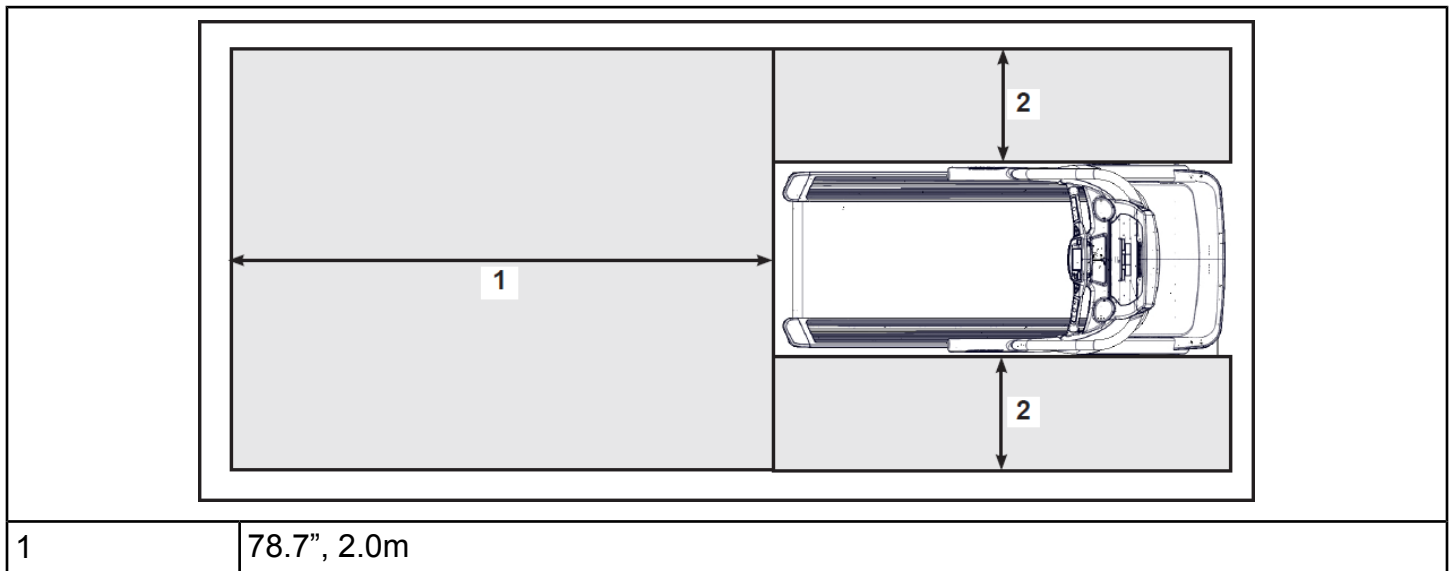

| | |
|---|-------------|
| 2 | 19.7", 0.5m |
|---|-------------|

It is the responsibility of the facility owner/owner of the equipment to ensure that there is appropriate clearance around each machine to allow for safe use and passage.

In compliance with the ADA (American Disabilities Act) there must be clear floor space of at least 30 by 48 inches and be served by an accessible route for at least one of each type of exercise equipment. If the clear space is enclosed on three sides (e.g., by walls or the equipment itself), the clear space must be 36 by 48 inches.

All other machines must have a clear floor space of 23" for all access point on the machine.

The dimensions stated in the assembly instructions of this manual include the maximum foot print (in use) dimensions.

Minimum clearance of 12" (30 cm) between units for proper wireless heart rate signal operation.

Environment

Humidity and Static Electricity

The unit is designed to function normally in an environment with a relative humidity range of 30% to 75%. The unit can be shipped and stored in a relative humidity range of 10% to 90%.

Climatic dry air may cause static electricity. During workout, user may experience a shock due to build up of static electricity on the body and the discharge path of the unit. If static electricity is experienced, increase humidity to a comfortable level through the use of a humidifier.

Do not install, use or store the unit in an area of high humidity, such as in the vicinity of a steam room, sauna, indoor pool or outdoors. Exposure to extensive water vapor, chlorine and/or bromine could adversely affect the electronics as well as other parts of the unit.

Temperature

The unit is designed to function normally in an environment with an ambient temperature range of 50° F (10° C) to 104° F (40° C). The unit can be shipped and stored in an environment with an ambient temperature range of 32° F (0° C) to 140° F (60° C).

Electrical Power Requirements

The power requirements for this treadmill are a grounded, dedicated circuit rated for one of the following:

- 100 VAC, 50/60 Hz, 20A
- 115 VAC, 50/60 Hz, 20A
- 208 VAC, 60 Hz, 15A
- 220 VAC, 60 Hz, 15A
- 230 VAC, 50 Hz, 13A, UK

⚠ WARNING

Shock and electrocution hazard.

- Connect unit to a grounded outlet.
- Do not use voltage adapter or extension cord.

Verify the unit is connected to an outlet having the same configuration as the plug.

Verify connection is a grounded circuit. Do not use a ground-plug adapter to adapt the 3-prong power cord to a non-grounded electrical outlet.

Verify power supply is compliant with local building codes.

Verify parts list shown below

| Item | Quantity | Part Number | Description |
|------|----------|-------------|--|
| 1 | 1 | Varies | Base assembly |
| 2 | 1 | Varies | Console assembly |
| 3 | 1 | FM-22900 | Upright, Left |
| 4 | 1 | FM-22901 | Upright, Right |
| 5 | 1 | Varies | Power Cord |
| 6 | 1 | CN-22747 | CSAFE Coupler (optional) |
| 7 | 1 | Varies | Power Supply |
| 8 | 2 | FS-23044 | Clamp |
| 9 | 2 | HS-21672 | Screw, #8-32 x 1/2" |
| 10 | 1 | AX-23019 | Hardware pack |
| 11 | 1 | LT-22983-X | Owner's Manual |
| 12 | 1 | LT-22984 | Assembly poster |
| 13 | 1 | LT-23016-4 | Warranty sheet |
| 14 | 1 | AW-23836 | Cable, 6', Coax (E3 View Monitor option) |

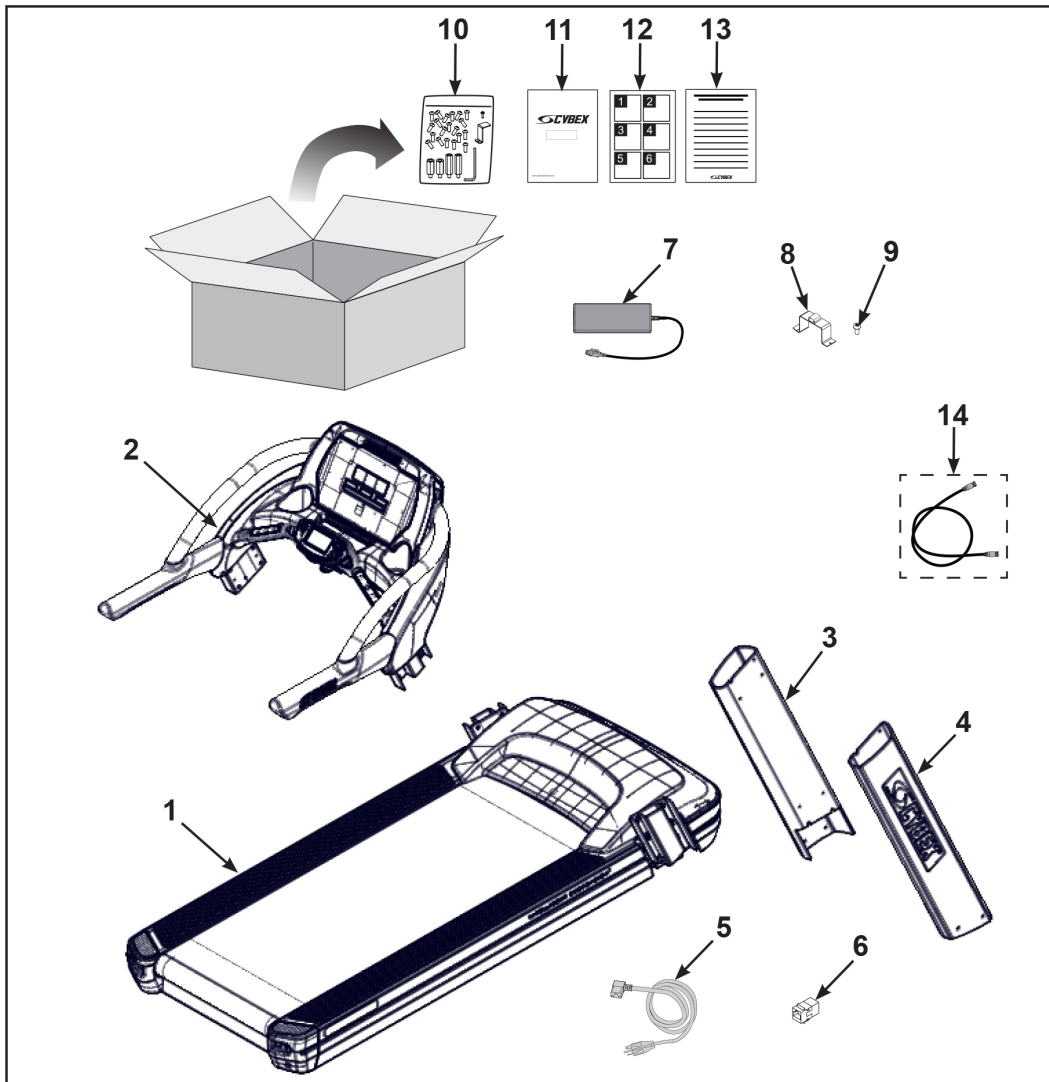

Hardware

| Item | Quantity | Part Number | Description |
|------|----------|-------------|---------------------------------------|
| 9 | 1 | HS-21672 | Screw, #8-32 x 1/2" |
| 15 | 16 | HS-22651 | Bolt, 3/8-16 .75", BHCS, ZN |
| 16 | 4 | HS-16929 | Bolt, Whiz Lock, 3/8-16 x .625", HXHD |
| 17 | 2 | FM-22778 | Standoff, M-F, 3/8-16" Thread, Short |
| 18 | 2 | FM-22779 | Standoff, M-F, 3/8-16" Thread, Long |
| 19 | 1 | HX-00440 | Allen wrench, 7/32" |
| 20 | 1 | FS-23071 | Bracket, Power Cord |
| 21 | 4 | HX-21519 | Connector, Plastic |

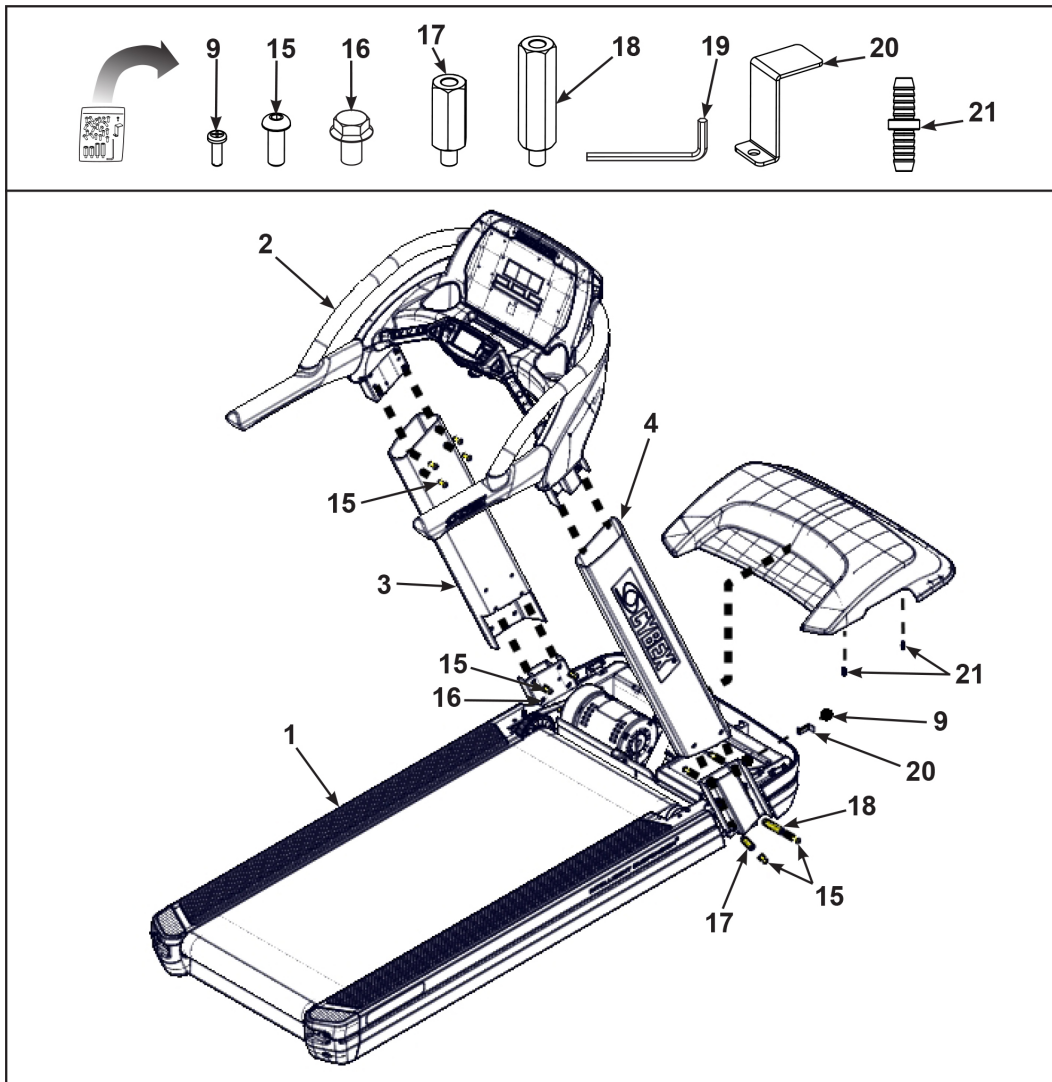

Tools Required

- Phillips screwdriver
- Long 3/8" drive socket extension
- 3/4" Open end wrench
- 7/32" Allen wrench (included)
- 9/16" Open end wrench
- 14 mm Open end wrench

Assembly Procedure

Two people will be required for this procedure.

 Read and understand all instructions thoroughly before assembling this unit. Check all items carefully. If there is damage, see the Customer Service section of this manual for proper procedure to return, replace, or reorder parts.

The words "left" and "right" denote the user's orientation.

Verify you have received the correct package

1. Read box label to verify the model number and voltage (optional) match what was ordered.
2. Verify paint color matches what was ordered.

Lift and move the treadmill

⚠WARNING

Heavy equipment.

- At least two people must lift, move or assemble unit.
- Use safe lifting methods.

1. Take note of doorway widths in facility before assembly. The base is 32.5" (83 cm) wide. With uprights installed the width is 35.6" (90.5 cm).
2. At least two people should lift and move the treadmill to a level location where you intend to leave it. Use proper lifting methods.

Remove shield

1. Loosen, but do not remove the two front cover screws securing the motor cover using a Phillips screwdriver.

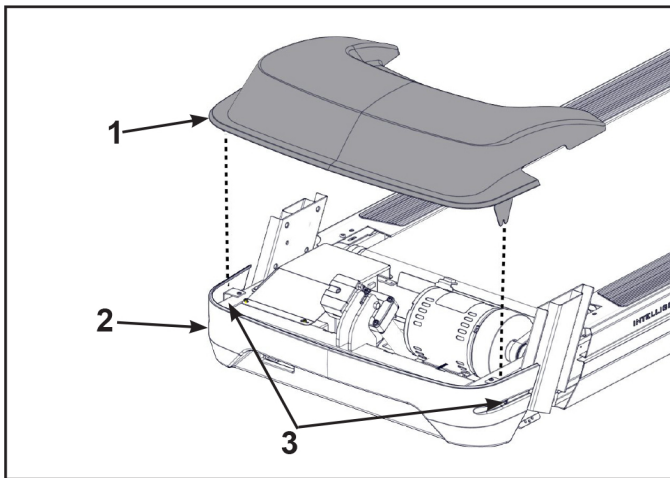

| | Description | Qty. |
|---|-------------|------|
| 1 | Motor cover | 1 |
| 2 | Front cover | 1 |
| 3 | Screws | 2 |

2. Remove motor cover by lifting vertically.

- Loosen but do not remove the seven screws securing the shield to the base using a Phillips screwdriver.

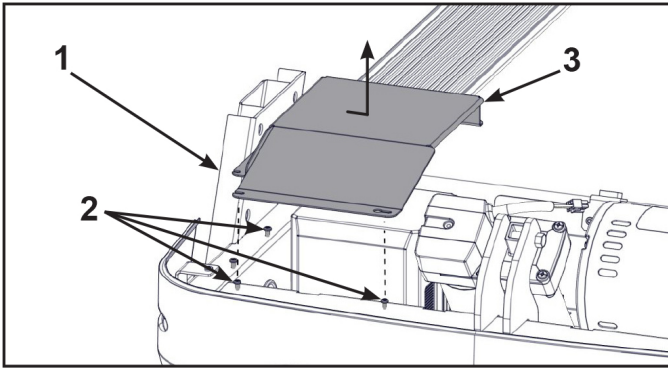

| | Description | Qty. |
|---|-------------|------|
| 1 | Base | 1 |
| 2 | Screws | 7 |
| 3 | Shield | 1 |

- Remove shield by sliding sideways and then vertically off of base.

Route power cord

Decide whether you will plug the power cord into a power outlet near the front of the treadmill or the back of the treadmill. Follow the corresponding routing procedure below. Do not plug the power cord into a power outlet at this time.

⚠ WARNING

Shock and electrocution hazard.

- Route power cord so it does not become damaged.
- Do not allow cord to be pinched or interfere with movement of treadmill.

Front routing: Skip to [Install uprights](#) on page 22.

Back routing:

- Remove the four screws securing the front cover to the base using a Philips screwdriver.

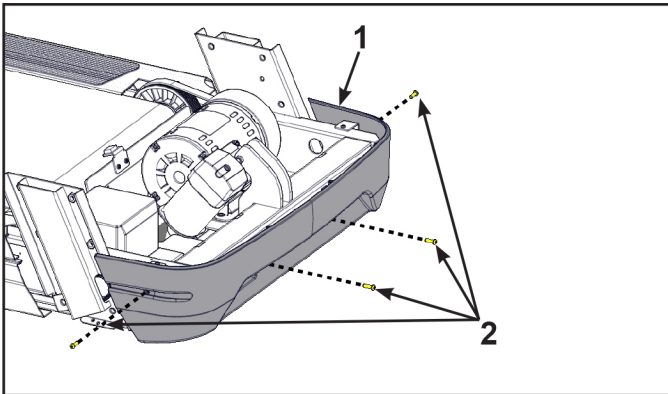

| | Description | Qty. |
|---|-------------|------|
| 1 | Front cover | 1 |
| 2 | Screws | 4 |

- Remove front cover.

3. Remove the two screws securing the right end cap using a Philips screwdriver.

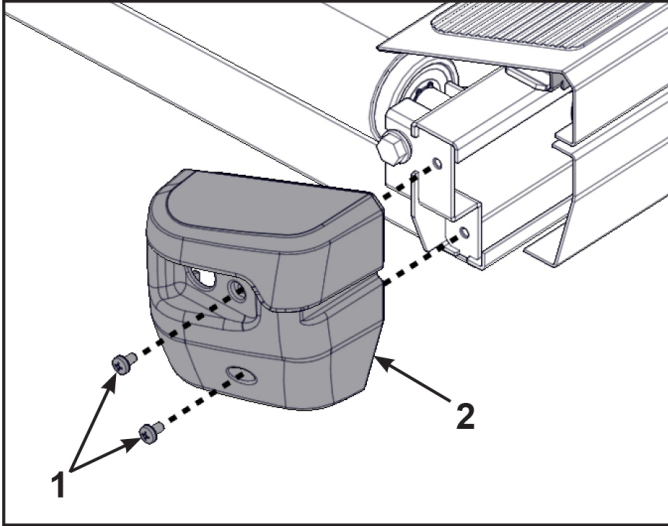

| | Description | Qty. |
|---|---------------|------|
| 1 | Screws | 2 |
| 2 | Right end cap | 1 |

4. Remove the right top step by inserting a long 3/8" drive socket extension into the right top step and prying backwards.

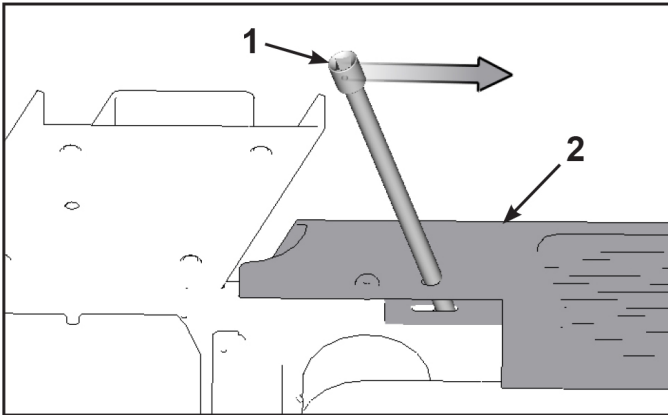

| | Description | Qty. |
|---|-----------------------------|------|
| 1 | 3/8" Drive Socket Extension | 1 |
| 2 | Right Top Step | 1 |

5. Remove the right top step.

6. Route the power cord through the hole in the upright support and behind the lower cover.

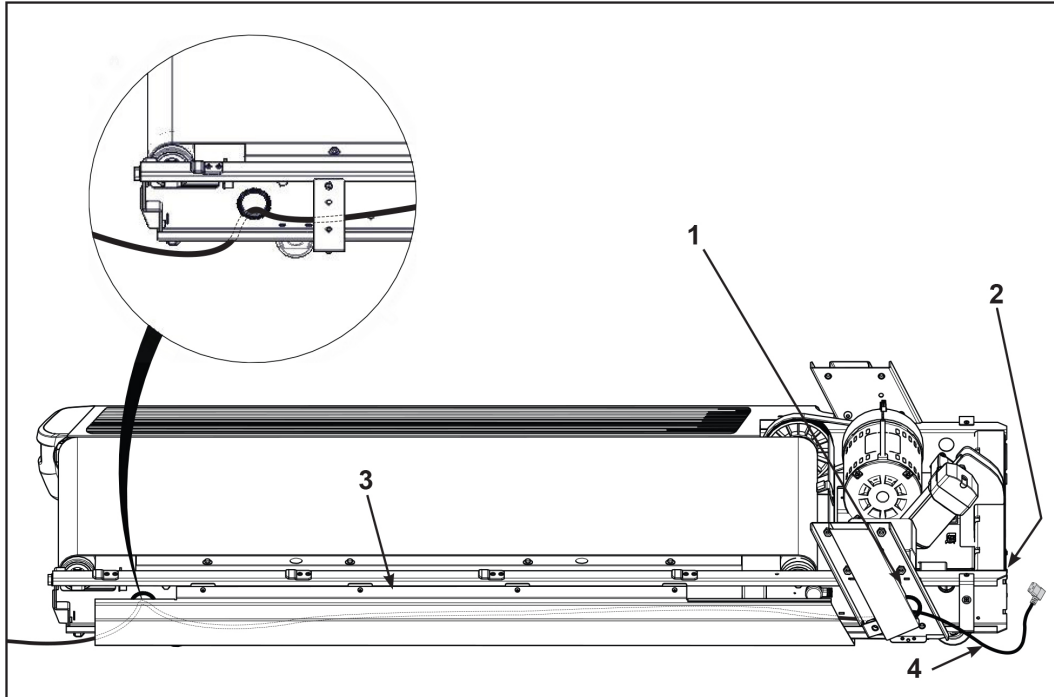

| | Description | Qty. |
|---|-------------------------|------|
| 1 | Hole in Upright Support | 1 |
| 2 | Power Cord Inlet | 1 |
| 3 | Lower Cover | 1 |
| 4 | Power Cord | 1 |

7. Adjust the power cord length entering the frame to allow for the power cord to be plugged into the power cord inlet. Do not plug the power cord in at this time.
8. Adjust the power cord length exiting the rear of the frame. Store extra power cord behind lower cover.
9. Install the right top step by placing in position and inserting a long 3/8" drive socket extension into the right top step.

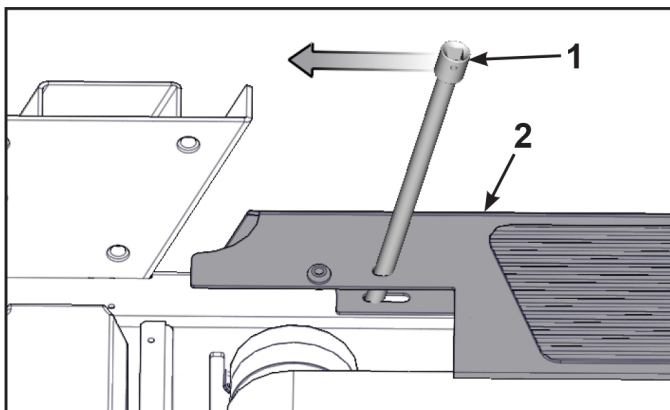

| | Description | Qty. |
|---|-----------------------------|------|
| 1 | 3/8" Drive Socket Extension | 1 |
| 2 | Right Top Step | 1 |

10. Pry the long 3/8" drive socket extension forwards to secure the right top step.
11. Using a Phillips screwdriver, install the two screws securing the right end cap.

Install uprights

1. Install the short and long standoffs to the right side of the base using a 3/4" open end wrench.

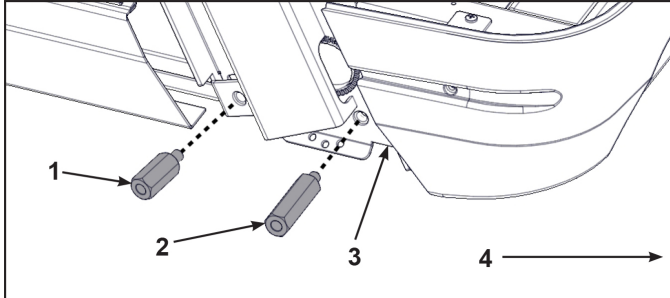

| | Description | Qty. |
|---|-----------------|------|
| 1 | Standoff, short | 1 |
| 2 | Standoff, long | 1 |
| 3 | Base | 1 |
| 4 | Front of unit | 1 |

2. Thread two bolts into the base by hand. Do not fully thread bolts into the base.

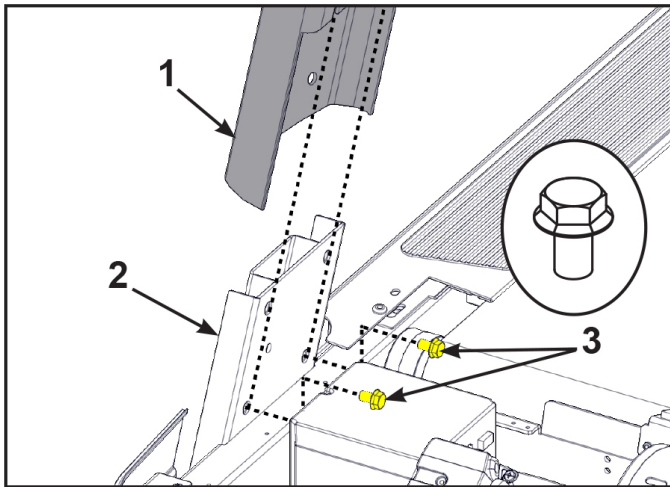

| | Description | Qty. |
|---|-----------------------|------|
| 1 | Upright (Right shown) | 1 |
| 2 | Base | 1 |
| 3 | Bolt, Whiz lock | 2 |

3. Place the right upright onto the base assembly and the bolts installed in the previous step.
4. Thread four bolts into the right upright by hand.

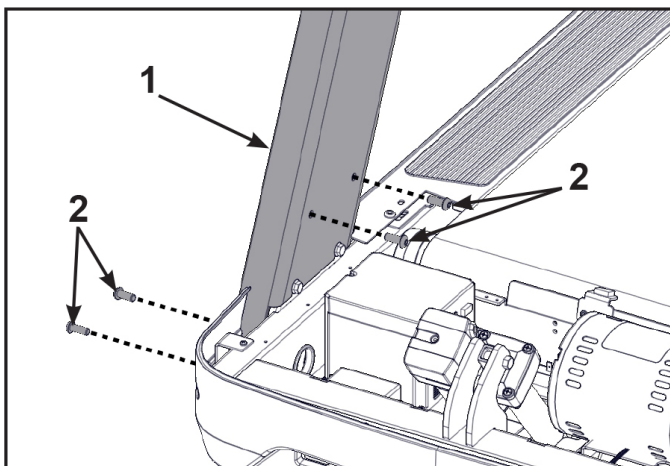

| | Description | |
|---|-----------------------|---|
| 1 | Upright (Right shown) | 1 |
| 2 | Bolt | 4 |

5. Repeat steps 1 through 4 for the left upright.

Install console assembly to the uprights

If unit includes optional A/V or other cables, follow same display cable procedure.

1. Thread one bolt, into the top back hole for each side of the console assembly by hand. Do not fully thread bolts into the console assembly.

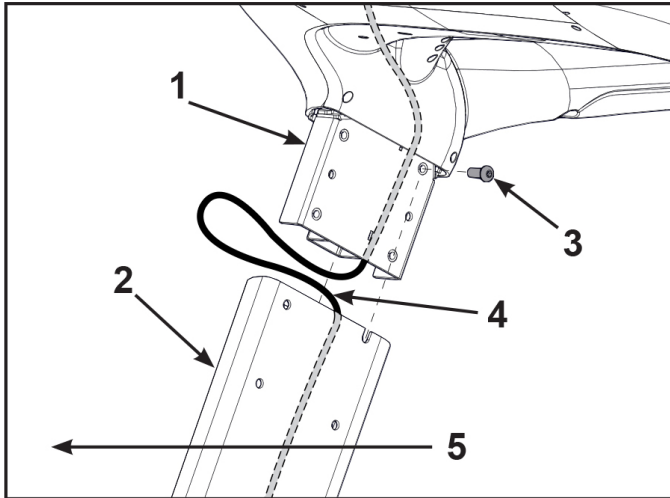

| | Description | Qty. |
|---|-----------------------|------|
| 1 | Console | 1 |
| 2 | Upright (Right shown) | 1 |
| 3 | Bolt | 1 |
| 4 | Display cable | 1 |
| 5 | Front of unit | 1 |

Do not pinch or damage display cable when installing console assembly.
Two people are required for the following two steps.

2. Insert the display cable into the top of the right upright until it exits the hole at the base of the right upright.

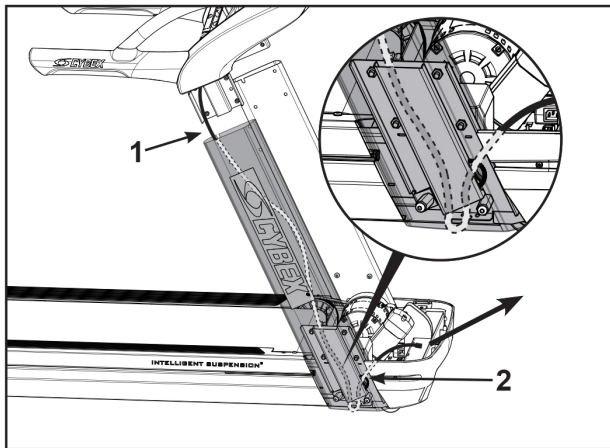

| | Description | Qty. |
|---|---------------------------|------|
| 1 | Insert display cable here | 1 |
| 2 | Hole | 1 |

3. Place the console assembly in position on the bolts installed in step 1 in the left and right uprights.

4. Thread six bolts into the remaining holes of the right upright and left upright.

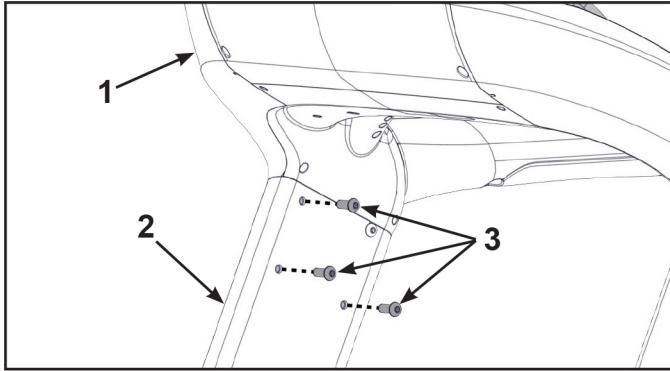

| | Description | Qty. |
|---|-----------------------|------|
| 1 | Console | 1 |
| 2 | Upright (Right shown) | 1 |
| 3 | Bolt | 3 |

5. Tighten all of the bolts using a 7/32" Allen wrench and 9/16" open end wrench.

Connect Display Cable

The display cable and CSAFE cable have the same connectors. The display cable is black, the CSAFE cable is red.

1. Route the cables under all other cables and towards the base plate.
2. Plug the display cable, located at the bottom of the upright assembly into the communication port of the controller.

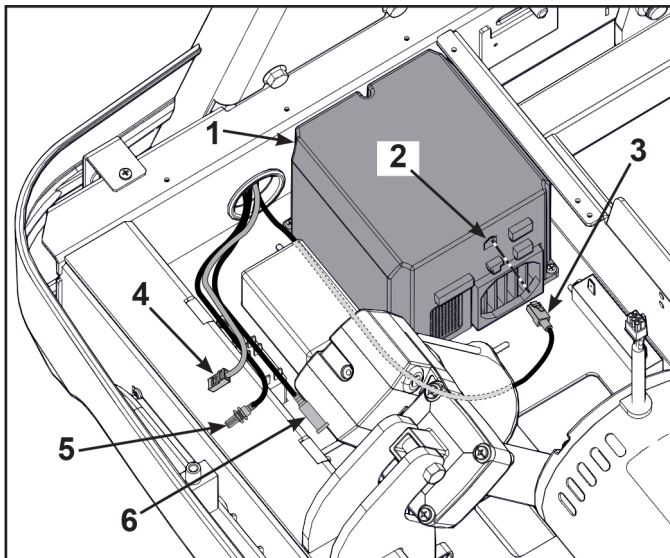

| | Description | Qty. |
|---|-----------------------------|------|
| 1 | Controller | 1 |
| 2 | Communication port | 1 |
| 3 | Display cable, Black | 1 |
| 4 | CSAFE cable, Red (optional) | 1 |
| 5 | Coax cable (optional) | 1 |
| 6 | Power supply cable | 1 |

Install power supply

1. Install the power supply to the base using clamp and screw.

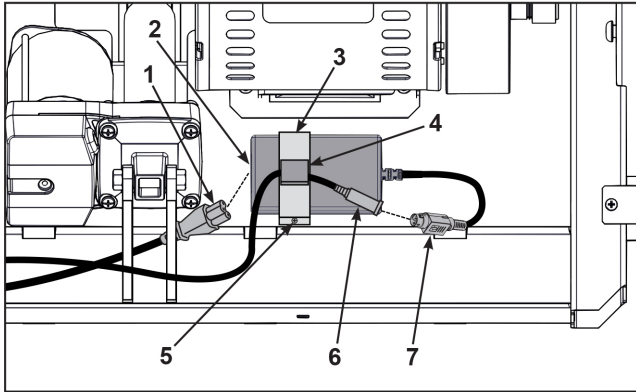

| | Description | Qty. |
|---|-----------------------------|------|
| 1 | AC Cord | 1 |
| 2 | Power Supply Inlet | 1 |
| 3 | Clamp | 1 |
| 4 | Gray Cable Clip | 1 |
| 5 | Screw | 1 |
| 6 | Console Cable DIN Connector | 1 |
| 7 | Power Supply Output | 1 |

2. Plug the AC cord into the power supply inlet.
3. Route console cable through the gray cable clip.
4. Connect the console cable's DIN connector to the power supply output. Make sure the two connectors snap firmly together and can not be pulled apart without pulling the sleeve back to release it.

Install optional A/V or CSAFE cables

1. Insert the CSAFE coupler into the mounting plate by hooking the lower tab into the mounting plate and snapping in the upper tab.

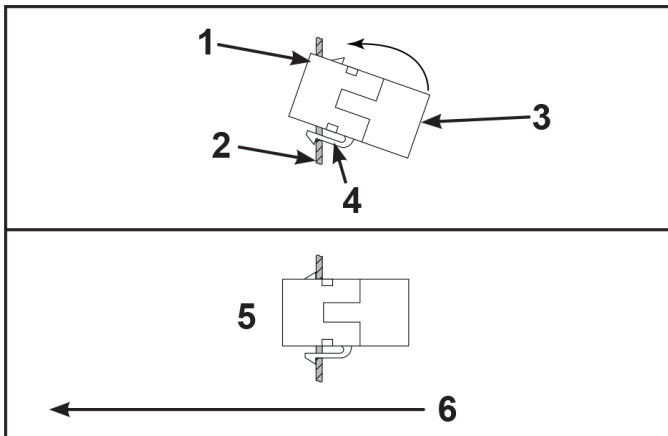

| | Description | Qty. |
|---|----------------|------|
| 1 | Upper tab | 1 |
| 2 | Mounting plate | 1 |
| 3 | CSAFE coupler | 1 |
| 4 | Lower tab | 1 |
| 5 | Installed | 1 |
| 6 | Front of unit | 1 |

- Unthread the nut at the end of the A/V cable.

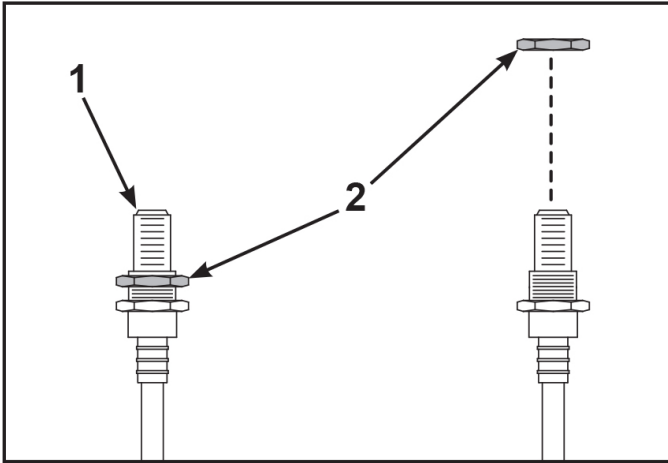

| | Description | Qty. |
|---|-------------|------|
| 1 | A/V cable | 1 |
| 2 | Nut | 1 |

- Insert the A/V cable into the D-shaped hole in the mounting plate on the front of the unit.

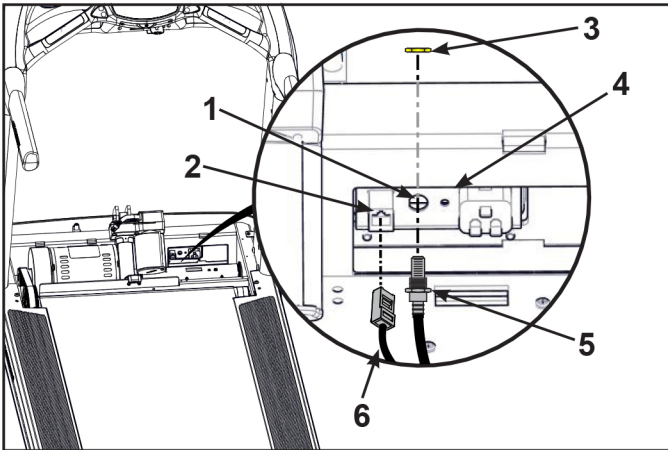

| | Description | Qty. |
|---|------------------|------|
| 1 | A/V cable hole | 1 |
| 2 | CSAFE coupler | 1 |
| 3 | Nut | 1 |
| 4 | Mounting plate | 1 |
| 5 | A/V cable | 1 |
| 6 | CSAFE cable, Red | 1 |

- Thread the nut removed in step 2 onto the A/V cable by hand.
- Install the A/V cable to the mounting plate on the front of the unit using a 14 mm open end wrench.
- Plug the CSAFE cable into the CSAFE coupler on the front of the unit.

Install shield

Tighten the seven screws securing the shield to the base using a Philips screwdriver.

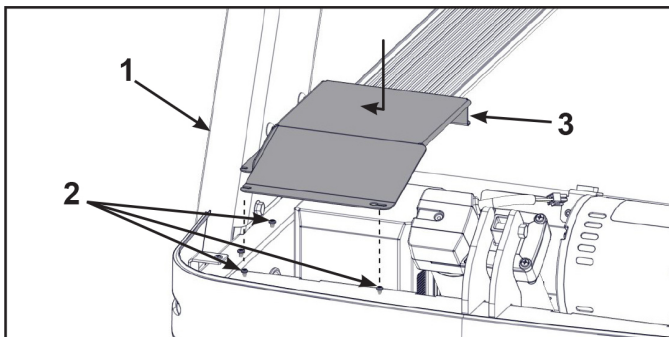

| | Description | Qty. |
|---|-------------|------|
| 1 | Base | 1 |
| 2 | Screws | 7 |
| 3 | Shield | 1 |

Install front cover

Perform this step if you removed the front cover. If not, skip to next step.

Install, but do not fully tighten the four screws securing the front cover to the base using a Philips screwdriver.

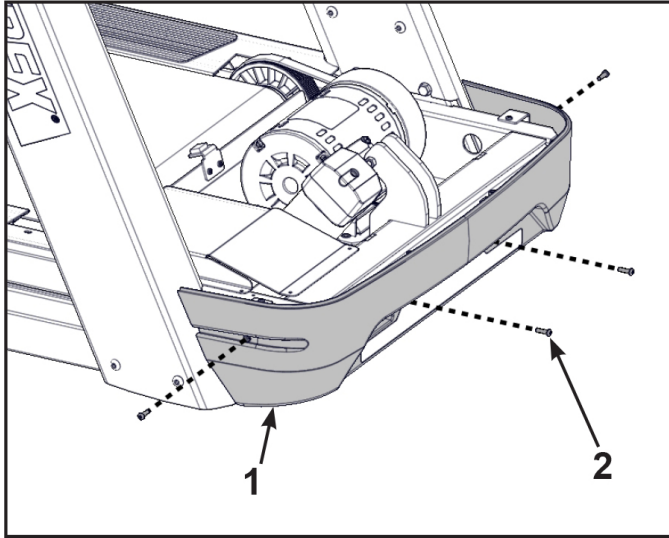

| | Description | Qty. |
|---|-------------|------|
| 1 | Front cover | 1 |
| 2 | Screws | 4 |

Install motor cover

1. Place motor cover on carpeting or other soft surface. Do not scratch top of hood cover.
2. Insert the four plastic connectors into the motor cover.

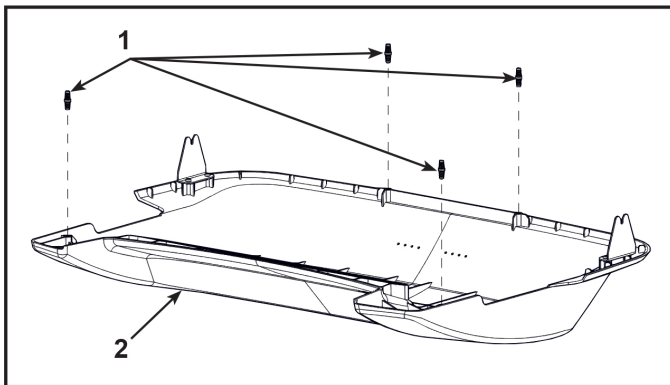

| | Description | Qty. |
|---|--------------------|------|
| 1 | Plastic connectors | 4 |
| 2 | Motor cover | 1 |

- Place the motor cover into position vertically by aligning the two tabs and four plastic connectors. Two plastic connectors are mounted in the front cover and two in the motor cover.

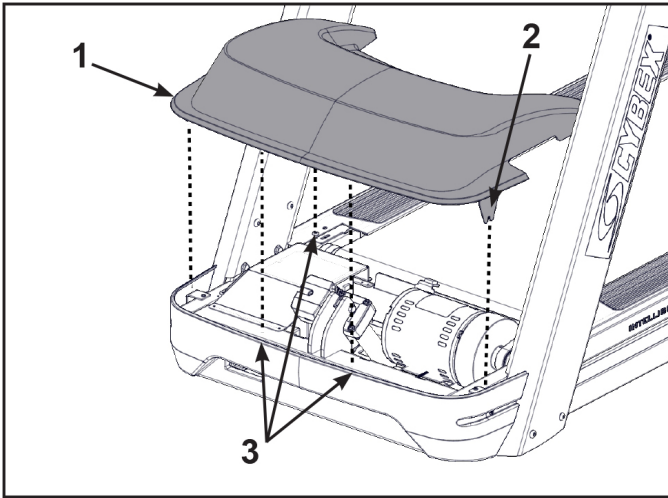

| | Description | Qty. |
|---|--------------------|------|
| 1 | Motor cover | 1 |
| 2 | Tabs | 2 |
| 3 | Plastic connectors | 1 |

If motor cover top does not fit properly, loosen the side screws on the front cover as needed.

- Using a Phillips screwdriver, finish tightening the four front cover screws. Be sure the screws are securing the motor cover's tabs.

Install power cord

⚠ WARNING

Shock and electrocution hazard.

- Route power cord so it does not become damaged.
- Do not allow cord to be pinched or interfere with movement of treadmill.

- Plug the power cord into the base of the unit.

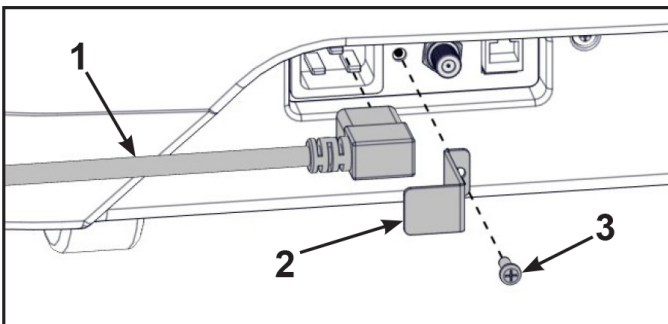

| | Description | Qty. |
|---|-------------|------|
| 1 | Power cord | 1 |
| 2 | Bracket | 1 |
| 3 | Screw | 1 |

- Secure the power cord with the mounting bracket and mounting screw using a Phillips screwdriver.

Level treadmill

Confirm that the treadmill is on a level surface.

Install coax cable (E3 View Monitor option)

Install 6' coax cable to the coax cable connector in base of unit. Do not install if facility provides coax cable to base of unit.

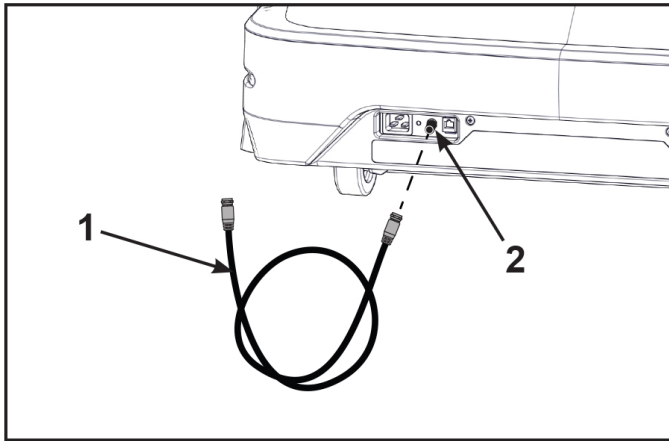

| | Description | Qty. |
|---|----------------------|------|
| 1 | 6' Coax Cable | 1 |
| 2 | Coax Cable Connector | 1 |

Install emergency stop key

Confirm that the emergency stop key is in place in the bottom of the console handrail. The treadmill will not run without the key in place.

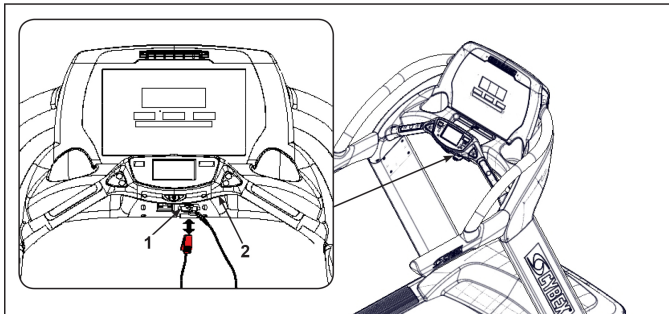

| | Description | Qty. |
|---|--------------------|------|
| 1 | Emergency Stop Key | 1 |
| 2 | Console Handrail | 1 |

When not in use store the e-stop clip on the storage tab located under the console handrail.

Visually inspect unit

1. Remove any packing material from unit.
2. Examine the unit to ensure that the assembly is correct and complete.

Power cord management

Power cord retaining brackets are located under the front end of the unit. This allows any extra length of the power cord to be stored under the front end of the unit.

Tools Required:

Wire tie (2)

WARNING

Shock and electrocution hazard.

- Route power cord so it does not become damaged.
- Do not allow cord to be pinched or interfere with movement of treadmill.

1. Connect the main power cord into the power outlet.
2. Press **Quick Start** and raise the elevation to maximum incline.
3. Toggle the on/off (I/O) power switch to the off (O) position. The on/off (I/O) power switch is located under the front end of the unit, or on the front right side panel.

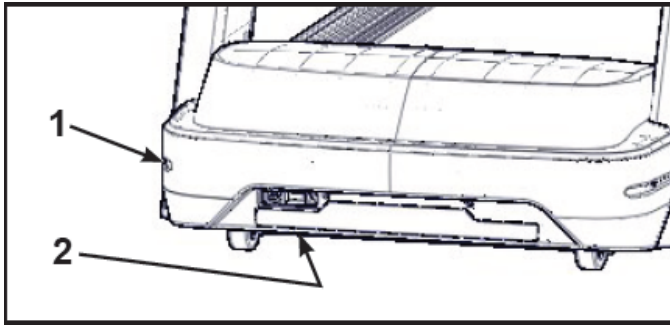

| | Description | Qty. |
|---|---------------------------------|------|
| 1 | Front right side panel location | 1 |
| 2 | Under the front end location | 1 |

4. Unplug the main power cord from the power outlet.
5. Wrap the power cord around the outer power cord retaining brackets to desired length.

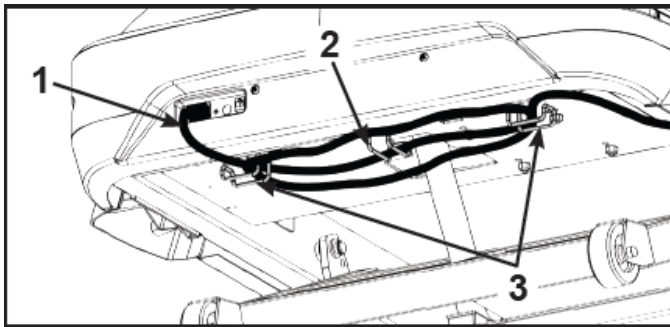

| | Description | Qty. |
|---|--------------------------------------|------|
| 1 | Power cord | 1 |
| 2 | Power cord retaining bracket, Inner | 1 |
| 3 | Power cord retaining brackets, Outer | 2 |

The power cord can be routed with full or half wraps around power cord retaining brackets. The power cord can then exit to the left or right of the treadmill.

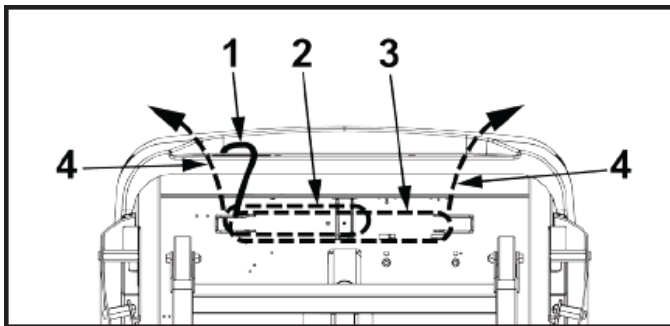

| | Description | Qty. |
|---|--------------------|------|
| 1 | Power cord | 1 |
| 2 | Half wrap | 1 |
| 3 | Full wrap | 1 |
| 4 | Exit left or right | 1 |

6. Plug the main power cord into the power outlet.
7. Toggle the on/off (I/O) power switch to the on (I) position.
8. Press **Quick Start** and operate the elevation through full incline. If power cord is too short or interferes with the movement of the treadmill, change the wrap of the power cord.

9. Secure the power cord with two wire ties.

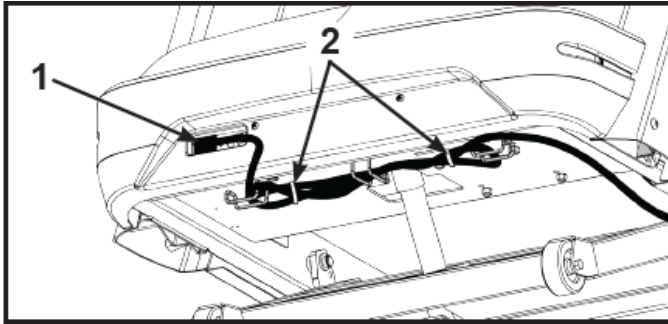

| | Description | Qty. |
|---|-------------|------|
| 1 | Power cord | 1 |
| 2 | Wire tie | 2 |

Setup

Use the following instructions to setup the unit.

⚠ WARNING

Falling hazard. When starting unit

- Stand on two top steps.
- Do not stand on belt.

Cybox recommends that the treadmill be unplugged or the on/off (I/O) power switch turned off (O) when it is not in use.

1. Without anyone on the treadmill, plug the power cord into a power outlet from a grounded, dedicated circuit.
Ensure the power cord is not being pinched under the front of the treadmill.
2. Toggle the on/off (I/O) power switch to the on (I) position. The on/off (I/O) power switch is located under the front end of the unit, or on the front right side panel.
3. The control panel will light up.

Initial setup

Initial setup only occurs during the installation of the unit. Once complete, refer to Setup Options below.

| | | |
|--|----------------------|--|
| | CYBEX LOGO | Press and hold Cybex logo for 6 seconds to access Screen Lock and Toolbox . |
| | LANGUAGE ICON | Press and hold language logo for 6 seconds to access Screen Lock and Toolbox . |

1. Tap the **Access Toolbox** icon to display the **Access to Toolbox** login screen.
2. Enter the sequence: .
3. Tap the **Setup** icon to display the **setup menu**.
4. Tap the **Time** icon to advance to the **Set the Time** screen.
5. Adjust the time if needed, then tap the **ENTER** icon .



6. Tap the **Date** icon to advance to the **Set the Date** screen.
7. Adjust the date if needed, then tap the **ENTER** icon .
8. Tap the **Units & Power** icon to select the **Set units preference** screen.
9. Select the unit preferences from the following options:
Record your actual line voltage here. Line frequency is usually specific to your country or location.





| Distance Units | Weight Units | Line Frequency | Line Voltage |
|----------------|--------------|----------------|--------------|
| Miles | Lbs. | 50 Hz | 110v |
| Km | Kg | 60 Hz | 115v |
| | Stone | | 208v |
| | | | 220v |
| | | | 230v |

10. Exit Set Up Mode by tapping the **Toolbox**  icon, then tap the **Home** icon . The screen will refresh.

Setup options

Enter setup options.

| | | |
|---|----------------------|--|
|  | CYBEX LOGO | Press and hold Cybex logo for 6 seconds to access Screen Lock and Toolbox . |
|  | LANGUAGE ICON | Press and hold language logo for 6 seconds to access Screen Lock and Toolbox . |

1. Tap the **Access Toolbox** icon to display the **Access to Toolbox** login screen.
2. Enter the sequence:     .
3. Tap the **Setup** icon to display the **setup menu**.

Setup menu

| | |
|------------------------|---|
| Time | Select Time Display option to On or Off. Add or subtract an hour. Select time display as AM, PM, or 24 Hour display. Enter time using keypad, press Enter icon to save. |
| Date | Select date style [MM] [DD] [YYYY], [DD] [MM] [YYYY], or [YYYY] [MM] [DD]. Y - Year, M - Month and D - Day. Enter date using keypad, press Enter icon to save. |
| Units and Power | Select distance units. Miles or Km (Kilometers). Select weight units. Lbs. (Pounds), Kg. (Kilograms) or Stone (Stones). Line frequency 50 or 60 Hz. Line voltage - displayed. |

| | |
|---|--|
| A/V Device (not shown for E3 View Monitor) | Select No TV or Wireless TV. |
| A/V Config (not shown for E3 View Monitor) | Active when A/V Device is set to Wireless TV. See A/V Config and FM Radio Presets . |
| FM Radio Presets (not shown for E3 View Monitor) | Active when A/V Device is set to Wireless TV. See A/V Config and FM Radio Presets . |
| PEM Setup | Active when A/V Device is set to Embedded TV. See E3 View Monitor Controls and E3 View Monitor Setup . |
| Workout times | Set Default and Max workout times. Default choices are 20, 30, or 60 minutes. Max choices are 20, 30, 60, or OFF. |
| Limits | Set Min Speed, Max Speed, and Max Incline. |
| Pause | Set Pause time. Choices are OFF, 1:00, 5:00, or 10:00 minutes. |
| Sound | Select console beeper settings. Console Beeper - On or Off. Headphone Beeper - Off, Some, or All. Default Volume - 1 to 30, default is 10. |
| Language | Select default language to display on CardioTouch screen. Toolbox is only available in English. Include Optional Languages. Select optional languages to display on CardioTouch screen. Choices are Include or Off . |
| Restore Factory Defaults | Restores all setup variables back to factory defaults. Does not affect Time or Date. |

Exit Set Up Mode

Exit Set Up Mode by tapping the **Toolbox**  icon, then tap the **Home** icon . The screen will refresh.

A/V Configuration and FM Radio Presets

Perform this procedure if the unit includes the optional Wireless Audio Receiver Module.

Tools Required:

Headphones (not included)

Setting up the Cybex Wireless Audio Receiver Module requires four steps:

1. Determine the type of transmitter used (MYE 900MHz, Broadcast Vision 863MHz, etc. or TV FM).
2. Set **A/V Device** to Wireless TV.
3. Assign a TV channel number to each transmitter on the console.
4. Add FM radio station presets (optional).

Determine transmitter type

There are two types of transmitters UHF or TV FM.

- UHF transmitters will have TV's identified by number, example TV1.
- TV FM transmitters will have TV's identified with FM frequencies, example 93.1.

UHF Transmitters

Follow procedure: Setup UHF Transmitters

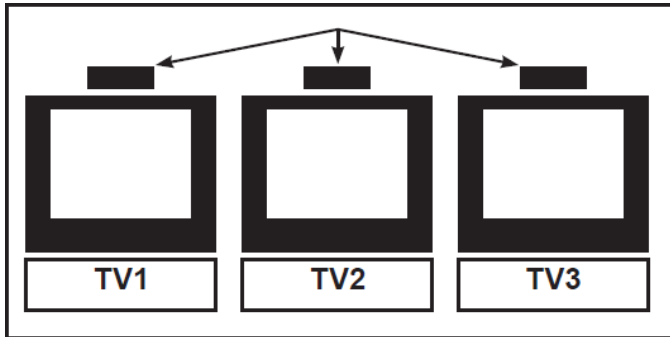

TV FM Transmitters

Follow procedure: Setup TV FM Transmitters

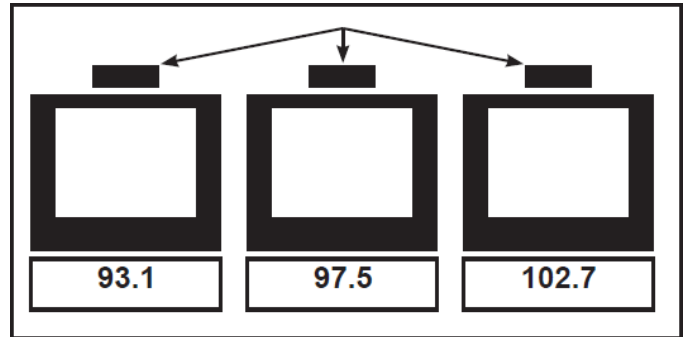

For TV FM transmitters, record FM frequencies for all TV's:

| 1 | 2 | 3 | 4 | 5 | 6 | 7 | 8 | 9 | 10 |
|---|---|---|---|---|---|---|---|---|----|
| | | | | | | | | | |



A/V setup mode

⚠ WARNING

Falling hazard. When starting unit



- Stand on two top steps.
- Do not stand on belt.

1. Plug the power cord into a power outlet from a grounded, dedicated circuit as described under Electrical Requirements in this chapter. Do not stand on treadmill during this procedure.
2. Ensure the power cord is not being pinched under the front of the treadmill.
3. Toggle the power switch on (I). Power switch is located under the front end of the treadmill. The control panel will light up and be in the Dormant Mode.

| | | |
|---|----------------------|--|
|  | CYBEX LOGO | Press and hold Cybex logo for 6 seconds to access Screen Lock and Toolbox . |
|  | LANGUAGE ICON | Press and hold language logo for 6 seconds to access Screen Lock and Toolbox . |

4. Tap the **Access Toolbox** icon to display the **Access to Toolbox** login screen.

5. Enter the sequence:     .

6. Tap **Setup** at the main **Toolbox** screen.
7. Tap the **Shift Right**  icon to navigate to the **A/V Device** icon.
8. Tap **A/V Device**.
9. Tap **Device Installed** to select **Wireless TV**.
10. Tap the **Toolbox**  icon to return to the **Toolbox** screen.
11. Plug in headphones to listen for channels during setup.

Setup UHF Transmitters

For transmitter types 900 MHz, 863 MHz or 806 MHz. Use this procedure to associate channel numbers to your TV transmitters. If using an FM transmitter system, skip to Setup TV FM Transmitters.

Pick transmitter type

For transmitter types 900 MHz, 863 MHz or 806 MHz. Use this procedure to associate channel numbers to your TV transmitters.

Pick transmitter type







1. Tap **Setup** at the main **Toolbox** screen.
2. Tap the **Shift Right**  icon to navigate to the **A/V Config** icon.
3. Tap **A/V Config** to enter **TV Configuration**.
4. Tap **Select Xmtr** to select your transmitter type from the available choices. The display will only show choices available under your transmitter type (900 MHz, 863 MHz or 806 MHz).

| 900 MHz System | 863 MHz System | 806 MHz System |
|--------------------------|------------------|----------------------------|
| "M 900" MYE | "M 863" MYE | "J1 806" Japan 14 channels |
| "C 900" Cardio Theater | "E 863" Exercise | "J2 806" Japan 30 channels |
| "E 900" Exercise | "A 863" Audeon | |
| "B 900" Broadcast Vision | | |

5. Tap **Scan** to scan for available channels. The scan can take up to 10 seconds and then display TV-1 of #. The "#" symbol is total number of strong UHF channels found. Some of these channels may not be signals from the TV transmitters and need to be deleted.



Review channels

1. Tap **Up**  or **Down**  to listen to available channels with the headphones.
2. Delete unwanted channels by pressing **Delete** to delete channel. Repeat process for additional unwanted channels.
3. Adjust the Near/Far setting for channels that are available but not showing.
 - a) Press **Far** to change the setting from FAR to NEAR.
 - b) Press **Scan** to re-scan for available channels.
4. Tap **Up**  or **Down**  to scroll through and verify all TV channels. If all TV transmitters are stored, and they all correlate the TV number to the correct TV heard, setup is complete. If not you may need to re-scan or adjust the transmitter codes (see documentation for your transmitters to perform a code change.)
5. Exit Set Up Mode by tapping the **Toolbox**  icon, then tap the **Home** icon . The screen will refresh.
Transmitter setup complete.



Proceed to **Add FM radio stations (optional)**.

Setup TV FM Transmitters



If your TV's use FM transmitters, follow these instructions to assign a TV channel to each frequency.

1. Tap **Setup** at the main **Toolbox** screen.
2. Tap the **Shift Right**  icon to navigate to the **A/V Config** icon.
3. Tap **A/V Config** to enter **TV Configuration**.
4. Tap **Select Xmtr** to select your transmitter type as TV FM.

Enter TV channels

1. Enter TV channels using one of the following procedures
 - Tap **Seek** to seek the next TV FM frequency or **Up**  or **Down**  to tune manually. Press **Add** to store channel.
 - Tap the keypad numbers to enter known channel, Press **Enter** and **Add** to store channel.











2. Repeat procedure to add all TV FM channels.
3. Exit Set Up Mode by tapping the **Toolbox**  icon, then tap the **Home** icon . The screen will refresh.

Transmitter setup complete. Proceed to *Add FM Radio Stations (optional)*.



Add FM Radio Stations (optional)

If strong local FM Radio Stations are available in the area, you can set those as presets.





| | | |
|--|----------------------|--|
|  | CYBEX LOGO | Press and hold Cybex logo for 6 seconds to access Screen Lock and Toolbox . |
|  | LANGUAGE ICON | Press and hold language logo for 6 seconds to access Screen Lock and Toolbox . |

1. Tap the **Access Toolbox** icon to display the **Access to Toolbox** login screen.
2. Enter the sequence:     .
3. Tap **Setup** at the main **Toolbox** screen.
4. Tap the **Shift Right**  icon to navigate to the **FM Radio Presets** icon.
5. Tap **FM Radio Presets** to display **FM Radio Presets** on the console.





Enter FM radio channels

1. Enter FM radio channels using one of the following procedures
 - Tap **Seek** to seek the next FM radio frequency or **Up**  or **Down**  to tune manually. Tap **Add** to store channel.
 - Tap the keypad numbers to enter known channel. Press **Enter** and **Add** to store channel.



2. Repeat procedure to save up to 32 FM radio stations.
3. Tap **Up**  or **Down**  to scroll through and verify all FM radio stations.
4. Exit Set Up Mode by tapping the **Toolbox**  icon, then tap the **Home** icon . The screen will refresh.

Using the Cybox Wireless Audio Receiver













1. Plug headphones into headphone jack.
2. Tap the TV icon to listen to TV channels. Press the FM icon to listen to FM radio channels.
3. Tap **Up**  or **Down**  to change TV or FM channels.
4. Tap volume **Up**  or **Down**  to adjust volume.

E3 View Monitor Controls

The CardioTouch screen is used to perform all setup operations for the E3 View Monitor.











CardioTouch screen functions

| | | |
|---|-----------------------------|---|
|  | Wrench Icon | Return to Toolbox home |
|  | Up | Go to Setup home screen |
|  | Next | Moves forward in Setup menu to next screen |
|  | Default Display Mode | Select TV + Data, TV Only or Data Only |
|  | On/Off | Turn the E3 View Monitor on or off |
|  | Reset Defaults | Reset the setup values and clear all programmed channels. |
|  | CH List | List all available channels |
|  | Setup | Toggles the setup menu |
|  | Navigate up | Navigate up through the on-screen menu |
|  | Navigate down | Navigate down through the on-screen menu |
|  | Navigate left | Decrease value |
|  | Navigate right | Increase value |

E3 View Monitor Setup

Access Setup Screen

| | | |
|---|----------------------|--|
|  | CYBEX LOGO | Press and hold Cybex logo for 6 seconds to access Screen Lock and Toolbox . |
|  | LANGUAGE ICON | Press and hold language logo for 6 seconds to access Screen Lock and Toolbox . |

1. Tap the **Access Toolbox** icon to display the **Access to Toolbox** login screen.
2. Enter the sequence:     .
3. Tap the **Setup** icon to display the **setup menu**.
4. Tap the **Shift Right**  icon to navigate to the **EPEM Setup** icon.
5. Tap the **EPEM Setup** icon.
6. Tap the **Setup**  icon to advance to the **SETUP MODE** screen. Follow procedure to setup the E3 View Monitor.

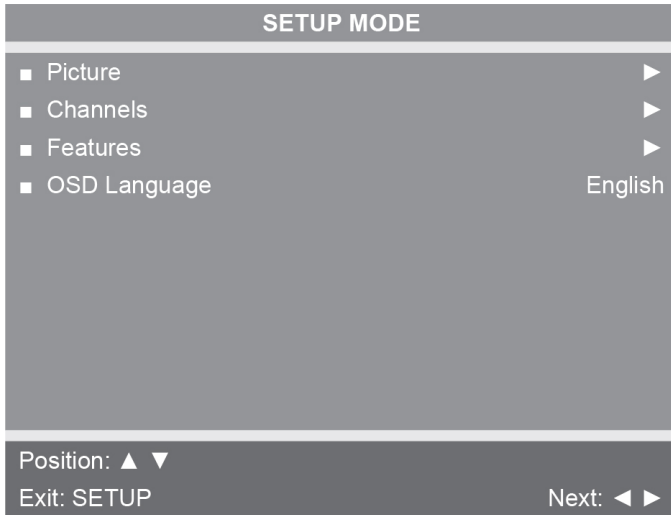

| |
|---------------------|
| Picture |
| Channels |
| Features |
| OSD Language |

Picture

1. Tap ▲ or ▼ to select **Picture**.

2. Tap ► to access access **Picture** menu.

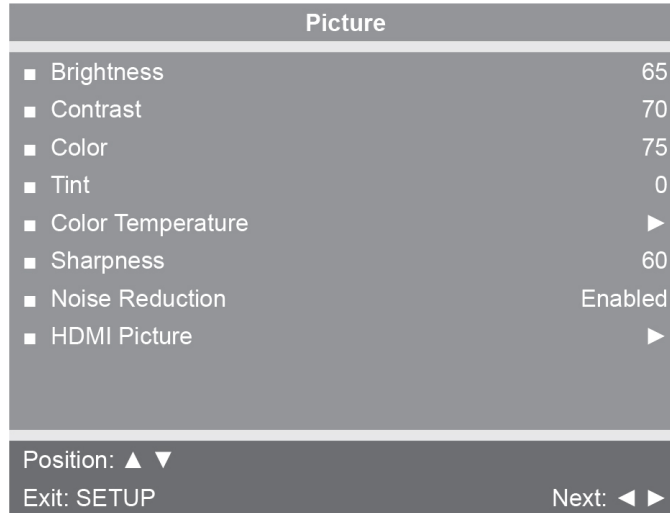

| | |
|--------------------------|---|
| Brightness | Adjust range from 1 to 100. Default is 65. |
| Contrast | Adjust range from 1 to 100. Default is 70. |
| Color | Adjust range from 1 to 100. Default is 75. |
| Tint | Adjust range from 1 to 100. Range is R50 to G50. Default is 0. |
| Color Temperature | Adjust color balance of Red, Green and Blue temperatures. |
| Sharpness | Adjust range from 1 to 100. Default is 60. |
| Noise Reduction | Select Enabled (Default) or Disabled. |
| HDMI Picture | Set to Auto or Adjust settings as needed. Available only when HDMI signal is present. |

3. Tap ▲ or ▼ to select settings.
4. Tap ◀ or ▶ to adjust settings.
5. Tap the **Setup**  icon to advance to the **SETUP MODE** screen.

Channels

1. Tap ▲ or ▼ to select **Channels**.

2. Tap ► to access **Channels** menu.

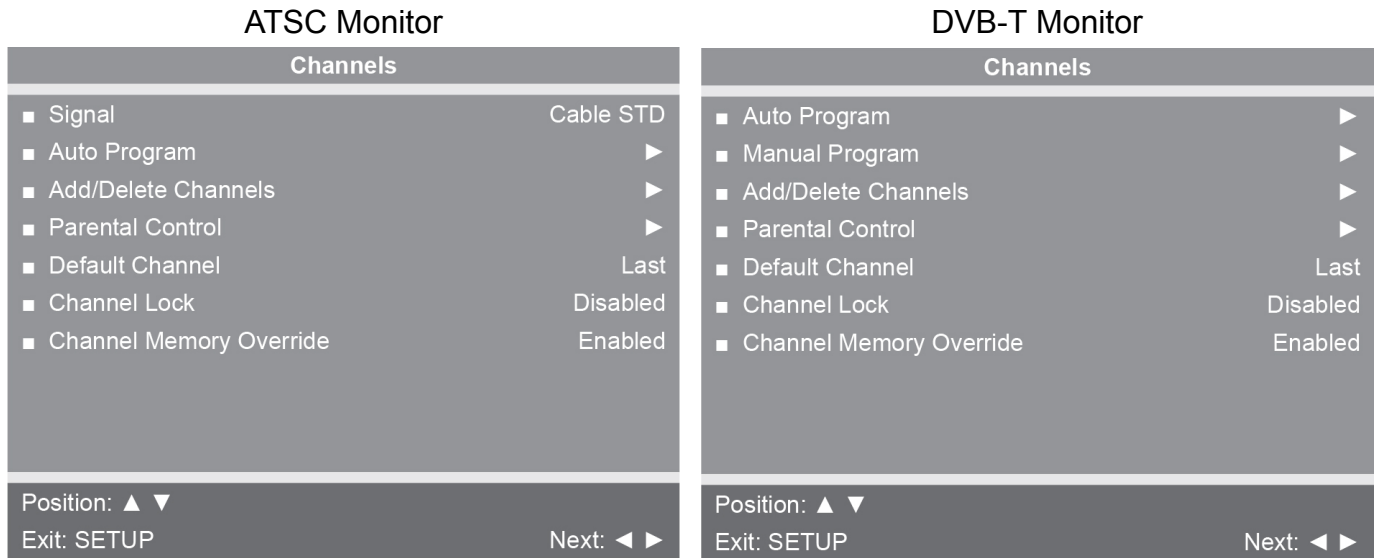

| Feature | Settings |
|------------------------------------|---|
| Signal (ATSC only) | Select Air, Cable STD, Cable IRC, or Cable HRC. |
| Auto Program | <i>See Below</i> |
| Manual Program (DVB-T only) | <i>See Below</i> |
| Add/Delete Channels | <i>See Below</i> |
| Parental Control | Block channels based on TV ratings. |
| Default Channel | Select channel to display on power up. Select from available channels or last. |
| Channel Lock | Select Enabled or Disabled . If enabled only one channel is shown, user cannot change channels. |
| Channel Memory Override | Select Enabled or Disabled . If enabled allows user to select any available channel. |

3. Tap ▲ or ▼ to select settings.

4. Tap ◀ or ▶ to adjust settings.

Auto Program (ATSC Monitor)

1. Tap ▼ to select **Auto Program**.

2. Tap ► to enter the menu.

3. Tap ▲ or ▼ to select **Mode**.

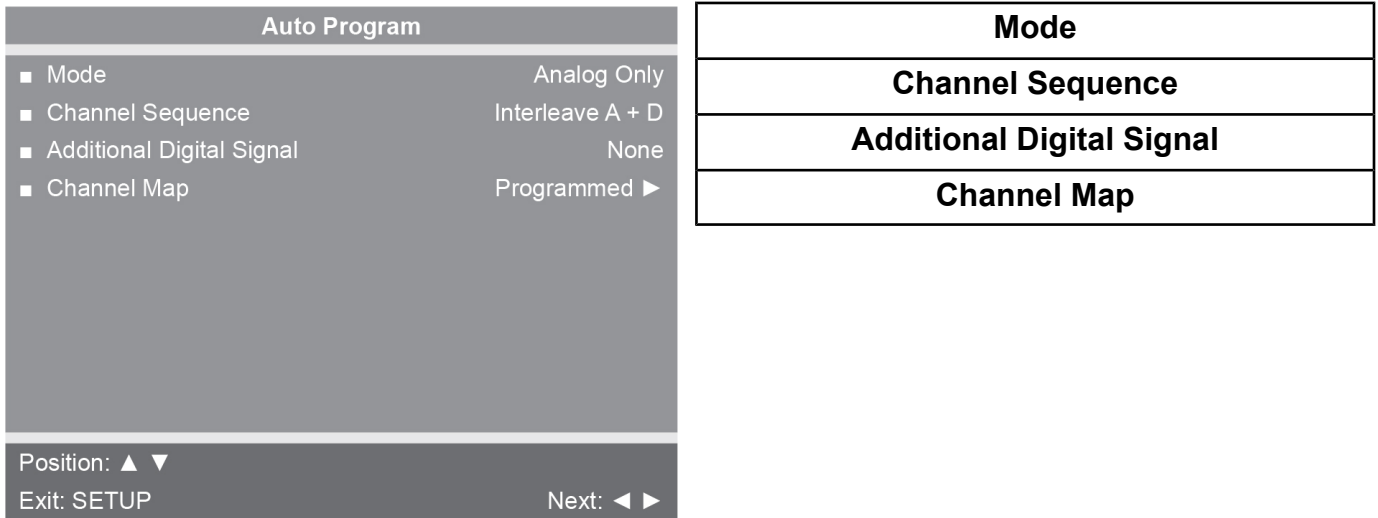

Figure 1: ATSC Monitor

4. Tap ◀ or ▶ to set the scope of channel scanning.

| Option | Description |
|------------------------------|--|
| Analog Only (Default) | TV searches for analog channels only |
| Digital Only | TV searches for digital channels only |
| Analog and Digital | TV searches for both analog and digital channels |

5. Tap ▼ to select **Channel Sequence**.

6. Tap ◀ or ▶ to set the Channel Sequence in which the channels are displayed after searching.

| Option | Description |
|-----------------------|---|
| Interleave A+D | In the order of channel number regardless of the system. |
| All A then D | Digital channels are displayed after all analog channels. |

7. Tap ▲ or ▼ to select **Additional Digital Signal**. Not available when **Mode** is set to Analog Only.

8. Tap ◀ or ▶ to choose the **Additional Digital Signal** source.



- None
- Air
- Cable STD
- Cable IRC
- Cable HRC

9. Tap ▼ to select **Channel Map**.

10. Tap ▶ to start auto programming. A confirmation menu will appear before proceeding.

11. Tap ▲(Yes) to start auto programming. Tap ▼(No) button to cancel the operation. The TV will now search all available channels with an on-screen progress percentage displayed. Any tuning Mode that includes Digital channels will require several minutes to complete auto programming.

This may take 20 or more minutes. If screen shuts off, tap the  icon to turn monitor on.

12. Tap the **Setup**  icon to return to normal TV viewing once auto programming is complete.
13. Tap the **CH List**  icon to list programmed channels.
14. Tap the **Setup**  icon to return to **SETUP MODE** menu.

Auto Program (DVB-T Monitor)

1. Tap ▼ to select **Auto Program**.
2. Tap ► to enter the menu.
3. Tap ▲ or ▼ to select **Country**.

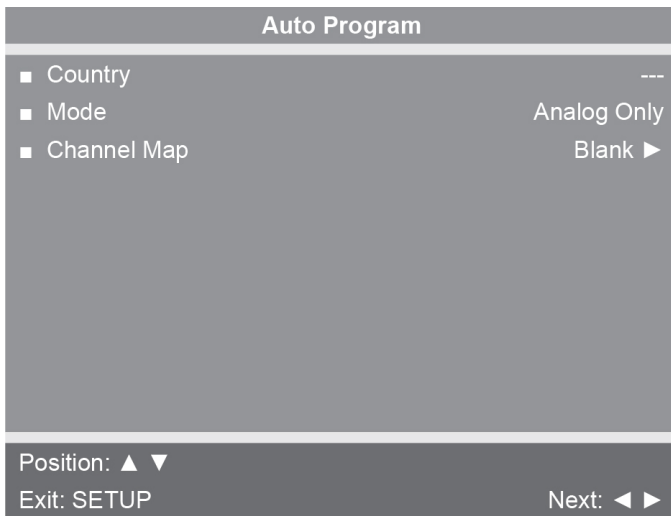

| |
|--------------------|
| Country |
| Mode |
| Channel Map |

Figure 2: DVB-T Monitor

Available countries are:

Albania, Austria, Australia, Belgium, Bosnia, Bulgaria, China, Croatia, Czech, Denmark, Estonia, Finland, France, Germany, Greece, Hungary, Ireland, Italy, Kazakhstan, Latvia, Lithuania, Luxembourg, Morocco, Netherlands, Norway, Poland, Portugal, Romania, Russia, Serbia, Slovakia, Slovenia, Spain, Sweden, Switzerland, Turkey, UK, and Ukraine.

4. Tap ▲ or ▼ to select **Mode**.

5. Tap ◀ or ▶ to set the scope of channel scanning.

| Option | Description |
|------------------------------|--|
| Analog Only (Default) | TV searches for analog channels only |
| Digital Only | TV searches for digital channels only |
| Analog and Digital | TV searches for both analog and digital channels |

6. Tap ▼ to select **Channel Map**.

7. Tap ▶ to start auto programming. A confirmation menu will appear before proceeding.

8. Tap ▲(Yes) to start auto programming. Tap ▼(No) button to cancel the operation. The TV will now search all available channels with an on-screen progress percentage displayed. Any tuning Mode that includes Digital channels will require several minutes to complete auto programming.

This may take 20 or more minutes. If screen shuts off, tap the  icon to turn monitor on.

9. Tap the **Setup**  icon to return to normal TV viewing once auto programming is complete.

10. Tap the **CH List**  icon to list programmed channels.

11. Tap the **Setup**  icon to return to **SETUP MODE** menu.

Manual Program (ATSC and DVB-T)

1. Tap ▼ to select **Manual Program**.

2. Tap ▶ to enter the menu.

3. Tap ▲ or ▼ to select **Mode**.

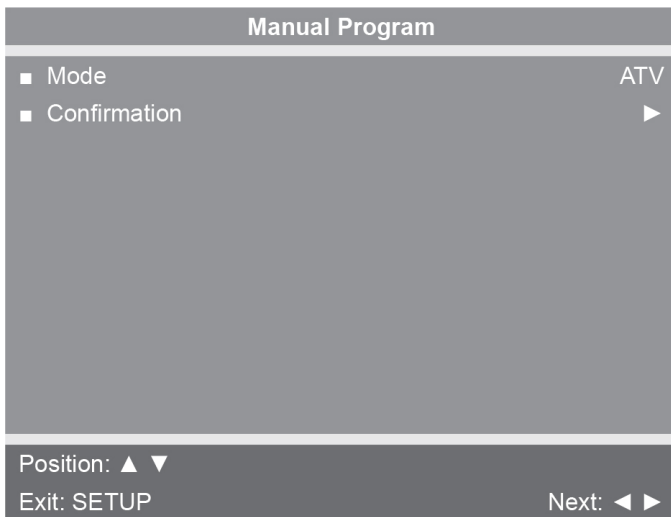

| |
|---------------------|
| Mode |
| Confirmation |

4. Tap ◀ or ▶ to select **ATV** or **DTV**.

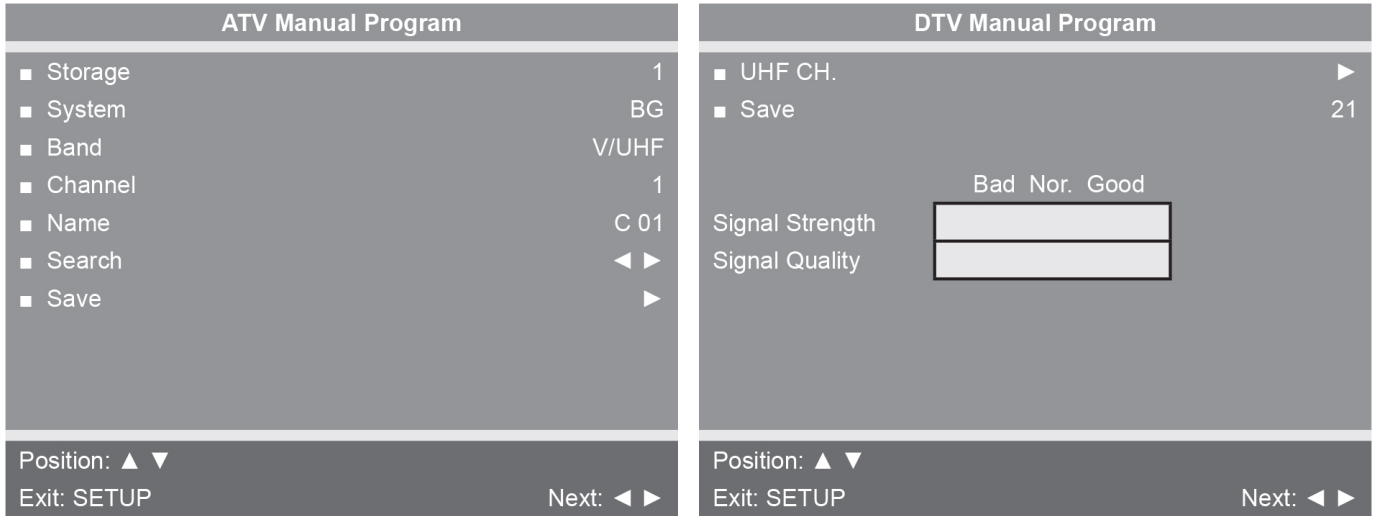

| | |
|-----------------|---|
| ATV Mode | Adjust settings for Storage , System , Band , Channel , Name , or Search . Select Save to save settings. |
| DTV Mode | Select UHF channel . Select Save to save settings. |

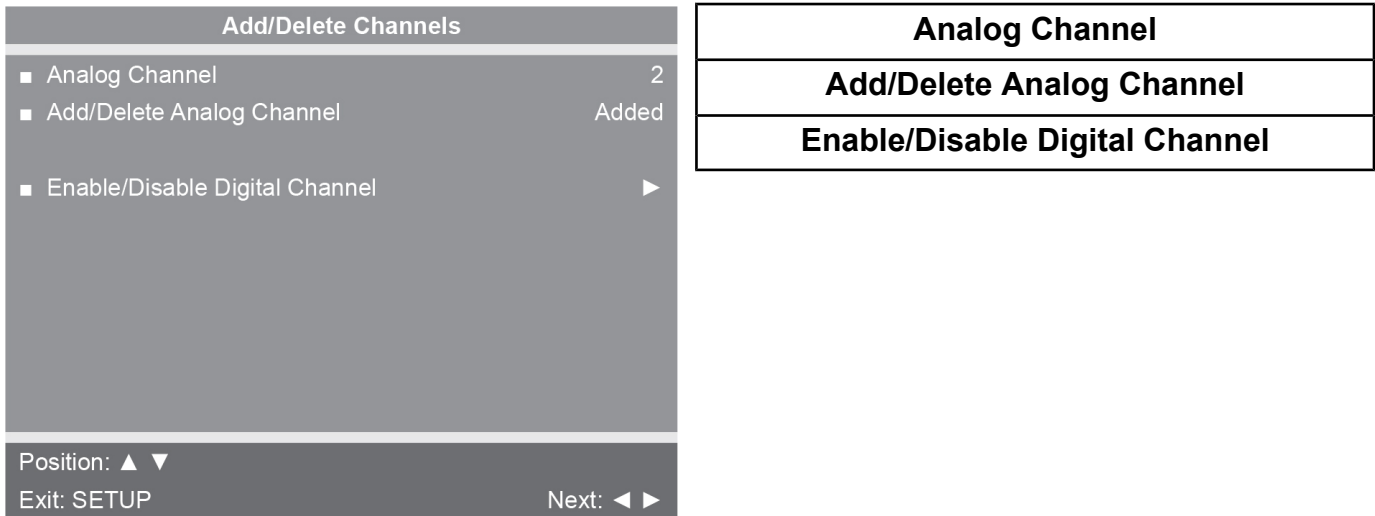

Add/Delete Channels (ATSC and DVB-T)

1. Tap ▼ to select **Add/Delete Channels**.
2. Tap ▶ to enter the **Add/Delete Channels** menu.



To add or delete an analog channel perform the following procedure. To enable or disable digital channels, go to step 7.

3. Tap ◀ or ▶ to select the desired analog channel.
4. Tap ▲ or ▼ to highlight **Add/Delete Analog Channel**.
5. Tap ◀ or ▶ to select **Added** or **Deleted**.

6. Tap the **Setup**  icon to return to the previous menu.
 To exit, Tap the **Setup**  icon until the programming menus disappear. If there are more analog channels to be added or deleted, repeat steps 3 through 5.
7. Tap ▲ or ▼ to highlight **Enable/Disable Digital Channel**.
8. Tap ► to access **Enable/Disable Digital Channel**. If there are not any channels programmed in the Service Level, No Channels Present will appear in the menu.
9. Tap ▲ or ▼ to highlight the digital channel that needs to be enabled or disabled.
10. Tap ◀ or ▶ to select **Enable** or **Disable**.
11. Tap the **Setup**  icon to return to the previous menu.

Features

1. Tap ▲ or ▼ to select **Features**.
2. Tap ► to access **Features** menu.

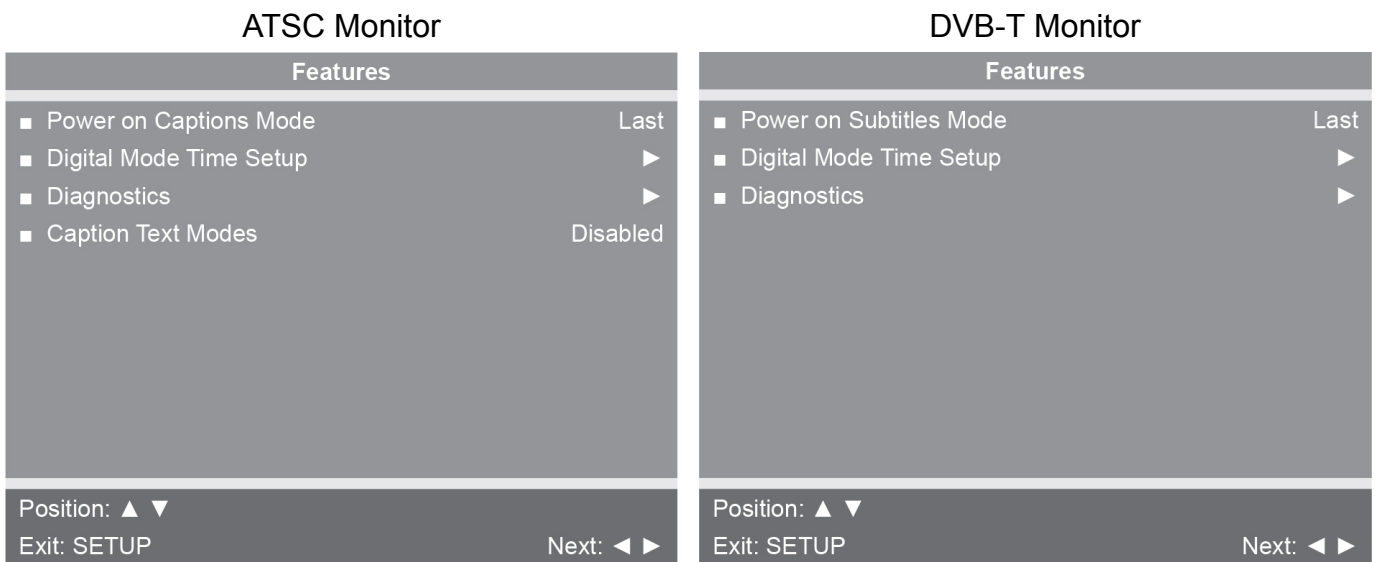

3. Tap ▲ or ▼ to select settings.

4. Tap ◀ or ▶ to adjust settings.

| Feature | Settings |
|--|---|
| Power on Captions Mode (ATSC only) | Select Off or Last. Last will set caption mode to last used setting. |
| Power on Subtitles Mode (DVB-T only) | Select Off or Last. Last will set subtitle mode to last used setting. |
| Digital Mode Time Setup | Set current time automatically from digital signal. Select time zone and daylight savings time to Auto, On, or Off. |
| Diagnostics | Provides diagnostic information only. Settings cannot be changed. |
| Caption Text Modes (ATSC only) | Select Enabled or Disabled. |

5. Tap the **Setup**  icon to return to **SETUP MODE** menu.

OSD Language

1. Tap ▲ or ▼ to select **OSD Language**.

2. Tap ◀ or ▶ to select language.

| Option | Description |
|----------------------|--|
| ATSC choices | English, Français or Español. |
| DVB-T choices | English, Français, Español, Dutch, Danish, Russian, German, and Swedish. |

3. Tap the **Setup**  icon to return to **SETUP MODE** menu.

4. Exit Set Up Mode by tapping the **Toolbox**  icon, then tap the **Home** icon . The screen will refresh.

Setup Complete

Testing Operation

Use the following instructions to test the full speed and incline range of the treadmill and to check the belt for proper operation.

⚠ WARNING

Falling hazard. When starting unit

- Stand on two top steps.
- Do not stand on belt.

1. Plug the power cord into a power outlet from a grounded, dedicated circuit without anyone on the treadmill.
Ensure the power cord is not being pinched under the front of the treadmill.
2. Toggle the on/off (I/O) power switch to the on position (I). The on/off (I/O) power switch is located under the front end of the unit, or on the front right side panel.
3. Press the **Quick Start** key.
The treadmill begins a countdown 3...2...1 and sounds a tone for each count. After it reaches one (1), the treadmill gives a longer tone and then begins accelerating the belt to reach 0.5 mph (0.8 kph). The lower left display will show the incline and the lower right display will show the actual speed.
4. Press and hold down the **Speed +** key until the treadmill reaches a speed of approximately 4 mph (6.4 kph), as indicated on the display.
5. Observe the belt to see that it is running properly; it should stay centered in the middle of the deck. If you have problems with the running belt operation, see Running Belt Adjustments in the Maintenance chapter.
6. Run the treadmill through its full speed range.
 - a) First press the **Speed -+** key until the treadmill reaches its highest speed.
 - b) Then press the **Speed - -** key until the treadmill is back to 0.5 mph (0.8 kph).
Pressing the Incline **▲ ▼** or **Speed -+ -** keys will show the set incline or speed on the displays. When the treadmill reaches the set incline and speed, the displays will remain steadily illuminated to indicate that the desired settings have been reached.
7. Run the treadmill through its full % grade range.
 - a) Press the **Incline ▲** key until the treadmill reaches its highest grade.
 - b) Then press the **Incline ▼** key until the treadmill reaches 0% grade.
8. Press the **STOP** key once to stop the running belt and enter **Review Mode**.
9. Press the **STOP** key again to exit **Review Mode** and return the display to the opening screen.

Operation

Intended Use

The intended commercial use of this machine is to aid exercise and improve general physical fitness.

Terms Used

This section lists some of the common terms and symbols used in this chapter. Other terms and symbols are listed in this chapter as appropriate.

| | |
|---------------------------|---|
| Active Mode | Active Mode is when the running belt is moving. Before Active Mode begins, a three second countdown and 3...2...1 is displayed. Active Mode continues until the preset time limit is reached, the e-stop key is pulled out or the STOP key is pressed. |
| CardioTouch Screen | The CardioTouch Screen is the touch screen located in the handset area. |
| Cool Down | A reduction of work load for a short duration allows user to gently reduce heart rate. Cool Down occurs two minutes prior to completion of the workout-controlled workout sessions. |
| Dormant Mode | Occurs when unit is plugged in and not in use. |
| Manual Mode | In this active mode the user sets a goal for Time. The user controls speed and incline. Manual Mode continues until the goal is reached. Manual Mode is only available during Active Mode. |
| Pause Mode | Occurs only if the Pause feature is enabled and user selects the STOP key from Active Mode. |
| Quick Start | This begins by tapping the Quick Start icon. User has full control over the workout as time counts up. |
| Workout Review | Review of the accumulated workout data will happen at the end of each workout session. |

Console Display

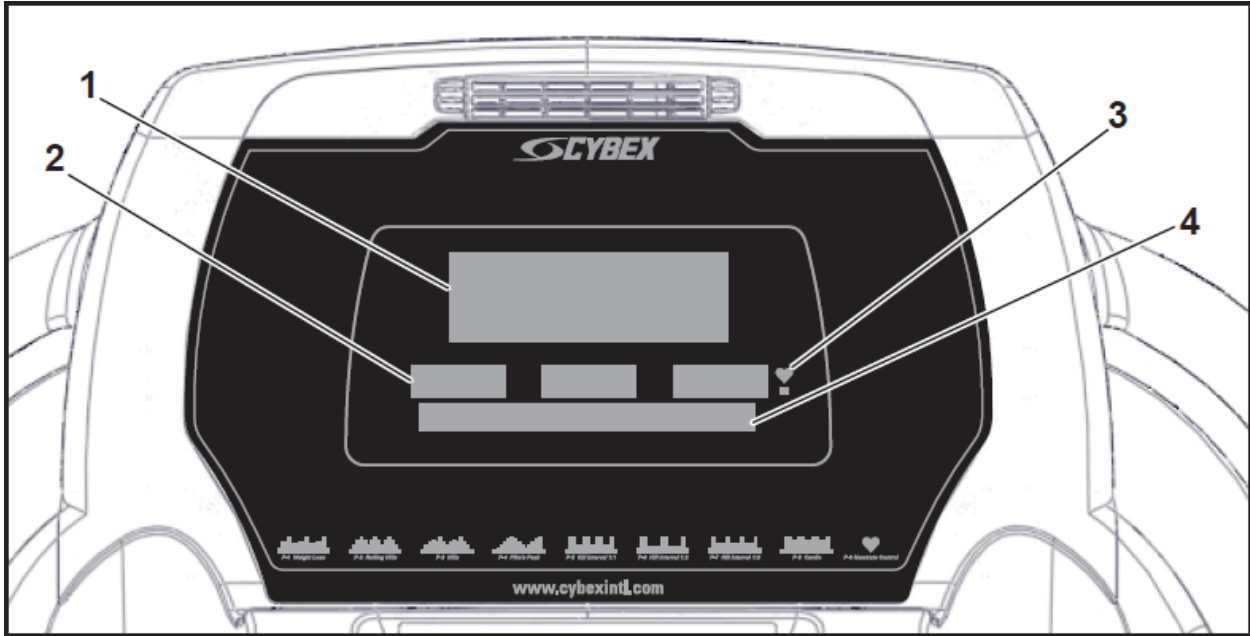

Figure 3: LED Display











| | | | |
|---|---------------|---|----------------------|
| 1 | Bar Graph | 3 | Heart Rate Indicator |
| 2 | Data Readouts | 4 | Enunciator |



Figure 4: E3 View Monitor

User Control Symbols Used











| Control | Control Name | Description |
|---|------------------------------|--|
|  | INCLINE UP | Adjust Incline up. |
|  | INCLINE DOWN | Adjust Incline down. |
|  | SPEED UP | Adjust Speed up. |
|  | SPEED DOWN | Adjust Speed down. |
|  | VOLUME UP | Adjust Volume up. |
|  | VOLUME DOWN | Adjust Volume down. |
|  | CHANNEL/TRACK CONTROL | iPod - NEXT track A/V - Channel UP |
|  | CHANNEL/TRACK CONTROL | iPod - PREVIOUS track A/V - Channel DOWN |
|  | STOP | Press STOP once to end the workout session and start the <i>Workout Review</i> . Press STOP again to exit to <i>Dormant Mode</i> . |
|  | FAN | Default speed is OFF during active mode. Press the FAN key to control fan speed. Choices are OFF, LOW and HI. |

CardioTouch Symbols Used

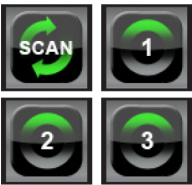

| Icon | Icon Name | Description |
|------|--------------------|--|
| | Quick Start | Quick Start enters Active Mode at the default settings with time counting up from 0:00. |
| | WORKOUTS | Tap Workouts icon to enter workout group selection. |
| | TV | Tap TV icon to enter TV control menu. If TV is not connected, icon will not be shown. |
| | TV + FM | Tap TV + FM icon to enter TV + FM control menu. If TV + FM is not connected, icon will not be shown. |
| | iPod | Tap iPod icon to enter iPod/iPhone control menu. If iPod/iPhone is not connected, icon will be grayed out. |
| | HOME | Return to opening screen. |
| | START | Enter Active Mode . |
| | PAUSE | If pause feature is enabled, pause icon is shown. Press Pause icon once to enter pause mode. |
| | STOP | If pause feature is disabled, stop icon is shown. Press Stop icon or STOP button once to enter Workout review . |
| | BACK | Return to previous or opening screen. |
| | UP LEVEL | Go up one level. |

| Icon | Icon Name | Description |
|---|---------------|---|
|  | SHIFT LEFT | Shift the screen left to view more options. |
|  | SHIFT RIGHT | Shift the screen right to view more options. |
|  | KEYPAD | Numeric keypad for entering data. |
|  | ENTER | Accepts the value shown. |
|  | CLEAR | Clear any values selected. |
|  | INFO | Select to provide more information and details. |
|  | SCALE | Displays current value in the minimum and maximum range. |
|  | SCAN | This icon defaults to SCAN, which displays the workout info on the upper display, changing every 5 seconds. Tap the SCAN icon to display different data sets. Tap again to change the data set, or multiple times to get back to SCAN. |
|  | CYBEX LOGO | Press and hold Cybex logo for 6 seconds to access Screen Lock and Toolbox . |
|  | LANGUAGE ICON | Press and hold language logo for 6 seconds to access Screen Lock and Toolbox . |

CardioTouch Screen and User Controls



| | | | |
|---|---------------------------|---|--------------------|
| 1 | Incline keys | 6 | Volume Keys |
| 2 | Incline display | 7 | STOP Key |
| 3 | CardioTouch screen | 8 | Fan Key |
| 4 | Speed display | 9 | Channel/Track Keys |
| 5 | Speed Keys | | |



Figure 5: CardioTouch Screen — Tap the icons to make selections.

Changing Speed

Press the **Speed+** - keys to change the speed in increments of 0.1 mph or 0.1 kph. Minimum to maximum speed is from 0.5 - 12.4 mph (0.8 - 20 kph).

Changing Incline

Press the **Incline** keys to change the elevation in increments of ½% increments up to 10%, then 1% up to 15%. Press multiple times to change incline setting or hold the key to auto-repeat. Elevation is defined as the ratio of rise or fall over run of the treadmill deck.

Changing between active mode or workouts

You can make changes during your workout. Press **WORKOUTS** to select another workout, **Manual** to select Manual Mode, or **Goal** to change your Time, Distance, or Calorie Goal. Follow screen prompts to begin the new workout.

Quick Operation Guide

The following is a quick overview of the operation. For more information see *Detailed Operation Guide*. Maximum user weight is 400 lbs. (181 kg).

WARNING

Falling hazard. When starting unit

- Stand on two top steps.
- Do not stand on belt.

1. Place your feet on the two top steps located on each side of the running belt.
2. Clip the e-stop clip onto your clothing and test it as described under *Emergency Stop* in the *Safety* chapter.
3. Tap **Quick Start** on the **CardioTouch** screen.



The treadmill begins a countdown, 3...2...1, after which it accelerates the belt to 0.5 mph (0.8 kph) and enters Active Mode.



4. Hold the handrails while you step onto the running belt and begin walking.
5. Press the **Speed+** - keys to change the belt speed at any time. The right display will show speed.
6. Press the **Incline** ▲ ▼ keys to change the incline at any time. The left display will show incline.
7. Press the **STOP** key at any time to stop the running belt. **Workout Review** is displayed and the incline returns to 0%.

Detailed Operation Guide

Maximum user weight is 400 lbs. (181 kg).

⚠️ WARNING

Falling hazard. When starting unit

- Stand on two top steps.
- Do not stand on belt.

1. Place your feet on the two top steps located on each side of the running belt.
2. Clip the e-stop clip onto your clothing and test it as described under *Emergency Stop* in the *Safety* chapter.

See Emergency Stop Key (e-stop) in the Safety Chapter for properly testing the e-stop key. Also, see Stopping the Treadmill in this chapter for further information about the e-stop key. Be sure the string is free of knots and has enough slack for you to run comfortably with the e-stop key in place.

3. Select **QUICK START** or **WORKOUTS**.

To select a workout category, tap one of the workout category icons from the workout options screen.

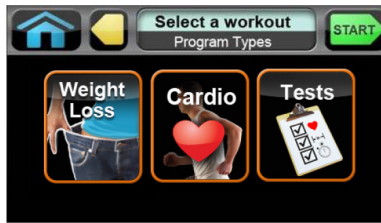

To select a workout, tap one of the workout icons from the workouts screen.

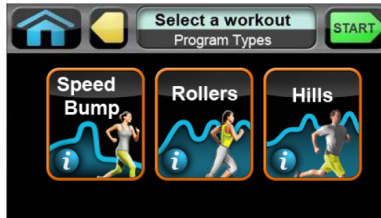

Upon entering a workout the display will guide you through the appropriate settings. This is referred to as Workout Setup Mode. If the **Start** key is pressed now, all defaults for that workout will be accepted. After 10 seconds, if no key has been pressed, the first default will be accepted. After another 10 seconds the second default will be accepted and so on until the last default.

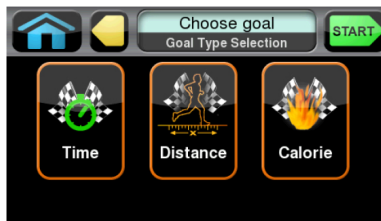

For the most accurate resistance and calorie count, you must set your correct weight before beginning your workout (including clothing).

When selecting a workout you must tap the **Enter** icon after each adjustment of *Time*, *Level* or *Weight*.

4. Press the **Start** key.

The treadmill begins a countdown, 3...2...1 and sounds a tone for each count. When it reaches one (1) the treadmill gives a longer tone and then starts accelerating the belt. In *Manual Mode* the belt will begin accelerating to 0.5 mph (0.8 kph) and the incline will remain at zero percent. In a workout the belt will begin accelerating and the incline will change to the corresponding speed and incline of the workout and level you selected.



5. Hold the handrails while you step onto the running belt and begin walking.

6. Observe the control panel.

The top center **Bar Graph** display shows a graphical representation of the relative incline changes, and if in a program, will show the relative intensity changes that are coming up. The **Text Area** will start showing the workout data such as Distance, Calories, Heart rate (if available), MET and Pace (Minutes per Mile or Minutes per Km). The data displays will start by automatically shifting every 5 seconds.

Heart rate will be displayed in lieu of MET if a valid heart rate is available from a wireless chest strap (not included) or by holding the contact heart rate grips.

When you adjust incline in a workout, the change will affect only the current segment. The program control will resume starting with the next segment. To increase or decrease overall intensity, adjust the speed and/or the program level.

7. Press the **Speed+** - keys to change the belt speed at any time. The right display will show speed.
8. Press the **Incline ▲ ▼** keys to change the incline at any time. The left display will show incline.
9. Press the **STOP** key at any time to stop the workout. **Workout Review** is displayed and the incline returns to 0%.



If the e-stop key is removed during a workout, the drive motor power shuts off immediately, causing the belt to stop. Emergency Stop! is displayed. Replacement of the e-stop key causes **Workout Review** to begin.

When a program is complete the treadmill begins a countdown, 3...2...1 and sounds a tone for each count. The belt slows to a stop, the incline returns to 0% and Workout Review is displayed for the preset time or until you press the **Home** key.

The treadmill returns to *Dormant Mode*.

Stopping the Treadmill

Press **STOP** once to end the workout session and start the Workout Review. The treadmill will perform a controlled belt stop and bring the incline to 0%. The accumulated data will be displayed for the duration configured in Setup for Review Time. Press **STOP** again to exit to Dormant.

The function of the immobilization method: The purpose of immobilizing the treadmill is to prevent unauthorized use. This can be accomplished by removing the e-stop key from the treadmill, un-clipping it from the cord and putting it in a non-accessible place.

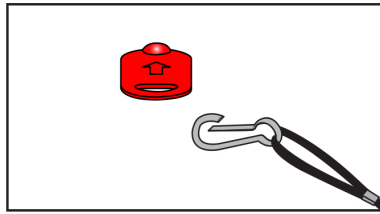

The emergency dismount: Follow the steps listed below if you experience pain, feel faint or need to stop your treadmill in an emergency situation:

1. Grip handrails for support.
2. Step onto the top steps.
3. Pull the e-stop key off the console.

The function of the emergency stop: The e-stop key functions as the emergency stop. In an emergency situation, remove the e-stop key from the treadmill and the running belt will come to a stop.

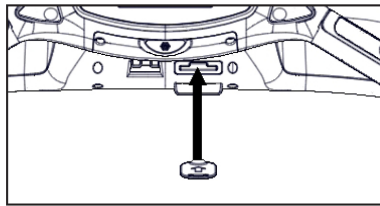

Safety Sentry

Safety Sentry uses display feedback to determine user presence. If a user is not detected within 10 seconds, the display beeps and inquires Run? (LED console) or Are you there? (E3 View console). The treadmill will use every sensor available to determine a user is still on the belt before asking if you are present, then shutting it off. If the user is lighter than 100 lbs. (45 Kg), the motor drive may not be able to determine they are on the belt. In this instance, the treadmill can only rely on the key inputs, or the heart rate to establish your presence. It is advisable for lighter users to take advantage of the wireless heart rate feature to avoid triggering the Safety Sentry.

An unattended, running treadmill can create an unsafe environment for a user. The Safety Sentry feature is intended to allow the treadmill to stop the running belt when the treadmill is unattended. To avoid the treadmill running unattended, follow these steps:

1. At the end of your workout, verify that the running belt is stopped by visually checking the Cybex logo on the running belt, it should not be moving.
2. If the belt is moving, place feet on both sides of the top step and press **STOP** or remove the e-stop key from the treadmill.

Workout Selection

Quick Start

1. Press **Quick Start**.
2. Control speed and incline.

Workout Choices:

Weight Loss

| Name | Levels | Settings |
|------------|--------|---|
| Speed Bump | 10 | Choose goal - Time, distance, or calorie. |
| Rollers | 10 | Choose goal - Time, distance, or calorie. |
| Hills | 10 | Choose goal - Time, distance, or calorie. |
| Peaks | 10 | Choose goal - Time, distance, or calorie. |

Cardio

| Name | Levels | Settings |
|----------------------|--------|---|
| Hill Interval 1:1 | 10 | Choose goal - Time, distance, or calorie. |
| Hill Interval 1:2 | 10 | Choose goal - Time, distance, or calorie. |
| Hill Interval 1:3 | 10 | Choose goal - Time, distance, or calorie. |
| Interval Plus | 10 | Choose goal - Time, distance, or calorie. |
| Heart Rate Control** | N/A | Choose goal - Time, distance, or calorie. |

Tests

| Name | Levels | Settings | Results |
|------------------|------------------------------------|--|---------------------|
| Gerkin Protocol | Walk/run | Weight, age, and gender. | VO ₂ max |
| Army PFT | 2 mile/3.2 k run | Weight, age, gender, and starting speed. | Points |
| Air Force PFT | 1.5 mile/2.4 k run | Weight, age, gender, and starting speed. | Points |
| Navy <5K PRT | 1.5 mile/2.4 k run under 5000 feet | Weight, age, gender, and starting speed. | Points |
| Navy > 5K PRT | 1.5 mile/2.4 k run over 5000 feet | Weight, age, gender, and starting speed. | Points |
| Marines PRT | 3 mile/4.8 k run sea level | Weight, age, gender, and starting speed. | Points |
| Marines 4500 PRT | 3 mile/4.8 k run 4500 feet | Weight, age, gender, and starting speed. | Points |
| One Mile Test | 1 mile/1.6 k walk | Weight, age, gender, and starting speed. | VO ₂ max |

PFT means Physical Fitness Test, PRT means Physical Readiness Test.

See Appendix for workout details

Data Readouts

As you exercise, the unit keeps track of the following data:

- BPM (Beats Per Minute)** Your current heart rate. Heart rate will appear when a signal is introduced. Use the hand grips for Contact Heart rate or wear a Polar® compatible heart rate chest strap.
- Calories** The total accumulated calories burned during your workout. Your weight must be correctly set before beginning your workout for this measurement to be most accurate.
- Calories Per Hour** Calculation of present workload's energy exertion in Calories per Hour.
- Distance** The total accumulated distance, in miles or kilometers, during your workout. Depending on the defaults you've chosen this measurement will show in English or Metric
- Metabolic Equivalent (MET)** Relates to the user's energy expenditure. A MET is a basic unit of measurement that is used to compare relative work between individuals and activities. 'One MET' is the amount of oxygen consumed at rest. For example, two MET would be twice that amount. If an individual were working at four MET he/she would be consuming oxygen at a rate equal to four times their resting consumption. MET can be used to compare walking on a grade with running or even to cycling and other activities.
- Pace** At your current speed, how long it would take to cover a mile (or kilometer), displayed in minutes:seconds.
- Time** The total time you've been working out or time remaining. Display time as **minutes:seconds**.

| | | |
|-------|-----------------|---------------------|
| MM:SS | Minutes:Seconds | 00:01 to 99:99 |
| MMMM | Minutes | 100 minutes or more |

Watt Present workload energy exertion.

Heart Rate Indicator

Contact Heart Rate Lightly hold hand grips on the handlebar ensuring that hands are clean and contact both the front and back sensors of each grip. A heart rate will display in typically 30 seconds or less.

Factors that interfere with heart rate signal:





- hand lotions
- oils or body powder
- excessive dirt
- excessive movement
- body composition

- hydration
- too loose grip
- too tight grip
- resting or leaning on grips

Wireless Heart Rate

To use this feature, a 5 KHz Polar® compatible heart rate transmitter belt (not included) must be worn.

Once the actual heart rate is determined, the LED is blinking to the displayed BPM and the Heart LED lights up. The color of the light represents a scale of low to high target heart rate.

| | | |
|--|-------------|----------------|
|  | Blue | 0 - 69 BPM |
|  | Green | 70 - 93 BPM |
|  | Yellow | 94 - 119 BPM |
|  | Dark Orange | 120 - 169 |
|  | Magenta | 170 and higher |

Meaning of % Grade

A 1% grade is not the same as a 1 degree incline. The % grade is the relationship of the measurement of rise over the measurement of run (also called slope). For example, a 1 foot (meter) rise in height over a length of 100 feet (meters) is a 1% grade. Expressed as a mathematical formula, the grade is calculated as follows: $1 \text{ ft. (m)} / 100 \text{ ft. (m)} = 0.01 = 1\%$

With respect to treadmills, the percent grade is roughly equal to the increase in height (rise) of the treadmill divided by the length (run) of the treadmill.

The degree of incline can be related to % grade by taking the Arctangent of the grade. For instance, 15% grade is equal to 8.53 Degrees ($\text{ArcTan}(.15)=8.53^\circ$). The opposite is true to determine % Grade from Degree of incline ($\text{Tan}(8.53^\circ)=.15$).

Fan Control





The fan defaults to the "OFF" setting. The user can change to "Fan Low", "Fan High", or "Fan Off" setting by pressing the appropriate control key.

E3 View Monitor Screen Options

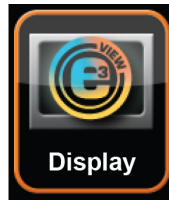
During operation four E3 View Monitor screen options are available.

Press **E3 View Monitor** icon to change screens.



| | | |
|---|-----------|---|
|  | TV + Data | Display video with data at bottom of screen |
|  | TV Only | Display video only |
|  | Data Only | Display data only |
|  | Blank | Screen is blank, video and data are not displayed |

iPod/iPhone Functions

Connecting an iPod/iPhone allows some control through the keypad. The iPod/iPhone will not be charged while connected.

1. Connect iPod/iPhone (not supplied) into the 30 pin connector.
2. Place iPod/iPhone onto the accessory tray.
3. Plug headphones (not supplied) into the console headphone jack.
4. iPod/iPhone Playlist
 - a) Select the iPod/iPhone icon to display the iPod/iPhone navigation screen.

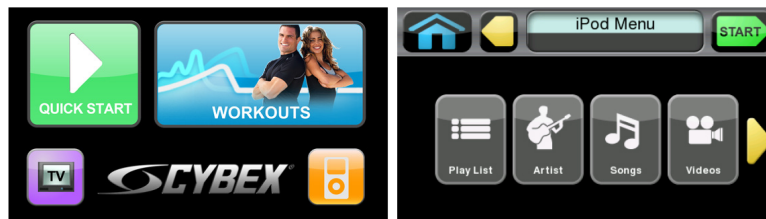

- b) If iPod/iPhone is already playing use the standard iPod/iPhone controls.
- c) If iPod/iPhone is Dormant make a selection from the iPod/iPhone Menu.

Once a selection is made from the iPod/iPhone menu, make further selections until the desired media is found.

CSAFE Port

The CSAFE standard defines a communication protocol and low-voltage DC power source specific to the Fitness Equipment Industry. These RJ-45 phone jacks are provided for use ONLY within the CSAFE protocol.

For more information on CSAFE standard, visit www.fitlinxx.com/csafe.

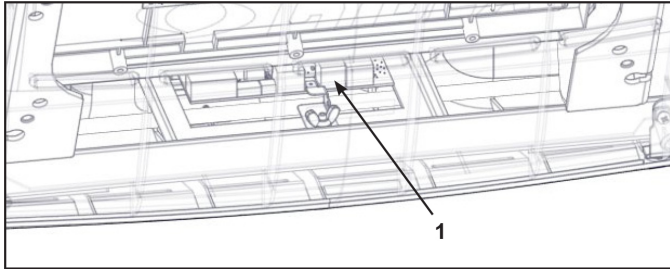

| | Description | Qty. |
|---|------------------|------|
| 1 | CSAFE port (Red) | 1 |

Figure 6: Console CSAFE port location (Inside console)

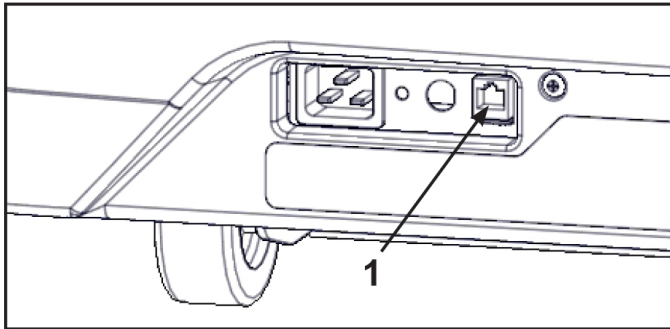

| | Description | Qty. |
|---|-------------|------|
| 1 | CSAFE port | 1 |

Figure 7: Optional CSAFE location (Front of unit)

Log In

When unit is connected to a CSAFE network, the user is prompted to login at startup Enter your club ID#.

Enter your club ID# using the keypad located on the **CardioTouch** screen.



Maintenance

All preventive maintenance activities must be performed on a regular basis. Performing routine preventive maintenance actions can aid in providing safe, trouble-free operation of all Cybex equipment.

Cybex is not responsible for performing regular inspection and maintenance actions for your machines. Instruct all personnel in equipment inspection and maintenance actions and also in accident reporting and recording. Cybex representatives are available to answer any questions that you may have.

Warnings

 Read all warnings in this chapter.

WARNING

For maintenance, service and repair:

- Must be performed by trained service personnel only
- Use only Cybex replacement parts
- Unplug unit before working on it
- Keep water and liquids away from electrical parts.

DANGER

Electrocution hazard. To avoid death or serious injury unplug unit when not in use or when performing maintenance.

WARNING

Equipment hazard. To avoid serious injury or death replace worn or damaged components immediately and keep the equipment out of use until repair is completed.

Clean Unit

WARNING

Shock and electrocution hazard.

- Unplug unit and let sit 10 minutes before cleaning or performing maintenance.
- Electrical charge can remain in unit after unplugging.
- Keep water and liquids away from electrical parts.

Tools Required

- Cleaning solution
- Rubbing alcohol
- Clean Cloth
- Vacuum

After Each Use

Wipe up any liquid spills immediately. After each workout, use a cloth to wipe up any remaining perspiration from the handrails and painted surfaces.

Be careful not to spill or get excessive moisture between the edge of the display panel and the console, as this might create an electrical hazard or cause failure of the electronics.

As Needed

Vacuum any dust or dirt that might accumulate under or around the unit. Cleaning this area should be done as often as indicated in the Service Schedule.

Clean Console

NOTICE

Do not spray cleaning solution directly on the console. Direct spraying could cause damage to the electronics and may void the warranty.

- Spray a mild cleaning agent on a clean cloth.
- Clean the console, accessory tray, and cup holder with a damp cloth.

Clean Base

- Spray a mild cleaning agent on a clean cloth.
- Clean the base of the unit with a damp cloth.

Contact Heart Rate Grips

Clean the grips using a cloth dampened with a cleaning solution containing rubbing alcohol.

Contaminants, such as hand lotions, oils or body powder, may come off on the contact heart rate grips. These can reduce sensitivity and interfere with the heart rate signal. It is recommended that the user have clean hands when using the contact heart rate.

CardioTouch Screen

While in *Dormant Mode* press the **Cybex** logo icon to access the *Lock and Toolbox* options. Press the **Lock screen for cleaning** icon to lock the screen for 10 seconds. The CardioTouch screen will stay locked for 10 seconds to prevent any key presses from being processed. Clean the CardioTouch screen using a soft cloth dampened with a cleaning solution containing rubbing alcohol.

Vacuum Motor Bay

Tools Required

- Phillips screwdriver
 - Clean Cloth
 - Vacuum, with tip for small spaces
1. Loosen, but do not remove the two front cover screws securing the motor cover using a Phillips screwdriver.
 2. Lift the cover straight up; the screws will stay in place.
 3. Vacuum the exposed elevation assembly, drive motor, lower electronics and the surrounding areas.

- Vacuum the fan and heat sink area of the motor controller.

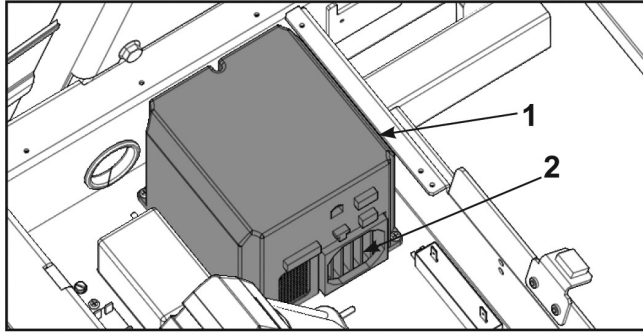

| | Description | Qty. |
|---|------------------|------|
| 1 | Motor controller | 1 |
| 2 | Fan and heatsink | 1 |

- Use a dry cloth for the areas that you can not reach with the vacuum cleaner. If the machine has not been used for some time or is excessively dirty, use a dry cloth to wipe all exposed areas.
- Raise the rear of the treadmill and roll it back from its present position to vacuum the floor area underneath the unit. When finished, return the treadmill to its normal position.

Running Belt

Center and tension the running belt

- Plug the power cord into the power outlet.
- Turn the main power switch to the on (I) position.
- Tap the **Quick Start** icon.
- Press the **Speed +** key to bring the speed up to 5 mph (8 kph). Allow the treadmill to run for a minute. The lateral position of the running belt is correctly centered when the Cybex logo is centered between the inside edges of the two belt tracking slots. If the Cybex logo is not centered between the belt tracking slots, center the running belt with the following procedure.
- Observe the Cybex logo position relative to the belt tracking slots with the treadmill running at 5 mph (8 kph).

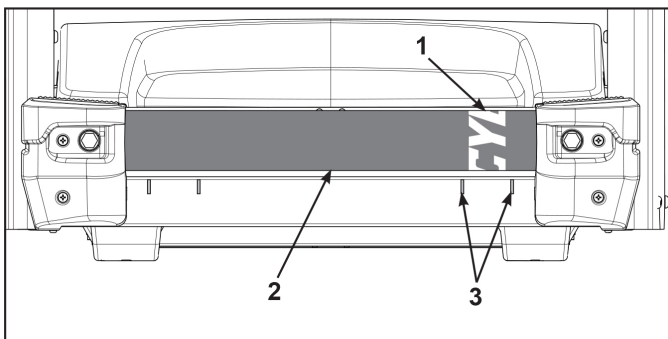

| | Description | Qty. |
|---|--------------------|------|
| 1 | Cybex logo | 1 |
| 2 | Running belt | 1 |
| 3 | Belt tracking slot | 4 |

While centering the running belt choose one bolt to adjust. Do not adjust both bolts.

6. Tighten the rear roller bolt on the side of the treadmill toward which the running belt is moving using a 3/4" socket wrench.

For example: If the running belt moves to the right of the belt tracking slots, tighten the bolt on the right side of the frame, tighten about 1/2 of a turn (clockwise) and wait 30 seconds. If the running belt does not move back to the center of the belt tracking slots, make another adjustment to the same bolt. Once the running belt has been adjusted closer to the center of the belt tracking slots, use about 1/4 of a turn until the running belt has been stabilized.

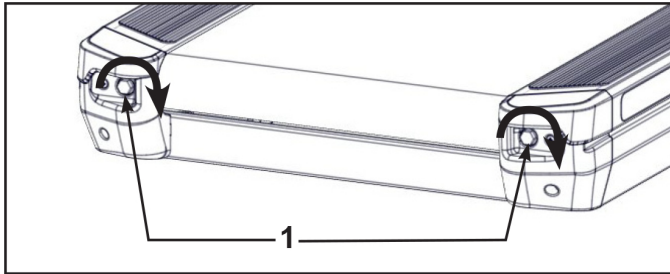

| | Description | Qty. |
|---|------------------|------|
| 1 | Rear roller bolt | 2 |

7. Check the belt tension after the running belt has been centered. Make sure the running belt tension is tight enough so that the running belt does not slip or hesitate when stepped on. Walk on the treadmill at 3.5 - 4 mph (5.6 - 6.4 kph) and every 4th to 5th step throw your weight into your step to feel if the running belt is slipping. If slipping is felt, confirm it is the running belt slipping and not the drive belt. With the hood cover removed, observe movement at the drive belt and front roller.

Do not over tighten the running belt. Over tightening the running belt can cause the belt to stretch and require replacement. Continue procedure until running belt stops slipping.

8. Check running belt for centering position. If running belt is not centered, perform steps 5 and 6.

Check Running Belt and Deck Surfaces

The running belt and deck should be checked periodically for any excessive wear. In an effort to make sure that the running belt operates properly, visually inspect the belt often to make sure that there are no tears or fraying in the belt material. The running belt should be replaced every 15,000 miles (24,140 km). The running deck should be flipped every 15,000 miles (24,140 km) and replaced every 30,000 miles (48,280 km). A service prompt will appear at this interval and the parts will need to be replaced.

Tools Required

Phillips screwdriver

Disconnect external power source

1. Toggle the on/off (I/O) power switch to the off (O) position. The on/off (I/O) power switch is located under the front end of the unit, or on the front right side panel.
2. Unplug the treadmill from the power outlet.

Check the running belt condition

1. Remove the two screws securing the right end cap using a Phillips screwdriver.

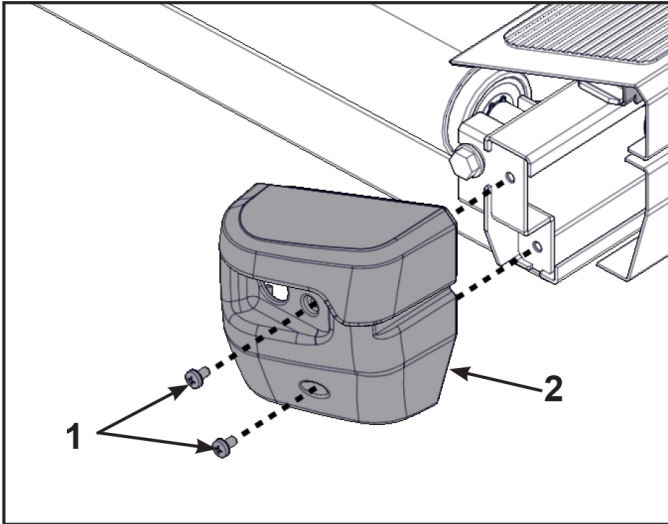

| | Description | Qty. |
|---|---------------|------|
| 1 | Screws | 2 |
| 2 | Right end cap | 1 |

2. Repeat step 1 on page 70 for the left end cap.
3. Inspect the top surface, seam, and edges of the running belt while you roll it by hand. If the belt has any rips or looks excessively worn the belt needs to be replaced. If the running belt and deck need replacement refer to a qualified service technician.
4. Install the screws securing the end caps removed in steps 1 on page 70 and 2 on page 70 using a Phillips screwdriver.

Other Maintenance

Other preventive maintenance activities must be completed by a qualified service technician at the recommended intervals listed in the **Service Schedule** at the end of this chapter. These activities include:

- Flipping or replacing the running deck
- Replacing the running belt

Elevation Motor Lubrication

In time the elevation motor pivot points or tube nut may develop a squeak. Lubricate the upper and lower bolts and the spacers with a small amount of lithium grease. You can buy lithium grease at an auto parts store.

Static Electricity

Depending upon where you live, you may experience dry air, causing a common experience of static electricity. This may be especially true in the winter time. You may notice a static build-up just by walking across a carpet and then touching a metal object. The same can hold true while working out on your treadmill. You may experience a shock due to the build-up of static electricity on your body and the discharge path of the treadmill. If you experience this type of situation, you may want to increase the humidity to a comfortable level through the use of a humidifier.

E3 View Monitor

Cleaning

- Clean with a dust free cloth. For further cleaning, use a soft cloth or paper towel dampened with water. To avoid damage to the surface of the monitor, do not use abrasive or chemical cleaning agents.
- Disinfecting: to avoid damage to the surface, test a small portion of the monitor's cabinet with any disinfectant to verify that the disinfectant will not discolor or soften the enclosure.

Storage or Long Non-Use Periods

When not using product for an extended period of time the product should be disconnected from the Power Supply, TV/Cable Signal Feed, and any Peripheral Devices.

Pixels

Very small red, blue, white or green spots may be visible or may appear on the screen. This is a characteristic of liquid crystal display panels and is not considered a defect for replacement. The liquid crystal panel is built with very high precision technology giving fine picture details. Occasionally, a few non-active pixels may appear on the screen as a fixed point. This does not affect the performance of monitor or merit a warranty claim.

Maintenance

- It is very important to have the unit regularly examined by a qualified technician to ensure the product is fit for use.
- If the unit malfunctions, please refer to a qualified technician for repair or replacement of defective parts immediately. Do not attempt to use the monitor until it has been inspected and repaired by a qualified technician.
- For inspection, installation and servicing, please consult qualified technician.
- Failure to use a manufacturer approved repair technician may void any warranty claims.

Service Wheel (optional)

A service wheel lever is located at the rear end of the unit. This lever will engage a wheel and elevate the rear end of the unit. The treadmill can then be easily moved for cleaning or servicing.

****WARNING****

Shock and electrocution hazard.

- Unplug unit and let sit 10 minutes before cleaning or performing maintenance.
- Electrical charge can remain in unit after unplugging.
- Keep water and liquids away from electrical parts.

Engage service wheel

1. Unplug power cord from power outlet.

- Grasp the service wheel lever and slide to the right and down to lock in place.

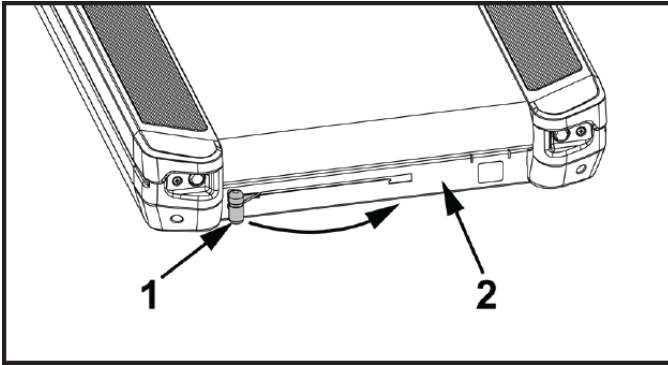

| | Description | Qty. |
|---|---------------------|------|
| 1 | Service wheel lever | 1 |
| 2 | Frame | 1 |

The service wheel will lower and raise the rear foot off the floor.

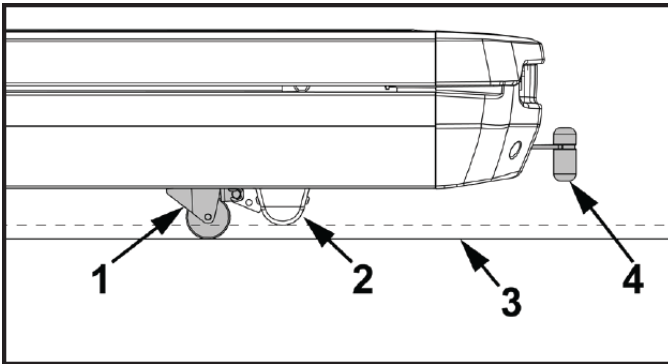

| | Description | Qty. |
|---|---------------------|------|
| 1 | Service wheel | 1 |
| 2 | Rear foot | 2 |
| 3 | Floor | 1 |
| 4 | Service wheel lever | 1 |

- Move treadmill as needed.

Disengage service wheel



WARNING Trip and fall hazard. To avoid injury, make sure service wheel lever is not engaged prior to use.

- Grasp the service wheel lever and slide to the right, lift up, and slide to the left.

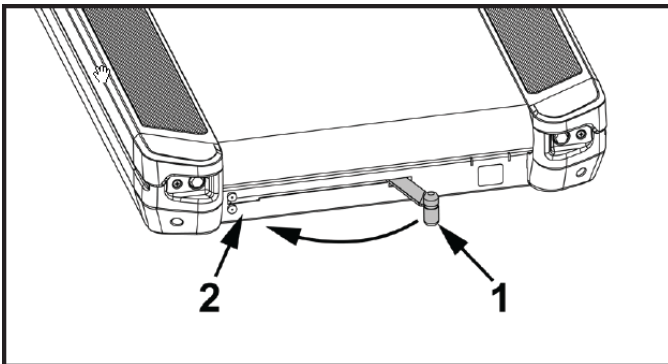

| | Description | Qty. |
|---|---------------------|------|
| 1 | Service wheel lever | 1 |
| 2 | Frame | 1 |



- Plug the power cord into the power outlet.









Service Schedule

All maintenance activities shall be performed by qualified personnel. Failure to do so could result in serious injury.

This is the minimum recommended service.

Determine distance

| | | |
|--|----------------------|--|
|  | CYBEX LOGO | Press and hold Cybex logo for 6 seconds to access Screen Lock and Toolbox . |
|  | LANGUAGE ICON | Press and hold language logo for 6 seconds to access Screen Lock and Toolbox . |

1. Tap the **Access Toolbox** icon to display the **Access to Toolbox** login screen.
2. Enter the sequence:     .
3. Press the **Statistics** icon to access the **Recorded Statistics** screen.
4. Locate and tap the icon for **Treadmill Totals**.
5. Record Distance.
6. Tap the **Back**  icon to return to the **Recorded Statistics** screen.
7. Locate and tap the icon for **Belt** or **Deck**.
8. Record Distance.
9. If replacing the running belt, tap the **Belt** icon, then tap the **New Belt Reset** icon to reset odometer.
10. If replacing the running deck, tap the **Deck** icon, then tap the **New Deck Reset** icon to reset odometer.
11. Exit Set Up Mode by tapping the **Toolbox**  icon, then tap the **Home** icon . The screen will refresh.

First 500 miles (800 km).

Check running belt tension and tracking.

Every 5,000 miles (8,000 km).

1. Check running belt tension and tracking.
2. Vacuum the fan and heat sink area of the motor controller.
3. Move treadmill and vacuum underneath.
4. Use Service wheel, or raise elevation to 15%, carefully roll the treadmill backwards to clean underneath with a dry cloth and vacuum. Return to normal position when done.

Every 15,000 miles (24,140 km).

1. Replace running belt and flip deck.
2. Check elevation assembly and replace worn parts.
3. Lubricate elevation pivot points.

Every 30,000 miles (48,280 km).

Replace running belt and deck.

Customer Service

Product Registration

To register product do the following:.

1. Visit www.cybexintl.com.
2. Locate Product Registration in the Support section.
3. Fill out form completely.
4. Click the **Submit** button to register product.

Contacting Service

Hours of phone service are Monday through Friday from 8:30 a.m. to 6:00 p.m. Eastern Standard Time.

For Cybox customers living in the USA, contact Cybox Customer Service at 888-462-9239.

For Cybox customers living outside the USA, contact Cybox Customer Service at 508-533-4300 or fax 508-533-5183. Email address internationaltechhelp@cybexintl.com

Find information on the web at www.cybexintl.com.

To contact us online go to www.cybexintl.com.

Ordering Parts

To order parts online go to www.cybexintl.com.

To speak with a customer service representative, call 888-462-9239 (for customers living within the USA) or 508-533-4300 (for customers outside the USA).

The following information located on the serial number decal will assist our Cybox representatives in serving you.

- Unit Serial Number, Product Name and Model Number
- Part Description and Part Number if you have it. All parts can be found on the web at www.cybexintl.com
- Shipping Address
- Contact Name
- Include a description of the problem.

In addition to your shipping address and contact name, your account number is helpful but not required. You may also fax orders to 508-533-5183.

Return Material Authorization (RMA)

The Return Material Authorization (RMA) system is used when returning material for placement, repair or credit. The system assures that returned materials are properly handled and analyzed. Follow the following procedures carefully.

Contact your authorized Cybex dealer on all warranty-related matters. Your local Cybex dealer will request a RMA from Cybex, if applicable. Under no circumstances will defective parts or equipment be accepted by Cybex without proper RMA and an Automated Return Service (ARS) label.

Please contact [Cybex Customer Service](#) for the return of any item that is defective.

Provide the technician with a detailed description of the problem you are having or the defect in the item you wish to return. Provide the model and serial number of your Cybex equipment.

At Cybex's discretion, the technician may request that you return the problem part(s) to Cybex for evaluation and repair or replacement. The technician will assign you a RMA number and will send you an ARS label. The ARS label and the RMA numbers must be clearly displayed on the outside of the package that contains the item(s) to be returned. Include the description of the problem, the serial number of the equipment and the name and address of the owner in the package along with the part(s).

Merchandise returned without an RMA number on the outside of the package or shipments sent COD will not be accepted by the Cybex receiving department.

Damaged Parts

Materials damaged in shipment should not be returned for credit. Shipping damages are the responsibility of the carrier (UPS, Federal Express, trucking companies, etc.)

Apparent Damage

Upon receipt of your shipment, check all items carefully. Any damage seen with a visual check must be noted on the freight bill and signed by the carrier's agent. Failure to do so will result in the carriers refusal to honor your damage claim. The carrier will provide you with the required forms for filing such claims.

Concealed Damage

Damage not seen with a visual check upon receipt of a shipment but notices later must be reported to the carrier as soon as possible. Upon discovery of the damage, a written or phone request to the carrier asking them to perform an inspection of the materials must be made within ten days of the delivery date. Keep all shipping containers and packing materials as they will be needed in the inspection process. The carrier will provide you with an inspection report and the necessary forms for filing a concealed damage claim. Concealed damage claim is the carrier's responsibility.

Appendix - Workout Overviews

Speed Bump

This workout uses a series of relatively minor changes in its five-minute core to add an incremental demand. The five-minute core utilizes a baseline incline for two minutes and then increases the incline for added demand and then provides a slightly lower Incline for two-minutes for recovery.

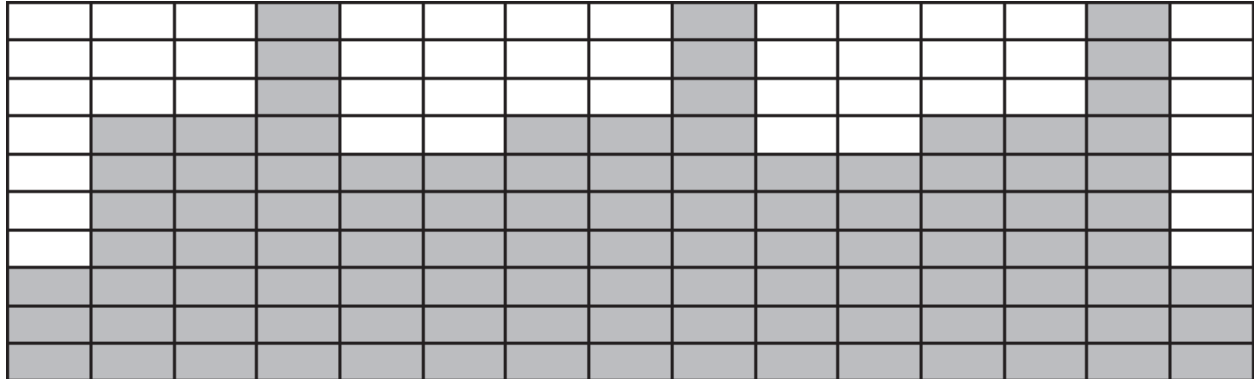

| Time | :30 | :30 | :30 | :30 | 1:00 | 1:00 | 1:00 | 1:00 | 1:00 | :30 | :30 | :30 | :30 |
|---------|---------|-----|-----|-----|---------------|------|------|------|------|-----------|-----|-----|-----|
| | Warm Up | | | | Core Segments | | | | | Cool Down | | | |
| Incline | 1 | 2 | 3 | 4 | 1 | 2 | 3 | 4 | 5 | 1 | 2 | 3 | 4 |
| 10 | 2 | 3 | 3 | 5 | 10 | 10 | 14 | 9 | 9 | 0 | 0 | 0 | 0 |
| 9 | 2 | 3 | 3 | 5 | 9 | 9 | 12 | 8 | 8 | 0 | 0 | 0 | 0 |
| 8 | 2 | 2 | 3 | 4 | 8 | 8 | 10 | 7 | 7 | 0 | 0 | 0 | 0 |
| 7 | 2 | 2 | 3 | 4 | 7 | 7 | 9 | 6 | 6 | 0 | 0 | 0 | 0 |
| 6 | 1 | 2 | 2 | 3 | 6 | 6 | 7 | 5 | 5 | 0 | 0 | 0 | 0 |
| 5 | 1 | 2 | 2 | 3 | 5 | 5 | 6 | 4 | 4 | 0 | 0 | 0 | 0 |
| 4 | 1 | 1 | 2 | 2 | 4 | 4 | 5 | 3 | 3 | 0 | 0 | 0 | 0 |
| 3 | 1 | 1 | 2 | 2 | 3 | 3 | 4 | 2 | 2 | 0 | 0 | 0 | 0 |
| 2 | 1 | 1 | 1 | 2 | 2 | 2 | 3 | 1 | 1 | 0 | 0 | 0 | 0 |
| 1 | 1 | 1 | 1 | 2 | 1 | 1 | 2 | 0 | 0 | 0 | 0 | 0 | 0 |

Rollers

This workout uses an eight minute core intended to mimic variety in terrain that might be found on a hilly outdoor run. The eight minute core is composed of four segments. The baseline segment is two minutes in length and is followed by two two-minute segments of increase Incline before returning to the intermediate incline for two minutes.

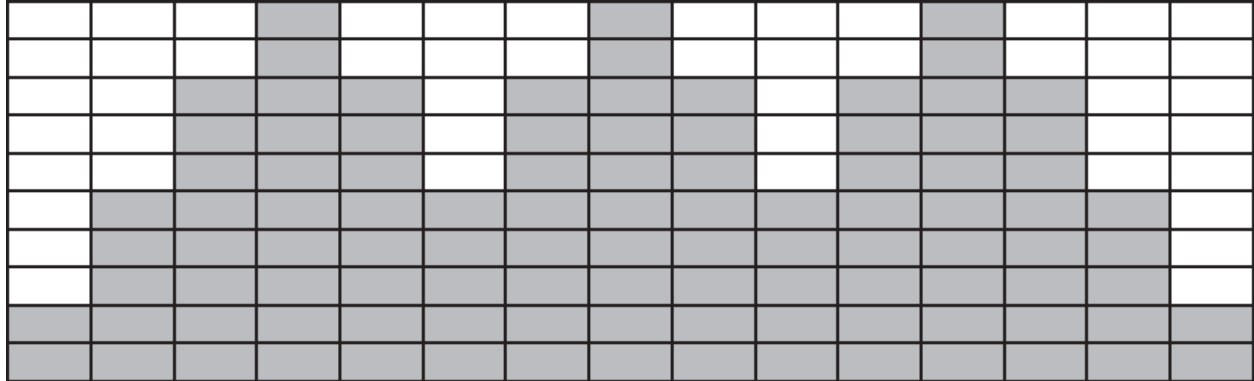

| Time | :30 | :30 | :30 | :30 | 2:00 | 2:00 | 2:00 | 2:00 | :30 | :30 | :30 | :30 |
|---------|---------|-----|-----|-----|---------------|------|------|------|-----------|-----|-----|-----|
| | Warm Up | | | | Core Segments | | | | Cool Down | | | |
| Incline | 1 | 2 | 3 | 4 | 1 | 2 | 3 | 4 | 1 | 2 | 3 | 4 |
| 10 | 1 | 2 | 2 | 3 | 4 | 6 | 8 | 6 | 0 | 0 | 0 | 0 |
| 9 | 1 | 1 | 2 | 2 | 3 | 6 | 8 | 5 | 0 | 0 | 0 | 0 |
| 8 | 1 | 1 | 2 | 2 | 3 | 5 | 8 | 5 | 0 | 0 | 0 | 0 |
| 7 | 1 | 1 | 1 | 2 | 2 | 5 | 7 | 4 | 0 | 0 | 0 | 0 |
| 6 | 1 | 1 | 1 | 2 | 2 | 4 | 7 | 4 | 0 | 0 | 0 | 0 |
| 5 | 0 | 0 | 1 | 1 | 1 | 4 | 7 | 3 | 0 | 0 | 0 | 0 |
| 4 | 0 | 0 | 1 | 1 | 1 | 3 | 6 | 3 | 0 | 0 | 0 | 0 |
| 3 | 0 | 0 | 0 | 0 | 0 | 3 | 6 | 3 | 0 | 0 | 0 | 0 |
| 2 | 0 | 0 | 0 | 0 | 0 | 2 | 6 | 2 | 0 | 0 | 0 | 0 |
| 1 | 0 | 0 | 0 | 0 | 0 | 2 | 5 | 2 | 0 | 0 | 0 | 0 |

Hills

This workout uses a six-minute core utilizing one minute segments with mild Incline changes and two relative peak segments followed by relative rest segments.

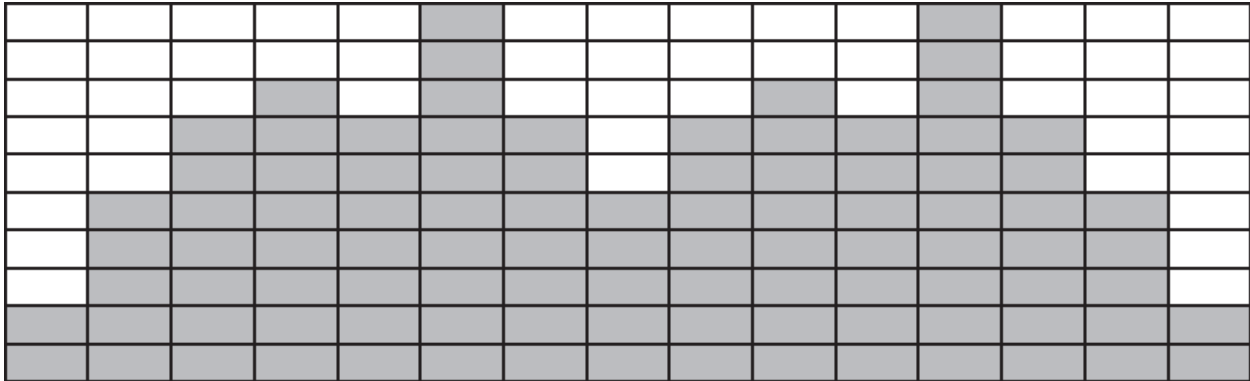

| Time | :30 | :30 | :30 | :30 | 1:00 | 1:00 | 1:00 | 1:00 | 1:00 | 1:00 | :30 | :30 | :30 | :30 |
|---------|---------|-----|-----|-----|---------------|------|------|------|------|------|-----------|-----|-----|-----|
| | Warm Up | | | | Core Segments | | | | | | Cool Down | | | |
| Incline | 1 | 2 | 3 | 4 | 1 | 2 | 3 | 4 | 5 | 6 | 1 | 2 | 3 | 4 |
| 10 | 3 | 3 | 5 | 6 | 8 | 10 | 12 | 10 | 15 | 10 | 0 | 0 | 0 | 0 |
| 9 | 2 | 3 | 4 | 5 | 7 | 9 | 12 | 9 | 14 | 9 | 0 | 0 | 0 | 0 |
| 8 | 2 | 3 | 3 | 5 | 6 | 8 | 11 | 8 | 13 | 8 | 0 | 0 | 0 | 0 |
| 7 | 2 | 2 | 3 | 4 | 5 | 7 | 10 | 7 | 12 | 7 | 0 | 0 | 0 | 0 |
| 6 | 1 | 2 | 2 | 3 | 4 | 6 | 9 | 6 | 11 | 6 | 0 | 0 | 0 | 0 |
| 5 | 1 | 1 | 2 | 2 | 3 | 5 | 8 | 5 | 10 | 5 | 0 | 0 | 0 | 0 |
| 4 | 1 | 1 | 1 | 2 | 2 | 4 | 7 | 4 | 9 | 4 | 0 | 0 | 0 | 0 |
| 3 | 0 | 0 | 1 | 1 | 1 | 3 | 6 | 3 | 8 | 3 | 0 | 0 | 0 | 0 |
| 2 | 0 | 0 | 0 | 0 | 0 | 2 | 5 | 3 | 7 | 3 | 0 | 0 | 0 | 0 |
| 1 | 0 | 0 | 0 | 0 | 0 | 2 | 4 | 2 | 6 | 2 | 0 | 0 | 0 | 0 |

Peaks

This workout uses a nine minute core where the incline increases every minute for the first five minutes. After the fifth minute of the core workout, the incline is reduced each minute. This workout uses continuous and gradual changes to give the user time to acclimate to demand and recover without large perceived changes in the effort required.

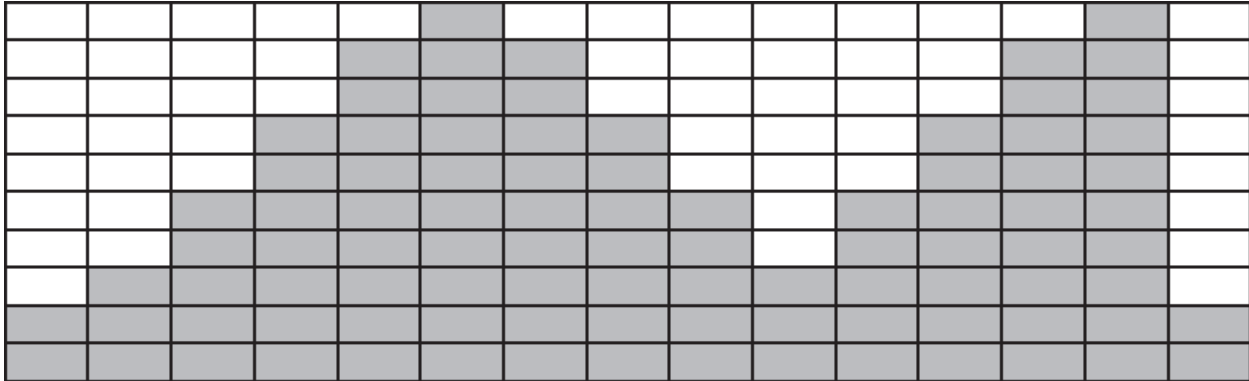

| Time | :30 | :30 | :30 | :30 | 1:00 | 1:00 | 1:00 | 1:00 | 1:00 | 1:00 | 1:00 | 1:00 | 1:00 | :30 | :30 | :30 | :30 | |
|-----------|---------|-----|-----|-----|---------------|------|------|------|------|------|------|------|------|-----|-----------|-----|-----|--|
| | Warm Up | | | | Core Segments | | | | | | | | | | Cool Down | | | |
| Incline | 1 | 2 | 3 | 4 | 1 | 2 | 3 | 4 | 5 | 6 | 7 | 8 | 9 | 1 | 2 | 3 | 4 | |
| 10 | 2 | 2 | 3 | 4 | 5 | 8 | 11 | 13 | 15 | 13 | 11 | 8 | 5 | 0 | 0 | 0 | 0 | |
| 9 | 1 | 2 | 2 | 3 | 4 | 7 | 10 | 12 | 14 | 12 | 10 | 7 | 4 | 0 | 0 | 0 | 0 | |
| 8 | 1 | 2 | 2 | 3 | 4 | 6 | 9 | 11 | 13 | 11 | 9 | 6 | 4 | 0 | 0 | 0 | 0 | |
| 7 | 1 | 1 | 2 | 2 | 3 | 5 | 8 | 10 | 12 | 10 | 8 | 5 | 3 | 0 | 0 | 0 | 0 | |
| 6 | 1 | 1 | 2 | 2 | 3 | 5 | 7 | 9 | 11 | 9 | 7 | 5 | 3 | 0 | 0 | 0 | 0 | |
| 5 | 1 | 1 | 1 | 2 | 2 | 4 | 6 | 8 | 10 | 8 | 6 | 4 | 2 | 0 | 0 | 0 | 0 | |
| 4 | 1 | 1 | 1 | 2 | 2 | 3 | 5 | 7 | 9 | 7 | 5 | 3 | 2 | 0 | 0 | 0 | 0 | |
| 3 | 1 | 1 | 1 | 2 | 2 | 3 | 4 | 6 | 8 | 6 | 4 | 3 | 2 | 0 | 0 | 0 | 0 | |
| 2 | 0 | 0 | 1 | 1 | 1 | 2 | 3 | 5 | 7 | 5 | 3 | 2 | 1 | 0 | 0 | 0 | 0 | |
| 1 | 0 | 0 | 0 | 0 | 0 | 1 | 2 | 4 | 6 | 4 | 2 | 1 | 0 | 0 | 0 | 0 | 0 | |

Hill Interval 1:1

This workout is designed to increase capability by alternating two minute work segments with two minutes of relative rest. The intensity of rest periods is greater here than in Hill Interval 1:2 as is the duration of the work interval making this workout more demanding than Hill Interval 1:2.

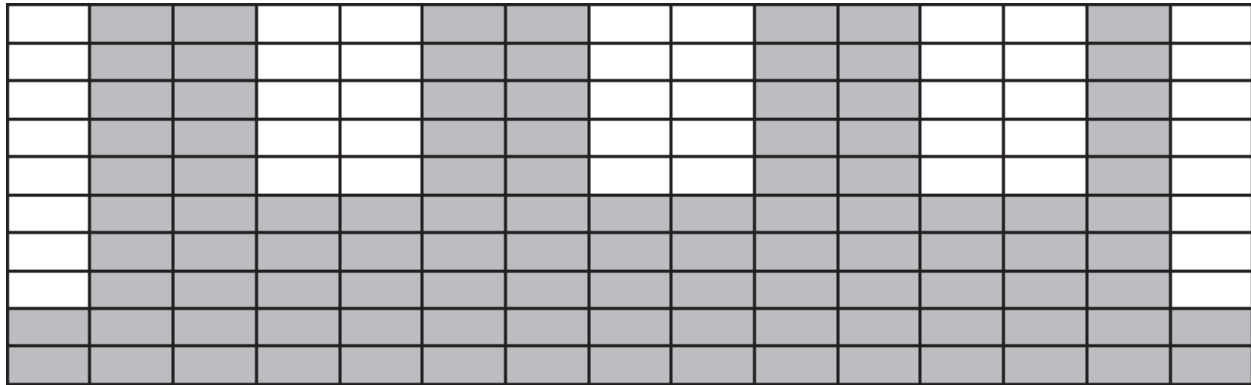

| Time | :30 | :30 | :30 | :30 | 1:00 | 1:00 | 1:00 | 1:00 | :30 | :30 | :30 | :30 |
|---------|---------|-----|-----|-----|---------------|------|------|------|-----------|-----|-----|-----|
| | Warm Up | | | | Core Segments | | | | Cool Down | | | |
| Incline | 1 | 2 | 3 | 4 | 1 | 2 | 3 | 4 | 1 | 2 | 3 | 4 |
| 10 | 3 | 5 | 6 | 8 | 11 | 11 | 6 | 6 | 0 | 0 | 0 | 0 |
| 9 | 3 | 4 | 6 | 8 | 10 | 10 | 5 | 5 | 0 | 0 | 0 | 0 |
| 8 | 3 | 4 | 5 | 7 | 9 | 9 | 5 | 5 | 0 | 0 | 0 | 0 |
| 7 | 3 | 3 | 5 | 6 | 8 | 8 | 4 | 4 | 0 | 0 | 0 | 0 |
| 6 | 2 | 3 | 4 | 5 | 7 | 7 | 4 | 4 | 0 | 0 | 0 | 0 |
| 5 | 2 | 3 | 3 | 5 | 6 | 6 | 3 | 3 | 0 | 0 | 0 | 0 |
| 4 | 2 | 2 | 3 | 4 | 5 | 5 | 3 | 3 | 0 | 0 | 0 | 0 |
| 3 | 1 | 2 | 2 | 3 | 4 | 4 | 2 | 2 | 0 | 0 | 0 | 0 |
| 2 | 1 | 1 | 2 | 2 | 3 | 3 | 2 | 2 | 0 | 0 | 0 | 0 |
| 1 | 1 | 1 | 1 | 2 | 2 | 2 | 1 | 1 | 0 | 0 | 0 | 0 |

Hill Interval 1:2

This workout is designed for to through a one minute work interval at a high incline followed by a two minute rest interval at a substantially lower incline. Given the lower incline and longer rest intervals this workout is less intense than Hill Interval 1:1.

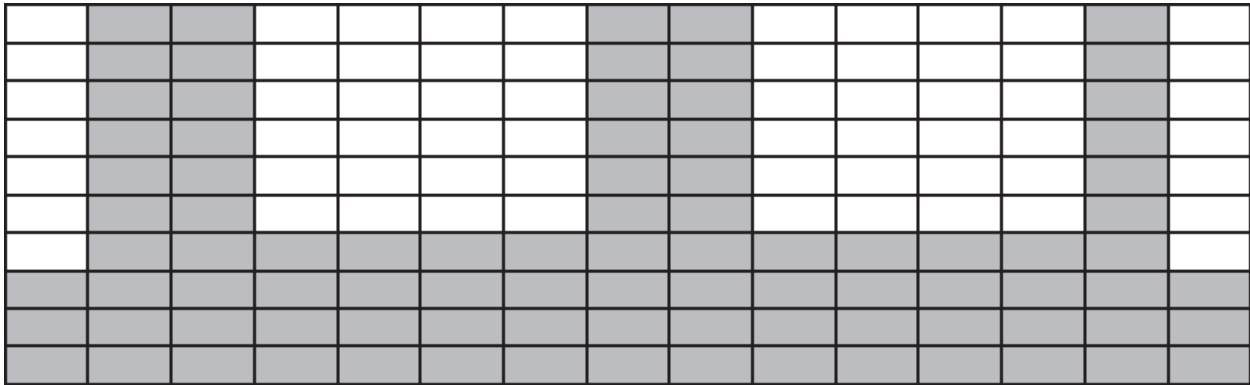

| Time | :30 | :30 | :30 | :30 | :30 | :30 | :30 | :30 | :30 | :30 | :30 | :30 | :30 | :30 |
|---------|---------|-----|-----|-----|---------------|-----|-----|-----|-----|-----|-----------|-----|-----|-----|
| | Warm Up | | | | Core Segments | | | | | | Cool Down | | | |
| Incline | 1 | 2 | 3 | 4 | 1 | 2 | 3 | 4 | 5 | 6 | 1 | 2 | 3 | 4 |
| 10 | 3 | 5 | 6 | 8 | 11 | 11 | 4 | 4 | 4 | 4 | 0 | 0 | 0 | 0 |
| 9 | 3 | 4 | 6 | 8 | 10 | 10 | 3 | 3 | 3 | 3 | 0 | 0 | 0 | 0 |
| 8 | 3 | 4 | 5 | 7 | 9 | 9 | 3 | 3 | 3 | 3 | 0 | 0 | 0 | 0 |
| 7 | 3 | 3 | 5 | 6 | 8 | 8 | 3 | 3 | 3 | 3 | 0 | 0 | 0 | 0 |
| 6 | 2 | 3 | 4 | 5 | 7 | 7 | 2 | 2 | 2 | 2 | 0 | 0 | 0 | 0 |
| 5 | 2 | 3 | 3 | 5 | 6 | 6 | 2 | 2 | 2 | 2 | 0 | 0 | 0 | 0 |
| 4 | 2 | 2 | 3 | 4 | 5 | 5 | 2 | 2 | 2 | 2 | 0 | 0 | 0 | 0 |
| 3 | 1 | 2 | 2 | 3 | 4 | 4 | 1 | 1 | 1 | 1 | 0 | 0 | 0 | 0 |
| 2 | 1 | 1 | 2 | 2 | 3 | 3 | 1 | 1 | 1 | 1 | 0 | 0 | 0 | 0 |
| 1 | 1 | 1 | 1 | 2 | 2 | 2 | 1 | 1 | 1 | 1 | 0 | 0 | 0 | 0 |

Hill Interval 1:3

This workout utilizes a one minute work interval followed by a three minute rest interval. The rest intervals are of a higher incline than those found in the other Hill Interval workouts, and therefore require a longer recovery period.

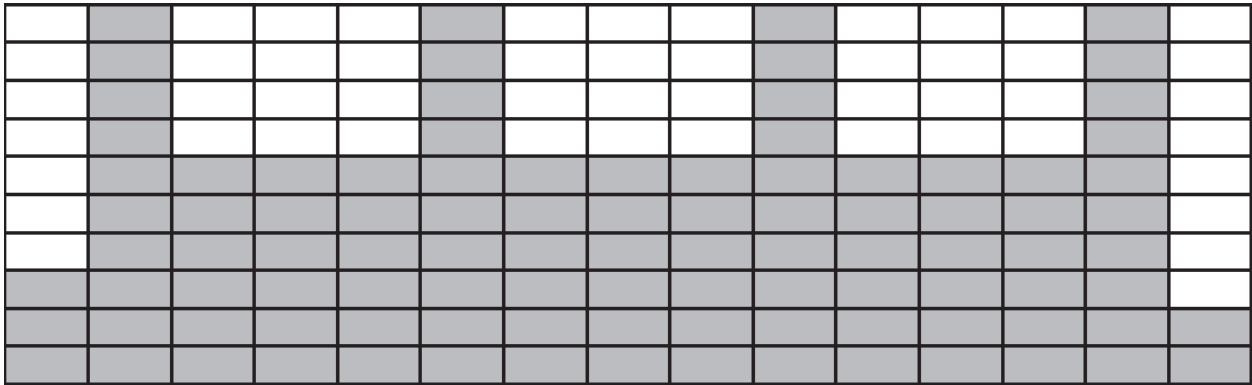

| Time | :30 | :30 | :30 | :30 | 1:00 | 1:00 | 1:00 | 1:00 | 1:00 | 1:00 | 1:00 | 1:00 | :30 | :30 | :30 | :30 |
|---------|---------|-----|-----|-----|---------------|------|------|------|------|------|------|------|-----------|-----|-----|-----|
| | Warm Up | | | | Core Segments | | | | | | | | Cool Down | | | |
| Incline | 1 | 2 | 3 | 4 | 1 | 2 | 3 | 4 | 5 | 6 | 7 | 8 | 1 | 2 | 3 | 4 |
| 10 | 3 | 5 | 6 | 8 | 11 | 7 | 7 | 7 | 11 | 7 | 7 | 7 | 0 | 0 | 0 | 0 |
| 9 | 3 | 4 | 6 | 8 | 10 | 7 | 7 | 7 | 10 | 7 | 7 | 7 | 0 | 0 | 0 | 0 |
| 8 | 3 | 4 | 5 | 7 | 9 | 6 | 6 | 6 | 9 | 6 | 6 | 6 | 0 | 0 | 0 | 0 |
| 7 | 3 | 3 | 5 | 6 | 8 | 5 | 5 | 5 | 8 | 5 | 5 | 5 | 0 | 0 | 0 | 0 |
| 6 | 2 | 3 | 4 | 5 | 7 | 5 | 5 | 5 | 7 | 5 | 5 | 5 | 0 | 0 | 0 | 0 |
| 5 | 2 | 3 | 3 | 5 | 6 | 4 | 4 | 4 | 6 | 4 | 4 | 4 | 0 | 0 | 0 | 0 |
| 4 | 2 | 2 | 3 | 4 | 5 | 3 | 3 | 3 | 5 | 3 | 3 | 3 | 0 | 0 | 0 | 0 |
| 3 | 1 | 2 | 2 | 3 | 4 | 3 | 3 | 3 | 4 | 3 | 3 | 3 | 0 | 0 | 0 | 0 |
| 2 | 1 | 1 | 2 | 2 | 3 | 2 | 2 | 2 | 3 | 2 | 2 | 2 | 0 | 0 | 0 | 0 |
| 1 | 1 | 1 | 1 | 2 | 2 | 1 | 1 | 1 | 2 | 1 | 1 | 1 | 0 | 0 | 0 | 0 |

Interval Plus

This workout is designed to maintain a high total demand using two four-minute segments of alternating incline. This allows prolonged intervals that take advantage of long-term energy systems and total aerobic capability when associated with speeds that require a high sustained cardiovascular demand.

| | | | | | | | | | | | | | | |
|--|--|--|--|--|--|--|--|--|--|--|--|--|--|--|
| | | | | | | | | | | | | | | |
| | | | | | | | | | | | | | | |
| | | | | | | | | | | | | | | |
| | | | | | | | | | | | | | | |
| | | | | | | | | | | | | | | |
| | | | | | | | | | | | | | | |
| | | | | | | | | | | | | | | |
| | | | | | | | | | | | | | | |
| | | | | | | | | | | | | | | |
| | | | | | | | | | | | | | | |
| | | | | | | | | | | | | | | |
| | | | | | | | | | | | | | | |
| | | | | | | | | | | | | | | |
| | | | | | | | | | | | | | | |
| | | | | | | | | | | | | | | |
| | | | | | | | | | | | | | | |

| Time | :30 | :30 | :30 | :30 | 2:00 | 2:00 | 2:00 | 2:00 | :30 | :30 | :30 | :30 |
|---------|---------|-----|-----|-----|---------------|------|------|------|-----------|-----|-----|-----|
| | Warm Up | | | | Core Segments | | | | Cool Down | | | |
| Incline | 1 | 2 | 3 | 4 | 1 | 2 | 3 | 4 | 1 | 2 | 3 | 4 |
| 10 | 2 | 3 | 3 | 5 | 11 | 11 | 9 | 9 | 0 | 0 | 0 | 0 |
| 9 | 2 | 3 | 3 | 5 | 10 | 10 | 8 | 8 | 0 | 0 | 0 | 0 |
| 8 | 2 | 3 | 3 | 5 | 9 | 9 | 7 | 7 | 0 | 0 | 0 | 0 |
| 7 | 2 | 2 | 3 | 4 | 8 | 8 | 6 | 6 | 0 | 0 | 0 | 0 |
| 6 | 2 | 2 | 3 | 4 | 7 | 7 | 5 | 5 | 0 | 0 | 0 | 0 |
| 5 | 2 | 2 | 3 | 4 | 6 | 6 | 4 | 4 | 0 | 0 | 0 | 0 |
| 4 | 2 | 2 | 3 | 4 | 5 | 5 | 3 | 3 | 0 | 0 | 0 | 0 |
| 3 | 1 | 2 | 2 | 3 | 4 | 4 | 2 | 2 | 0 | 0 | 0 | 0 |
| 2 | 0 | 0 | 1 | 2 | 3 | 3 | 1 | 1 | 0 | 0 | 0 | 0 |
| 1 | 0 | 0 | 0 | 0 | 2 | 2 | 0 | 0 | 0 | 0 | 0 | 0 |

Heart Rate Control

 **Note:** This workout requires the user to wear a 5 KHz Polar® or compatible heart rate transmitter belt. The Heart Rate Control workout (HRC) cannot be selected on the control console unless it detects a heart rate signal. The HRC workout will not work with the cardio touch contact heart rate system.

After selecting the HRC workout, the treadmill will prompt you for workout time, weight, age, and target heart rate. Your age is required to estimate the proper range of heart rates. The target heart rate is calculated by the formula: $208 - (0.7 \times \text{Age})$. You will then have the option of adjusting the suggested target heart rate selected either up or down. Select a target heart rate which will allow you to exercise comfortably and safely while at the same time allowing you to reach your training goals. If you are unsure of what to select as your target, consult your physician or a physical training professional. After starting the HRC workout, the treadmill will attempt raise your heart rate to your target within 3 to 5 minutes. The treadmill will emphasize using elevation of the treadmill deck first to achieve higher workloads and thus higher heart rates; this is done to maximize the use of a walking gait, which is safer and more comfortable for many users. As a result, many users will spend nearly the entire workout at elevation up to 12% grade. After reaching your target, the treadmill will attempt to keep you there within 5 beats per min. As you tire, the treadmill will compensate by reducing elevation, speed or both. A two-minute cool-down is built in at the end of the workout.

Method of HRC workout:

User selects heart rate target in the initial start of workout or accepts the suggested target of the formula: $208 - (0.7 \times \text{Age})$. This target heart rate is extremely important for more reasons than just the establishment of the target itself. It also makes an assumption of the general fitness level and controls several aspects of how quickly the elevation and speed will be adjusted. As an example, the starting speed for a selected target of 120 bpm (beats per minute) will be 2 mph. The starting speed for a selected target of 140 bpm will be 3.5 mph. In between those selected targets the starting speed will be proportional to the difference between 2 to 3.5. The workout will also be modified depending on what the selected target is at the start of the workout. This means someone with a higher selected target will get faster changes in speed and grade than someone with a lower target. This has the effect of getting the more fit user to their selected target faster without overshooting the target for someone with a lower fitness level. After the starting speed is attained by the treadmill, it will then increase the elevation every 15 seconds up to 12% grade or until the computer senses that the user is getting close to approaching their target heart rate. Since the control is somewhat predictive in nature, it will leave ample room for the user's heart rate to catch up to the increasing load. If the target heart rate is not attained at the load level of the start speed at 12% grade, then the treadmill will start increasing speed every 15 seconds up to 4 mph or until the computer senses that the user is getting close to approaching their target heart rate. If the user is still not at the target, the treadmill will increase speed to 5 mph and drop the elevation down to 8% grade. This is done because the speeds between 4 and 5 are difficult for the user because it is too slow to jog and too fast for many to walk. The drop in elevation compensates somewhat for the larger increase in speed. The system will then increase the speed of the belt every 15 seconds up to the maximum speed of the treadmill or until the computer senses that the user is getting close to approaching their target heart rate. At any time if the users heart rate exceeds the target, the load will

be decreased in the same order it was increased to ensure that the rate is stabilized at or below the target. When the time period is reached that is two minutes before the selected total time of the workout, the system will go into the cool down mode. This cool down will be similar to the cool down protocols in all the other workouts on the treadmill.

During the control period, the user has limited control over speed and elevation. Within the initial elevation climb segment up to 12 % grade, the users may vary elevation but not speed. Within the other segments the user can vary speed but not elevation. The user's selections are not persistent, however. At the next 15-second mark, the controller as described above will generally choose a new speed or elevation. The user is in fact advancing or retarding the action of the servo.

If at any time the heart rate signal is lost, the system will make no changes in load until such time as the HR signal is regained. If the heart rate signal continues to be lost (no stable HR) for a time period exceeding one minute, then start the cool down profile regardless of what the time period is.

Gerkin Protocol

Workout Overview

This workout was designed to predict the VO_2 max using the Gerkin protocol. This test is used by the International Association of Firefighters to evaluate fitness level.

 **Note:** This workout requires the user to wear a 5 KHz Polar® or compatible heart rate transmitter belt.

The speed range of the workout includes walking speeds at 3 MPH then increases to 4.5 MPH or more during the middle stages. It returns to 3 MPH during the cool down session.

Elevation is used during the second stage of the test. It starts at a 2% grade and can increase from there.

Input information:

- Age
- Weight
- Gender
- Heart rate (5 KHz Polar® compatible wireless chest strap required)

Test procedure:

1. 3 minute warm-up at 0% grade, 3 mph.
2. Stage 1 – 1 minute, 0% grade, 4.5 mph. Walk or run. Heart rate is recorded during the last 15 seconds of each stage.
3. Stage 2 – 1 minute, 2% grade, 4.5 mph.
 - Speed and grade increases now alternate. At odd numbered stages, speed increases by 0.5 mph. At even numbered stages, grade increases 2%.
 - If heart rate is 85% or above, the stage is recorded, but the test continues for another 15 seconds with no increase in grade or speed.
 - If heart rate remains above 85%, the test is terminated, and the last stage number is entered.
 - If heart rate falls to or below 85%, speed or gradient is increased on the next minute boundary.
 - Once the 85% threshold is exceeded or makes it to the 11th minute, the evaluation is ended and the final stage is entered.
4. 3 minute Cool-down – 0% grade, 3 mph.
5. Take heart rate and record one minute after the end of the test. (Taken as a final reading and to monitor HR stabilizing).

Army

Workout Overview

The user controls the speed as needed to reach the goal. A point value will be given at the completion of the test. This workout was designed by the Army to test, evaluate, and measure fitness levels. The goal is to complete the set distance of 2.0 miles (3.2 km) in the least amount of time.

Input information:

- Age
- Weight
- Gender
- Starting Speed

Male

| | Score | | | | | | | | | |
|-------|-------|-------|-------|-------|-------|-------|-------|-------|-------|-------|
| Age | 100 | 90 | 80 | 70 | 60 | 50 | 40 | 30 | 20 | 10 |
| 17-21 | 13:00 | 13:42 | 14:24 | 15:12 | 15:54 | 16:36 | 17:18 | 18:06 | 18:48 | 19:30 |
| 22-26 | 13:00 | 13:54 | 14:48 | 15:42 | 16:36 | 17:30 | 18:24 | 19:18 | 20:12 | 21:06 |
| 27-31 | 13:18 | 14:12 | 15:06 | 16:06 | 17:00 | 17:54 | 18:48 | 19:48 | 20:42 | 21:36 |
| 32-36 | 13:18 | 14:24 | 15:30 | 16:36 | 17:42 | 18:48 | 19:54 | 21:00 | 22:06 | 23:12 |
| 37-41 | 13:36 | 14:48 | 16:00 | 17:06 | 18:18 | 19:30 | 20:42 | 21:48 | 23:00 | 48:12 |
| 42-46 | 14:06 | 15:12 | 16:24 | 17:36 | 18:42 | 19:48 | 21:00 | 22:06 | 23:18 | 24:24 |
| 47-51 | 14:24 | 15:42 | 16:54 | 18:12 | 19:30 | 20:48 | 22:00 | 23:18 | 24:36 | 25:54 |
| 52-56 | 14:42 | 16:00 | 16:54 | 18:30 | 19:48 | 21:00 | 22:18 | 23:36 | 24:54 | 26:12 |
| 57-61 | 15:18 | 16:24 | 17:36 | 18:42 | 19:54 | 21:06 | 22:12 | 23:18 | 24:30 | 25:36 |
| 62+ | 15:42 | 16:48 | 17:48 | 18:54 | 20:00 | 21:06 | 22:12 | 23:12 | 24:18 | 25:24 |

Female

| | Score | | | | | | | | | |
|-------|-------|-------|-------|-------|-------|-------|-------|-------|-------|-------|
| Age | 100 | 90 | 80 | 70 | 60 | 50 | 40 | 30 | 20 | 10 |
| 17-21 | 15:36 | 16:24 | 17:12 | 18:06 | 18:54 | 19:42 | 20:30 | 21:24 | 22:12 | 23:00 |
| 22-26 | 15:36 | 16:36 | 17:36 | 18:36 | 19:36 | 20:36 | 21:36 | 22:36 | 23:36 | 24:36 |
| 27-31 | 15:48 | 17:00 | 18:06 | 19:18 | 20:30 | 21:42 | 22:48 | 24:00 | 25:12 | 26:24 |
| 32-36 | 15:54 | 17:18 | 18:48 | 20:12 | 21:42 | 23:06 | 24:36 | 26:00 | | |
| 37-41 | 17:00 | 18:24 | 19:54 | 21:18 | 22:42 | 24:06 | 25:30 | | | |
| 42-46 | 17:24 | 18:54 | 20:30 | 22:06 | 23:42 | 25:12 | | | | |

| | Score | | | | | | | | | |
|------------|--------------|-----------|-----------|-----------|-----------|-----------|-----------|-----------|-----------|-----------|
| Age | 100 | 90 | 80 | 70 | 60 | 50 | 40 | 30 | 20 | 10 |
| 47-51 | 17:36 | 19:12 | 20:48 | 22:24 | 24:00 | 25:36 | | | | |
| 52-56 | 19:00 | 20:18 | 21:42 | 23:00 | 24:24 | 25:48 | | | | |
| 57-61 | 19:42 | 21:00 | 22:18 | 23:30 | 24:48 | 26:06 | | | | |
| 62+ | 20:00 | 21:18 | 22:30 | 23:42 | 25:00 | 26:12 | | | | |

Air Force

Workout Overview

This workout was designed by the Air Force to test, evaluate, and measure fitness levels. The goal is to complete the set distance of 1.5 miles (2.4 km) in the least amount of time. The user controls the speed as needed to reach the goal. A point value will be given at the completion of the test.

Input information:

- Age
- Weight
- Gender
- Starting Speed

Male

| Males <25 and Males 25-29 | | | Males 30-34 and Males 35-39 | | | Males 40-44 and Males 45-49 | | |
|---------------------------|--------------------------------------|------------------|-----------------------------|--------------------------------------|------------------|-----------------------------|--------------------------------------|------------------|
| 1.5 Mile RunTime (min.) | VO2 (ml/kg/min) Submaximal Estimates | Component-Points | 1.5 Mile RunTime (min.) | VO2 (ml/kg/min) Submaximal Estimates | Component-Points | 1.5 Mile RunTime (min.) | VO2 (ml/kg/min) Submaximal Estimates | Component-Points |
| <9:36 | >54 | 50.00 | <9:48 | 53 | 50.00 | <10:24 | >50 | 50.00 |
| 9:36 | 54 | 50.00 | 9:48 | 53 | 50.00 | 10:24 | 50 | 50.00 |
| 9:37-9:48 | 53 | 47.50 | 9:49-10:12 | 51-52 | 47.50 | 10:25-10:36 | 49 | 47.50 |
| 9:49-10:12 | 51-52 | 45.00 | 10:13-10:24 | 50 | 45.00 | 10:37-10:54 | 48 | 45.00 |
| 10:13-10:36 | 49-50 | 43.50 | 10:25-10:54 | 48-49 | 43.50 | 10:55-11:24 | 46-47 | 43.50 |
| 10:37-11:06 | 47-48 | 42.00 | 10:55-11:24 | 46-47 | 42.00 | 11:25-11:54 | 44-45 | 42.00 |
| 11:07-11:36 | 45-46 | 40.50 | 11:25-11:54 | 44-45 | 40.50 | 11:55-12:30 | 42-43 | 40.50 |
| 11:37-12:12 | 43-44 | 39.00 | 11:55-12:30 | 42-43 | 39.00 | 12:31-13:12 | 40-41 | 39.00 |
| 12:13-12:54 | 41-42 | 37.50 | 12:31-12:54 | 41 | 37.50 | 13:13-13:36 | 39 | 37.50 |
| 12:55-13:36 | 39-40 | 36.00 | 12:55-13:36 | 39-40 | 36.00 | 13:37-14:24 | 37-38 | 36.00 |
| 13:37-14:24 | 37-38 | 34.00 | 13:37-14:24 | 37-38 | 34.00 | 14:25-15:18 | 35-36 | 34.00 |
| 14:25-14:54 | 36 | 32.00 | 14:25-14:54 | 36 | 32.00 | 15:19-15:48 | 34 | 32.00 |
| 14:55-15:18 | 35 | 30.00 | 14:55-15:18 | 35 | 30.00 | 15:49-16:24 | 33 | 30.00 |
| 15:19-15:48 | 34 | 27.00 | 15:19-15:48 | 34 | 27.00 | 16:25-16:54 | 32 | 27.00 |
| 15:49-16:24 | 33 | 24.00 | 15:49-16:24 | 33 | 24.00 | 16:55-17:36 | 31 | 24.00 |
| 16:25-16:54 | 32 | 21.00 | 16:25-16:54 | 32 | 21.00 | 17:37-18:12 | 30 | 21.00 |
| 16:55-17:36 | 31 | 18.00 | 16:55-17:36 | 31 | 18.00 | 18:13-18:54 | 29 | 18.00 |

| Males <25 and Males 25-29 | | | Males 30-34 and Males 35-39 | | | Males 40-44 and Males 45-49 | | |
|-------------------------------------|---|-------------------------|------------------------------------|---|-------------------------|------------------------------------|---|-------------------------|
| 1.5 Mile RunTime (min.) | VO2 (ml/kg/min) Submaximal Estimates | Component-Points | 1.5 Mile RunTime (min.) | VO2 (ml/kg/min) Submaximal Estimates | Component-Points | 1.5 Mile RunTime (min.) | VO2 (ml/kg/min) Submaximal Estimates | Component-Points |
| 17:37-18:12 | 30 | 15.00 | 17:37-18:12 | 30 | 15.00 | 18:55-19:42 | 28 | 15.00 |
| 18:13-18:54 | 29 | 12.00 | 18:13-18:54 | 29 | 12.00 | 19:43-20:36 | 27 | 12.00 |
| 18:55-19:42 | 28 | 9.00 | 18:55-19:42 | 28 | 9.00 | 20:37-21:30 | 26 | 9.00 |
| 19:43-20:36 | 27 | 6.00 | 19:43-20:36 | 27 | 6.00 | 21:31-22:30 | 25 | 6.00 |
| 20:37-21:30 | 26 | 3.00 | 20:37-21:30 | 26 | 3.00 | 22:31-23:36 | 24 | 3.00 |
| >21:30 | <26 | 0.00 | >21:30 | <26 | 0.00 | >23:36 | <24 | 0.00 |

| Males 50-54 and Males 55+ | | | Males 40-44 and Males 45-49 | | | Males 50-54 and Males 55+ | | |
|----------------------------------|---|-------------------------|------------------------------------|---|-------------------------|----------------------------------|---|-------------------------|
| 1.5 Mile RunTime (min.) | VO2 (ml/kg/min) Submaximal Estimates | Component-Points | 1.5 Mile RunTime (min.) | VO2 (ml/kg/min) Submaximal estimates | Component-Points | 1.5 Mile RunTime (min.) | VO2 (ml/kg/min) Submaximal Estimates | Component-Points |
| >11:06 | >47 | 50.00 | <10:24 | >50 | 50.00 | >11:06 | >47 | 50.00 |
| 11:06 | 47 | 50.00 | 10:24 | 50 | 50.00 | 11:06 | 47 | 50.00 |
| 11:07-11:24 | 46 | 47.50 | 10:25-10:36 | 49 | 47.50 | 11:07-11:24 | 46 | 47.50 |
| 11:25-11:36 | 45 | 45.00 | 10:37-10:54 | 48 | 45.00 | 11:25-11:36 | 45 | 45.00 |
| 11:37-12:12 | 43-44 | 43.50 | 10:55-11:24 | 46-47 | 43.50 | 11:37-12:12 | 43-44 | 43.50 |
| 12:13-12:54 | 41-42 | 42.00 | 11:25-11:54 | 44-45 | 42.00 | 12:13-12:54 | 41-42 | 42.00 |
| 12:55-13:36 | 39-40 | 40.50 | 11:55-12:30 | 42-43 | 40.50 | 12:55-13:36 | 39-40 | 40.50 |
| 13:37-14:24 | 37-38 | 39.00 | 12:31-13:12 | 40-41 | 39.00 | 13:37-14:24 | 37-38 | 39.00 |
| 14:25-15:18 | 35-36 | 37.50 | 13:13-13:36 | 39 | 37.50 | 14:25-15:18 | 35-36 | 37.50 |
| 15:19-15:48 | 34 | 36.00 | 13:37-14:24 | 37-38 | 36.00 | 15:19-15:48 | 34 | 36.00 |
| 15:49-16:54 | 32-33 | 34.00 | 14:25-15:18 | 35-36 | 34.00 | 15:49-16:54 | 32-33 | 34.00 |
| 16:55-17:36 | 31 | 32.00 | 15:19-15:48 | 34 | 32.00 | 16:55-17:36 | 31 | 32.00 |
| 17:37-18:12 | 30 | 30.00 | 15:49-16:24 | 33 | 30.00 | 17:37-18:12 | 30 | 30.00 |
| 18:13-18:54 | 29 | 27.00 | 16:25-16:54 | 32 | 27.00 | 18:13-18:54 | 29 | 27.00 |
| 18:55-19:42 | 28 | 24.00 | 16:55-17:36 | 31 | 24.00 | 18:55-19:42 | 28 | 24.00 |
| 19:43-20:36 | 27 | 21.00 | 17:37-18:12 | 30 | 21.00 | 19:43-20:36 | 27 | 21.00 |

| Males 50-54 and Males 55+ | | | Males 40-44 and Males 45-49 | | | Males 50-54 and Males 55+ | | |
|---------------------------|--------------------------------------|------------------|-----------------------------|--------------------------------------|------------------|---------------------------|--------------------------------------|------------------|
| 1.5 Mile RunTime (min.) | VO2 (ml/kg/min) Submaximal Estimates | Component-Points | 1.5 Mile RunTime (min.) | VO2 (ml/kg/min) Submaximal estimates | Component-Points | 1.5 Mile RunTime (min.) | VO2 (ml/kg/min) Submaximal Estimates | Component-Points |
| 20:37-21:30 | 26 | 18.00 | 18:13-18:54 | 29 | 18.00 | 20:37-21:30 | 26 | 18.00 |
| 21:31-22:30 | 25 | 15.00 | 18:55-19:42 | 28 | 15.00 | 21:31-22:30 | 25 | 15.00 |
| 22:31-23:36 | 24 | 12.00 | 19:43-20:36 | 27 | 12.00 | 22:31-23:36 | 24 | 12.00 |
| 23:37-24:48 | 23 | 9.00 | 20:37-21:30 | 26 | 9.00 | 23:37-24:48 | 23 | 9.00 |
| 24:49-26:06 | 22 | 6.00 | 21:31-22:30 | 25 | 6.00 | 24:49-26:06 | 22 | 6.00 |
| 26:07-27:36 | 21 | 3.00 | 22:31-23:36 | 24 | 3.00 | 26:07-27:36 | 21 | 3.00 |
| >27:36 | <21 | 0.00 | >23:36 | <24 | 0.00 | >27:36 | <21 | 0.00 |

Female

| Females <25 | | | Females 25-29 | | |
|--------------------------|--------------------------------------|------------------|--------------------------|--------------------------------------|------------------|
| 1.5 Mile Run-Time (min.) | VO2 (ml/kg/min) Submaximal Estimates | Component-Points | 1.5 Mile Run-Time (min.) | VO2 (ml/kg/min) Submaximal Estimates | Component-Points |
| <11:06 | >47 | 50.00 | <11:24 | >46 | 50.00 |
| 11:06 | 47 | 50.00 | 11:24 | 46 | 50.00 |
| 11:07-11:36 | 45-46 | 47.50 | 11:25-11:36 | 45 | 47.50 |
| 11:37-11:54 | 44 | 45.00 | 11:37-11:54 | 44 | 45.00 |
| 11:55-12:30 | 42-43 | 43.50 | 11:55-12:30 | 42-43 | 43.50 |
| 12:31-13:12 | 40-41 | 42.00 | 12:31-13:12 | 40-41 | 42.00 |
| 13:13-14:00 | 38-39 | 40.50 | 13:13-14:00 | 38-39 | 40.50 |
| 14:01-14:54 | 36-37 | 39.00 | 14:01-14:54 | 36-37 | 39.00 |
| 14:55-15:18 | 35 | 37.50 | 14:55-15:18 | 35 | 37.50 |
| 15:19-15:48 | 34 | 36.00 | 15:19-15:48 | 34 | 36.00 |
| 15:49-16:24 | 33 | 34.00 | 15:49-16:24 | 33 | 34.00 |
| 16:25-16:54 | 32 | 32.00 | 16:25-16:54 | 32 | 32.00 |
| 16:55-17:36 | 31 | 30.00 | 16:55-17:36 | 31 | 30.00 |
| 17:37-18:12 | 30 | 27.00 | 17:37-18:12 | 30 | 27.00 |
| 18:13-18:54 | 29 | 24.00 | 18:13-18:54 | 29 | 24.00 |

| Females <25 | | | Females 25-29 | | |
|--------------------------|--------------------------------------|------------------|--------------------------|--------------------------------------|------------------|
| 1.5 Mile Run-Time (min.) | VO2 (ml/kg/min) Submaximal Estimates | Component-Points | 1.5 Mile Run-Time (min.) | VO2 (ml/kg/min) Submaximal Estimates | Component-Points |
| 18:55-19:42 | 28 | 21.00 | 18:55-19:42 | 28 | 21.00 |
| 19:43-20:36 | 27 | 18.00 | 19:43-20:36 | 27 | 18.00 |
| 20:37-21:30 | 26 | 15.00 | 20:37-21:30 | 26 | 15.00 |
| 21:31-22:30 | 25 | 12.00 | 21:31-22:30 | 25 | 12.00 |
| 22:31-23:36 | 24 | 9.00 | 22:31-23:36 | 24 | 9.00 |
| 23:37-24:48 | 23 | 6.00 | 23:37-24:48 | 23 | 6.00 |
| 24:49-26:06 | 22 | 3.00 | 24:49-26:06 | 22 | 3.00 |
| >26:06 | <22 | 0.00 | >26:06 | <22 | 0.00 |

| Females 30-34 and Females 35-39 | | | Females 40-44 and Females 45-49 | | | Females 50-54 and Females 55+ | | |
|---------------------------------|--------------------------------------|------------------|---------------------------------|--------------------------------------|------------------|-------------------------------|--------------------------------------|------------------|
| 1.5 Mile RunTime (min.) | VO2 (ml/kg/min) Submaximal Estimates | Component-Points | 1.5 Mile RunTime (min.) | VO2 (ml/kg/min) Submaximal Estimates | Component-Points | 1.5 Mile RunTime (min.) | VO2 (ml/kg/min) Submaximal Estimates | Component-Points |
| <11:54 | >44 | 50.00 | <12:30 | >42 | 50.00 | <14:24 | >37 | 50.00 |
| 11:54 | 44 | 50.00 | 12:30 | 42 | 50.00 | 14:24 | 37 | 50.00 |
| 11:55-12:30 | 42-43 | 47.50 | 12:31-12:54 | 41 | 47.50 | 14:25-14:54 | 36 | 47.50 |
| 12:31-12:54 | 41 | 45.00 | 12:55-13:12 | 40 | 45.00 | 14:55-15:18 | 35 | 45.00 |
| 12:55-13:12 | 40 | 43.50 | 13:13-14:00 | 38-39 | 43.50 | 15:19-16:24 | 33-34 | 43.50 |
| 13:13-13:36 | 39 | 42.00 | 14:01-14:54 | 36-37 | 42.00 | 16:25-16:54 | 32 | 42.00 |
| 13:37-14:24 | 37-38 | 40.50 | 14:55-15:48 | 34-35 | 40.50 | 16:55-17:36 | 31 | 40.50 |
| 14:25-14:54 | 36 | 39.00 | 15:49-16:24 | 33 | 39.00 | 17:37-18:12 | 30 | 39.00 |
| 14:55-15:18 | 35 | 37.50 | 16:25-16:54 | 32 | 37.50 | 18:13-18:54 | 29 | 37.50 |
| 15:19-15:48 | 34 | 36.00 | 16:55-17:36 | 31 | 36.00 | 18:55-19:42 | 28 | 36.00 |
| 15:49-16:24 | 33 | 34.00 | 17:37-18:12 | 30 | 34.00 | 19:43-20:36 | 27 | 34.00 |
| 16:25-16:54 | 32 | 32.00 | 18:13-18:54 | 29 | 32.00 | 20:37-21:30 | 26 | 32.00 |
| 16:55-17:36 | 31 | 30.00 | 18:55-19:42 | 28 | 30.00 | 21:31-22:30 | 25 | 30.00 |
| 17:37-18:12 | 30 | 27.00 | 19:43-20:36 | 27 | 27.00 | 22:31-23:36 | 24 | 27.00 |

| Females 30-34 and Females 35-39 | | | Females 40-44 and Females 45-49 | | | Females 50-54 and Females 55+ | | |
|---------------------------------|--------------------------------------|------------------|---------------------------------|--------------------------------------|------------------|-------------------------------|--------------------------------------|------------------|
| 1.5 Mile RunTime (min.) | VO2 (ml/kg/min) Submaximal Estimates | Component-Points | 1.5 Mile RunTime (min.) | VO2 (ml/kg/min) Submaximal Estimates | Component-Points | 1.5 Mile RunTime (min.) | VO2 (ml/kg/min) Submaximal Estimates | Component-Points |
| 18:13-18:54 | 29 | 24.00 | 20:37-21:30 | 26 | 24.00 | 23:37-24:48 | 23 | 24.00 |
| 18:55-19:42 | 28 | 21.00 | 21:31-22:30 | 25 | 21.00 | 24:49-26:06 | 22 | 21.00 |
| 19:43-20:36 | 27 | 18.00 | 22:31-23:36 | 24 | 18.00 | 26:07-27:36 | 21 | 18.00 |
| 20:37-21:30 | 26 | 15.00 | 23:37-24:48 | 23 | 15.00 | 27:37-29:18 | 20 | 15.00 |
| 21:31-22:30 | 25 | 12.00 | 24:49-26:06 | 22 | 12.00 | 29:19-31:12 | 19 | 12.00 |
| 22:31-23:36 | 24 | 9.00 | 26:07-27:36 | 21 | 9.00 | 31:13-33:18 | 18 | 9.00 |
| 23:37-24:48 | 23 | 6.00 | 27:37-29:18 | 20 | 6.00 | 33:19-35:48 | 17 | 6.00 |
| 24:49-26:06 | 22 | 3.00 | 29:19-31:12 | 19 | 3.00 | 35:49-38:36 | 16 | 3.00 |
| >26:06 | <22 | 0.00 | >31:12 | <19 | 0.00 | >38:36 | <16 | 0.00 |

Navy < 5K

Workout Overview

This workout was designed by the Navy to test, evaluate, and measure fitness levels. The goal is to complete the set distance of 1.5 miles (2.4 km) in the least amount of time. The user controls the speed as needed to reach the goal. A point value will be given at the completion of the test.

Use this workout when performing the test at altitudes below 5,000 feet (1,524 meters).

Input information:

- Age
- Weight
- Gender
- Starting Speed

Male

| | | | 17-19 | 20-24 | 25-29 | 30-34 |
|--------------|--------|------------------|--------------------------|--------------------------|--------------------------|--------------------------|
| Category | Level | Component-Points | 1.5 Mile Run-Time (min.) | 1.5 Mile Run-Time (min.) | 1.5 Mile Run-Time (min.) | 1.5 Mile Run-Time (min.) |
| Outstanding | High | 100 | 8:15 | 8:30 | 8:55 | 9:20 |
| Outstanding | Medium | 95 | 8:45 | 9:00 | 9:23 | 9:45 |
| Outstanding | Low | 90 | 9:00 | 9:15 | 9:38 | 10:00 |
| Excellent | High | 85 | 9:15 | 9:45 | 10:15 | 10:30 |
| Excellent | Medium | 80 | 9:30 | 10:00 | 10:30 | 11:00 |
| Excellent | Low | 75 | 9:45 | 10:30 | 10:52 | 11:15 |
| Good | High | 70 | 10:00 | 10:45 | 11:23 | 12:00 |
| Good | Medium | 65 | 10:30 | 11:30 | 12:15 | 13:00 |
| Good | Low | 60 | 11:00 | 12:00 | 12:53 | 13:45 |
| Satisfactory | High | 55 | 12:00 | 12:45 | 13:23 | 14:00 |
| Satisfactory | Medium | 50 | 12:15 | 13:15 | 13:45 | 14:15 |
| Probationary | | 45 | 12:30 | 13:30 | 14:00 | 14:30 |

| 35-39 | 40-44 | 45-49 | 50-54 | 55-59 | 60-64 | 65+ |
|--------------------------|--------------------------|--------------------------|--------------------------|--------------------------|--------------------------|--------------------------|
| 1.5 Mile Run-Time (min.) | 1.5 Mile Run-Time (min.) | 1.5 Mile Run-Time (min.) | 1.5 Mile Run-Time (min.) | 1.5 Mile Run-Time (min.) | 1.5 Mile Run-Time (min.) | 1.5 Mile Run-Time (min.) |
| 9:25 | 9:30 | 9:33 | 9:35 | 10:42 | 11:21 | 11:41 |
| 9:53 | 10:00 | 10:08 | 10:15 | 11:09 | 11:48 | 12:13 |

| 35-39 | 40-44 | 45-49 | 50-54 | 55-59 | 60-64 | 65+ |
|---------------------------------|---------------------------------|---------------------------------|---------------------------------|---------------------------------|---------------------------------|---------------------------------|
| 1.5 Mile Run-Time (min.) | 1.5 Mile Run-Time (min.) | 1.5 Mile Run-Time (min.) | 1.5 Mile Run-Time (min.) | 1.5 Mile Run-Time (min.) | 1.5 Mile Run-Time (min.) | 1.5 Mile Run-Time (min.) |
| 10:08 | 10:15 | 10:30 | 10:45 | 11:25 | 12:04 | 12:43 |
| 10:38 | 10:45 | 11:08 | 11:30 | 11:57 | 12:40 | 13:20 |
| 11:08 | 11:15 | 11:38 | 12:00 | 12:29 | 13:16 | 13:57 |
| 11:23 | 11:45 | 12:08 | 12:30 | 13:12 | 13:53 | 14:34 |
| 12:23 | 12:45 | 13:00 | 13:15 | 14:13 | 15:00 | 15:47 |
| 13:23 | 13:45 | 14:08 | 14:30 | 15:14 | 16:07 | 17:00 |
| 14:08 | 14:30 | 14:53 | 15:15 | 16:15 | 17:14 | 18:13 |
| 14:23 | 14:45 | 15:15 | 15:45 | 16:33 | 17:47 | 19:00 |
| 14:45 | 15:15 | 15:45 | 16:15 | 16:51 | 18:20 | 19:47 |
| 15:00 | 15:30 | 16:08 | 16:45 | 17:09 | 18:52 | 20:35 |

Female

| | | | 17-19 | 20-24 | 25-29 | 30-34 |
|-----------------|--------------|-------------------------|---------------------------------|---------------------------------|---------------------------------|---------------------------------|
| Category | Level | Component-Points | 1.5 Mile Run-Time (min.) | 1.5 Mile Run-Time (min.) | 1.5 Mile Run-Time (min.) | 1.5 Mile Run-Time (min.) |
| Outstanding | High | 100 | 9:29 | 9:47 | 10:17 | 10:46 |
| Outstanding | Medium | 95 | 11:15 | 11:15 | 11:30 | 11:45 |
| Outstanding | Low | 90 | 11:30 | 11:30 | 11:45 | 12:00 |
| Excellent | High | 85 | 11:45 | 12:15 | 12:30 | 12:45 |
| Excellent | Medium | 80 | 12:00 | 12:45 | 13:00 | 13:15 |
| Excellent | Low | 75 | 12:30 | 13:15 | 13:23 | 13:30 |
| Good | High | 70 | 12:45 | 13:30 | 14:00 | 14:30 |
| Good | Medium | 65 | 13:00 | 13:45 | 14:30 | 15:15 |
| Good | Low | 60 | 13:30 | 14:15 | 14:53 | 15:30 |
| Satisfactory | High | 55 | 14:15 | 15:00 | 15:23 | 15:45 |
| Satisfactory | Medium | 50 | 14:45 | 15:15 | 15:45 | 16:15 |
| Probationary | 45 | 15:00 | 15:30 | 16:08 | 16:45 | |

| 35-39 | 40-44 | 45-49 | 50-54 | 55-59 | 60-64 | 65+ |
|---------------------------------|---------------------------------|---------------------------------|---------------------------------|---------------------------------|---------------------------------|---------------------------------|
| 1.5 Mile Run-Time (min.) | 1.5 Mile Run-Time (min.) | 1.5 Mile Run-Time (min.) | 1.5 Mile Run-Time (min.) | 1.5 Mile Run-Time (min.) | 1.5 Mile Run-Time (min.) | 1.5 Mile Run-Time (min.) |
| 10:51 | 10:56 | 10:58 | 11:00 | 12:23 | 13:34 | 14:45 |
| 11:53 | 12:00 | 12:08 | 12:15 | 13:39 | 14:50 | 16:01 |
| 12:08 | 12:15 | 12:30 | 12:45 | 13:57 | 15:08 | 16:19 |
| 12:53 | 13:00 | 13:15 | 13:30 | 14:25 | 15:34 | 16:43 |
| 13:23 | 13:30 | 13:45 | 14:00 | 14:53 | 16:00 | 17:07 |
| 13:45 | 14:00 | 14:08 | 14:15 | 15:20 | 16:25 | 17:30 |
| 14:38 | 14:45 | 15:00 | 15:15 | 16:09 | 17:17 | 18:18 |
| 15:30 | 15:45 | 15:53 | 16:00 | 16:58 | 18:06 | 19:06 |
| 15:53 | 16:15 | 16:30 | 16:45 | 17:48 | 18:51 | 19:54 |
| 16:15 | 16:45 | 16:53 | 17:00 | 18:03 | 19:08 | 20:13 |
| 16:38 | 17:00 | 17:08 | 17:15 | 18:18 | 19:25 | 20:31 |
| 17:00 | 17:15 | 17:23 | 17:30 | 18:34 | 19:43 | 20:52 |

Navy > 5K

Workout Overview

This workout was designed by the Navy to test, evaluate, and measure fitness levels. The goal is to complete the set distance of 1.5 miles (2.4 km) in the least amount of time. The user controls the speed as needed to reach the goal. A point value will be given at the completion of the test.

Use this workout when performing the test at altitudes above 5,000 feet (1,524 meters).

Input information:

- Age
- Weight
- Gender
- Starting Speed

Male

| | | | 17-19 | 20-24 | 25-29 | 30-34 |
|--------------|--------|------------------|--------------------------|--------------------------|--------------------------|--------------------------|
| Category | Level | Component-Points | 1.5 Mile Run-Time (min.) | 1.5 Mile Run-Time (min.) | 1.5 Mile Run-Time (min.) | 1.5 Mile Run-Time (min.) |
| Outstanding | High | 100 | 9:00 | 9:15 | 9:43 | 10:10 |
| Outstanding | Medium | 95 | 9:30 | 9:50 | 10:15 | 10:40 |
| Outstanding | Low | 90 | 9:50 | 10:05 | 10:30 | 10:55 |
| Excellent | High | 85 | 10:05 | 10:40 | 11:13 | 11:45 |
| Excellent | Medium | 80 | 10:20 | 10:55 | 11:28 | 12:00 |
| Excellent | Low | 75 | 10:40 | 11:25 | 11:50 | 12:15 |
| Good | High | 70 | 10:55 | 11:45 | 12:25 | 13:05 |
| Good | Medium | 65 | 11:25 | 12:30 | 13:20 | 14:10 |
| Good | Low | 60 | 12:00 | 13:05 | 14:03 | 15:00 |
| Satisfactory | High | 55 | 13:05 | 13:55 | 14:35 | 15:15 |
| Satisfactory | Medium | 50 | 13:20 | 14:25 | 14:58 | 15:30 |
| Probationary | | 45 | 13:40 | 14:45 | 15:18 | 15:50 |

| 35-39 | 40-44 | 45-49 | 50-54 | 55-59 | 60-64 | 65+ |
|--------------------------|--------------------------|--------------------------|--------------------------|--------------------------|--------------------------|--------------------------|
| 1.5 Mile Run-Time (min.) | 1.5 Mile Run-Time (min.) | 1.5 Mile Run-Time (min.) | 1.5 Mile Run-Time (min.) | 1.5 Mile Run-Time (min.) | 1.5 Mile Run-Time (min.) | 1.5 Mile Run-Time (min.) |
| 10:15 | 10:20 | 10:23 | 10:25 | 11:46 | 12:29 | 12:51 |
| 10:48 | 10:55 | 11:03 | 11:10 | 12:16 | 12:59 | 13:26 |

| 35-39 | 40-44 | 45-49 | 50-54 | 55-59 | 60-64 | 65+ |
|---------------------------------|---------------------------------|---------------------------------|---------------------------------|---------------------------------|---------------------------------|---------------------------------|
| 1.5 Mile Run-Time (min.) | 1.5 Mile Run-Time (min.) | 1.5 Mile Run-Time (min.) | 1.5 Mile Run-Time (min.) | 1.5 Mile Run-Time (min.) | 1.5 Mile Run-Time (min.) | 1.5 Mile Run-Time (min.) |
| 11:03 | 11:10 | 11:28 | 11:45 | 12:34 | 13:16 | 13:59 |
| 11:45 | 11:45 | 12:08 | 12:30 | 13:09 | 13:56 | 14:40 |
| 12:08 | 12:15 | 12:40 | 13:05 | 13:44 | 14:36 | 15:21 |
| 12:33 | 12:50 | 13:15 | 13:40 | 14:31 | 15:16 | 16:01 |
| 13:30 | 13:55 | 14:10 | 14:25 | 15:38 | 16:30 | 17:22 |
| 14:35 | 15:00 | 15:25 | 15:50 | 16:45 | 17:44 | 18:42 |
| 15:25 | 15:50 | 16:15 | 16:40 | 17:53 | 18:57 | 20:02 |
| 15:40 | 16:05 | 16:38 | 17:10 | 18:12 | 19:34 | 20:54 |
| 16:05 | 16:40 | 17:13 | 17:45 | 18:32 | 20:10 | 21:46 |
| 16:23 | 16:55 | 17:35 | 18:15 | 18:52 | 20:45 | 22:39 |

Female

| | | | 17-19 | 20-24 | 25-29 | 30-34 |
|-----------------|--------------|-------------------------|---------------------------------|---------------------------------|---------------------------------|---------------------------------|
| Category | Level | Component-Points | 1.5 Mile Run-Time (min.) | 1.5 Mile Run-Time (min.) | 1.5 Mile Run-Time (min.) | 1.5 Mile Run-Time (min.) |
| Outstanding | High | 100 | 10:20 | 10:40 | 11:13 | 11:45 |
| Outstanding | Medium | 95 | 12:15 | 12:15 | 12:33 | 12:50 |
| Outstanding | Low | 90 | 12:30 | 12:30 | 12:48 | 13:05 |
| Excellent | High | 85 | 12:50 | 13:20 | 13:38 | 13:55 |
| Excellent | Medium | 80 | 13:05 | 13:55 | 14:10 | 14:25 |
| Excellent | Low | 75 | 13:40 | 14:25 | 14:35 | 14:45 |
| Good | High | 70 | 13:55 | 14:45 | 15:18 | 15:50 |
| Good | Medium | 65 | 14:10 | 15:00 | 15:50 | 16:40 |
| Good | Low | 60 | 14:45 | 15:30 | 16:13 | 16:55 |
| Satisfactory | High | 55 | 15:30 | 16:20 | 16:45 | 17:10 |
| Satisfactory | Medium | 50 | 16:05 | 16:40 | 17:13 | 17:45 |
| Probationary | | 45 | 16:20 | 16:55 | 17:35 | 18:15 |

| 35-39 | 40-44 | 45-49 | 50-54 | 55-59 | 60-64 | 65+ |
|---------------------------------|---------------------------------|---------------------------------|---------------------------------|---------------------------------|---------------------------------|---------------------------------|
| 1.5 Mile Run Time (min.) | 1.5 Mile Run Time (min.) | 1.5 Mile Run Time (min.) | 1.5 Mile Run Time (min.) | 1.5 Mile Run Time (min.) | 1.5 Mile Run Time (min.) | 1.5 Mile Run Time (min.) |
| 11:50 | 11:55 | 11:58 | 12:00 | 13:37 | 14:55 | 16:14 |
| 12:58 | 13:05 | 13:13 | 13:20 | 15:01 | 16:19 | 17:37 |
| 13:13 | 13:20 | 13:38 | 13:55 | 15:21 | 16:39 | 17:57 |
| 14:03 | 14:10 | 14:28 | 14:45 | 15:52 | 17:07 | 18:23 |
| 14:35 | 14:45 | 15:00 | 15:15 | 16:22 | 17:36 | 18:50 |
| 15:00 | 15:15 | 15:23 | 15:30 | 16:52 | 18:04 | 19:15 |
| 15:58 | 16:05 | 16:23 | 16:40 | 17:46 | 19:01 | 20:08 |
| 16:55 | 17:10 | 17:18 | 17:25 | 18:40 | 19:55 | 21:01 |
| 17:20 | 17:45 | 18:00 | 18:15 | 19:35 | 20:44 | 21:53 |
| 17:43 | 18:15 | 18:23 | 18:30 | 19:51 | 21:03 | 22:14 |
| 18:08 | 18:30 | 18:40 | 18:50 | 20:08 | 21:22 | 22:34 |
| 18:33 | 18:50 | 18:58 | 19:05 | 20:25 | 21:41 | 22:57 |

Marines Sea Level

Workout Overview

This workout was designed by the Marines to test, evaluate, and measure fitness levels. The goal is to complete the set distance of 3.0 miles (4.8 km) in the least amount of time. The user controls the speed as needed to reach the goal. A point value will be given at the completion of the test.

Use this workout when performing the test at altitudes below 4,500 feet (1,372 meters).

Input information:

- Age
- Weight
- Gender
- Starting Speed

| Points | Male | Female |
|---------------|-------------------------------|-------------------------------|
| | 3 mile run no altitude | 3 mile run no altitude |
| 100 | 18:00 | 21:00 |
| 90 | 19:40 | 22:40 |
| 80 | 21:20 | 24:20 |
| 70 | 23:00 | 26:00 |
| 60 | 24:40 | 27:40 |
| 50 | 26:20 | 29:20 |
| 40 | 28:00 | 31:00 |
| 30 | 29:40 | 32:40 |
| 20 | 31:20 | 34:20 |
| 10 | 33:00 | 36:00 |

Required minimum score

| Age | Unsatisfactory | 3rd Class | 2nd Class | 1st Class |
|------------|-----------------------|------------------|------------------|------------------|
| 17-26 | 0-134 | 135 | 175 | 225 |
| 27-39 | 0-109 | 110 | 150 | 200 |
| 40-45 | 0-87 | 88 | 125 | 175 |
| 46+ | 0-64 | 65 | 100 | 150 |

Marines > 4.5K

Workout Overview

This workout was designed by the Marines to test, evaluate, and measure fitness levels. The goal is to complete the set distance of 3.0 miles (4.8 km) in the least amount of time. The user controls the speed as needed to reach the goal. A point value will be given at the completion of the test.

Use this workout when performing the test at altitudes above 4,500 feet (1,372 meters).

Input information:

- Age
- Weight
- Gender
- Starting Speed

| Points | Male | Female |
|---------------|--|--|
| | 3 mile run 4,500 feet above sea level | 3 mile run 4,500 feet above sea level |
| 100 | 19:30 | 22:30 |
| 90 | 21:10 | 24:10 |
| 80 | 22:50 | 25:50 |
| 70 | 24:30 | 27:30 |
| 60 | 26:10 | 29:10 |
| 50 | 27:50 | 30:50 |
| 40 | 29:30 | 32:30 |
| 30 | 31:10 | 34:10 |
| 20 | 32:50 | 35:50 |
| 10 | 34:30 | 37:30 |
| 1 | 36:00 | 39:00 |

Required minimum score

| Age | Unsatisfactory | 3rd Class | 2nd Class | 1st Class |
|------------|-----------------------|------------------|------------------|------------------|
| 17-26 | 0-134 | 135 | 175 | 225 |
| 27-39 | 0-109 | 110 | 150 | 200 |
| 40-45 | 0-87 | 88 | 125 | 175 |
| 46+ | 0-64 | 65 | 100 | 150 |

One Mile Test

Workout Overview

The objective of this test is to monitor the development of the athlete's VO₂ max.

 **Note:** This workout requires the user to wear a 5 KHz Polar® or compatible heart rate transmitter belt.

Input information:

- Age
- Weight
- Gender
- Starting Speed
- Heart rate

Heart Rate Requirements:

Wireless heart rate transmitter

Test procedure:

1. Record your weight
2. Walk one mile (1,609 metres) as fast as possible
3. Record the time to complete the one mile walk
4. Immediately on finishing the walk record your heart rate (beats per minute)
5. Determine your VO₂ max

The formula used to calculate VO₂ max is:

$132.853 - (0.0769 * \text{Weight}) - (0.3877 * \text{Age}) + (6.315 * \text{Gender}) - (3.2649 * \text{Time}) - (0.1565 * \text{Heart rate})$

Input values are:

- Weight is in pounds (lbs)
- Age is in years
- Gender Male = 1 and Female = 0
- Time is expressed in minutes and 100ths of minutes
- Heart rate is in beats/min

Analysis of VO₂ max scores

Male (values in ml/kg/min)

| Age | Very Poor | Poor | Fair | Good | Excellent | Superior |
|-------|-----------|-------------|-------------|-------------|-------------|----------|
| 13-19 | <35.0 | 35.0 - 38.3 | 38.4 - 45.1 | 45.2 - 50.9 | 51.0 - 55.9 | >55.9 |
| 20-29 | <33.0 | 33.0 - 36.4 | 36.5 - 42.4 | 42.5 - 46.4 | 46.5 - 52.4 | >52.4 |
| 30-39 | <31.5 | 31.5 - 35.4 | 35.5 - 40.9 | 41.0 - 44.9 | 45.0 - 49.4 | >49.4 |

| Age | Very Poor | Poor | Fair | Good | Excellent | Superior |
|------------|------------------|-------------|-------------|-------------|------------------|-----------------|
| 40-49 | <30.2 | 30.2 - 33.5 | 33.6 - 38.9 | 39.0 - 43.7 | 43.8 - 48.0 | >48.0 |
| 50-59 | <26.1 | 26.1 - 30.9 | 31.0 - 35.7 | 35.8 - 40.9 | 41.0 - 45.3 | >45.3 |
| 60+ | <20.5 | 20.5 - 26.0 | 26.1 - 32.2 | 32.3 - 36.4 | 36.5 - 44.2 | >44.2 |

Female (values in ml/kg/min)

| Age | Very Poor | Poor | Fair | Good | Excellent | Superior |
|------------|------------------|-------------|-------------|-------------|------------------|-----------------|
| 13-19 | <25.0 | 25.0 - 30.9 | 31.0 - 34.9 | 35.0 - 38.9 | 39.0 - 41.9 | >41.9 |
| 20-29 | <23.6 | 23.6 - 28.9 | 29.0 - 32.9 | 33.0 - 36.9 | 37.0 - 41.0 | >41.0 |
| 30-39 | <22.8 | 22.8 - 26.9 | 27.0 - 31.4 | 31.5 - 35.6 | 35.7 - 40.0 | >40.0 |
| 40-49 | <21.0 | 21.0 - 24.4 | 24.5 - 28.9 | 29.0 - 32.8 | 32.9 - 36.9 | >36.9 |
| 50-59 | <20.2 | 20.2 - 22.7 | 22.8 - 26.9 | 27.0 - 31.4 | 31.5 - 35.7 | >35.7 |
| 60+ | <17.5 | 17.5 - 20.1 | 20.2 - 24.4 | 24.5 - 30.2 | 30.3 - 31.4 | >31.4 |



10 Trotter Drive, Medway, MA 02053 • 888-462-9239 • 508-533-4300 • FAX 508-533-5183

www.cybexintl.com