



Cybex LCX-425T Treadmill
Owner's Manual
Cardiovascular Systems
Part Number LT-19341-4 F



Cybex LCX-425T Treadmill
Owner's Manual
Cardiovascular Systems
Part Number LT-19341-4 F

Cybex® and the Cybex logo are registered trademarks of Cybex International, Inc. Polar® is a registered trademark of Polar Electro Inc.

DISCLAIMER: Cybex International, Inc. makes no representations or warranties regarding the contents of this manual. We reserve the right to revise this document at any time or to make changes to the product described within it without notice or obligation to notify any person of such revisions or changes.

© 2010, Cybex International, Inc. All rights reserved. Printed in United States of America.

10 Trotter Drive Medway, MA 02053 • 888-462-9239 • 508-533-4300 • FAX 508-533-5183
www.cybexinternational.com • techhelp@cybexintl.com • LT-19341-4 F • January 2010

Table of Contents

| | |
|--|------|
| Front Pages | |
| About this Manual | iii |
| FCC Compliance Information | iii |
| 1 Safety | |
| Important Voltage Information | 1-1 |
| Grounding Instructions | 1-1 |
| Important Safety Instructions | 1-2 |
| Warning Decals | 1-4 |
| Caution Decals | 1-7 |
| Emergency Stop Key (e-stop) | 1-7 |
| 2 Assembly and Setup | |
| Warnings/Cautions | 2-1 |
| Choosing and Preparing a Site | 2-1 |
| Electrical Power Requirements | 2-2 |
| Assembling the Treadmill | 2-2 |
| Testing the Treadmill Operation | 2-10 |
| Setting Operation Options | 2-11 |
| 3 Operation | |
| Terms and Symbols Used | 3-1 |
| Quick Operation Guide | 3-2 |
| Detailed Operation Guide | 3-2 |
| Stopping the Treadmill | 3-4 |
| Immobilization Method | 3-5 |
| Emergency Dismount | 3-5 |
| Emergency Stop | 3-5 |
| Control During Operation | 3-5 |
| Data Readouts | 3-6 |
| Displaying Heart Rate | 3-7 |
| Heart Rate Zone | 3-8 |
| Meaning of % Grade | 3-8 |
| Use of Programs | 3-9 |
| Audio/Video | 3-10 |
| 4 Preventive Maintenance | |
| Warnings/Cautions | 4-1 |
| Regular Maintenance Activities | 4-1 |
| Cleaning Your Treadmill | 4-1 |
| Running Belt Maintenance | 4-3 |
| Other Preventive Maintenance | 4-5 |
| Service Schedule | 4-6 |
| 5 Customer Service | |
| Contacting Service | 5-1 |
| Serial Number and Voltage | 5-1 |
| Return Material Authorization (RMA) | 5-2 |
| Damaged Parts | 5-2 |
| Ordering Parts | 5-3 |
| Appendix A - Technical Specifications | A-1 |
| Appendix B - Program Overview | B-1 |
| Appendix C - Parts List | C-1 |
| Appendix D - Exploded View | D-1 |
| Appendix E - Schematic | E-1 |

Cybex 425T Treadmill Owner's Manual

About This Manual

An Owner's Manual is shipped with each unit. To purchase additional copies of this manual or any other Cybex manual, please do one of the following:

- fax your order to 508-533-5183
- contact Cybex Customer Service at 888-462-9239
- or contact Cybex Customer Service at 508-533-4300

To contact Cybex with comments about this manual you may send email to techhelp@cybexintl.com.

FCC Compliance Information



WARNING: Changes or modifications to this unit not expressly approved by the party responsible for compliance could void the user's authority to operate the equipment.

This equipment has been tested and found to comply with the limits for a Class B digital device, pursuant to Part 15 of the FCC Rules. These limits are designed to provide reasonable protection against harmful interference in a residential installation. This equipment generates, uses and can radiate radio frequency energy and, if not installed and used in accordance with the instructions, may cause harmful interference to radio communications. However, there is no guarantee that interference will not occur in a particular installation. If this equipment does cause harmful interference to radio or television reception (which can be determined by turning the equipment off and on) the user is encouraged to try to correct the interference by one or more of the following measures:

- Reorient or relocate the receiving antenna.
- Increase the separation between the equipment and receiver.
- Connect the equipment into an outlet on a circuit different from that to which the receiver is connected.
- Consult the dealer or an experienced radio TV technician for help.

1 - Safety

IMPORTANT: Read all instructions and warnings before using the treadmill.

Important Voltage Information

Before plugging the power cord into an electrical outlet, verify that the voltage requirements for your area match the voltage of the treadmill that you have received. The power requirements for the Cybox 425T treadmill include a grounded, dedicated circuit, rated for one of the following: 115 VAC \pm 5%, 60 Hz and 15 amps; 208/220 VAC, 60 Hz and 10 amps or 230 VAC \pm 5%, 50 Hz and 10 amps. See the serial number decal for the exact voltage requirements of your treadmill.



WARNING: Do not attempt to use this unit with a voltage adapter. Do not attempt to use this unit with an extension cord.



WARNING: Do not plug more than one unit into a single circuit.

Grounding Instructions

This treadmill must be grounded. If it should malfunction or break down, grounding provides a path of least resistance for electric current to reduce the risk of electric shock. This product is equipped with a cord having an equipment-grounding conductor and a grounding plug. The plug must be plugged into an appropriate outlet that is properly installed and grounded in accordance with all local codes and ordinances.



DANGER:
Improper connection of the equipment-grounding conductor can result in a risk of electric shock. Check with a qualified electrician or service provider if you are in doubt as to whether the treadmill is properly grounded. Seek a qualified electrician to perform any modifications to the cord or plug. Cybox is not responsible for injuries or damages as a result of cord or plug modification.

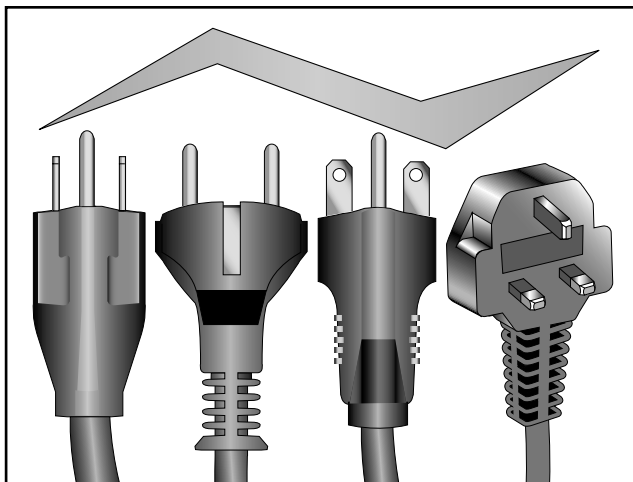

115V
NEMA 5-15

Euro Plug
CEE 7/7

208/220V
NEMA 6-15

UK
230VAC

This treadmill is for use on a nominal 115 VAC \pm 5%, 60 Hz and 15 amps, 208/220 VAC; 60 Hz, 10 amps or 230 VAC \pm 5%, 50 Hz and 10 amps and a grounded, dedicated circuit. Make sure that the treadmill is connected to an outlet having the same configuration as the plug. Do not use a ground plug adapter to adapt the power cord to a

Important Safety Instructions

(Save These Instructions)



DANGER: *To reduce the risk of electric shock, always unplug this treadmill from the electrical outlet immediately after using it and before cleaning it.*



WARNING: *Serious injury could occur if these precautions are not observed. To reduce the risk of burns, fires, electric shock, or injury:*

User Safety Precautions



- **DO NOT** wear loose or dangling clothing while using.

WARNING: *Heart rate monitoring systems may be inaccurate. Over exercise may result in serious injury or death. If you feel faint stop exercising immediately.*

- Use the treadmill handrails for support and to maintain balance.
- Stop exercising if you feel faint, dizzy, or experience pain at any time and consult your physician.
- Obtain a medical exam before beginning any exercise program.
- Read and understand emergency stop procedures.
- Replace any warning labels if damaged, worn or illegible.
- Report any malfunctions, damage or repairs to the facility.
- Place your feet on the two top steps when starting or stopping the treadmill.
- Stop and place the treadmill at 0 degrees incline (level) after each use.
- Keep children away from the treadmill. Teenagers and disabled persons must be supervised.
- Obtain instruction before using.
- Keep all body parts, towels, and the like free and clear of moving parts.
- Read and understand the Owner's Manual and all warnings posted on the unit before using. 
- **DO NOT** use the unit if you exceed 350 lbs. (158 kg). This is the rated maximum user weight.
- Disconnect power before servicing.

Facility Safety Precautions

- Instruct all users on how to clip the e-stop clip onto their clothing and carefully test it prior to using the treadmill.
- Instruct all users to use caution when mounting and dismounting the treadmill.
- Use a dedicated line when operating the treadmill. **NOTE: A dedicated line requires one circuit breaker per unit.**
- Connect the treadmill to a properly grounded outlet only.

Cybox 425T Treadmill Owner's Manual

- **DO NOT** operate electrically powered treadmills in damp or wet locations.
- Keep the running belt clean and dry at all times.
- **DO NOT** leave the treadmill unattended when plugged in and running. **NOTE: Before leaving the treadmill unattended, always wait until the treadmill comes to a complete stop and is level. Then remove the plug from the outlet. Remove the e-stop key from the treadmill.**
- Immobilize the treadmill (when not in use) by removing the e-stop key.
- Inspect the treadmill for worn or loose components before each use. Do not use until worn or damaged parts are replaced.
- Maintain and replace worn parts regularly. Refer to "Preventive Maintenance" section of Owner's Manual.
- **DO NOT** operate the treadmill if: (1) the cord is damaged; (2) the treadmill is not working properly or (3) if the treadmill has been dropped or damaged. Seek service from a qualified technician.
- **DO NOT** place the cord near heated surfaces or sharp edges.
- **DO NOT** use the treadmill outdoors.
- **DO NOT** operate the treadmill around or where aerosol (spray) or where oxygen products are being used.
- Read and understand the Owner's Manual completely before using the treadmill.
- Ensure all users wear proper footwear on or around all Cybex equipment.
- Set up and operate the treadmill on a solid, level surface. Do not operate in recessed areas or on plush carpet.
- Provide the following clearances: 19.7 inches (0.5 m) at each side, 79 inches (2.0 m) at the back and enough room for safe access and passage at the front of the treadmill. Be sure your treadmill is clear of walls, equipment and other hard surfaces.
- **DO NOT** attempt repairs, electrical or mechanical. Seek qualified repair personnel when servicing. If you live in the USA, contact Cybex Customer Service at 888-462-9239. If you live outside the USA, contact Cybex Customer Service at 508-533-4300.
- Use Cybex factory parts when replacing parts on the treadmill.
- **DO NOT** modify the treadmill in any way.
- **DO NOT** use attachments unless recommended for the treadmill by Cybex.
- Ensure all User and Facility safety precautions are observed.

Cybox 425T Treadmill Owner's Manual

- Carefully read and understand the following before using the 425T treadmill:

- Warning Decals
- Caution Decals

To replace any worn or damaged decals do one of the following: Fax your order to 508-533-5183 or contact Cybex Customer Service at 888-462-9239. If you live outside of the USA, call 508-533-4300. For location or part number of labels, see the parts list and exploded-view diagram.

Warning Decals

Warning decals indicate a potentially hazardous situation, which, if not avoided, could result in death or serious injury. The warning decals used on the Cybex 425T are shown below.

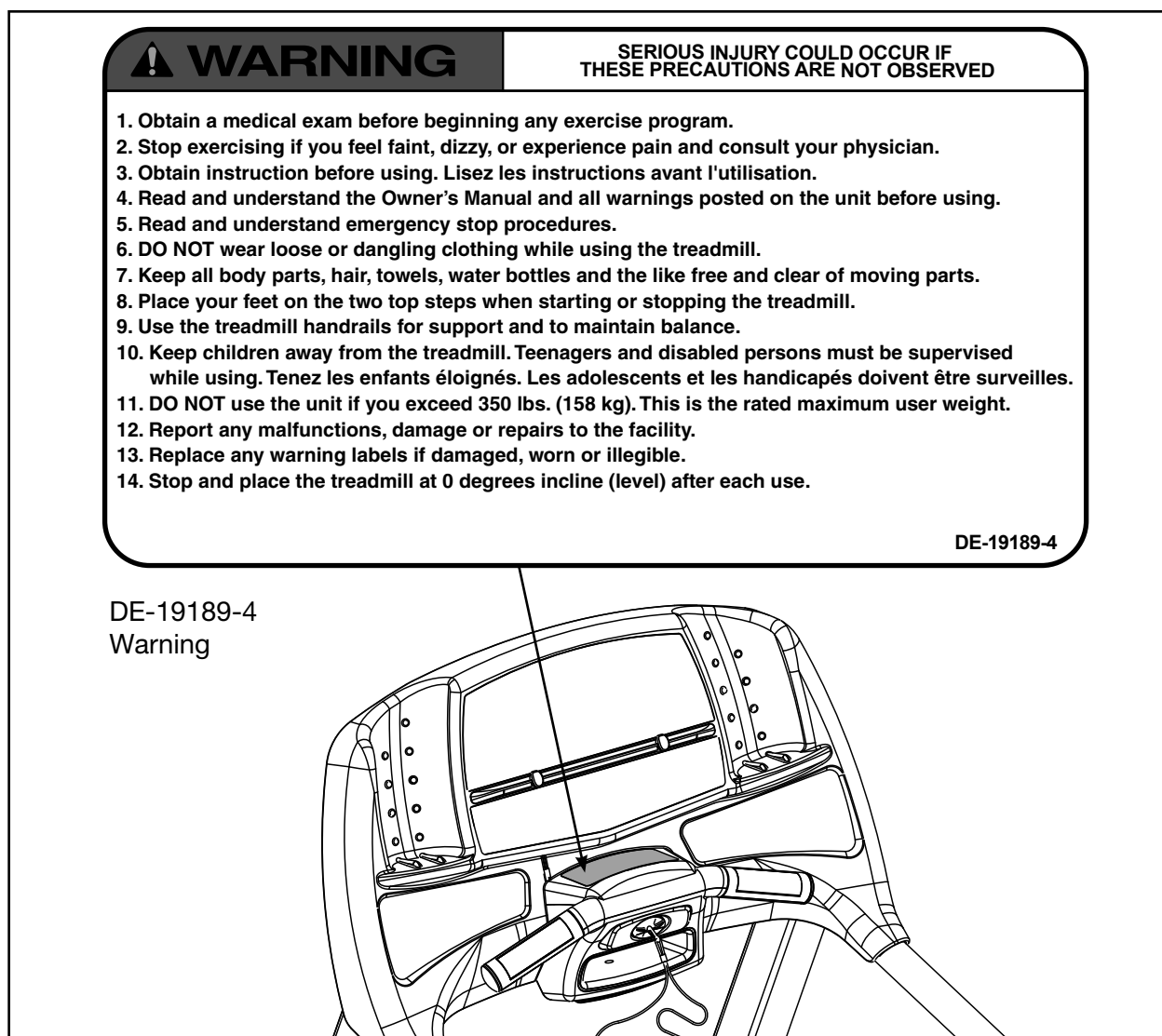

⚠ WARNING
WARNUNG
AVERTISSEMENT
ADVERTENCIA
ПРЕДУПРЕЖДЕНИЕ
VARNING
ADVARSEL 警告

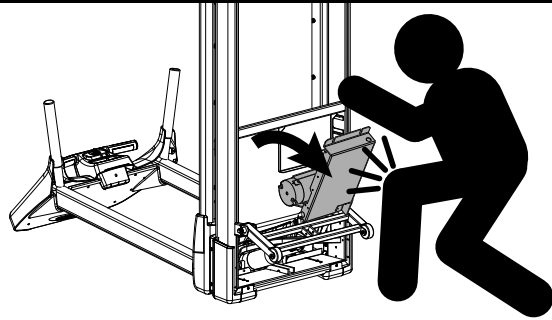

DE-19238

DE-19238
Warning
Motor Cover

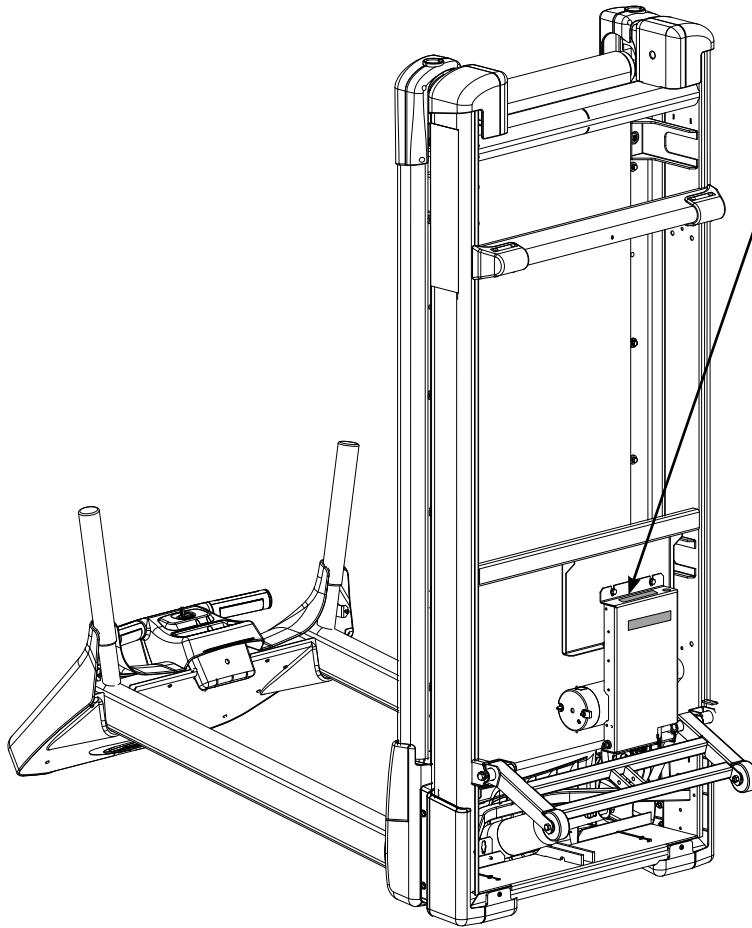

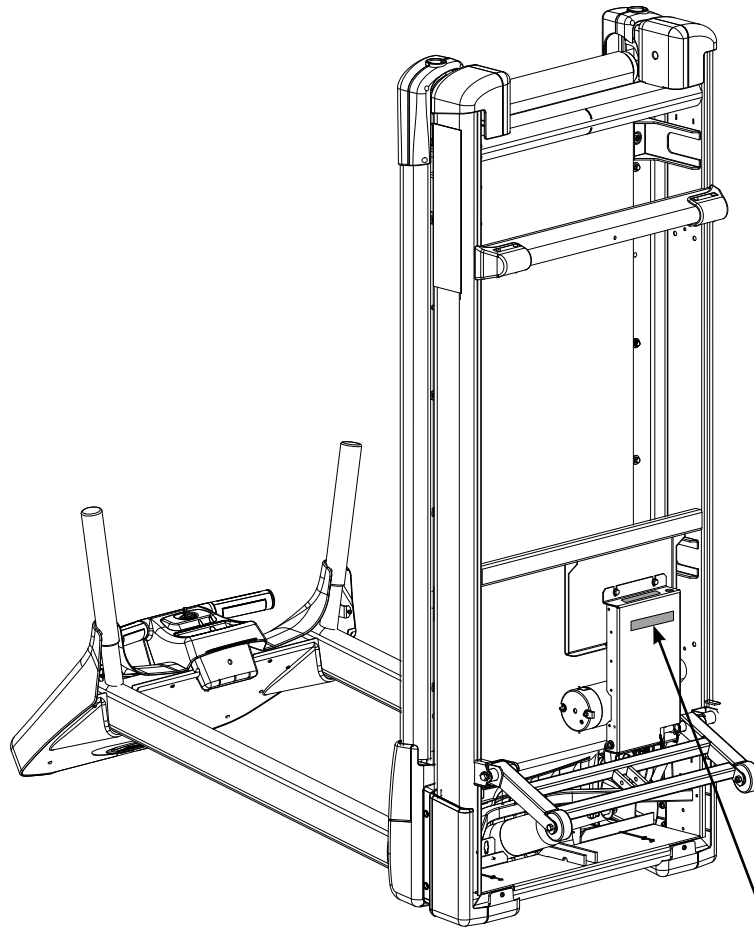

| | | | | |
|---|--|---|--|--|
| | WARNING | WARNUNG | 警告 | ПРЕДУПРЕЖДЕНИЕ |
| | AVERTISSEMENT | ADVERTENCIA | 警告 | VARNING |
| DISCONNECT POWER BEFORE SERVICING. | DÉBRANCHEZ L'ALIMENTATION AVANT DE FAIRE L'ENTRETIEN. | VOR SERVICEAR- BEITEN NETZSTECKER ZIEHEN. | CORTE LA ENERGIA ELECTRICA ANTES DE REPARAR. | 修理点検の前に 電源を 切ってください。 |
| | | | | KOPPLA IFRÅN STRÖMMEN INNAN SERVICE UTFÖRS. |
| | | | | ОТКЛЮЧИТЕ ПИТАНИЕ, ПРЕЖДЕ ЧЕМ ПРИСТУПАТЬ К ОБСЛУЖИВАНИЮ. |

DE-20427 A

DE-20427
Warning
Motor Cover

Caution Decals

Caution decals indicate a potentially hazardous situation, which, if not avoided, may result in minor or moderate injury. There are no caution decals used on this unit. However, there are caution statements listed in Chapters 2 and 5 of this manual. See Chapters 2 and 5.

Emergency Stop Key (e-stop)

The e-stop key functions as the emergency stop. In an emergency situation, remove the e-stop key and the treadmill will come to a stop. Before using the treadmill, clip the e-stop key as described below.

1. Clip the e-stop key to your clothing. **NOTE: Be sure the string is free of knots and has enough slack for you to run comfortably with the e-stop key in place.**
2. Without falling off the treadmill, carefully step backward until the e-stop falls off the treadmill. **NOTE: If the e-stop clip falls off your clothing then the test has failed. Reclip the e-stop clip to your clothing and repeat this step.**
3. Replace e-stop after successfully testing the e-stop key. See the illustration shown below.
4. The treadmill is now ready to be used.

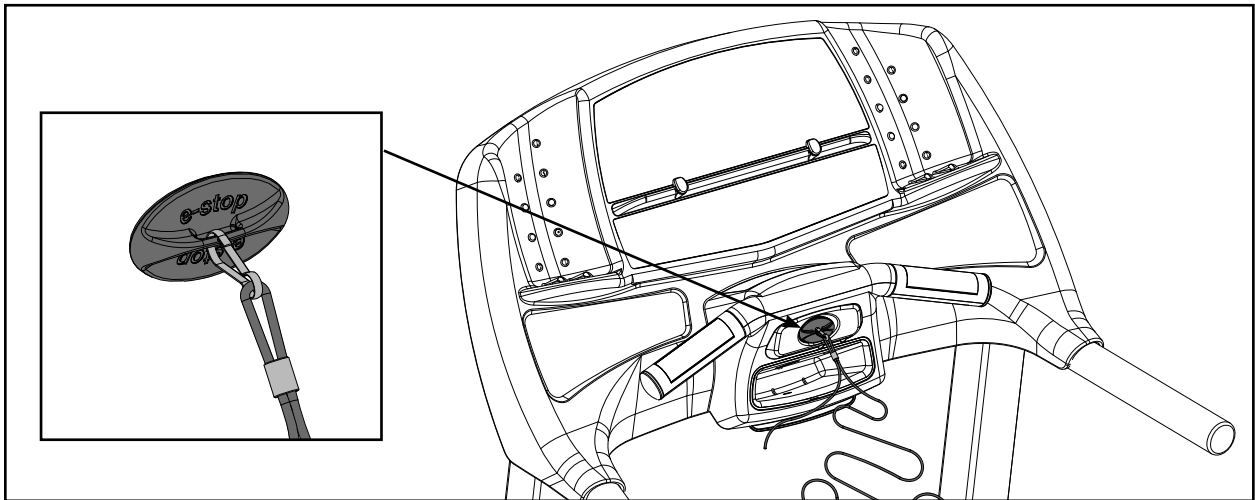

5. After use, remove the e-stop key from the treadmill.

NOTE: The e-stop key shall be removed to help prevent unauthorized use. Refer to the *Stopping the Treadmill* section in the *Operation* chapter for more information about the e-stop key.

This page intentionally left blank

2 - Assembly and Setup

Warnings/Cautions

All warnings and cautions listed in this chapter are as follows:



WARNING: Use extreme caution when assembling the treadmill. Failure to do so could result in injury.



WARNING: During this procedure **STAY OFF THE RUNNING BELT!** Stand with your feet on the two steps.



CAUTION: A minimum of two people are required to lift, move and assemble this treadmill. Always use proper lifting methods when moving heavy items.

Choosing and Preparing a Site

Before assembling the treadmill you must select a suitable site and have the proper electrical outlet power available for optimum operation and safety. See the *Electrical Power Requirements* section (located on the next page) for direction in locating your treadmill's voltage requirements.

The area you select for the treadmill should be well lit and well ventilated. Locate the treadmill on a structurally sound and level surface (do not place in recessed areas or on plush carpet) a few feet away from walls and other equipment. Each side of the treadmill should have a 19.7" (0.5 m) minimum space. Behind the treadmill should be 79" (2.0 m) minimum of space. Allow enough clearance for safe access and passage during use of the machine. If the treadmill is to be located above the first floor, place it near or above major support beams. If the area has a heavy, plush carpet, the airflow around the base of the machine may be restricted or the carpeting may interfere with the moving parts. To protect the carpeting and the machinery, place a 3/4" (1.9 cm) thick wood base under the treadmill.

Do not install the treadmill in an area of high humidity, such as in the vicinity of a steam room, sauna, indoor pool, or outdoors. Exposure to extensive water vapor, chlorine, and/or bromine could adversely affect the electronics as well as other parts of the machine.

Electrical Power Requirements

The power requirements for this treadmill are a grounded, dedicated circuit, rated for one of the following: 115 VAC \pm 5%, 60 Hz and 15 amps; 208/220 VAC, 60 Hz, 100 amps or 230 VAC \pm 5%, 50 Hz and 10 amps. Contact your electrician to ensure the power supply complies with local building codes.

Do not use a ground plug adapter to adapt the 3-prong power cord plug to a non-grounded electrical outlet. Do not use an extension cord.

Assembling the Treadmill



WARNING: Use extreme caution when assembling the treadmill. Failure to do so could result in injury.



CAUTION: A minimum of two people are required to assemble this treadmill.

Tools Required

- 9/16" Socket wrench with a 4" extension
- Phillips screwdriver

NOTE: The words "left" and "right" denote the treadmill user's orientation.

1. Read and understand all instructions thoroughly before assembling the treadmill.

NOTE: Each step number in the assembly instructions tells you what you will be doing. The lettered steps following each step number describe the procedure required. Do not continue with step 2 until you have carefully read all of the assembly instructions.

2. Verify you have received the correct package.

- A. Read the sticker on the outside of the box and verify that the model number, color and voltage are what you ordered. **NOTE:** During step 3 and 5 you will verify that the contents of the box match the sticker.

3. Unpack and verify the contents of the boxes.

- A. Lift up and remove the cardboard sleeve that surrounds the treadmill.
- B. Check to be sure that the following items are present. Check off () each item as you find it. See Figure 1. If any of the parts are missing contact Cybex Customer Service.

Cybex 425T Treadmill Owner's Manual

| Item | Qty | Part Number | Description |
|-----------------------------|-----|-------------|-----------------------------|
| <input type="checkbox"/> 1 | 1 | Varies | Base assembly |
| <input type="checkbox"/> 2 | 1 | Varies | Console assembly |
| <input type="checkbox"/> 3 | 1 | NA | Upright assembly |
| <input type="checkbox"/> 4 | 1 | AX-19027 | Console back |
| <input type="checkbox"/> 5 | 1 | PL-19061 | Cover, console back |
| <input type="checkbox"/> 6 | 1 | AX-19239 | Motor cover, center |
| <input type="checkbox"/> 7 | 1 | PL-18991 | Motor cover, right (in box) |
| <input type="checkbox"/> 8 | 1 | PL-18992 | Motor cover, left (in box) |
| <input type="checkbox"/> 9 | 1 | AX-19354 | Hardware pack (in box) |
| <input type="checkbox"/> 10 | 1 | LT-19341-4 | Owner's manual (in box) |
| <input type="checkbox"/> 11 | 1 | LT-19340 | Assembly poster |
| <input type="checkbox"/> 12 | 1 | LT-19339 | Warranty sheet |
| <input type="checkbox"/> 17 | 1 | AX-20944 | Assembly, E-Stop Lanyard |

NA means Not Applicable

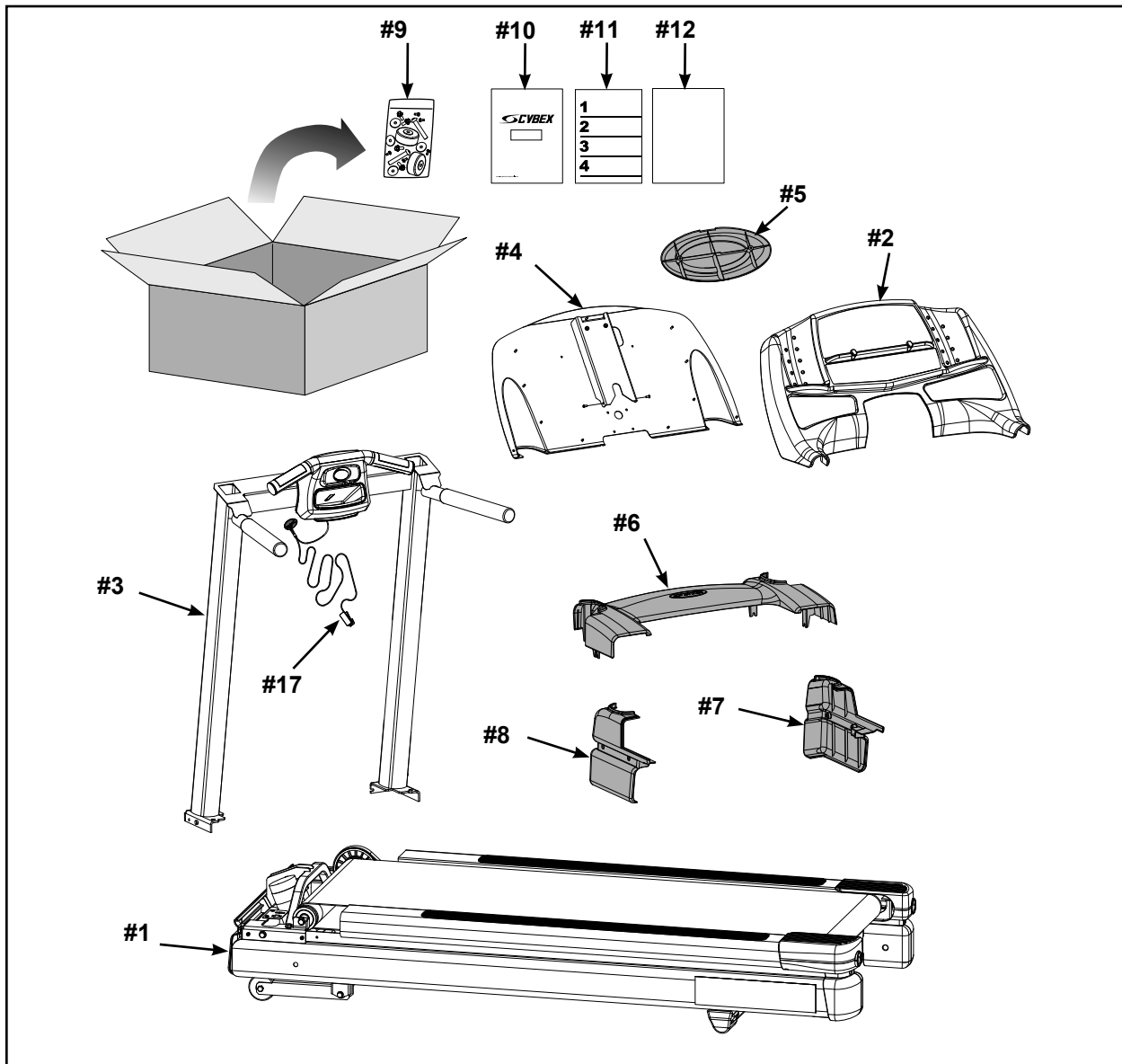

Figure 1

Cybex 425T Treadmill Owner's Manual

C. Check off () each item in the hardware pack as you find it. See Figure 2.

| Item | Qty | Part Number | Description |
|-----------------------------|-----|-------------|---------------------------------------|
| <input type="checkbox"/> 13 | 14 | HS-11977 | Screw, SEMS, 8-32 x .38", PNHD PHIL |
| <input type="checkbox"/> 14 | 9 | HS-15706 | Screw, 8-16 x .50", PNHD, STL, BLK |
| <input type="checkbox"/> 15 | 6 | HS-16929 | Bolt, Whiz Lock, 3/8-16 x .625", HXHD |
| <input type="checkbox"/> 16 | 4 | HS-16939 | Screw, SEMS, 10-32 x .75", PNHD, BLK |

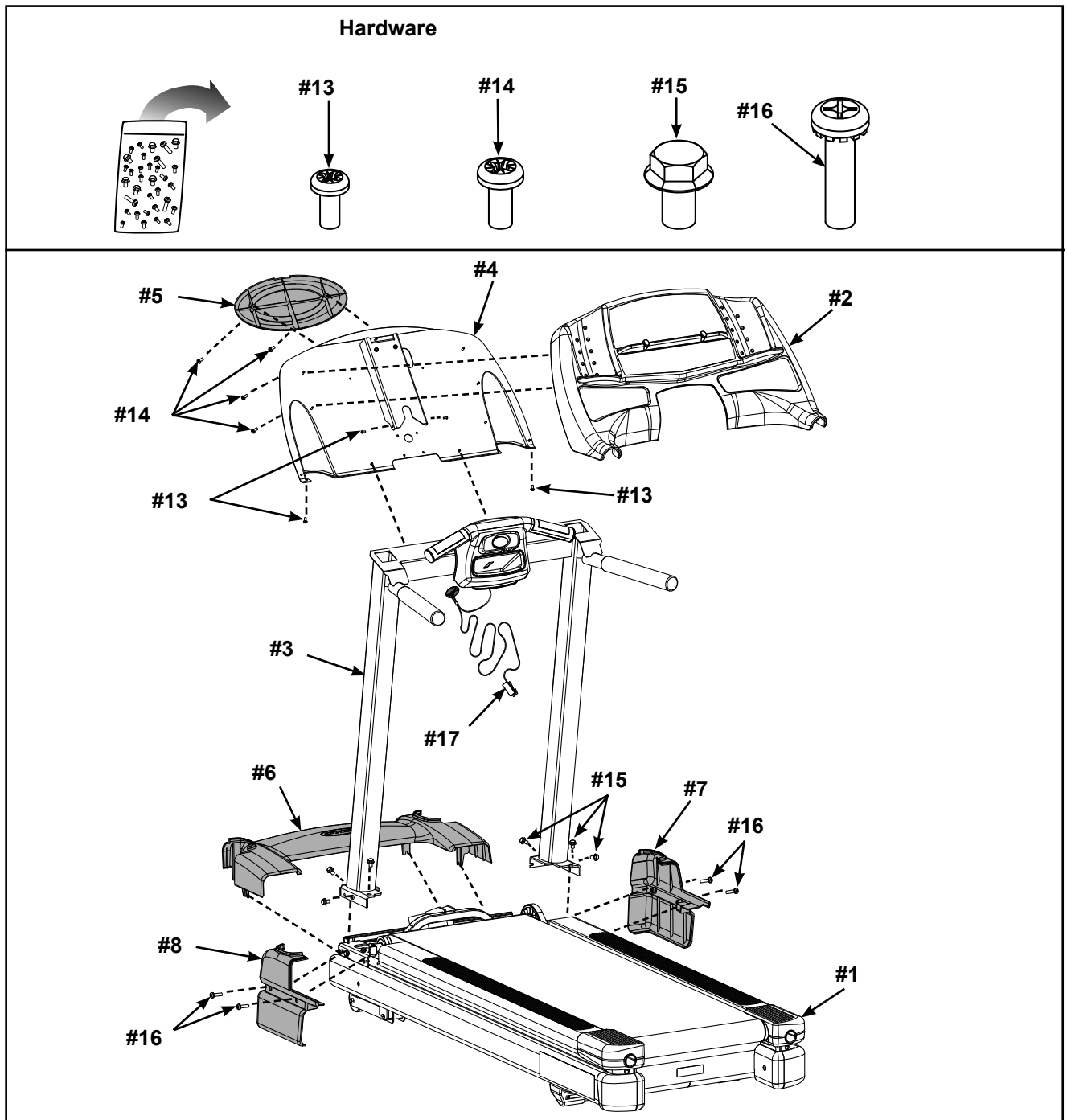

Figure 2



CAUTION: *A minimum of two people are required to lift, move and assemble this treadmill. Always use proper lifting methods when moving heavy items.*

4. Lift and move the treadmill.

- A. At least two people should lift and move the treadmill to a level location where you intend to leave it. Use proper lifting methods.

5. Verify the model and voltage.

- A. Verify that you have the correct model and voltage by looking at the serial number label located at the rear of the unit..

6. Install the upright assembly.

- A. Locate the upright assembly (#3) and six bolts, 3/8-16 x .625" (#15).

NOTE: *Do not pinch or damage display cable when installing upright assembly.*

- B. Carefully place the upright assembly (#3) on the base assembly (#1) as shown. See Figure 3.
- C. Plug the display cable, located at the bottom of the upright assembly (#3) into the base assembly (#1). See Figure 3.
- D. Carefully lift the upright assembly (#3) into the proper location. See Figure 4.
- E. Using a 9/16" socket wrench, secure the upright assembly (#3) to the base assembly (#1) with six bolts, 3/8-16 x .625" (#15). See Figure 4.

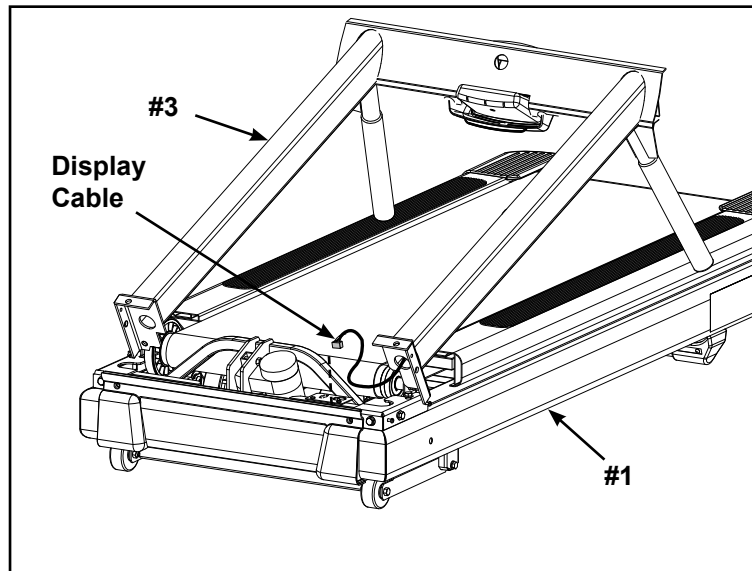

Figure 3

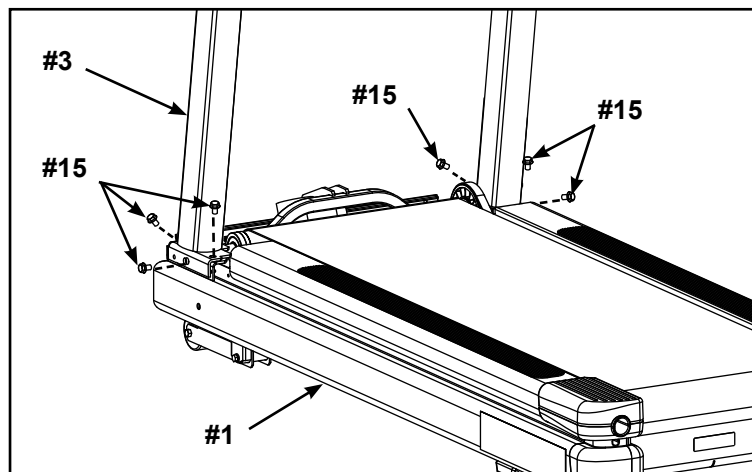

Figure 4

7. Install the console back to the upright assembly.

- A. Locate the console back (#4) and twelve screws, 8-32 x .38" (#13).
- B. Place the console back (#4) in the correct position on the upright assembly (#3). See Figure 5.

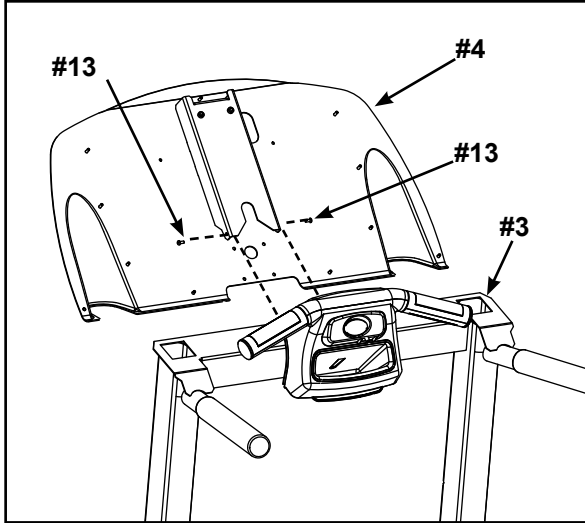

Figure 5

- C. Using a Philips head screwdriver install two screws 8-32 x .38" (#13) to hold the console back (#4) in place. Do not fully tighten at this time. See Figure 5.
- D. Using a Philips head screwdriver secure the console back (#4) to the upright assembly (#3) using ten screws 8-32 x .38" (#13). Fully tighten the two screws installed in step 7C. See Figure 6.

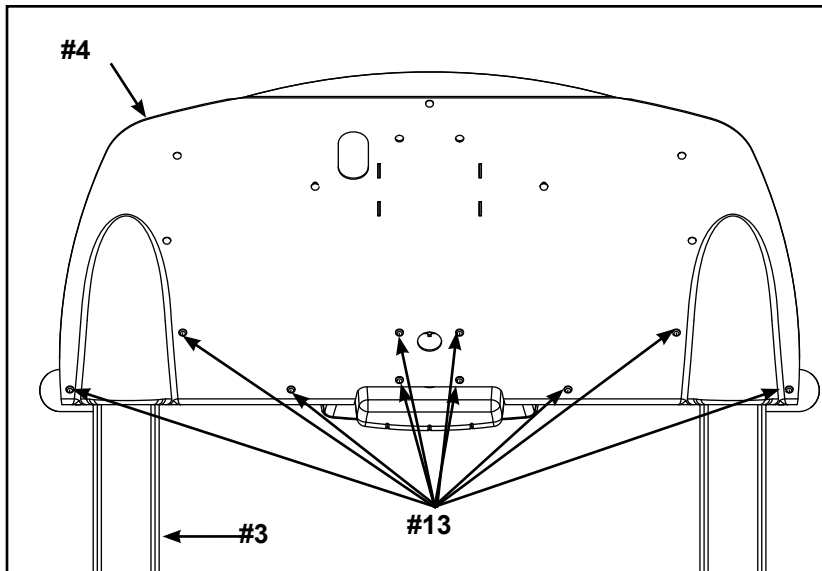

Figure 6

NOTE: If installing the A/V option, refer to the 425T A/V bracket installation instructions (supplied with the A/V bracket).

8. Install the console assembly to the console back.

- A. Locate the console assembly (#2), two screws, 8-32 x .38" (#13) and nine screws 8-16 x .50" (#14).
- B. Place the console assembly (#2) in position on the console back (#4). See Figure 7.

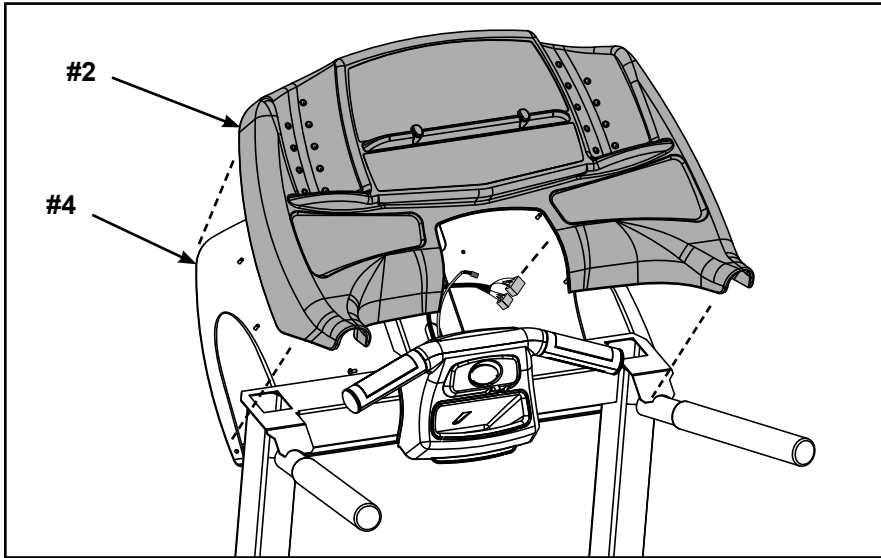

Figure 7

- C. Connect these cables into the display board: the display cable (2 connectors), the contact heart rate cable and the ground wire. See Figure 8.

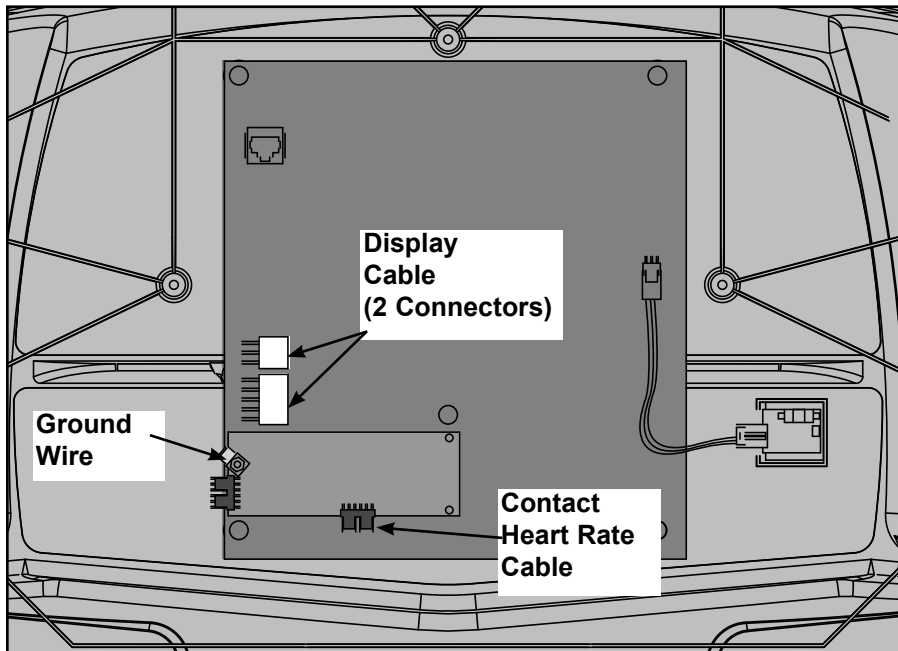

Figure 8

- D. Check to see that all of the cables are connected firmly in their proper place. See Figure 8.
- E. While being sure not to pinch any cables, use a Phillips head screwdriver to secure the seven screws 8-16 x .50" (#14) that hold the console assembly (#2) to the console back (#4). See Figure 9.
- F. Using a Phillips head screwdriver secure the two screws (#13) securing the console assembly (#2) to the upright assembly (#3). See Figure 9.
- G. Using a Phillips head screwdriver secure the two screws (#14) securing the console back cover (#5) to the console front (#4). See Figure 10.

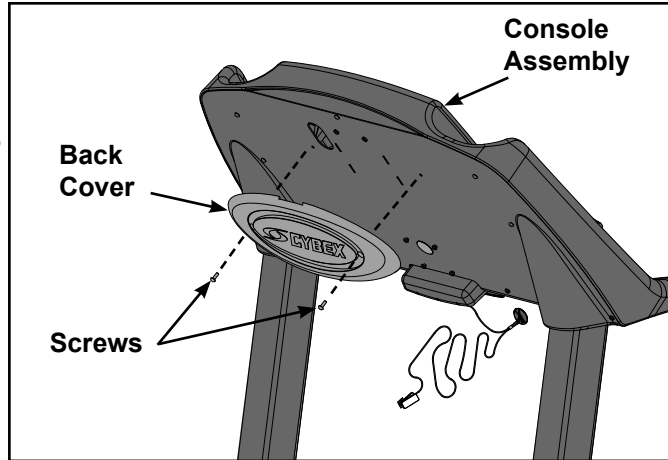

Figure 9

9. Attach the motor cover (three pieces).

- A. Using a Phillips screwdriver, partially tighten each motor cover side (left and right) with four screws, 10-32 x .75" (#16). See Figure 10.
- B. Place the motor cover center (#6) into position. See Figure 11.
- C. Using a Phillips screwdriver, finish tightening all four screws. Be sure the screws are securing the motor cover's tabs.

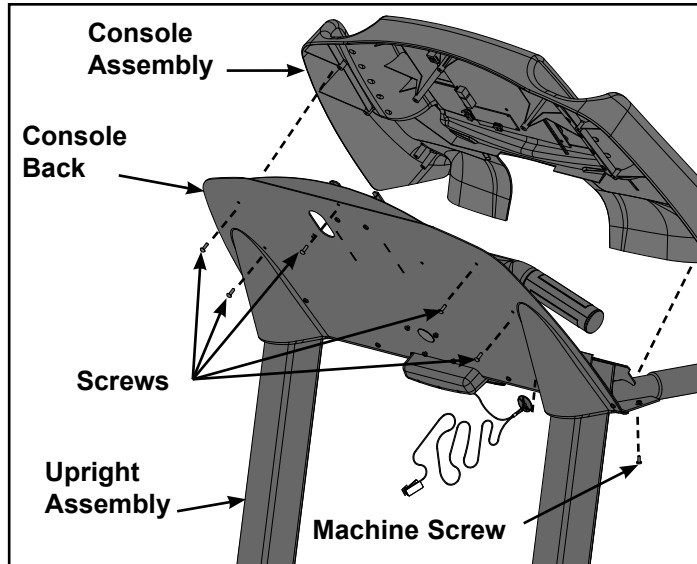

Figure 10

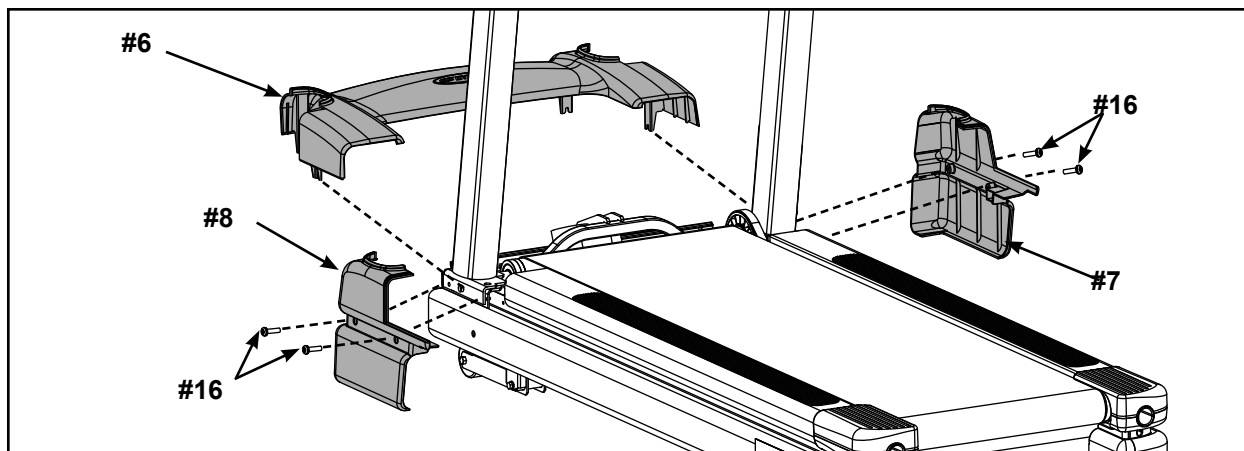

Figure 11

10. Level your treadmill.

- A. Confirm that your treadmill is on a level surface.

11. Attach emergency stop key.

- A. Confirm that the emergency stop key is in place over the e-stop button. See Figure 12. **NOTE:** *The treadmill will not run without the key (or other metal) in place.*

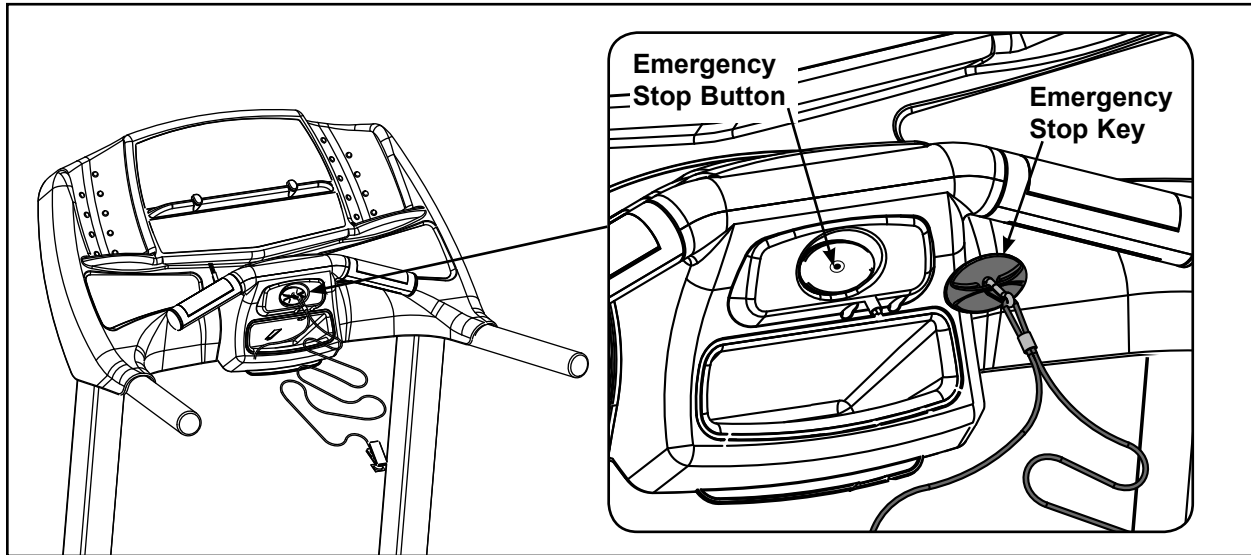

Figure 12

12. Properly route power cord.

- A. Route power cord away from pinch points such as the elevation assembly. See Figure 13.

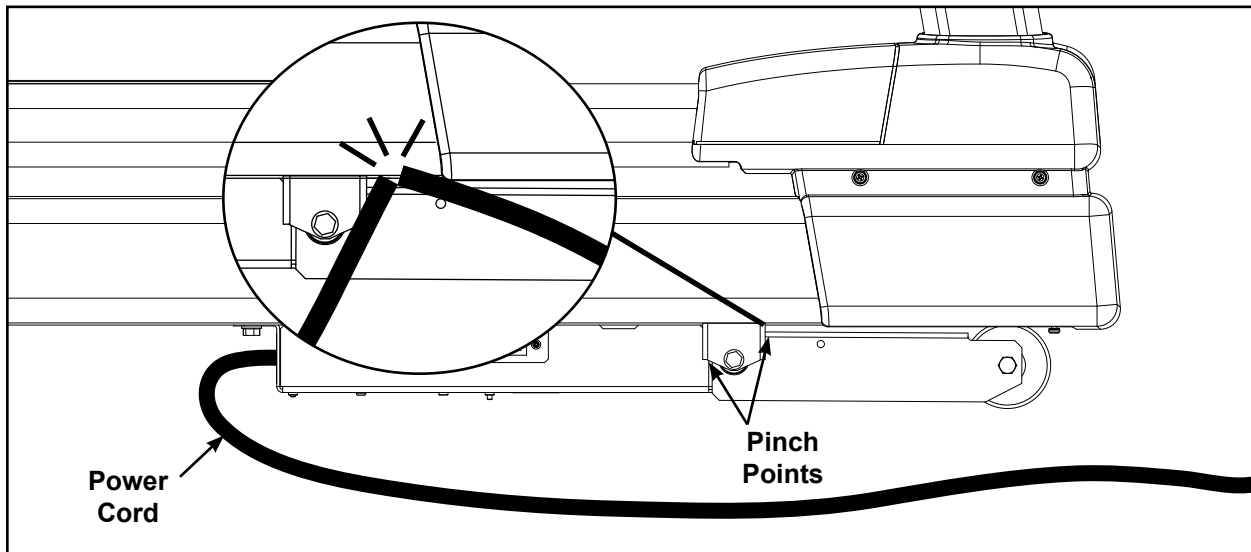

Figure 13

13. Visually inspect the treadmill.

- A. Carefully examine the treadmill to ensure that the assembly is correct and complete.



WARNING: *Be sure that all electrical requirements are met as indicated in the specifications at the front of the manual and at the beginning of this chapter prior to proceeding.*

Testing the Treadmill Operation

Use the following instructions to test the full speed and incline range of the treadmill and to check the belt for proper operation.





CAUTION: *During this procedure STAY OFF THE RUNNING BELT! Stand with your feet on the two steps.*

1. Without anyone on the treadmill, plug the power cord into a power outlet from a grounded, dedicated circuit as described under *Electrical Requirements* in this chapter.
2. The control panel will light up and be in the *Dormant Mode*.

NOTE: *Cybex recommends that the treadmill be unplugged when it is not in use.*

3. Press the **Quick Start** key. The treadmill begins a countdown "3...2...1" and sounds a tone for each count. After it reaches one (1), the treadmill gives a shorter tone and then begins accelerating the belt to reach 0.5 mph (0.8 kph).
4. The bottom left display will flash the time and the right display will show the actual speed.
5. Press and hold down the **Speed +** key until the treadmill reaches a speed of approximately 4 mph (6.4 kph), as indicated on the display.
6. Observe the belt to see that it is running properly; it should stay centered in the middle of the deck. If you have problems with the running belt operation, see *Running Belt Adjustments* in the *Preventive Maintenance* chapter.
7. Run the treadmill through its full speed range. First press the **Speed +** key until the treadmill reaches its highest speed, 11.0 mph (17.6 kph). Then press the **Speed -** key until the treadmill is back to 0.5 mph (0.8 kph).
8. As you press the **Incline \wedge V** or **Speed +** - keys, the respective displays will show the actual incline or speed.
9. When the treadmill reaches the set incline and speed, the displays will remain steadily illuminated to indicate that the desired settings have been reached.

11. Run the treadmill through its full % grade range. Press the **Incline**  key until the treadmill reaches its highest grade (15%). Then press the **Incline**  key until the treadmill is back to 0% grade.
12. Press **Stop** twice to stop the running belt, end the workout review, and return the display to *Dormant Mode*.

Setting Operation Options

1. While in *Dormant Mode* enter *Test Mode* by holding down the **Heart Rate** and **Level** keys simultaneously for five seconds. **NOTE:** To exit *Test Mode*, press the **Pause/Stop** key.

NOTE: After changing any value, you must press **Enter** to save that value. When you press enter the display will read “updt” (updated) to confirm your selection.

2. Press the **Time** key to set options, change values with **A** and **V** keys and press **Enter** to save your selection. Each time you press **Time** the next set of data is displayed in the following order:

Unit — Choices are “Eng” or “Euro” measurements. English is the default.

Line — This is the frequency of the power line that supplies power to your treadmill. The default setting is 50 Hz for metric consoles and 60 Hz for English consoles. **NOTE:** If you have an English console and a 50 Hz power line frequency, then you must change the default setting from 60 Hz to 50 Hz for the proper elevation frequency.

Scan — This turns on or off the data readout scan (unless a specific data key is pressed during a workout). Default is on.

Def — This is the default time for time based programs if a user doesn't re-set **Time**. For example, if you press **Time** you can decrease or increase the set workout time up to the amount that the **Max** time is set. Choices are between 20 minutes and 60 minutes. Default is 20.

Max — This is the maximum amount of time the treadmill can run per use. You can limit the users time or choose “none” for unlimited time. Choices are between none and 120 minutes; default is 60. **NOTE:** If the **Max** time is limited too much it may be difficult for the user to reach their goals. For example, a user may not be able to burn 300 calories if you limit their **Max** time to 20 minutes.

Idle (or Workout Review/Pause Time): — This is how long the treadmill retains and displays your current workout data during a pause in the workout or after a workout. Choices include: 20 seconds; 30 seconds, 40 seconds; 1 minute and 5 minutes; default is 20 seconds.

SPD — This is the maximum speed the treadmill will run. Choices are between 1 and 11 MPH (1.6 to 17.6 kph).

ELV — This is the maximum elevation the treadmill will incline. Choices are between 0 and 15 percent grade.

Remember: You must press **Enter** after changing a value for that value to be stored.

3. To exit *Test Mode* press the **Pause/Stop** key once.

Your treadmill is now ready for use. Follow the instructions in the *Operation* chapter to learn how to operate the treadmill. You should begin with walking speeds first, to be sure everything is functioning properly.

This page intentionally left blank

3 - Operation

Read and understand all instructions and warnings prior to using the treadmill. See all of the safety related information located in chapter 1.

Terms and Symbols Used

This section lists some of the common terms and symbols used in this chapter. Other terms and symbols are listed in this chapter as appropriate.

Dormant Mode — This occurs when the treadmill is plugged in and not in use. The control panel LEDs will flash when the treadmill is in *Dormant Mode*.

Program Setup Mode — This begins after pressing any program key. Upon entering a program the LEDs flash, prompting the user to adjust the appropriate settings.

Active Mode — *Active Mode* is when the running belt is moving. The beginning of *Active Mode* is marked by the three second countdown and running belt acceleration. *Active Mode* continues until you reach the preset time limit, disengage the e-stop key or press the **Pause/Stop** key.

Quick Start — This begins by pressing the **Quick Start** key. **Quick Start** skips the *Program Setup Mode* and begins immediately in *Manual Mode*.

Manual Mode — In this active mode you control all aspects of your workout; the running speed, the incline and the workout duration. As a program choice, **Manual** will prompt for time and user weight and after the 3-2-1 countdown will start the belt at the minimum speed. As **Quick Start** the time will count up, allowing you to quickly get moving before entering your weight by pressing the **Weight** key.

Workout Review — This begins after pressing the **Pause/Stop** key once or at the end of a program. The workout statistics accumulated during the previous workout session will display for preset pause time or until **Pause/Stop** is pressed again.

Pause Mode — Press the **Pause/Stop** key to pause your workout. While in *Workout Review* you can press the **Quick Start** key to resume your workout. All accumulated user statistics are maintained.

Cool Down — This begins immediately after pressing the **Cool Down** key. The countdown timer is set to two minutes, elevation returns to 0% and speed is reduced to 50% of the MET level or 2.5 MPH (4 Km/H) whichever is lower. Repeated presses of the **Cool Down** key will restart the clock at two minutes indefinitely.

▲ ▼ — These keys adjust **Level, Speed, Time** or **Weight** up or down.

Incline ▲ ▼ — These keys adjust **Incline** higher or lower.

+ — — These keys adjust **Speed** up (**+**) or down (**—**).

Quick Operation Guide

NOTE: Maximum user weight is 350 lbs. (159 kg).

The following is a quick overview of the operation of the treadmill. For more information read *Detailed Operation Guide* in this chapter.



1. Place your feet on the two top steps located on each side of the running belt.

WARNING: Do not stand on the running belt when starting the treadmill. Always place your feet on the two top steps when beginning a workout.

2. Clip the e-stop clip onto your clothing and test it as described under *Emergency Stop* in the *Safety* chapter.
3. Press any program key or press **Quick Start** to skip the settings and begin *Manual Mode* immediately.
4. If you pressed a program key to select a program, you will now be prompted for workout **Time**, **Level** and **Weight** as appropriate. Adjust these settings with the **▲ ▼** arrows and press **Enter** to proceed.
5. The treadmill begins a countdown, “3...2...1,” after which it accelerates the belt to 0.5 mph (0.8 kph) (for *Manual Mode*) or the speed of the program that you selected.
6. Hold the handrails while you step onto the running belt and begin walking.
7. Press the **Speed + –** keys to change the belt speed at any time. The right display will show the current speed.
8. Press the **Incline ▲ ▼** keys to change the incline at any time. The left display will show the current incline on the first press of the key.
9. Press the **Pause/Stop** key at any time to stop the running belt and return the incline to 0%. Press again to exit to *Dormant Mode*.

Detailed Operation Guide

NOTE: Maximum user weight is 350 lbs. (158 kg).

NOTE: The unit does not have an on/off switch. Plugging the treadmill into a power outlet will supply power to the treadmill and will illuminate the control panel.

1. Plug the treadmill power cord into a power outlet from a grounded, dedicated circuit, rated for one of the following: 115 VAC ±5%, 60 Hz and 15 amps; 208/220 VAC, 60 Hz, 10 amps or 230 VAC ±5%, 50 Hz and 10 amps.



WARNING: Do not stand on the running belt when starting the treadmill. Always place your feet on the two top steps when beginning a workout.

2. Place your feet on the two top steps located on each side of the running belt.
3. Clip the e-stop clip onto your clothing and carefully test the e-stop key to ensure it will activate in case of an emergency. See *Emergency Stop Key (e-stop)* in Chapter 1 for properly testing the e-stop key. Also, see *Stopping the Treadmill* in this chapter for further information about the e-stop key. **NOTE:** Be sure the string is free of knots and has enough slack for you to run comfortably with the e-stop key in place.
4. You now have the option to select a program or enter *Manual Mode*.

To select a program, press the **Programs** key and follow the prompts. Press the **Programs** key multiple times to cycle through the eight programs, or use the center **Λ V** keys. Press **Enter** to select.

Upon entering a program the LEDs flash, prompting you to adjust the appropriate settings. This is referred to as *Program Setup Mode*. If the **Quick Start** key is pressed now, all defaults for that program will be accepted. After 10 seconds, if no key has been pressed, the first default will be accepted. After another 10 seconds the second default will be accepted and so on until the last default. The program will not enter *Active Mode* until you press the **Enter** or **Quick Start** key. If no key has been pressed for 60 seconds after displaying the last default, then the treadmill will return to the *Dormant Mode*.

If you choose to enter *Manual Mode* instead of choosing a program, press the **Quick Start** or the **Manual** key. **NOTE:** No prompts will occur when you press **Quick Start**. While in *Manual Mode*, customize your workout **Speed, Incline** and enter your **Weight** by pressing those keys.

NOTE: For the most accurate calorie count, you must set your correct weight before beginning your workout (including clothing).

NOTE: When selecting a program you must press **Enter** after each adjustment of **Time, Level and Weight**.

5. The treadmill begins a countdown, "3...2...1" and sounds a tone for each count. When it reaches one (1) the treadmill gives a shorter tone and then starts accelerating the belt. In *Manual Mode* the belt will begin accelerating to 0.5 mph (0.8 kph) and the incline will remain at zero percent. In a program the belt will begin accelerating and the incline will change to the corresponding speed and incline of the program and level you selected.
6. Hold the handrails while you step onto the running belt and begin walking.
7. Observe the three display windows. The top center window will scan (every three seconds) through **Distance, Calories, Calories per hour, Mets, Pace and Heart Rate**. Press the **Scan** key to toggle this feature on or off. **NOTE:** Heart Rate is scanned only when you are holding the contact heart rate grips or wearing a Polar® compatible chest strap. The left window will display the time. **NOTE:** During your workout the time will show in the format of minutes:seconds (after 99:59 the display will only show minutes). The right window will display the current speed. See Figure 1.

8. Press the **Speed + —** keys to change the belt speed at any time. The right display will show the set speed.
9. Press the **Incline ^ v** keys to change the incline at any time. The left display will show the current incline only when incline keys are used, then revert to time.

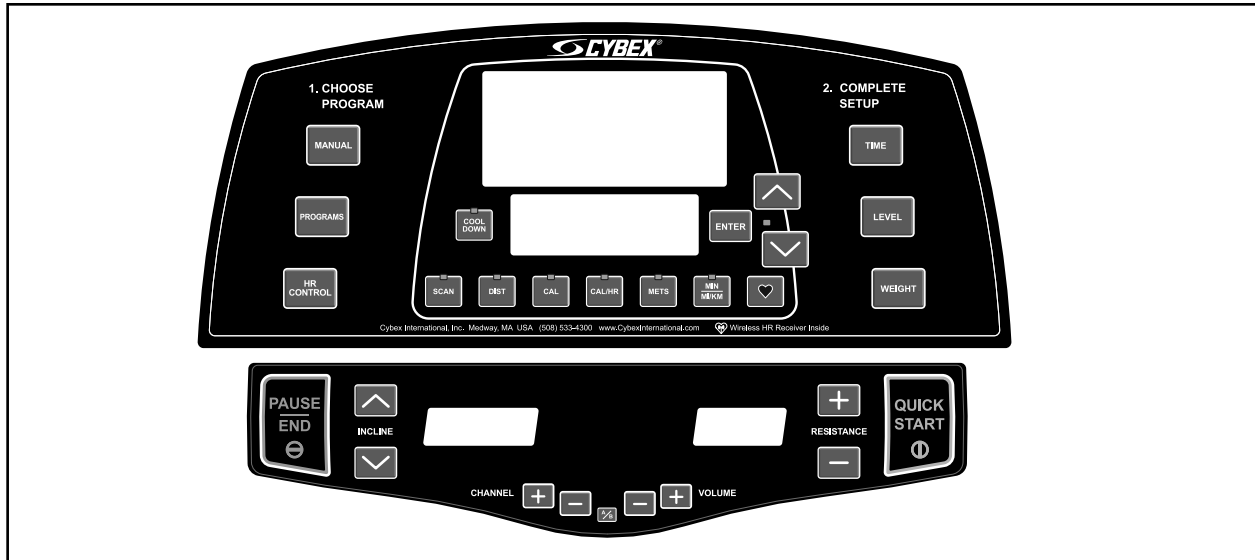

Figure 1

10. Press the **Pause/Stop** key at any time to stop your workout. Press **Pause/Stop** once to end your workout and begin your *Workout Review*. As you press **Pause/Stop** once, the treadmill belt will stop. Press **Pause/Stop** a second time to clear the *Workout Review*, return to *Dormant Mode*.
11. If the e-stop key is removed during a workout, the drive motor power shuts off immediately, causing the belt to stop. The right window changes to “OFF” and the left window shows a flashing pattern of “0” and “o”. Replacement of the e-stop key causes *Workout Review* to begin. Pressing *Quick Start* will resume your workout.
12. When you complete a program the treadmill begins a countdown, “3...2...1,” and sounds a tone for each count. The belt slows to a stop and *Workout Review* displays in the center window for the preset time or until you press the **Pause/Stop** key.
13. The treadmill returns to *Dormant Mode*.

Stopping the Treadmill

Press **Pause/Stop** once to pause your workout for up to 20 seconds (or time set for **idle**) and to enter the **Workout Review**. The belt will stop and workout data will remain in memory for the duration of pause. Press the **Quick Start** key within 20 seconds to continue your workout and add to the time you already accumulated. If the **Quick Start** key has not been pressed during the duration of pause, workout data will be cleared and the display will change to *Dormant Mode*.

Press **Pause/Stop** a second time to interrupt workout data from cycling and to change the display to *Dormant Mode*.

The function of the immobilization method: The purpose of immobilizing the treadmill is to prevent unauthorized use. This can be accomplished by removing the e-stop key from the console, unclipping it from the cord and putting it in a non-accessible place. See Figure 2.

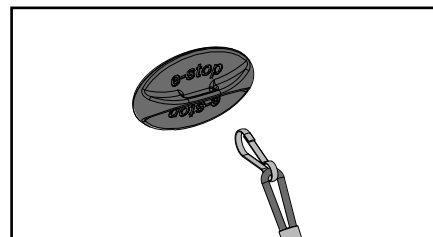

Figure 2

The emergency dismount: Follow the steps listed below if you experience pain, feel faint or need to stop your treadmill in an emergency situation:

1. Grip handrails for support.
2. Step onto the top steps.
3. Pull the e-stop key off the console.

The function of the emergency stop: The e-stop key functions as the emergency stop. In an emergency situation, remove the e-stop key from the console and the treadmill will come to a stop. See Figure 3.

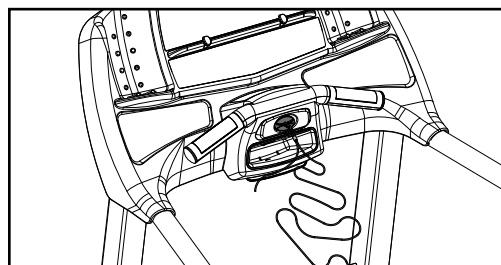

Figure 3

Control During Operation

Control keys on the display are usable during operation and may be pressed at any time to make adjustments in speed, elevation or data readouts.

Changing Speed — Press the **Speed +** — keys to change the speed in increments of 0.1 mph or 0.10 kph. Minimum to maximum speed is from 0.5 - 11.0 mph (0.8 - 17.6 kph).







Changing Incline — Press the **Incline ^ V** keys to change the elevation in increments of 1%. Elevation ranges from 0 to 15%. Press either arrow key once to see the current incline setting, press multiple times to change incline setting. **NOTE: Elevation is defined as the ratio of rise or fall over run of the treadmill deck.**

Workout Time — You can workout up to the maximum time by pressing **Quick Start**.

Changing Data Readouts — Default setting is for scan to start automatically. Press **Scan** to stop and display a set of data. Press **Scan** once again and it will continually review each set of data. The display shows each set of data for 3 seconds before switching to the next set.

Data Readouts

As you exercise, the treadmill keeps track of the following data:

| | |
|---|---|
|  | Distance — The total accumulated distance, in miles or kilometers, during your workout. NOTE: Depending on the defaults you've chosen this measurement will show in English or Metric. |
|  | Calories — The total accumulated calories burned during your workout. Your weight must be correctly set before beginning your workout for this measurement to be most accurate. |
|  | Calories Per Hour - Calculation of present workload's energy exertion in Calories per Hour. |
|  | Metabolic Equivalent — Relates to the user's energy expenditure. A MET is a basic unit of measurement that is used to compare relative work between individuals and activities. 'One MET' is the amount of oxygen consumed at rest. For example two METs would be twice that amount. If an individual were working at four METs he/she would be consuming oxygen at a rate equal to four times their resting consumption. METs can be used to compare walking on a grade with running or even to cycling and other activities. |
|  | Pace — At your current speed, how long it would take to cover a mile (or kilometer), displayed in minutes:seconds. |
|  | Heart Rate — Your current heart rate. Heart rate will appear when a signal is introduced. Use the handgrips for Contact Heart Rate or wear a Polar® compatible heart rate chest strap. |

Data displayed during a program: The top center display will continually review each set of data. Each set of data is displayed for 3 seconds before the next set is displayed. The corresponding LED lights as the data is displayed.

To review accumulated data after a program: The display automatically cycles through your accumulated workout data during the **Workout Review** for up to 20 seconds or the preset idle time.

Displaying Heart Rate

In order for the Cyberx 425T to display your heart rate, hold the handgrips to use Contact Heart Rate or wear a Polar® compatible heart rate chest strap.

Contact Heart Rate — Hold the handgrips on the console handrail until a heart rate is displayed, typically less than thirty seconds. For best results, hold the handgrips lightly and ensure that your hands contact both the front and back sensors of each grip. ***NOTE: Hold your hands as steady as possible as movement can cause interference on the contacts.***

Factors that can interfere with the heart rate signal include:

- excessive movement
- body composition
- hydration
- too loose grip
- too tight grip
- running
- excessive dirt, powder or oil
- leaning or resting on grips

NOTE: Cyberx does not recommend continuous holding onto the contact heart rate grips during exercise.

Contaminants, such as hand lotions, oils or body powder, may come off on the contact heart rate grips. These can reduce sensitivity and interfere with the heart rate signal. It is recommended that the user have clean hands when using the contact heart rate.

Heart Rate Zone

Heart Rate is described by the number of times your heart beats in a minute. At rest, the average adult will have a heart rate of about 72 beats per minute (bpm). As one begins to exercise, heart rate increases and continues to increase as exercise intensity or difficulty increases.

Monitoring your heart rate is an effective way to control the intensity of your workout and subsequently the results it will have. Whether you are a new participant or one with a great deal of experience, weight loss and other performance goals can be achieved by controlling the intensity of your workout.

The American College of Sports Medicine recommends that healthy adults exercise between 55 and 85% of their heart rate max. Your heart rate max can be estimated by subtracting your age from 220. Multiply that estimated heart rate max by .55 to estimate the lower end of your heart rate training zone. Then multiply your estimated heart rate max by .85 to estimate the higher end of your training zone. This heart rate training zone gives you a range of intensities at which to exercise.

NOTE: A label is located on the console to remind you what the heart rate zone is while you are working out. See Figure 4.

Meaning of % Grade

A 1% grade is not the same as a 1 degree incline. The % grade is the relationship of the measurement of rise over the measurement of run (also called slope). For example, a 1 foot (meter) rise in height over a length of 100 feet (meters) is a 1% grade. Expressed as a mathematical formula, the grade is calculated as follows:

$$1 \text{ ft. (m)} / 100 \text{ ft. (m)} = 0.01 = 1\%$$

With respect to treadmills, the percent grade is roughly equal to the increase in height (rise) of the treadmill divided by the length (run) of the treadmill.

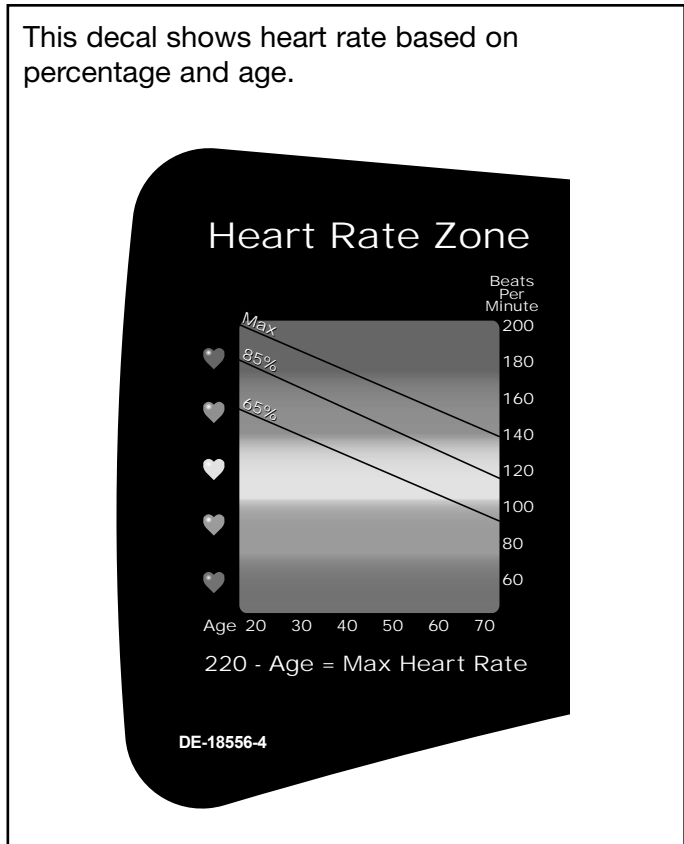

Figure 4

The degree of incline can be related to % grade by taking the Arctangent of the grade. For instance, 15% grade is equal to 8.53 Degrees ($\text{ArcTan}(.15)=8.53^\circ$). The opposite is true to determine % Grade from Degree of incline ($\text{Tan}(8.53^\circ)=.15$).

Use of Programs



WARNING: Obtain a medical exam before beginning any exercise program. Begin comfortably with a lower level and progress with higher levels as you become acclimated.

With the 425T, you may choose from eight different programs as well as *Manual* and *HR Control*. The program choices are summarized as follows:

| | | |
|------------------------------|-----------|---|
| Quick Start | | You control speed, elevation. Adjust time and weight. |
| Manual Mode | | Enter time and weight. You control speed, elevation. |
| Speed Interval 1 (P1) | 10 Levels | Select time, level and weight. |
| Speed Interval 2 (P2) | 10 Levels | Select time, level and weight. |
| Hill Interval (P3) | 10 Levels | Select time, level and weight. |
| Pikes Peak (P4) | 10 Levels | Select time, level and weight. |
| Rolling Hills (P5) | 10 Levels | Select time, level and weight. |
| Hills (P6) | 10 Levels | Select time, level and weight. |
| Weight Loss (P7) | 10 Levels | Select time, level and weight. |
| Cardio (P8) | 10 Levels | Select time, level and weight. |
| HR Control | | Select time, target heart rate and weight. |



Audio / Video

Audio and video options are available. If unit is supplied with a personal entertainment monitor (television) or a wireless transceiver, the use of the controls at the center of the handgrips will control A/V options. See Figure 5.

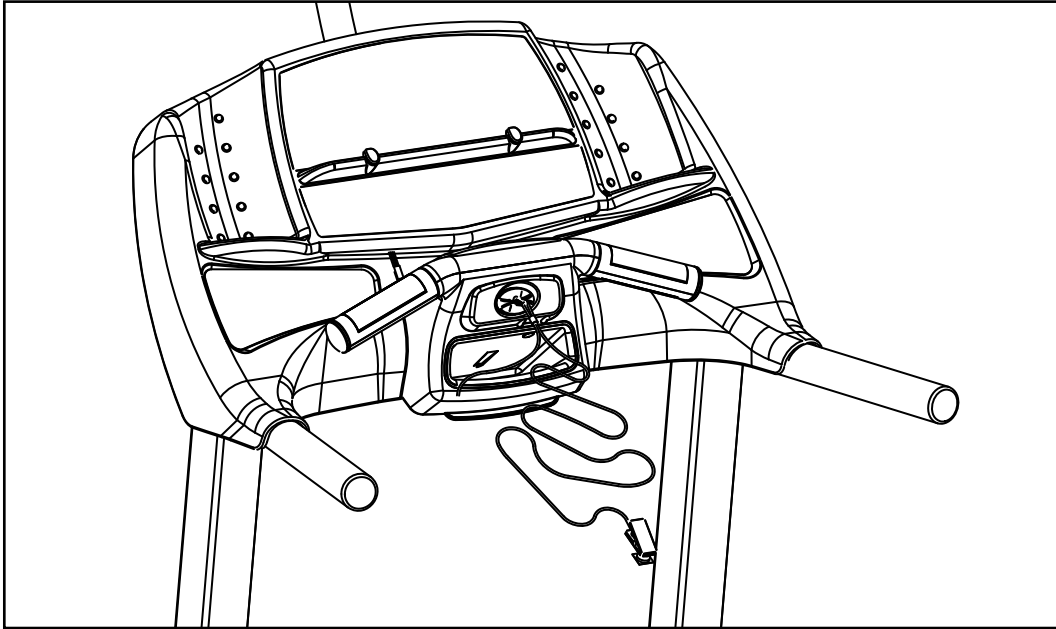

Figure 5

A/V keys are active throughout all user modes to perform their specified functions. See Figure 6.

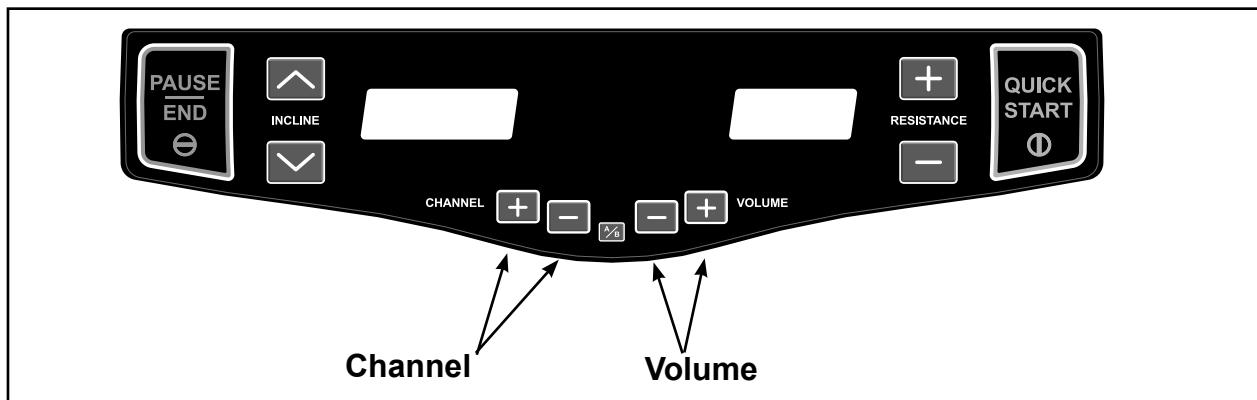

Figure 6

CHANNEL up/down are active to make changes to channel.

VOLUME up/down are active to make changes to volume.

4 - Preventive Maintenance

Warnings/Cautions

All warnings and cautions listed in this chapter are as follows:



WARNING: All maintenance activities shall be performed by qualified personnel. Failure to do so could result in serious injury.



WARNING: To prevent electrical shock, be sure that the treadmill is unplugged from the electrical outlet before performing any cleaning or maintenance procedures.



WARNING: Keep wet items away from inside parts of the treadmill. Electrical shock could occur even if the treadmill is unplugged. Do not touch components on the lower board. A charge can remain after unplugging the power cord and turning off the treadmill.

Regular Maintenance Activities



WARNING: All maintenance activities shall be performed by qualified personnel. Failure to do so could result in serious injury.

Preventive maintenance activities must be performed to maintain normal operation of your treadmill. Keeping a log sheet of all maintenance actions will assist you in staying current with all preventive maintenance activities. See *Service Schedule* located at the end of this chapter.

NOTE: Worn or damaged components shall be replaced immediately or the treadmill removed from service until the repair is made.

NOTE: Cybex is not responsible for performing regular inspection and maintenance actions for your treadmill. Instruct all personnel in equipment inspection and maintenance actions and also in accident reporting/recording. Contact Cybex Customer Service at 888-462-9239 or 508-533-4300 for any preventive maintenance or service concerns.

Cleaning Your Treadmill

When cleaning your treadmill spray a mild cleaning agent, such as a water and dishsoap solution, on a clean cloth first and then wipe the treadmill with the damp cloth.

NOTE: Do not spray cleaning solution directly on the treadmill. Direct spraying could cause damage to the electronics and may void the warranty.



WARNING: To prevent electrical shock, be sure that the treadmill is unplugged from the electrical outlet before performing any cleaning or maintenance procedures.

After Each Use — Wipe up any liquid spills immediately. After each workout, use a cloth to wipe up any remaining perspiration from the handrails and painted surfaces.

Be careful not to spill or get excessive moisture between the edge of the display panel and the console, as this might create an electrical hazard or cause failure of the electronics.

As Needed — Vacuum any dust or dirt that might accumulate under or around the treadmill. Motors are especially susceptible to dust and dirt, and restricted airflow can prevent adequate cooling that could shorten motor life. Cleaning this area should be done as often as indicated in the *Service Schedule*.



WARNING: Keep wet items away from inside parts of the treadmill. Electrical shock could occur even if the treadmill is unplugged. Do not touch components on the lower board. A charge can remain after unplugging the power cord.

To clean the motor components, you must raise the elevation to 15% elevation. Unplug the treadmill and carefully lift the rear of the treadmill. Lift the treadmill until it rests on the top of the console. Use a vacuum attachment or hand vacuum to clean the exposed elevation assembly, drive motor, lower electronics and the surrounding areas. Wipe clean the underside of the treadmill to prevent dirt and dust build-up.

Also use a dry cloth for the areas that you can't reach with the vacuum cleaner. If the machine has not been used for some time or is excessively dirty, use a dry cloth to wipe all exposed areas.

Carefully lower the rear of the treadmill and roll it back from its present position to vacuum the floor area underneath the unit. When finished, return the treadmill to its normal position.

Contact Heart Rate Grips — Contaminants, such as hand lotions, oils or body powder, may come off on the contact heart rate grips. These can reduce sensitivity and interfere with the heart rate signal. It is recommended that the user have clean hands when using the contact heart rate. Clean the grips using a cloth dampened with a cleaning solution containing rubbing alcohol. The grips are the only part of the treadmill you should use a cleaning solution containing rubbing alcohol.

Running Belt Maintenance

Belt and Deck — Wipe the belt surface and the deck area with a clean dry towel to minimize the effect of friction between the deck and the running belt. This should be done often to prevent premature wear of the deck, running belt, and the drive motor system. See the *Service Schedule* at the end of this chapter.

The running belt may become loose and slip on the drive roller with each foot plant. If it does, follow the Tensioning and Centering the Belt procedure below. See the *Service Schedule* in this chapter for a minimum schedule for checking the belt tension.

Tension and Center the Belt — If the belt is slipping under each step perform this procedure:

Tools Required

- 3/4" Socket wrench

1. Tension the belt.

- A. Use a 3/4" socket wrench to turn each bolt 1/2 turn clockwise. See Figure 1. **NOTE:** Be sure to adjust each bolt equally on each side.

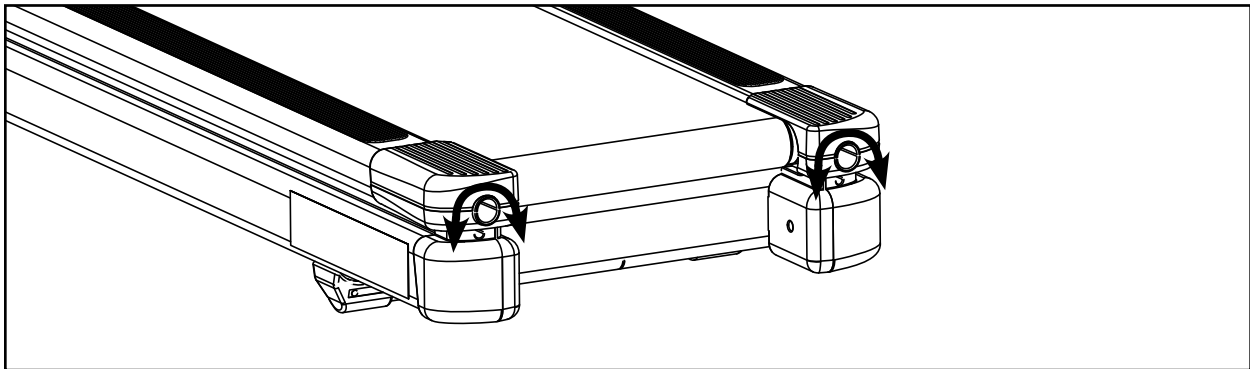

Figure 1

- B. Press the **Quick Start** key.
- C. Press the **Speed +** key to bring the speed up to 3.5-4 mph (5.6-6.4 kph). Allow the treadmill to run for a minute.
- D. Observe the belt to be sure it stays centered. If it is not centered follow step 2.
- E. Walk on the belt to see if it still slips. If it does restart this procedure at step 1 A. If you have to do this procedure three times and it still slips call Cybex Customer Service. Follow the next step to be sure the belt is centered.

NOTE: Be careful not to over tighten the belt. Over tightening the belt can cause the belt to stretch and require replacement.

2. Center the belt.

NOTE: While centering the belt choose one bolt to adjust. Do not adjust both bolts.

- A.** With the treadmill running at 5 mph (8 kph) observe the running belt. If the belt tracks off center to the right or left the deck will become exposed. Use a 3/4" socket wrench to tighten the rear roller bolt on the side of the treadmill toward which the belt is moving. For example: If the belt moves to the right and the deck becomes exposed on the left, tighten the bolt on the right side of the frame, tighten about 1/2 of a turn (clockwise) and wait 30 seconds. If the belt does not move back to the center of the treadmill, make another adjustment to the same bolt. Once the running belt has been adjusted closer to the center of the treadmill use about 1/4 of a turn until the belt has been stabilized.
- B.** After the belt has been centered, check the belt tension again. Make sure the running belt tension is tight enough so that the belt does not slip or hesitate when stepped on. Walk on the treadmill at 3.5-4 mph (5.6-6.4 kph) and every 4th to 5th step throw your weight into your step to feel if the belt is slipping. If the belt does slip, use a wrench to equally tighten both rear roller adjustment bolts 1/2 of a turn (clockwise). Adjust the belt until no further slipping is felt.

Checking the Belt and Deck Surfaces — The running belt and deck should be checked periodically for any excessive wear. In an effort to make sure that the running belt operates properly, visually inspect the belt often to make sure that there are no tears or fraying in the belt material. The running belt, deck, deck bushings and motor brushes should be replaced every 9,000 miles (14,500 km). A service prompt will appear at this interval and the parts will need to be replaced.

Inspect the edges of the belt as described below.

Tools Required

- None

1. Disconnect the external power source.

- C.** Unplug the treadmill from the power outlet.

2. Check the belt and deck condition.

- A.** Look at the edges of the belt while you roll it by hand. If the belt has any rips or looks excessively worn the belt needs to be replaced.
- B.** Run your hand under the belt on the top of the deck surface. If you feel excessive ridges or cracks, or if any wood is exposed under the black surface, the deck should be replaced. In time, a worn belt and deck can cause high current draw and ultimately, motor failure.

NOTE: If the running belt and deck need replacement refer to a qualified service technician.

Other Preventive Maintenance

Other preventive maintenance activities must be completed by a qualified service technician at the recommended intervals listed in the Service Schedule at the end of this chapter. These activities include:

- Measure the motor brushes and replace worn motor brushes
- Replace the running deck and bushings
- Replace the running belt

Elevation Motor Lubrication - In time the elevation motor pivot points may develop a squeak. Lubricate the upper and lower bolts and the spacers with a small amount of lithium grease. **NOTE:** *You can buy lithium grease at an auto parts store.*

Static Electricity — Depending upon where you live, you may experience dry air, causing a common experience of static electricity. This may be especially true in the winter time. You may notice a static build-up just by walking across a carpet and then touching a metal object. The same can hold true while working out on your treadmill. You may experience a shock due to the build-up of static electricity on your body and the discharge path of the treadmill. If you experience this type of situation, you may want to increase the humidity to a comfortable level through the use of a humidifier.

Service Schedule

All maintenance activities shall be performed by qualified personnel. Failure to do so could result in serious injury.

NOTE: *This is the minimum recommended service.*

1. Determine mileage.

- A. While in *Dormant Mode* enter *Test Mode* by pressing and holding the **Heart Rate** and **Level** keys simultaneously for five seconds.
- B. Press the **Dist** key. DIST appears on the display. Record Mileage. **NOTE:** *Once the unit exceeds 999 miles or kilometers the odometer will use both screens. Example: 12,805 miles or km would be displayed as .*

NOTE: *To exit Test Mode, press the **Pause/Stop** key .*

First 500 miles (800 km).

- Check running belt tension and tracking.

Every 5,000 miles (8,000 km).

- Check running belt tension and tracking.
- Move treadmill and vacuum underneath.
- Raise elevation to 15%, Carefully tip treadmill up on the console to clean underneath with a dry cloth and vacuum. Return to normal position when done.

Every 9,000 miles (14,500 km).

- Replace running belt and deck.
- Replace deck bumpers.
- Replace drive motor brushes.
- Check elevation assembly and replace worn parts.
- Lubricate elevation pivot points.

NOTE: *Every 9,000 miles (14,500 km) the unit will show “SVC” on the display. The unit will then emit a short beep every 2 minutes. This will continue until the service is performed and the service odometer is reset.*

2. Resetting the service odometer.

- A.** While in *Dormant Mode* enter *Test Mode* by pressing and holding the **Heart Rate** and **Level** keys simultaneously for five seconds.
- B.** Press the **Cool Down** key to display "**SVC**" and miles or kilometers on service odometer.
- C.** Press the **Λ** or **V** key to display "**RST**".
- D.** Press the **Enter** key to reset the service odometer to zero.

NOTE: *Service may be performed before the 9,000 miles (14,500 km) service prompt appears. Perform the service on the unit and follow the above procedure to reset the service odometer.*

This page intentionally left blank

5 - Customer Service

Contacting Service

Hours of phone service are Monday through Friday from 8:30 a.m. to 6:00 p.m. Eastern Standard Time.

For Cybox customers living in the USA, contact Cybox Customer Service at **888-462-9239**.

For Cybox customers living outside the USA, contact Cybox Customer Service at **508-533-4300** or fax **508-533-5183**.

Serial Number and Voltage

Your serial number and voltage can be found on the rear of your treadmill. See Figure 1. For your convenience record your serial number and voltage below so that you will have it ready if you call Cybox Customer Service.

Serial Number _____ Voltage _____

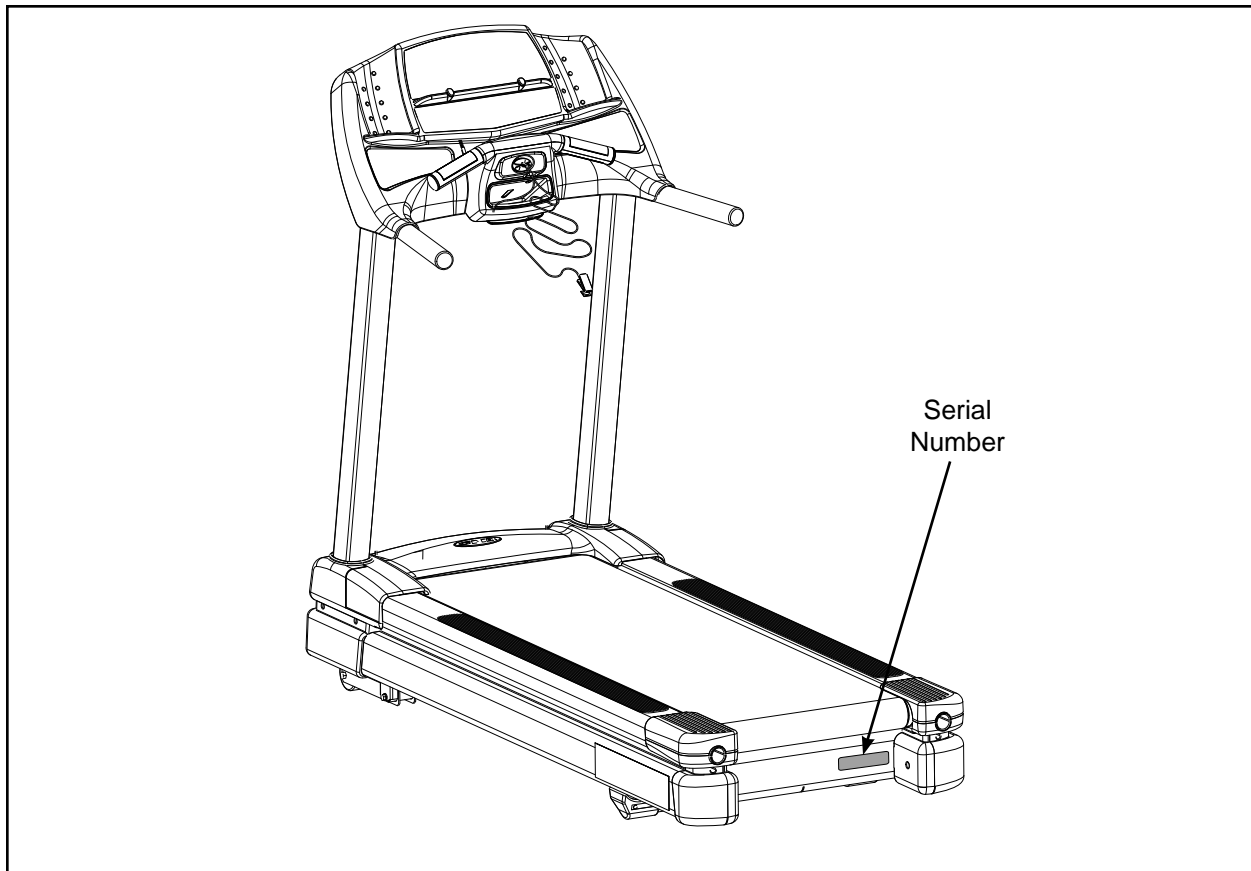

Figure 1

Return Material Authorization (RMA)

The Return Material Authorization (RMA) system outlines the procedures to follow when returning material for replacement, repair, or credit. The system assures that returned materials are properly handled and analyzed. Follow the following procedures carefully.

Contact your authorized Cybex dealer on all warranty-related matters. Your local Cybex dealer will request an RMA from Cybex, if applicable. Under no circumstances will defective parts or equipment be accepted by Cybex without proper RMA and an Automated Return Service (ARS) label.

1. Call the Customer Service Hotline listed above for the return of any item that is defective.
2. Provide the technician with a detailed description of the problem you are having or the defect in the item you wish to return.
3. Provide the model and serial number of your treadmill. The serial number is located on the front panel of your treadmill. The serial number begins with a letter, for example: R09-101331100.
4. At Cybex's discretion, the technician may request that you return the problem part(s) to Cybex for evaluation and repair or replacement. The technician will assign you an RMA number and will send you an ARS label. The ARS label and RMA number must be clearly displayed on the outside of the package that contains the item(s) to be returned. Include a description of the problem, the serial number of the treadmill and the name and address of the owner in the package along with the part(s).
5. Forward the package through UPS to Cybex.
Attn: Customer Service Department
Cybex International, Inc.,
10 Trotter Drive
Medway, MA 02053

NOTE: *Merchandise returned without an RMA number on the outside of the package or shipments sent C.O.D. will not be accepted by the Cybex receiving department.*

Damaged Parts

Materials damaged in shipment should not be returned for credit. Shipping damages are the responsibility of the carrier (UPS, Federal Express, trucking companies, etc.)

Apparent Damage - Upon receipt of your shipment, check all boxes carefully. Any damage seen with a visual check must be noted on the freight bill and signed by the carrier's agent. Failure to do so will result in the carrier's refusal to honor your damage claim. The carrier will provide you with the required forms for filing such claims.

Concealed Damage - Damage not seen with a visual check upon receipt of a shipment but noticed later must be reported to the carrier as soon as possible. Upon discovery of the damage, a written or phone request to the carrier asking them to perform an inspection of the materials must be made within ten days of the date of delivery. Keep all shipping containers and packing materials: they will be needed as part of the inspection process. The carrier will provide you with an inspection report and the necessary forms for filing a concealed damage claim. Concealed damage is the carrier's responsibility.

Ordering Parts

Fax your order to **508-533-5183**. To speak with a customer service representative, call **888-462-9239** (for customers living within the USA) or **508-533-4300** (for customers outside the USA).



CAUTION

**Use only Cybex replacement parts when servicing.
Failure to do so could result in personal injury.**

Cybex will void warranty if non-Cybex replacement parts are used.

This page intentionally left blank

Appendix A - Technical Specifications

Specifications

| | |
|----------------------|--|
| Length: | 72" (183 cm) |
| Width: | 32" (82 cm) |
| Running Area: | 20" x 60" (51 cm x 152 cm) |
| Weight of Product: | 320 lbs. (145 kg) |
| Shipping Weight | 350 lbs. (159 kg) |
| Speed Range: | 0.5 to 11.0 mph (0.8 to 17.6 kph) in 0.1 mph or 0.1 kph increments |
| Incline Range: | 0 to 15% grade |
| Manual Mode: | Yes |
| Programs: | Quick Start plus Manual, HR Control, Speed Interval 1, Speed Interval 2, Hill Interval, Pikes Peak, Rolling Hills, Hills, Weight Loss and Cardio |
| Standard Features: | Contact Heart Rate, Polar® wireless heart rate (chest strap not included), CSAFE, frame color choices include white texture, black texture, metaltone gold, black chrome and platinum sparkle |
| Optional Features: | Unlimited custom colors available |
| Power Requirement: | Grounded, dedicated circuit and one of the following: <ul style="list-style-type: none">• 115 VAC \pm5, 60 Hz and 15 amps• 208/220 VAC, 60 Hz 10 amps• 230 VAC \pm5, 50 Hz and 10 amps |
| Motor: | 3.0 hp, DC. continuous duty |
| Emergency Stop: | Pull the emergency stop key (lanyard) |
| Maximum User Weight: | 350 lbs. (158 kg) |

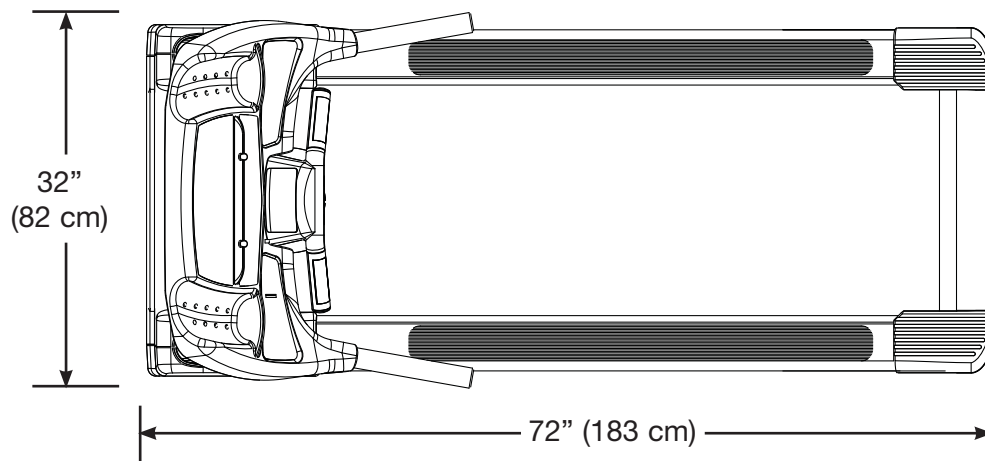

This page intentionally left blank

Appendix B - Program Overview

Manual

Program Overview

Manual Mode is available both through **Quick Start** and through the **Manual** program where you are prompted to enter **Time** and **Weight**. **NOTE:** *There is no diagram because incline and speed are user-controlled.*

Manual Mode allows you to choose settings as you workout. You may choose your settings according to how you feel or your endurance level. Since you remain in control, *Manual Mode* may be the best choice for beginners or for those who have not worked out in a long time. **NOTE:** *Manual Mode is not a preprogrammed workout.*

Press the **Quick Start** key to workout in *Manual Mode*. You can also begin *Manual Mode* by pressing the Manual program key. To increase or decrease the speed while in *Manual Mode* use the **Speed +** — keys. To increase or decrease the incline while in *Manual Mode* use the **Incline ▲ ▼** arrows.

Speed Interval 1 (P-1)

Program Overview

This program is designed to introduce an individual to incorporating running into their training. The program uses exclusively 0% incline with a repeating 1:2 work to rest ratio. Each work segment lasts 30 seconds and each rest segment lasts 60 seconds. The speeds during the rest segments are at a walking pace while the speeds in the work segments are approximately double the rest speed. See Figure 1.

| | Base Speed mph | / Base Elevation % grade | Peak Speed mph | / Peak Elevation % grade |
|---------|---------------------------------|---|---------------------------------|---|
| Level 1 | 3.2 | 0% | 6.5 | 0% |
| 2 | 3.4 | 0% | 7.0 | 0% |
| 3 | 3.6 | 0% | 7.5 | 0% |
| 4 | 4.8 | 0% | 8.0 | 0% |
| 5 | 4.0 | 0% | 8.5 | 0% |
| 6 | 4.2 | 0% | 9.0 | 0% |
| 7 | 4.4 | 0% | 9.5 | 0% |
| 8 | 4.6 | 0% | 10.0 | 0% |
| 9 | 4.8 | 0% | 10.5 | 0% |
| 10 | 5.0 | 0% | 11.0 | 0% |

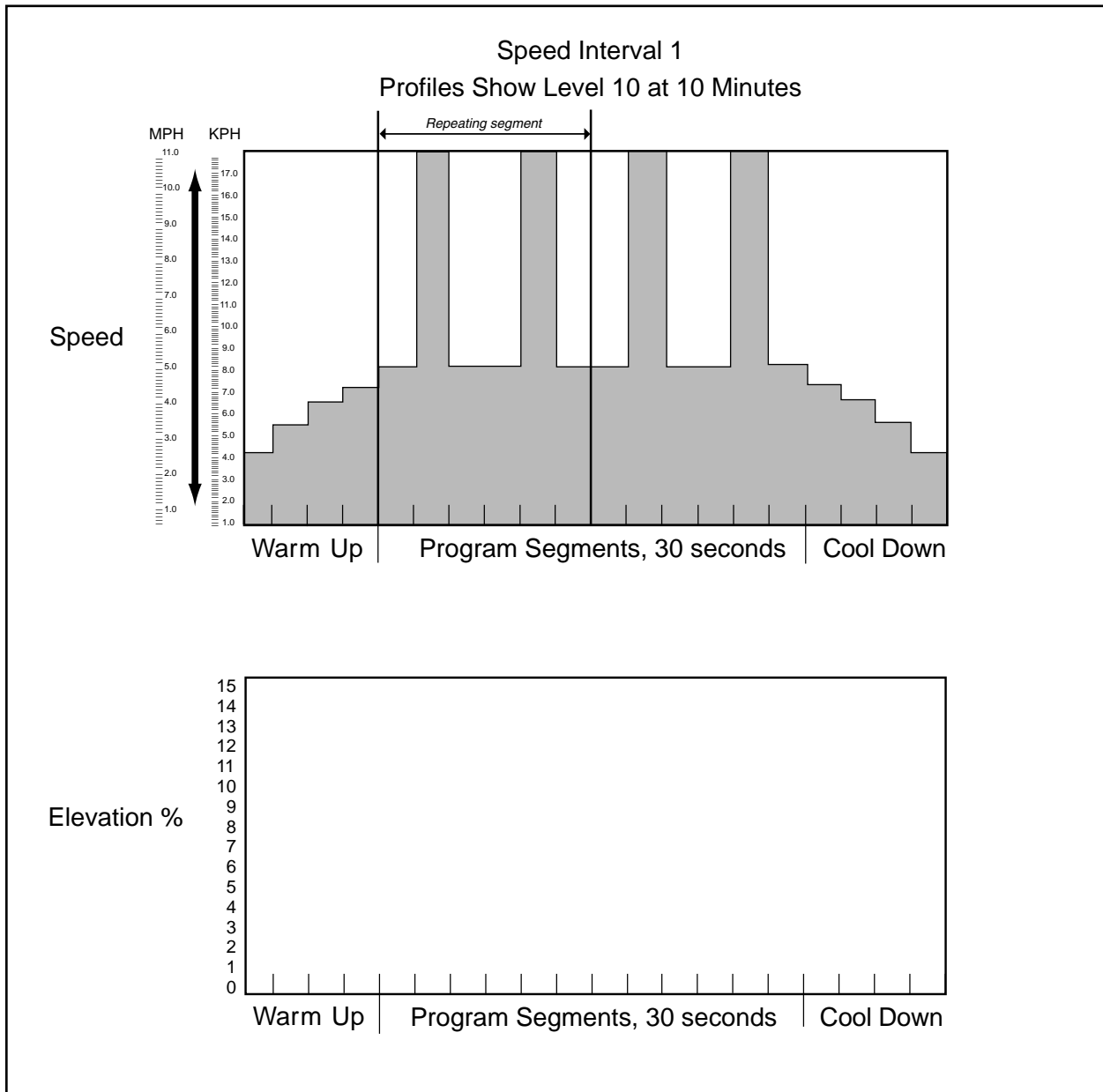

Figure 1

Speed Interval 2 (P-2)

Program Overview

This program is designed for those wishing to introduce speed into their training. The program uses exclusively 0% incline with a repeating 1:3 work to rest ratio. Each work segment lasts 15 seconds and each rest segment lasts 45 seconds. The speeds during the rest segments are at a walking pace while the speeds in the work segments are approximately triple the rest speed. See table below and Figure 2.

| | Base Speed mph | / Base Elevation % grade | Peak Speed mph | / Peak Elevation % grade |
|---------|---------------------------|-------------------------------------|---------------------------|-------------------------------------|
| Level 1 | 2.2 | 0% | 6.5 | 0% |
| 2 | 2.4 | 0% | 7.0 | 0% |
| 3 | 2.6 | 0% | 7.5 | 0% |
| 4 | 2.8 | 0% | 8.0 | 0% |
| 5 | 3.0 | 0% | 8.5 | 0% |
| 6 | 3.2 | 0% | 9.0 | 0% |
| 7 | 3.4 | 0% | 9.5 | 0% |
| 8 | 3.6 | 0% | 10.0 | 0% |
| 9 | 3.8 | 0% | 10.5 | 0% |
| 10 | 4.0 | 0% | 11.0 | 0% |

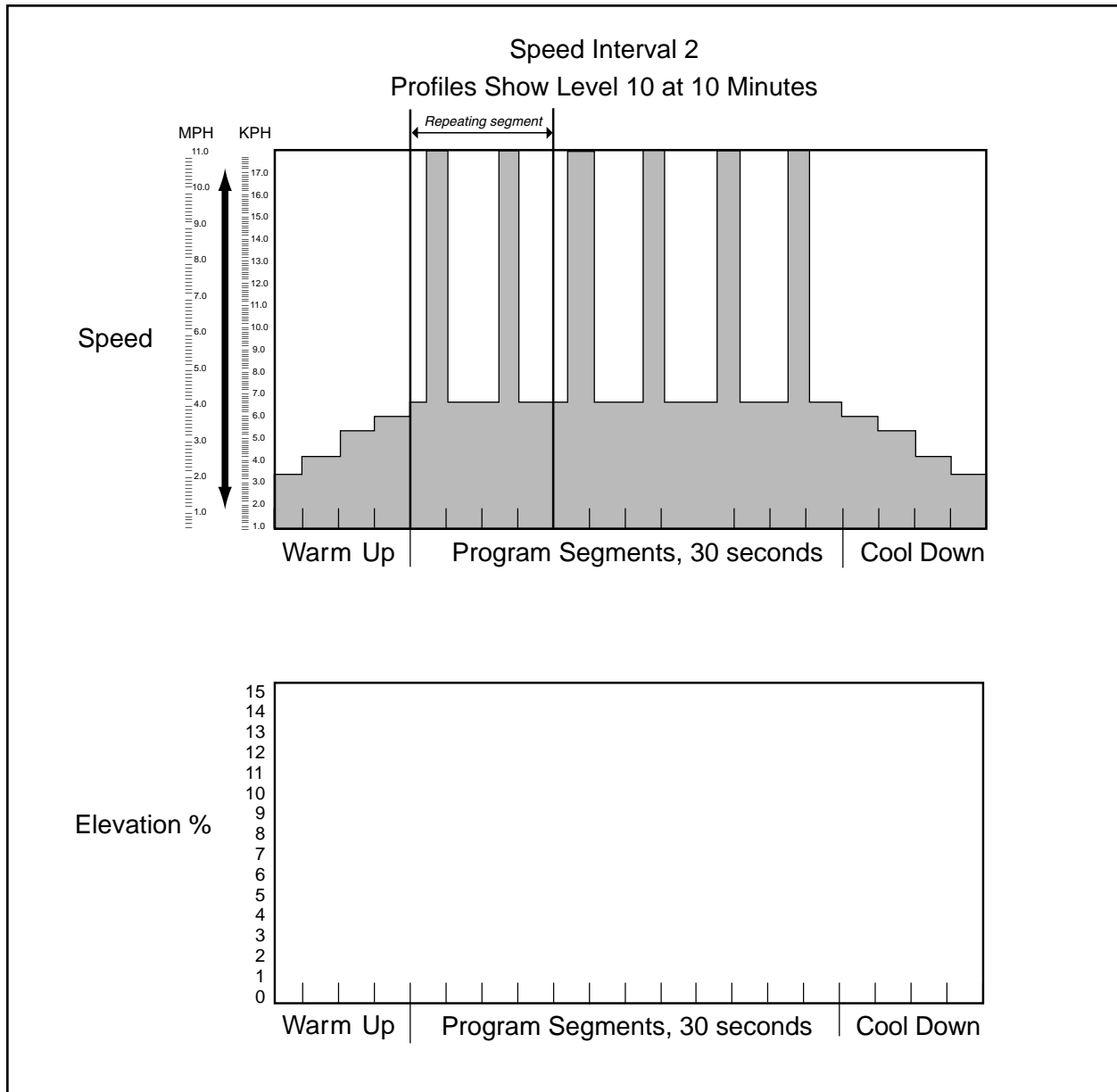

Figure 2

Hill Interval (P-3)

Program Overview

This program is designed to introduce some variability into the program while maintaining a constant walking pace. The Hill Interval program varies the incline between two levels every 60 seconds. This provides for moderate variation that elicits an improved result over steady state walking up an incline. See table below and Figure 3.

| | Base Speed mph | / Base Elevation % grade | Peak Speed mph | / Peak Elevation % grade |
|---------|---------------------------|-------------------------------------|---------------------------|-------------------------------------|
| Level 1 | 1.7 | 1% | 1.7 | 6% |
| 2 | 2.0 | 2% | 2.0 | 7% |
| 3 | 2.3 | 3% | 2.3 | 8% |
| 4 | 2.6 | 3% | 2.6 | 9% |
| 5 | 2.9 | 4% | 2.9 | 10% |
| 6 | 3.2 | 5% | 3.2 | 11% |
| 7 | 3.5 | 5% | 3.5 | 12% |
| 8 | 3.8 | 6% | 3.8 | 13% |
| 9 | 4.1 | 7% | 4.1 | 14% |
| 10 | 4.4 | 6% | 4.4 | 15% |

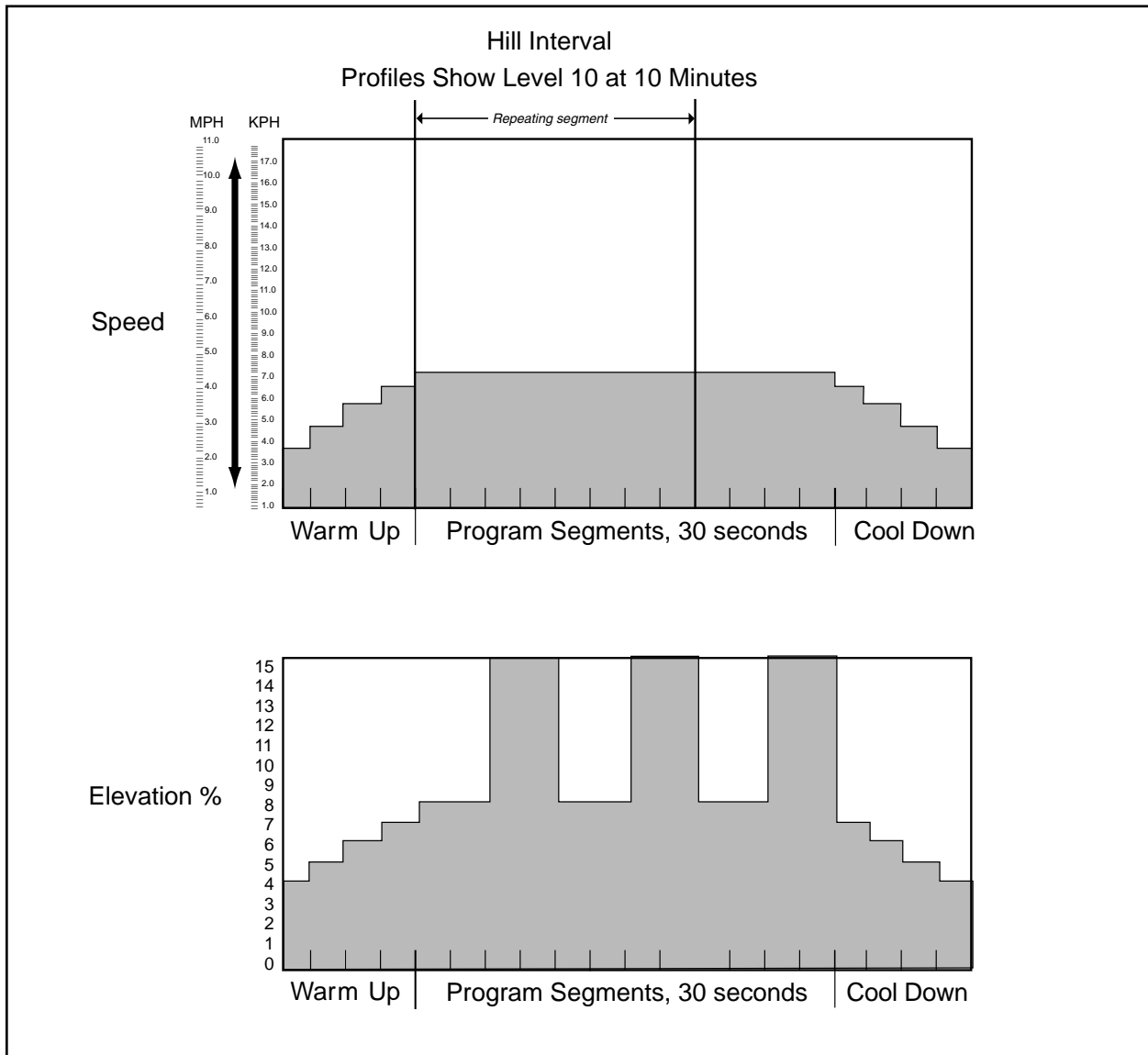

Figure 3

Pikes Peak (P-4)

Program Overview

Pikes Peak uses a nine-minute core where the incline increases every minute for the first five minutes. As the incline increases, speed is slightly reduced in the same fashion as it would if one were hiking up an ever steeper hill. After the fifth minute of the core program, the incline is reduced each minute and the speed increases. All speeds in this program are at a walking pace. See table below and Figure 4.

| | Base Speed mph | / Base Elevation % grade | Peak Speed mph | / Peak Elevation % grade |
|---------|---------------------------|-------------------------------------|---------------------------|-------------------------------------|
| Level 1 | 2.2 | 1% | 3.0 | 6% |
| 2 | 2.4 | 2% | 3.2 | 7% |
| 3 | 2.6 | 3% | 3.4 | 8% |
| 4 | 2.8 | 3% | 3.6 | 9% |
| 5 | 3.0 | 4% | 3.8 | 10% |
| 6 | 3.2 | 5% | 4.0 | 11% |
| 7 | 3.4 | 5% | 4.2 | 12% |
| 8 | 3.6 | 6% | 4.4 | 13% |
| 9 | 3.8 | 7% | 4.6 | 14% |
| 10 | 4.0 | 8% | 4.8 | 15% |

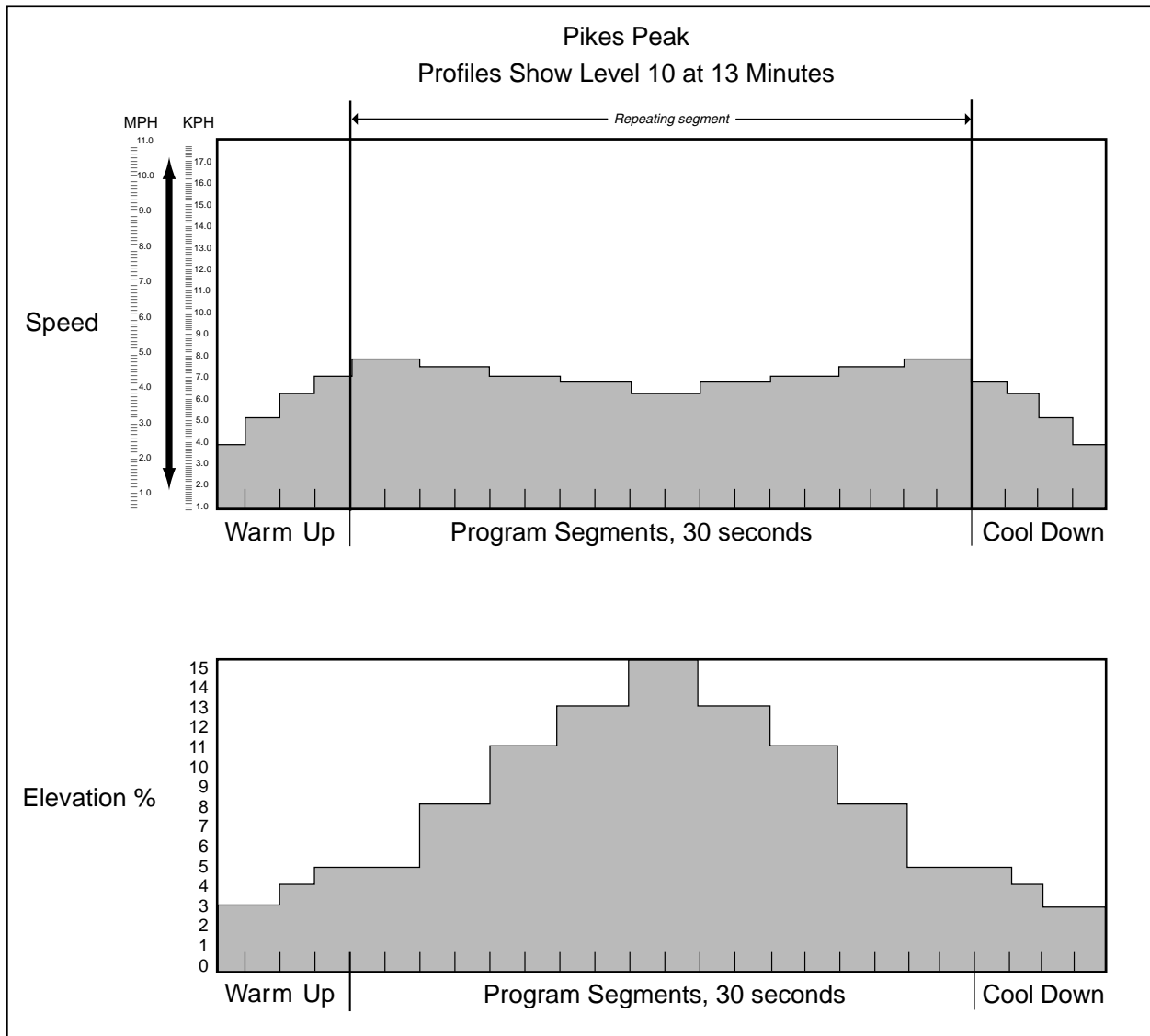

Figure 4

Rolling Hills (P5)

Program Overview

The Rolling Hills program uses a four-minute core. In the core program each minute represents a segment. Segments two and four are the "rest" intervals and use the same speed. The first and third segments also use higher speeds than the rest intervals with the first segment having the least incline and the third having the greatest. This provides for the following relative work pattern: work – rest – work harder - rest - and then repeat. See table below and Figure 5.

| | Base Speed mph | / Base Elevation % grade | Peak Speed mph | / Peak Elevation % grade |
|---------|---------------------------------|---|---------------------------------|---|
| Level 1 | 1.5 | 0% | 3.5 | 5% |
| 2 | 2.0 | 0% | 4.0 | 6% |
| 3 | 2.5 | 0% | 4.5 | 6% |
| 4 | 3.0 | 1% | 5.0 | 6% |
| 5 | 3.5 | 1% | 5.5 | 7% |
| 6 | 4.0 | 2% | 6.0 | 7% |
| 7 | 4.5 | 2% | 6.5 | 7% |
| 8 | 5.0 | 3% | 7.0 | 8% |
| 9 | 5.5 | 3% | 7.5 | 8% |
| 10 | 6.0 | 4% | 8.0 | 8% |

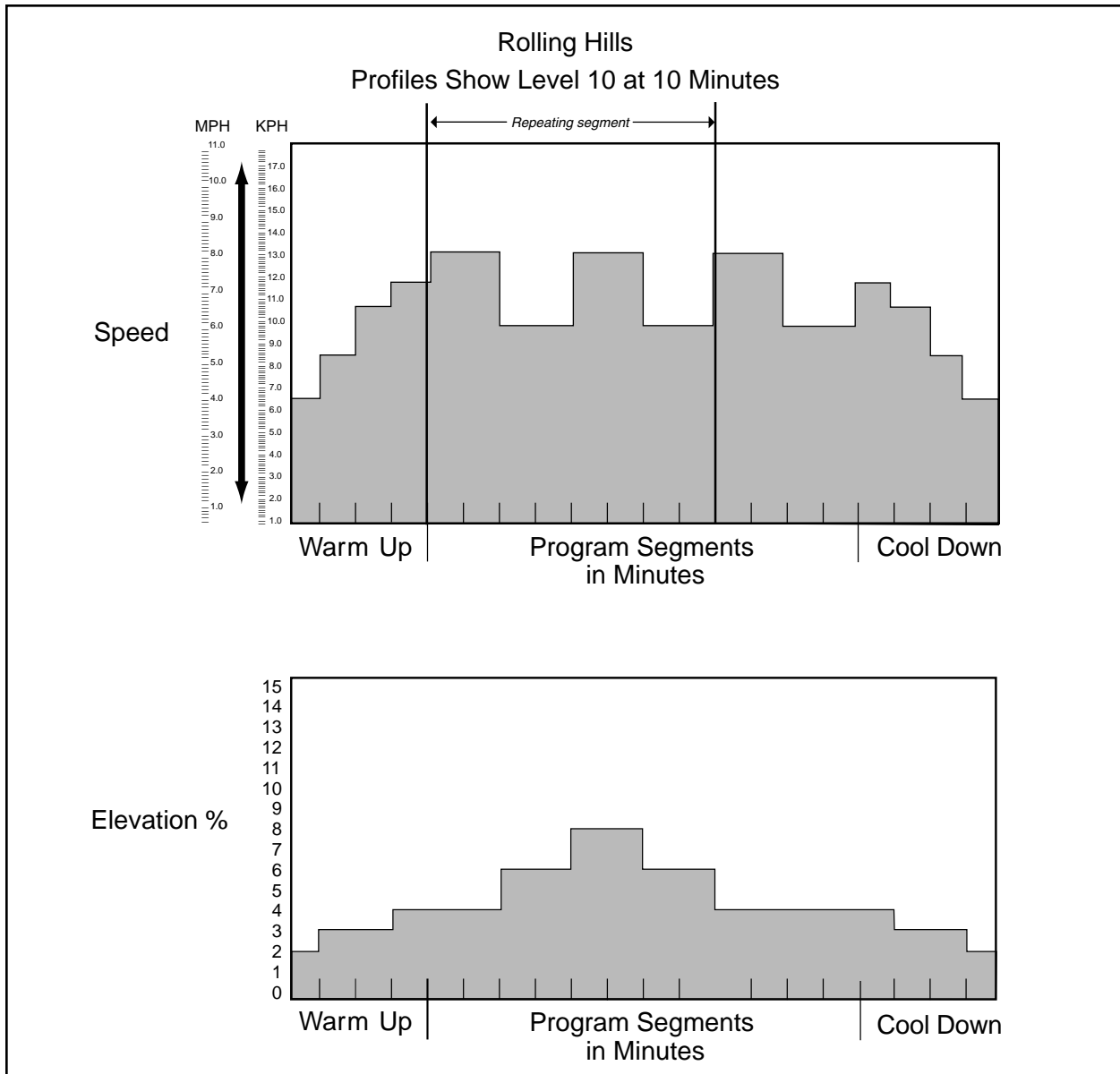

Figure 5

Hills (P-6)

Program Overview

The Hills program is a constant speed walking program that introduces incline that varies each minute for a series of relative peaks and valleys. See table below and Figure 6.

| | Base Speed mph | / Base Elevation % grade | Peak Speed mph | / Peak Elevation % grade |
|---------|---------------------------------|---|---------------------------------|---|
| Level 1 | 2.2 | 0% | 2.2 | 6% |
| 2 | 2.4 | 0% | 2.4 | 7% |
| 3 | 2.6 | 1% | 2.6 | 8% |
| 4 | 2.8 | 2% | 2.8 | 9% |
| 5 | 3.0 | 3% | 3.0 | 10% |
| 6 | 3.2 | 4% | 3.2 | 11% |
| 7 | 3.4 | 5% | 3.4 | 12% |
| 8 | 3.6 | 6% | 3.6 | 13% |
| 9 | 3.8 | 7% | 3.8 | 14% |
| 10 | 4.0 | 8% | 4.0 | 15% |

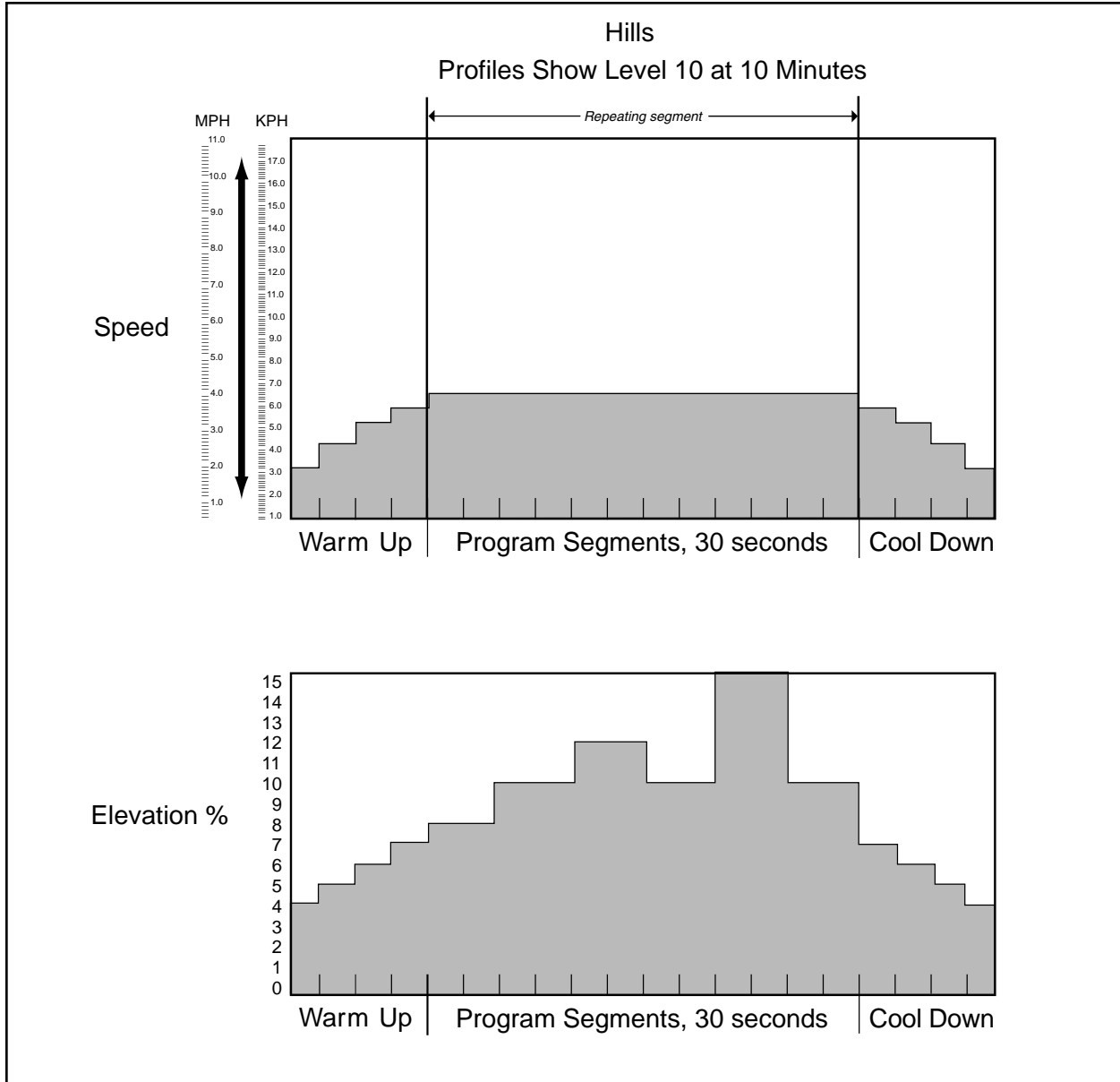

Figure 6

Weight Loss (P-7)

Program Overview

This program was designed to help individuals of all fitness levels achieve their weight loss goals through a protocol that incorporates both low and moderate intensity activity. Because walking has become a popular mode of exercise for those looking to lose weight, all levels of this program are performed at walking speeds.

The core of the program is made up of five one-minute segments. The first segment represents the baseline of the program and may also be considered to be a “rest” segment later. In minutes two and three, elevation will be increased. In minute four, the program returns to the first segment baseline or rest level. In the fifth minute, the speed will increase. The total number of segments used is dictated by the time selected by the user.

Higher levels of the Weight Loss program incorporate jogging speeds in short segments. This allows the advanced walker to alternate walking and jogging.

- At levels 1-6 walkers maintain walking speeds only.
- At levels 7-10, experienced walkers can jog intermittently.

By mixing the use of speed and elevation separately, the user receives the benefits of added intensity intervals but the variety does not allow for either speed or elevation to dominate and therefore overtax the user. See table below and Figure 7.

| Level | Base Speed mph | Uphill Elevation % Grade | Increased Speed mph |
|-------|-------------------|-----------------------------|------------------------|
| 1 | 3.4 WALK | 2% | 3.5 WALK |
| 2 | 3.4 | 3% | 3.5 |
| 3 | 3.7 | 4% | 3.8 |
| 4 | 3.7 | 6% | 3.8 |
| 5 | 3.8 | 4% | 4.0 |
| 6 | 3.8 | 6% | 4.0 |
| 7 | 4.0 | 6% | 4.5 WALK-JOG |
| 8 | 4.0 | 8% | 5.0 |
| 9 | 4.2 | 8% | 5.5 |
| 10 | 4.2 | 10% | 6.0 |

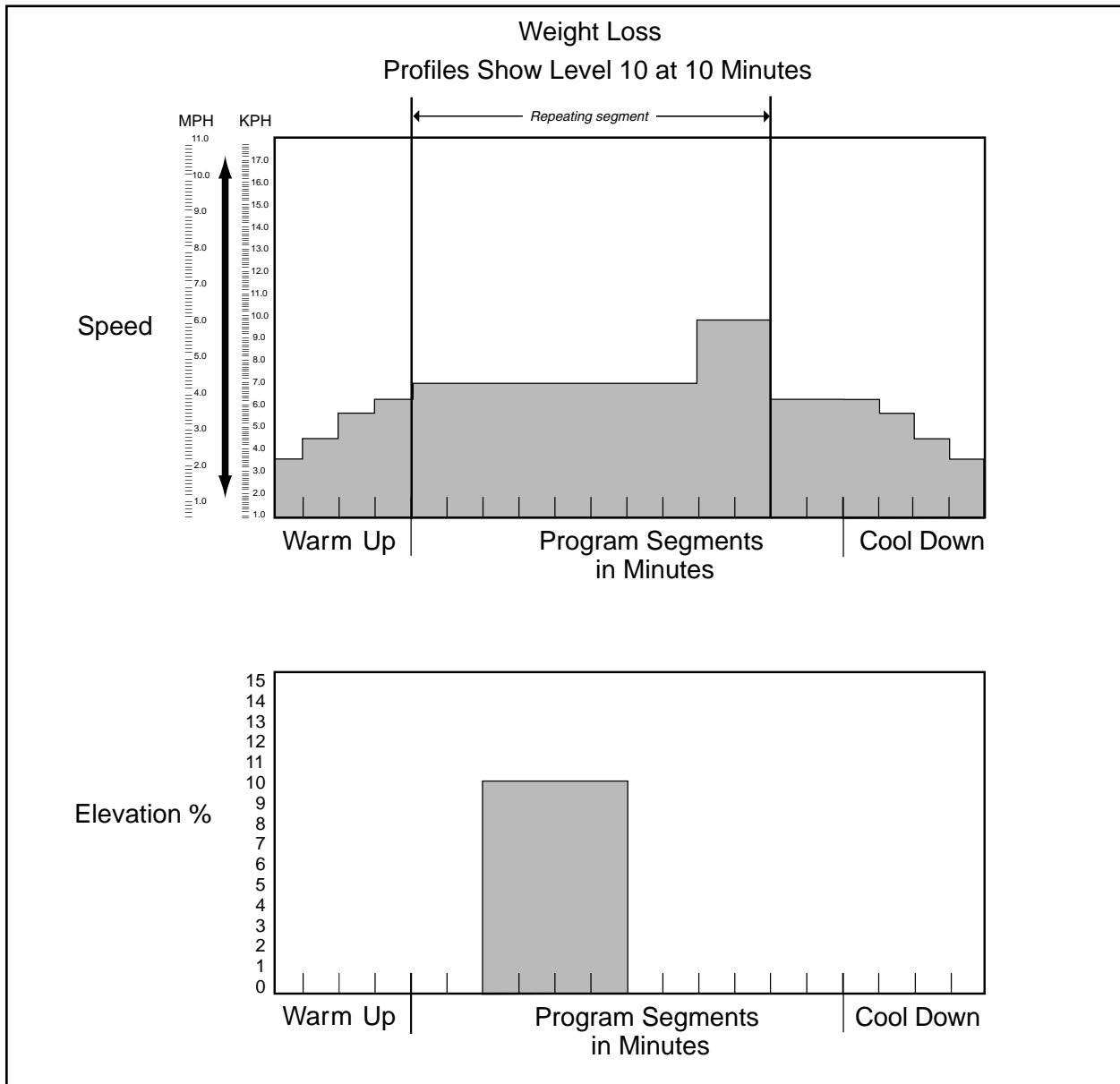

Figure 7

Cardio (P-8)

Program Overview

This program was designed for the exercise participant who wants to improve the overall efficiency of their cardio-respiratory system. Unlike some of the other treadmill programs that incorporate low and moderate intensity segments, the Cardio program contains overall higher intensity levels with more moderate recovery segments.

The speed range of the program includes walking speeds at the lower levels up through a moderate jog in the higher levels.

Elevation is used to emphasize the high intensity portion of this program while decreased elevation and a small increase in speed mark the recovery segment. High intensity and recovery segments are always in a one-to-one time based ratio and make up the core eight minutes of the program. See table below and Figure 8.

| | Base Speed mph | / Peak Elevation % grade | Base Speed mph | / Peak Elevation % grade |
|---------|---------------------------|-------------------------------------|---------------------------|-------------------------------------|
| Level 1 | 3.2 | 2% | 3.5 | 0% |
| 2 | 3.5 | 3% | 3.8 | 0% |
| 3 | 3.8 | 4% | 4.0 | 0% |
| 4 | 4.0 | 5% | 4.2 | 0% |
| 5 | 4.2 | 5% | 5.0 | 2% |
| 6 | 5.0 | 5% | 5.5 | 2% |
| 7 | 5.5 | 5% | 5.8 | 2% |
| 8 | 6.0 | 6% | 6.2 | 2% |
| 9 | 6.2 | 6% | 6.5 | 2% |
| 10 | 6.5 | 6% | 6.8 | 2% |

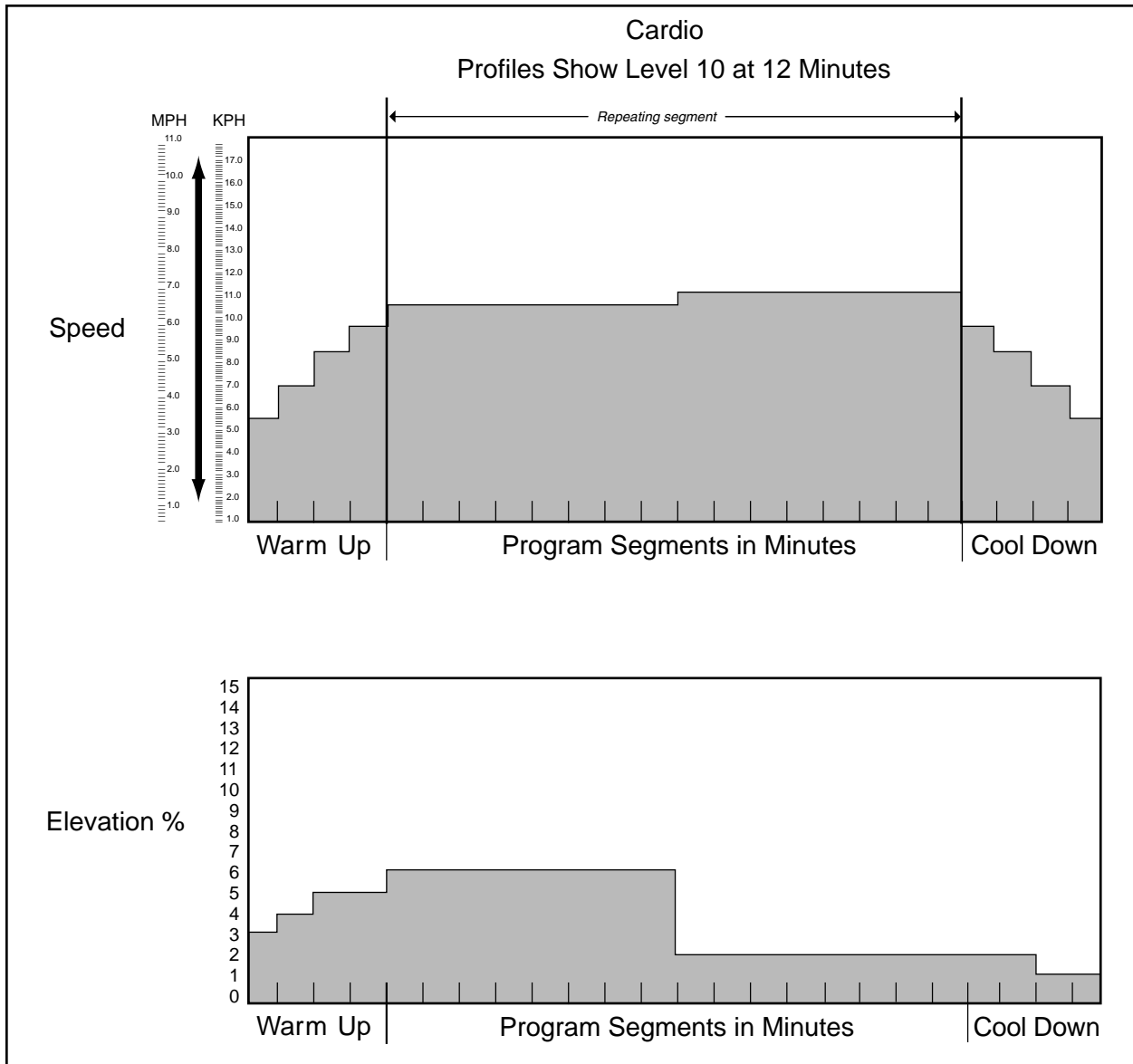

Figure 8

This page intentionally left blank

Cybex 425T Treadmill Owner's Manual

Parts List

| ITEM NO. | QTY. | PART NO. | DESCRIPTION |
|----------|------|-----------|---|
| 1 | 1 | AF-18899 | Weldment, Console Back Plate |
| 2 | 1 | AL-18596 | Front Roller, 2.75 O.D. |
| 3 | 1 | AL-18597 | Rear Roller, 2.75 O.D. |
| 6 | 1 | SK-17827 | Assembly, Contact Grip, Pair |
| 7 | 1 | AF-18394 | Weldment, Elevation |
| 8 | 1 | AX-18729 | Assembly, Idler |
| 9 | 1 | AX-20944 | Assembly, E-Stop Lanyard |
| 10 | 1 | AX-19239 | Assembly, Motor Cover |
| 11 | 1 | BD-18763 | Belt, Running |
| 12 | 1 | BD-18917 | Belt, Poly-V,320J8 |
| 15 | 2 | DE-19360 | Decal, Side Labels, Black |
| 15 | 2 | DE-19353 | Decal, Side Labels, Silver |
| 17 | 1 | DK-18401 | Deck, Running |
| 18 | 1 | KAX-21507 | Sensor, Speed |
| 19 | 1 | EH-00986 | Wire Tie, 9" |
| 20 | 1 | EH-10291 | Base, Wire Tie |
| 21 | 1 | FM-18405 | Shaft, Elevation |
| 22 | 4 | FS-16511 | Plate, Rear Rubber Foot Mounting |
| 23 | 1 | FS-19213 | Cable, Connector Plate, 425T |
| 24 | 1 | FT-16825 | Sleeve, Elevation Mounting, Top |
| 25 | 1 | FT-16826 | Sleeve, Elevation Mounting, Bottom |
| 26 | 2 | HB-16367 | Bushing, .50 I.D. x .62 O.D. x .31 LG, Flanged |
| 27 | 2 | HN-10029 | Nut, 1/2 - 13 HEX STL ZINC |
| 28 | 2 | HN-17935 | Nut Locking, 3/8 - 24, GRD C, STL, ZN |
| 29 | 2 | HS-00156 | Screw, 4-40 x .62, PNHD PHIL |
| 30 | 2 | HS-00261 | Bolt, 1/2 - 13 x 5.5, HXHD |
| 31 | 10 | HS-15706 | Screw, 8-16 x .50, PNHD, STL, BLK ZN CLR, TYP WB |
| 32 | 10 | HS-16509 | Screw, SLFTP, 10 x .5, PNHD, PLT, TYP B, PT-S |
| 33 | 10 | HS-16628 | Bolt, 1/4 - 20 x 1.5, HXHD, G8 |
| 34 | 6 | HS-16929 | Bolt, Whiz Lock, 3/8 - 16 x .625, HXHD, G5 |
| 35 | 8 | HS-16939 | Screw, SEMS,10/32 x .75, PNHD, BLK ZN, EXT |
| 36 | 1 | HS-17936 | Bolt, 3/8 - 24 x 2.0, HXHD CAP, G8, YEL ZN |
| 37 | 1 | HS-17937 | Bolt, 3/8 - 24 x 2.75, HXHD CAP, G8, YEL ZN |
| 38 | 4 | HS-19108 | Screw 5/16-18 x 3/4, HXHD, Whiz-Lock |
| 39 | 1 | HS-41006 | Screw, SLFTP, 10/24 x 1.38, PNHD PHIL, SST, BLK, TT |
| 40 | 2 | HS-41107 | Bolt, 5/16 - 18 x 1.5, BTHD, SST, BLK |
| 41 | 2 | HW-00165 | Washer, Split Lock, 5/16, ZINC |
| 42 | 8 | HW-00180 | Washer, Split Lock, 1/4, SST, BLK |
| 43 | 2 | HW-00590 | Bushing, Nylon, 1/2 |
| 44 | 12 | HW-18123 | Washer, .344 I.D. x .75 O.D. x .125 Thick, Black Zinc |
| 45 | 2 | HX-13771 | Ring, Retaining, 5/8 x .579 FR. I.D. |
| 46 | 2 | HX-19981 | Bushing, Deck, 5/16 - 18 |
| 47 | 1 | HX-20799 | Plug, Plastic, 9/16", BLACK |
| 48 | 4 | HX-17788 | Tape, Double Sided, .032 Thick |
| 49 | 1 | HX-19529 | E-Ring, Retaining, 5555-37 |
| 50 | 2 | HX-18901 | Grips, 425 Upright Handrail |
| 51 | 1 | HX-19052 | Idler Spring |
| 52 | 2 | HX-19102 | Rubber Foot, Rear |
| 53 | 1 | HX-19384 | Coupling, Shaft, DBL Split 5/8 |
| 56 | 1 | PL-18773 | Plunger, E-Stop |
| 57 | 1 | PL-18929 | Cover, Rear, Outer Right |
| 58 | 1 | PL-18930 | Cover, Rear, Inner Right |
| 59 | 1 | PL-18932 | Cover, Rear, Outer Left |
| 60 | 1 | PL-18933 | Cover, Rear, Inner Left |
| 61 | 1 | PL-18990 | Cover, Motor, Front, 425T |
| 62 | 1 | PL-18991 | Cover, Motor, Right ,425T |
| 63 | 1 | PL-18992 | Cover, Motor Left,425T |
| 64 | 1 | PL-19061 | Cover, Console, Back Trim, 425T |
| 65 | 1 | PL-19093 | Cover, Handle Lower |
| 66 | 1 | PL-19094 | Accessory Tray, 425T Console |
| 68 | 1 | SW-18535 | Switch, Limit |
| 70 | 8 | HS-11977 | Screw, SEMS, 8/32 x .38, PNHD |
| 73 | 2 | HX-22247 | Busing, Spanner,.500 OD X 1.5"L |
| 74 | 2 | CW-22240 | Wheel, 80mm Dia X 32mm |

Cybex 425T Treadmill Owner's Manual

| ITEM NO. | QTY. | PART NO. | DESCRIPTION |
|----------|------|-------------|---|
| 75 | 4 | HB-18768 | Bearing, LF-1011-12 |
| 76 | 2 | HS-60022 | Bolt, 3/8 x 2.25, HXHD CAP, Black Zinc, G5 |
| 77 | 2 | HN-60064 | Nut, Jam 3/8 - 16, Black Zinc |
| 78 | 1 | AF-18481 | Weldment, Motor Base |
| 79 | 1 | AF-18769 | Bracket, Heat Sink |
| 80 | 2 | HB-18768 | Bearing, LF-1011-12 |
| 81 | 1 | AD-18213 | PCA, Control Board,115 VAC |
| 81 | 1 | AD-18217 | PCA, Control Board, 230 VAC |
| 82 | 2 | EC-18538 | Circuit Breaker, 15 Amp, 115 VAC |
| 82 | 2 | EC-18539 | Circuit Breaker, 10 Amp, 250 VAC |
| 83 | 1 | EC-18896 | Filter, 16 Amp |
| 84 | 4 | HN-11136 | KEPS, 5/16 - 18, HEX STL ZINC |
| 86 | 8 | EH-00986 | Wire Tie, Nylon, 9 |
| 87 | 2 | HN-11925 | KEPS, 10-32, HEX STL ZN |
| 88 | 1 | HW-10856 | Washer, Lock External, No. 10 ZC |
| 89 | 2 | HS-15732 | Screw, SEMS, 8-32 UNC x .62, PNHD PHIL, ZN |
| 90 | 1 | EH-12260 | Wire Tie, Nylon, 18 |
| 91 | 1 | FS-19355 | Plate, Circuit Breaker Mount |
| 92 | 1 | DE-16928 | Label, Disconnect Power, Multilingual |
| 93 | 1 | DE-19238 | Decal, Warning, Motor Plate |
| 94 | 1 | DE-19198 | Decal, Cybex |
| 95 | 1 | AF-18728 | Bracket, Idler |
| 96 | 1 | HB-19135 | Idler Wheel, 1.88 x 1.0 |
| 97 | 2 | HB-18056 | Bushing, Flange, .375 x .469 x .25 |
| 98 | 1 | HS-19338 | Screw, 3/8 - 16 x 1.75, SCHD BTN, BLK, ZN |
| 102 | 1 | MR-18402 | Motor, Elevation, 115 VAC |
| 102 | 1 | MR-18403 | Motor, Elevation, 230 VAC |
| 103 | 1 | MR-19643 | Motor, Drive, 115 VAC |
| 103 | 1 | AX-19650 | Motor, Drive, 230 VAC |
| 104 | 1 | DE-20685 | Decal, E-stop, Yellow |
| 120 | 1 | EH-19416 | Heat Sink, Silpad |
| 121 | 1 | EC-15004 | Ferrite, Clamp-on, .40 I.D. |
| 200 | 1 | SCK-18765 | Assembly, Top Platform, Right |
| 201 | 1 | SCK-18764 | Assembly, Top Platform, Left |
| 202 | 1 | SCK-18486 | Weldment, Upright |
| 203 | 1 | AF-18461 | Weldment, Frame, 425T |
| 204 | 1 | DE-18766 | Decal, Safety Walk |
| 205 | 8 | HS-18311 | Screw, 8-16 x .75", PNHD, STL, BLK ZN CLR, TYP WB |
| 206 | 1 | PL-18931 | Cover, Rear, Top Left |
| 207 | 1 | PL-19120 | Cover, Rear, Bottom Left |
| 208 | 1 | PL-18928 | Cover, Rear, Top Right |
| 209 | 1 | PL-19118 | Cover, Rear, Bottom Right |
| 210 | 1 | DE-19441 | Decal, 425T, Black |
| 210 | 1 | DE-19442 | Decal, 425T, Silver 877 |
| 211 | 1 | HX-18287 | Plug, Hole, Plastic, 1", Black |
| 220 | 1 | FM-19513 | Shaft, Deck Pivot |
| 221 | 2 | AX-20035 | Assembly, Deck Pivot Bracket |
| 222 | 2 | DE-22327 | LABEL,BLACK,INTELLIGENT SUSPENSION 3 |
| 223 | 2 | DE-22328 | LABEL,SILVER,INTELLIGENT SUSPENSION 3 |
| 300 | 1 | AX-18545-X* | Assembly, 425T Console* |
| 301 | 1 | AX-19356-X* | Assembly, Cover, Top CHR* |
| 304 | 1 | AD-21467 | PCA, Display, 425T |
| 305 | 1 | AF-19187 | Bracket, Console Anchor, Right |
| 306 | 1 | AF-19188 | Bracket, Console Anchor, Left |
| 308 | 1 | DE-18556-X* | Decal, Warning, Right* |
| 309 | 1 | DE-18557-X* | Decal, Warning, Left* |
| 310 | 1 | EC-19236 | Sensor, Polar Wireless Remote Mount |
| 312 | 7 | HS-41187 | Screw, SLFTP, 8-16 x .3125, Plastite |
| 313 | 1 | HX-17788 | Tape, Double Sided, .032 Thick |
| 314 | 2 | PL-17686 | Tab, Book Holder |
| 315 | 1 | PL-18548 | Console, Plastic, 425T |
| 316 | 1 | SW-21456-X* | Membrane, 425T, Top* |
| 317 | 1 | SW-21457-X* | Membrane, 425T, Bottom* |
| 317 | 1 | SW-21458-X* | Membrane, 425T, Bottom, A/V* |
| 318 | 1 | DE-19189-X* | Label, Warning* |
| 410 | 1 | AX-19735 | Assembly, extended handrail, Left, 425T 445T |
| 411 | 1 | AX-19758 | Assembly, extended handrail, Right, 425T 445T |

Cybex 425T Treadmill Owner's Manual

| ITEM NO. | QTY. | PART NO. | DESCRIPTION |
|----------|------|-------------|---|
| 413 | 4 | HS-18127 | Bolt, 1/4-20 x 1.25", BHCS, SS, Black |
| 410 | 1 | AX-19735 | Assembly, extended handrail, Left, 425T 445T |
| 411 | 1 | AX-19758 | Assembly, extended handrail, Right, 425T 445T |
| 413 | 4 | HS-18127 | Bolt, 1/4-20 x 1.25", BHCS, SS, Black |
| 500 | 1 | AF-19876 | Bracket, Upper mount |
| 501 | 1 | AF-21142 | Weldment, PEM Mount, 2nd Gen |
| 502 | 1 | AW-17694 | Cable, Audio 1/4 in to 3.5mm, 18 in |
| 503 | 1 | AW-21680 | Cable, Locking RF & DC Power Cable, 2795mm |
| 504 | 1 | AW-20111 | Cable, 5E Bonded pair RJ45 Round |
| 505 | 1 | CN-17687 | Adapter, 1/4" Plug to 1/8" Jack |
| 506 | 1 | CP-21072 | Monitor, 13.3" ATSC NTSC PEM |
| 506 | 1 | CP-21073 | Monitor, 13.3" DVB-T SECAM PAL PEM |
| 507 | 1 | FS-17698 | Clamp, Headphone adapter |
| 509 | 2 | HS-16939 | Screw SEMS, 10-32X.75, PNHD, BLK ZN, EXT |
| 510 | 2 | HS-19369 | Screw 1/4-20 x 2.25", PNHD PHIL, BLK ZN |
| 512 | 2 | HX-12244 | Spring compression brush |
| 513 | 2 | HX-19976 | Busing, Stud plate, 8-32, 6lb Max shear, 18LB Max comp. |
| 514 | 1 | HX-20032 | Insert, domed plastic |
| 515 | 4 | HX-20220 | Plug, hole .187" DIA, Black |
| 523 | 1 | TR-21265 | Power supply, 12VDC, 120-240VAC, 6.0A W-Locking plug |
| 524 | 1 | AW-14007 | Power cord, 115V, 60HZ PWR SUPPLY IEC320 (SJT) |
| 524 | 1 | WR-14012 | Power cord, 230V, 10A, CEE 7-7, 2M |
| 524 | 1 | AW-20192 | Power cord, 100V, 50HZ, 2.5M IEC-320, Japan |
| 524 | 1 | AW-20193 | Power cord, 250VAC 10A, 2.5M IEC-320, UK |
| 524 | 1 | AW-22229 | Power cord, 10A, 250V IEC 60320 Molded, Danish |
| NS | 1 | AF-19068 | Bracket, Power Factor |
| NS | 1 | AF-19494 | Bracket, E-Stop, Micro switch mount |
| NS | 1 | AW-19117 | Cable, A/V Option |
| NS | 1 | AW-18216-Q | Cable, Harness, Console |
| NS | 1 | AW-18256 | Cable, Polar Jumper |
| NS | 1 | AW-18528-Q | Cable, Harness, Frame |
| NS | 1 | AW-18530 | Cable, Filter to Board, Hot, Black |
| NS | 1 | AW-18531 | Cable, Filter to Board, Neutral, White |
| NS | 1 | AW-18532 | Power Cord, 115 VAC |
| NS | 1 | AW-18533 | Power Cord, 230 VAC |
| NS | 1 | AW-18534 | Power Cord, 230 VAC, 50 Hz |
| NS | 1 | AW-19525 | Power Cord, 230 VAC, UK |
| NS | 1 | AW-18540 | Cable, Circuit Breaker to Filter, Hot, Black |
| NS | 1 | AW-18541 | Cable, Circuit Breaker to Filter, Neutral, White |
| NS | 1 | AW-18574 | Cable, Speed Signal |
| NS | 1 | AW-18972 | Cable, Elevation Motor |
| NS | 1 | AW-19221-Q | Cable, Contact Heart Rate Grip and Ground |
| NS | 1 | AW-19235 | Cable, Control Board, Ground |
| NS | 1 | AX-19193 | Controller Mount |
| NS | 1 | AX-19354 | Kit, Install Hardware |
| NS | 1 | DE-18413 | Decal, ETL |
| NS | 1 | CN-17687 | Adapter, 1/4 Plug to 1/8 Jack |
| NS | 2 | EH-10291 | Wire Tie, Base |
| NS | 1 | EH-19220 | Jacket, Corrugated Tubing, 27 Long |
| NS | 1 | FS-17698 | Clamp, Headphone Adapter |
| NS | 1 | FS-19190 | Controller Mount |
| NS | 1 | FS-18771 | Cover, Lower, Motor Controller |
| NS | 1 | HX-19059 | Plug, Tube End, 1.5 O.D. |
| NS | 1 | LT-03051 | Sign Facility Safety |
| NS | 1 | LT-19339 | Warranty Sheet, 425T, Commercial |
| NS | 1 | LT-19453 | Warranty Sheet, 425T, Consumer |
| NS | 1 | LT-19340 | Poster, Installation |
| NS | 1 | LT-19431-X* | Owner's Manual, 425T |
| NS | 1 | SK-18553 | Kit Brush, McMillan 3.0HP 110V |
| NS | 1 | SK-18554 | Kit Brush, McMillan 3.0HP 220V |
| NS | 1 | TR-19201 | Choke |

NOTE: NS = Not Shown

*Language Key

1-German, 2-French, 3-Spanish, 4-English, 6-Japanese, 7-Swedish 8-Russian, A-Danish

This page intentionally left blank

Appendix D – Exploded Views

| ITEM QTY. | PART NO. | DESCRIPTION |
|-----------|----------|--|
| 19 | EH-00986 | Wire Tie, 9" |
| 20 | EH-10291 | Base, Wire Tie |
| 42 | HW-00180 | Washer, Split Lock, 1/4, SST, BLK |
| 70 | HS-11977 | Screw, SEMS, 8/32 x .38, PNHD |
| 500 | AF-19876 | Bracket, Upper mount |
| 501 | AF-21142 | Weldment, PEM Mount, 2nd Gen |
| 502 | AW-17694 | Cable, Audio 1/4 in to 3.5mm, 18 in |
| 503 | AW-21680 | Cable, Locking RF & DC Power Cable, 2795mm |
| 504 | AW-20111 | Cable, 5E Bonded pair RJ45 Round |
| 505 | CN-17687 | Adapter, 1/4" Plug to 1/8" Jack |
| 506 | CP-21072 | Monitor, 13.3" ATSC NTSC PEM |
| 506 | CP-21073 | Monitor, 13.3" DVB-T SECAM PAL PEM |
| 507 | FS-17698 | Clamp, Headphone adapter |
| 509 | HS-16939 | Screw SEMS, 10-32X.75, PNHD, BLK ZN, EXT |
| 510 | HS-19369 | Screw 1/4-20 x 2.25", PNHD PHIL, BLK ZN |
| 512 | HX-12244 | Spring compression brush |
| 513 | HX-19976 | Bushing, Stud plate, 8-32, 6lb Max shear, 18LB Max comp. |
| 514 | HX-20032 | Insert, domed plastic |
| 515 | HX-20220 | Plug, hole .187" DIA, Black |
| 523 | TR-21265 | Power supply, 12VDC, 120-240VAC, 6.0A W-Locking plug |
| 524 | AW-14007 | Power cord, 115V, 60HZ PWR SUPPLY IEC320 (SJT) |
| 524 | WR-14012 | Power cord, 230V, 10A, CEE 7-7, 2M |
| 524 | AW-20192 | Power cord, 100V, 50HZ, 2.5M IEC-320, Japan |
| 524 | AW-20193 | Power cord, 250VAC 10A, 2.5M IEC-320, UK |
| 524 | AW-22229 | Power cord, 10A, 250V IEC 60320 Molded, Danish |

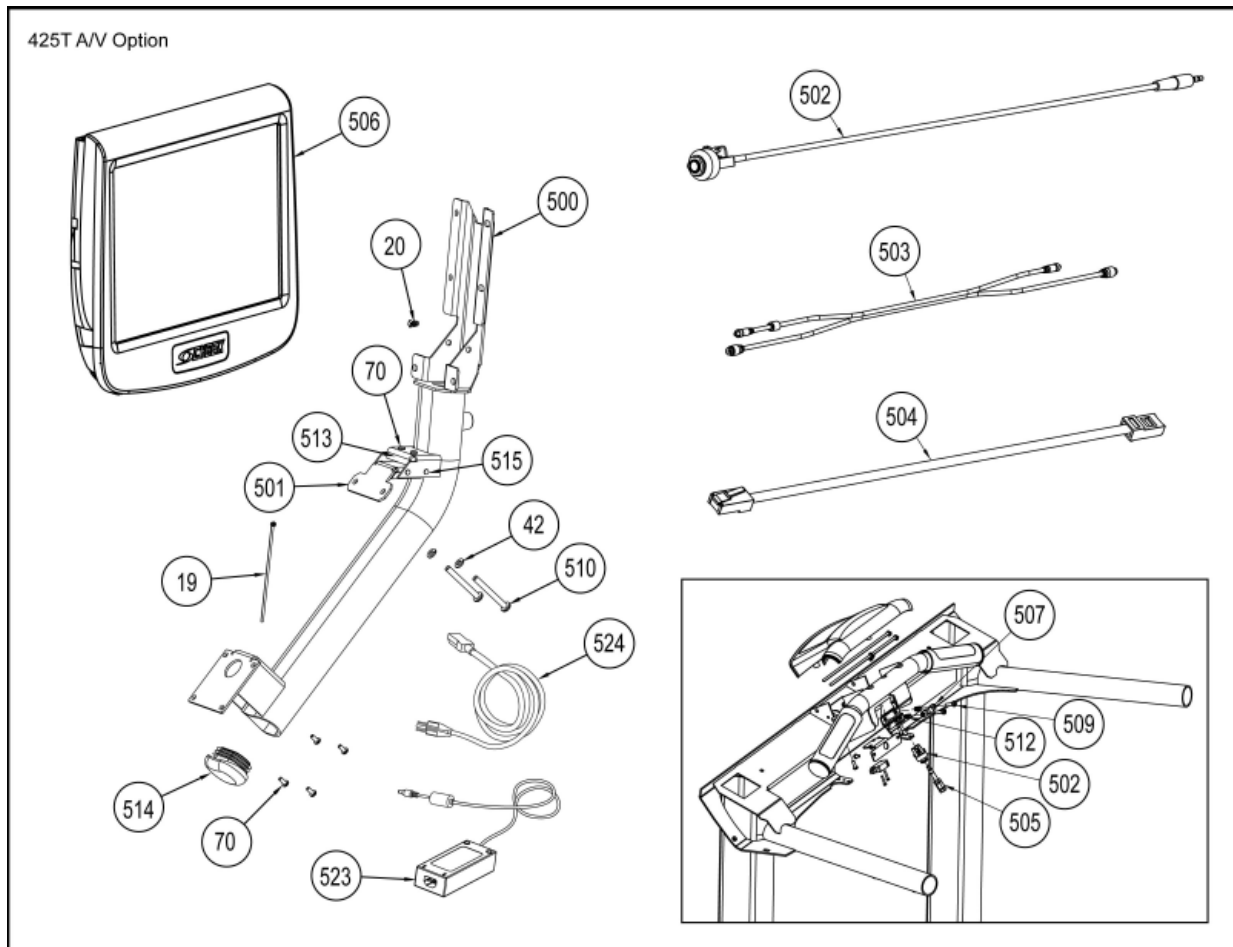

Cybex 425T Treadmill Owner's Manual

| ITEM | QTY. | PART NO. | DESCRIPTION |
|------|------|-----------|---|
| 2 | 1 | AL-18596 | Front Roller, 2.75 O.D. |
| 3 | 1 | AL-18597 | Rear Roller, 2.75 O.D. |
| 8 | 1 | AX-18729 | Assembly, Idler |
| 11 | 1 | BD-18763 | Belt, Running |
| 12 | 1 | BD-18917 | Belt, Poly-V,320J8 |
| 17 | 1 | DK-18401 | Deck, Running |
| 18 | 1 | KAX-21507 | Sensor, Speed |
| 26 | 2 | HB-16367 | Bushing, .50 I.D. x .62 O.D. x .31 LG, Flanged |
| 27 | 2 | HN-10029 | Nut, 1/2 - 13 HEX STL ZINC |
| 30 | 2 | HS-00261 | Bolt, 1/2 - 13 x 5.5, HXHD |
| 33 | 10 | HS-16628 | Bolt, 1/4 - 20 x 1.5, HXHD, G8 |
| 34 | 6 | HS-16929 | Bolt, Whiz Lock, 3/8 - 16 x .625, HXHD, G5 |
| 40 | 2 | HS-41107 | Bolt, 5/16 - 18 x 1.5, BTHD, SST, BLK |
| 41 | 2 | HW-00165 | Washer, Split Lock, 5/16, ZINC |
| 42 | 8 | HW-00180 | Washer, Split Lock, 1/4, SST, BLK |
| 43 | 2 | HW-00590 | Bushing, Nylon, 1/2 |
| 44 | 12 | HW-18123 | Washer, .344 I.D. x .75 O.D. x .125 Thick, Black Zinc |
| 45 | 2 | HX-13771 | Ring, Retaining, 5/8 x .579 FR. I.D. |
| 46 | 2 | HX-19981 | Bushing, Deck, 5/16 - 18 |
| 49 | 1 | HX-19529 | E-Ring, Retaining, 5555-37 |
| 51 | 1 | HX-19052 | Idler Spring |
| 220 | 1 | FM-19513 | Shaft, Deck Pivot |
| 221 | 2 | AX-20035 | Assembly, Deck Pivot Bracket |
| 222 | 2 | HB-18768 | Bearing, IGUS LF-1011-12 |
| 223 | 2 | HS-19108 | Bolt, 5/16-18X3-4LG,HxHd,Whiz |

425T Belt, Deck and Rollers

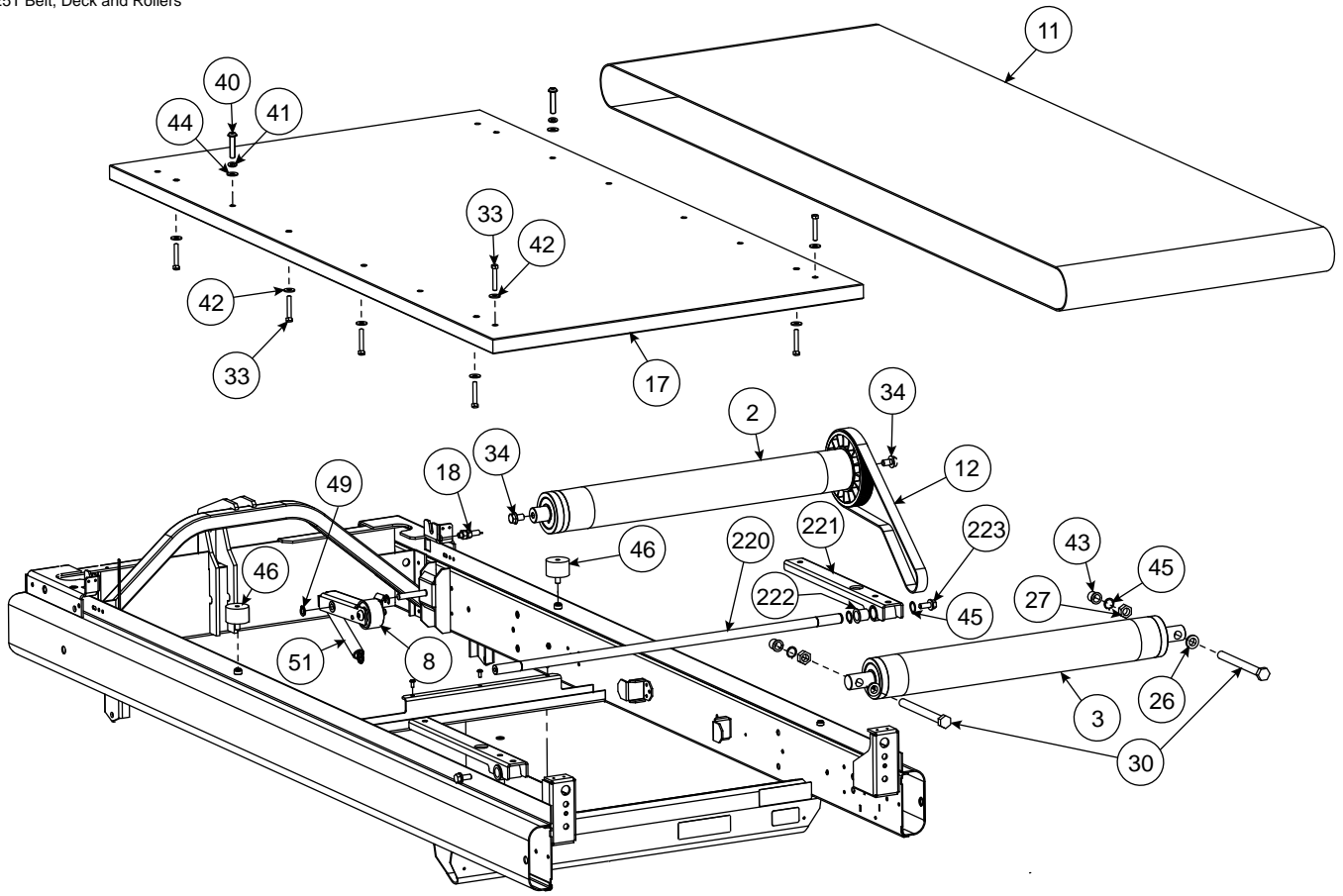

Cybex 425T Treadmill Owner's Manual

| ITEM QTY. | PART NO. | DESCRIPTION | ITEM QTY. | PART NO. | DESCRIPTION |
|-----------|-------------|---|-----------|-------------|--------------------------------------|
| 1 | AF-18899 | Weldment, Console Back Plate | 306 | AF-19188 | Bracket, Console Anchor, Left |
| 9 | AX-20944 | Assembly, E-Stop Lanyard | 308 | DE-18556-X* | Decal, Warning, Right |
| 31 | HS-15706 | Screw, 8-16 x .50, PNHD, STL, BLK ZN CLR, TYP WB | 309 | DE-18557-X* | Decal, Warning, Left |
| 64 | PL-19061 | Cover, Console, Back Trim, 425T | 310 | EC-19236 | Sensor, Polar Wireless Remote Mount |
| 70 | HS-11977 | Screw, SEMS, 8/32 x .38, PNHD | 312 | HS-41187 | Screw, SLFTP, 8-16 x .3125, Plastite |
| 104 | DE-20685 | Decal, E-stop, Yellow | 313 | HX-17788 | Tape, Double Sided, .032 Thick |
| 211 | HX-18287 | Plug, Hole, Plastic, 1", Black | 314 | PL-17686 | Tab, Book Holder |
| 300 | AX-18545-X* | Assembly, 425T Console | 315 | PL-18548 | Console, Plastic, 425T |
| 304 | AD-21467 | PCA, Display, 425T | 316 | SW-21456-X* | Membrane, 425T, Top |
| 305 | AF-19187 | Bracket, Console Anchor, Right | 317 | SW-21457-X* | Membrane, 425T, Bottom |
| | | | 317 | SW-21458-X* | Membrane, 425T, Bottom, A/V |

*Language Key
 1-German 2-French 3-Spanish 4-English 6-Japanese 7-Swedish 8-Russian A-Danish

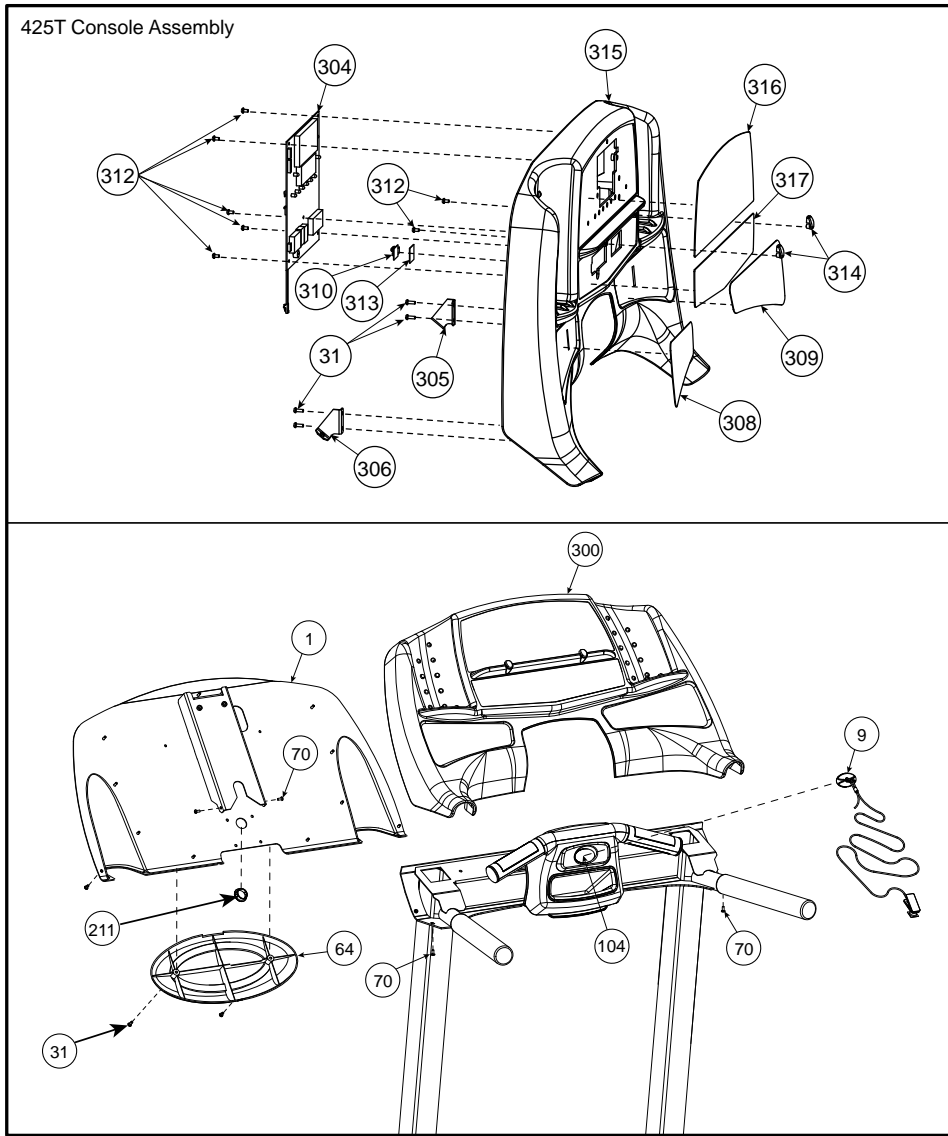

Cybex 425T Treadmill Owner's Manual

| ITEM QTY. | PART NO. | DESCRIPTION |
|-----------|----------|---|
| 38 | 4 | HS-19108 Screw 5/16-18 x 3/4, HXHD, Whiz-Lock |
| 70 | 8 | HS-11977 Screw, SEMS, 8/32 x .38, PNHD |
| 78 | 1 | AF-18481 Weldment, Motor Base |
| 79 | 1 | AF-18769 Bracket, Heat Sink |
| 80 | 2 | HB-18768 Bearing, LF-1011-12 |
| 81 | 1 | AD-18213 PCA, Control Board, 115 VAC |
| 81 | 1 | AD-18217 PCA, Control Board, 230 VAC |
| 82 | 2 | EC-18538 Circuit Breaker, 15 Amp, 115 VAC |
| 82 | 2 | EC-18539 Circuit Breaker, 10 Amp, 250 VAC |
| 83 | 1 | EC-18896 Filter, 16 Amp |
| 84 | 4 | HN-11136 KEPS, 5/16 - 18, HEX STL ZINC |
| 86 | 8 | EH-00986 Wire Tie, Nylon, 9 |
| 87 | 2 | HN-11925 KEPS, 10-32, HEX STL ZN |
| 88 | 1 | HW-10856 Washer, Lock External, No. 10 ZC |
| 89 | 2 | HS-15732 Screw, SEMS, 8-32 UNC x .62, PNHD PHIL, ZN |
| 90 | 1 | EH-12260 Wire Tie, Nylon, 18 |
| 91 | 1 | FS-19355 Plate, Circuit Breaker Mount |
| 92 | 1 | DE-16928 Label, Disconnect Power, Multilingual |
| 93 | 1 | DE-19238 Decal, Warning, Motor Plate |
| 103 | 1 | MR-19643 Motor, Drive, 115 VAC |
| 103 | 1 | AX-19650 Motor, Drive, 230 VAC |
| 120 | 1 | EH-19416 Heat Sink, Silpad |
| 121 | 1 | EC-15004 Ferrite, Clamp-on, .40 I.D. |

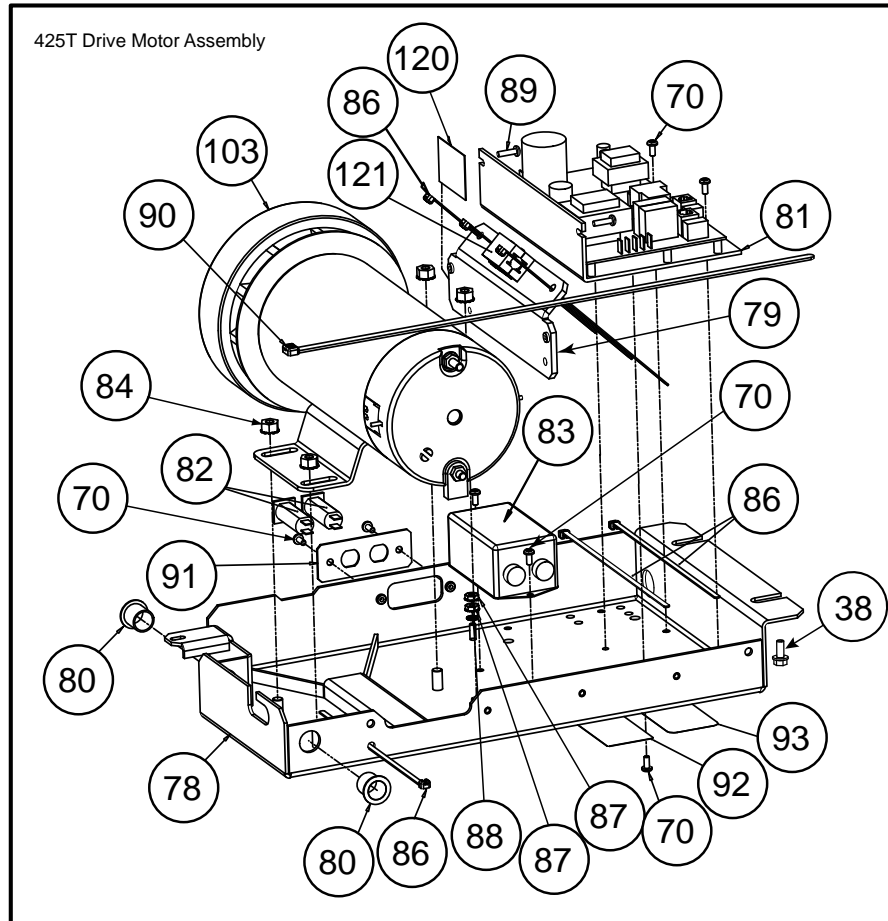

Cybex 425T Treadmill Owner's Manual

| ITEM QTY. | PART NO. | DESCRIPTION |
|-----------|----------|---|
| 7 | AF-18394 | Weldment, Elevation |
| 21 | FM-18405 | Shaft, Elevation |
| 24 | FT-16825 | Sleeve, Elevation Mounting, Top |
| 25 | FT-16826 | Sleeve, Elevation Mounting, Bottom |
| 28 | HN-17935 | Nut Locking, 3/8 - 24, GRD C, STL, ZN |
| 36 | HS-17936 | Bolt, 3/8 - 24 x 2.0, HXHD CAP, G8, YEL ZN |
| 37 | HS-17937 | Bolt, 3/8 - 24 x 2.75, HXHD CAP, G8, YEL ZN |
| 38 | HS-19108 | Screw 5/16-18 x 3/4, HXHD, Whiz-Lock |
| 53 | HX-19384 | Coupling, Shaft, DBL Split 5/8 |
| 73 | HX-22247 | Busing, Spanner,.500 OD X 1.5"L |
| 74 | CW-22240 | Wheel, 3 Dia. x 1.25 W, Plain Bearing |
| 75 | HB-18768 | Bearing, LF-1011-12 |
| 76 | HS-60022 | Bolt, 3/8 x 2.25, HXHD CAP, Black Zinc, G5 |
| 77 | HN-60064 | Nut, Jam 3/8 - 16, Black Zinc |
| 102 | MR-18402 | Motor, Elevation, 115 VAC |
| 102 | MR-18403 | Motor, Elevation, 230 VAC |

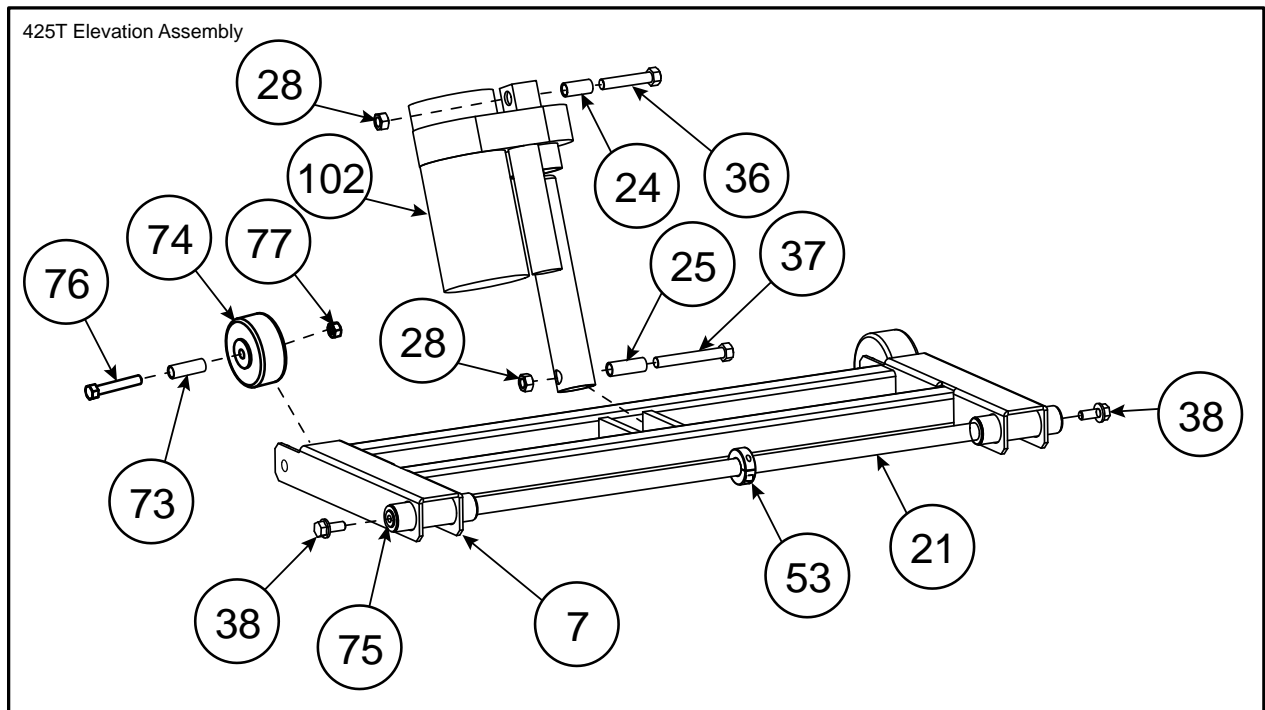

Cybex 425T Treadmill Owner's Manual

| ITEM QTY. | PART NO. | DESCRIPTION | ITEM QTY. | PART NO. | DESCRIPTION | | |
|-----------|----------|-------------|--|----------|-------------|-----------|--|
| 10 | 1 | AX-19239 | Assembly, Motor Cover | 61 | 1 | PL-18990 | Cover, Motor, Front, 425T |
| 15 | 2 | DE-19360 | Decal, Side Labels, Black | 62 | 1 | PL-18991 | Cover, Motor, Right, 425T |
| 15 | 2 | DE-19353 | Decal, Side Labels, Silver | 63 | 1 | PL-18992 | Cover, Motor Left, 425T |
| 18 | 1 | EC-18573 | Sensor, Speed | 94 | 1 | DE-19198 | Decal, Cybex |
| 22 | 4 | FS-16511 | Plate, Rear Rubber Foot Mounting | 200 | 1 | SCK-18765 | Assembly, Top Platform, Right |
| 23 | 1 | FS-19213 | Cable, Connector Plate, 425T | 201 | 1 | SCK-18764 | Assembly, Top Platform, Left |
| 31 | 4 | HS-15706 | Screw, 8-16 x .50, PNHD, STL, BLK ZN CLR, TYP WB | 203 | 1 | AF-18461 | Weldment, Frame, 425T |
| 32 | 10 | HS-16509 | Screw, SLFTP, 10 x .5, PNHD, PLT, TYP B, PT-S | 204 | 1 | DE-18766 | Decal, Safety Walk |
| 35 | 8 | HS-16939 | Screw, SEMS, 10/32 x .75, PNHD, BLK ZN, EXT | 205 | 6 | HS-18311 | Screw, 8-16 x .75", PNHD, STL, BLK ZN CLR, TYP WB |
| 39 | 1 | HS-41006 | Screw, SLFTP, 10/24 x 1.38, PNHD PHIL, SST, BLK, TT | 206 | 1 | PL-18931 | Cover, Rear, Top Left |
| 46 | 2 | HX-19981 | Bushing, Deck, 5/16 - 18 | 207 | 1 | PL-19120 | Cover, Rear, Bottom Left |
| 52 | 2 | HX-19102 | Rubber Foot, Rear | 208 | 1 | PL-18928 | Cover, Rear, Top Right |
| 57 | 1 | PL-18929 | Cover, Rear, Outer Right | 209 | 1 | PL-19118 | Cover, Rear, Bottom Right |
| 58 | 1 | PL-18930 | Cover, Rear, Inner Right | 210 | 1 | DE-19441 | Decal, 425T, Black |
| 59 | 1 | PL-18932 | Cover, Rear, Outer Left | 210 | 1 | DE-19442 | Decal, 425T, Silver 877 |
| 60 | 1 | PL-18933 | Cover, Rear, Inner Left | 222 | 2 | DE-22327 | LABEL, BLACK, INTELLIGENT SUSPENSION 3 |
| | | | | 223 | 2 | DE-22328 | LABEL, SILVER, INTELLIGENT SUSPENSION 3 |

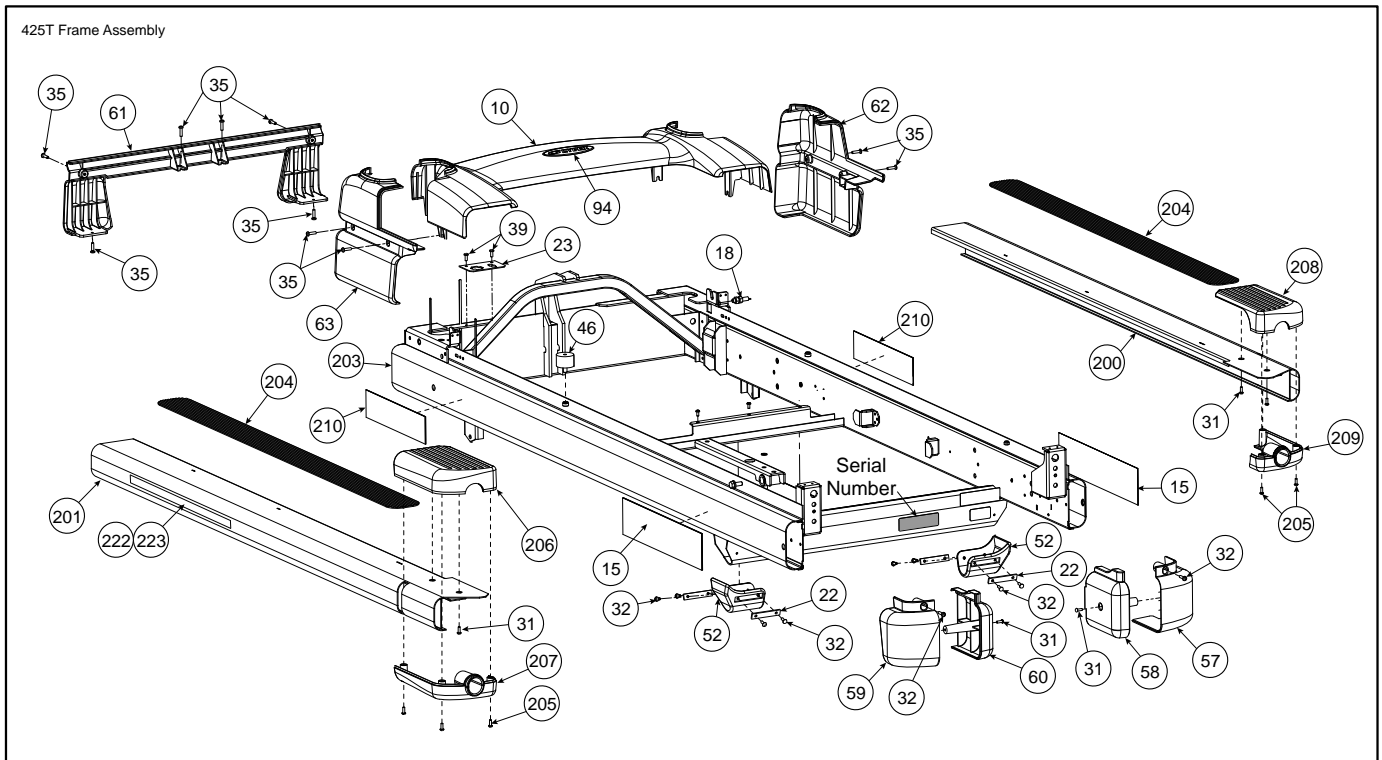

Cybox 425T Treadmill Owner's Manual

| ITEM QTY. | PART NO. | DESCRIPTION | |
|-----------|----------|-------------|---|
| 95 | 1 | AF-18728 | Bracket, Idler |
| 96 | 1 | HB-19135 | Idler Wheel, 1.88 x 1.0 |
| 97 | 2 | HB-18056 | Bushing, Flange, .375 x .469 x .25 |
| 98 | 1 | HS-19338 | Screw, 3/8 - 16 x 1.75, SCHD BTN, BLK, ZN |

425T Idler Pulley Assembly

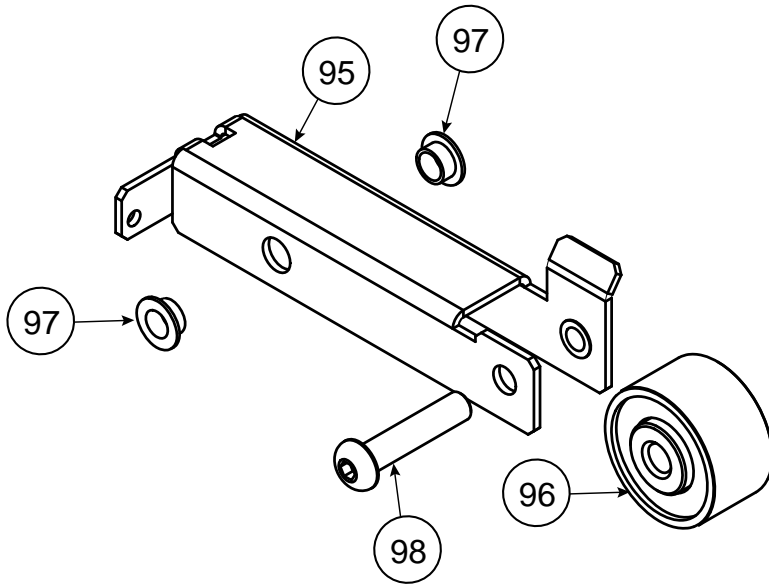

Cybex 425T Treadmill Owner's Manual

| ITEM QTY. | PART NO. | DESCRIPTION |
|-----------|----------|--|
| 6 | 1 | SK-17827 Assembly, Contact Grip, Pair |
| 19 | 1 | EH-00986 Wire Tie, 9" |
| 20 | 1 | EH-10291 Base, Wire Tie |
| 29 | 2 | HS-00156 Screw, 4-40 x .62, PNHD PHIL |
| 31 | 10 | HS-15706 Screw, 8-16 x .50, PNHD, STL, BLK ZN CLR, TYP WB |
| 39 | 1 | HS-41006 Screw, SLFTP, 10/24 x 1.38, PNHD PHIL, SST, BLK, TT |
| 47 | 1 | HX-20799 Plug, Plastic, 9/16", BLACK |
| 48 | 4 | HX-17788 Tape, Double Sided, .032 Thick |
| 50 | 2 | HX-18901 Grips, 425 Upright Handrail |
| 56 | 1 | PL-18773 Plunger, E-Stop |
| 65 | 1 | PL-19093 Cover, Handle Lower |
| 66 | 1 | PL-19094 Accessory Tray, 425T Console |
| 68 | 1 | W-18535 Switch, Limit |
| 202 | 1 | SCK-18486 Weldment, Upright |
| 301 | 1 | AX-19356-X Assembly, Cover, Top CHR |
| 318 | 1 | DE-19189-X Label, Warning* |
| 42 | 4 | HW-00180 Washer, Split Lock 1/4" |
| 410 | 1 | AX-19735 Assembly, extended handrail, Left, 425T 445T |
| 411 | 1 | AX-19758 Assembly, extended handrail, Right, 425T 445T |
| 413 | 4 | HS-18127 Bolt, 1/4-20 x 1.25",BHCS,SS,Black |

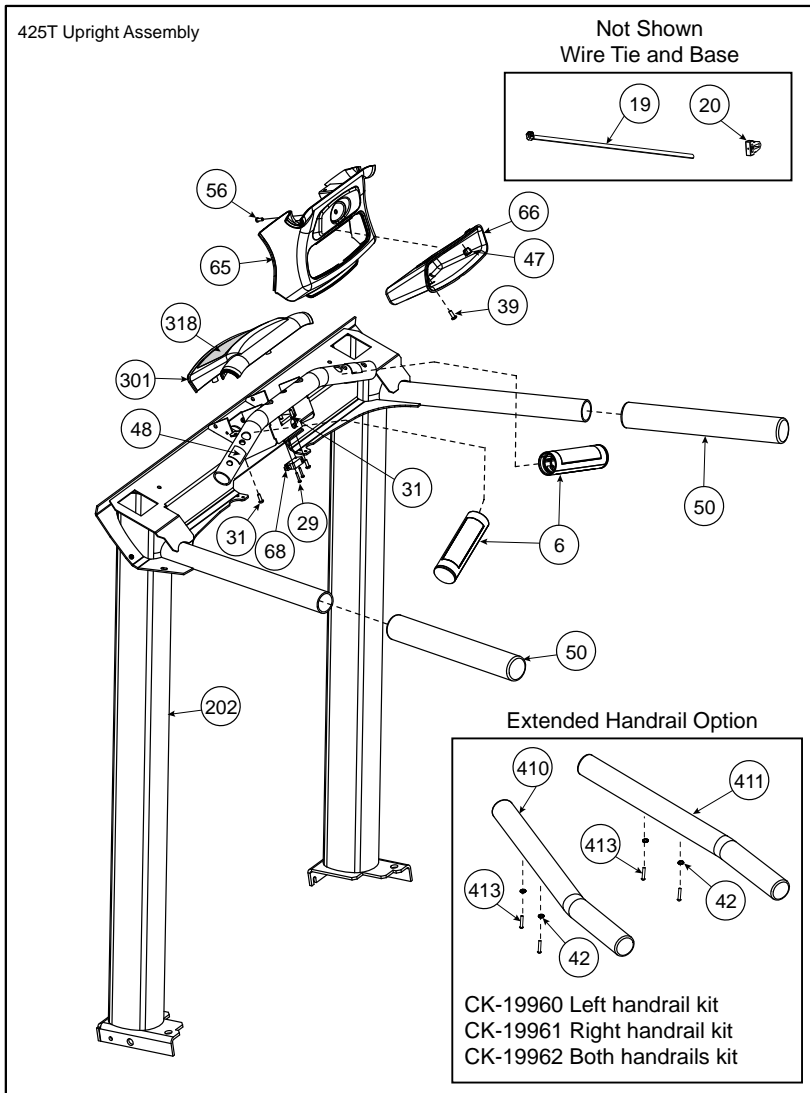

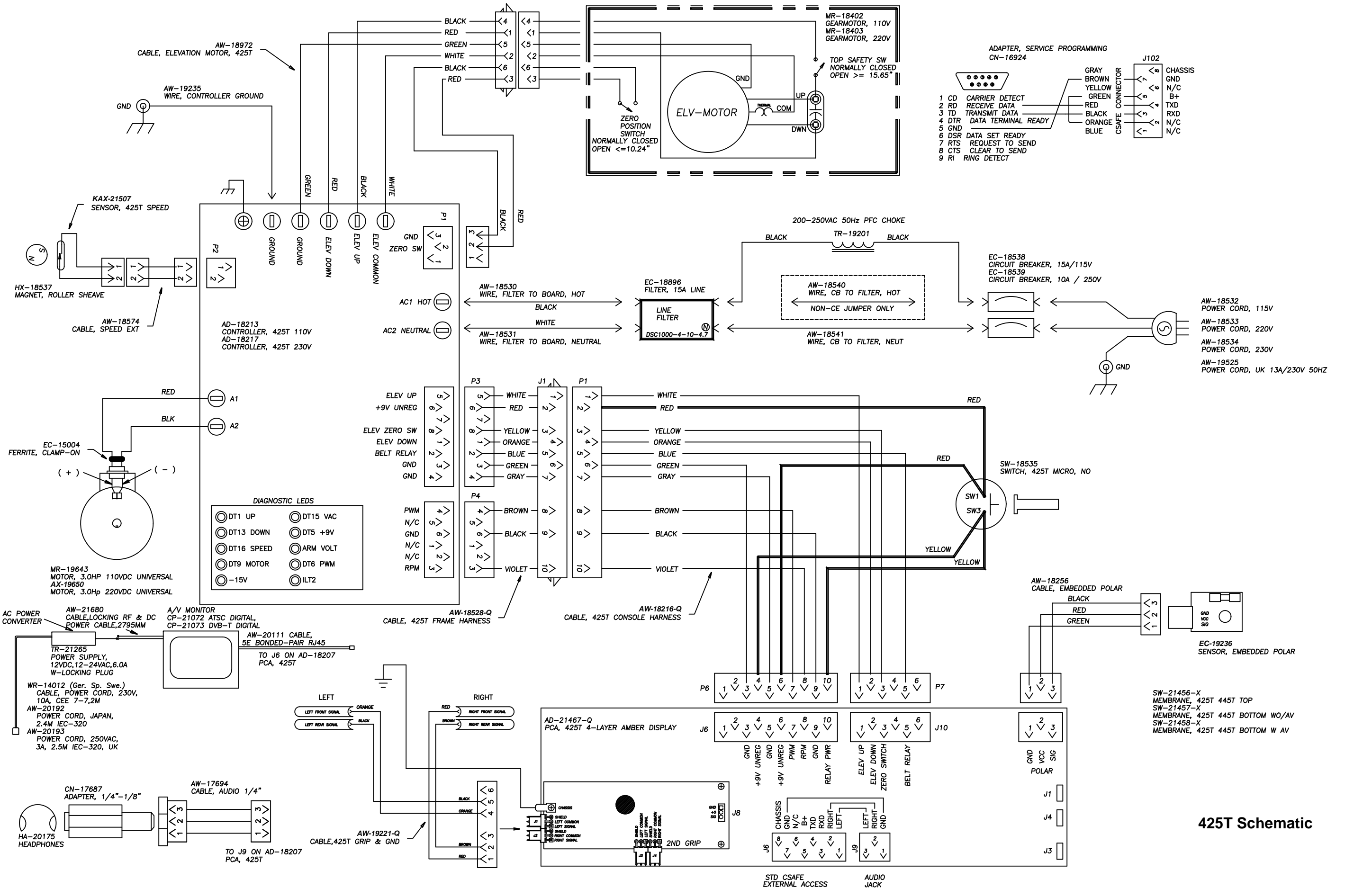

425T Schematic

This page intentionally left blank