



Cybex 770C/770R Cycle
Owner's Manual
Cardiovascular Systems
Part Number LT-23694-4 D

Table of Contents

Safety

Grounding and Voltage Information	4
Important Safety Instructions	5
Warning and Caution Decals	6
Warning and Caution Decals - 770C	7
Label Placement - 770C	8
Warning and Caution Decals - 770R	9
Label Placement - 770R	10

Assembly

Specifications	11
Choosing and Preparing a Site	12
Electrical Power Requirements	13
Unit Assembly	13
770C Assembly	14
770R Assembly	20
Setup	27
A/V Configuration and FM Radio Presets	29
E3 View Monitor Controls	35
E3 View Monitor Setup	36
Testing the Operation	44

Operation

Intended Use	45
Terms Used	45
User Control Symbols Used	46
CardioTouch Symbols Used	47
Console Display	49
User Controls	50
Mount and Dismount	51
Emergency Dismount	51
Quick Operation Guide	52
Detailed Operation Guide	52
Workout Selection	55
Data Readouts	56
E3 View Monitor Screen (Optional)	57

Heart Rate Indicator	58
Fan Control	58
iPod Functions	59
Battery Sentry	59

Preventive Maintenance

Warnings	60
Cleaning Unit	61
Preventive Maintenance Activities	61
Rechargeable Battery	62
Environment	62

Customer Service

Product Registration	63
Contacting Service	63
Ordering Parts	63
Return Material Authorization (RMA)	64
Damaged Parts	64

Appendix - Workout Overviews

Weight Loss - Rollers 1	65
Weight Loss - Rollers 2	66
Weight Loss - Hills	67
Weight Loss - Peaks	68
Cardio - Ramps	69
Cardio - Interval	70
Cardio - Bursts	71
Cardio - Wave	72
Cardio - Heartrate Control	73
Power - Constant Power	76
Power - Isokinetic	76
Tests - YMCA	76

Cybox® and the Cybox logo are registered trademarks of Cybox International, Inc. Polar® is a registered trademark of Polar Electro Inc. iPod® is registered trademark of Apple.

DISCLAIMER: Cybox International, Inc., makes no representations or warranties regarding the contents of this manual. We reserve the right to revise this document at any time or to make changes to the product described within it without notice or obligation to notify any person of such revisions or changes.

© Copyright 2013, Cybox International, Inc. All rights reserved. Printed in the United States of America.

10 Trotter Drive, Medway, MA 02053 • 508-533-4300 • FAX 508-533-5183 • www.cyboxintl.com • LT-23694-4 D • September 2013

FCC Compliance Information

Changes or modifications to this unit not expressly approved by the party responsible for compliance could void the user's authority to operate the equipment.

This equipment has been tested and found to comply with the limits for a Class B digital device, pursuant to part 15 of the FCC Rules. These limits are designed to provide reasonable protection against harmful interference in a residential installation. This equipment generates, uses and can radiate radio frequency energy and, if not installed and used in accordance with the instructions, may cause harmful interference to radio communications. However, there is no guarantee that interference will not occur in a particular installation. If this equipment does cause harmful interference to radio or television reception, which can be determined by turning the equipment off and on, the user is encouraged to try to correct the interference by one or more of the following measures:

- Reorient or relocate the receiving antenna.
- Increase the separation between the equipment and receiver.
- Connect the equipment into an outlet on a circuit different from that to which the receiver is connected.
- Consult the dealer or an experienced radio/TV technician for help.

Safety

 Read all instructions and warnings before using.

Grounding and Voltage Information

AC Power Adapter is optional.







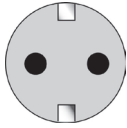
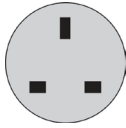

WARNING: Shock and electrocution hazard

- Connect unit to a grounded outlet.
- Do not use voltage adapter or extension cord.

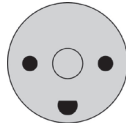
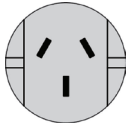
Cybox is not responsible for injuries or damages as a result of cord or plug modification.

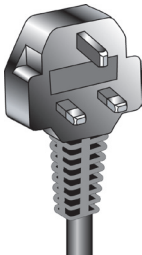
- Verify voltage requirements of unit match local voltage requirements.
- Verify unit outlet is the same configuration as the plug.

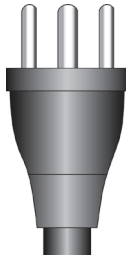
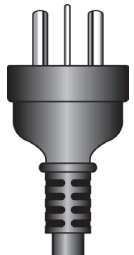
					
					
115 VAC	Euro Plug	UK 230 VAC	Japanese	Danish	Australia
NEMA 5-15	CEE 7/7	BS 1363	JIS 8303	107-2-D1	AS/NZS 3112

Important Safety Instructions

(Save These Instructions)



WARNING: Shock and electrocution hazard

- Unplug unit and let sit 10 minutes before cleaning or performing maintenance
- Electrical charge can remain in unit after unplugging
- Keep water and liquids away from electrical parts

User Safety Precautions

Prior to use:

- Obtain a medical exam before beginning any exercise program.
- Obtain instruction before using.
-  Read and understand warning labels.
- Maximum user weight is 400 lbs. (180 kg).
- Inspect unit. If damaged, notify floor staff. DO NOT USE.
- Do not remove this label. Replace if damaged or illegible.

During use:

- Do not use for stretching and do not attach straps or other devices.
- Do not allow children 12 or younger to be on or near machine.
- Stop exercise if feeling faint, dizzy, or have pain.
- Use the handrails for support and to maintain balance.
- Keep all body parts, clothing, and accessories, clear of moving parts.

Facility Safety Precautions

It is the sole responsibility of the user/owner or facility operator to ensure that regular maintenance is performed.

- Enforce all user and safety precautions.
- Read and understand the Owner's Manual completely before assembling, servicing or using unit.
- Verify all users are properly trained on using the equipment.
- Do not use unit outdoors.
- Verify that each unit is setup, leveled and operated on a solid, level surface. Do not install equipment on an uneven surface.
- Verify there is enough room for safe access and operation of unit.
- Use Cybex AC power adapters only.
- Do not use the optional power adapter in damp or wet locations.
- Do not use the unit if: (1) the unit is plugged into an optional power adapter that has a damaged cord; (2) the unit is not working properly or (3) if the unit has been dropped or damaged. Seek service from a qualified technician.
- EQUIPMENT is not suitable for use in the presence of aerosol (spray), FLAMMABLE ANAESTHETIC MIXTURE WITH AIR or WITH OXYGEN or NITROUS OXIDE.
- Perform regular maintenance checks on unit. Performance level can be maintained only if examined regularly. Pay close attention to all areas most susceptible to wear, including (but not limited to) cables, pulleys, belts and grips.
- Replace any warning labels if damaged, worn or illegible.

- Immediately replace worn or damaged components. If unable to immediately replace worn or damaged components, then remove unit from service until repair is made.
- Do not attempt repairs; electrical or mechanical. Seek qualified repair technician when servicing. Failure to do so could result in serious injury. See Customer Service for contact information.
- Use only Cybex supplied components to maintain/repair unit.
- Keep a repair log of all maintenance activities.
- Disconnect the optional power adapter before servicing unit.
- Do not use attachments unless recommended for the unit by Cybex.
- The unit may generate electromagnetic or other forms of interference, or it may be affected by interference from other equipment nearby. If this is suspected, take precautions by separating the equipment or otherwise shielding it to avoid such interference.

Warning and Caution Decals

To replace any worn or damaged decals do one of the following: Visit www.cybexintl.com to shop for parts online, fax orders to 508-533-5183 or contact Cybex Customer Service at 888-462-9239. If you are located outside of the USA, call 508-533-4300. For location or part number of labels, see the parts list and exploded-view diagram on the Cybex web site at www.cybexintl.com.

Warning decals indicate a potentially hazardous situation which, if not avoided, could result in death or serious injury.

Carefully read and understand the following caution and warning labels before using the unit.

Warning and Caution Decals - 770C

⚠ WARNING	Serious injury could occur if these precautions are not observed
Heart rate monitoring systems may be inaccurate. Over exercise may result in serious injury or death. If you feel faint, stop exercising immediately.	
Prior to use: <ul style="list-style-type: none"> • Obtain a medical exam before beginning any exercise program. • Obtain instruction before using. • Read and understand warning labels.  • Maximum user weight is 400 lbs. (180 kg). • Inspect unit. If damaged, notify floor staff. DO NOT USE. • Do not remove this label. Replace if damaged or illegible. 	
During use: <ul style="list-style-type: none"> • Do not use for stretching and do not attach straps or other devices. • Do not allow children 12 or younger to be on or near machine. • Stop exercise if feeling faint, dizzy, or have pain. • Use the handrails for support and to maintain balance. • Keep all body parts, clothing, and accessories, clear of moving parts. 	
DE-23739-4 B	

⚠ WARNING
Shock and electrocution hazard. <ul style="list-style-type: none"> • Unplug unit and let sit 10 minutes before cleaning or performing maintenance. • Electrical charge can remain in unit after unplugging. • Keep water and liquids away from electrical parts.
DE-21749-4 C

⚠ CAUTION
Moving parts hazard. To avoid injury, keep hands and fingers away when in use.
DE-18362-4 B

⚠ WARNING
Burn hazard. Do not touch flywheel until cool.
DE-18363-4 C

⚠ AVERTISSEMENT
Des blessures graves pourraient se produire si ces précautions ne sont pas respectées
Les systèmes de surveillance de la fréquence cardiaque peuvent être inexacts. Un exercice intensif peut entraîner des blessures graves ou la mort. Si vous ressentez une sensation de malaise, arrêter immédiatement l'exercice.
Conseils d'utilisation : <ul style="list-style-type: none"> • Obtenir un examen médical avant de commencer tout programme d'exercice. • Obtenir des instructions avant toute utilisation. • Lire et comprendre les étiquettes d'avertissement.  • Lire et comprendre les procédures d'arrêt d'urgence. • Le poids maximum de l'utilisateur ne doit pas dépasser 180 kg (400 lb). • Inspecter l'appareil. S'il est endommagé, en aviser le personnel. NE PAS UTILISER. • Placer vos pieds sur les deux premières marches lors du démarrage ou de l'arrêt du tapis roulant. • Clip E-STOP lanière aux vêtements. • Ne pas enlever cette étiquette. Remplacer si endommagé ou illisible.
Pendant l'utilisation : <ul style="list-style-type: none"> • Ne pas utiliser pour les étirements et ne pas attacher des sangles ou autres dispositifs. • Ne pas permettre aux enfants de 12 ans ou moins de rester près de la machine. • Arrêter l'exercice si vous ressentez une faiblesse, un étourdissement ou une douleur. • Utiliser des rampes de soutien pour maintenir l'équilibre. • Garder votre corps, vos vêtements et vos accessoires éloignés des pièces mobiles. • Attendre l'arrêt complet de la bande de roulement avant de descendre.
DE-24016-2 B

Label Placement - 770C

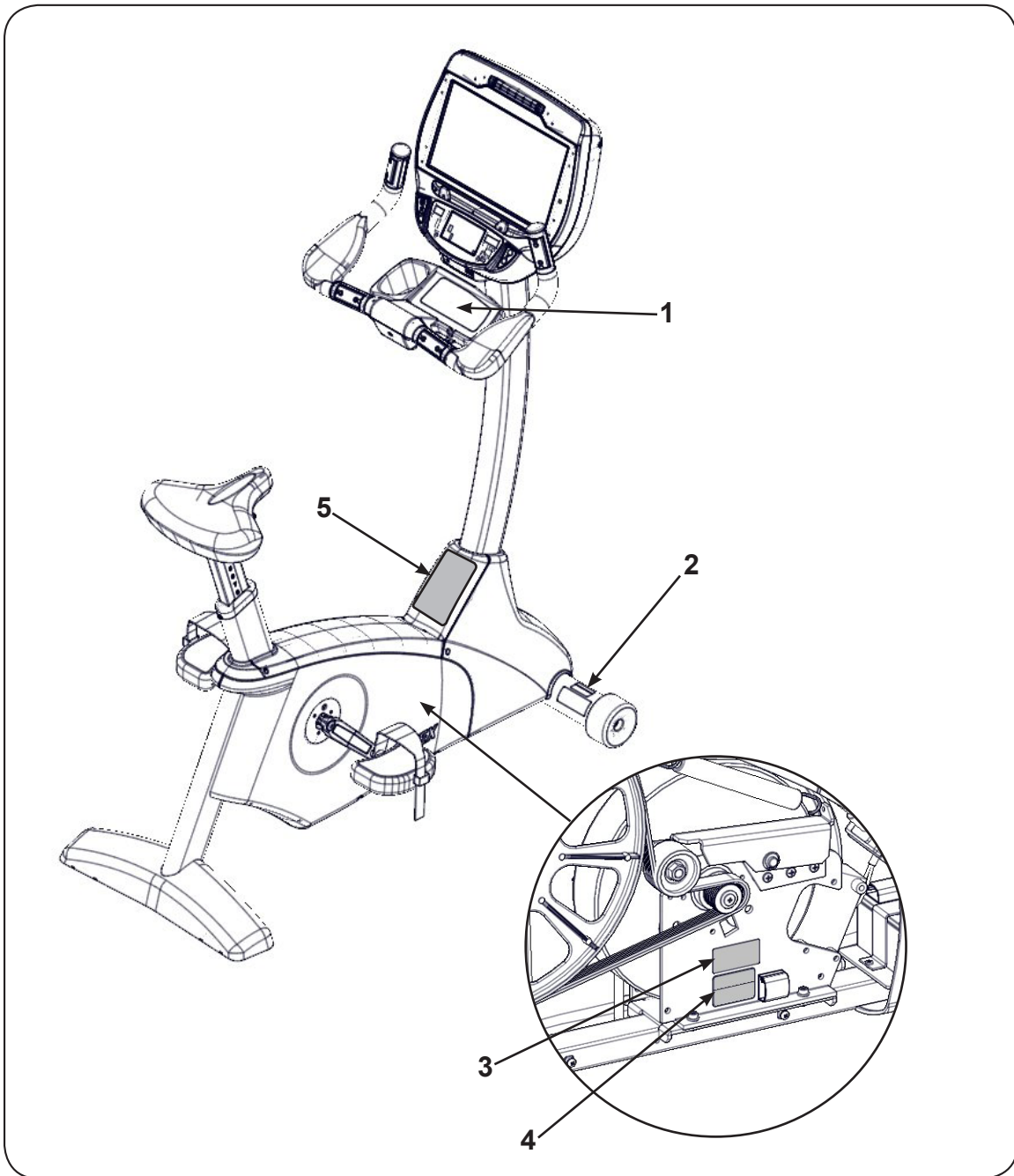

1	DE-23739-4	Label, Warning, Access tray,
2	DE-21749-4	Label, Warning, Disconnect Power
3	DE-18363-4	Label, Warning, Hot flywheel
4	DE-18362-4	Decal, Caution moving parts
5	DE-24016-2	Label, Warning, Canada

Warning and Caution Decals - 770R

⚠ WARNING	Serious injury could occur if these precautions are not observed
Heart rate monitoring systems may be inaccurate. Over exercise may result in serious injury or death. If you feel faint stop exercising immediately.	
Prior to use: <ul style="list-style-type: none"> • Obtain a medical exam before beginning any exercise program. • Obtain instruction before using. • Read and understand warning labels.  • Maximum user weight is 400 lbs. (180 kg). • Inspect unit. If damaged, notify floor staff. DO NOT USE. • Do not remove this label. Replace if damaged or illegible. 	
During use: <ul style="list-style-type: none"> • Do not use for stretching and do not attach straps or other devices. • Do not allow children 12 or younger to be on or near machine. • Stop exercise if feeling faint, dizzy, or have pain. • Use the handrails for support and to maintain balance. • Keep all body parts, clothing, and accesories, clear of moving parts. 	
DE-23740-4 B	

⚠ WARNING
Shock and electrocution hazard. <ul style="list-style-type: none"> • Unplug unit and let sit 10 minutes before cleaning or performing maintenance. • Electrical charge can remain in unit after unplugging. • Keep water and liquids away from electrical parts.
DE-21749-4 C

⚠ AVERTISSEMENT
Des blessures graves pourraient se produire si ces précautions ne sont pas respectées
Les systèmes de surveillance de la fréquence cardiaque peuvent être inexacts. Un exercice intensif peut entraîner des blessures graves ou la mort. Si vous ressentez une sensation de malaise, arrêter immédiatement l'exercice.
Conseils d'utilisation : <ul style="list-style-type: none"> • Obtenir un examen médical avant de commencer tout programme d'exercice. • Obtenir des instructions avant toute utilisation. • Lire et comprendre les étiquettes d'avertissement.  • Lire et comprendre les procédures d'arrêt d'urgence. • Le poids maximum de l'utilisateur ne doit pas dépasser 180 kg (400 lb). • Inspecter l'appareil. S'il est endommagé, en aviser le personnel. NE PAS UTILISER. • Placer vos pieds sur les deux premières marches lors du démarrage ou de l'arrêt du tapis roulant. • Clip E-STOP lanière aux vêtements. • Ne pas enlever cette étiquette. Remplacer si endommagé ou illisible.
Pendant l'utilisation : <ul style="list-style-type: none"> • Ne pas utiliser pour les étirements et ne pas attacher des sangles ou autres dispositifs. • Ne pas permettre aux enfants de 12 ans ou moins de rester près de la machine. • Arrêter l'exercice si vous ressentez une faiblesse, un étourdissement ou une douleur. • Utiliser des rampes de soutien pour maintenir l'équilibre. • Garder votre corps, vos vêtements et vos accessoires éloignés des pièces mobiles. • Attendre l'arrêt complet de la bande de roulement avant de descendre.
DE-24016-2 B

⚠ CAUTION
Moving parts hazard. To avoid injury, keep hands and fingers away when in use.
DE-18362-4 B

⚠ WARNING
Burn hazard. Do not touch flywheel until cool.
DE-18363-4 C

Label Placement - 770R

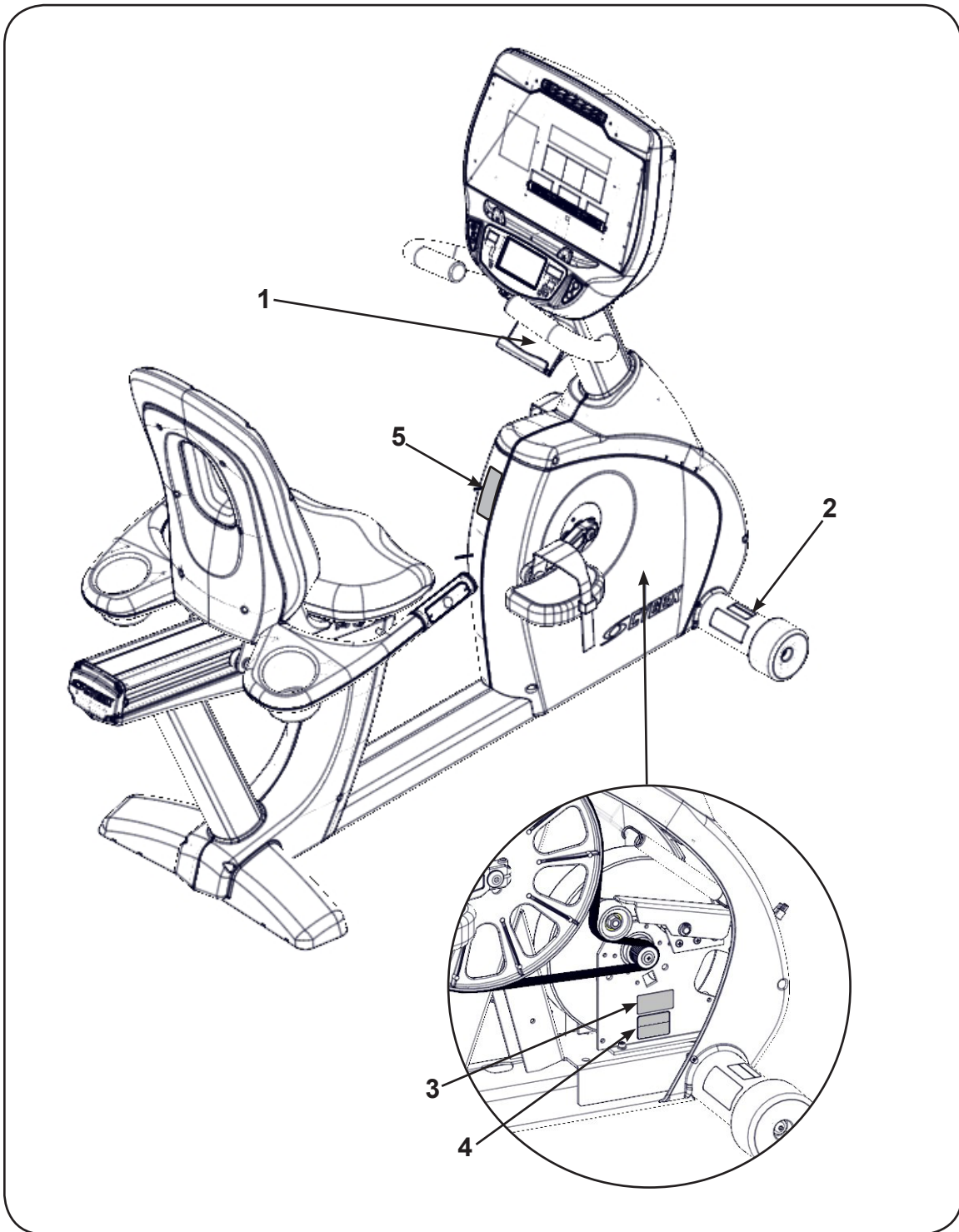

1	DE-23740-4	Label, Warning, Access tray,
2	DE-21749-4	Label, Warning, Disconnect Power
3	DE-18363-4	Label, Warning, Hot flywheel
4	DE-18362-4	Decal, Caution moving parts
5	DE-24016-2	Label, Warning, Canada

Assembly

Specifications

	770C Cycle	770R Cycle
Length:	48" (122 cm)	65" (165 cm)
Width:	22.5" (57 cm)	25" (64 cm)
Height:	64" (163 cm)	52" (132 cm)
Weight of Product:	142 lbs. (64 kg)	183 lbs. (83 kg)
Shipping Weight:	176 lbs. (80 kg)	231 lbs. (105 kg)
Resistance Levels:	21 (User selected in Manual or Bike Mode)	
Workouts:	Quick Start, four Weight Loss, five Cardio, two Power, and one Fitness Test. Quick Start is facility selectable as "Bike" mode or Constant Power. Weight Loss and Cardio workouts are constant power. Quick Start and Workouts have 21 levels.	
Console Features:	Graphic display: Profile via 8 x 15 LED matrix. Numeric display: Time, distance, calories, calories/hour, MET, watt, RPM, and heart rate including multi-color indication of heart rate range. Lower display shows road speed and resistance level.	
Heart Rate Features:	Built-in wireless heart rate receiver (transmitter not included) and contact heart rate monitoring.	
Resistance Range:	Minimum - 20 Watts; Maximum - 900 Watts.	
Maximum User Weight:	400 lbs. (181 kg).	
Power:	Self-powered or optional AC adapter for full time display.	
Power Supply:	100-240 V, 50/60 Hz, 1.0 A, AC (9V DC, 1.7A). NEMA 5-15 plug (TR-18231) or IEC-320 inlet (TR-18230).	
Other:	Water bottle holder and utility tray.	
Options:	Wireless audio receiver, E3 View monitor.	

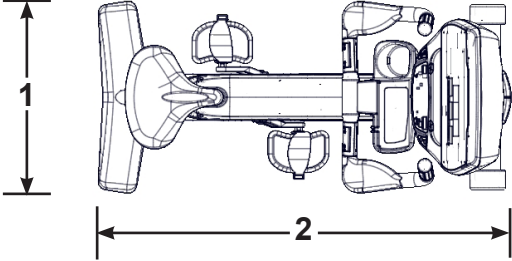
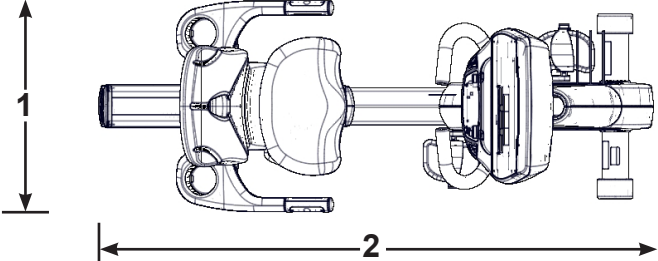
			
770C Cycle		770R Cycle	
1	22.5" (57 cm)	1	25" (64 cm)
2	48" (122 cm)	2	65" (165 cm)

Choosing and Preparing a Site

Before assembling the unit, verify the chosen site meets the following criteria:

- Area is well lit and well ventilated.
- Surface is structurally sound and properly leveled.
- Free area for access to unit and emergency dismount. Minimum clearance is 23.6 inches (0.6 meters).
- Adjacent units may share the free area.

It is the responsibility of the facility owner/owner of the equipment to ensure that there is appropriate clearance around each machine to allow for safe use and passage.

In compliance with the ADA (American Disabilities Act) there must be clear floor space of at least 30 by 48 inches and be served by an accessible route for at least one of each type of exercise equipment. If the clear space is enclosed on three sides (e.g., by walls or the equipment itself), the clear space must be 36 by 48 inches.

All other machines must have a clear floor space of 23" for all access point on the machine.

The dimensions stated in the assembly instructions of this manual include the maximum foot print (in use) dimensions.

- Area is not in the vicinity of high humidity, such as in the vicinity of a steam room, sauna, indoor pool or outdoors. This unit is designed to function normally in an environment with a relative humidity range of 30% to 75%.

Exposure to extensive water vapor, chlorine and/or bromine could adversely affect the electronics as well as other parts of the unit.

- Area maintains an ambient temperature range of 50° F (10° C) to 104° F (40° C) degrees.

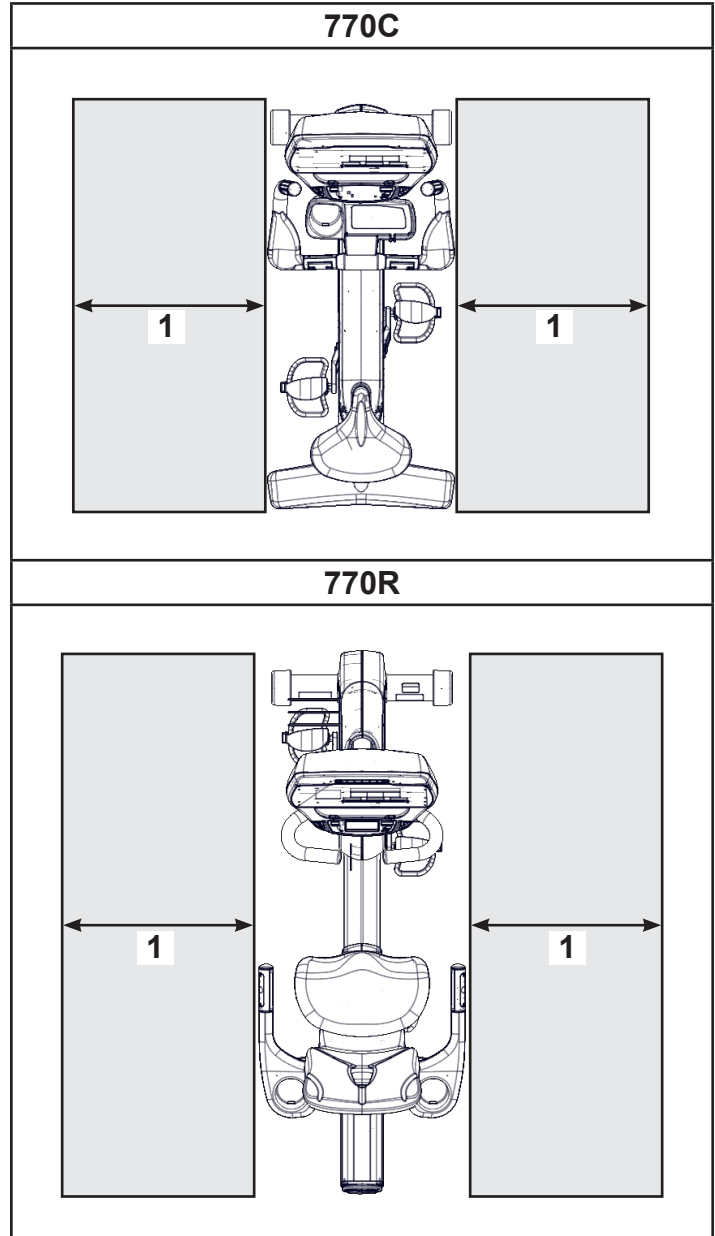

	Free area
1	23.6", 0.6m

Electrical Power Requirements

The AC power kit is optional.

Verify the unit is connected to an outlet having the same configuration as the plug.

Verify connection is a grounded circuit. Do not use a ground-plug adapter to adapt the 3-prong power cord to a non-grounded electrical outlet.

Use Cybex supplied AC power kit only. Consult an electrician with any questions.

Verify power supply is compliant with local building codes.

Unit Assembly

Tools Required

- 3/16" Allen wrench (supplied with 770R only)
- Phillips screwdriver
- 1/2" Socket wrench
- 9/16" Open end wrench

The words "left" and "right" denote the user's orientation.

Read and understand all instructions thoroughly before assembling the unit.

Verify correct package.

1. Read box label to verify the model number and voltage match what was ordered.
2. Lift and remove cardboard sleeve surrounding unit.
3. Verify paint color matches what was ordered.
4. Verify correct voltage by reading voltage sticker near power outlet. AC power kit is optional.

770C Assembly

Unpack and verify contents of boxes.

Verify the following items are present. See Customer Service chapter for contact information if any parts are missing.

Item	Quantity	Part Number	Description
1	1	Varies	Base with covers attached
2	1	Varies	Console assembly
3	1	PL-21584	Back Cap
4	1	PL-21581	Front Left Cover
5	1	PL-21582	Front Right Cover
6	1	PL-21583	Top Cap
7	1	AX-21698	Hardware pack
8	1	LT-23688-4	Owner's Manual
9	1	LT-23690	Assembly poster
10	1	LT-23693	Warranty sheet, Consumer
10	1	LT-23692	Warranty sheet, Commercial
11	1	Varies	Power cord (E3 View Monitor option)
12	1	AW-23836	Cable, 6', Coax (E3 View Monitor option)

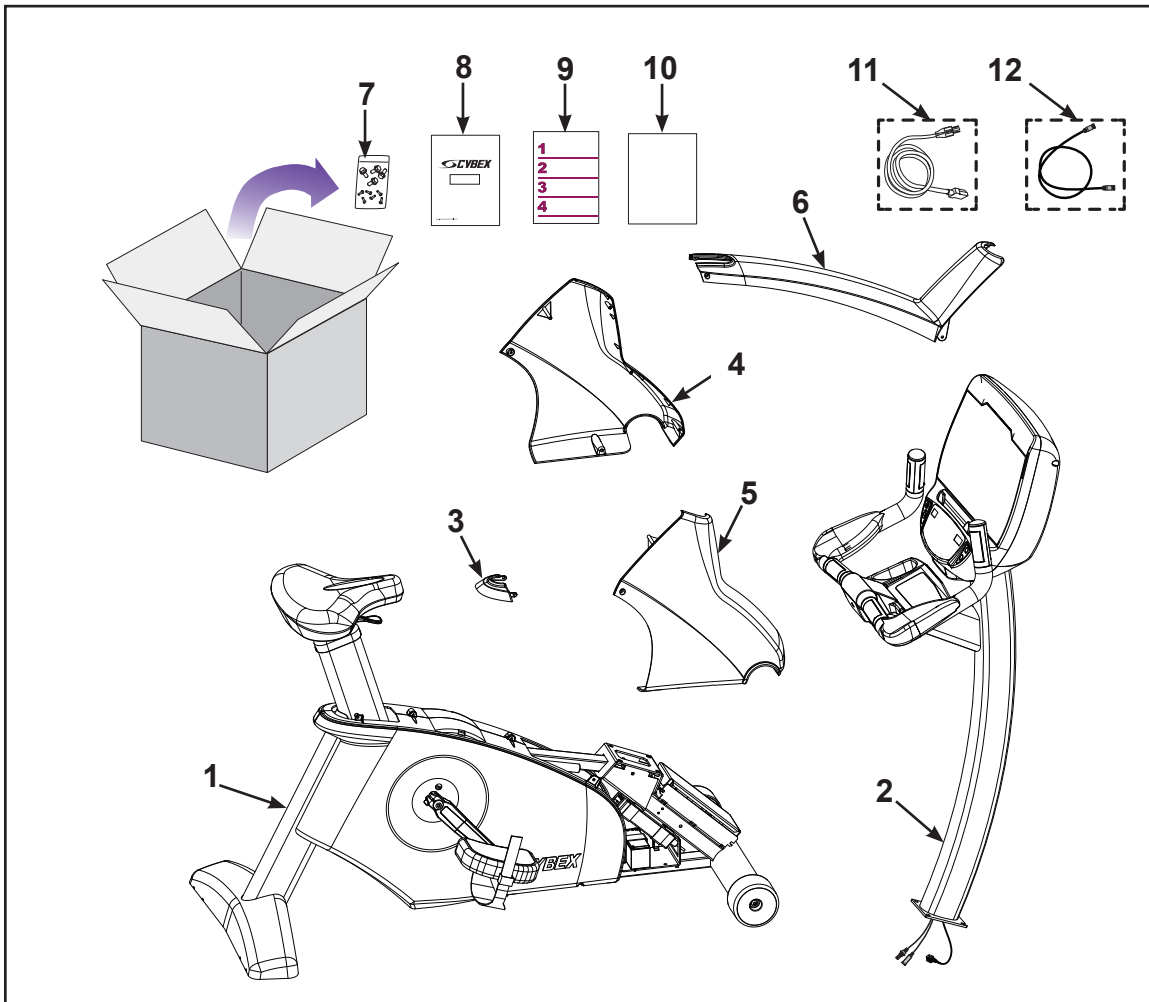

Item	Quantity	Part Number	Description
13	4	HS-19108	Screw, 5/16-18 x .75",HXHD,WHIZ-LOCK,GR5
14	6	HS-15706	Screw, 8-16 x .50", PNHD

Hardware

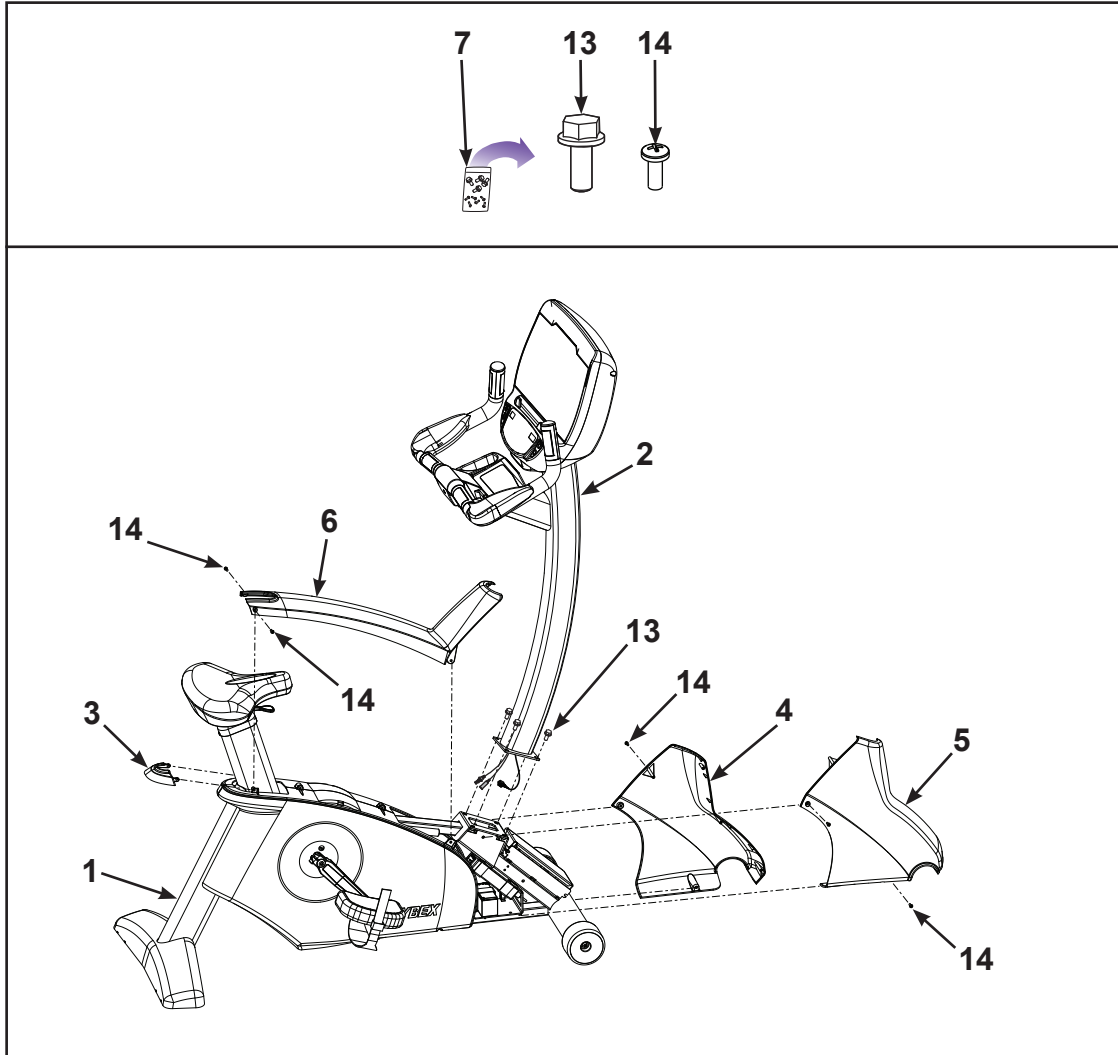

Lift and move the unit

1. Grasp the rear foot.
2. Lift the rear foot so the front transport wheels are able to roll on floor. Use proper lifting methods.
3. Roll unit to intended location.
4. Lower the rear foot so unit is in intended location.

Install console assembly to base assembly.

1. Hand thread two screws into the base assembly.

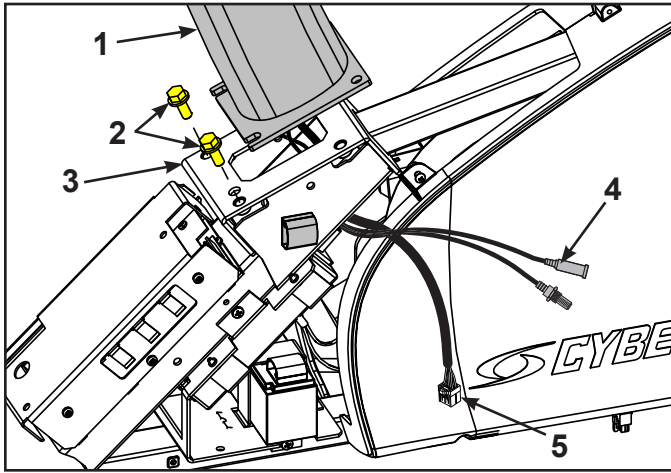

	Item	Description
1		Console Assembly
2	13	Screws (2)
3	1	Base Assembly
4		Optional A/V Cable
5		Display Cable

The console assembly will need to be supported during steps 2 through 5.

2. Insert the display cable and optional A/V cable through the frame to the left side. Do not pinch or damage the cables during assembly.
3. Place the console assembly in the correct position on the base assembly by sliding into position onto the two mounting screws.
4. Hand thread the other two screws.

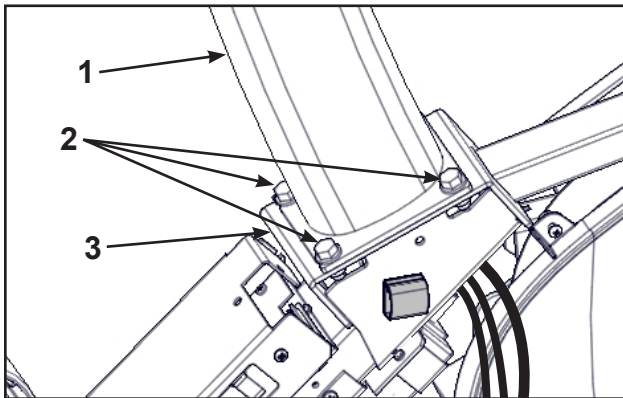

	Item	Description
1		Console Assembly
2	13	Screws (2)
3	1	Base Assembly

5. Securely fasten the four screws with a 1/2" socket wrench.

6. Route cables through gray clip on controller.

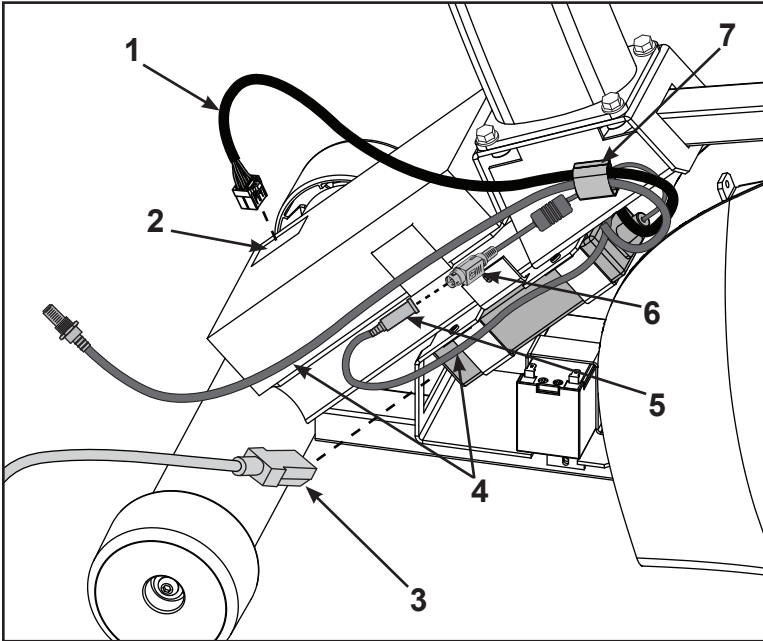

	Item	Description
1		Display Cable
2		Display Cable Connector
3	11	Power Cord
4		Optional A/V Cables
5		Console Cable DIN Connector
6		Power Supply Output
7		Gray Clip

7. Plug the display cable into the display cable connector on the lower control board. Ensure the cable connector is securely fastened.

8. Connect the console cable's DIN connector to the power supply output. Make sure the two connectors snap firmly together and can not be pulled apart without pulling the sleeve back to release it.

Install front covers.

1. Install front left cover with one screw using a Phillips screwdriver.

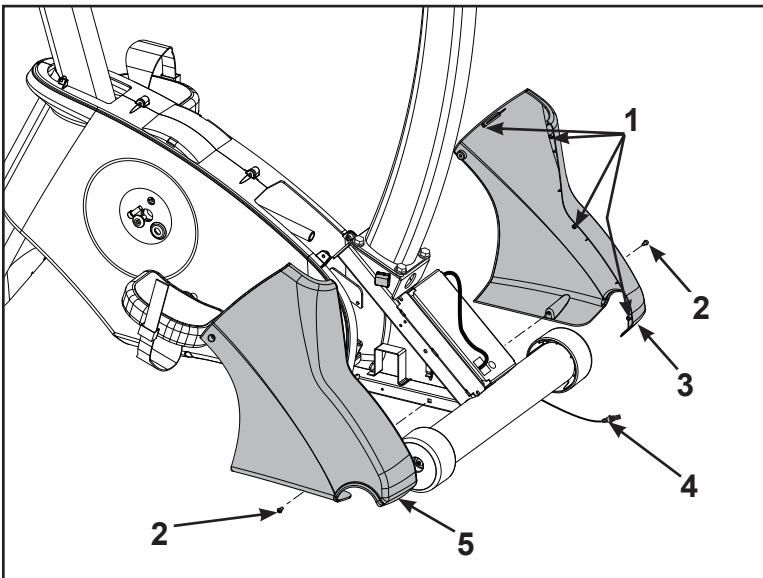

	Item	Description
1		Plastic Connectors
2	14	Screw
3	4	Front Left Cover
4		Optional A/V Cables
5	5	Front Right Cover

2. Route optional A/V cables through front covers to front of unit. Do not pinch or damage the cables during assembly.

In addition to the mounting screws, there are four plastic connectors that secure the front covers together. Ensure that all four plastic connectors are inserted properly in each front cover.

3. Install front right cover with one screw using a Phillips screwdriver.

Install top cap.

Install top cap with two screws using a Phillips screwdriver.

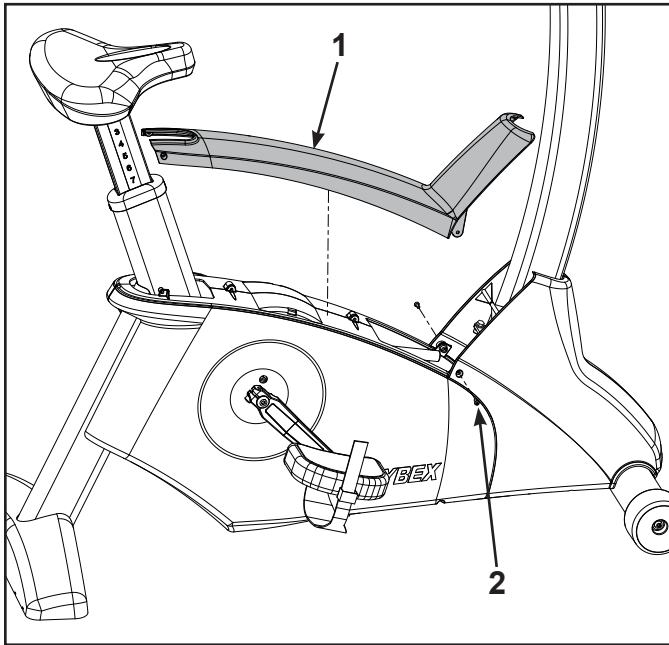

	Item	Description
1	6	Top Cap
2	14	Screws (2)

Install back cap.

1. Place the back cap into the top cap. Ensure the back cap is fully inserted into the top cap.

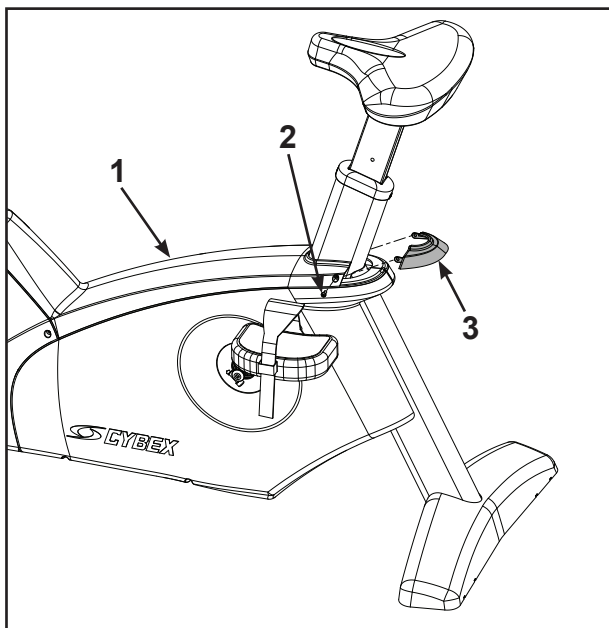

	Item	Description
1		Top Cap
2	14	Screws (2)
3	3	Back Cap

2. Install the back cap with two screws using a Phillips screwdriver.

Level the unit.

Confirm that the unit is on a level surface. If not, use a 9/16" open-end wrench to adjust the leveling feet up or down.

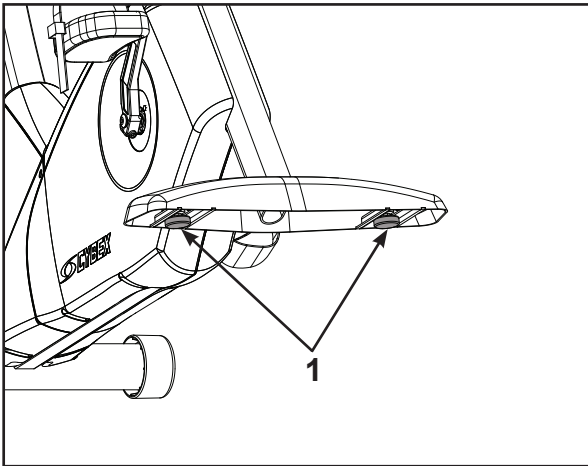

	Item	Description
1		Leveling Feet (2)

Install coax cable (E3 View Monitor option)

Install 6' coax cable to the coax cable connector in base of unit.

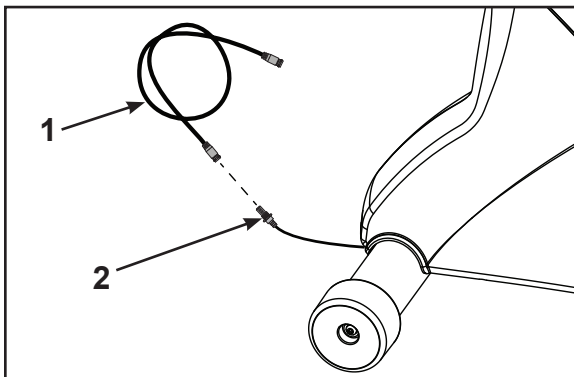

	Item	Description
1	12	6' Coax Cable
2		Coax Cable Connector

Visually inspect the unit.

1. Examine the unit to ensure that the assembly is correct and complete.
2. Proceed to *Testing the Operation* section.

770R Assembly

Unpack and verify contents of the unit.

Verify the following items are present. See Customer Service chapter for contact information if any parts are missing.

Item	Quantity	Part Number	Description
1	1	Varies	Base with covers attached
2	1	Varies	Console assembly
3	1	PL-21517	Front Left Cover
4	1	PL-21518	Front Right Cover
5	1	AX-21670	Seat Back Assembly
6	1	AX-21738	Accessory Tray
7	1	AX-21699	Hardware pack
8	1	LT-23688-4	Owner's Manual
9	1	LT-23691	Assembly poster
10	1	LT-23693	Warranty sheet, Consumer
10	1	LT-23692	Warranty sheet, Commercial
11	1	Varies	Power cord (E3 View Monitor option)
12	1	AW-23836	Cable, 6', Coax (E3 View Monitor option)

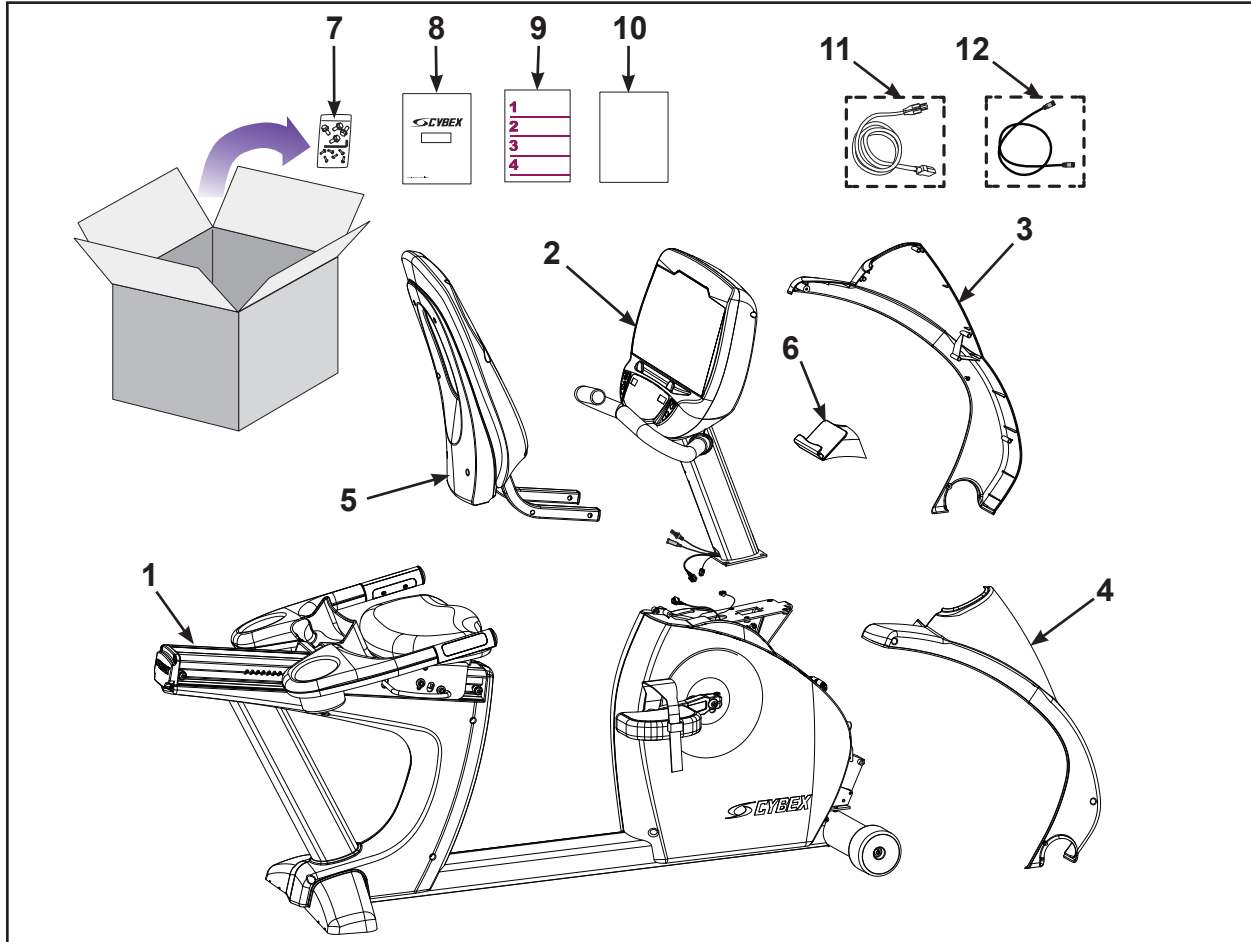

Item	Quantity	Part Number	Description
13	4	HS-19108	Screw, 5/16-18 x .75",HXHD,WHIZ-LOCK,GR5
14	4	HW-53018	Washer, 5/16" Split
15	4	HS-15706	Screw, 8-16 x .50", PNHD
16	2	HS-18311	Screw, 8-16 x .75", PNHD
17	4	HS-41107	Screw, 5/16-18 X 1.50"
18	1	HX-00438	3/16" Allen wrench

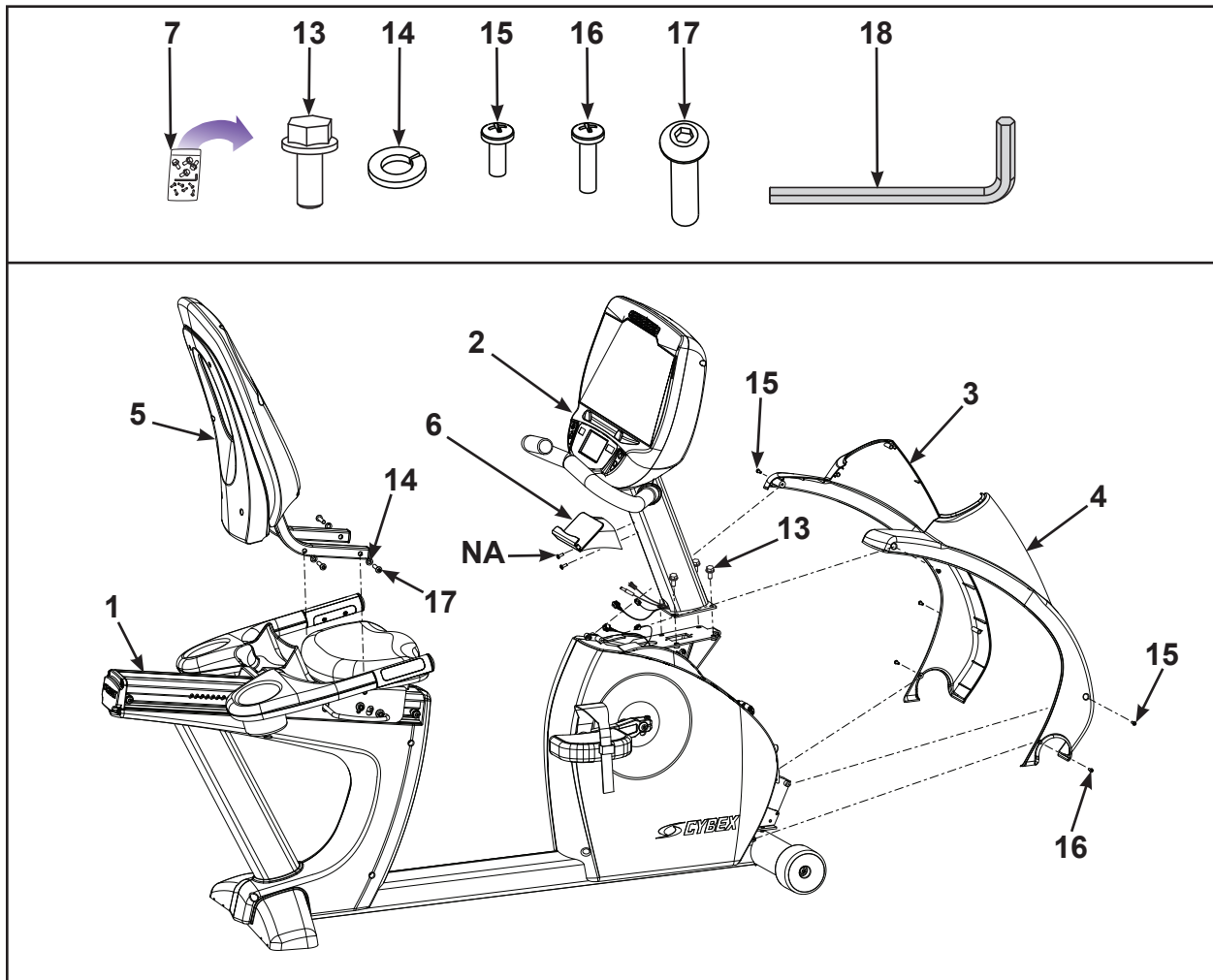

Lift and move the unit

1. Grasp the rear foot.
2. Lift the rear foot so the front transport wheels are able to roll on floor. Use proper lifting methods.
3. Roll unit to intended location.
4. Lower the rear foot so unit is in intended location.

Install seat back assembly.

1. Place the seat back assembly in the correct position and hand thread each of the screws and four washers.

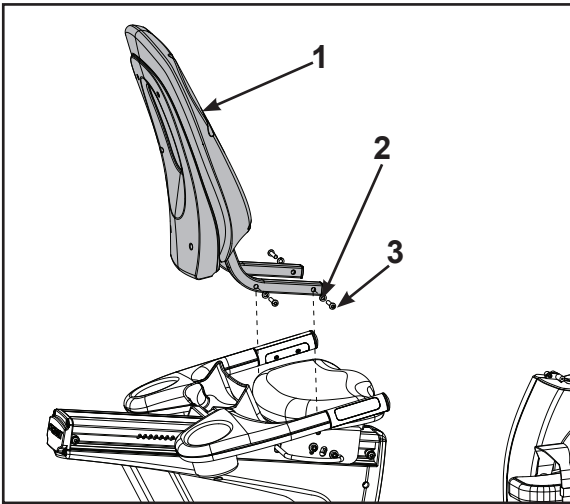

	Item	Description
1	5	Seat Back Assembly
2	14	Washers (4)
3	17	Screws (4)

2. Securely fasten the screws with the 3/16" Allen wrench provided.

Attach the console assembly to base assembly.

1. Hand thread two mounting screws into the base assembly.

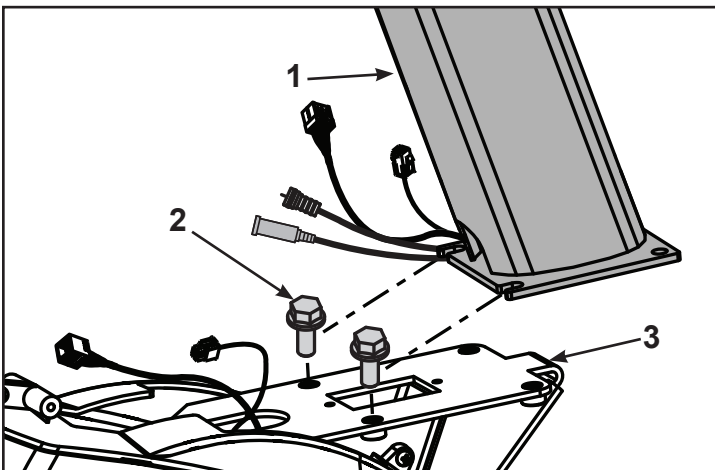

	Item	Description
1	2	Console Assembly
2	13	Screws (2)
3	1	Base Assembly

The console assembly will need to be supported during steps 2 through 4.

- Place the console assembly in the correct position on the base assembly by sliding into position onto the two mounting screws.

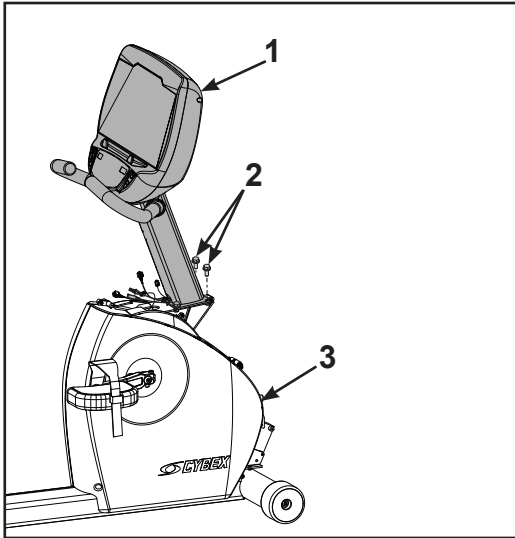

	Item	Description
1	2	Console Assembly
2	13	Screws (2)
3	1	Base Assembly

- Hand thread the other two screws.
- Securely fasten the four screws with a 1/2" socket wrench.
- Plug the upper display cable connector into the lower display cable connector. Ensure cable connectors click together and are securely fastened.

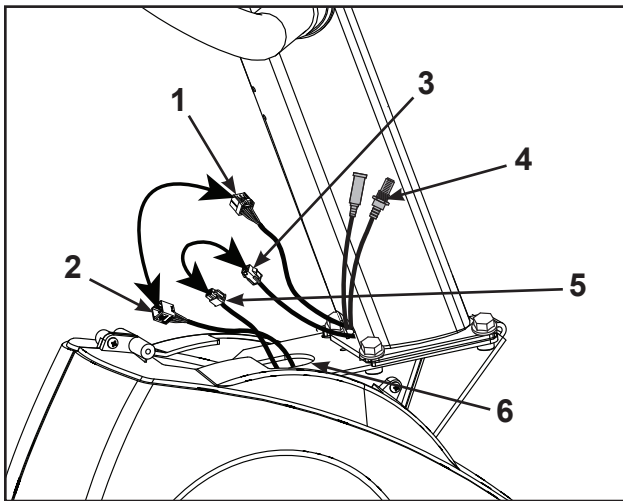

	Item	Description
1		Upper Display Connector
2		Lower Display Connector
3		Upper Heart Rate Connector
4		A/V Cables (optional)
5		Lower Heart Rate Connector
6		Top Hole In Frame

- Plug the upper heart rate connector into the lower heart rate connector.
- Tuck each of the cable connectors into the top hole in the frame. Do not pinch or damage the cables during assembly.

- Connect the console cable's DIN connector to the power supply output. Make sure the two connectors snap firmly together and can not be pulled apart without pulling the sleeve back to release it.

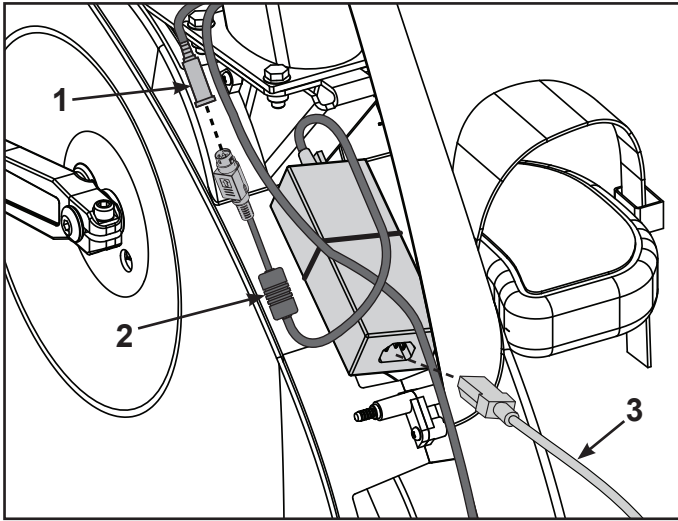

	Item	Description
1		Power Supply Output
2		Console Cable DIN Connector
3	11	Power Cord

Install the front covers.

- Install front right cover with three screws using a Phillips screwdriver.

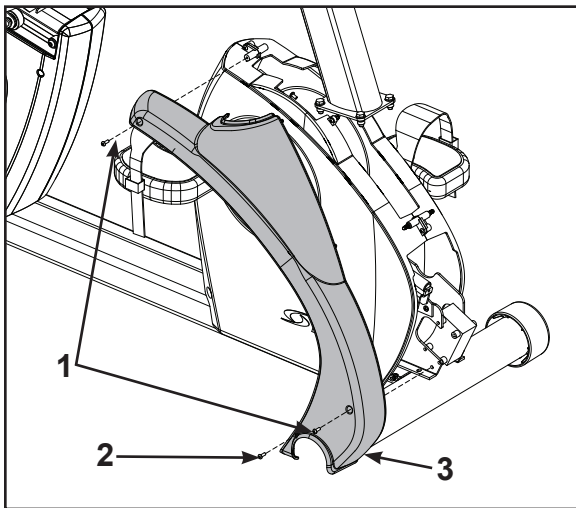

	Item	Description
1	15	Screw, 8-16 x .50" (3)
2	16	Screw, 8-16 x .75" (1)
3	4	Front Right Cover

In addition to three mounting screws per front cover, there are five plastic connectors that secure the front covers together. Ensure that all four plastic connectors are inserted properly in each front cover.

2. Install front left cover with three screws using a Phillips screwdriver.

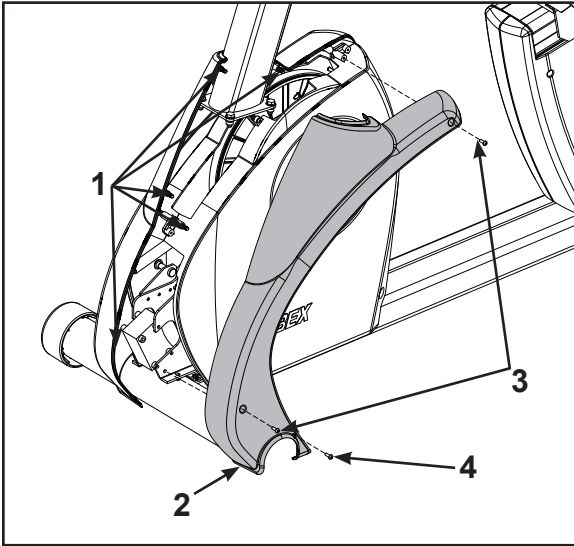

	Item	Description
1		Plastic Connectors
2	3	Front Left Cover
3	15	Screw, 8-16 x .50" (3)
4	16	Screw, 8-16 x .75" (1)

Install the accessory tray.

1. Remove the two screws in the console assembly using a Phillips screwdriver.

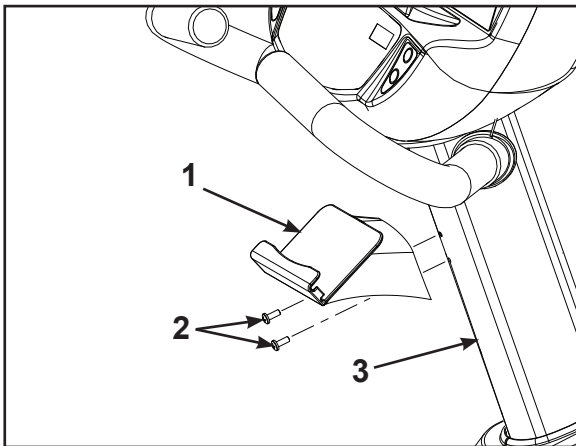

	Item	Description
1	6	Accessory Tray
2		Screws (2)
3	2	Console Assembly

2. Install the accessory tray to the console assembly with the two screws removed in previous step using a Phillips screwdriver.

Level the unit.

Confirm that the unit is on a level surface. If not, use a 9/16" open-end wrench to adjust the leveling feet up or down.

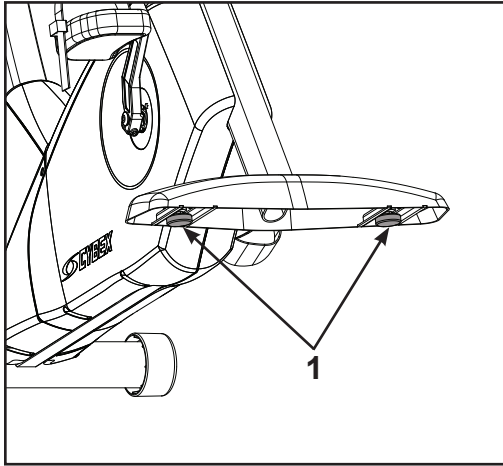

	Item	Description
1		Leveling Feet (2)

Install coax cable (E3 View Monitor option)

Install 6' coax cable to the coax cable connector in base of unit.

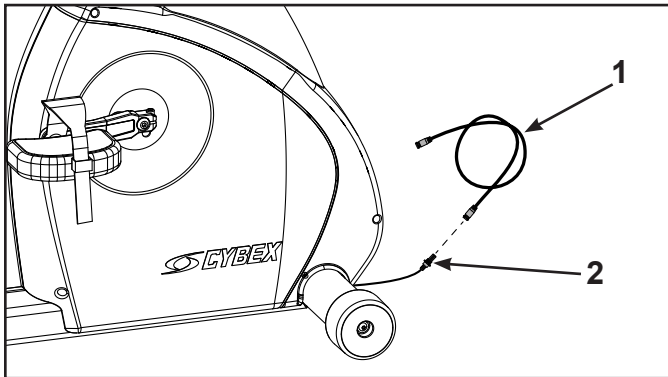

	Item	Description
1	12	6' Coax Cable
2		Coax Cable Connector

Visually inspect the unit.

1. Examine the unit to ensure that the assembly is correct and complete.
2. Proceed to *Testing the Operation* section.



Setup

Use the following instructions to setup the units settings.

1. Plug the optional power cord and E3 View Monitor power cord (E3 View Monitor units only) into a power outlet from a grounded circuit, See **Electrical Requirements**. Coil up the remainder of the power cord and place it out of the way. The control panel will light up and be in the Dormant Mode.
2. Hold the handrails to steady self while stepping into the pedals.
3. Begin pedaling.

Initial setup

Perform this procedure during the installation of the unit. Once complete, refer to Setup Options below.

	CYBEX LOGO	Press and hold Cybex logo for 6 seconds to access <i>Screen Lock</i> and <i>Toolbox</i> .
	LANGUAGE ICON	Press and hold language logo for 6 seconds to access <i>Screen Lock</i> and <i>Toolbox</i> .

1. Press the Access Toolbox icon to display the *Access to Toolbox* login screen.

2. Enter the sequence:     .

3. Press the Setup icon to display the *setup menu*.

4. Tap the **Time** icon to advance to the *Set the Time* screen.

5. Adjust the time if needed, then tap the **ENTER** icon .

6. Tap the **Date** icon to advance to the *Set the Date* screen.

7. Adjust the date if needed, then tap the **ENTER** icon .

8. Tap the **Units** icon to select the Set units preference screen.



9. Select the unit preferences from the following options:





Distance Units	Weight Units
Miles	Lbs.
Km	Kg.
	Stone

Exit Set Up Mode by tapping the **Toolbox** icon , then tap the **Home** icon . The screen will refresh.

Setup options

Enter setup options.

	CYBEX LOGO	Press and hold Cybex logo for 6 seconds to access <i>Screen Lock</i> and <i>Toolbox</i> .
	LANGUAGE ICON	Press and hold language logo for 6 seconds to access <i>Screen Lock</i> and <i>Toolbox</i> .

1. Press the Access Toolbox icon to display the *Access to Toolbox* login screen.
2. Enter the sequence:     .
3. Press the Setup icon to display the *setup menu*.

The Setup options are:

Time	Select Time Display option to On or Off. Add or subtract an hour. Select time display as AM, PM, or 24 Hour display. Enter time using keypad, press Enter icon to save.
Date	Select date style [MM] [DD] [YYYY], [DD] [MM] [YYYY], or [YYYY] [MM] [DD]. Y - Year, M - Month and D - Day. Enter date using keypad, press Enter icon to save.
Units and Power	Select distance units. MI - Miles or KM - Kilometers. Select weight units. LBS - Pounds, KG - Kilograms or Stone - Stones.
A/V Device (not shown for E3 View Monitor)	Select No TV or Wireless TV.
A/V Config (not shown for E3 View Monitor)	Active when A/V Device is set to Wireless TV. See <i>A/V Config</i> and <i>FM Radio Presets</i> below.
FM Radio Presets (not shown for E3 View Monitor)	Active when A/V Device is set to Wireless TV. See <i>A/V Config</i> and <i>FM Radio Presets</i> below.
PEM Setup	Active when A/V Device is set to Embedded TV. See <i>E3 View Monitor Controls</i> and <i>E3 View Monitor Setup</i> below.
Workout times	Set Default and Max workout times. Default choices are 20, 30, or 60 minutes. Max choices are 20, 30, 60, or OFF.
Pause	Set Pause time. Choices are OFF, 0:30, 1:00, or 2:00 minutes.
Sound	Console beeper: Choices are On, or Off. Headphone beeper: Some, all, or off. Default Volume: 1 to 31. Default is 10.
Language	Select default language to display on CardioTouch screen. Toolbox is only available in English. Include Optional Languages. Select optional languages to display on CardioTouch screen. Choices are Include or Off.
Restore Factory Defaults	Restores all setup variables back to factory defaults. Does not affect Time or Date.

Exit Set Up Mode

Exit Set Up Mode by tapping the **Toolbox** icon , then tap the **Home** icon . The screen will refresh.

A/V Configuration and FM Radio Presets

Setting up the Cybox Wireless Audio Receiver Module requires four steps:

- Determine the type of transmitter used (MYE 900MHz, Broadcast Vision 863MHz, etc. or TV FM).
- Set A/V Device to “Wireless TV”.
- Assign a TV channel number to each transmitter on the console.
- Add FM radio station presets (optional).

Accessories Required:

- Headphones (not included)

Determine transmitter type

There are two types of transmitters, UHF or TV FM. UHF transmitters will have TV's identified by number, example TV1. TV FM transmitters will have TV's identified with FM frequencies, example 93.1.

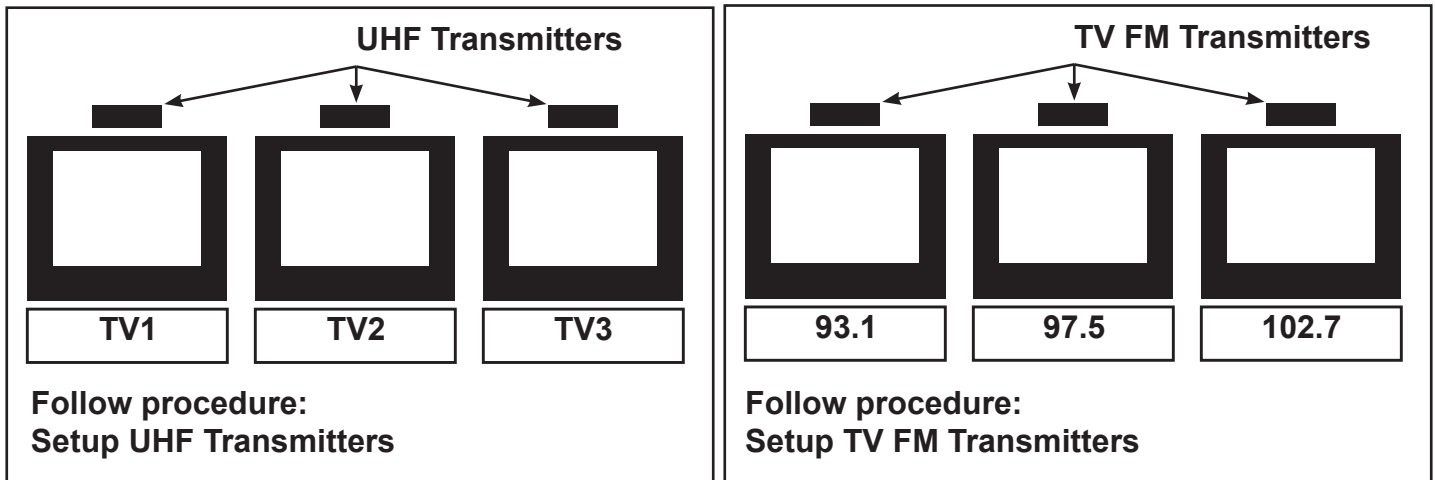









For TV FM transmitters, record FM frequencies for all TV's:

1	2	3	4	5	6	7	8	9	10

A/V setup mode

1. Plug the optional power cord into a power outlet from a grounded circuit, See **Electrical Requirements**. Coil up the remainder of the power cord and place it out of the way. The control panel will light up and be in the Dormant Mode.
2. Hold the handrails to steady self while stepping into the foot plates.
3. Begin striding.

	CYBEX LOGO	Press and hold Cybox logo for 6 seconds to access <i>Screen Lock</i> and <i>Toolbox</i> .
	LANGUAGE ICON	Press and hold language logo for 6 seconds to access <i>Screen Lock</i> and <i>Toolbox</i> .

4. Tap **Access Toolbox** to access the *Toolbox* login screen.
5. Enter the sequence:     .
6. Tap **Setup** at the main *Toolbox* screen.
7. Tap **Scroll Right**  to navigate to the **A/V Device** icon.
8. Tap **A/V Device**.
9. Tap **Device Installed** to select “Wireless TV” if not set.
10. Tap **Toolbox**  to return to the *Toolbox* screen.
11. Plug in headphones to listen for channels during setup.

Setup UHF Transmitters

For transmitter types 900 MHz, 863 MHz or 806 MHz. Use this procedure to associate channel numbers to your TV transmitters. If using an FM transmitter system, skip to Setup TV FM Transmitters.

Pick transmitter type

1. Tap **Setup** at the main *Toolbox* screen.
2. Tap **Scroll Right**  to navigate to the **A/V Config** icon.
3. Tap **A/V Config** to enter “TV Configuration”.
4. The display box will show the transmitter type. If your transmitter is not shown, tap **Select Xmtr** to toggle through the choices until your transmitter type is shown. If the display box is blank, there may be a problem with the embedded receiver, contact Customer Service.







900 MHz System	863 MHz System	806 MHz System
“M 900” MYE	“M 863” MYE	“J1 806” Japan 14 channels
“C 900” Cardio Theater	“E 863” Exercise	“J2 806” Japan 30 channels
“E 900” Exercise	“A 863” Audeon	
“B 900” Broadcast Vision		

5. Press **Scan** to scan for available channels. The scan can take up to 10 seconds and then display "TV-1 of #". The "#" symbol is total number of strong UHF channels found. Some of these channels may not be signals from the TV transmitters and need to be deleted.



If no TV numbers appear, no UHF transmitters were discovered. Verify the UHF transmitters are powered on and set to their respective TV numbers (1,2,3, etc.) or toggle the Near/Far setting and re-scan.

Review channels



1. Tap **Up**  or **Down**  to listen to available channels with the headphones.
2. Delete unwanted channels by pressing **Delete** to delete channel. Repeat process for additional unwanted channels.
3. Tap **Up**  or **Down**  to scroll through and verify all TV channels. If all TV transmitters are stored, and they all correlate the TV number to the correct TV heard, setup is complete. If all channels did not show up in the scan as expected, toggle the Near/Far setting and re-scan the transmitter codes (see documentation for your transmitters to perform a code change.)
4. Tap **Toolbox**  then **Home**  to exit setup. Transmitter setup complete.
5. Press **Show All** to confirm the TV numbers correspond to the frequencies entered.
6. Proceed to *Add FM Radio Stations (optional)*.

Setup TV FM Transmitters



If your TV's use FM transmitters, follow these instructions to assign a TV channel to each frequency.

1. Tap **Setup** at the main *Toolbox* screen.
2. Tap **Scroll Right**  to navigate to the **A/V Config** icon.
3. Tap **A/V Config** to enter **TV Configuration**.
4. Tap **Select Xmtr** to select your transmitter type as "TV FM".

Enter TV channels using one of the following procedures



- Tap **Seek** to seek the next TV FM frequency or **Up**  or **Down**  to tune manually. Press **Add** to store channel.
- Tap the keypad numbers to enter known channel, Press **Enter** and **Add** to store channel.









5. Repeat procedure to add all TV FM channels.
6. Press **Toolbox**  then **Home**  to exit setup when all the TV's FM transmitter frequencies have a TV number. Transmitter setup complete.
7. Proceed to *Add FM Radio Stations (optional)*.



Add FM Radio Stations (optional)

If strong local FM Radio Stations are available in the area, you can set those as presets.





	CYBEX LOGO	Press and hold Cybox logo for 6 seconds to access <i>Screen Lock</i> and <i>Toolbox</i> .
	LANGUAGE ICON	Press and hold language logo for 6 seconds to access <i>Screen Lock</i> and <i>Toolbox</i> .

1. Tap **Access Toolbox** to access the *Toolbox* login screen.
2. Enter the sequence:     .
3. Tap **Setup** at the main *Toolbox* screen.
4. Tap **Scroll Right**  to navigate to the **FM Radio Presets** icon.
5. Tap **FM Radio Presets** to display **FM Radio Presets** on the console.

Enter FM radio channels using one of the following procedures





- Tap **Seek** to seek the next FM radio frequency or **Up**  or **Down**  to tune manually. Tap **Add** to store channel.
- Tap the keypad numbers to enter known channel, Press **Enter** and **Add** to store channel.







1. Repeat procedure to save up to 32 FM radio stations.
2. Tap **Next**  or **Previous**  to scroll through and verify all FM radio stations.
3. Press **Show All** to to confirm the radio station numbers correspond to the frequencies entered.
4. Tap **Toolbox**  then **Home**  to exit setup when all FM radio stations are stored.

Adjust sound volumes

After completing the channel setup, it may be necessary to adjust the volume level of each TV so they all have similar volume levels. Since the FM Radio station volume can not be adjusted, this will be used as a 'base line' volume to adjust the TV's to.

1. Plug headphones into headphone jack.
2. Begin striding and press the **QUICK START** icon.
3. Press the **TV** icon.
4. Tap **Next**  or **Previous**  to select an FM radio station. This volume is not adjustable and is the base volume.
5. Tap **Up**  or **Down**  to select a TV station.
6. Adjust the volume of each TV to match an FM Radio Station or each other using the TV's remote control. The goal is for a volume setting of 10 on the unit to be the same for all TV and FM channels.
7. Repeat procedure for all TV's.

Using the Cybex Wireless Audio Receiver













1. Plug headphones into headphone jack.
2. Begin striding and press the **QUICK START** icon.
3. Tap the TV icon to listen to TV channels. Press the FM icon to listen to FM radio channels.
4. Tap **Next**  or **Previous**  to change TV or FM channels.
5. Tap volume **Up**  or **Down**  to adjust volume.

E3 View Monitor Controls

The CardioTouch screen is used to perform all setup operations for the E3 View Monitor.











CardioTouch screen functions

	Wrench Icon	Return to Toolbox home
	Up	Go to Setup home screen
	Next	Moves forward in Setup menu to next screen
	Default Display Mode	Select TV + Data, TV Only or Data Only
	On/Off	Turn the E3 View Monitor on or off
	Reset Defaults	Reset the setup values and clear all programmed channels.
	CH List	List all available channels
	Setup	Toggles the setup menu
	Navigate up	Navigate up through the on-screen menu
	Navigate down	Navigate down through the on-screen menu
	Navigate left	Decrease value
	Navigate right	Increase value

E3 View Monitor Setup

Access Setup Screen

	CYBEX LOGO	Press and hold Cybex logo for 6 seconds to access <i>Screen Lock</i> and <i>Toolbox</i> .
	LANGUAGE ICON	Press and hold language logo for 6 seconds to access <i>Screen Lock</i> and <i>Toolbox</i> .

1. Tap the **Access Toolbox** icon to display the *Access to Toolbox* login screen.
2. Enter the sequence:     .
3. Tap the **Setup** icon to display the *setup menu*.
4. Tap the **Shift Right**  icon to navigate to the **EPEM Setup** icon.
5. Tap the **EPEM Setup** icon.
6. Tap the **Setup**  icon to advance to the SETUP MODE screen on the E3 View Monitor. Follow procedure to setup the E3 View Monitor.

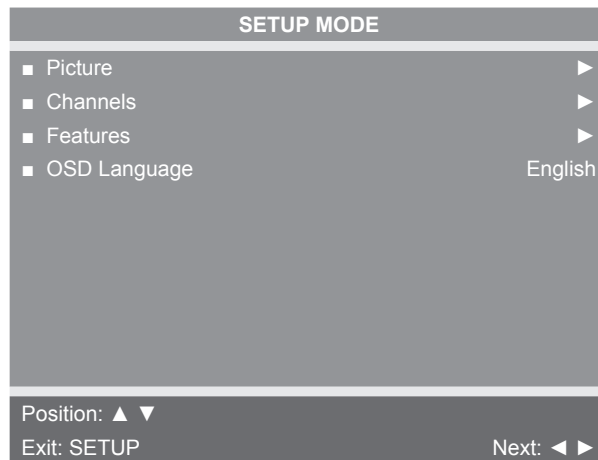

Picture

1. Tap ▲ or ▼ to select **Picture**.
2. Tap ► to select access **Picture** menu.

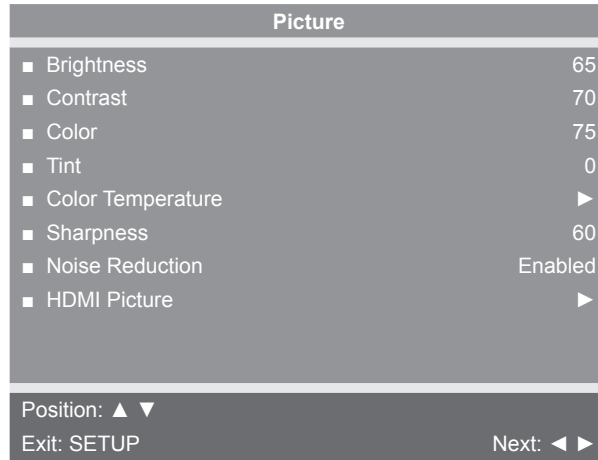

3. Tap ▲ or ▼ to select settings.
4. Tap ◀ or ▶ to adjust settings.

Picture settings

Brightness	Adjust range from 1 to 100. Default is 65.
Contrast	Adjust range from 1 to 100. Default is 70.
Color	Adjust range from 1 to 100. Default is 75.
Tint	Adjust range from 1 to 100. Range is R50 to G50. Default is 0.
Color Temperature	Adjust color balance of Red, Green and Blue temperatures.
Sharpness	Adjust range from 1 to 100. Default is 60.
Noise Reduction	Select Enabled (Default) or Disabled.
HDMI Picture	Set to Auto or Adjust settings as needed. Available only when HDMI signal is present.

5. Tap the **Setup**  icon to return to SETUP MODE menu.

Channels

1. Tap ▲ or ▼ to select **Channels**.
2. Tap ► to select access **Channels** menu.

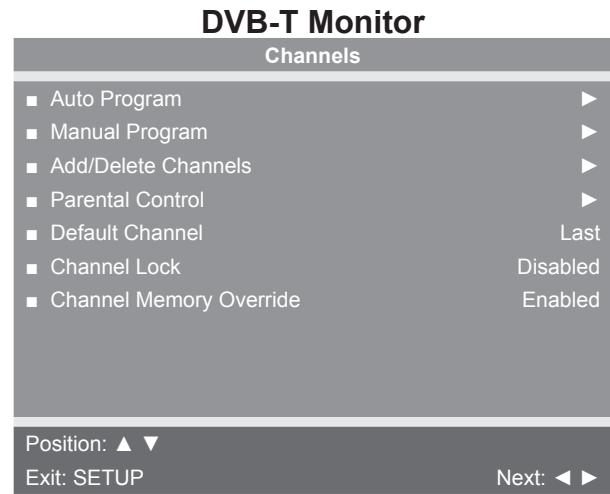
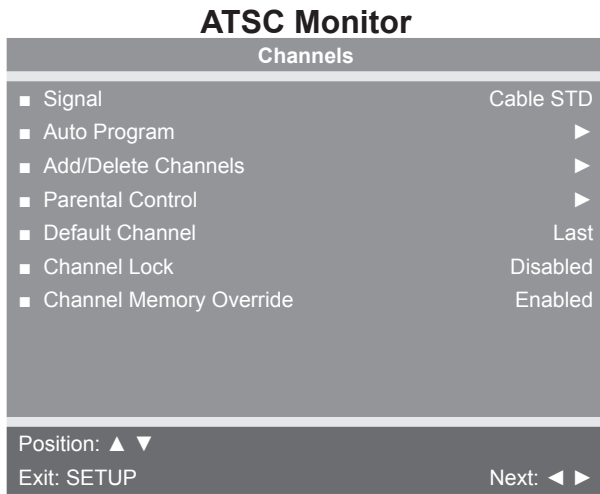

3. Tap ▲ or ▼ to select settings.
4. Tap ◀ or ▶ to adjust settings.

Channel settings

Signal (ATSC only)	Select Air, Cable STD, Cable IRC, or Cable HRC.
Auto Program	<i>See Below</i>
Manual Program (DVB-T only)	<i>See Below</i>
Add/Delete Channels	<i>See Below</i>
Parental Control	Block channels based on TV ratings.
Default Channel	Select channel to display on power up. Select from available channels or last.
Channel Lock	Select Enabled or Disabled. If enabled only one channel is shown, user cannot change channels.
Channel Memory Override	Select Enabled or Disabled. If enabled allows user to select any available channel.

Auto Program (ATSC Monitor)

1. Tap ▼ to select **Auto Program**.
2. Tap ► to enter the menu.
3. Tap ▲ or ▼ to select **Mode**.

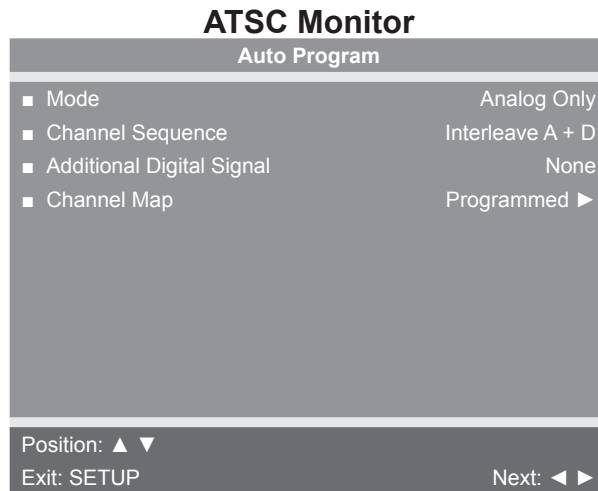

4. Tap ◀ or ► to set the scope of channel scanning.

- Analog Only (Default): TV searches for analog channels only.
- Digital Only: TV searches for digital channels only.
- Analog and Digital: TV searches for both analog and digital channels.

5. Tap ▼ to select **Channel Sequence**.

6. Tap ◀ or ► to set the Channel Sequence in which the channels are displayed after searching.

- Interleave A+D: In the order of channel number regardless of the system.
- All A then D: Digital channels are displayed after all analog channels.

7. Tap ▲ or ▼ to select **Additional Digital Signal**. Not available when **Mode** is set to Analog Only.

8. Tap ◀ or ► to choose the **Additional Digital Signal** source. Choices are: None, Air, Cable STD, Cable IRC, or Cable HRC.

9. Tap ▼ to select **Channel Map**.

10. Tap ► to start auto programming. A confirmation menu will appear before proceeding.

11. Tap ▲ (Yes) to start auto programming. Tap ▼ (No) button to cancel the operation. The TV will now search all available channels with an on-screen progress percentage displayed. Any tuning Mode that includes Digital channels will require several minutes to complete auto programming.

This may take 20 or more minutes. If screen shuts off, tap the  icon to turn monitor on.

12. Tap the **Setup**  icon to return to normal TV viewing once auto programming is complete.

13. Tap the  icon to list programmed channels.

14. Tap the **Setup**  icon to return to SETUP MODE menu.

Auto Program (DVB-T Monitor)

1. Tap ▼ to select **Auto Program**.
2. Tap ► to enter the menu.
3. Tap ▲ or ▼ to select **Country**.

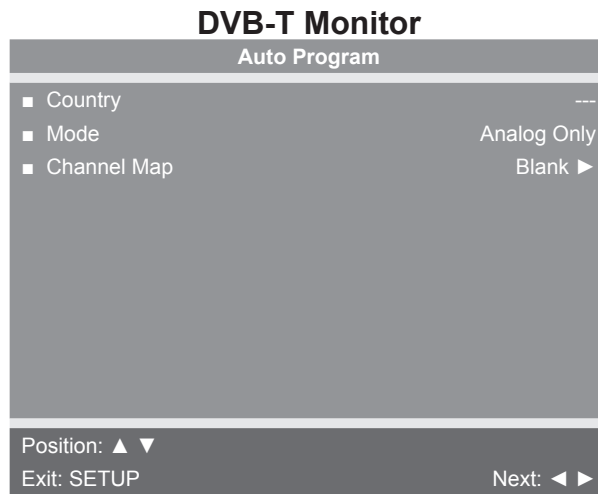

Available countries are:



Albania, Austria, Australia, Belgium, Bosnia, Bulgaria, China, Croatia, Czech, Denmark, Estonia, Finland, France, Germany, Greece, Hungary, Ireland, Italy, Kazakhstan, Latvia, Lithuania, Luxembourg, Morocco, Netherlands, Norway, Poland, Portugal, Romania, Russia, Serbia, Slovakia, Slovenia, Spain, Sweden, Switzerland, Turkey, Uk, and Ukraine.

4. Tap ▲ or ▼ to select **Mode**.
5. Tap ◀ or ► to set the scope of channel scanning.

- Analog Only (Default): TV searches for analog channels only.
- Digital Only: TV searches for digital channels only.
- Analog and Digital: TV searches for both analog and digital channels.

6. Tap ▼ to select **Channel Map**.
7. Tap ► to start auto programming. A confirmation menu will appear before proceeding.
8. Tap ▲ (Yes) to start auto programming. Tap ▼ (No) button to cancel the operation. The TV will now search all available channels with an on-screen progress percentage displayed. Any tuning Mode that includes Digital channels will require several minutes to complete auto programming.

This may take 20 or more minutes. If screen shuts off, tap the  icon to turn monitor on.

9. Tap the **Setup**  icon to return to normal TV viewing once auto programming is complete.
10. Tap the **CH List**  icon to list programmed channels.
11. Tap the **Setup**  icon to return to SETUP MODE menu.

Manual Program (ATSC and DVB-T)

1. Tap ▼ to select **Manual Program**.
2. Tap ► to enter the menu.
3. Tap ▲ or ▼ to select **Mode**.

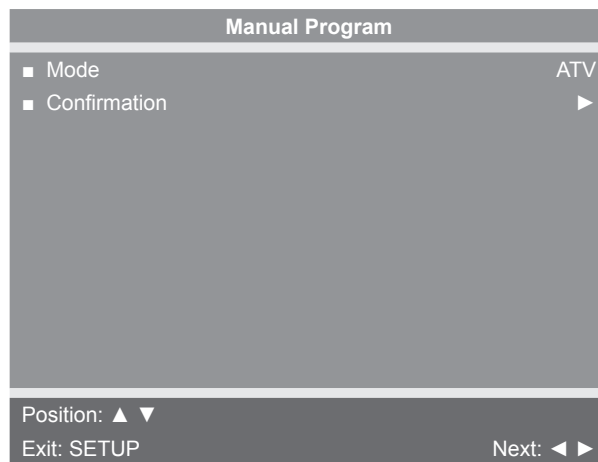

4. Tap ◀ or ▶ to select ATV or DTV.

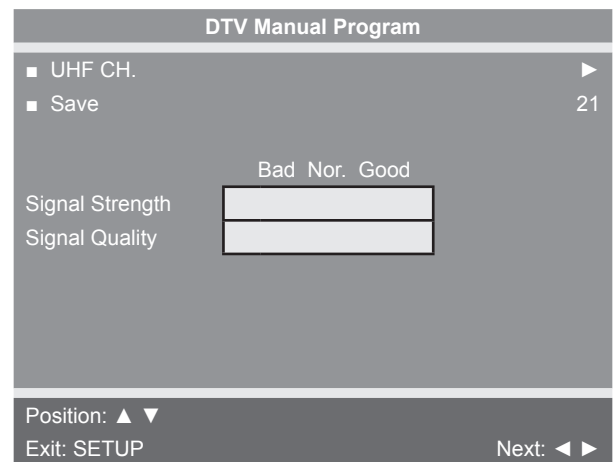
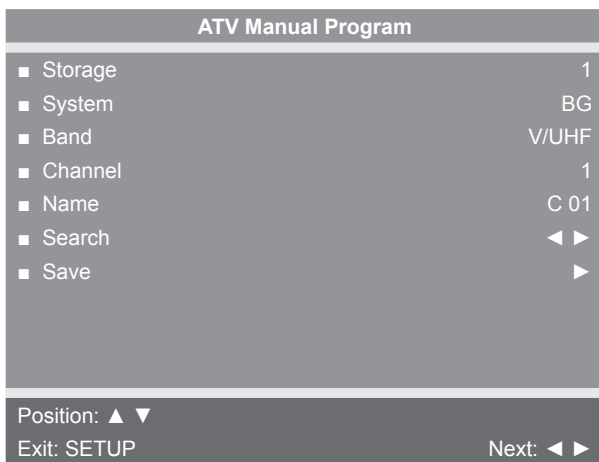



ATV Mode	Adjust settings for Storage, System, Band, Channel, Name, or Search. Select Save to save settings.
DTV Mode	Select UHF channel. Select Save to save settings.

Add/Delete Channels (ATSC and DVB-T)

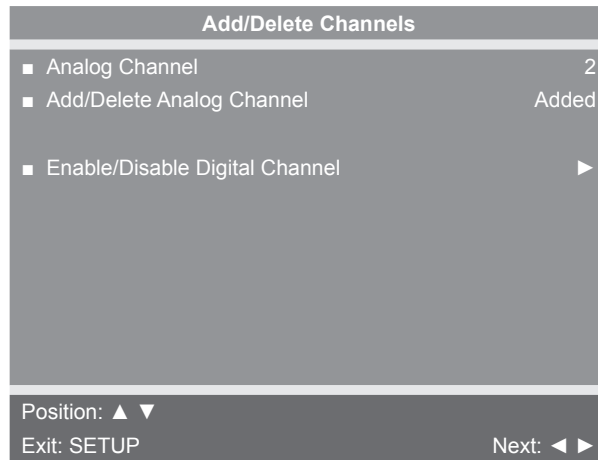
1. Tap ▼ to select **Add/Delete Channels**.
2. Tap ► to enter the Add/Delete Channels menu.



To add or delete an analog channel perform the following procedure. To enable or disable digital channels, go to step 7.

3. Tap ◀ or ▶ to select the desired analog channel.
4. Tap ▲ or ▼ to highlight **Add/Delete Analog Channel**.
5. Tap ◀ or ▶ to select **Added** or **Deleted**.
6. Tap the **Setup**  icon to return to the previous menu. To exit, Tap the **Setup**  icon until the programming menus disappear. If there are more analog channels to be added or deleted, repeat steps 3 through 5.
7. Tap ▲ or ▼ to highlight **Enable/Disable Digital Channel**.
8. Tap ► to select **Enable/Disable Digital Channel**. If there are not any channels programmed in the Service Level, “No Channels Present” will appear in the menu.
9. Tap ▲ or ▼ to highlight the digital channel that needs to be enabled or disabled.
10. Tap ◀ or ▶ to select **Enable** or **Disable**.
11. Tap the **Setup**  icon to return to the previous menu.

Features

1. Tap ▲ or ▼ to select **Features**.
2. Tap ► to select access **Features** menu.

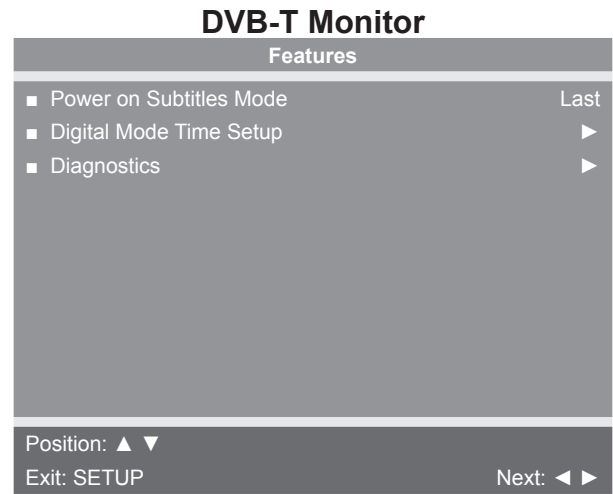
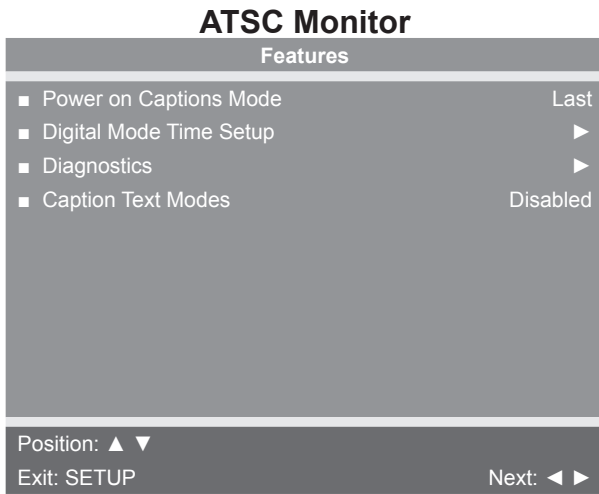

3. Tap ▲ or ▼ to select settings.
4. Tap ◀ or ▶ to adjust settings.

Feature settings

Power on Captions Mode (ATSC only)	Select Off or Last. Last will set caption mode to last used setting.
Power on Subtitles Mode (DVB-T only)	Select Off or Last. Last will set subtitle mode to last used setting.
Digital Mode Time Setup	Set current time automatically from digital signal. Select time zone and daylight savings time to Auto, On, or Off.
Diagnostics	Provides diagnostic information only. Settings cannot be changed.
Caption Text Modes (ATSC only)	Select Enabled or Disabled.

5. Tap the **Setup**  icon to return to SETUP MODE menu.

OSD Language

1. Tap ▲ or ▼ to select **OSD Language**.
2. Tap ◀ or ▶ to select language.

ATSC choices	English, Français or Español.
DVB-T choices	English, Français, Español, Dutch, Danish, Russian, German, and Swedish.

3. Tap the **Setup**  icon to return to SETUP MODE menu.

Exit Set Up Mode by tapping the **Toolbox** icon , then tap the **Home** icon . The screen will refresh.

Setup Complete

Testing the Operation

Use the following instructions to test the full resistance range of the unit:

1. Plug the optional power cord into a power outlet from a grounded circuit, See **Electrical Requirements**. Coil up the remainder of the power cord and place it out of the way. If you do not have the optional power supply, skip to step 3.
2. Verify the control panel will illuminate and is in *Dormant Mode*.
3. Hold the handrails to steady self while stepping into the pedals.
4. Begin pedaling.
5. Tap **QUICK START** icon on the CardioTouch screen.
6. Run unit through full resistance range. First press the **RESISTANCE +** key until unit reaches its highest load (the display will show “21”). Then press the **RESISTANCE -** key until unit reaches its lowest load (the display will show “1”). The resistance should increase and decrease while pedaling.

When unit reaches the set resistance, the displays will stop flashing and remain steadily illuminated to indicate the desired setting has been reached.

7. Wait until pedals come to a complete stop before dismounting the unit. Hold the handrails to steady self while stepping off the unit.

Operation

Intended Use

The intended use of this exercise equipment is to aid or improve general physical fitness and exercise.

Terms Used

Active Mode – Any time the unit is controlling resistance and accumulating workout data. Active Mode begins after tapping **QUICK START** icon during the initial count-down screen, after completing the setup for a workout, or by default if the initial count-down screen times out and enters Quick Start mode.

Auto-Scan – Display automatically cycles through workout data.

Bike Mode – Control the gear used from 1 to 21. Gear 1 is very easy to pedal at slow road speed, gear 21 is very hard to pedal at high road speed.

CardioTouch Screen – The CardioTouch Screen is the touch screen located at the bottom of the console.

Constant Power Mode – Control the brake power from 35 to 500 Watts. The bike will decrease the resistance at higher speeds or increase resistance at slower speeds. The bike will maintain a constant power setting.

Cool Down – A reduction of work load for a short duration allows user to gently reduce heart rate. Cool Down occurs two minutes prior to completion of the workout session.

Dormant Mode – Occurs when unit is not in use.

Isokinetic Exercise – Accommodating resistance, where unit provides a corresponding amount of resistance on the user to keep them at a fixed pedal speed. Such exercise is used to test and improve muscular strength and endurance, especially after injury.

Manual Mode – User has full control of the workout which ends at the selected goal.

Pause Mode – Pause the workout. Pause time remaining will count-down on the display.

Workout Type – A collection of workouts with a common theme.

Quick Start – Tap the **QUICK START** icon to enter into Quick Start Mode. User has full control over the workout as time counts up.









Workout Review – At the end of each workout, the console will display the total session time, accumulated calories and distance, or the results of the fitness test.



Read and understand all warnings and cautions in the Safety Section and all operation instructions in this chapter before operating unit.

User Control Symbols Used











Control	Control Name	Description
	RESISTANCE UP	Increase Bike Gear (1-21), Power (35-500) or Target RPM (20-100).
	RESISTANCE DOWN	Decrease Bike Gear (1-21), Power (35-500) or Target RPM (20-100).
	VOLUME UP	Adjust Volume up.
	VOLUME DOWN	Adjust Volume down.
	CHANNEL/TRACK CONTROL	Adjust Time, Level, Weight, or Workout up. iPod - NEXT track. A/V - Channel UP .
	CHANNEL/TRACK CONTROL	Adjust Time, Level, Weight, or Workout down. iPod - PREVIOUS track. A/V - Channel DOWN .
	STOP	Ends the workout session and shows the Workout Review.
	FAN	Default speed is OFF during active mode. Press the FAN key to control fan speed. Choices are OFF, LOW and HI.

CardioTouch Symbols Used

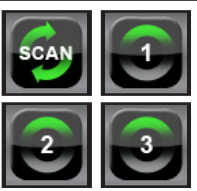

Icon	Icon Name	Description
	QUICK START	<i>Quick Start</i> enters <i>Active Mode</i> at the default resistance with time counting up from 0:00.
	WORKOUTS	Tap <i>Workouts</i> icon to enter workout group selection.
	TV	Tap <i>TV</i> icon to enter TV control menu. If TV is not connected, icon will not be shown.
	TV + FM	Tap <i>TV + FM</i> icon to enter TV + FM control menu. If TV + FM is not connected, icon will not be shown.
	iPOD	Tap <i>iPod</i> icon to enter iPod control menu. If iPod is not connected, icon will be grayed out.
	HOME	Return to opening screen.
	START	Enter <i>Active Mode</i> .
	PAUSE	If pause feature is enabled, pause icon is shown. Press pause icon once to enter pause mode.
	STOP	If pause feature is disabled, stop icon is shown. Press stop icon or STOP button once to enter "Workout review".
	BACK	Return to previous or opening screen.
	UP LEVEL	Go up one level or return to iPod screen.

Icon	Icon Name	Description
	SHIFT LEFT	Shift the screen left to view more options.
	SHIFT RIGHT	Shift the screen right to view more options.
	KEYPAD	Numeric keypad for entering data.
	ENTER	Accepts the value shown.
	CLEAR	Clear any values selected.
	INFO	Select to provide more information and details.
	SCALE	Displays current value in the minimum and maximum range.
	SCAN	This icon defaults to SCAN, which displays the workout info on the upper display, changing every 5 seconds. Tap the SCAN icon to display different data sets. Tap again to change the data set, or multiple times to get back to SCAN.
	CYBEX LOGO	Press and hold Cybox logo for 6 seconds to access <i>Screen Lock</i> and <i>Toolbox</i> .
	LANGUAGE ICON	Tap language icon to select available languages. Set languages available in Setup Options section. Press and hold language logo for 6 seconds to access <i>Screen Lock</i> and <i>Toolbox</i> .

Console Display

The 770C and 770R models have two display options, LED or E3 View Monitor shown below.

LED Display

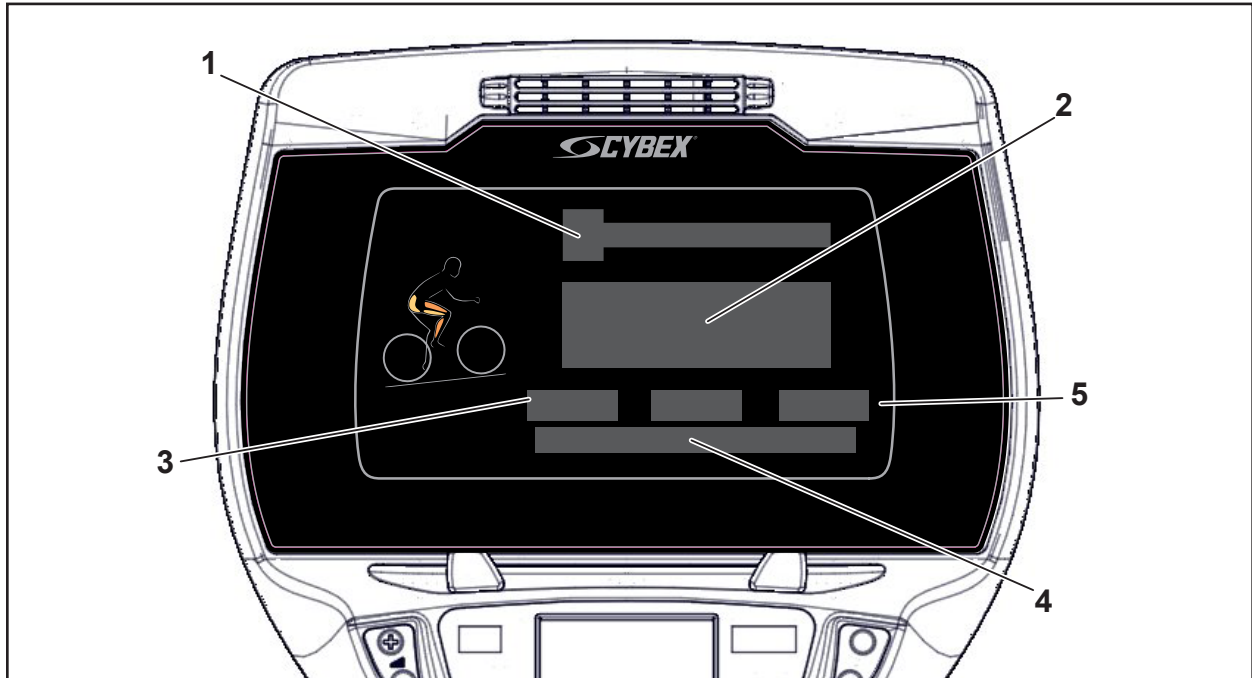

1	Target Bar	4	Enunciator
2	Bar Graph	5	Heart Rate Indicator
3	Data Readouts		

E3 View Monitor

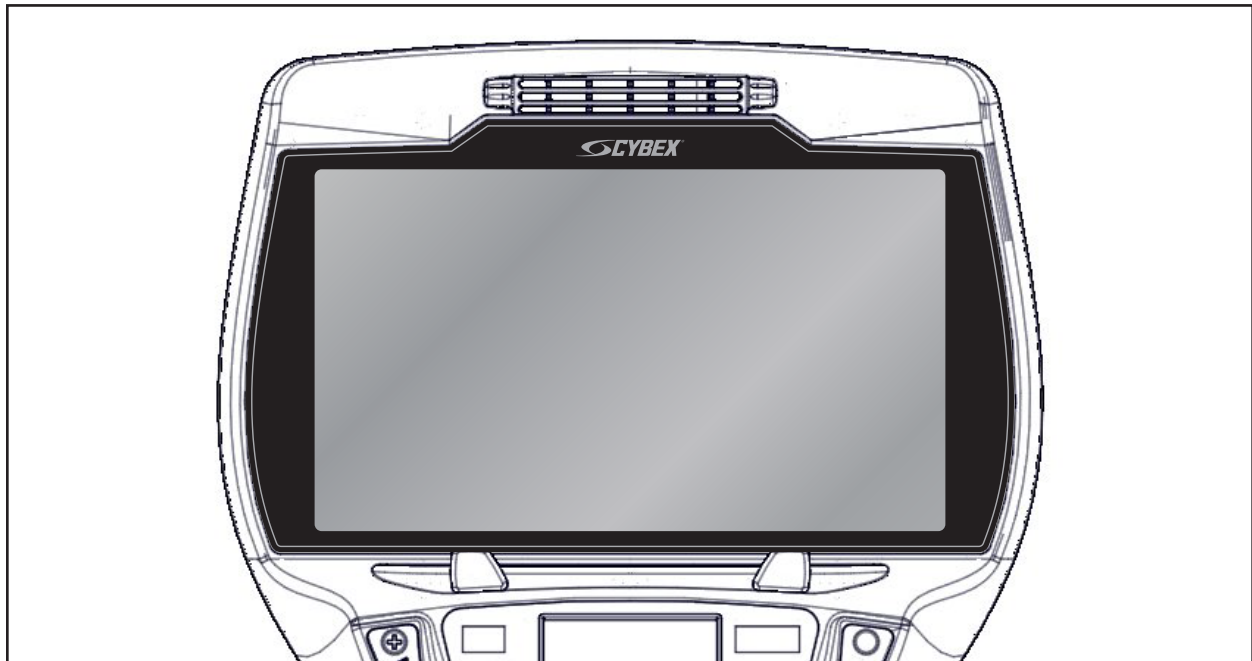

User Controls

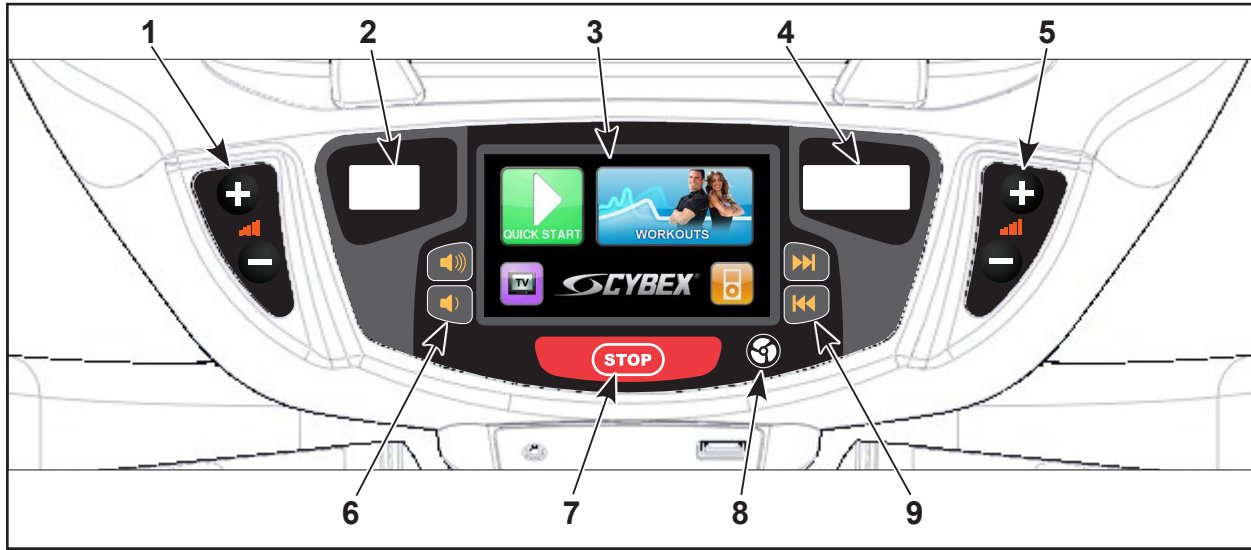

1	Gear/Power/RPM Keys (Left)	6	Volume Keys
2	Gear/Level Display	7	STOP Key
3	CardioTouch Screen	8	Fan Key
4	Speed/Power/RPM Display	9	Channel/Track Keys
5	Gear/Power/RPM Keys (Right)		

CardioTouch Screen — Tap the icons to make selections.



Mount and Dismount

To mount unit safely:

1. Verify pedals are completely stopped.
2. Grasp handrail and step carefully onto pedals.

To dismount unit safely:

1. Wait until pedals come to a complete stop.
2. Grasp handrails for support and carefully step off unit.

Emergency Dismount

If experiencing pain, feeling faint or needing to stop unit in an emergency situation:

1. Grasp handrails for support.
2. Stop pedalling.
3. Continue holding the handrails while carefully stepping off the unit.

Quick Operation Guide

Maximum user weight is 400 lbs. (181 kg).

The following is a quick overview of the operation of the unit. For more information read *Detailed Operation Guide* in this chapter.

1. Verify pedals are completely stopped.
2. Grasp handrails and step carefully into pedals. Begin pedaling.
3. Tap **QUICK START** on the CardioTouch screen.



4. Tap the **Weight** icon to select weight.
5. Tap the keypad to enter user weight.
6. Press the **ENTER**  icon to complete weight input.
7. Press the **Gear/Power/RPM + –** keys to change the Gear/Power/RPM at any time.
8. Press the **Stop** key at any time to end workout. "Workout Review" is displayed.

Detailed Operation Guide

Maximum user weight is 400 lbs. (181 kg).

Skip step 1 if unit is not equipped with a power cord.

1. Plug the E3 View monitor power cord or optional power cord into a power outlet from a grounded circuit, See **Electrical Requirements**. Coil up the remainder of the power cord and place it out of the way. The control panel will light up and be in the Dormant Mode.
2. Verify pedals are completely stopped.
3. Grasp handrails and step carefully into pedals. Begin pedaling.
4. Select **Quick Start** or **Workouts**.

If **Quick Start** is selected, The console will beep for one second and enter *Active Mode*.

If **Workouts** is selected, Select a workout and setup options.

Tap one of the workout type icons from the workout options screen.

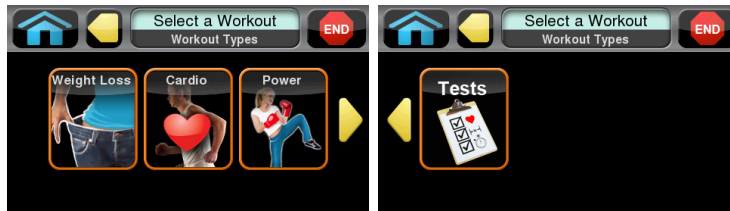

Tap one of the workout icons from the workouts screen.

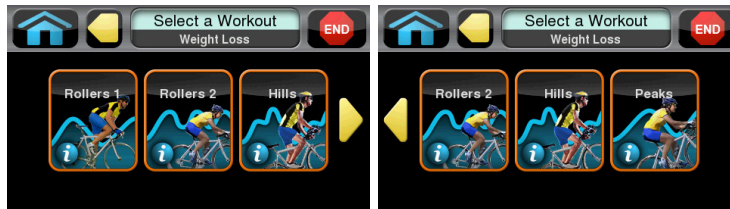

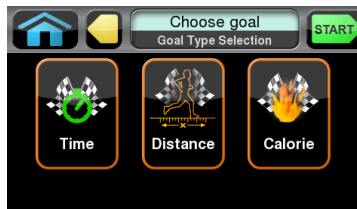

Select a goal of Time, Distance, or Calorie.

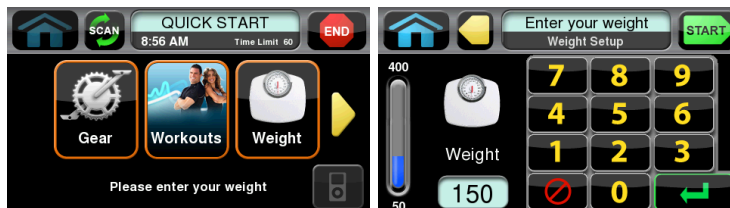

Tap the **Start** key to begin workout.

For the most accurate resistance and calorie count, you must set your correct weight before beginning your workout (including clothing). Valid weight range is 50 - 400 lbs, 23-181 kgs, or 3.6-28.6 stones.



Tap the **ENTER**  icon to accept the displayed value and either move forward in the setup process or review more options.

5. Tap the **Start** icon.
6. Observe the console.

LED Console

Target Bar	Target row: Displays target RPM for workouts that require a target speed. RPM row: Display actual crank RPM.
Bar Graph	Displays a graphical representation of the relative power (watt) changes, and if in a workout, will show the relative intensity changes that are coming up.
Data Readouts	Displays the workout values such as Distance, Calories, BPM (Heart rate, if available), MET and RPM (crank RPM in rotations per minute).
Enunciator	The <i>Enunciator</i> displays the titles of the Data Readouts.

E3 View Monitor



When screen option of TV and Data or Data Only is selected, display the workout values such as Distance, Calories, BPM (Heart rate, if available), MET and RPM (crank RPM in rotations per minute).

Heart rate will be displayed in lieu of MET if a valid heart rate is available from a wireless chest strap (not included) or by holding the contact heart rate grips.

7. Press the **Gear/Power/RPM + –** keys to change the Gear/Power/RPM at any time. The display will show the current gear or watt level. Gear range is 1-21, watt level range is 20-500.

When you adjust Gear/Power/RPM in a workout, the change will affect only the current segment. The workout control will resume starting with the next segment. To increase or decrease overall intensity, adjust the Gear, Power, or RPM.

8. Press the **STOP** key at any time to end workout.

- If pause feature is enabled, pause icon  is shown. Tap pause icon once to enter pause mode.
- If pause feature is disabled, stop icon  is shown. Tap stop icon or press **STOP** button once to end workout and enter "Workout review".

Workout Review is shown for approximately 20 seconds, showing each set of information twice before exiting to Dormant or powering off.

Workout Selection

Workout Choices:

Workout	Levels	Settings
Weight Loss		
Rollers 1	21	Select goal*, level and weight.
Rollers 2	21	Select goal*, level and weight.
Hills	21	Select goal*, level and weight.
Peaks	21	Select goal*, level and weight.
Cardio		
Ramps	21	Select goal*, level and weight.
Interval	21	Select goal*, level and weight.
Bursts	21	Select goal*, level and weight.
Wave	21	Select goal*, level and weight.
Heart Rate Control (HRC)**	NA	Select goal*, weight, age, and target heart rate.
Power		
Constant Power	21	Select goal*, weight and power.
Isokinetic	21	Select goal*, weight and target RPM.
Tests		
YMCA		Select age, weight and gender.

*A goal is Time, Distance, or Calorie.

**The Heart Rate Control workout requires wearing a Polar® compatible chest strap (not included).

Navigation

The CardioTouch display is active during the setup process to key in time, level, and weight values.

Tap the **ENTER**  icon to accept the displayed value and either move forward in the setup process or review more options.

The **START** icon may be pressed any time during this process to accept all workout defaults. If no activity is performed after a workout is selected, the unit will default to the settings of the current workout selected.

See Appendix for Workout Overviews

Data Readouts

As the user exercises, the unit keeps track of and displays the following data:

BPM (Beats per Minute) – User's current heart rate. Heart rate will appear when a signal is introduced. Use either the hand grips for Contact Heart Rate or a Polar® compatible heart rate transmitter.

Calories – The total accumulated calories burned during workout.

Calories Per Hour – Calculation of present workload's energy exertion in Calories per Hour.

Distance – The total accumulated distance during workout. Depending on the defaults chosen this measurement will show as Miles or Kilometers.

Level - Displays level of workout, range is 1-21.

MET (Metabolic Equivalent) – Displayed only if no BPM signal is present. A MET is the metabolic equivalent to the energy expended by the human body at rest. Anything over one MET is considered exertion. MET are calculated by the display and updated every 1 – 1.2 seconds.

$$\text{MET} = \text{Cal/Hr} \times 2.2 / \text{User Weight}$$

RPM (Rotation Per Minute) – User's crank revolutions per minute.

Time - Displays total time of workout or time remaining.

MM:SS	Minutes:Seconds	00:01 to 99:99
MMMM	Minutes	100 minutes or more

WATT – Present workload energy exertion.





Weight - Displayed when the console prompts for the user to enter their body weight.

Workout - Displayed when the console prompts the user to select a workout.

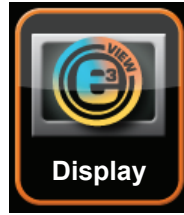
E3 View Monitor Screen (Optional)

During operation four E3 View Monitor screen options are available. Press E3 View Monitor icon to change screens.







	TV + Data	Display video with data at bottom of screen
	TV Only	Display video only
	Data Only	Display data only
	Blank	Screen is blank, video and data are not displayed

Heart Rate Indicator

Contact Heart Rate – Lightly hold hand grips on the handlebar ensuring that hands are clean and contact both the front and back sensors of each grip. During this time the heart rate LED will cycle through all of the colors. Do not move hand position on grips during this time. A heart rate will display in typically 30 seconds or less.

Once the actual heart rate is determined, the backlit heart will blink at that rate. The color of the heart represents a scale of low to high, providing for zones the user can target.

	Blue	0 – 69 BPM
	Green	70 – 93 BPM
	Yellow	94 – 119 BPM
	Blood Orange	120 – 169
	Magenta	170 and higher

Factors that interfere with heart rate signal:

- hand lotions
- oils or body powder
- excessive dirt
- excessive movement
- body composition
- hydration
- too loose grip
- too tight grip
- resting or leaning on grips

Wireless Heart Rate – To use this feature, a Polar® compatible heart rate transmitter belt (not included) must be worn.

Fan Control

The fan defaults to the “OFF” setting. The user can change to “Fan Low”, “Fan High”, or “Fan Off” setting by pressing the fan  key.

iPod Functions

Connecting an iPod — Connecting an iPod allows the unit to control the iPod through the CardioTouch screen and charges the iPod.

1. Connect iPod (not supplied) into the 30 pin connector.
2. Place iPod (not supplied) in the accessory tray.

iPod Playlist — Select the iPod icon to display the iPod navigation screen.

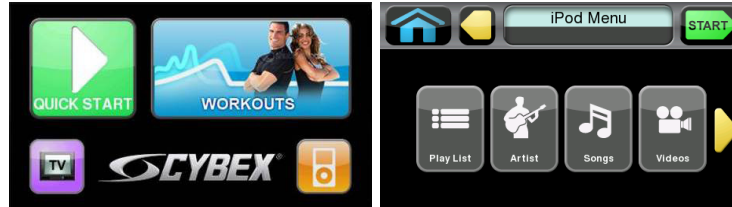

- If iPod is already playing, the CardioTouch screen will show common iPod controls for Listings, Repeat, Shuffle and Pause.
- Once a selection is made from the iPod menu, make further selections until music or videos are found.

Battery Sentry

Battery Sentry uses crank RPM or key presses to determine user presence. If a user is not detected within 10 seconds, the CardioTouch Screen displays “Are you there?”

Resume pedaling or touch the screen to reset the sentry, otherwise the bike will exit the workout.

Preventive Maintenance

All preventive maintenance activities must be performed on a regular basis. Performing routine preventive maintenance actions can aid in providing safe, trouble-free operation of all Cybex equipment.

Cybex is not responsible for performing regular inspection and maintenance actions for your machines. Instruct all personnel in equipment inspection and maintenance actions and also in accident reporting/recording. Cybex representatives are available to answer any questions that you may have.

Warnings



Read all warnings in this chapter.



WARNING: For maintenance, service and repair:

- *Must be performed by trained service personnel only*
- *Use only Cybex replacement parts*
- *Unplug unit before working on it*
- *Keep water and liquids away from electrical parts.*

Observe the following warnings:



DANGER: Electrocutation hazard.

To avoid death or serious injury unplug unit when not in use or when performing maintenance.



WARNING: Equipment hazard.

To avoid serious injury or death replace worn or damaged components immediately and keep the equipment out of use until repair is completed.

Cleaning Unit

1. Spray a clean cloth with a mild cleaning agent, such as a water and dish soap solution.
2. Wipe unit.

Do not spray cleaning solution directly on unit. Direct spraying could cause damage to electronics and may void warranty.

After Each Use:

- Wipe up any liquid spills immediately.
- Wipe up any remaining perspiration from handles and painted surfaces.
- Be careful not to spill or get excessive moisture on the console and display overlays, as this might create an electrical hazard or cause failure of the electronics.
- Clean heart rate grips using a cloth dampened with a cleaning solution containing alcohol.

The heart rate grips are the only part of the unit where a cleaning solution containing alcohol should be used.

Preventive Maintenance Activities

Perform regular preventive maintenance to ensure normal operation of unit. Keep a log of all maintenance actions to assist in staying current with all preventive maintenance activities.

Cybex is not responsible for performing regular inspection and maintenance actions for your unit. Instruct all personnel in equipment inspection and maintenance actions and also in accident reporting/recording. Contact Cybex Customer Service at 888-462-9239 or 508-533-4300 for any preventive maintenance or service concerns.



Read and understand warnings listed in this chapter and in the **Safety Section**. Read and understand all instructions in this section.

During maintenance, disconnect the external power source. If unit has the optional AC Power Kit unplug the power cord from the power outlet.

Rechargeable Battery

The unit is designed with a 12 volt Lead-Acid rechargeable battery. The battery will recharge during regular operation of unit or when the optional power adapter is plugged in.

The display will indicate dashes in the left display if the battery fails to provide enough energy.

If the battery is completely discharged, the workout review will also be truncated if the user is not striding during the time period. See Customer Service for contact information to replace the battery or purchase the optional AC adapter kit.

Battery replacement must be performed only by qualified technician.

Remove battery and dispose of safely before unit disposal.

Environment

Humidity and Static Electricity

The unit is designed to function normally in an environment with a relative humidity range of 30% to 75%. The unit can be shipped and stored in a relative humidity range of 10% to 90%.

Climatic dry air may cause static electricity. During workout, user may experience a shock due to build up of static electricity on the body and the discharge path of the unit. If static electricity is experienced, increase humidity to a comfortable level through the use of a humidifier.

Do not install, use or store the unit in an area of high humidity, such as in the vicinity of a steam room, sauna, indoor pool or outdoors. Exposure to extensive water vapor, chlorine and/or bromine could adversely affect the electronics as well as other parts of the unit.

Temperature

The unit is designed to function normally in an environment with an ambient temperature range of 50° F (10° C) to 104° F (40° C). The unit can be shipped and stored in an environment with an ambient temperature range of 32° F (0° C) to 140° F (60° C).

Customer Service

Product Registration

To register product do the following:

1. Visit www.cyboxintl.com.
2. Locate Product Registration in the Support section.
3. Fill out form completely.
4. Click the Submit button to register product.

Contacting Service

Hours of phone service are Monday through Friday from 8:30 a.m. to 6:00 p.m. Eastern Standard Time.

For Cybox customers living in the USA, contact Cybox Customer Service at 888-462-9239.

For Cybox customers living outside the USA, contact Cybox Customer Service at 508-533-4300 or fax 508-533-5183. Email address internationaltechhelp@cyboxintl.com

Find information on the web at www.cyboxintl.com.

To contact us online go to www.cyboxintl.com.

Ordering Parts

To order parts online go to www.cyboxintl.com.

To speak with a customer service representative, call 888-462-9239 (for customers living within the USA) or 508-533-4300 (for customers outside the USA).

The following information located on the serial number decal will assist our Cybox representatives in serving you.

- Unit Serial Number, Product Name and Model Number
- Part Description and Part Number if you have it. All parts can be found on the web at www.cyboxintl.com
- Shipping Address
- Contact Name
- Include a description of the problem.

In addition to your shipping address and contact name, your account number is helpful but not required. You may also fax orders to 508-533-5183.

Return Material Authorization (RMA)

The Return Material Authorization (RMA) system is used when returning material for placement, repair or credit. The system assures that returned materials are properly handled and analyzed. Follow the following procedures carefully.

Contact your authorized Cybex dealer on all warranty-related matters. Your local Cybex dealer will request a RMA from Cybex, if applicable. Under no circumstances will defective parts or equipment be accepted by Cybex without proper RMA and an Automated Return Service (ARS) label.

Please contact Cybex Customer Service for the return of any item that is defective.

Provide the technician with a detailed description of the problem you are having or the defect in the item you wish to return. Provide the model and serial number of your Cybex equipment.

At Cybex's discretion, the technician may request that you return the problem part(s) to Cybex for evaluation and repair or replacement. The technician will assign you a RMA number and will send you an ARS label. The ARS label and the RMA numbers must be clearly displayed on the outside of the package that contains the item(s) to be returned. Include the description of the problem, the serial number of the equipment and the name and address of the owner in the package along with the part(s).

Merchandise returned without an RMA number on the outside of the package or shipments sent COD will not be accepted by the Cybex receiving department.

Damaged Parts

Materials damaged in shipment should not be returned for credit. Shipping damages are the responsibility of the carrier (UPS, Federal Express, trucking companies, etc.)

Apparent Damage

Upon receipt of your shipment, check all items carefully. Any damage seen with a visual check must be noted on the freight bill and signed by the carrier's agent. Failure to do so will result in the carriers refusal to honor your damage claim. The carrier will provide you with the required forms for filing such claims.

Concealed Damage

Damage not seen with a visual check upon receipt of a shipment but notices later must be reported to the carrier as soon as possible. Upon discovery of the damage, a written or phone request to the carrier asking them to perform an inspection of the materials must be made within ten days of the delivery date. Keep all shipping containers and packing materials as they will be needed in the inspection process. The carrier will provide you with an inspection report and the necessary forms for filing a concealed damage claim. Concealed damage claim is the carrier's responsibility.

Appendix - Workout Overviews

Weight Loss - Rollers 1

This workout is designed for low to medium intensity training that the user can sustain for an extended period of time. It uses a low intensity resistance baseline for its two and a half minute core workout with forty-five second periods of higher resistance. The constant variety provides for periods of higher expenditure and training effect without the introduction of undue fatigue allowing the user to perform for longer periods of time.

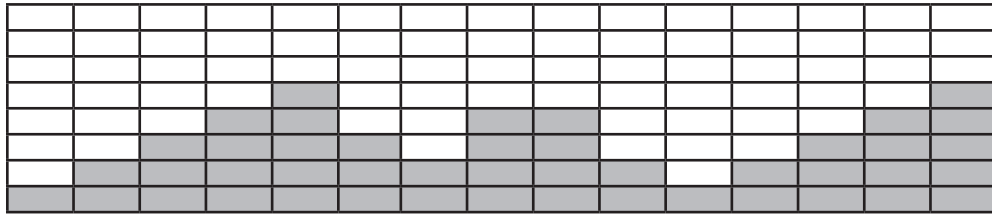

Watt per level/gear

Time	:30	:30	:30	:30	:45	:30	:30	:45	:45	:45	:30
	Warm Up				Core Segments				Cool Down		
Level	1	2	3	4	1	2	3	4	1	2	3
21	50	100	150	200	250	150	100	150	150	100	50
20	50	90	135	180	225	135	90	135	135	90	50
19	50	90	130	175	220	130	90	130	130	90	50
18	50	85	125	165	205	125	85	125	125	85	50
17	45	80	115	155	195	115	80	115	115	80	45
16	45	80	115	150	190	115	80	115	115	80	45
15	45	75	105	140	175	105	75	105	105	75	45
14	45	75	105	135	170	105	75	105	105	75	45
13	40	65	90	120	150	90	65	90	90	65	40
12	40	60	85	110	140	85	60	85	85	60	40
11	40	60	80	105	130	80	60	80	80	60	40
10	40	60	80	100	125	80	60	80	80	60	40
9	40	55	75	95	115	75	55	75	75	55	40
8	35	50	65	85	105	65	50	65	65	50	35
7	35	45	60	75	95	60	45	60	60	45	35
6	35	45	55	70	85	55	45	55	55	45	35
5	35	45	55	65	80	55	45	55	55	45	35
4	30	35	45	55	65	45	35	45	45	35	30
3	30	35	40	50	60	40	35	40	40	35	30
2	30	35	40	45	55	40	35	40	40	35	30
1	30	35	40	45	50	40	35	40	40	35	30

Weight Loss - Rollers 2

This workout is a two and a half-minute core workout designed to give the users the experience of riding constantly rolling hills without the steep grades of the Hills workout. Users will ride at a lower intensity with twice as much time spent at each resistance level and a two-minute rest period before the core workout repeats.

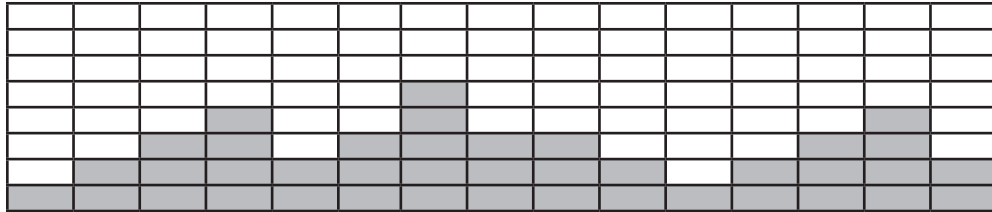

Watt per level/gear

Time	:30	:30	:30	:30	:15	1:00	:45	:30	:45	:45	:30
	Warm Up				Core Segments				Cool Down		
Level	1	2	3	4	1	2	3	4	1	2	3
21	50	100	150	200	100	150	250	150	150	100	50
20	50	90	135	180	90	135	225	135	135	90	50
19	50	90	130	175	90	130	220	130	130	90	50
18	50	85	125	165	85	125	205	125	125	85	50
17	45	80	115	155	80	115	195	115	115	80	45
16	45	80	115	150	80	115	190	115	115	80	45
15	45	75	105	140	75	105	175	105	105	75	45
14	45	75	105	135	75	105	170	105	105	75	45
13	40	65	90	120	65	90	150	90	90	65	40
12	40	60	85	110	60	85	140	85	85	60	40
11	40	60	80	105	60	80	130	80	80	60	40
10	40	60	80	100	60	80	125	80	80	60	40
9	40	55	75	95	55	75	115	75	75	55	40
8	35	50	65	85	50	65	105	65	65	50	35
7	35	45	60	75	45	60	95	60	60	45	35
6	35	45	55	70	45	55	85	55	55	45	35
5	35	45	55	65	45	55	80	55	55	45	35
4	30	35	45	55	35	45	65	45	45	35	30
3	30	35	40	50	35	40	60	40	40	35	30
2	30	35	40	45	35	40	55	40	40	35	30
1	30	35	40	45	35	40	50	40	40	35	30

Weight Loss - Hills

This workout is a three-minute core workout designed to give the user an intense interval workout. Users will experience intervals of moderate resistance at the beginning to simulate the start of the climb and will deliver peak resistance after two and a half minutes. The resistance then returns to the preliminary level and the core workout repeats itself.

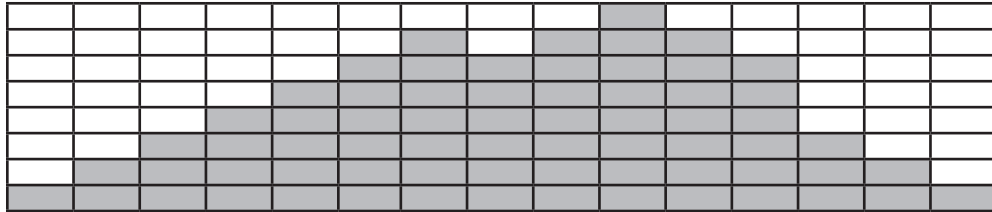

Watt per level/gear

Time	:30	:30	:30	:30	:30	:30	:30	:15	:15	:30	:15	:15	:45	:45	:30
	Warm Up				Core Segments								Cool Down		
Level	1	2	3	4	1	2	3	4	5	6	7	8	1	2	3
21	50	100	150	200	250	300	350	300	350	400	350	300	150	100	50
20	50	90	135	180	225	275	325	275	325	375	325	275	135	90	50
19	50	90	130	175	220	265	315	265	315	365	315	265	130	90	50
18	50	85	125	165	205	250	295	250	295	345	295	250	125	85	50
17	45	80	115	155	195	235	280	235	280	325	280	235	115	80	45
16	45	80	115	150	190	230	270	230	270	315	270	230	115	80	45
15	45	75	105	140	175	215	255	215	255	300	255	215	105	75	45
14	45	75	105	135	170	205	245	205	245	285	245	205	105	75	45
13	40	65	90	120	150	185	220	185	220	260	220	185	90	65	40
12	40	60	85	110	140	170	205	170	205	240	205	170	85	60	40
11	40	60	80	105	130	160	190	160	190	225	190	160	80	60	40
10	40	60	80	100	125	150	180	150	180	210	180	150	80	60	40
9	40	55	75	95	115	140	165	140	165	195	165	140	75	55	40
8	35	50	65	85	105	125	150	125	150	175	150	125	65	50	35
7	35	45	60	75	95	115	135	115	135	160	135	115	60	45	35
6	35	45	55	70	85	105	125	105	125	145	125	105	55	45	35
5	35	45	55	65	80	95	115	95	115	135	115	95	55	45	35
4	30	35	45	55	65	80	95	80	95	115	95	80	45	35	30
3	30	35	40	50	60	70	85	70	85	100	85	70	40	35	30
2	30	35	40	45	55	65	75	65	75	90	75	65	40	35	30
1	30	35	40	45	50	60	70	60	70	85	70	60	40	35	30

Weight Loss - Peaks

This workout is a three-minute fifteen-second core workout that begins at a low intensity level and incrementally climbs to peak resistance after one and a half-minutes and remains at that level for 45 seconds before ramping back down to the initial level. The repetitive workout is designed to keep the user in an aerobic state before reaching their anaerobic threshold.

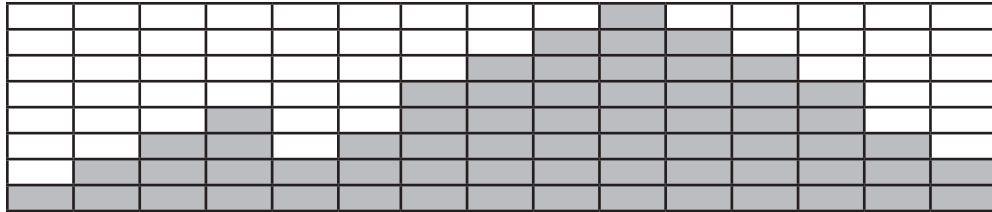

Watt per level/gear

Time	:30	:30	:30	:30	:15	:15	:15	:15	:15	:45	:15	:15	:15	:15	:15	:45	:45	:30
	Warm Up				Core Segments											Cool Down		
Level	1	2	3	4	1	2	3	4	5	6	7	8	9	10	11	1	2	3
21	50	100	150	200	100	150	250	300	350	400	350	300	250	150	100	150	100	50
20	50	90	135	180	90	135	225	275	325	375	325	275	225	135	90	135	90	50
19	50	90	130	175	90	130	220	265	315	365	315	265	220	130	90	130	90	50
18	50	85	125	165	85	125	205	250	295	345	295	250	205	125	85	125	85	50
17	45	80	115	155	80	115	195	235	280	325	280	235	195	115	80	115	80	45
16	45	80	115	150	80	115	190	230	270	315	270	230	190	115	80	115	80	45
15	45	75	105	140	75	105	175	215	255	300	255	215	175	105	75	105	75	45
14	45	75	105	135	75	105	170	205	245	285	245	205	170	105	75	105	75	45
13	40	65	90	120	65	90	150	185	220	260	220	185	150	90	65	90	65	40
12	40	60	85	110	60	85	140	170	205	240	205	170	140	85	60	85	60	40
11	40	60	80	105	60	80	130	160	190	225	190	160	130	80	60	80	60	40
10	40	60	80	100	60	80	125	150	180	210	180	150	125	80	60	80	60	40
9	40	55	75	95	55	75	115	140	165	195	165	140	115	75	55	75	55	40
8	35	50	65	85	50	65	105	125	150	175	150	125	105	65	50	65	50	35
7	35	45	60	75	45	60	95	115	135	160	135	115	95	60	45	60	45	35
6	35	45	55	70	45	55	85	105	125	145	125	105	85	55	45	55	45	35
5	35	45	55	65	45	55	80	95	115	135	115	95	80	55	45	55	45	35
4	30	35	45	55	35	45	65	80	95	115	95	80	65	45	35	45	35	30
3	30	35	40	50	35	40	60	70	85	100	85	70	60	40	35	40	35	30
2	30	35	40	45	35	40	55	65	75	90	75	65	55	40	35	40	35	30
1	30	35	40	45	35	40	50	60	70	85	70	60	50	40	35	40	35	30

Cardio - Ramps

This workout is a three-minute forty-five second core workout with a progressively increasing resistance profile designed to encourage the user to work towards their anaerobic energy system. The first three stages are forty-five seconds each and with the last three at thirty seconds each ending with the final stage at peak resistance. The resistance then returns to the preliminary level and the core workout repeats itself.

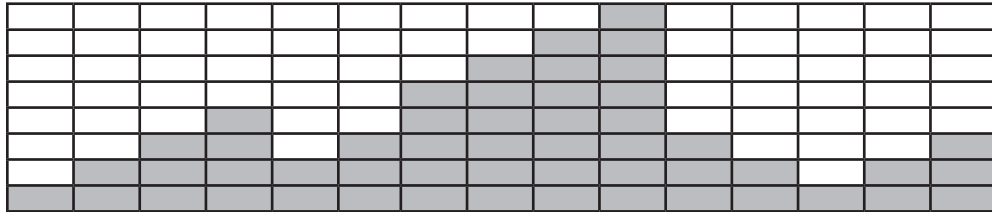

Watt per level/gear

Time	:30	:30	:30	:30	:45	:45	:45	:30	:30	:30	:45	:45	:30
	Warm Up				Core Segments						Cool Down		
Level	1	2	3	4	1	2	3	4	5	6	1	2	3
21	50	100	150	200	100	150	250	300	350	400	150	100	50
20	50	90	135	180	90	135	225	275	325	375	135	90	50
19	50	90	130	175	90	130	220	265	315	365	130	90	50
18	50	85	125	165	85	125	205	250	295	345	125	85	50
17	45	80	115	155	80	115	195	235	280	325	115	80	45
16	45	80	115	150	80	115	190	230	270	315	115	80	45
15	45	75	105	140	75	105	175	215	255	300	105	75	45
14	45	75	105	135	75	105	170	205	245	285	105	75	45
13	40	65	90	120	65	90	150	185	220	260	90	65	40
12	40	60	85	110	60	85	140	170	205	240	85	60	40
11	40	60	80	105	60	80	130	160	190	225	80	60	40
10	40	60	80	100	60	80	125	150	180	210	80	60	40
9	40	55	75	95	55	75	115	140	165	195	75	55	40
8	35	50	65	85	50	65	105	125	150	175	65	50	35
7	35	45	60	75	45	60	95	115	135	160	60	45	35
6	35	45	55	70	45	55	85	105	125	145	55	45	35
5	35	45	55	65	45	55	80	95	115	135	55	45	35
4	30	35	45	55	35	45	65	80	95	115	45	35	30
3	30	35	40	50	35	40	60	70	85	100	40	35	30
2	30	35	40	45	35	40	55	65	75	90	40	35	30
1	30	35	40	45	35	40	50	60	70	85	40	35	30

Cardio - Interval

This workout uses a 1:2 work to rest ratio. It is designed for high resistance training with longer rest periods. Users will face a high level of resistance for thirty-seconds followed by a one minute recuperation period before performing the interval again.

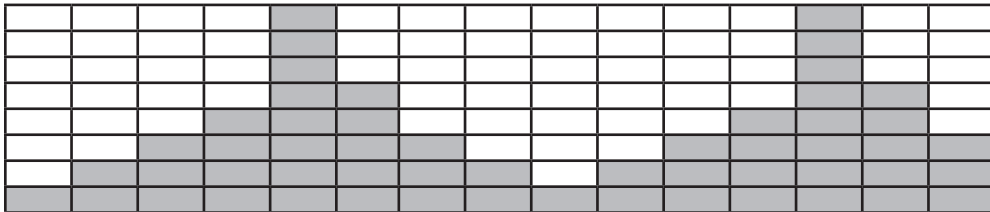

Watt per level/gear

Time	:30	:30	:30	:30	:30	1:00	:45	:45	:30
	Warm Up				Core Segments		Cool Down		
	1	2	3	4	1	2	1	2	3
21	50	100	150	200	400	250	150	100	50
20	50	90	135	180	375	225	135	90	50
19	50	90	130	175	365	220	130	90	50
18	50	85	125	165	345	205	125	85	50
17	45	80	115	155	325	195	115	80	45
16	45	80	115	150	315	190	115	80	45
15	45	75	105	140	300	175	105	75	45
14	45	75	105	135	285	170	105	75	45
13	40	65	90	120	260	150	90	65	40
12	40	60	85	110	240	140	85	60	40
11	40	60	80	105	225	130	80	60	40
10	40	60	80	100	210	125	80	60	40
9	40	55	75	95	195	115	75	55	40
8	35	50	65	85	175	105	65	50	35
7	35	45	60	75	160	95	60	45	35
6	35	45	55	70	145	85	55	45	35
5	35	45	55	65	135	80	55	45	35
4	30	35	45	55	115	65	45	35	30
3	30	35	40	50	100	60	40	35	30
2	30	35	40	45	90	55	40	35	30
1	30	35	40	45	85	50	40	35	30

Cardio - Bursts

This workout is designed with the specific goal of raising the users' lactic acid threshold. The workout uses a 1:3 work to rest ratio with fifteen-second intervals for maximum power development and forty-five second rest periods for recuperation.

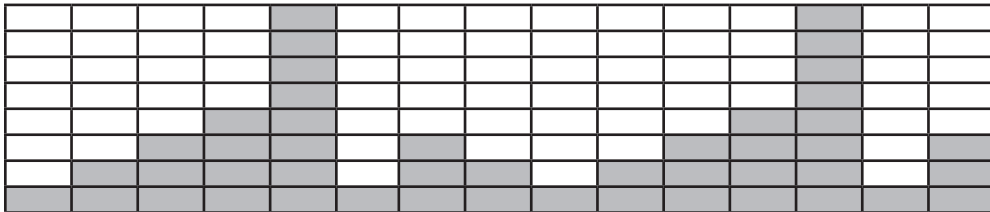

Watt per level/gear

Time	:30	:30	:30	:30	:15	:45	:45	:45	:30
	Warm Up				Core Segments		Cool Down		
	1	2	3	4	1	2	1	2	3
21	50	100	150	200	400	50	150	100	50
20	50	90	135	180	375	50	135	90	50
19	50	90	130	175	365	50	130	90	50
18	50	85	125	165	345	50	125	85	50
17	45	80	115	155	325	45	115	80	45
16	45	80	115	150	315	45	115	80	45
15	45	75	105	140	300	45	105	75	45
14	45	75	105	135	285	45	105	75	45
13	40	65	90	120	260	40	90	65	40
12	40	60	85	110	240	40	85	60	40
11	40	60	80	105	225	40	80	60	40
10	40	60	80	100	210	40	80	60	40
9	40	55	75	95	195	40	75	55	40
8	35	50	65	85	175	35	65	50	35
7	35	45	60	75	160	35	60	45	35
6	35	45	55	70	145	35	55	45	35
5	35	45	55	65	135	35	55	45	35
4	30	35	45	55	115	30	45	35	30
3	30	35	40	50	100	30	40	35	30
2	30	35	40	45	90	30	40	35	30
1	30	35	40	45	85	30	40	35	30

Cardio - Wave

This workout is designed to maintain a high total demand with one minute at peak resistance out of the total two and a half minute core workout. The prolonged exertion period takes advantage of the long term energy stores and total aerobic capability when associated with speeds that require a high sustained cardiovascular demand. Users will benefit from a forty-five second recuperation period before beginning the next interval.

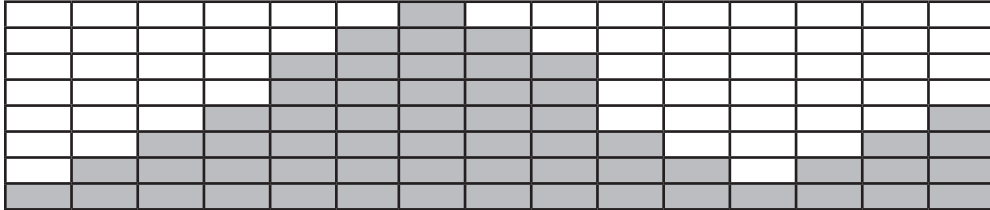

Watt per level/gear

Time	:30	:30	:30	:30	:45	:30	:30	:45	:45	:45	:30	
	Warm Up				Core Segments					Cool Down		
Level	1	2	3	4	1	2	3	4	5	1	2	3
21	50	100	150	200	300	350	400	350	300	150	100	50
20	50	90	135	180	275	325	375	325	275	135	90	50
19	50	90	130	175	265	315	365	315	265	130	90	50
18	50	85	125	165	250	295	345	295	250	125	85	50
17	45	80	115	155	235	280	325	280	235	115	80	45
16	45	80	115	150	230	270	315	270	230	115	80	45
15	45	75	105	140	215	255	300	255	215	105	75	45
14	45	75	105	135	205	245	285	245	205	105	75	45
13	40	65	90	120	185	220	260	220	185	90	65	40
12	40	60	85	110	170	205	240	205	170	85	60	40
11	40	60	80	105	160	190	225	190	160	80	60	40
10	40	60	80	100	150	180	210	180	150	80	60	40
9	40	55	75	95	140	165	195	165	140	75	55	40
8	35	50	65	85	125	150	175	150	125	65	50	35
7	35	45	60	75	115	135	160	135	115	60	45	35
6	35	45	55	70	105	125	145	125	105	55	45	35
5	35	45	55	65	95	115	135	115	95	55	45	35
4	30	35	45	55	80	95	115	95	80	45	35	30
3	30	35	40	50	70	85	100	85	70	40	35	30
2	30	35	40	45	65	75	90	75	65	40	35	30
1	30	35	40	45	60	70	85	70	60	40	35	30

Cardio - Heartrate Control

This workout requires a Polar® compatible heart rate transmitter belt (not included).

The Heartrate Control (HRC) workout will attempt to bring the user to their target heartrate in 3-5 minutes, then keep them there for the duration of the body of the workout. A *Cool Down* is built in to the end of the workout. HRC is run in Constant Power and thus defines watts.

The user selects a target heartrate, which defaults to 75% of max. Limits should be set to not allow a Target HR (THR) less than 60% of max or more than 94% of max.

Max HR formula: $208 - (0.7 \times \text{Age})$.

The protocol starts in Stage II, with the entry point based on Target HR.

- 80 – 120 BPM = Step 6
- 121-127 BPM = Step 8
- 128-134 BPM = Step 10
- 135-up BPM = Step 12

A running pulse-to-pulse BPM value is continuously measured.

Every 15 seconds the user's pulse rate is sampled and a prediction function is evaluated (decision.) This is subtracted from the target heartrate to form an error value which is scaled and added to the current load value. There is a maximum rate of change of 15 steps per decision.

The workload equates to the speed of the workout. A chart of Step and Watts has been created. It has four defined stages:

- Stage 1 ramps the load from Step 1 to Step 5.
- Stage 2 ramps the load from Step 6 through Step 18.
- Stage 3 ramps the load from Step 19 through Step 39.
- Stage 4 ramps the load from Step 40 through Step 100.

The user has limited control over the load in that the user's selections are not permanent. At the next decision, a new load can be chosen by the software as described above to override any user modifications.

If the user presses the **LEVEL** key, they can modify their Target Heartrate real-time. Utilize the Target Heartrate Setup selection screen and exit back to the workout in progress, making the change to their target heartrate real-time.

Lost Signal

If a signal is lost for two consecutive decisions (roughly 30 seconds), the display will beep four times, show 'HR SIGNAL LOST', show dashes in the BPM window and show the heart solid white. During this HR signal lost period, the load will remain steady. If after two further decisions (roughly an additional 30 seconds) the heartrate signal has not been reestablished, continue to show 'HR SIGNAL LOST' on the Text area. The workout will reduce the workload by 10 steps per minute until minimum workload or Step 1. After one minute at minimum workload, go to *Exiting Active Mode*.

Cool Down

By default, *Cool Down* occurs at session time minus two minutes or if the user presses the **Cool Down** button. *Cool Down* goes to 75% of existing step, then drops by 1 step every 15 seconds for the remainder of *Cool Down*.

Stage 1		Stage 2		Stage 3		Stage 4	
Step	Watts	Step	Watts	Step	Watts	Step	Watts
1	25	6	50	19	115	40	220
2	30	7	55	20	120	41	225
3	35	8	60	21	125	42	230
4	40	9	65	22	130	43	235
5	45	10	70	23	135	44	240
		11	75	24	140	45	245
		12	80	25	145	46	250
		13	85	26	150	47	255
		14	90	27	155	48	260
		15	95	28	160	49	265
		16	100	29	165	50	270
		17	105	30	170	51	275
		18	110	31	175	52	280
				32	180	53	285
				33	185	54	290
				34	190	55	295
				35	195	56	300
				36	200	57	305
				37	205	58	310
				38	210	59	315
				39	215	60	320
						61	325
						62	330
						63	335
						64	340
						65	345
						66	350
						67	355

Cybex Owner's Manual

Stage 1		Stage 2		Stage 3		Stage 4	
Step	Watts	Step	Watts	Step	Watts	Step	Watts
						68	360
						69	365
						70	370
						71	375
						72	380
						73	385
						74	390
						75	395
						76	400
						77	405
						78	410
						79	415
						80	420
						81	425
						82	430
						83	435
						84	440
						85	445
						86	450
						87	455
						88	460
						89	465
						90	470
						91	475
						92	480
						93	485
						94	490
						95	495
						96	500
						97	505
						98	510
						99	515
						100	520

Power - Constant Power

Control the brake power from 35 to 500 Watts. The bike will decrease the resistance at higher speeds or increase resistance at slower speeds. The bike will maintain a constant power setting.

Power - Isokinetic

Accommodating resistance, where unit provides a corresponding amount of resistance on the user to keep them at a fixed pedal speed. Such exercise is used to test and improve muscular strength and endurance, especially after injury.

Tests - YMCA

This workout requires a Polar® compatible heart rate transmitter belt (not included). Test includes a warm up and three stages. The test result is a score, see charts below for ranking.

Male

Age	20-29	30-39	40-49	50-59	60-69
Elite	55+	52+	50+	48+	45+
Excellent	50-54	47-51	45-49	43-47	40-44
Good	45-49	42-46	40-44	38-42	35-39
Above Average	40-44	37-41	35-39	33-37	30-34
Average	36-39	33-36	31-34	29-32	26-29
Below Average	31-35	28-32	26-30	24-28	21-25
Poor	26-30	23-27	20-25	18-23	16-20
Very Poor	<26	<23	<20	<18	<16

Female

Age	20-29	30-39	40-49	50-59	60-69
Elite	49+	46+	44+	42+	40+
Excellent	44-48	41-45	39-43	37-41	35-39
Good	39-43	36-40	34-38	32-36	30-34
Above Average	34-38	31-35	29-33	27-31	25-29
Average	30-33	27-30	25-28	23-26	21-24
Below Average	25-29	22-26	20-24	18-22	16-20
Poor	20-24	17-21	15-19	13-17	11-15
Very Poor	<20	<17	<15	<13	<11