



Cybex 530S
Stepper Owner's Manual
Cardiovascular Systems
Part Number LT-18938-4 Rev D

www.cybexinternational.com



Cybex 530S
Stepper Owner's Manual
Cardiovascular Systems
Part Number LT-18938-4 Rev D

Cybex and the Cybex logo are registered trademarks of Cybex International, Inc. Polar® is a registered trademark of Polar.

DISCLAIMER: Cybex International, Inc. makes no representations or warranties regarding the contents of this manual. We reserve the right to revise this document at any time or to make changes to the product described within it without notice or obligation to notify any person of such revisions or changes.

© 2007, Cybex International, Inc. All rights reserved. Printed in United States of America.

10 Trotter Drive Medway, MA 02053 • 800-766-3211 • 508-533-4300 • FAX 508-533-5183
www.cybexinternational.com • techhelp@cybexintl.com • techpubs@cybexintl.com • LT-18938-4D • November 2007

About this Manual

An Owner's Manual is shipped with each unit. To purchase additional copies of this manual or any other Cybex manual, please do one of the following:

- order online at www.cybexinternational.com
- fax your order to 508-533-5183
- contact Cybex Customer Service at 888-462-9239
- or contact Cybex Customer Service at 508-533-4300

To contact Cybex with comments about this manual you may send email to techpubs@cybexintl.com.

FCC Compliance Information

! WARNING: Changes or modifications to this unit not expressly approved by the party responsible for compliance could void the user's authority to operate the equipment.

This equipment has been tested and found to comply with the limits for a Class B digital device, pursuant to Part 15 of the FCC Rules. These limits are designed to provide reasonable protection against harmful interference in a residential installation. This equipment generates, uses and can radiate radio frequency energy and, if not installed and used in accordance with the instructions, may cause harmful interference to radio communications. However, there is no guarantee that interference will not occur in a particular installation. If this equipment does cause harmful interference to radio or television reception (which can be determined by turning the equipment off and on) the user is encouraged to try to correct the interference by one or more of the following measures:

- Reorient or relocate the receiving antenna.
- Increase the separation between the equipment and receiver.
- Connect the equipment into an outlet on a circuit different from that to which the receiver is connected.
- Consult the dealer or an experienced radio TV technician for help.



DECLARATION OF CONFORMITY

August 24, 2006

This Declaration of Conformity is suitable to the European Standard EN 45014, "General criteria for supplier's declaration of conformity."

We,

Manufacturer: Cybox International, Inc.
10 Trotter Drive
Medway, MA 02053
USA
(508) 533-4300

EU Representative: Cybox International UK
Oaktree House
Atherstone Road
Measham
Swadlincote, Derbyshire DE12 7EL
United Kingdom
+44 (0)845 60 60 228

declare under our sole responsibility that the product(s):

Cybox 530S Stepper

to which this declaration relates is in conformity with the EEC directives listed herein below (including any and all relevant modifications):

73/23/EEC Low Voltage Directive

89/336/EEC Electromagnetic Compatibility



2002/95/EC Restriction of Hazardous Substances (RoHS) Directive

Art Hicks
Chief Operating Officer
Cybox International, Inc.
10 Trotter Drive
Medway, MA 02053





As a result of test reports and their evaluation by accredited laboratories, we are in possession of the following certificates for products which carry this marking:

Canada, USA		CAN/CSA-C22.2 No.68-92, UL Std. No. 1647, EN55022 Class B, FCC Part 15 Class B, EN 60335-1
European Union		73/23/EEC, 89/336/EEC

References of harmonized standards on which this declaration of conformity is based:

EN 61000-6-1:2001 Electromagnetic compatibility (EMC). Generic standard. Immunity for residential, commercial and light-industrial environments

EN 61000-6-3:2001 Electromagnetic compatibility (EMC). Generic standard. Emission standard for residential, commercial and light-industrial environments

EN 55022: 1998 (CISPR 22:1997), Class B Limits and Methods of Measurement of Radio Interference Characteristics of Information Technology Equipment.

EN 60335-1: 76 +A 1:77 + A 1:77 + A2:79 + A3:82 + A4:84 + A5:86 + A6:88 “Safety of Household and Similar Electrical Appliances: General Requirements”

EN 61000-4-2 Electromagnetic compatibility (EMC) - Part 4-2: Testing and measurement techniques - Electrostatic discharge immunity test

EN 61000-4-3 Electromagnetic compatibility (EMC) - Part 4-3: Testing and measurement techniques - Radiated, radio frequency, and electromagnetic field immunity test

EN 61000-4-4 Electromagnetic compatibility (EMC) - Part 4: Testing and measurement techniques - Section 4: Electrical fast transient/burst immunity test.





EN 61000-4-5 Electromagnetic compatibility (EMC)- Part 4-5: Testing and measurement techniques - Surge immunity test

EN 61000-4-6 Electromagnetic compatibility (EMC) - Part 4-6: Testing and measurement techniques - Immunity to conducted disturbances, induced by radio-frequency fields

EN 61000-4-8 Electromagnetic compatibility (EMC) - Part 4-8: Testing and measurement techniques - Power frequency magnetic field immunity test

EN 61000-4-11 Electromagnetic compatibility (EMC) - Part 4-11: Testing and measurement techniques - Voltage dips, short interruptions and voltage variations immunity tests

EN 61000-3-2 Electromagnetic compatibility (EMC) - Part 3-2: Limits - Limits for harmonic current emissions (equipment input current $\leq 16\text{A}$ per phase)

EN 61000-3-3 Electromagnetic compatibility (EMC) - Part 3-3: Limits - Limitation of voltage changes, voltage fluctuations and flicker in public low-voltage supply systems, for equipment with rated current $\leq 16\text{ A}$ per phase and not subject to conditional connection

EN 957-1: Stationary Training Equipment. General Safety Requirements and Test Methods

FCC Part 15, Subpart B - Class B Radiated and Conducted Emissions

CAN/CSA-C22.2 No. 68-92 (Reaffirmed 1999) Safety of Household and similar electrical appliances, General Instruction

ANSI / UL-1647 3rd Edition, March 28, 1997 Rev. May 9, 2006 Motor Operated Massage and Exercise Machines.



Table of Contents

Front Pages

About this Manual	i
FCC Compliance Information	i
Declaration Of Conformity	ii
Table of Contents	v

1 Safety

Important Voltage Information	1-1
Important Safety Instructions	1-1
Warning Decals	1-3
Warning Decals A/V Option	1-3
Warning Decals - 530S Stepper	1-4
CSAFE Port	1-5
Explanation of Symbols Used	1-6

2 Technical Specifications

Specifications	2-1
----------------------	-----

3 Operation

Terms and Symbols Used	3-1
Intended Use	3-2
Quick Operation Guide	3-3
Detailed Operation Guide	3-3
Stopping the 530S Stepper	3-5
Control During Operation	3-5
Data Readouts	3-6
Displaying Heart Rate	3-6
Use of Programs	3-7
Manual Mode	3-8
The Workout Profile	3-8
Meaning of METS	3-8
Heart Rate Control	3-9
Fitness Test	3-9
Hill Programs - Rolling Hills	3-11
Hill Programs - Hills	3-12
Hill Programs - The Divide	3-13
Interval Programs - Interval	3-14
Interval Programs - Sprint	3-15
Interval Programs - Ramps	3-16
Fitness Programs - Weight Loss	3-17
Fitness Programs - Cardio	3-18
Fitness Programs - Endurance	3-19

4 Preventive Maintenance

Warnings	4-1
Regular Maintenance Activities	4-1
Cleaning Your Cybox 530S	4-2
Drive Cable Maintenance	4-3
Environment	4-4
Storage	4-4

5 Setup and Assembly

Warnings	5-1
Choosing and Preparing a Site	5-1
Electrical Power Requirements	5-2
Assembling the Cybox 530S Stepper	5-2
Testing the Operation	5-10
Setting Operation Options	5-11

6 Customer Service

Contacting Service	6-1
Serial Number	6-1
Return Material Authorization (RMA)	6-2
Damaged Parts	6-3
Ordering Parts	6-3
Parts List	6-4

This page intentionally left blank.

1 - Safety

IMPORTANT: Read all instructions and warnings before using the unit.

Important Voltage Information

Before plugging the power cord into an electrical outlet, verify that the voltage requirements for your area match the voltage of the stepper that you have received.

The power requirements for the unit are a grounded circuit rated for one of the following: 115 VAC \pm 5%, 50/60 Hz; or 230 VAC \pm 10%, 50/60 Hz. Contact your electrician to ensure the power supply complies with local building codes. **NOTE:** Do not use a ground plug adapter to adapt the 3-prong power cord plug to a non-grounded electrical outlet.

Up to ten units can be daisy-chained together for single outlet use. Use daisy chain power supply cord supplied with unit (Part# AW-14004). The daisy-chain outlet is rated for 750 Watts.

Important Safety Instructions

(Save These Instructions)

! DANGER: To reduce the risk of electric shock, always unplug this unit from the electrical outlet immediately after using it and before cleaning it.

! WARNING: Serious injury could occur if these precautions are not observed. To reduce the risk of burns, fires, electric shock or injury:

NOTE: The data and statistics displayed on the unit (including heart rate) are not to be used to make a medical diagnosis from. Consult your physician.

User Safety Precautions

- Obtain a medical exam before beginning any exercise program.
- Stop exercising if you feel faint, dizzy, or experience pain and consult your physician.
- Obtain instruction before using. Lisez les instructions avant l'utilisation.
- Read and understand the Owner's Manual and all warnings posted on the unit before using.
- Keep clear of moving parts. DO NOT wear loose or dangling clothing while using.
- Use caution when mounting and dismounting.
- Keep children away. Teenagers and disabled must be supervised.
Tenez les enfants éloignés. Les adolescents et les handicapés doivent être surveillés.
- DO NOT use the unit if you exceed 400 lbs. (180 kg). This is the rated maximum user weight.

Cybex 530S Owner's Manual

- Report any malfunctions, damage or repairs to the facility.
- Replace any warning labels if damaged, worn or illegible.

Facility Safety Precautions

- Make sure all user and safety precautions are observed.
- Read the Owner's Manual carefully before assembling, servicing or using the equipment.
- Make sure that all users are properly trained on how to use the equipment.
- Make sure that each machine is set up and operated on a solid level surface. Do not install equipment on an uneven surface.
- Make sure there is enough room for safe access and operation of the equipment.
- Perform regular maintenance checks on the equipment. Also pay close attention to all areas most susceptible to wear, including (but not limited to) cables, pulleys, belts and grips.
- Immediately replace worn or damaged components. If unable to immediately replace worn or damaged components then remove from service until the repair is made.
- Do not attempt repairs, electrical or mechanical. Seek qualified repair personnel when servicing. If you live in the USA, contact Cybex Customer Service at 888-462-9239. If you live outside the USA, contact Cybex Customer Service at 508-533-4300.
- Disconnect all power before servicing the unit.
- Keep a repair log of all maintenance activities.
- Use only Cybex supplied components to maintain/repair the equipment.
- Do not use attachments for the stepper unless recommended by Cybex.
- Do not operate the stepper if: (1) the cord is damaged; (2) the stepper is not working properly or (3) if the stepper has been dropped or damaged. Seek service from a qualified technician.
- Do not use the stepper in damp or wet locations.
- Do not operate the stepper around or where aerosol (spray) or where oxygen products are being used.
- Do not use the stepper outdoors.

NOTE: *It is the sole responsibility of the user/owner or facility operator to ensure that regular maintenance is performed.*

Steppers containing the A/V options

- Devices connected to Cybex equipment must comply with appropriate safety standards. This includes but not limited to: UL-60950 and EN 60950.

Warning Decals

Carefully read and understand all warning decals before using the unit.

NOTE: To replace any worn or damaged decals do one of the following:
Visit www.cybexinternational.com to shop for parts online, fax your order to 508-533-5183 or contact Cybex Customer Service at 888-462-9239. If you live outside of the USA, call 508-533-4300.

Warning Decals - A/V Option

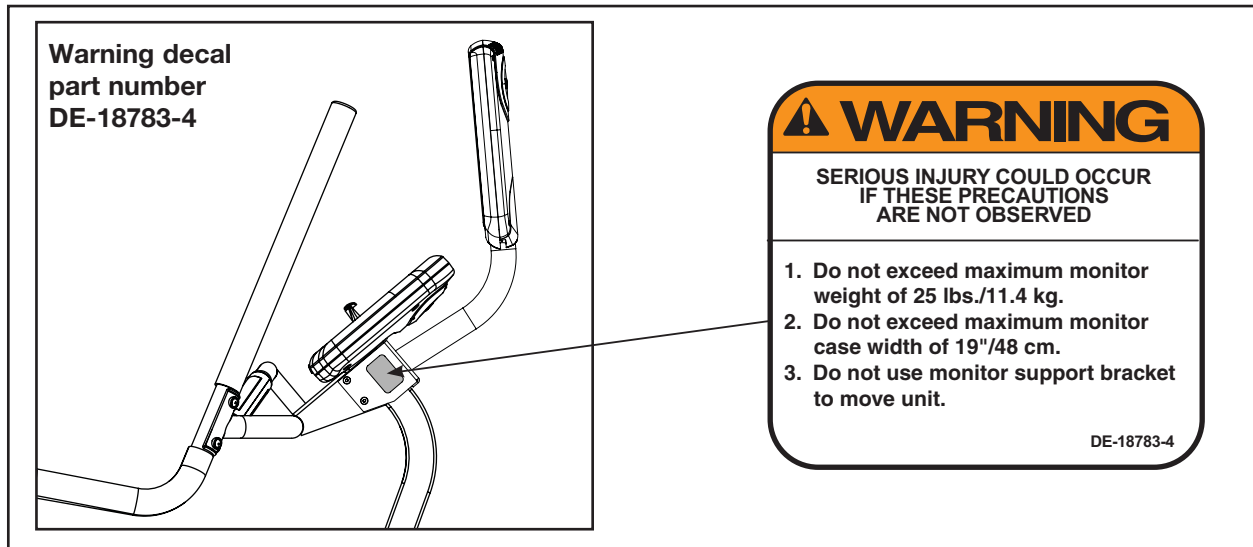

Warning Decals - 530S Stepper

Warning decals indicate a potentially hazardous situation, which, if not avoided, could result in death or serious injury. The warning decals used on the Cybox 530S Stepper are shown below.

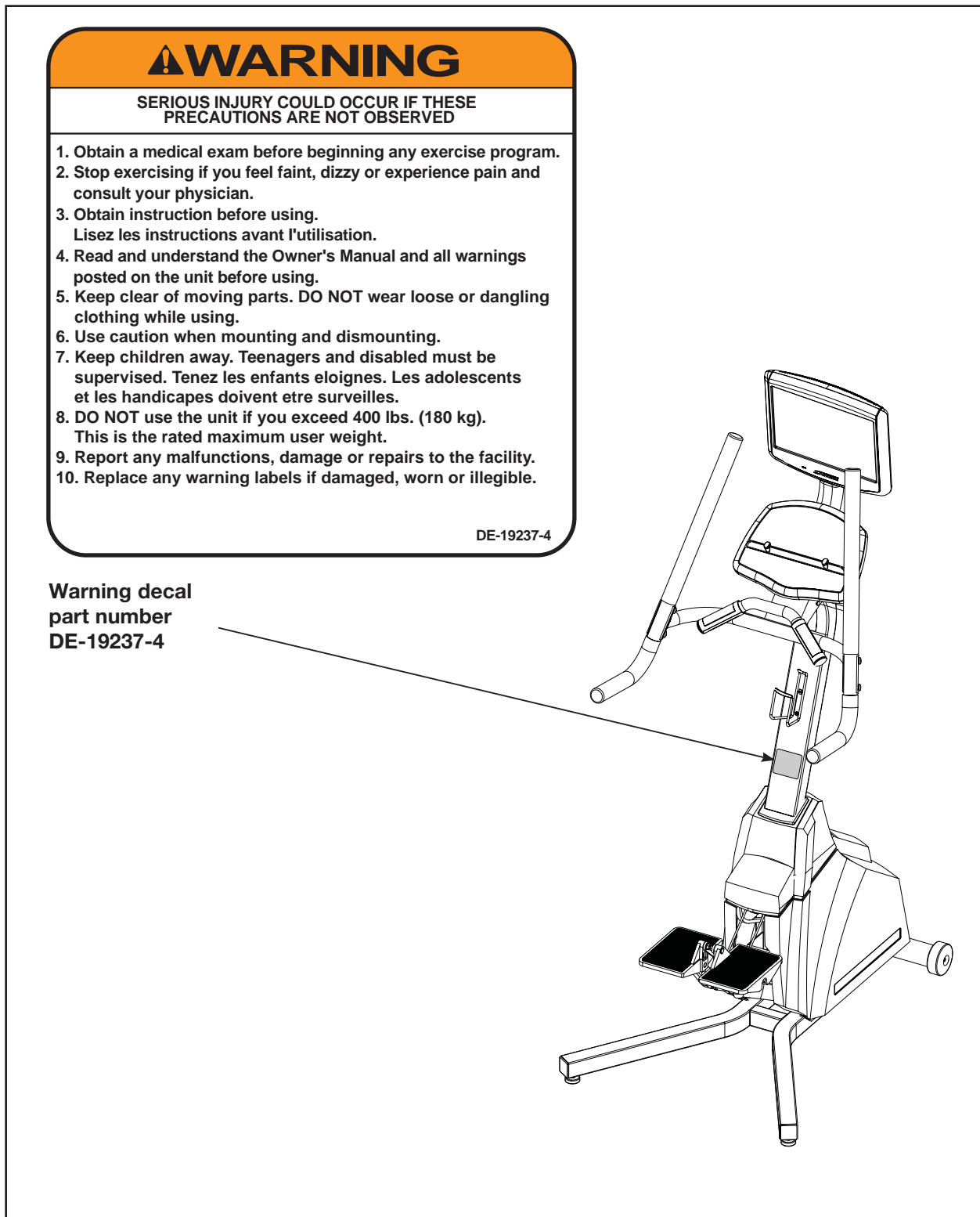

CSAFE Port

NOTE: The CSAFE standard defines a communication protocol and low-voltage DC power source specific to the Fitness Equipment Industry. These RJ-45 phone jacks are provided for use **ONLY** within the CSAFE protocol. For more information on the CSAFE standard, visit www.fitlinxx.com/csafa.

NOTE: The CSAFE port inside the console, accessible through the rear access door, is the only port in the Cyber stepper that carries **BOTH** the CSAFE communication lines **AND** the 8.0v DC CSAFE power supply. If you are attaching a CSAFE compliant device that requires power, you **MUST** use this connection. Power is present only when the stepper is plugged in and the power switch is in the on (I) position.

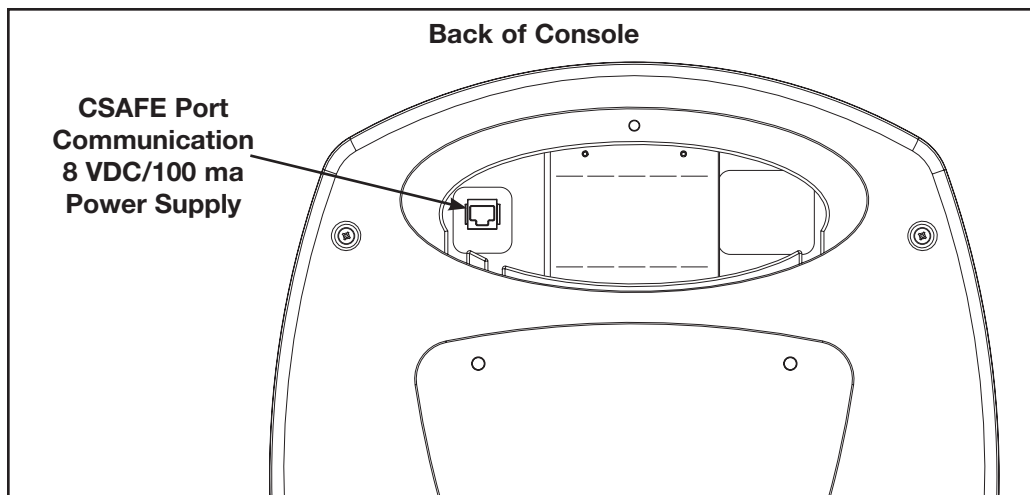

Explanation of Symbols Used



CE - The CE (Conformité Européenne) mark is a European Union approval indicating that a product complies with a European Directive.



Pause/End - Press to pause program.



Quick Start - Press to skip *Program Setup Mode* and enter *Manual Mode*.



Up Arrow - This key adjusts **Program, Weight, Time, Level, Age** or **BPM** up.



Down Arrow - This key adjusts **Program, Weight, Time, Level, Age** or **BPM** down.



Level Plus - This key adjusts **Level** up.



Level Minus - This key adjusts **Level** down.

2 - Technical Specifications

Specifications

Length:	45" (114 cm).
Width:	31" (79 cm).
Height:	73" (185 cm). With optional A/V monitor 78" (198cm).
Weight of Product:	151 lbs. (60 kg).
Shipping Weight:	173 lbs. (78 kg).
Resistance Type:	Friction Belt and Flywheel.
Programs:	Quick Start, Manual, Nine Programs and Heart Rate Control as well as a Fitness Test.
Console Features:	Upper console: Dot matrix of the profile. Distance, floors, calories, calories per hour, mets, speed and heart rate. Lower Console: LED display of time, speed and level.
Heart Rate Features:	Built-in wireless heart rate receiver (transmitter not included) and contact heart rate monitoring.
Frame Colors:	Standard: Black enclosure with choice of five standard colors. Custom: Unlimited colors available for console upright.
Speed Range:	Minimum - 10 ft/min; Maximum - 150 ft/min. (3 to 46 m/min.)
Maximum User Weight:	400 lbs. (181 kg).
Connectivity:	CSAFE with Fitlinxx Level 3 pending.
Power:	115 VAC \pm 5%, 50/60 Hz, 0.5 amps; or 230 VAC \pm 10%, 50/60 Hz, 0.25 amps. Up to 10 units can be daisy-chained to share one 10-amp outlet.
Other:	Water bottle holder.
Options:	A/V monitor bracket option.

530S Stepper

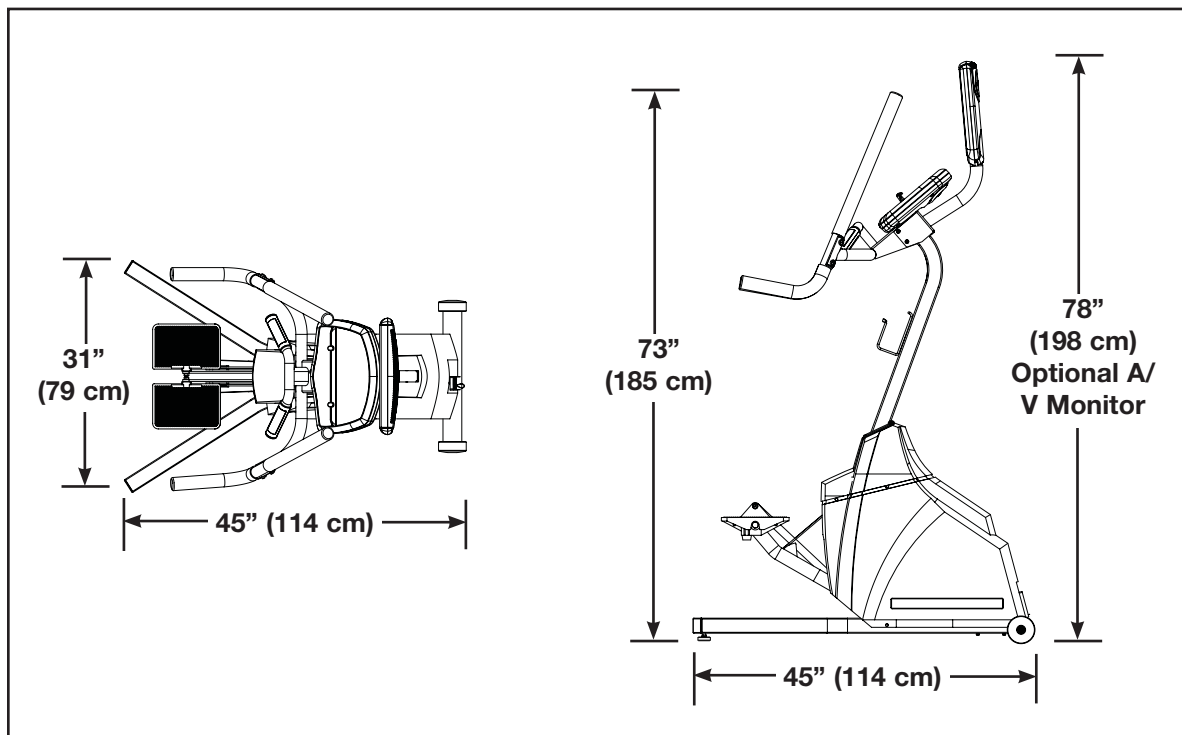

This page intentionally left blank

3 - Operation

Read and understand all instructions and warnings prior to using the unit. See all of the safety related information located in Chapter 1.

Terms and Symbols Used

This section lists some of the common terms and symbols used in this chapter. Other terms and symbols are listed in this chapter as appropriate.

Dormant Mode - The *Dormant Mode* occurs when the unit is not in use. The control panel will display a beating heart when the unit is in *Dormant Mode*.

Program Setup Mode - This begins after pressing any program key. Upon entering a program the LEDs flash, prompting the user to adjust the appropriate settings.

Active Mode - This begins immediately after pressing the **Quick Start** key (*Manual Mode*), or after the *Program Setup Mode*. The beginning of *Active Mode* is marked by a long tone. *Active Mode* continues until you reach the end of a program, press the **Pause/End** key or stop stepping.

Quick Start - This begins by pressing the **Quick Start** key. **Quick Start** skips the *Program Setup Mode* and begins immediately in *Manual Mode*.

Manual Mode - This begins immediately after pressing the **Quick Start** key or after pressing the **Manual** program key. In *Manual Mode* you can customize your workout **Level** and **Time** and enter your **Weight** by pressing those keys. **NOTE:** *Manual Mode features differ from the Manual Program. See the Manual Mode section in this chapter.*

Workout Review - This begins after pressing the **Pause/end** key once, at the end of a program or when you stop stepping for 25 seconds. The workout statistics accumulated during the previous workout session will display for 20 seconds (default setting) or until **Pause/end** is pressed again. **NOTE:** *You can change the 20 second default. See Setting Operation Options in Chapter 5.*

Pause Mode - This begins when the you stop stepping for 25 seconds or when you press **Pause/end** once. While in *Workout Review* you can press the **Quick Start** key to resume your workout in *Manual Mode*. The time, calories burned and other accumulated data is remembered and added to.

▲▼ - These keys adjust **Program, Weight, Time, Level, Age** or **RPM** up or down.

level + - - These keys adjust **Level** up (+) or down (-).

Intended Use

The intended use of this exercise equipment is to aid or improve general physical fitness and exercise. For Household or Commercial use.

530S Stepper

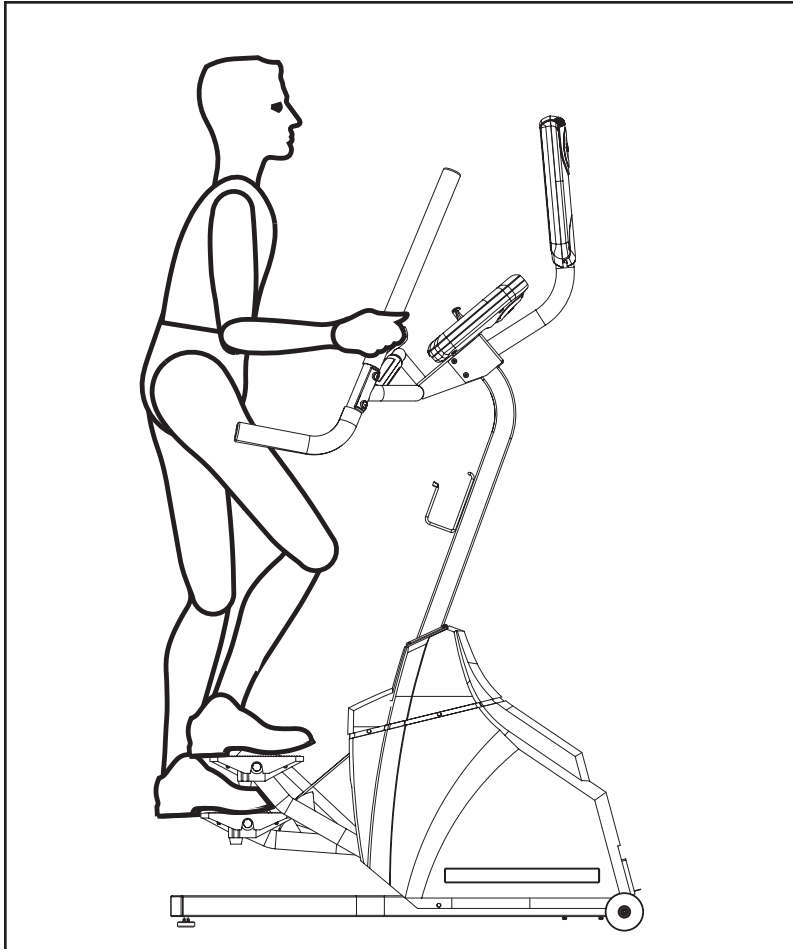

Quick Operation Guide

NOTE: Maximum user weight is 400 lbs. (181 kg).

The following is a quick overview of the operation of the unit. For more information read *Detailed Operation Guide* in this chapter.

1. Hold the handrails to steady yourself while you step onto the pedals.
2. Begin stepping.
3. Press any program key or press **Quick Start** to skip the settings and begin *Manual Mode* immediately.
4. If you pressed a program key to select a program, you will now be prompted for workout **Program, Weight, Time, Level, Age** and **BPM** as appropriate. Adjust these settings with the ▲▼ arrows and press **Enter** to proceed.
5. The unit begins with a long tone then the speed increases or decreases to maintain the desired speed.
6. Press the **Level + -** keys to change the level at any time. The right display will show the current level setting.
7. Press the **Pause/End** key at any time or stop pedaling to end the program.

! WARNING: Wait until pedals come to a complete stop before dismounting.

8. Wait until pedals come to a complete stop before dismounting the unit. Hold the handrails to steady yourself while you step off the unit.

Detailed Operation Guide

NOTE: Maximum user weight is 400 lbs. (181 kg).

1. Hold the handrails to steady yourself while you step onto the pedals.
2. You now have the option to select a program or to select **Quick Start**, skip *Program Setup Mode*, and enter *Manual Mode*.

To select a program, press a program key and follow the prompts. Upon entering a program the LEDs flash, prompting you to adjust the appropriate settings. This is referred to as *Program Setup Mode*. If the **Quick Start** key is pressed now, all defaults for that program will be accepted. After 10 seconds, if no key has been pressed, the first default will be accepted. After another 10 seconds the second default will be accepted and so on until the last default. The program will not enter *Active Mode* until you press the **Enter** or **Quick Start** key.

If you press the **Quick Start** key instead of choosing a program, you will enter *Manual Mode*.

NOTE: No prompts will occur in *Manual Mode*. While in *Manual Mode*, customize your workout **Level** and enter your **Weight** by pressing those keys.

NOTE: Press **Enter** after each adjustment.

3. The unit begins with a long tone. Depending on which program and level you selected, the speed will begin to change.
4. Observe the four displays (See Figure 1):

The lower right display shows the user's current level, then shows speed in feet per minute or meters per minute.

The top center display begins showing your program profile at the left side.

The center display shows statistics or adjustable settings. This scans (every three seconds) through **Distance, Floors, Calories, Calories Per Hour, Mets, Speed and Heartrate**. Press the **Scan** key to toggle this feature on or off.

NOTE: Heart Rate is scanned only when you are holding the contact heart rate grips or using Polar compatible heart rate transmitter. See Figure 1.

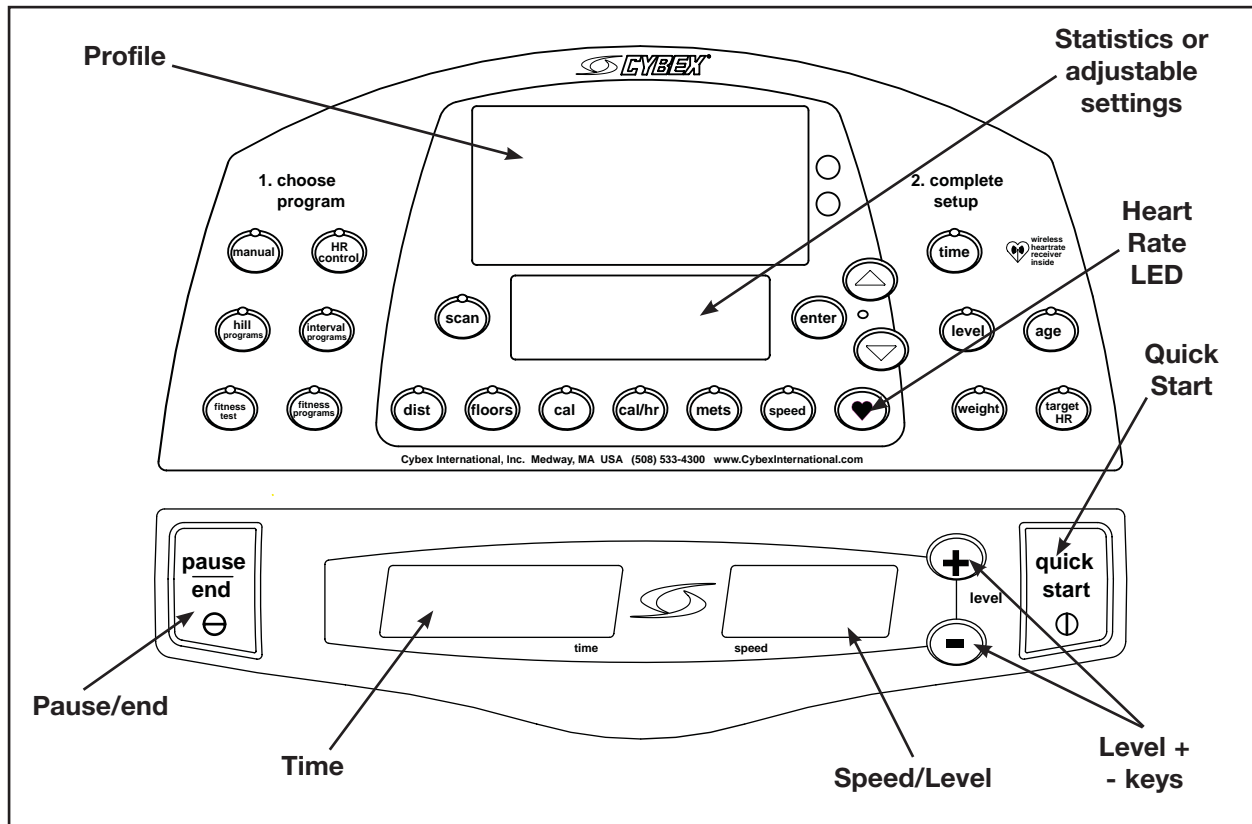

Figure 1

5. Press the **Level + -** keys to change the speed at any time. Pressing the + key will make your workout harder by stepping faster. Pressing the - key will make your workout easier by stepping slower. The right display will show the current speed in increments of 5 from 10 to 150.
6. Press the **Pause/end** key at any time to stop your workout. Press **Pause/end** once to end your workout and begin your *Workout Review*. Press **Pause/end** twice to clear the *Workout Review* and return to *Dormant Mode*.

7. When you complete a program the unit begins a countdown, "3...2...1" and sounds a tone for each count and ends with a long tone. Workout Review displays for 20 seconds (default setting) or until you press the **Pause/end** key.

! WARNING: Wait until pedals come to a complete stop before dismounting.

8. Wait until pedals come to a complete stop before dismounting the unit. Hold the handrails to steady yourself while you step off the unit.
9. The unit returns to *Dormant Mode*.

Stopping The Cybox 530S Stepper

Press **Pause/end** once to pause your workout for 20 seconds (default setting) and to enter the *Workout Review*. As you stop stepping and come to a complete stop all workout settings and data will remain in memory for the pre-selected time. Press the **Quick Start** key within the default setting to continue your workout. If the **Quick Start** key has not been pressed during the 20 second pause, workout data will be cleared and the display will return to *Dormant Mode*.

Press **Pause/end** a second time to interrupt workout data from cycling and to change the display to *Dormant Mode*.

! WARNING: Wait until pedals come to a complete stop before dismounting.

Emergency Dismount: Follow the steps listed below if you experience pain, feel faint or need to stop your unit in an emergency situation:

1. Grip handrails for support.
2. Stop stepping.
3. Continue holding the handrails while you step off the unit.

Control During Operation

Control keys on the display are usable during operation and may be pressed at any time to make adjustments in speed or data readouts.

Changing Level - Press the **Level +** - keys to change the speed in increments of 5. Minimum to maximum speed is from 10-150 feet per minute.







Changing Programs - When changing programs, your data from the previous program will transfer when changing from a program to *Manual Mode* or *Manual Mode* to a program.

Changing Workout Time - Press **Time** to alter the amount of time you plan to workout. You can change **Time** before or during a workout. **NOTE:** The **Max** default time may limit your time. See *Setting Operation Options in Chapter 5*.

Changing Data Readouts - Press **Scan** once to continue to display a set of data. Press **Scan** again and it will continually review each set of data. **NOTE:** The automatic scan is a feature that can be toggled and/or turned on or off. See *Setting Operation Options in Chapter 5*.

Data Readouts

As you exercise, the Cybex 530S Stepper keeps track of the following data:

	Distance - The total accumulated distance, in feet or meters, during your workout. NOTE: Depending on the defaults you've chosen this measurement will show in English or Metric.
	Floors - How many floors you've climbed so far. Each floor is 10 vertical feet (or three meters), or roughly equal to running 100 feet on level ground.
	Calories - The total accumulated calories burned during your workout.
	Calories Per Hour - Calculation of present workloads energy exertion in Calories per Hour.
	Metabolic Equivalent - Relates to the user's energy expenditure. A MET is a basic unit of measurement that is used to compare relative work between individuals and activities. One MET is the amount of oxygen an individual consumes at rest. For example two mets would be twice that amount. If an individual were working at four METs he/she would be consuming oxygen at a rate equal to four times their resting consumption. METs can be used to compare walking on a grade with running or even to cycling and other activities. See <i>The Workout Profile</i> in this chapter for more information.
	Speed - Current stepping speed in feet per minute or meters per minute.
	Heart Rate - Your current heart rate. Heart rate will appear when a signal is introduced. Use either the handgrips for Contact Heart Rate or a Polar compatible heart rate transmitter.

To review accumulated data after a program: The display automatically cycles through your accumulated workout data during the *Workout Review* for 20 seconds (default setting).

Displaying Heart Rate

In order to display your heart rate, you must either use a Polar compatible heart rate transmitter belt (not included) or hold the handgrips to use Contact Heart Rate.

Contact Heart Rate - Hold the handgrips on the handlebar until a heart rate is displayed, typically less than thirty seconds. For best results, hold the handgrips lightly and ensure that your hands contact both the front and back sensors of each grip. **NOTE:** Hold your hands as steady as possible as movement can cause interference on the contacts.

Factors that can interfere with the heart rate signal include:

- excessive movement
- body composition
- hydration
- too loose grip
- too tight grip
- excessive dirt, powder or oil
- resting or leaning on the grips

Contaminant's, such as hand lotions, oils or body powder, may come off on the contact heart rate grips. These can reduce sensitivity and interfere with the heart rate signal. Therefore, ensure you have clean hands when using the contact heart rate.

Polar Compatible Reception - To use this feature, a Polar compatible heart rate transmitter belt must be worn. To view heart rate continuously, press the **Scan** key when the Heart LED is lit or press the **Heart** key.

Use of Programs

! WARNING: Obtain a medical exam before beginning any exercise program. Begin comfortably with a lower level and progress with higher levels as you become acclimated.

You may choose from five different program categories. HR Control provides direct selection of target heart rate. *Fitness Test* predicts a persons VO₂ max level. Three of the program categories (Hill, Interval, and Fitness) each provide three different profiles, with twenty one levels of difficulty for a choice of one hundred and eighty nine different pre-programmed options.

You may also use *Manual Mode*. With this unique combination of programs, you can tailor your workout to achieve exactly the fitness goals you desire, including: weight loss, conditioning, endurance or maintenance of overall health. The program choices are summarized as follows:

Quick Start	No profile	28 levels	Skip setup, control speed and time as you go.
Manual	No profile	28 levels	Enter time desired. Control resistance as you go.
HR Control	No profile	No levels	Program controls speed and resistance.
Hill Programs	3 Profiles	21 levels	Enter time desired. Level dictates resistance.
Interval Programs	3 Profiles	21 levels	Enter time desired. Level dictates resistance.
Fitness Test	No profile	No levels	Program controls speed and resistance.
Fitness Programs	3 Profiles	21 levels	Enter time desired. Level dictates resistance.

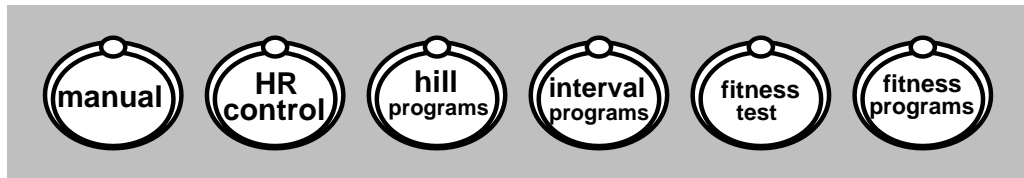

Manual Mode

Overview

Manual Mode is available both through **Quick Start** and through the **Manual** program where it includes the program time and user weight adjustment.

Manual Mode is not a pre-programmed workout. Instead, it allows you to choose your settings as you workout. You may choose your settings according to how you feel or your endurance level. Since you remain in control, *Manual Mode* may be the best choice for beginners or for those who have not worked out in a long time.

When you workout in *Manual Mode*, be sure to include a three-to-five minute warm-up and cool-down period. You can warm-up by setting a low speed and then gradually increase the speed to the target for your workout. Reverse this process for your cool-down period, lowering the speed gradually.

Press the **Quick Start** key to workout in *Manual Mode*. To increase or decrease the speed while in *Manual Mode* use the **Level + -** keys.

Selecting the Manual program key and completing setup results in the Manual Program Active State. On entry, a long tone indicates the beginning of the session. The dot matrix has a horizontal weight of fifteen seconds per dot. Vertical weight is mode specific. Follow the instructions in the Setup and Assembly chapter to learn how to change setup default values.

The Workout Profile

The Workout Profile matrix in the center of the display uses columns of lights to show the progress of your workout. The height of the column represents Watts, specifically the highest Watts you reached in that period. Each column represents 1 minute of your total workout time when in *Manual Mode* and 15 seconds in every other program.

Meaning of METS

What are METS?

The term MET is the abbreviation for Metabolic Equivalent. A Metabolic Equivalent is the oxygen (energy) consumption of an individual at rest. When expressed as a number larger than one, it is the ratio of oxygen consumption between that activity and the oxygen consumption at rest.

One MET is equal to an oxygen consumption of about 3.5 milliliters per kilogram body weight per minute.

As a practical tool, the MET allows for a general comparison of differing activities and relative intensities. Activities are often classified as light, moderate or vigorous, but may also be in any one of the three categories based on how hard the individual works relative to their capacity.

- Activities classified as light use less than three METs
- Activities classified as moderate require three to six METs
- Activities classified as vigorous require greater than six METs

NOTE: See *METS* chart on next page.

Cybex 530S Owner's Manual

Sport/Fitness Activities	METs	Activities of Daily Living	METs
Treadmill 3 mph, 4% incline	3.5	Cooking, standing	2.0
Treadmill 5 mph, 0% incline	3.5	Cleaning gutters	5.0
Golf, walking and carrying clubs	4.5	Watching television	1.0
Cybex Arc Trainer™, incline 5, resistance 50, 100 strides/min.	12.5	Gardening w/ heavy power tools	6.0
Soccer, competitive	10	Mowing lawn	5.5
Ice Skating, 9 mph or less	5.5	Fire fighter, general	12.0
Skiing, general	7.0	Shoveling, > 16 lb./min.	9.0
Skiing, cross county, > 8.0 mph	14.0	Carrying small children	3.0
Yoga	2.5	Using crutches	5.0
Circuit training, minimal rest	8.0	Walking up stairs	4 - 7
Mountain biking	8.5	General housework	3 - 4

Heart Rate Control

Program Overview

The Heart Rate Control program is interactive. By selecting a predetermined heart rate, the stepper will adapt the speed to keep the user's heart rate at that level. The stepper increases and decreases the speed to maintain constant power as it attempts to meet and hold your target heart rate.

This program is exceptionally useful for those individuals just starting out as well as the athlete. By maintaining the predetermined heart rate, the user is less likely to over or under exert themselves thereby ensuring they get all they should out of their training. Over time, the user will notice that as their fitness level improves and using a given time and heart rate that they will see more ground covered, more calories burned and a higher MET level during the program.

Fitness Test

The Fitness Test is based on the Dickson protocol and should be used with a Polar® compatible heart rate transmitter.

The Fitness Test starts at 30 feet per minute, then increases the speed by five feet each minute, up to 45 feet per minute for males and 50 feet per minute for females. After the test, 530S Stepper calculates and displays your fitness score. The score is an estimate of your VO₂ Max (it measures the rate at which you can supply oxygen to your cells). The table at the end of this section will help you interpret your score.

Your score will be an accurate measure of your condition only if your heart rate is at its resting level when you begin.

1. Make sure you are wearing a Polar heart rate transmitter and it is working properly.
2. Hold the handrails to steady yourself while you step onto the pedals.
3. Press the **Fitness Test** key.
4. The display will show "LBS" or "KGS", adjust your weight using the ▲ and ▼ arrow keys and press **Enter**.

NOTE: The 530S Stepper uses your weight to calculate your score, be sure to allow for your clothing and shoes. In general, add about five pounds (2.7 kgs.) to your base weight to get an accurate reading.

5. The display will show "M ♂" (male) or "F ♀" (female). Select "M ♂" or "F ♀" by using the ▲ and ▼ arrow keys and press **Enter**.

6. The test will now start with a long tone.

NOTE: You cannot change the speed setting during the test. The dot matrix display shows a horizontal bar, starting across the bottom for stage 1 and ending with a bar across the top for the final stage.

7. At the end of the test, the 530S Stepper displays your score (estimated VO2 Max). See Figure 3.

Fitness Classifications						
	Age	Low	Fair	Average	Good	High
Women	20-29	< 24	24-30	31-37	38-48	49 +
	30-39	< 20	20-27	28-33	34-44	45 +
	40-49	< 17	17-23	24-30	34-41	42 +
	50-59	< 15	15-20	21-27	28-37	38 +
	60-69	< 13	13-17	18-23	24-34	35 +
Men	20-29	< 25	25-33	34-42	43-52	53 +
	30-39	< 23	23-30	31-38	39-48	49 +
	40-49	< 20	20-26	27-35	36-44	45 +
	50-59	< 18	18-24	25-33	34-42	43 +
	60-69	< 16	16-22	23-30	31-40	41 +

Figure 3

Fitness Test Reminders: To obtain an accurate assessment of your physical condition, we suggest you consider a number of factors which may influence your heart rate when planning your test. These factors include:

- amount of sleep the previous night.
- amount of caffeine, alcohol, and/or nicotine consumed and the time elapsed since consumption.
- time of day of the test.
- time since last meal.
- time since last exercise.

For best results, we suggest you perform the fitness test on three consecutive days under similar conditions and average the three scores.

Hill Programs - Rolling Hills

Program Overview

The Rolling Hills program is designed to give the user the experience of climbing in a hilly terrain. Very similar to the *Hills* program with more time spent at each level. This program uses intervals of moderate speed to simulate relatively flat areas and intervals of substantially greater speed to simulate steeper grades. Likewise the two-minute work segments are intended to tax the users capabilities, while the two-minute rest allows for recuperation and allows for repeated work segments. See Figure 4.

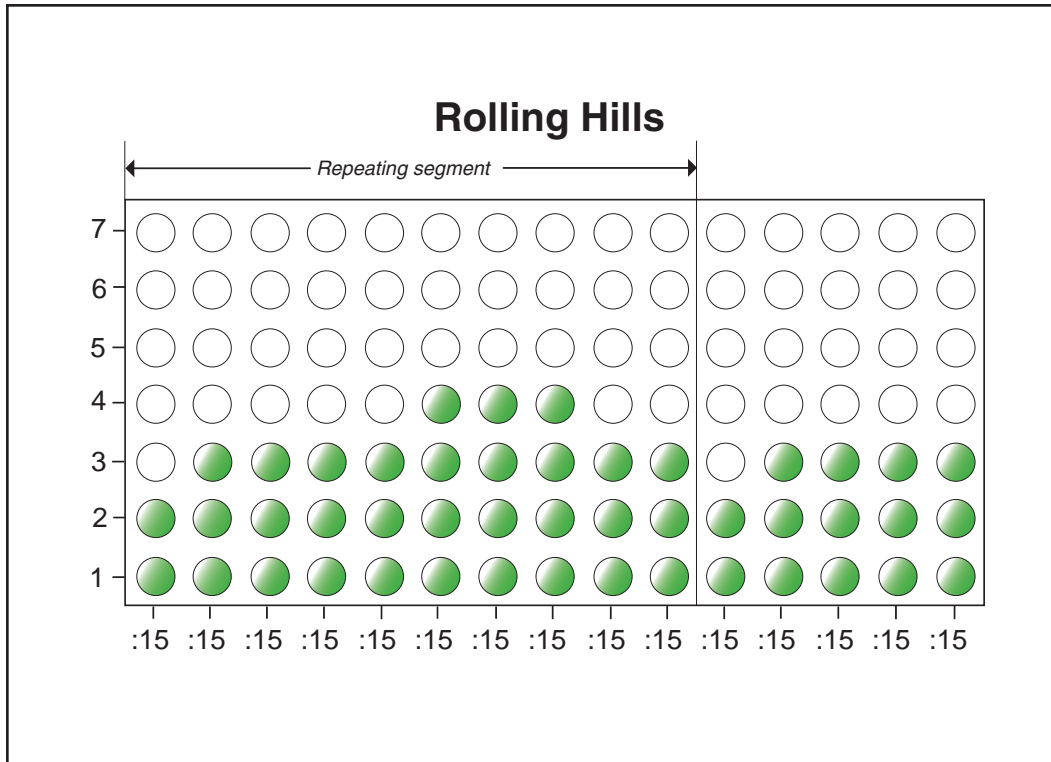

Figure 4

Hill Programs - Hills

Program Overview

The Hills program is designed to give the user the experience of climbing in a hilly terrain. This program uses intervals of moderate speed to simulate relatively flat areas and intervals of substantially greater speed to simulate steeper grades. Likewise the two-minute work segments are intended to tax the users capabilities, while the two-minute rest allows for recuperation and allows for repeated work segments. See Figure 5.

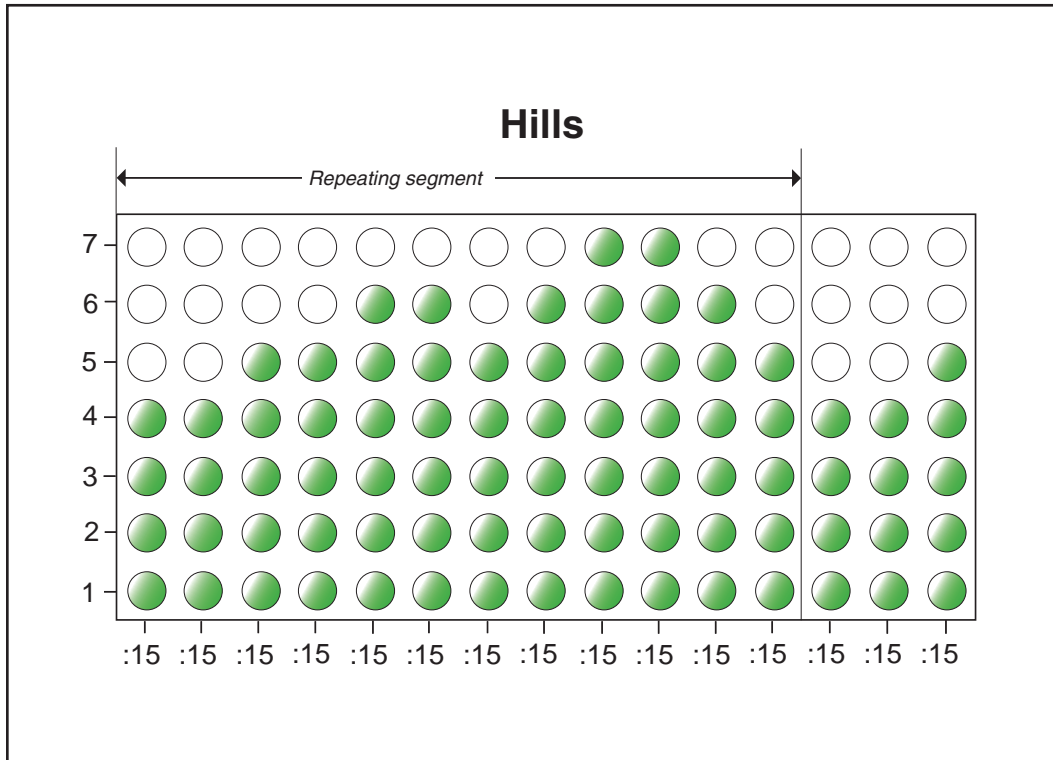

Figure 5

Hill Programs - The Divide

Program Overview

The Divide program begins with a modest level of speed and then gradually ramps to its peak and then remains at that level for 45 seconds before ramping back down to its beginning level.

See Figure 6.

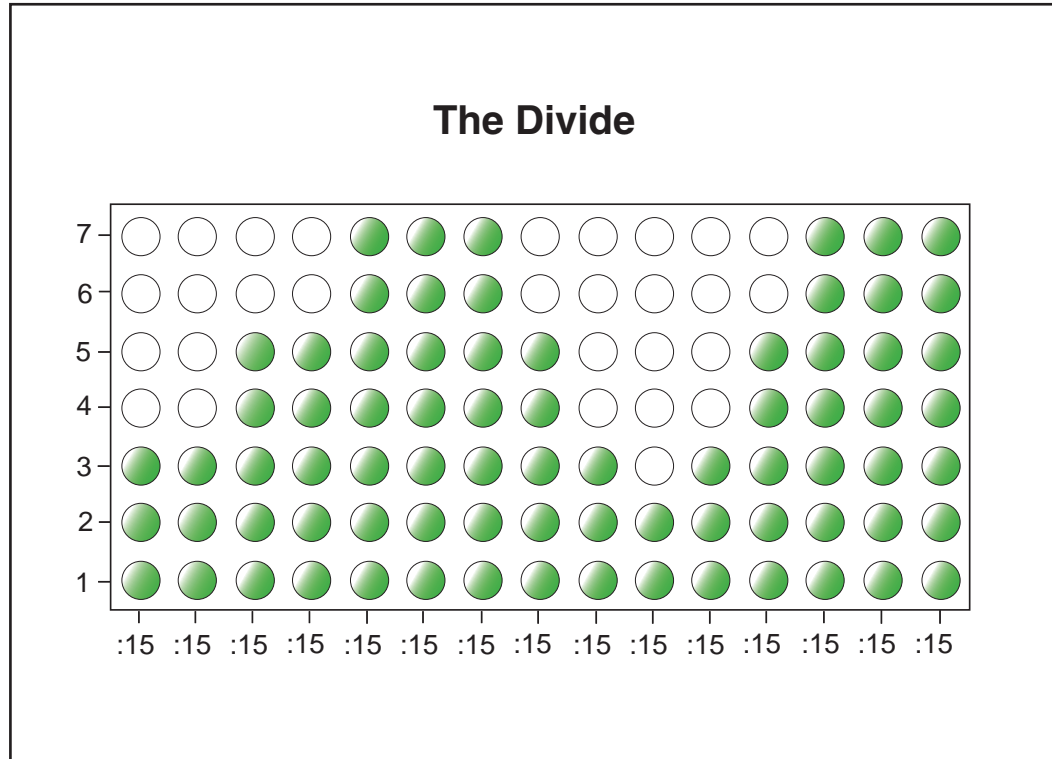

Figure 6

Interval Programs - Interval

Program Overview

The Interval program utilizes a 1:2 (work:rest) ratio with the work period lasting for 30 seconds. This allows for moderate and balanced taxation of both the aerobic and anaerobic energy systems. As such this program is useful to those who desire improving both their aerobic and anaerobic capabilities. See Figure 7.

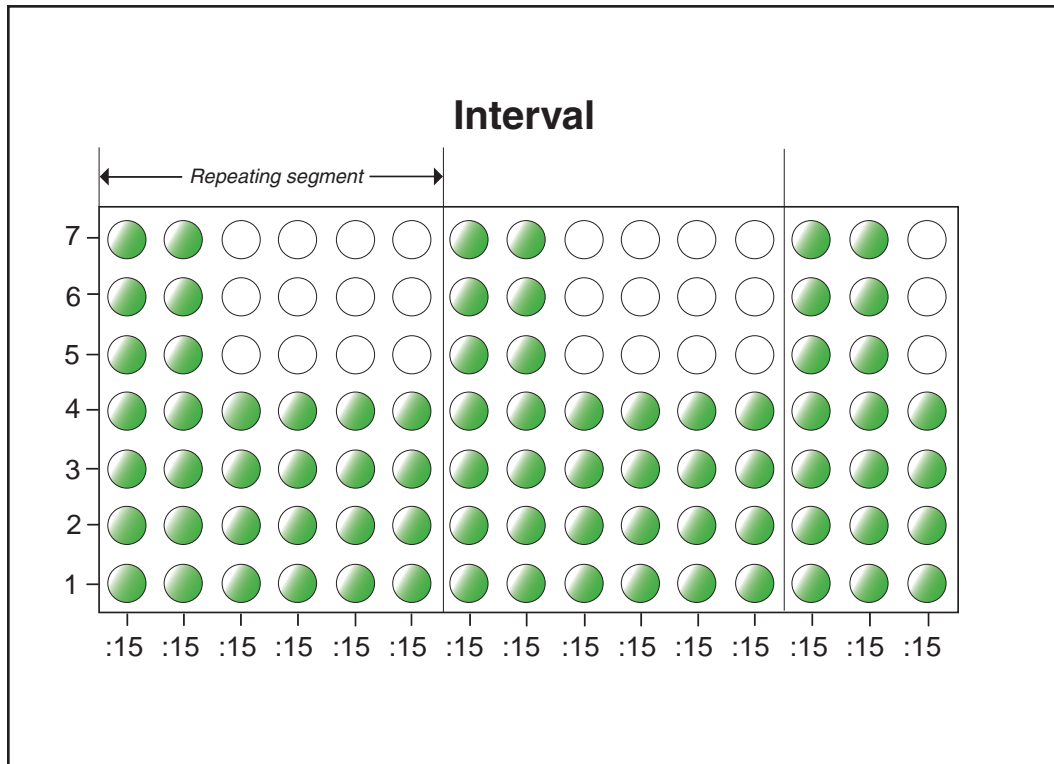

Figure 7

Interval Programs - Sprint

Program Overview

The Sprint program is designed with the specific goal of taxing the anaerobic energy system and encouraging maximal power development. This program uses a 1:3 (work:rest) ratio using 15 second intervals. The work period displays a high workload goal during work segments to encourage the user to work maximally while the rest periods show very low workloads to encourage recuperation. See Figure 8.

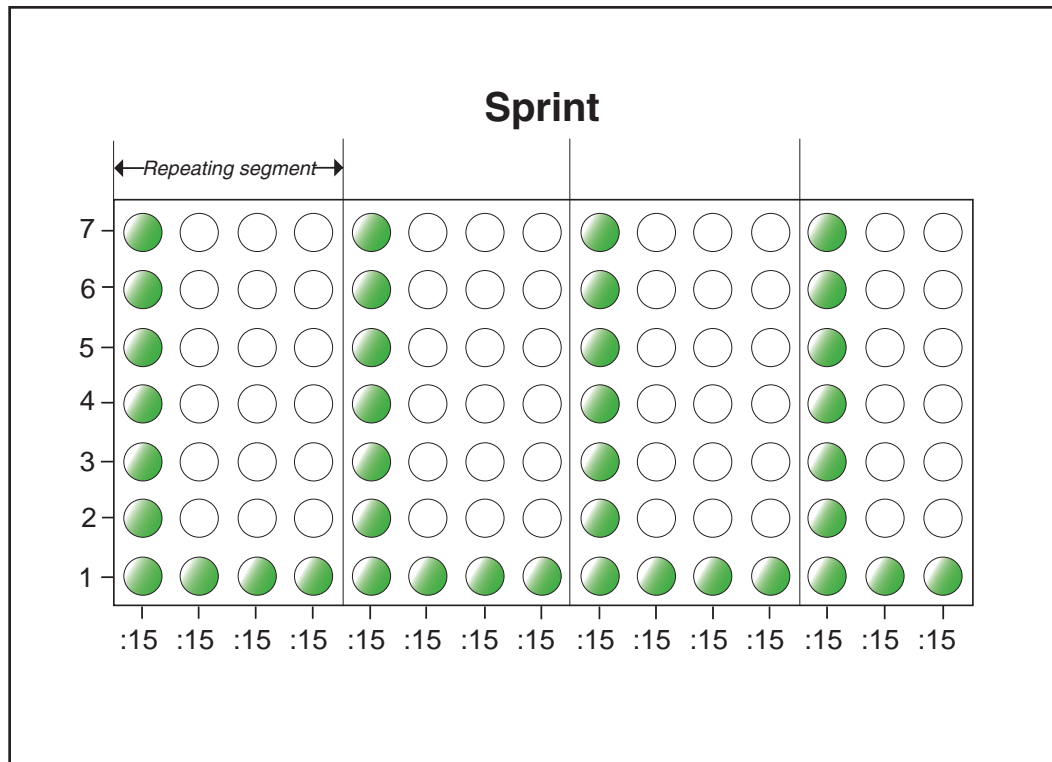

Figure 8

Interval Programs - Ramps

Program Overview

The Ramps program is designed to encourage the user to work progressively towards their anaerobic energy system. The Ramps program mode will allow the user to maintain step speed as the user fatigues. When the user is not capable of attaining the targeted workload, the stepper adjusts the load accordingly. See Figure 9.

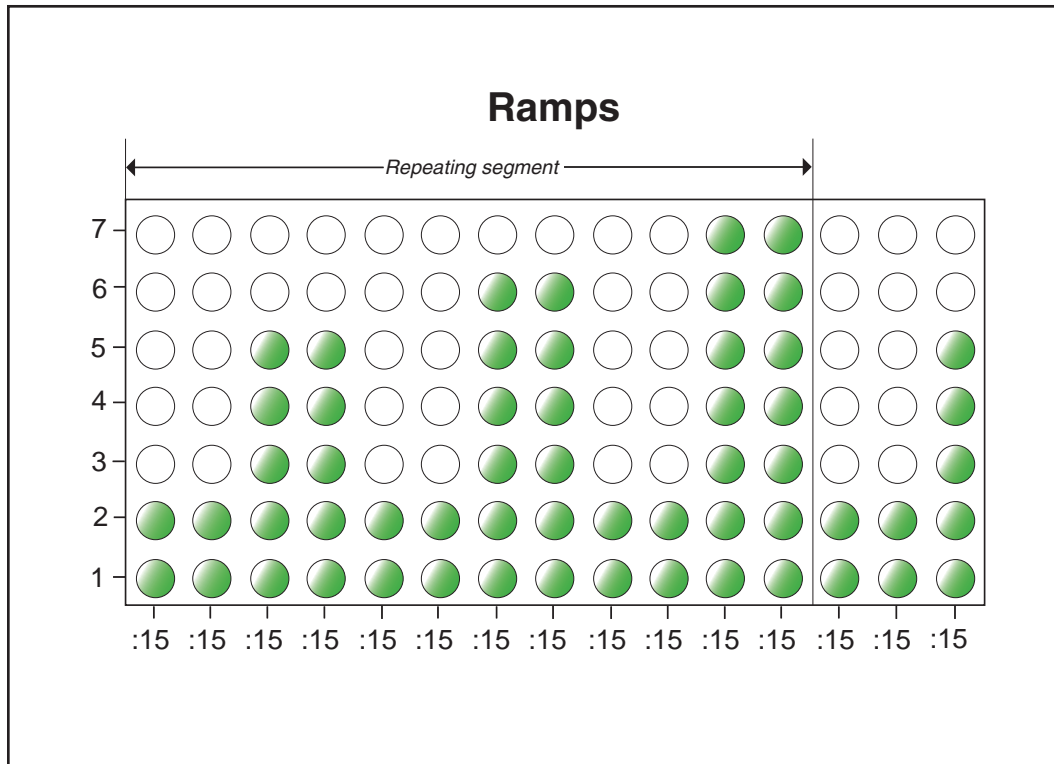

Figure 9

Fitness Programs - Weight Loss

Program Overview

The Weight Loss program is designed for low to medium intensity training that the user can sustain for an extended period of time. It builds from a low intensity baseline to include segments of higher speed. The different speed levels provide for periods of higher expenditure and training without the introduction of undue fatigue allowing the user to perform for longer periods of time. See Figure 10.

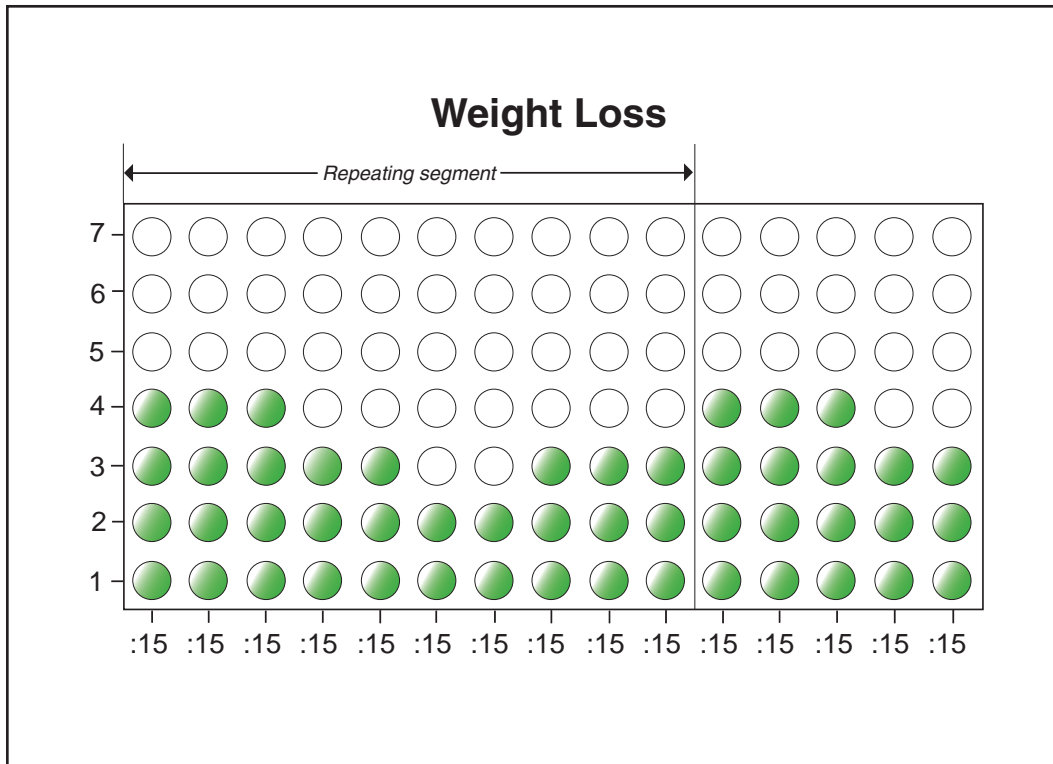

Figure 10

Fitness Programs - Cardio

Program Overview

The Cardio program is designed for experienced users that desire a high intensity cardiovascular training experience. The two-minute work interval with high speed ensures that the aerobic energy system is completely taxed, while the subsequent two-minute rest interval allows for recovery enabling a repeat at the higher work rate. See Figure 11.

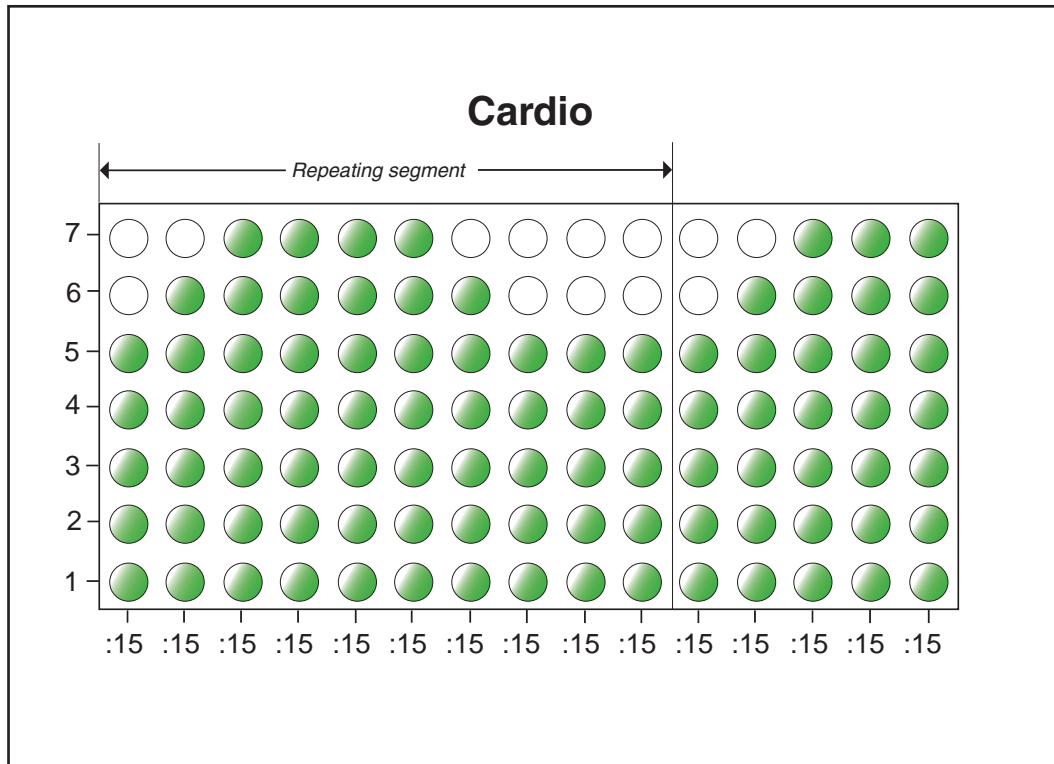

Figure 11

Fitness Programs - Endurance

Program Overview

The Endurance program begins with a modest level of speed and then gradually ramps to its peak and then remains at that level for 45 seconds before ramping back down to its beginning level. See Figure 12.

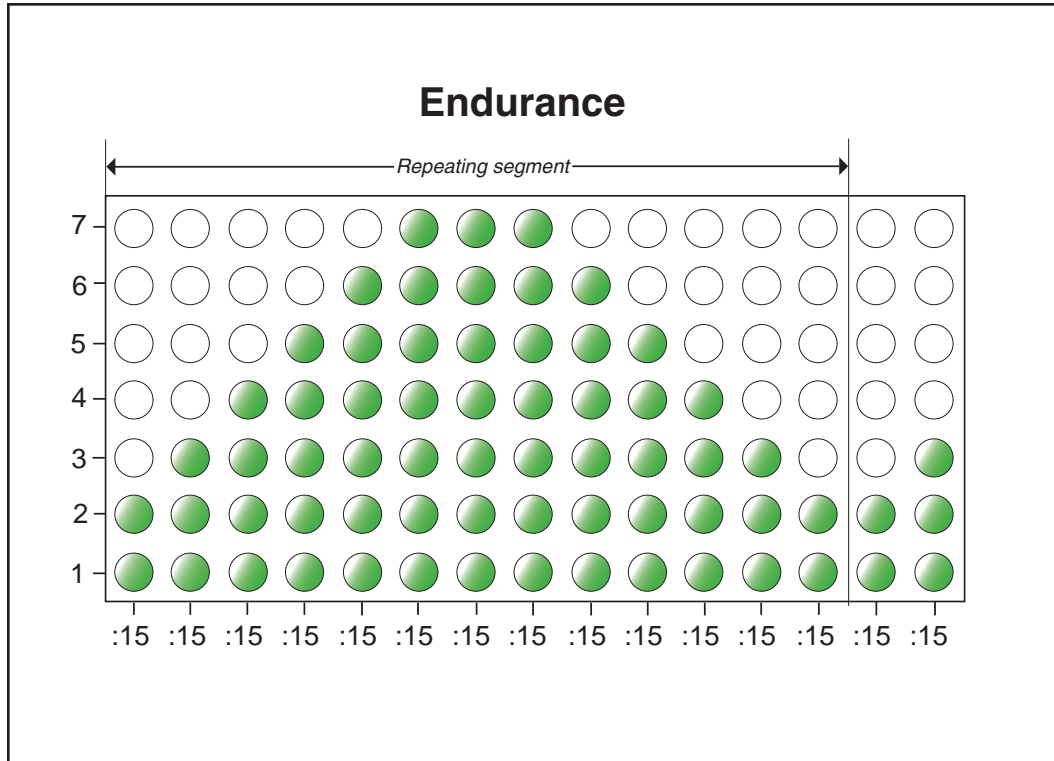

Figure 12

This page intentionally left blank.

4 - Preventive Maintenance

Warnings

All warnings listed in this chapter are as follows:

! WARNING: All maintenance activities shall be performed by qualified personnel. Failure to do so could result in serious injury.

! WARNING: To prevent electrical shock, be sure that the unit is unplugged from the electrical outlet before performing any cleaning or maintenance procedures.

Regular Maintenance Activities

! WARNING: All maintenance activities shall be performed by qualified personnel. Failure to do so could result in serious injury.

Preventive maintenance activities must be performed to maintain normal operation of your unit. Keeping a log of all maintenance actions will assist you in staying current with all preventive maintenance activities.

NOTE: Worn or damaged components shall be replaced immediately or the unit removed from service until the repair is made.

NOTE: Cybex is not responsible for performing regular inspection and maintenance actions for your unit. Instruct all personnel in equipment inspection and maintenance actions and also in accident reporting/recording.

Cleaning Your Cybex 530S

! WARNING: To prevent electrical shock, be sure that the unit is unplugged from the electrical outlet before performing any cleaning or maintenance procedures.

When cleaning your unit spray a mild cleaning agent, such as a water and dish soap solution, on a clean cloth first and then wipe the unit with the damp cloth.

NOTE: Do not spray cleaning solution directly on the unit. Direct spraying could cause damage to the electronics and may void the warranty.

After Each Use - Wipe up any liquid spills immediately. After each workout, use a cloth to wipe up any remaining perspiration from the handrails and painted surfaces.

Be careful not to spill or get excessive moisture on the console and display overlays, as this might create an electrical hazard or cause failure of the electronics.

As Needed - Vacuum any dust or dirt that might accumulate under or around the unit.

To clean inside the unit, remove the Phillips head screws securing the covers in place. Use a vacuum attachment or hand vacuum to clean the exposed areas and remove dirt and debris off of internal components.

Use a *dry* cloth to wipe all exposed areas. Replace the covers and secure them with the screws when finished.

Lift the rear of the unit and roll it back from its present position to vacuum the floor area underneath the unit. When finished, return the unit to its normal position.

Contact Heart Rate Grips - Contaminants, such as hand lotions, oils or body powder, may come off on the contact heart rate grips. These can reduce sensitivity and interfere with the heart rate signal. It is recommended that the user have clean hands when using the contact heart rate. Clean the grips using a cloth dampened with a cleaning solution containing alcohol. The grips are the only part of the unit you should use a cleaning solution containing alcohol.

Drive Cable Maintenance

! WARNING: *Serious injury could occur if these inspection and maintenance actions are not observed.*

Inspect the drive cables regularly for signs of wear and replace them every six to eight months with Cybex-supplied replacement cables. See Figure 1 for location of drive cables.

Follow the procedure below to ensure that the cables are in good condition. **NOTE:** *If a cable has cracks or appears worn, it must be replaced immediately by a qualified service technician.*

Tools Required

- None

! WARNING: *To prevent electrical shock, be sure that the unit is unplugged from the electrical outlet before performing any cleaning or maintenance procedures.*

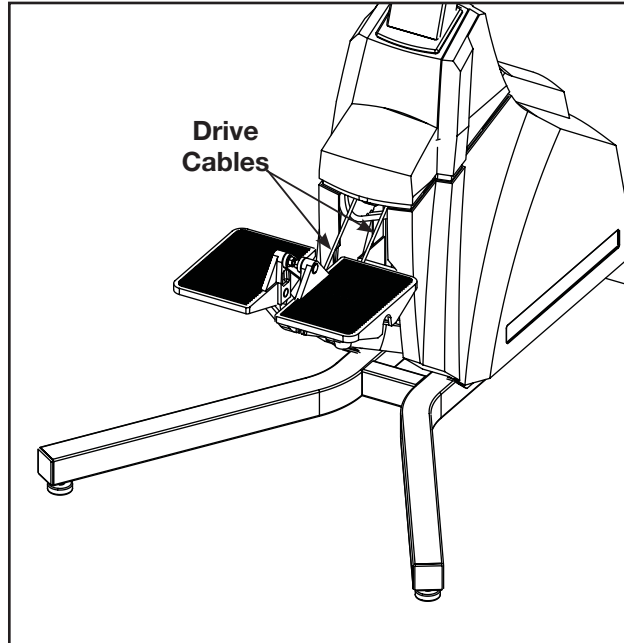

Figure 1

1. Read and understand this **Drive Belt Maintenance** section thoroughly before proceeding to step 2.
2. Disconnect the external power source.
 - A. Locate the on/off (I/O) power switch on the front of the stepper. Toggle it to the on (I) position.
 - B. Unplug the stepper from the power outlet.
3. Inspect the drive cables.
 - A. While kneeling next to the stepper push one pedal all the way to the floor.
 - B. Inspect the drive cable for signs of wear, cracking or discoloring.
 - C. Carefully return the pedal to it's starting position.
 - D. Repeat procedure for other drive cable.

Environment

Static Electricity - Depending upon where you live, you may experience dry air, causing a common experience of static electricity. This may be especially true in the winter time. You may notice a static build-up just by walking across a carpet and then touching a metal object. The same can hold true while working out on your unit. You may experience a shock due to the build-up of static electricity on your body and the discharge path of the unit. If you experience this type of situation, you may want to increase the humidity to a comfortable level through the use of a humidifier.

Humidity - The unit is designed to function normally in an environment with a relative humidity range of 30% to 75%.

NOTE: *Do not install or use the unit in an area of high humidity, such as in the vicinity of a steam room, sauna, indoor pool or outdoors. Exposure to extensive water vapor, chlorine and/or bromine could adversely affect the electronics as well as other parts of the machine.*

Temperature - The unit is designed to functionally normally in an environment with an ambient temperature range of 50°F (10°C) to 104°F (40°C) degrees.

Storage

Humidity - The unit can be shipped and stored in an environment with a relative humidity range of 10% to 90%.

NOTE: *Do not store the unit in an area of high humidity, such as in the vicinity of a steam room, sauna, indoor pool or outdoors. Exposure to extensive water vapor, chlorine and/or bromine could adversely affect the electronics as well as other parts of the machine.*

Temperature - The unit can be shipped and stored in an environment with an ambient temperature range of 32°F (0°C) and 140°F (60°C) degrees.

5 - Setup and Assembly

Warnings

All warnings listed in this chapter are as follows:

! WARNING: *Use extreme caution when assembling the unit. Failure to do so could result in injury.*

! WARNING: *Always use proper lifting methods when moving heavy items.*

! WARNING: *Be sure that all electrical requirements are met as indicated in the specifications at the front of the manual and at the beginning of this chapter prior to proceeding.*

! WARNING: *Wait until all moving parts come to a complete stop before dismounting.*

Choosing and Preparing a Site

Before assembling the unit you must select a suitable site and have the proper electrical outlet power available for optimum operation and safety. See the *Electrical Power Requirements* section (located on the next page) for direction in locating your voltage requirements.

The area you select for the unit should be well lit and well ventilated. Locate the unit on a structurally sound and level surface. Allow enough clearance for safe access and passage during use of the unit.

Humidity - The unit is designed to function normally in an environment with a relative humidity range of 30% to 75%.

NOTE: *Do not install or use the unit in an area of high humidity, such as in the vicinity of a steam room, sauna, indoor pool or outdoors. Exposure to extensive water vapor, chlorine and/or bromine could adversely affect the electronics as well as other parts of the machine.*

Temperature - The unit is designed to functionally normally in an environment with an ambient temperature range of 50° F (10° C) to 104° F (40° C) degrees.

See Chapter 4 for information regarding storage of the unit.

Electrical Power Requirements

The power requirements for the unit are a grounded circuit rated for one of the following: 115 VAC \pm 5%, 50/60 Hz; or 230 VAC \pm 10%, 50/60 Hz. Contact your electrician to ensure the power supply complies with local building codes. **NOTE:** Do not use a ground plug adapter to adapt the 3-prong power cord plug to a non-grounded electrical outlet.

Up to ten units can be daisy-chained together for single outlet use. Use daisy chain power supply cord, Part# AW-14004. The daisy-chain outlet is rated at 750 Watts.

Assembling the Cybex 530S Stepper

! WARNING: Use extreme caution when assembling the unit. Failure to do so could result in injury.

! WARNING: Always use proper lifting methods when moving heavy items.

Tools Required

- 1/2" Open end wrench
- 5/32" Allen wrench
- 3/16" Allen wrench
- Phillips head screwdriver

NOTE: The words "left" and "right" denote the user's orientation.

1. Read and understand all instructions thoroughly before assembling the unit.

NOTE: Each step number in the assembly instructions tells you what you will be doing. The lettered steps following each step number describe the procedure required. Do not continue with step 2 until you have carefully read all of the assembly instructions.

2. Verify you have received the correct package.

- A. Read the sticker on the outside of the box and verify that the model number and language is what you ordered.

3. Unpack and verify the contents of the boxes.

- A. Lift up and remove the cardboard sleeve that surrounds the unit.
- B. Verify that you have the color that you ordered by looking at the paint.

Cybex 530S Owner's Manual

C. Check to be sure that the following items are present. Check off (✓) each item as you find it. See Figure 1. If any of the parts are missing contact Cybex Customer Service.

Item	Qty	Part Number	Description
<input type="checkbox"/> 1	1	AX-19022	Base with covers attached
<input type="checkbox"/> 2	1	AF-19057	Display upright
<input type="checkbox"/> 3	1	AX-62011B	Display upright collar
<input type="checkbox"/> 4	1	AF-18796	Console Handrail
<input type="checkbox"/> 5	2	AX-19050	Handrail (Left or Right)
<input type="checkbox"/> 6	1	AC-19056-4	Console
<input type="checkbox"/> 7	1	HX-19167	Bottle cage (in box)
<input type="checkbox"/> 8	1	AW-14007	Power cord (in box)
<input type="checkbox"/> 9	1	AX-19202	Hardware pack (in box)
<input type="checkbox"/> 10	1	LT-18938-4	Owner's Manual (in box)
<input type="checkbox"/> 11	1	LT-19246	Assembly poster
<input type="checkbox"/> 12	1	LT-19247	Warranty sheet

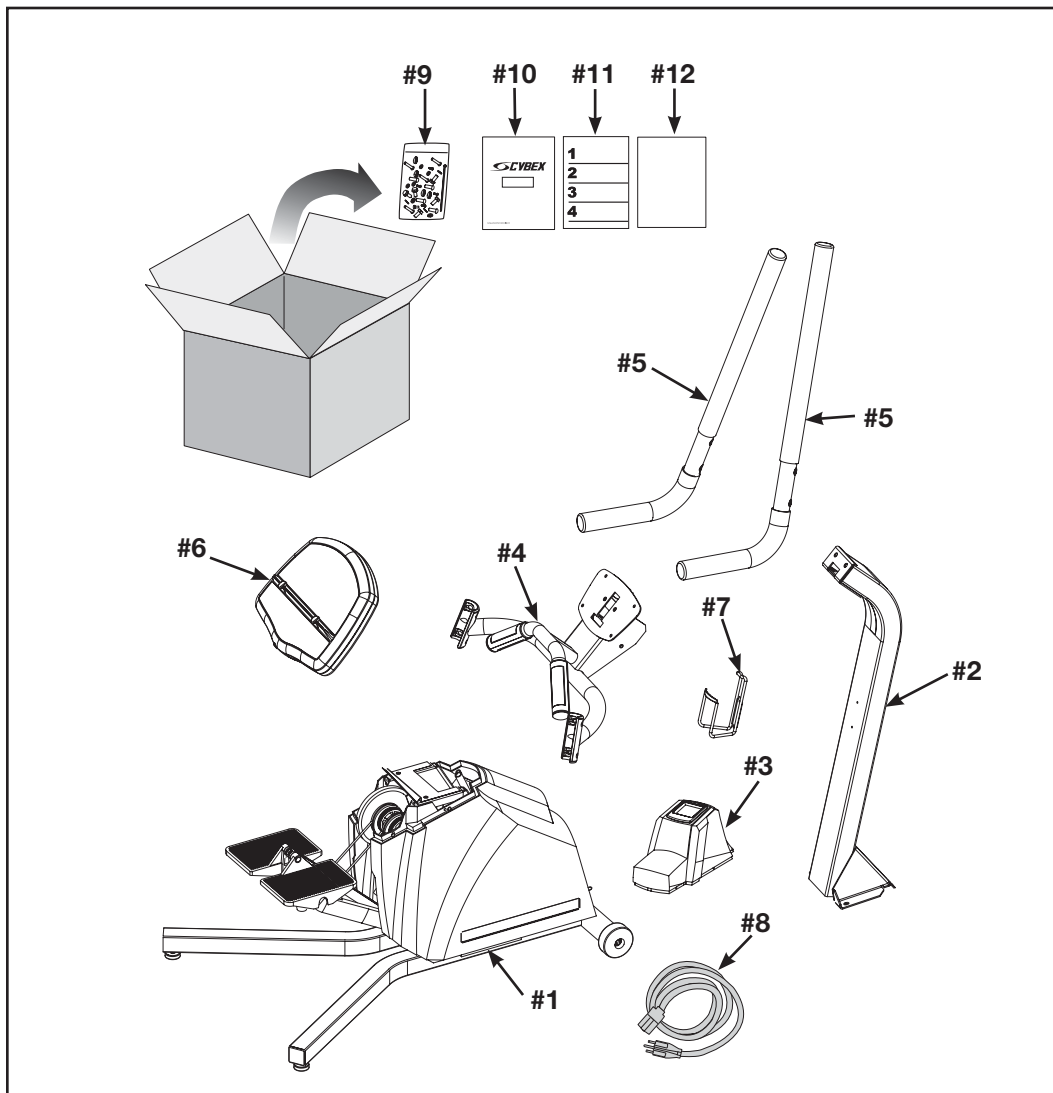
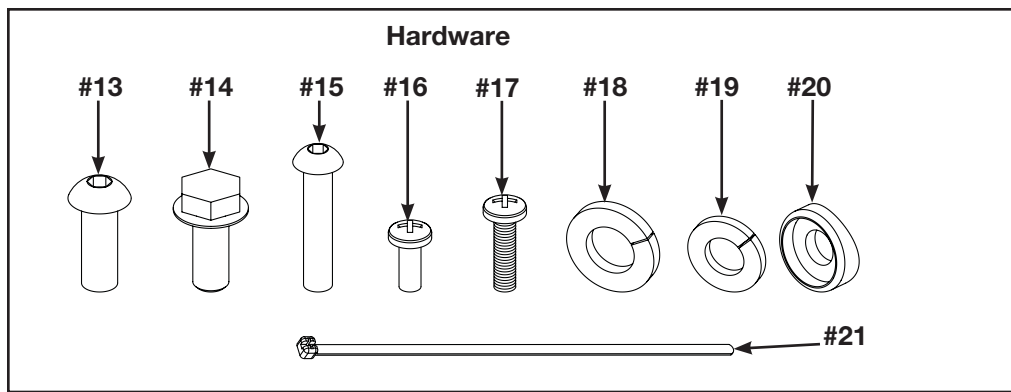

Figure 1

Cybex 530S Owner's Manual

D. Check off () each item in the hardware pack as you find it. See Figure 2.

Item	Qty	Part Number	Description
<input type="checkbox"/> 13	8	HS-16950	Screw 5/16-18 x 7/8", Lg HX Soc Btn
<input type="checkbox"/> 14	8	HS-17544	Bolt, SLFTP, 5/16-18 x .75", HXHD BLK, ZN
<input type="checkbox"/> 15	4	HS-18127	Bolt, 1/4-20 X 1.25", BHCS, SS, BLK
<input type="checkbox"/> 16	2	HS-41006	Screw, 10-24 X 1/2", Phillips
<input type="checkbox"/> 17	4	HS-41109	Screw, 10-24 X 3/4", Pan Hd
<input type="checkbox"/> 18	16	HW-00165	Washer, Lock, 5/16", Zinc
<input type="checkbox"/> 19	4	HW-00180	Washer, Lock, 1/4", Zinc
<input type="checkbox"/> 20	8	HW-54000	Washer, Shoulder, Tube
<input type="checkbox"/> 21	1	EH-00472	Wire Tie, 3.9"



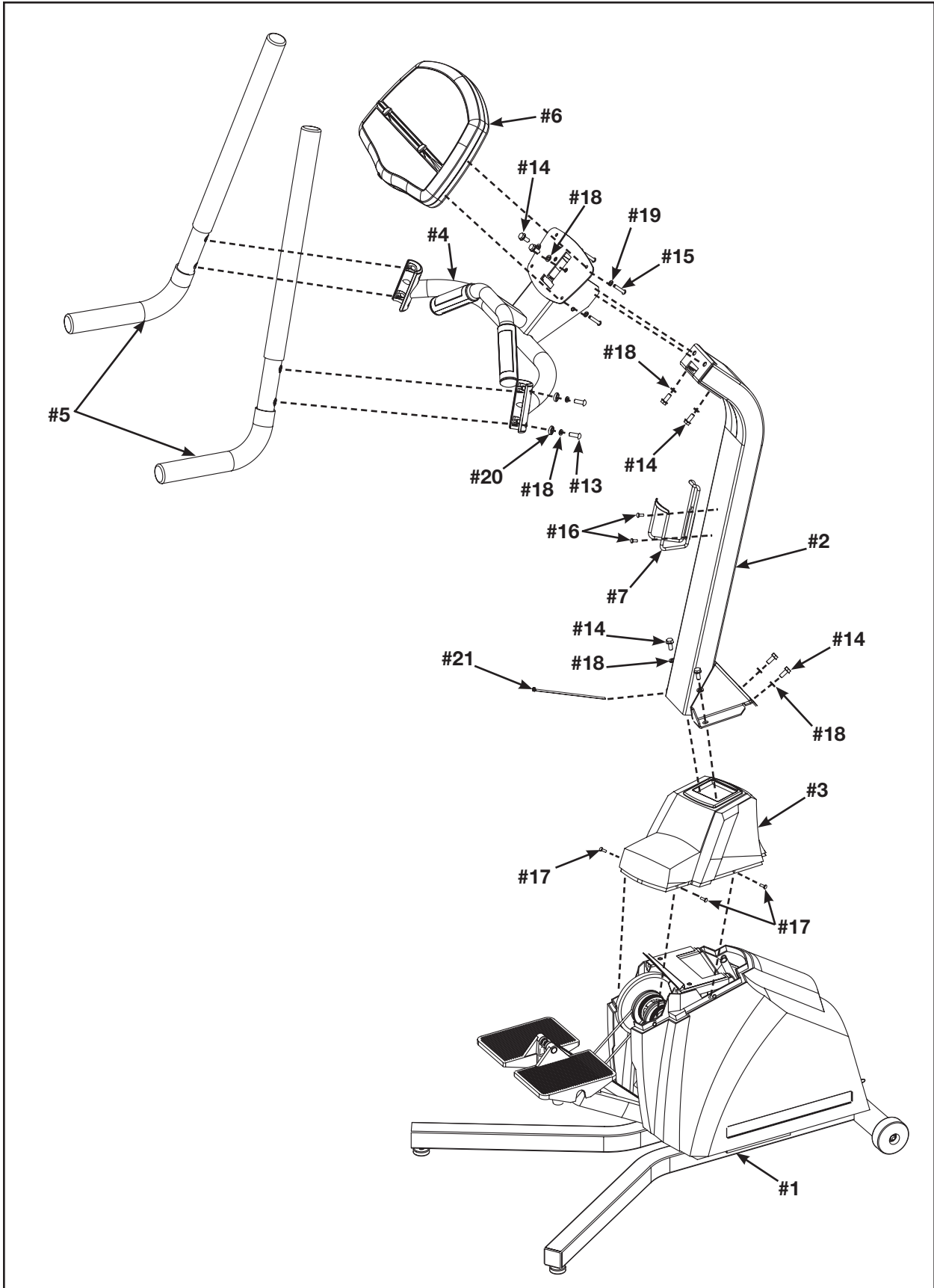

Figure 2

! WARNING: Always use proper lifting methods when moving heavy items.

4. Lift and move the unit

- A. Lift and move or roll the unit using the front transport wheels to the location where you intend to leave it. Use proper lifting methods.

5. Attach the Display Upright to Base Assembly.

NOTE: If attaching the A/V option, refer to the 530S A/V bracket installation instructions (supplied with the A/V bracket).

- A. Locate the display upright (#2), four screws 5/16-18 X .75" (#14) and four washers 5/16" (#18). See Figure 3.
- B. Attach the display cable from the bottom of the display upright (#2) to the end of the display cable on the base frame (#1). Make sure the cable connector latches snap into place. See Figure 4.
- C. Using a 1/2" open end wrench secure the display upright (#2) to the base (#1) using four screws 5/16-18 x .75" (#14) and four washers 5/16" (#18). See Figure 3.
- D. Locate the wire tie (#21) and secure the display cable to the upright (#2). See Figure 3.

6. Attach the Display Upright Collar.

- A. Locate the display upright collar (#3) and four screws 10-24 x 3/4" (#18).
- B. Slide the display upright collar (#3) down over the display upright (#2) and attach to the base (#1) using four screws 10-24 x 3/4" (#17), as shown in Figure 5.

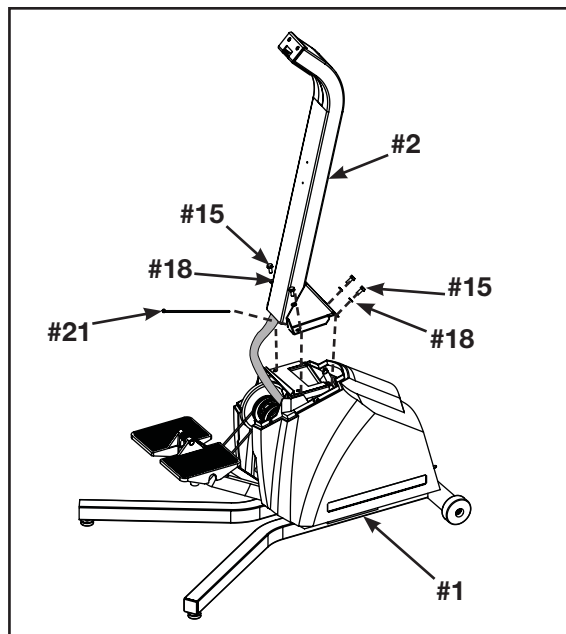

Figure 3

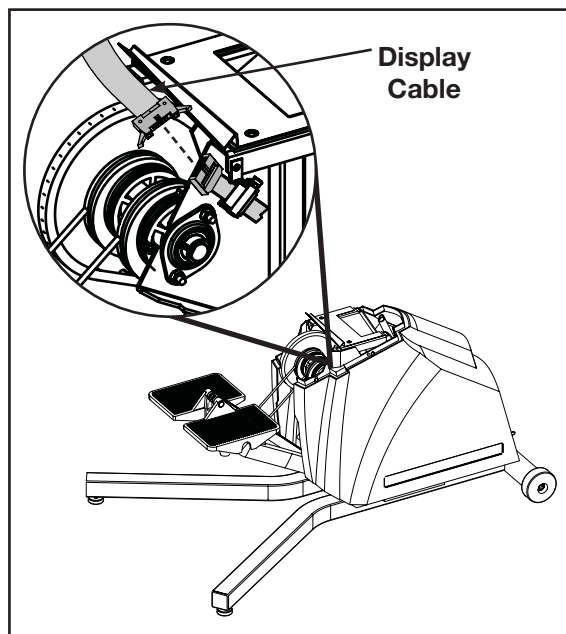

Figure 4

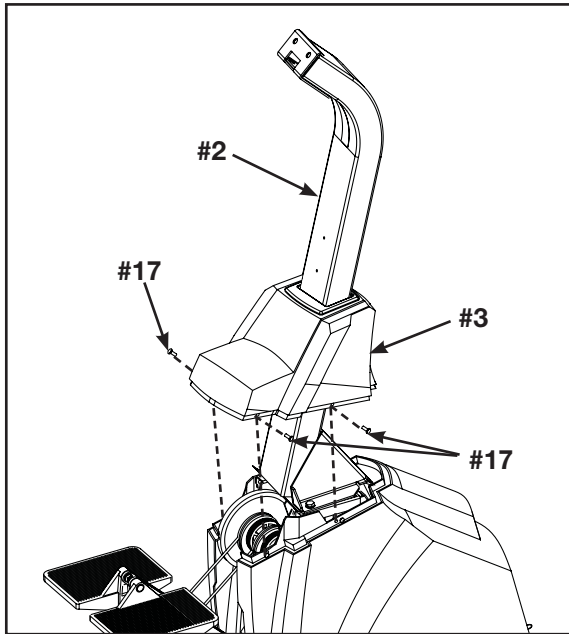

Figure 5

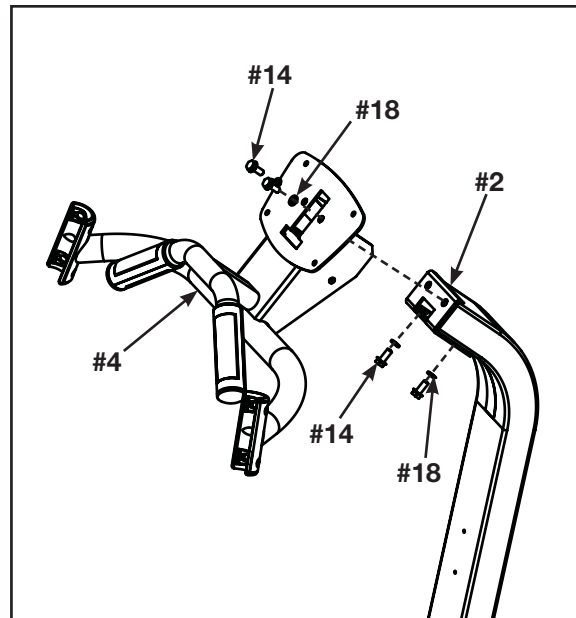

Figure 6

7. Attach the Display Handrail.

- A. Locate the display handrail (#4), four screws 5/16-18 x .75" (#14) and four washers 5/16" (#18). See Figure 6.
- B. Using a 1/2" open end wrench secure the display handrail (#4) to the display upright (#2) using four screws 5/16-18 x .75" (#14) and four washers 5/16" (#18).

8. Attach the Handrails.

- A. Locate the two handrails (#5), four screws 5/16-18 x 7/8" (#13), four washers 5/16" (#18) and four shoulder washers (#20). See Figure 7.
- B. Using a 3/16" allen wrench secure the handrails (#5) to the display handrail (#4) using the four screws 5/16-18 x 7/8" (#13), four washers 5/16" (#18) and four shoulder washers (#20). See Figure 7.

9. Attach the Display Console to the Display Handrail.

- A. Locate the display console (#6) and four screws 1/4-20 x 1.25" (#15). See Figure 8.
- B. Using a Phillips head screwdriver, remove the four screws securing the console front to the console back. See Figure 8.

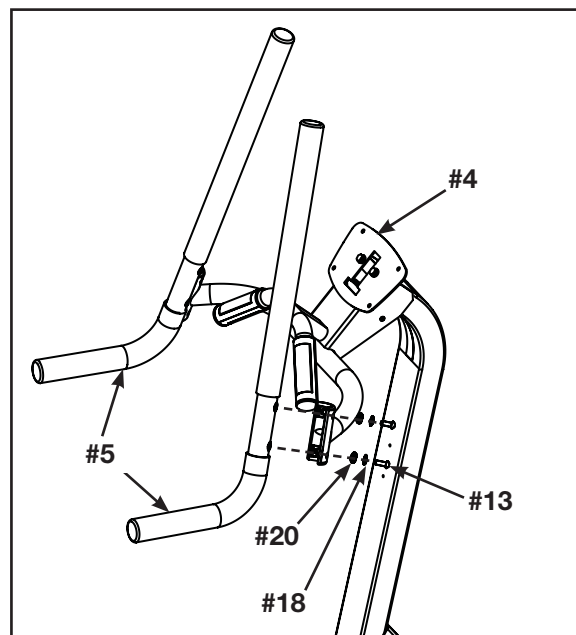

Figure 7

- C. Using a 5/32" allen wrench secure the console back to the console upright (#4) using four screws 1/4-20 x 1.25" (#15) and four washers 1/4" (#19). See Figure 9.
- D. Locate the display cable, contact heart rate cable and ground wire. Insert the cables into the display board. See Figure 10.
- E. Place the console front in the correct position on the console back.
- F. While being sure not to pinch any cables, use a Phillips head screwdriver to tighten the four screws securing the console front to the console back. See Figure 8.

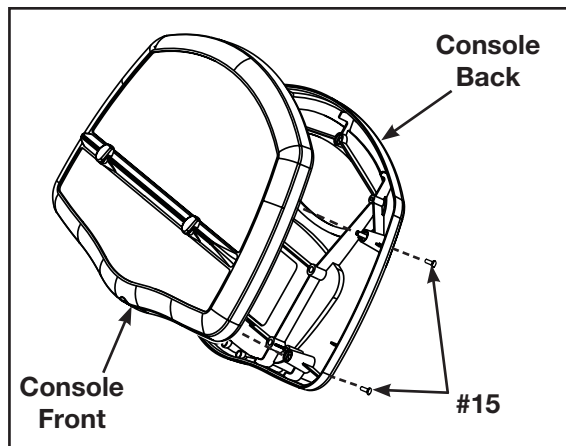

Figure 8

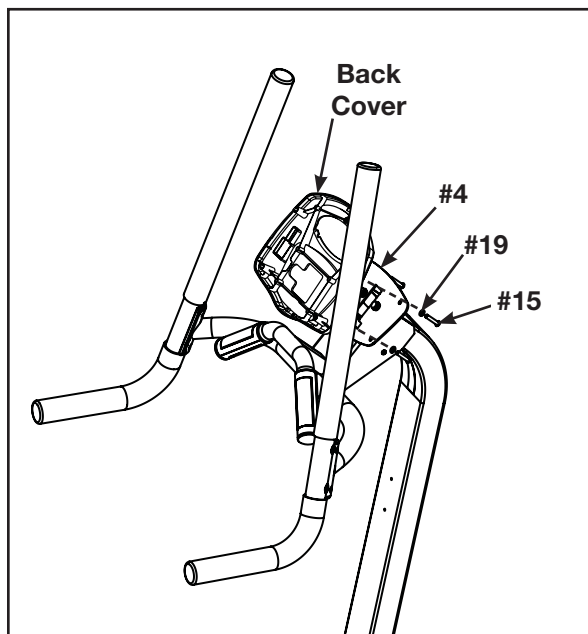

Figure 9

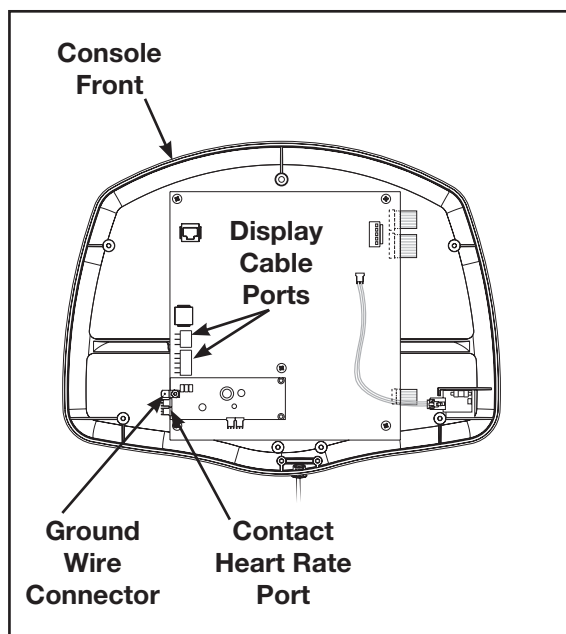

Figure 10

10. Attach the Bottle Cage.

- A. Locate the bottle cage (#7) and two screws 10-24 x 1/2" (#16).
- B. Using a Phillips head screwdriver secure the bottle cage to the console upright (#2) using two screws 10-24 x 1/2" (#16). See Figure 11.

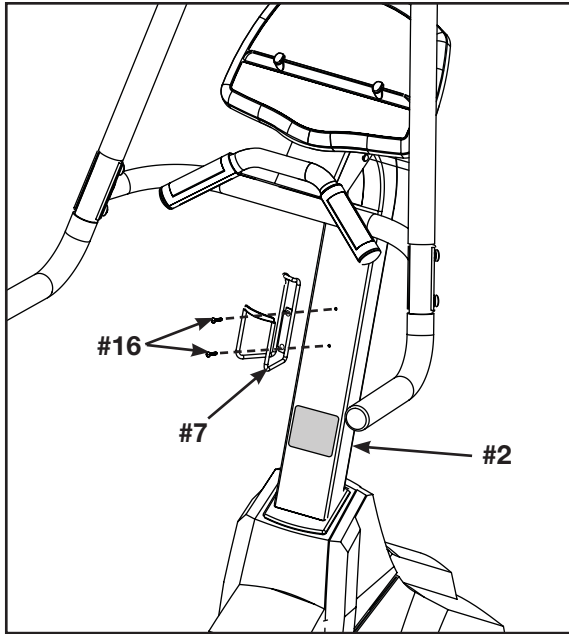

Figure 11

11. Level the unit.

- A. Confirm that the unit is on a level surface. See steps 8B - 8D for leveling.

! WARNING: Always use proper lifting methods when moving heavy items.

- B. Carefully lay the stepper on its side to gain access to the leveling feet.
- C. Locate the leveling feet at the rear of the unit. See Figure 12.
- D. Using your hands, adjust the leveling feet up or down until the unit is level.

12. Connect the power cord.

- A. Plug the power cord (#8) into the inlet near the front of the unit. **NOTE: Do not plug the power cord into an outlet at this time.** See Figure 13.

13. Visually inspect the unit.

- A. Carefully examine the unit to ensure that the assembly is correct and complete.
- B. Proceed to *Testing the Operation* section.

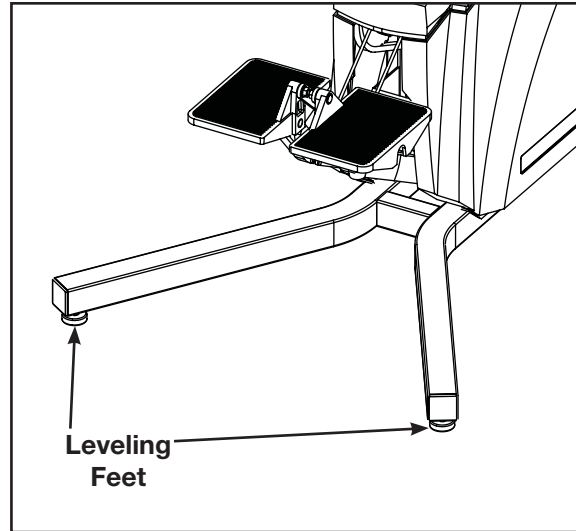

Figure 12

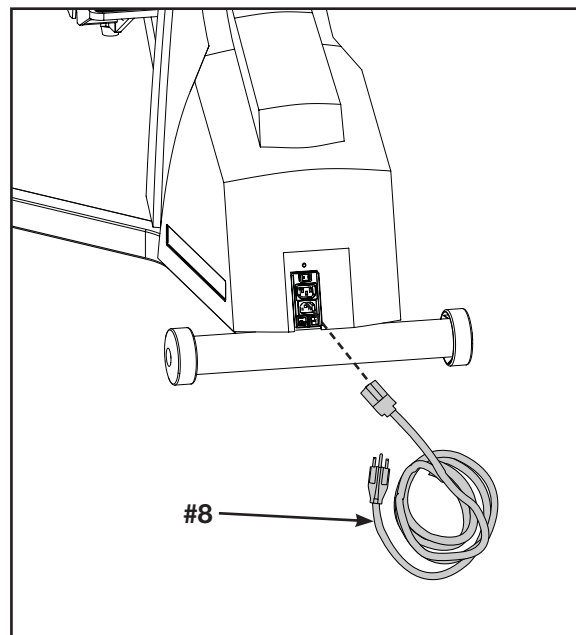

Figure 13

! WARNING: *Be sure that all electrical requirements are met as indicated in the specifications at the front of the manual and at the beginning of this chapter prior to proceeding.*

Testing the Operation

Use the following instructions to test the full resistance of the unit.

1. Plug the power cord into a power outlet from a grounded circuit as described under *Electrical Requirements* in this chapter. **NOTE:** *Coil up the remainder of the power cord and place it out of the way.*

NOTE: *Cybex recommends that the unit be unplugged when not in use.*

2. Locate the on/off (I/O) power switch on the front of the stepper. Toggle it to the on position (I).
3. Observe that the control panel will illuminate and be in the *Dormant Mode*.
4. Hold the handrails to steady yourself while you step onto the pedals.
5. Begin stepping.
6. Press the **Quick Start** key. The unit begins with a long tone then the speed increases to correspond to the program that you selected.
7. Run the unit through its full resistance range. First press the **Level +** key until the unit reaches its highest speed (the display will show "150"). Then press the **Level -** key until the unit reaches its lowest speed; the display will show "10". As you step, you will feel the speed change.
8. Press **Pause/End** twice to end the workout review and return the display to *Dormant Mode*.

! WARNING: *Wait until all moving parts come to a complete stop before dismounting.*

9. Wait until pedals come to a complete stop before dismounting the unit. Hold the handrails to steady yourself while you step off the unit.

Setting Operation Options

1. Enter *Test Mode* by holding down any key while turning on (I) power. The display will read "Step".

NOTE: After changing any value, you must press **Enter** to save that value. When you press enter the display will read "updt" (updated) to confirm your selection.

2. Press the **Time** key to set options, change values with ▲ and ▼ keys and press **Enter** to save your selection. Each time you press **Time** the next set of data is displayed in the following order:

Unit — Choices are "Eng" or "Euro" measurements. English is the default.

Scan — This turns on or off the data readout scan (unless a specific data key is pressed during a workout). Default is on.

Time — This is the default time for time based programs if a user doesn't re-set **Time**. For example, if you press **Time** you can decrease or increase the set workout time up to the amount that the **Max** time is set. Choices are between 20 minutes and 60 minutes. Default is 60.

Max: — This is the maximum amount of time the stepper can run per use. You can limit the users time or choose "none" for unlimited time. Choices are between none and 120 minutes; default is 60. **NOTE:** If the **Max** time is limited too much it may be difficult for the user to reach their goals. For example, a user may not be able to burn 300 calories if you limit their **Max** time to 20 minutes.

Idle (or Workout Review/Pause Time): — This is how long the treadmill retains and displays your current workout data during a pause in the workout or after a workout. Choices include: 10 seconds; 20 seconds; 30 seconds, 40 seconds; 1 minute and 5 minutes; default is 20 seconds.

Remember: You must press **Enter** after changing a value for that value to be stored.

3. To exit *Test Mode* press the **Pause/end** key twice.

Your stepper is now ready for use. Follow the instructions in the *Operation* chapter to learn how to operate the stepper.

This page intentionally left blank

6 - Customer Service

Contacting Service

Hours of phone service are Monday through Friday from 8:30 a.m. to 6:00 p.m. Eastern Standard Time.

For Cybex customers living in the USA, contact Cybex Customer Service at **888-462-9239**.

For Cybex customers living outside the USA, contact Cybex Customer Service at **508-533-4300** or fax **508-533-5183**.

Order parts and find information on the web at www.cybexinternational.com or by e-mail at techhelp@cybexintl.com.

Serial Number

Your serial number can be found on the back of the console upright, See Figure 1.

NOTE: Do not use the serial number located on the base in front of the pedals.

For your convenience record your serial number below so that you will have it ready if you call Cybex Customer Service.

Serial Number _____

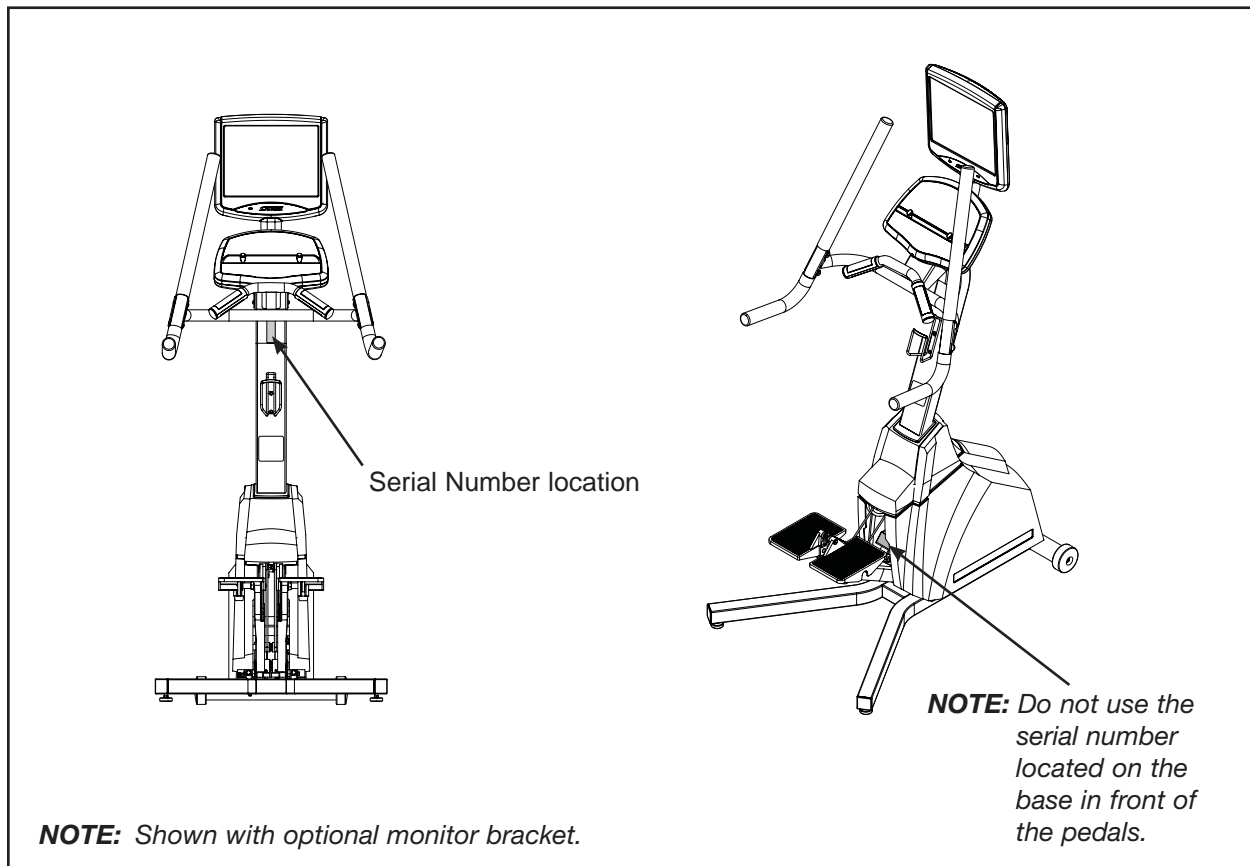

Figure 1

Return Material Authorization (RMA)

The Return Material Authorization (RMA) system outlines the procedures to follow when returning material for replacement, repair or credit. The system assures that returned materials are properly handled and analyzed. Follow the following procedures carefully.

Contact your authorized Cybex dealer on all warranty-related matters. Your local Cybex dealer will request an RMA from Cybex, if applicable. Under no circumstances will defective parts or equipment be accepted by Cybex without proper RMA and an Automated Return Service (ARS) label.

1. Call the Customer Service hotline listed on Page 6-1 for the return of any item that is defective.
2. Provide the technician with a detailed description of the problem you are having or the defect in the item you wish to return.
3. Provide the model and serial number. *The serial number is located on the front of the unit as shown in Figure 1.* The serial number begins with a letter, for example: R09-101331100.
4. At Cybex's discretion, the technician may request that you return the problem part(s) to Cybex for evaluation and repair or replacement. The technician will assign you an RMA number and will send you an ARS label. The ARS label and RMA number must be clearly displayed on the outside of the package that contains the item(s) to be returned. Include a description of the problem, the serial number of the unit and the name and address of the owner in the package along with the part(s).
5. Forward the package through UPS to Cybex.
Attn: Customer Service Department
Cybex International, Inc.
10 Trotter Drive
Medway, MA 02053

NOTE: *Merchandise returned without an RMA number on the outside of the package or shipments sent C.O.D. will not be accepted by the Cybex receiving department.*

Damaged Parts

Materials damaged in shipment should not be returned for credit. Shipping damages are the responsibility of the carrier (UPS, Federal Express, trucking companies, etc.).

Apparent Damage - Upon receipt of your shipment, check all boxes carefully. Any damage seen with a visual check must be noted on the freight bill and signed by the carrier's agent. Failure to do so will result in the carrier's refusal to honor your damage claim. The carrier will provide you with the required forms for filing such claims.

Concealed Damage - Damage not seen with a visual check upon receipt of a shipment but noticed later must be reported to the carrier as soon as possible. Upon discovery of the damage, a written or phone request to the carrier asking them to perform an inspection of the materials must be made within ten days of the date of delivery. Keep all shipping containers and packing materials: they will be needed as part of the inspection process. The carrier will provide you with an inspection report and the necessary forms for filing a concealed damage claim. Concealed damage is the carrier's responsibility.

Ordering Parts

Visit www.cybexinternational.com to shop for parts online or fax your order to **508-533-5183**. To speak with a customer service representative, call **888-462-9239** (for customers living within the USA) or **508-533-4300** (for customers outside the USA).



Cybex will void warranty if non-Cybex replacement parts are used.

Parts List

ITEM NO.	QTY.	PART NO.	DESCRIPTION
1	1	AX-62066B	Assy, Cover, 530S, BLACK
2	6	HN-42035	Nut, U-Type, 10-24, Relief Notch, Tinnerman
3	12	HS-41006	Screw, 10-24 x 1/2", Phil Pan
4	2	HX-40030	End Caps, 2 x 2", Frame, Rear
5	2	AW-45031	Cable, Drive
6	2	PL-40008	Foot, Rear Leveling, 3/8 - 16 x 1-11/16" Dia.
7	1	AX-19021	Switchplate Assy.
10	3	HX-43206	Retaining Ring, External, 25mm
11	4	HW-40031	Washer, Thrust, Crank Arm
12	1	FM-51460	Axle, Flywheel
13	2	HW-40004	Wave Spring Washer, 1" ID
14	2	AX-61357	Pedal Assy.
15	1	HB-44024	Bushing, 3/4 ID x 7/8 OD x 5/8", Large Flange
16	1	HB-44026	Bushing, Pedal Screw
17	1	HB-44025	Bushing, 1/2 ID x 19-32 OD x 1/2", Large Flange
18	2	HS-41109	Screw, 10-24 x 3/4"
19	10	HW-43011	Washer, 3/16" Dia.
20	1	HX-05127	Bumper, Under Pedal
21	6	HX-19091	Ring, Retaining, .75" Shaft
22	4	HW-43025	Washer, 3/4 ID x .124", Thick Nylon
23	3	HW-40005	Washer, Wave, 3/4" ID
24	1	HB-44009	Bearing, Olite 3/4 x 15-16 x 3/4"
25	2	AX-61032	Parallel Arm Assy.
26	1	AX-19512-Q	Lower Power Control Board, 115/220 VAC, RoHS
27	2	HX-40002	Washer, Spring, 3/8" DIA. Curved
28	2	HB-44027	Bearing, Thrust, 3/8 x 1/16"
29	2	HW-43028	Washer, 5/8"
30	2	HN-42030	Nut, 5/8-16", Hex Jam, SS
31	4	HW-43031	Washer
32	1	HX-46003	Sprocket, Flywheel
33	4	HB-44015	Bearing with two Seals
34	3	HW-43021	Washer, 3/4 OD x 1/2" ID
35	4	HX-43196	Retaining Ring, E Type
37	1	HB-44007	Clutch Roller, 25 mm
40	6	HS-41077	Screw, 5/16-18 x 1-1/2" HHCS, G5
41	4	HN-42007	Nut, Jam, 3/8-16", Zinc
42	16	HW-43042	Washer, 5/16", 8 mm
43	8	HB-44053	Bearing, Flange
44	4	HB-44052	Bearing, Flange, Clutch Shaft
45	4	HN-42040	Nut, 1/4-20", Keep, SS
46	4	HS-41041	Screw, 8-32 x 3/8", Phil, Pan, Zn
47	1	HN-42023	Nut, 10-24", Keps, Zn
49	1	SW-33007	Arm, Slack switch actuator
50	2	HX-43147	Spacer, 4 x 1/2"
51	2	HS-41123	Screw, 4-40 x 1-1/4", Slot, Pan, Zn
52	3	HN-42021	Nut, 4-40, Conical w/Kep Washer, Zn
54	2	HW-53018	Washer, 5/16", Split, SS, BO
55	4	HW-53017	Washer, Flat 5/16", SS, BO
56	1	FS-50125	Drip Shield
57	2	CW-50026	Wheel, Front
58	1	EH-42703	Clamp, Ribbon Cable
59	4	HS-41126	Screw, 5/16 x 1", BHSC, SS, BO
60	1	AW-18616-Q	Display Cable, Ribbon, Base
61	1	PL-36016B	Collar, Upright, Black
69	2	HX-51171	Clamp, Crank, Pivot
70	1	HX-50032	Gasket, Upright Collar
71	1	FM-51461	Shaft, Crank Pivot
72	1	FM-51462	Shaft, Parallel Arm
73	2	HS-41043	Screw, Pedal, 3/8"
74	2	HN-42043	Nut, 3/8-16" Flanged, SS, BO
75	2	SK-19101	Kit, Shaft, Pedal
76	1	AW-14142	Cable, Motor
77	1	BD-45028	Friction Belt

Cybox 530S Owner's Manual

ITEM NO.	QTY.	PART NO.	DESCRIPTION
78	1	FW-54008	Flywheel, Machined
79	3	HW-43003	Washer
80	1	AF-55010	Weldment, Frame
81	2	FM-51215	Spacer, Bottom Roller Side
88	1	FS-43143	Spacer, Clutch
89	1	HX-46026	Sprocket, 42 Tooth
90	1	FM-I-51459	Shaft, Clutch, Stepper
91	2	AX-61355	Clutch Pulley
92	1	AX-61365	Crank Arm, Left
93	1	AX-61366	Crank Arm, Right
95	1	HX-51050	Clamp, Flywheel
100	1	AC-19056-4	Assy, Display Console Complete, ENGLISH
B3	2	HX-19015	Grip, Upper
B4	2	HX-19014	Grip, Lower
B5	4	HX-40066	Plug, 1-1/2" Dia., Flat, 16 Ga
B50	1	SCK-19177	Assy, TV Support, ENGLISH
B51	1	AF-18552	Bracket, Adaptor, TV Mount
B52	4	HN-11879	Keeps, 8-32", Hex, Stl, Zinc
B53	4	HS-11347	Screw, 1/4 - 20 x 0.75", Schd, Btn, Blk
B60	1	AF-20681	Bracket, Mount,TV Arm
B61	1	AW-20421	Cable, 530S, A/V, I/O
B62	1	AW-20111	Cable, E5, RJ45
B63	1	CP-19879	Monitor, CYBEX, 15", NTSC/PAL
B63	1	CP-20665	Monitor, CYBEX, 15", SECAM/PAL
B64	1	CP-20215	Remote Control, CYBEX PEM
B65	1	EH-00986	Wire Tie
B66	4	HS-20731	Screw, M4 x 10, ScHd, Stl, Black
B67	4	HW-20212	Washer, Lock, M4, Zn
B68	4	HW-20214	Washer, Flat, M4
B69	1	HX-20221	Wrench, Allen, Round Tip, 3mm
B70	1	TR-20203	Power Supply, 12 VDC, 12-240 VAC, 6.0 A
B71	4	HW-00180	Washer, 1/4", Lock, Split
B72	4	HS-11347	Bolt, 1/4 -20.75", ScHd Btn, Black
B73	1	AW-14007	Power Cord, 115 VAC, 60Hz, USA,
B73	1	AW-20192	Power Cord, 100 VAC, 50HZ, 2.5M, IEC-320, JAPANESE
B73	1	AW-20193	Power Cord, 250 VAC, 3A, 2.5M, IEC-320, UK
B73	1	WR-14012	Power Cord, Euro, 220 VAC/50Hz
B101	2	AX-17578	Assy, C-HR Grips, Pair
B102	2	AX-19050	Assy, Handrail Left and right
B104	5	HX-17788	Tape,Double Sided, .032" Thick
B105	3	HX-18974	Seal, C-HR Grips
B200	1	AF-19057	Weldment, Upright Tube
B201	1	SCK-18796	Weldment, Console and Handle
B401	1	HX-19167	Cup Holder, 6.0 mm, Alloy Cage
B402	8	HW-00180	Washer, Lock Ext., 1/4", Zinc
B403	4	HS-18127	Bolt, 1/4-20 X 1.25", BHCS, SS, BLK
B404	2	PL-54001	Insulator, Handle
B405	8	HW-54000	Washer, Shoulder, Tube, 5/16", Plastic
B406	8	HS-11350	Screw, 5/16 - 18 X 7/8", Lg, HX, Soc, Btn
B408	8	HW-00165	Washer, Lock, Ext., 5/16", Zinc
B409	8	HS-17544	Bolt, 5/16 - 18 X .75", HXHD
B412	1	EH-00472	Wire Tie
C1	1	SW-18804-4	Membrane, 530S, TOP, ENGLISH
C2	1	SW-18805-4	Membrane, 530S, Bottom, With A/V, ENGLISH
C2	1	SW-18806-4	Membrane, 530S, Bottom, Without A/V, ENGLISH
C3	1	PL-18078	Console, Rear Plastic
C4	1	AF-18076	Plate, PCA Display Mounting
C5	1	PL-18077	Console, Front Plastic
C6	4	HS-15706	Screw, 8/16 X .50", PNHD, STL, BLK ZN
C7	6	HS-41187	Screw, 8-16 X 5-16", Plastite
C8	2	PL-17686	Tab, Book, Holder
C9	1	AX-19169-4	Assy, Console Door Cover, ENGLISH
C10	1	HS-16939	Sems, 10-32 X .75", Pnhd, Ext., Black, Zn
C11	4	HS-18311	Screw, 8-16 X .75", PNHD PHIL, STL
C12	1	EC-19236	Sensor, Wireless Heart Rate Receiver
C13	1	AW-18256	Cable, Embedded Polar, Jumper
C15	1	HX-17711	Plug, Hole, Plastic, 7/16", Black

Cybex 530S Owner's Manual

ITEM NO.	QTY.	PART NO.	DESCRIPTION
C16	1	AD-19138-Q	PCA, Display Board
C20	1	HW-10856	Washer, Lock, Ext., No.10, ZN
NS	0	AW-14004	Cord, Line, Jump, 1.4 M
NS	1	AW-14007	Power Cord, USA, 115 VAC/60Hz
NS	1	AW-18515	Display Cable, Upright
NS	1	AW-19221-Q	Cable, Cardio Touch
NS	2	AW-45030	Cable, Return
NS	1	AW-61007	Cable, RPM Sensor
NS	1	AX-19202	Assy Kit, Hardware Pack
NS	1	AX-45027	Chain, 39.5"
NS	1	AX-61361	RPM Sensor Assy
NS	1	AX-61374	Clutch Shaft and Sprocket Assy
NS	1	AX-62011B	Kit, Upright Collar, Black
NS	0	AX-71115	Bushing Kit
NS	1	DE-18959	Label, Switchplate, 530S
NS	1	DE-51609	RPM Disc
NS	1	DE-51755	Label, Cover, Left, 530S
NS	1	DE-51756	Label, Cover, Right, 530S
NS	1	EF-33017	Fuse, 1/4 Amp, Universal Power Board
NS	2	FM-44034	Spacer, 1-1/2 x 1/2", Nylon
NS	2	FM-51093	Shaft, 3/8 x 5.5", Spring Pulley
NS	1	FS-51055	Angle Bracket
NS	1	FS-51458	Bracket, Motor
NS	1	HB-44035	Bearing, 1/4" ID
NS	4	HN-42020	Pushnut, 3/8" Dia.
NS	2	HN-42037	Nut, 5/16-18", Jam, SS
NS	1	HS-41005	Screw, Shoulder Bolt 1/4 x 1-1/4", Alloy
NS	1	HS-41014	Screw, 4-40 X 5/16", Filster, Zn
NS	2	HS-41024	Screw, Set, 10-32 x 3/8" Nylon Patch
NS	8	HS-41076	Screw, 5/16 - 18 x 3/4", HHCS, G5, Zn
NS	2	HW-43039	Washer, Shoulder, 1/4" Nylon
NS	2	HW-43041	Washer, 10.4 mm X 5 mm, Nylon
NS	2	HX-05041	Bumper, Frame to Crank Arm, 5/16 - 18"
NS	2	HX-40027	Spring, Pedal Return
NS	1	HX-40028	Spring
NS	4	HX-43123	Spacer, 3/8" ID x 1/2" OD x 1", Large Nylon
NS	0	HX-71028	Return Spring Pulley Kit
NS	1	LT-18938-4	Manual, Owners, 530S, ENGLISH
NS	1	PL-50111	Bezel Switch, 530S
NS	4	PW-05036	Spring Pulley
NS	1	SK-16423	Motor 12vdc Service Kit w/Instructions
NS	1	SK-16763	Clutch Pulley, Shaft and Sprocket Assembly
NS	1	SK-17520	Slack Switch Kit
NS	1	SW-24005	Opto Switch Slotted
NS	1	WR-14012	Power Cord, Euro, 220 VAC/50Hz
NS	1	AW-14141	Cable, Power Switch
NS	1	SW-33014	Switch, DPST Rocker
NS	1	EH-34404	Outlet Module, IEC320
NS	1	AW-14048	Cable, Ground
NS	1	EH-34405	Inlet Module, IEC320
NS	1	AW-14098	Cable, Quick Connect
NS A/V	1	AW-17694	Cable and Audio Jack, 1/4" to 3.5 mm
NS A/V	1	CN-17687	Connector, Adapter, 1/4" Plug to 1/8" Jack
NS A/V	1	CN-20449	Adapter, Right Angle, 2.1 mm, Male, DC
NS A/V	1	DE-20198-4	Decal, Warning, A/V, ENGLISH
NS A/V	1	FS-17698	Clamp, Headphone Adapter
NS A/V	1	FS-18082	Bracket, Headphone Jack Mount
NS A/V	1	HA-20175	Headphone, 3.5mm
NS A/V	1	PL-20746	Cover, Rear Monitor, Access

NOTE: NS = Not Shown
NS A/V = Not Shown Audio Visual

530S Stepper

