

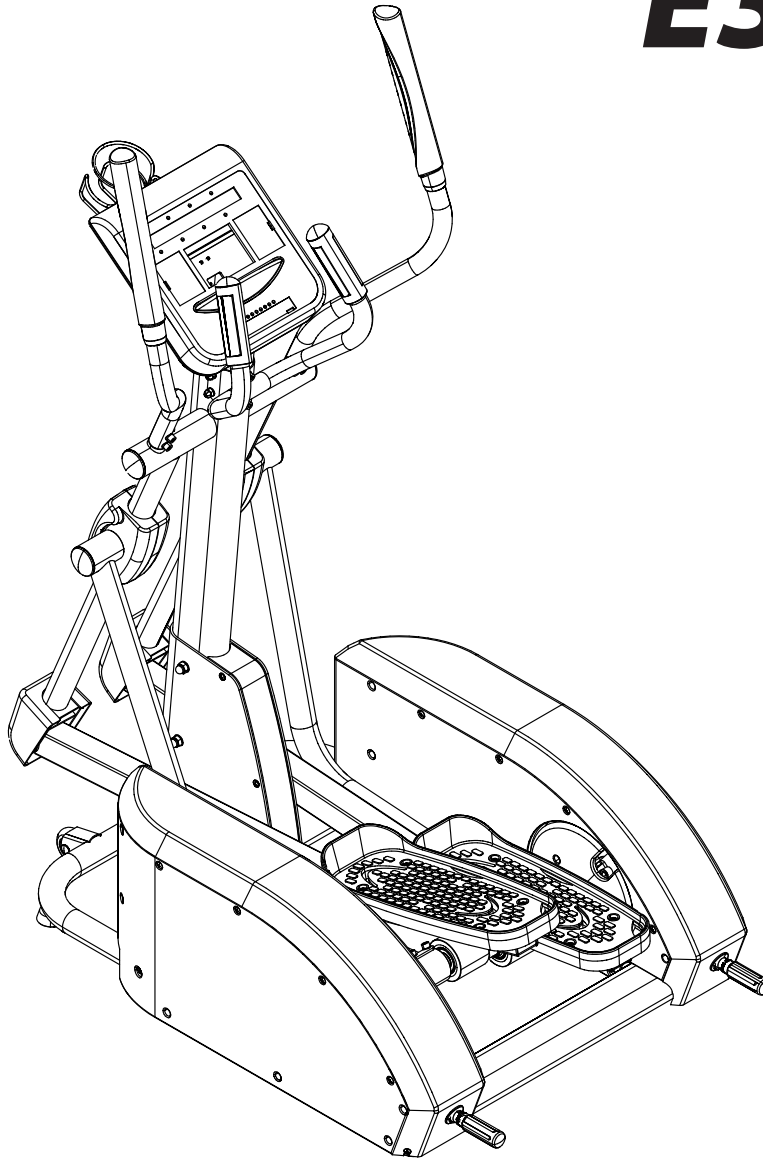

E300



Endurance® E300 Elliptical

User Manual

Table of Contents

Table of Contents.....	2
Introduction.....	3
Important Safety Information.....	4
Before You Begin.....	5
Assembly.....	6 - 25
Console Overview.....	26 - 27
Console Operation.....	28 - 34
Monitoring Your Heart Rate.....	35
Stretching & Flexibility.....	36
Warm-Up/Cool Down Exercises.....	37 - 43
Maintenance.....	44
Troubleshooting Guide.....	45
Parts List.....	46 - 49
Hardware.....	50 - 51
Exploded View.....	52
Notes.....	53

Endurance® continually seeks ways to improve the performance, specifications and product manuals in order to ensure that only superior products are released from our factories. Please take the time to carefully read through this manual thoroughly. Instructions contained in this document are not intended to cover all details or variations possible with Endurance® equipment, or to cover every contingency that may be met in conjunction with installation, operation, maintenance or troubleshooting of the equipment. Even though we have prepared this manual with extreme care, neither the publisher nor the author can accept responsibility for any errors in, or omission from, the information given. Should additional information be required, or should situations arise that are not covered by this manual, the matter should be directed to your local Endurance® representative, or the Service Department at Endurance® in Forest Park, Illinois.

© Copyright 2009. Endurance®. All rights reserved. Endurance® reserves the right to change design and specifications when we feel it will improve the product. Endurance® machines maintain several patented and patent pending features and designs. All rights reserved on all design patents and utility patents.

Congratulations!!

Thank you for purchasing your new Endurance® Elliptical.

With state-of-the-art technique, robust frame structure and superior ergonomic design, Endurance® Ellipticals set a new standard for excellence. Endurance® Ellipticals can improve your quality of life by keeping you fit and healthy, increasing your energy levels and enhancing your lifestyle.

Endurance® wants to ensure years of quality workouts with your new Elliptical so we recommend that you read this manual carefully and thoroughly to fully understand proper use and maintenance of this product. Retain this Owner's Manual for future reference.

Please use this Owner's Manual to make sure that all parts have been included in your shipment. When ordering parts, you must use the part number and description from this Owner's Manual. Use only Endurance® replacement parts when servicing this machine. Failure to do so will void your warranty and could result in personal injury.

For information about product operation or service, check out the official Endurance® website at www.bodysolid.com/Home/Endurance-Cardio or contact an authorized Endurance® dealer or an Endurance® factory-authorized service company or contact Endurance® Customer Tech Support at one of the following:

Toll Free: 1-800-556-3113
Phone: 1-708-427-3555
Fax: 1-708-427-3556
Hours: M-F 8:30-5:00 CST
E-Mail: service@bodysolid.com

Or write to:

Endurance® Service Department
1900 S. Des Plaines Ave.
Forest Park, IL 60130 USA

URANCE®

by *Body-Solid*

Important Safety Information

Save this Owner's Manual!

Before beginning any fitness program, you should obtain a complete physical examination from your physician.

When using exercise equipment, you must always take basic precautions, including the following:

- Read all instructions before using your Endurance® Elliptical. These instructions are written to ensure your safety and to protect the unit.
- DO NOT allow children on or near the equipment.
- Use the equipment only for its intended purpose as described in this guide.
- DO NOT use accessory attachments that are not recommended by the manufacturer. Such attachments might cause injuries and will void your warranty.
- Wear proper exercise clothing and shoes for your workout, no loose clothing.
- DO NOT use cleats, spikes or any other non-athletic shoes.
- DO NOT use this product while barefoot or wearing only socks.
- Use care when getting on or off the unit.
- DO NOT overexert yourself or work to exhaustion. If you experience any pain such as chest pains, nausea, dizziness, shortness of breath or abnormal symptoms, stop your workout immediately and consult your physician before continuing.
- Never operate the unit when it has been dropped or damaged. Return the equipment to a service center for examination and repair.
- Never drop or insert objects into any opening in the equipment.
- Always check the unit for loose components before each use.
- DO NOT turn pedals by hand.
- DO NOT use the equipment outdoors or near water. It is imperative that your Endurance® Elliptical is used in a climate controlled environment. If your elliptical has been exposed to colder temperatures or to high moisture climates, it is strongly recommended that the elliptical is brought to room temperature before use. Failure to use this equipment in a climate controlled environment may cause premature electronic failure.
- Unplug the elliptical before moving or cleaning it. DO NOT pull the power cord to move this product. Keep the power cord away from heated surfaces.
- Endurance® recommends that a mat is placed under the unit to protect the floor or carpet and for easier cleaning.

Endurance® Ellipticals are designed for your enjoyment. By following these precautions and using common sense, you can have many safe and pleasurable hours of healthful exercise with your Endurance® Elliptical.

Before You Begin

The Endurance® E300 is carefully tested and inspected before shipment. We have shipped the unit in several pieces that require assembly. Carefully unpack the unit in a clear area and lay the pieces on the floor near the area where you plan to use the equipment. Remove the packing material. Do not dispose of the packing material until assembly is complete and the unit is working properly. Place the unit on a clean level surface for assembly. Make sure there is easy access to an electrical outlet. Before assembling, the unit should be placed as close as possible to its final location. *Be careful to assemble all components in the sequence presented in this guide.*

PERSONAL SAFETY DURING ASSEMBLY

- It is strongly recommended that a qualified dealer assemble the equipment. *Assistance is required.*
- Before beginning assembly, please take the time to read the instructions thoroughly.
- Read each step in the assembly instructions and follow the steps in sequence. *Do not skip ahead.* If you skip ahead, you may learn later that you have to disassemble components and that you may have damaged the equipment which will void the warranty.
- Assemble and operate the Endurance® Elliptical on a solid, level surface. Locate the unit a few feet from the walls or furniture to provide easy access.

AFTER ASSEMBLY

Once the unit is assembled, you should check all functions to ensure correct operation. If you experience problems, first recheck the assembly instructions to locate any possible errors made during assembly. If you are unable to correct the problem, call the dealer from whom you purchased the machine or call Endurance® Customer Tech Support Hot Line Toll Free at: 1-800-556-3113.

URANCE®

by Body-Solid

Step 1

IMPORTANT:

DO NOT tighten hardware until instructed to do so.

- A. Slide Upright (F) slightly into Mainframe (A) as shown.
- B. Connect the harness from Upright (F) to the harness on Mainframe (A).
- C. Completely slide Upright (F) into Mainframe (A) and secure using:
Three 168 (M10x80 allen head bolt)
Nine 87 (M10 flat washer)
Three 96 (M10 crown nut)
Three 70 (M10x120 allen head bolt)

NOTE: Be careful not to pinch wires.

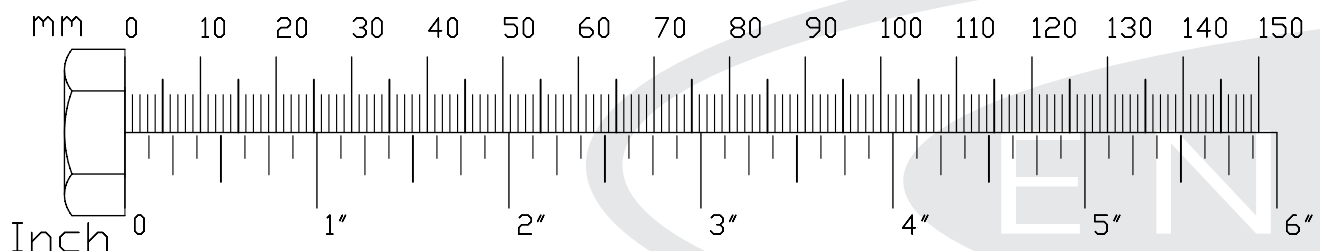

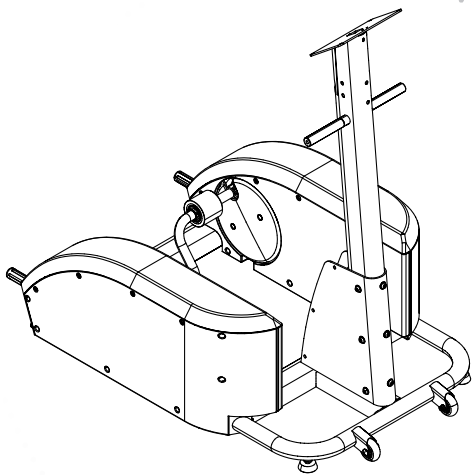

Above shows STEP 1 assembled and completed.

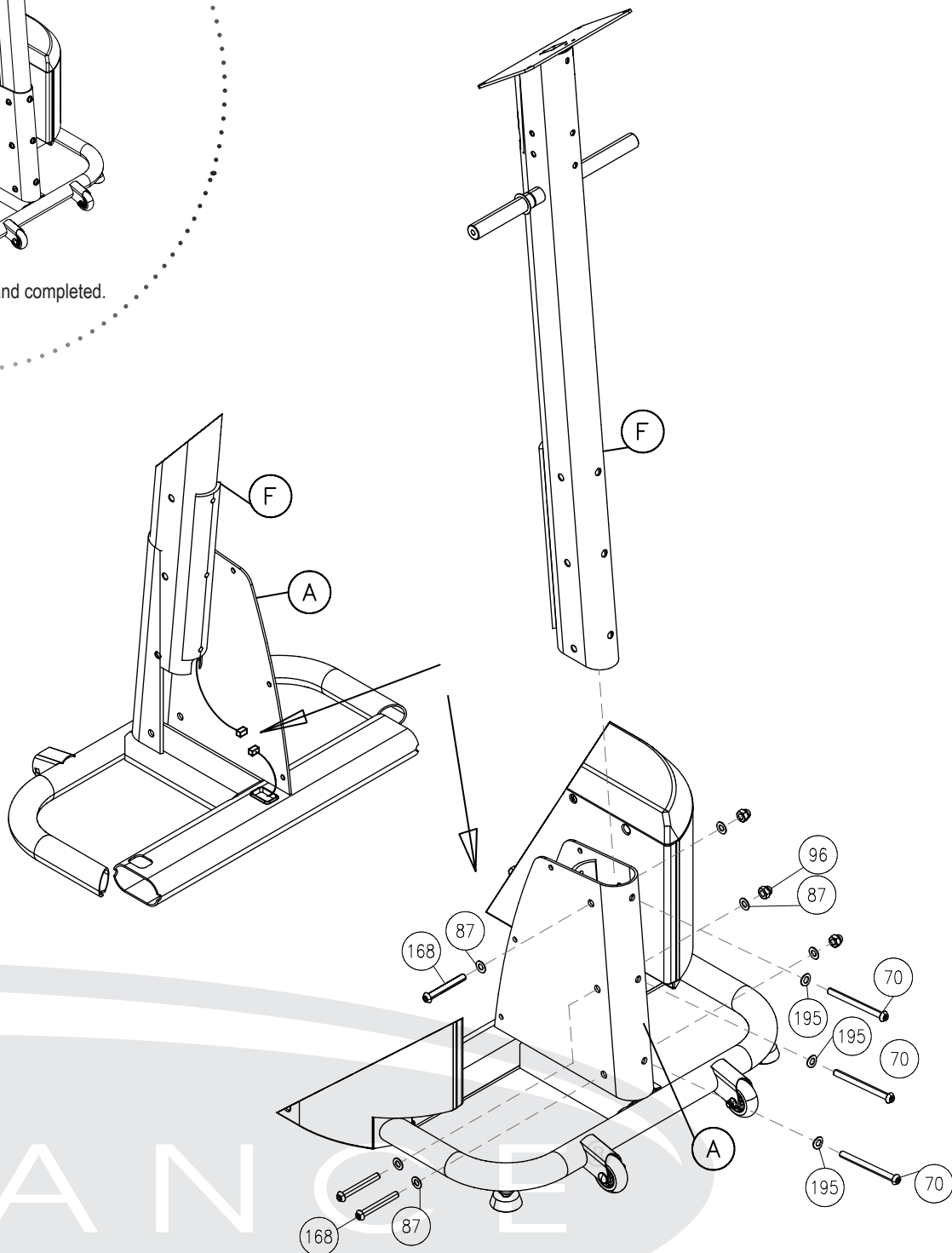

Step 2

- A. Insert Mainframe Cover (K) into Mainframe (A) and secure using:
Six 63 (M5x12 phillips pan head bolt)
Six 88 (M6 flat washer)

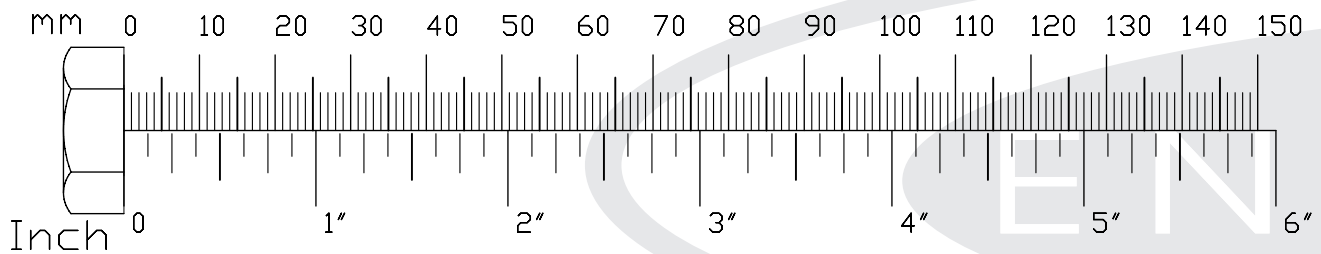

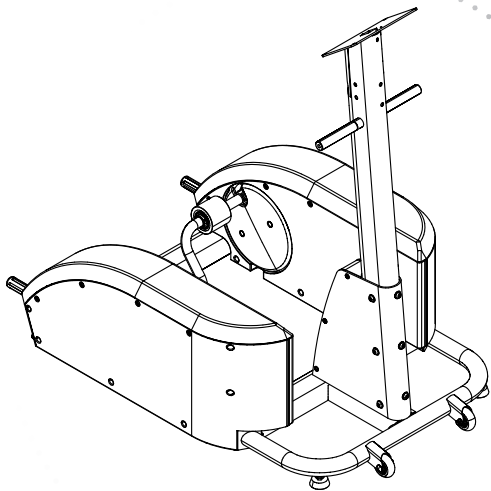

Above shows STEP 2 assembled and completed.

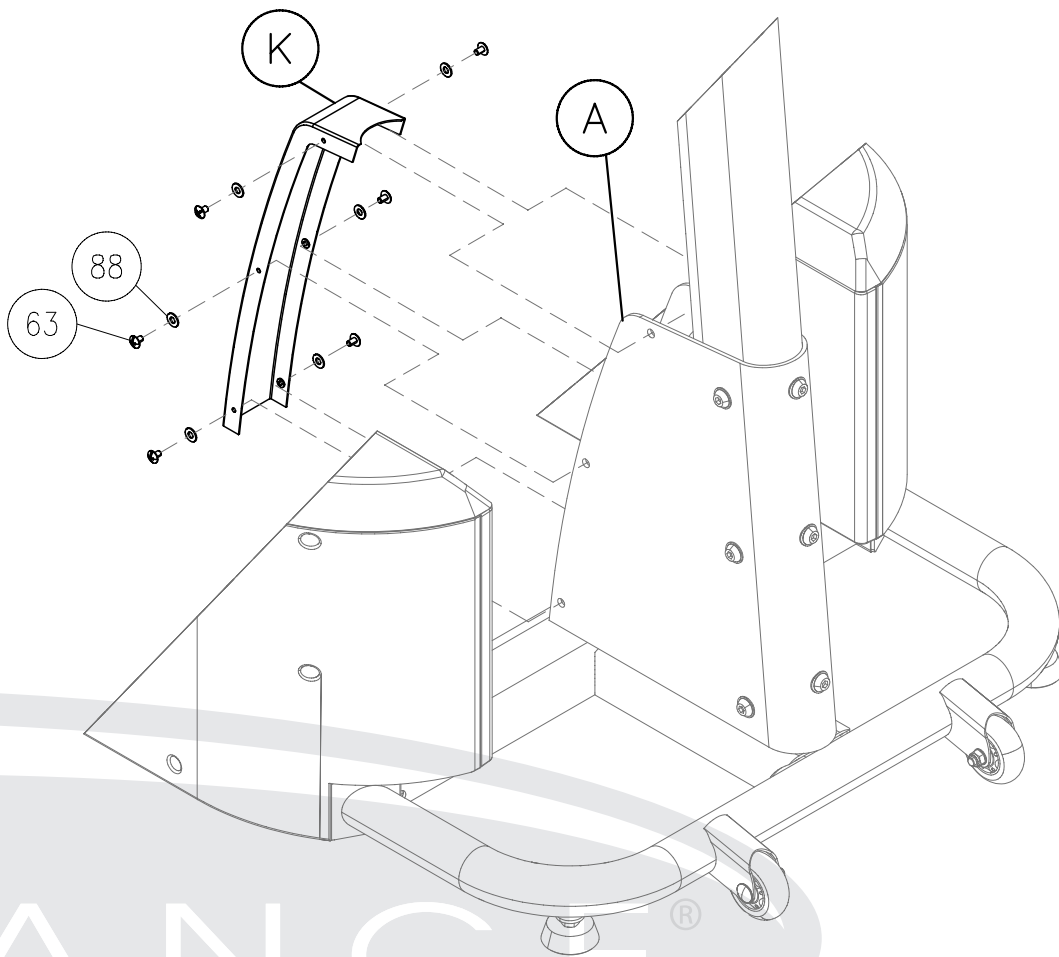

Step 3

- A. Insert Right Stride Frame (R) and Left Stride Frame (N) onto Upright (F).
- B. Secure Right Stride Frame (R) to Upright (F) using:
One 78 (M10x20 hex head bolt)
One 90 (M10 spring washer)
One 84 (M10 washer)
- C. Insert End Cap (122) into Right Stride Frame (R).
- D. Secure Left Stride Frame (N) to Upright (F) using:
One 78 (M10x20 hex head bolt)
One 90 (M10 spring washer)
One 84 (M10 washer)
- E. Insert End Cap (122) into Left Stride Frame (N).

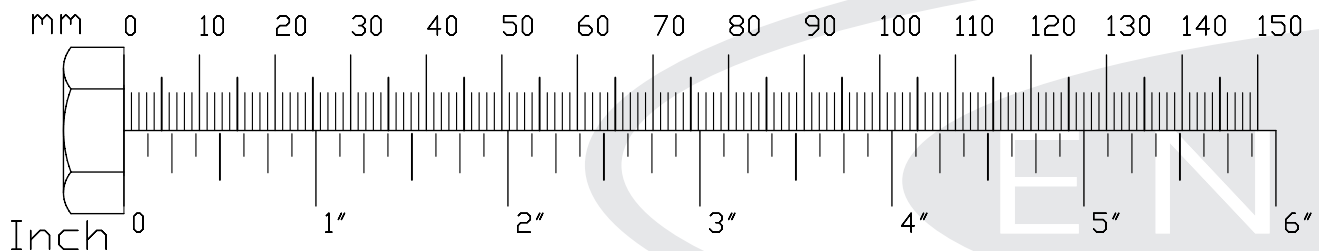

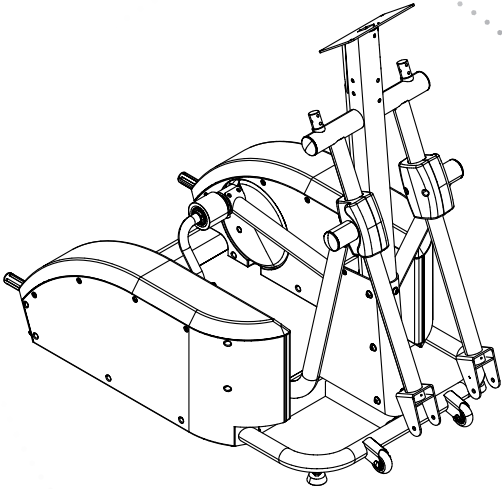

Above shows STEP 3 assembled and completed.

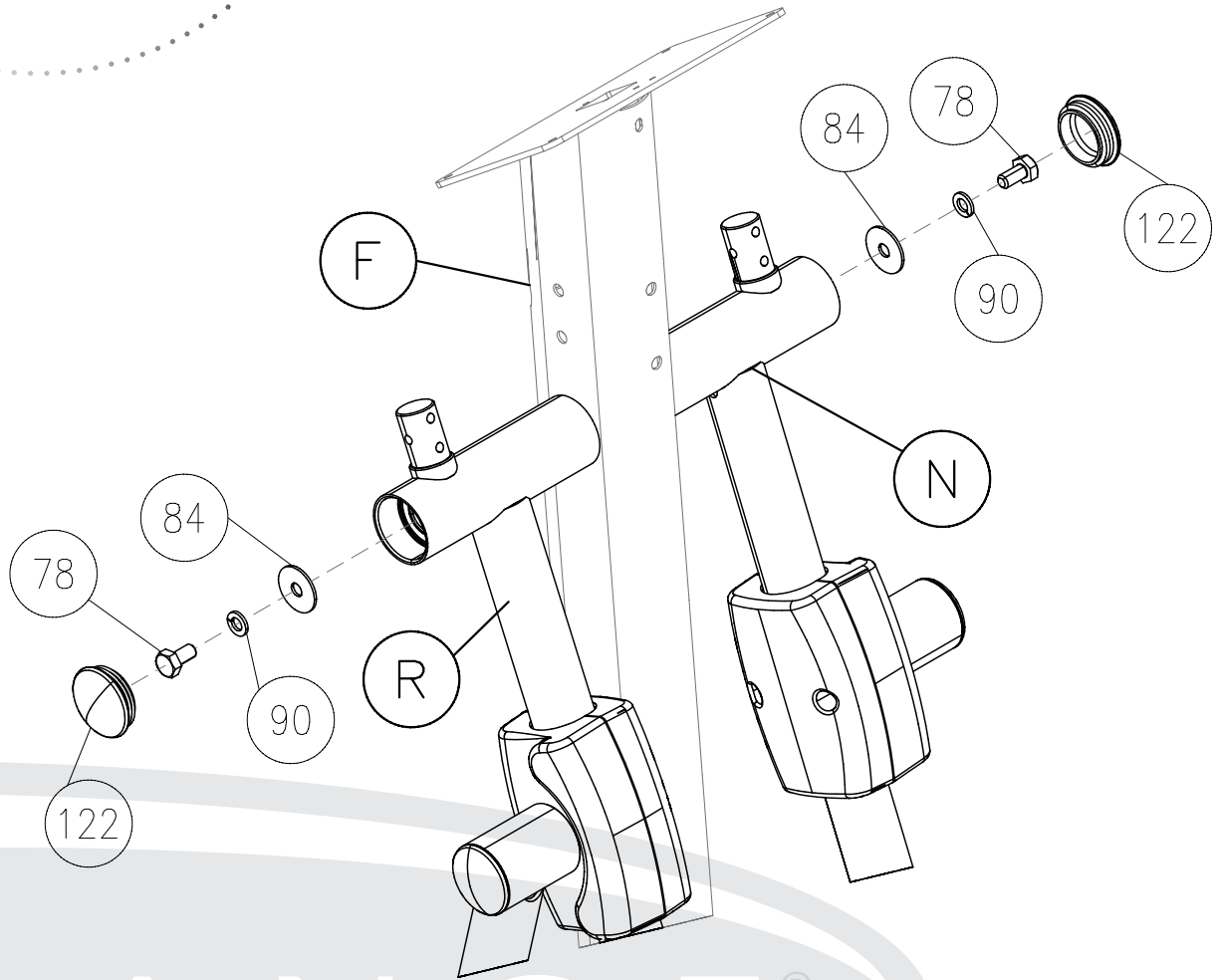

Step 4

- A. Lift and place Right Junction Frame (P) onto Shaft Sleeve (163) and secure using:
Four 54 (M8x12 allen head)
Four 86 (M10 flat washer)
- B. Lift and place Left Junction Frame (Q) onto Shaft Sleeve (163) and secure using:
Four 54 (M8x12 allen head)
Four 86 (M10 flat washer)

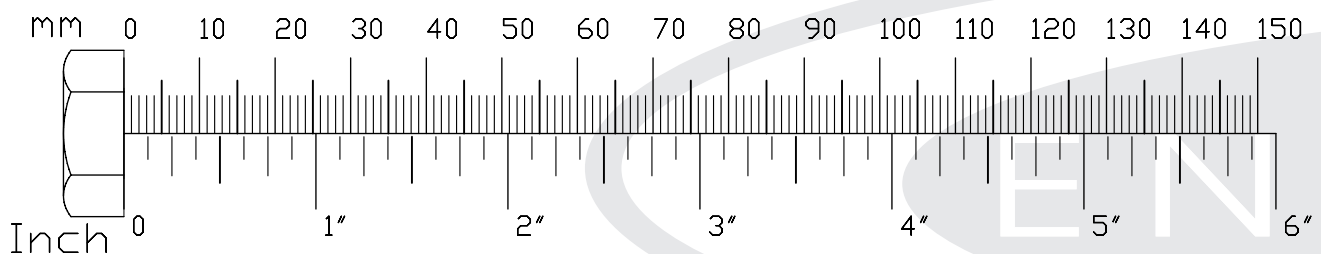

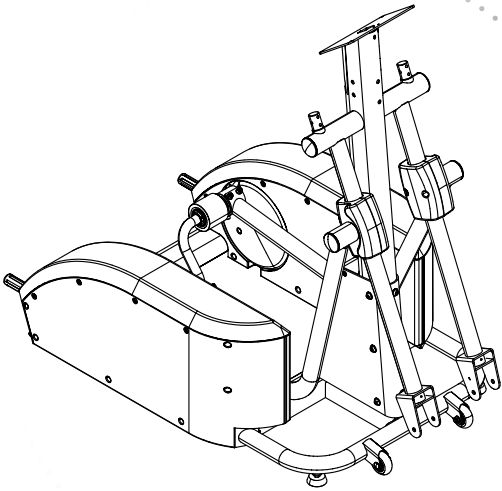

Above shows STEP 4 assembled and completed.

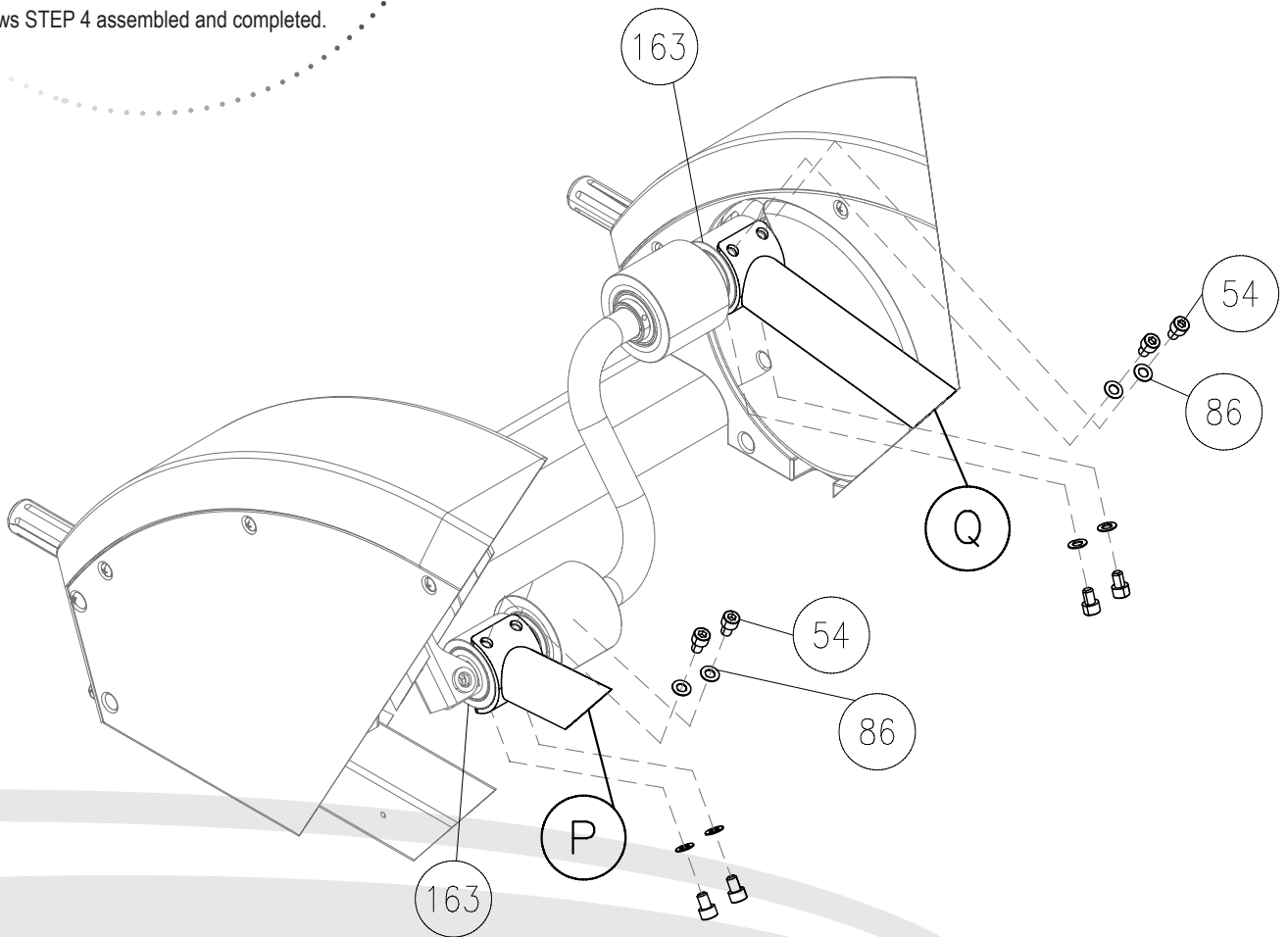

Step 5

- A. Connect Leg (L) to Right Stride Frame (R) using:
One 81 (M10x81.5 hex head bolt)
One 98 (M10 nut)

NOTE: It is recommended that two adults align and secure the Legs to the Stride Frame.

- B. Connect Leg (M) to Left Stride Frame (N) using:
One 81 (M10x81.5 hex head bolt)
One 98 (M10 nut)

NOTE: Please ensure that Pedal (25) is centered onto Shaft Sleeve (163) as shown in the diagram on the far right.

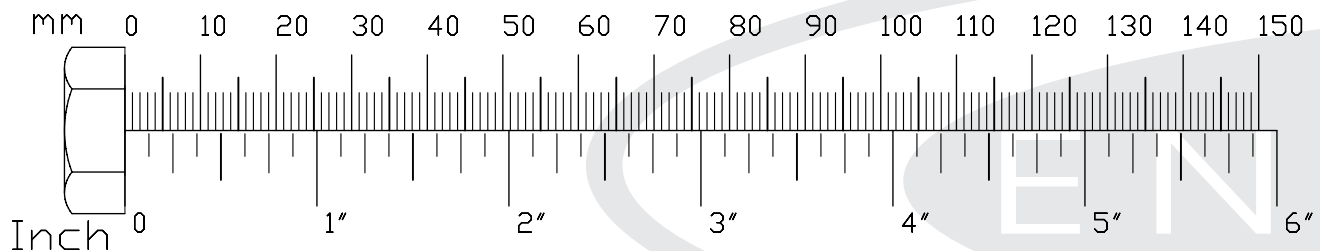

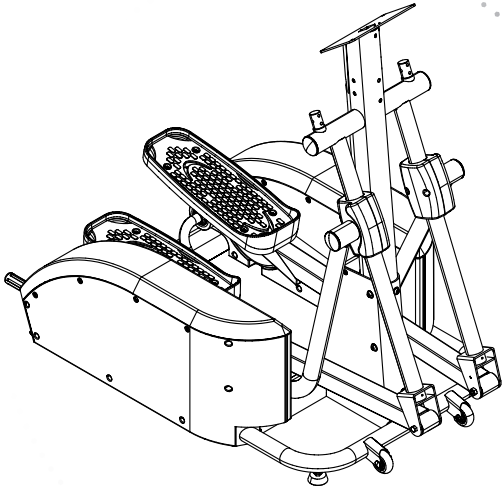

Above shows STEP 5 assembled and completed.

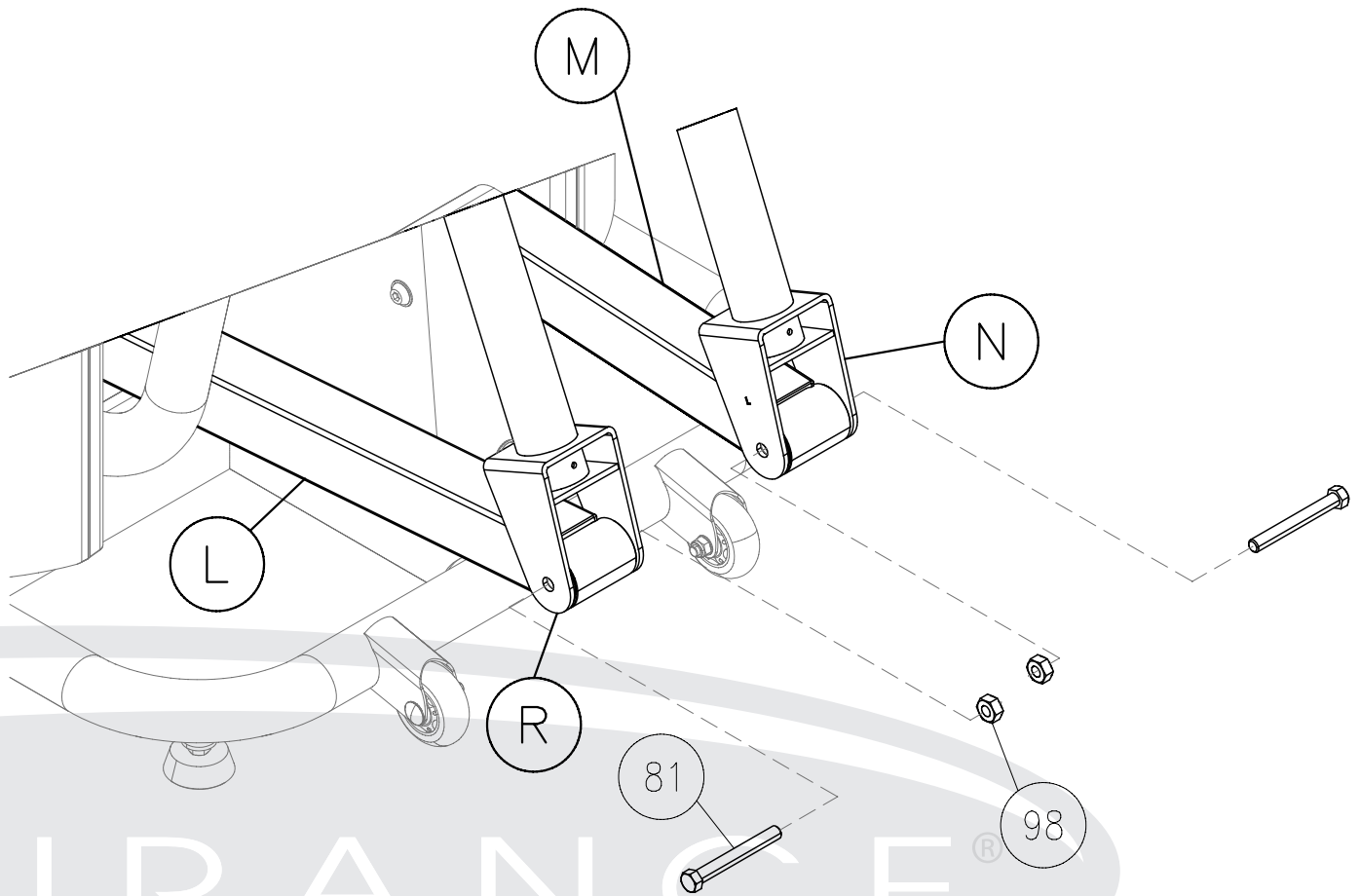
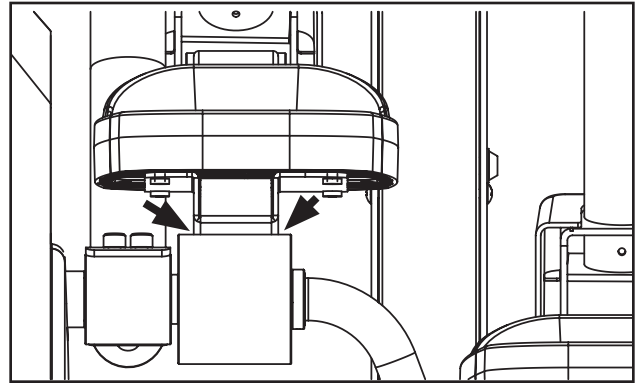

Step 6

- A. Connect Bracket Cover (30) to Right Stride Frame (R) using:
One 66 (M5x12 phillips head pan screw)

NOTE: Do not overtighten screw, this will damage Bracket Cover (30).

- B. Connect Bracket Cover (30) to Left Stride Frame (N) using:
One 66 (M5x12 phillips head pan screw)

NOTE: Do not overtighten screw, this will damage Bracket Cover (30).

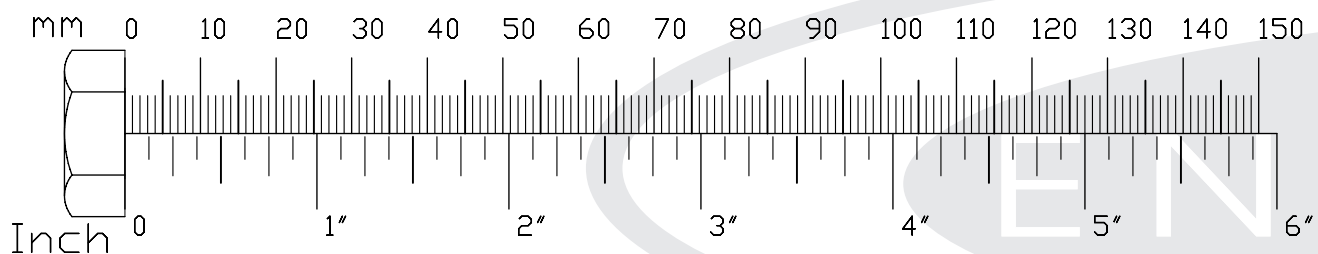

Step 6

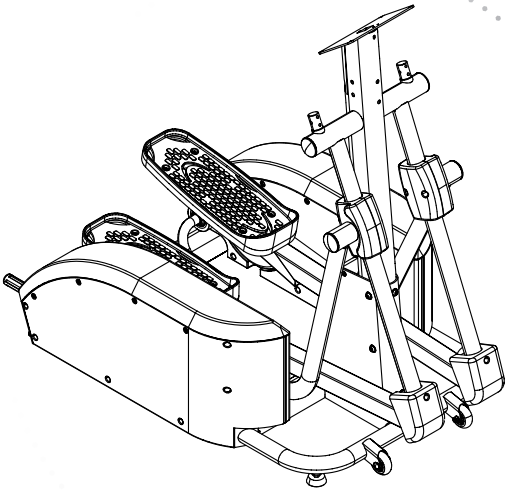

Above shows STEP 6 assembled and completed.

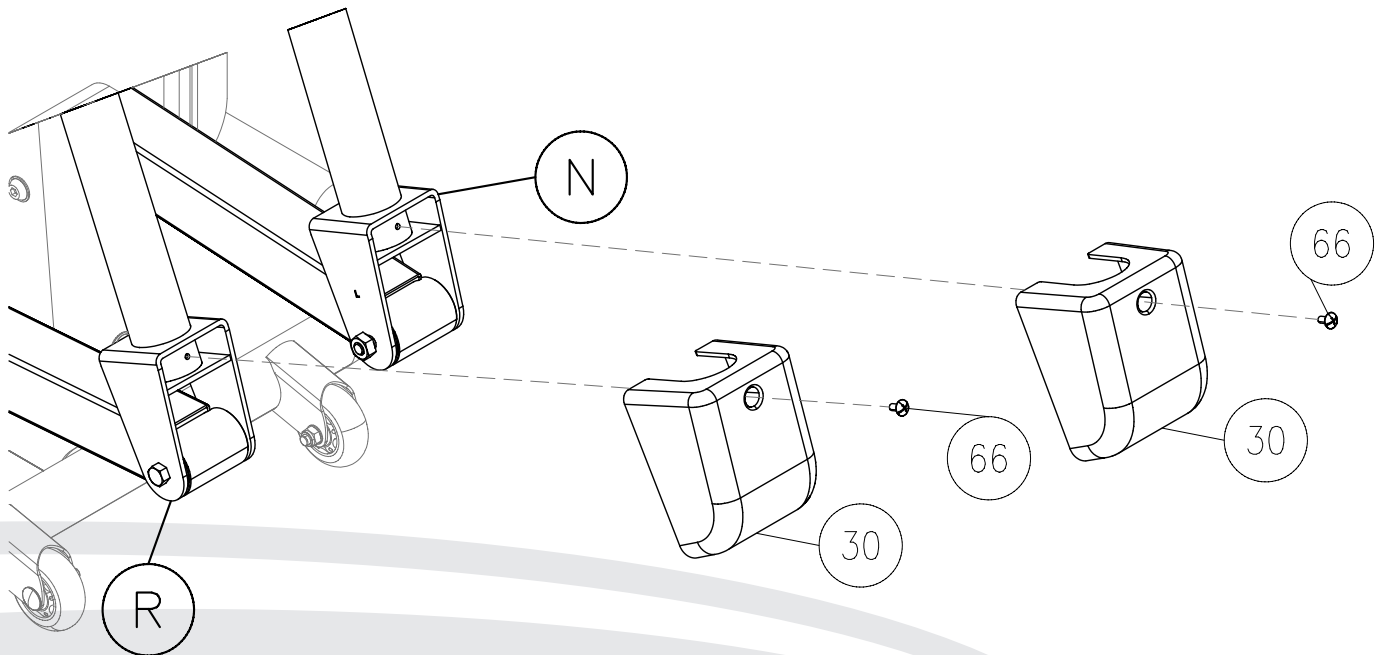

Step 7

- A. Insert Right Arm (G) into Right Stride Frame (R) and secure using:
Three 77 (M8x16 allen head bolt)
Three 86 (M8.4 flat washer)
- B. Insert Left Arm (I) into Left Stride Frame (N) and secure using:
Three 77 (M8x16 allen head bolt)
Three 86 (M8.4 flat washer)

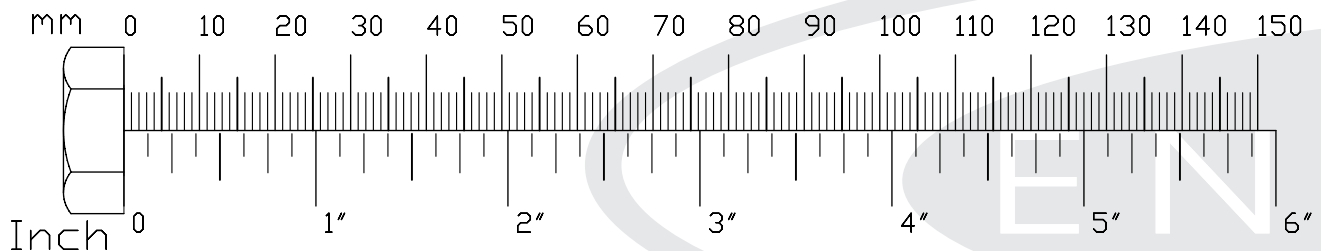

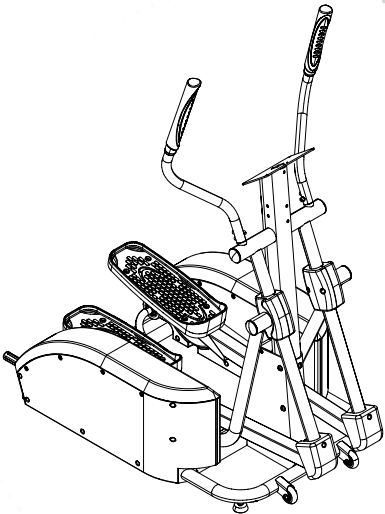

Above shows STEP 7 assembled and completed.

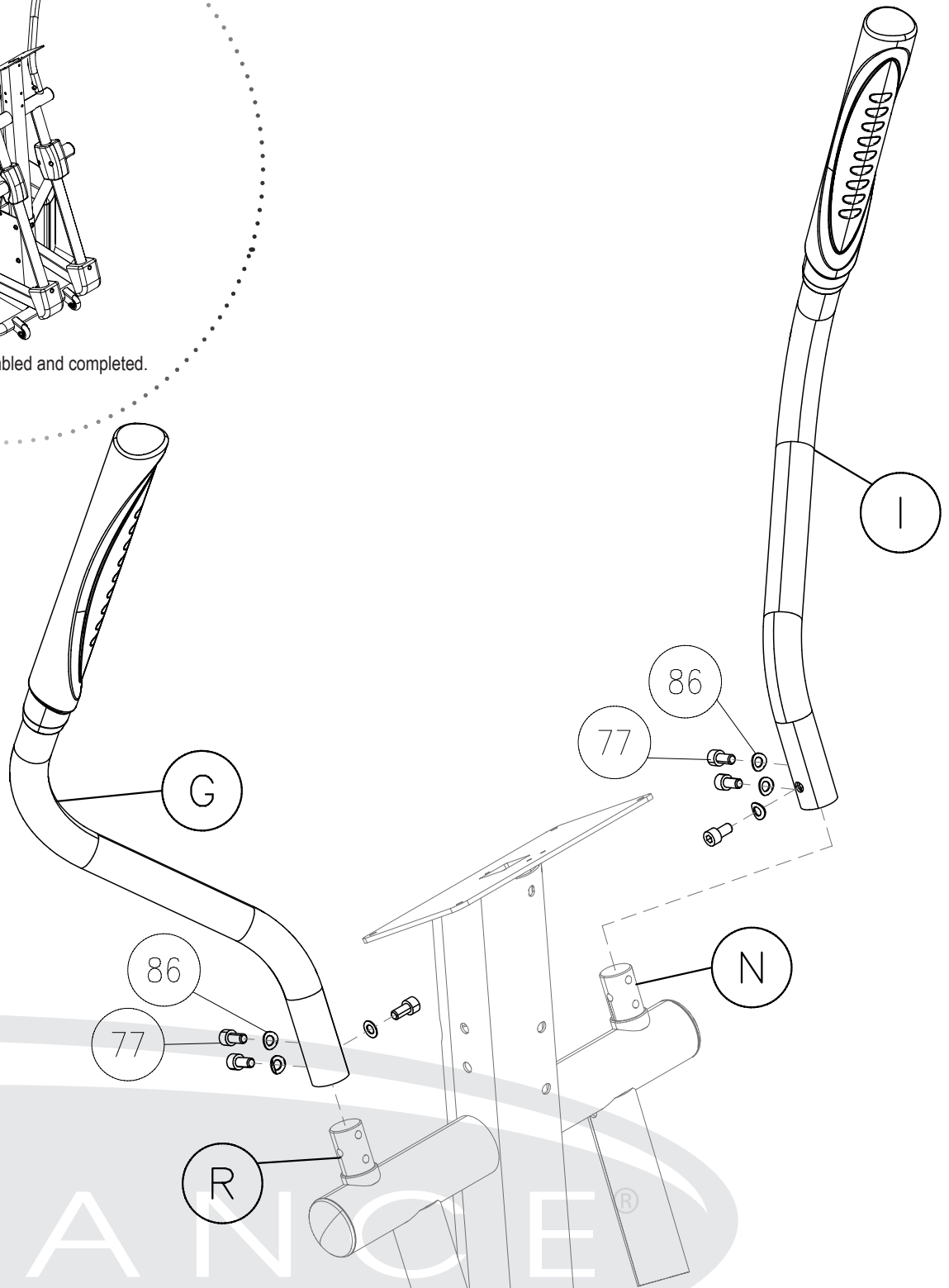

Step 8

- A. Connect Upper Console Wire and Heart Rate Wires to the back of Console (15).

NOTE: The single Heart Rate ground spade connector is connected to the left of the red console harness. Ensure that all wires are secure inside console. Be careful not to pinch wires.

- B. Secure Console (15) to Upright (F) using:
Four 63 (M5x12 phillips pan head bolt)

NOTE: The four Console Screws are located in the Step 8 hardware bag.

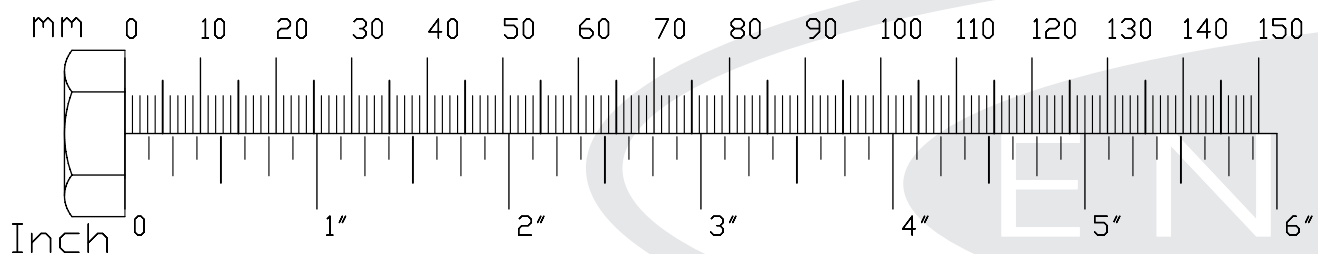

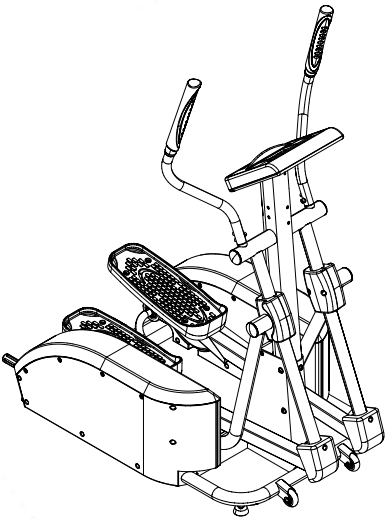

Above shows STEP 8 assembled and completed.

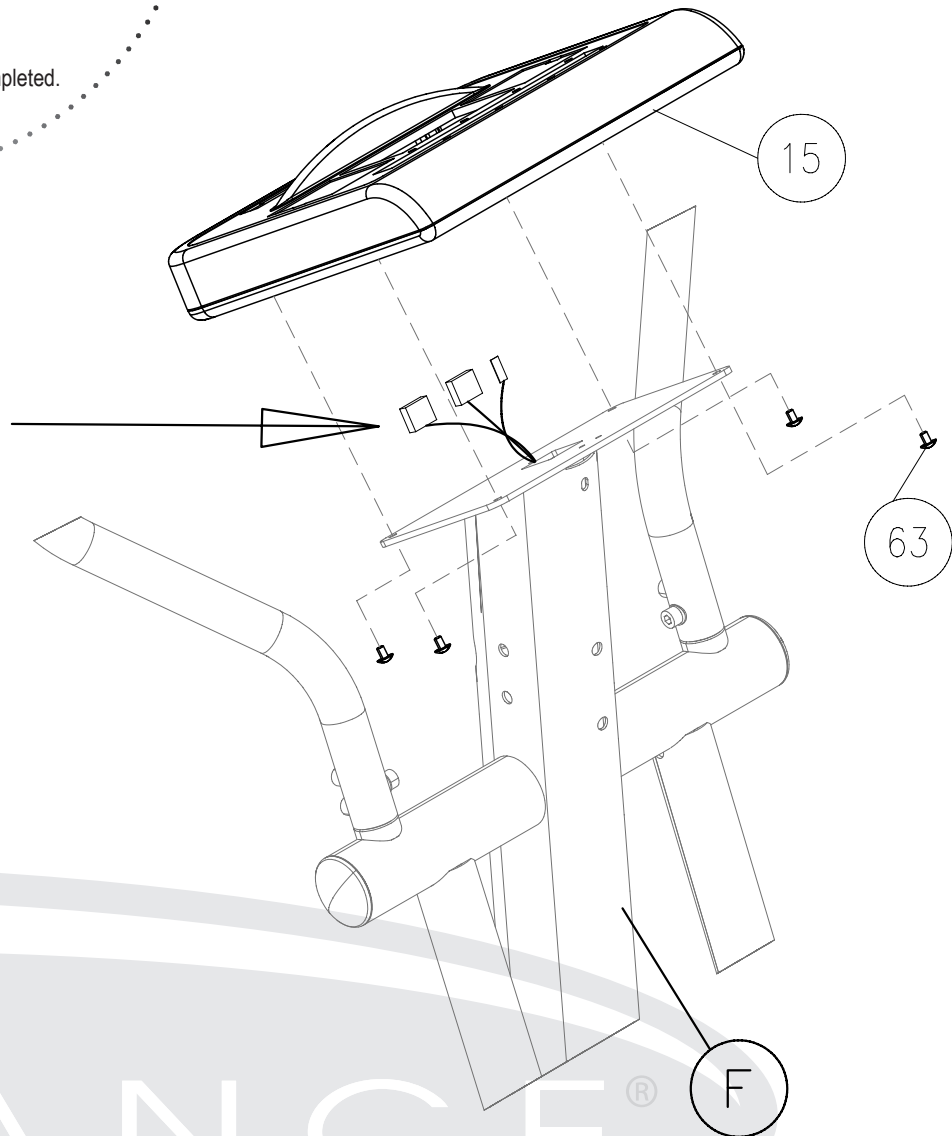

Step 9

- A. Connect the harness on Handle Bar (E) to the harness on Upright (F) as shown.
- B. Connect Handle Bar (E) to Upright (F) using:
Two 68 (M8x120 allen head bolt)
Eight 86 (M8.4 washer)
Four 95 (M8 crown nut)
Two 69 (M8x75 allen head bolt)

*NOTE: Ensure that all wires are secure inside Handle Bar (E) and Upright (F).
Be careful not to pinch wires.*

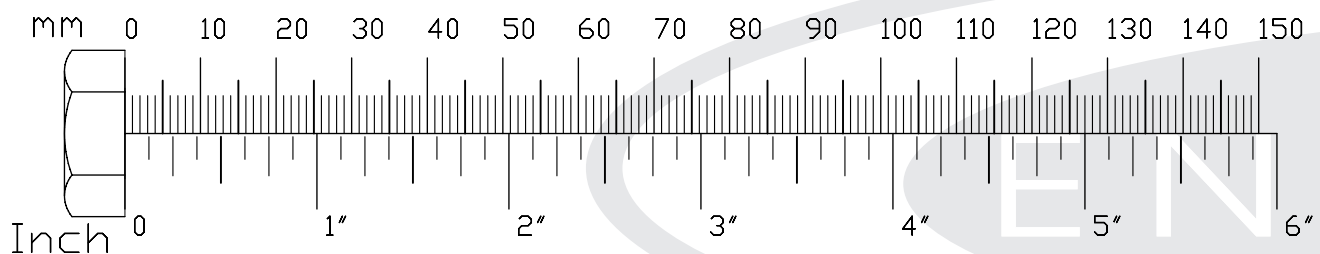

Step 9

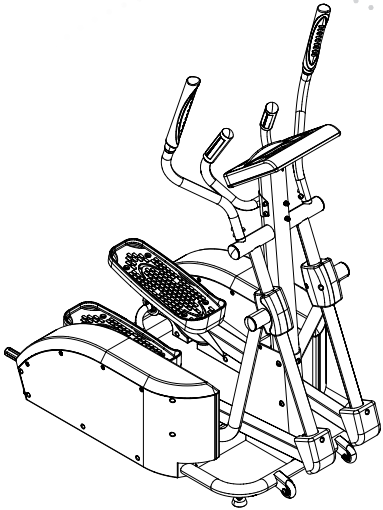

Above shows STEP 9 assembled and completed.

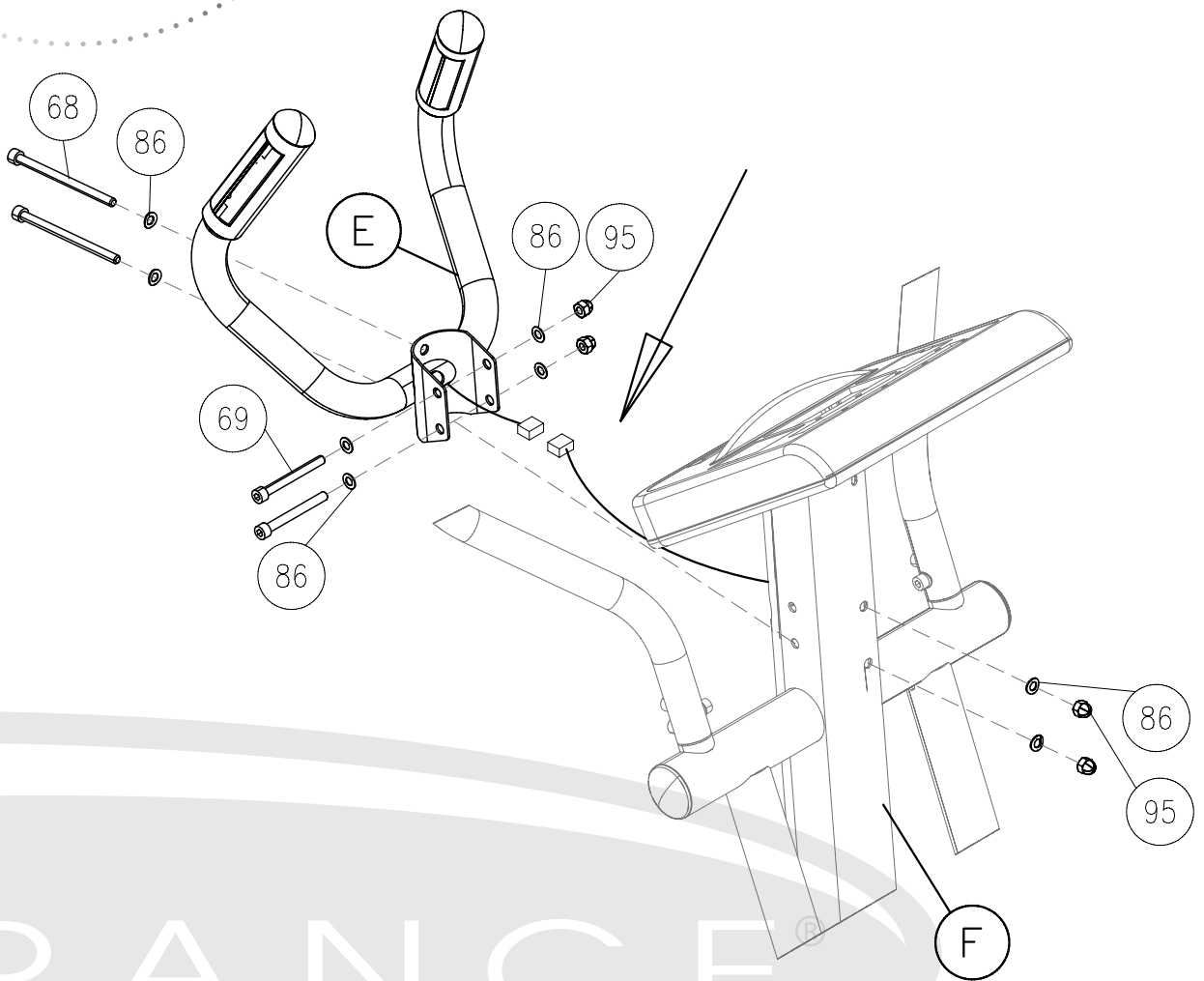

Step 10

- A. Connect Water Holder (119) to Upright (F) using:
Three 67 (M5x12 pan head bolt)
- B. Tighten all installed assembly hardware at this time.
- C. Congratulations!! The installation of your new Elliptical is complete.

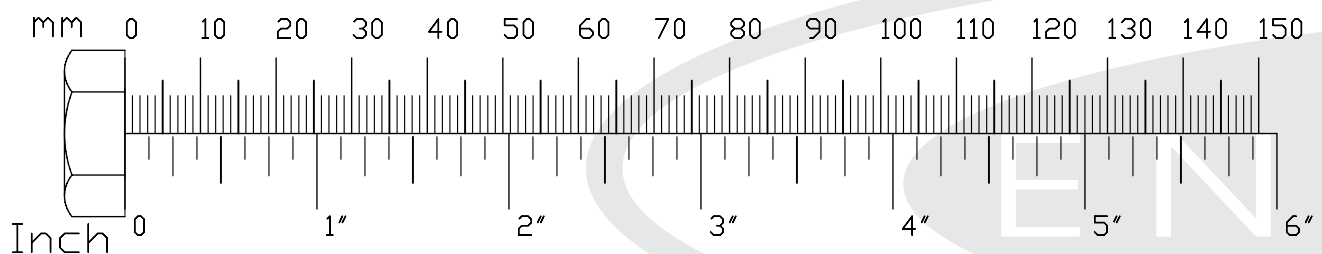

Step 10

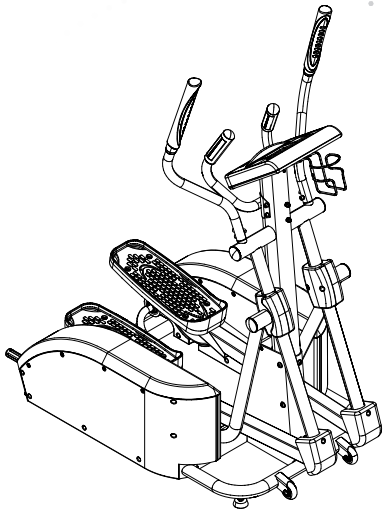

Above shows STEP 10 assembled and completed.

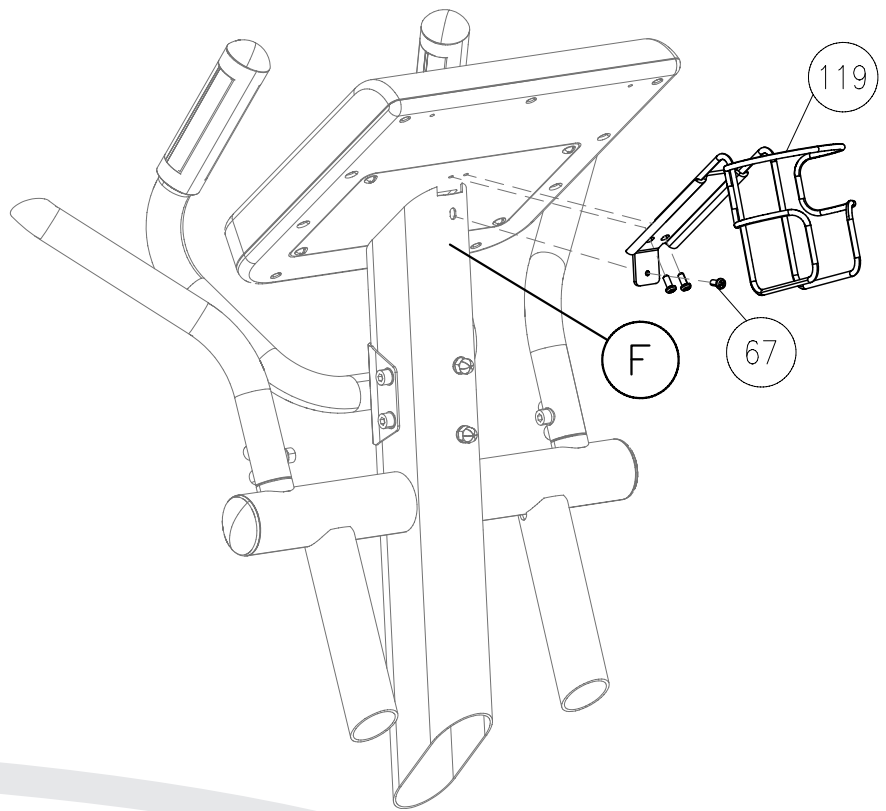

URANCE®

by *Body-Solid*

Console Overview

Take a few moments to review the console layout. Below is an overview of the console buttons and their different functions.

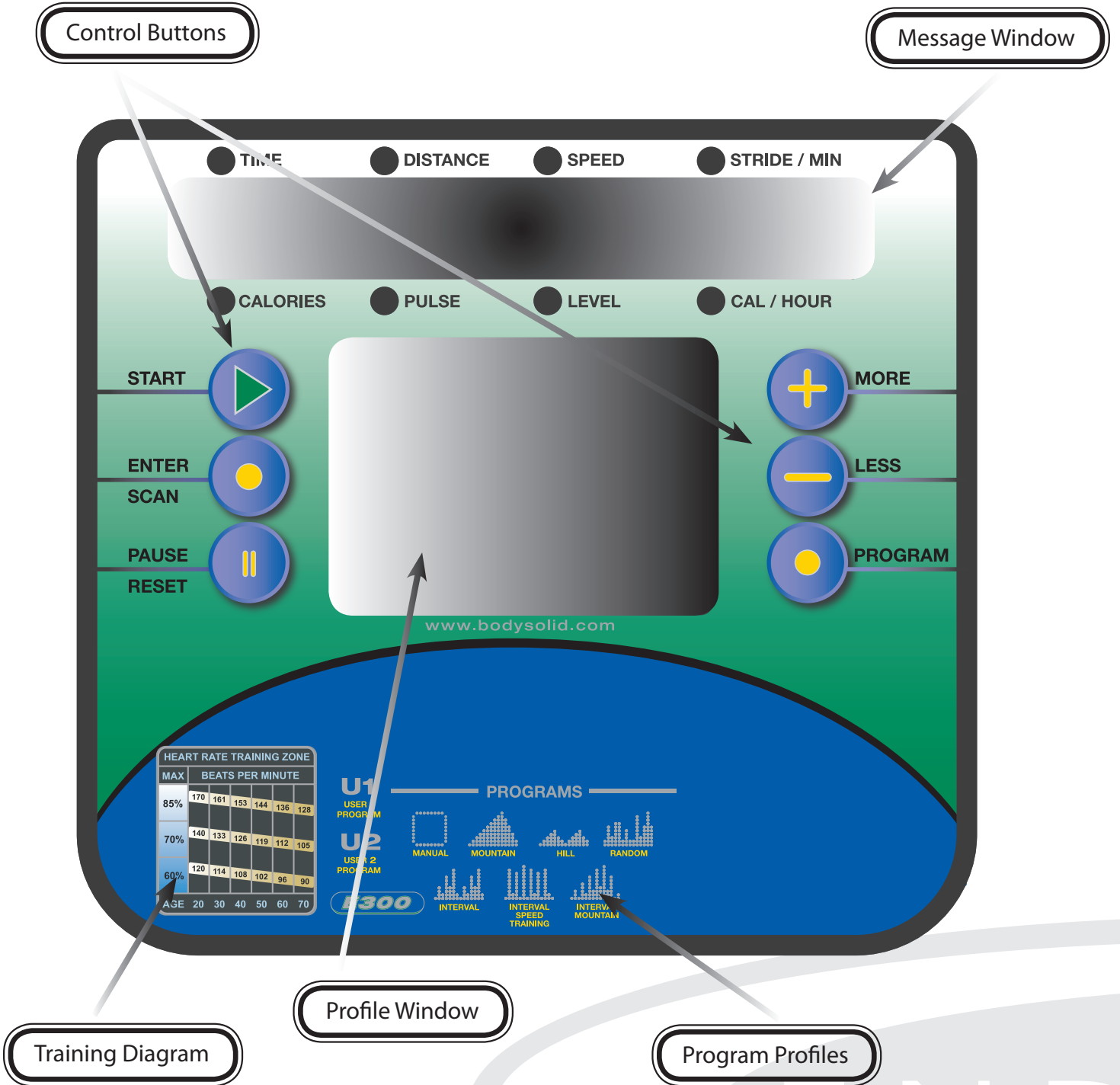

Console Overview





START

Press the **START**  button to enter the *Quick Start Mode*.

In *Pause Mode*, the **START**  button is used to resume the exercise session.

ENTER/SCAN

In Program Mode, the **ENTER/SCAN**  button is used to confirm the values you set.

During exercise, press the **ENTER/SCAN**  button once and the main console window is placed in *Auto Scan Mode*. The display will change every four seconds from TIME/DISTANCE/SPEED/STRIDES PER MINUTE to CALORIES/PULSE/LEVEL/CALORIES PER HOUR. To exit *Auto Scan Mode* and enter *Manual Scan Mode*, press and hold the **ENTER/SCAN**  button for two seconds. The console will beep twice to confirm that the selection was entered. *Manual Scan Mode* allows you to toggle the display from TIME/DISTANCE/SPEED/STRIDES PER MINUTE to CALORIES/PULSE/LEVEL/CALORIES PER HOUR by pushing the **ENTER/SCAN**  button when the change in display is desired. To return to the *Auto Scan Mode*, press and hold the **ENTER/SCAN**  button for two seconds. The console will beep twice to confirm that the selection was entered.

PAUSE/RESET

During exercise, the **PAUSE/RESET**  button is used to pause the workout.

In *Pause mode*, the **PAUSE/RESET**  button is used to reset the program time and workout data to zero.

In *Program mode*, the **PAUSE/RESET**  button is used to reset values to their default setting.

CAUTION: In User 1 and User 2 programs, the user profile data will be also cleared when pushing the **PAUSE/RESET**  button.

MORE/LESS

In *Program mode*, the **MORE** /**LESS**  buttons are used to increase/decrease TIME, WEIGHT and AGE.

During exercise, the **MORE** /**LESS**  buttons are used to increase/decrease the resistance level from 1 to 20. Press and hold the **MORE** /**LESS**  buttons for two seconds to rapidly increase/decrease values.

PROGRAM

In *Program Mode*, the **PROGRAM**  button is used to toggle between workout programs. The program selected is displayed in the **MESSAGE WINDOW**. The program profile is displayed in the **PROFILE WINDOW**.

Console Operation

There are two information windows on the console:

MESSAGE WINDOW

The MESSAGE WINDOW displays Program Names, Messages, TIME, DISTANCE, SPEED, STRIDE/MIN, CALORIES, PULSE, RESISTANCE LEVEL and CALORIE/HOUR.

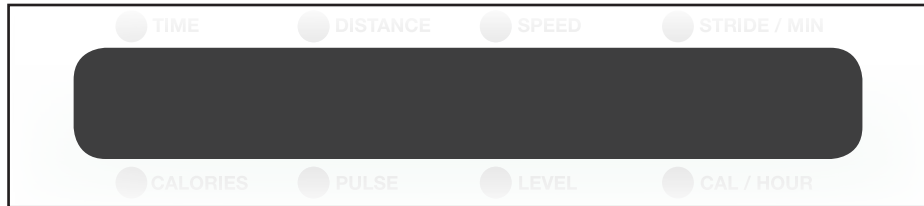

Console Message Window

PROFILE WINDOW

This 10 X 14 LED PROFILE WINDOW displays Program Profile, Tension (Resistance) Bar, Heart Rate Bar (HR Programs only), Lap Progress Display and Lap Counter. The PROFILE WINDOW toggles between program profile (displayed for 10 seconds in window) and lap counter (displayed for 30 seconds in window), except in Heart Rate Programs.

NOTE: When changing resistance levels in preset programs, the change will not show in the program profile. Changes in resistance will show in the first column when lap progress function is shown.



Console Profile Window

Console Operation

LAP DISPLAY

Lap Display shows your progress around a virtual track. Lap Display also shows the resistance level in the first column. Every dot in the resistance column represents an increment of two resistance levels. Resistance is adjustable from 1-20. One dot on the lap counter is equal to 15 revolutions and one revolution is equal to 2 steps. The track will blink showing the exerciser's current position.

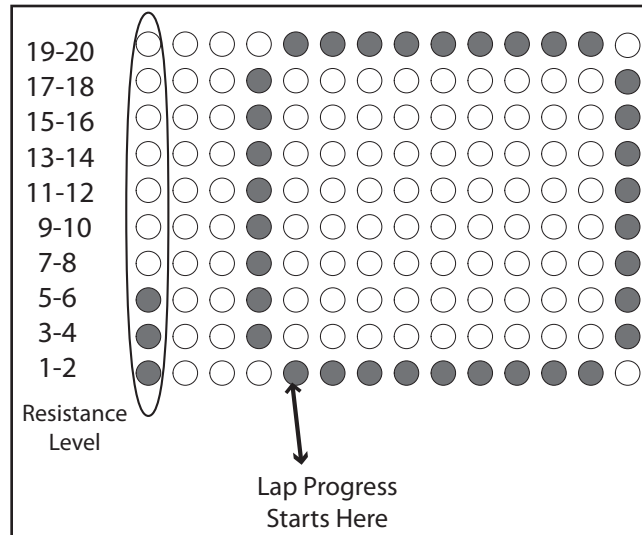

Lap Progress Display

URANCE®

by *Body-Solid*

Console Operation

QUICK START MODE

The Quick Start Program allows the user to quickly start using the machine without the use of preset programs. To enter *Quick Start (Manual) Mode*: Plug power adapter into wall outlet. Plug the adapter cord into the power input located on the lower front-left side of the unit. The MESSAGE WINDOW will display "PRESS PROGRAM KEY TO BEGIN". Press the START button instead. Start exercising. The Resistance Level can be changed at any time by pressing the MORE+/LESS- buttons. Time is set at 30 minutes. Weight is set at 150 lb.

MANUAL MODE

This program allows the user complete control over their workout. The user must make all resistance adjustments using the MORE+/LESS- buttons. Follow directions in the *Program Mode* section to enter and set values in *Manual Mode*.

PROGRAM MODE

There are six preset Programs. The preset programs are MOUNTAIN, HILL, RANDOM, INTERVAL SPEED TRAINING, INTERVAL, INTERVAL MOUNTAIN.

To enter *Program Mode*:

The MESSAGE WINDOW will display "PRESS PROGRAM KEY TO BEGIN". Press the PROGRAM button until desired program name shows in the MESSAGE WINDOW. The program profile will show in the PROFILE WINDOW. See the referenced charts for program names and resistance profiles. When the program you wish to use is displayed in the MESSAGE WINDOW, press the ENTER/SCAN button to confirm program selection. TIME is displayed in MESSAGE WINDOW. Use the MORE+/LESS- buttons to set the desired TIME. Press the ENTER/SCAN button to confirm the desired TIME setting. Default TIME is 30 minutes. TIME settings can range from 1 minute to 99 minutes.

NOTE: If the TIME entered is less than or equal to 14 minutes, each column in the program profile equals 1 minute.

If the TIME entered is greater than 14 minutes, each column equals TIME/14.

WEIGHT is shown in the MESSAGE WINDOW. Use the MORE+/LESS- buttons to set weight. Press the ENTER/SCAN button to confirm WEIGHT setting. The default WEIGHT is 150 pounds. WEIGHT settings can range from 70 Lb to 332 Lb.

AGE will show in MESSAGE WINDOW. Use the MORE+/LESS- buttons to set the AGE. Press ENTER/SCAN button to confirm AGE setting. The default AGE setting is 30. AGE settings can range from 1 to 99 years of age. Press the START button to exit *Program Mode* and begin the exercise session.

Console Operation

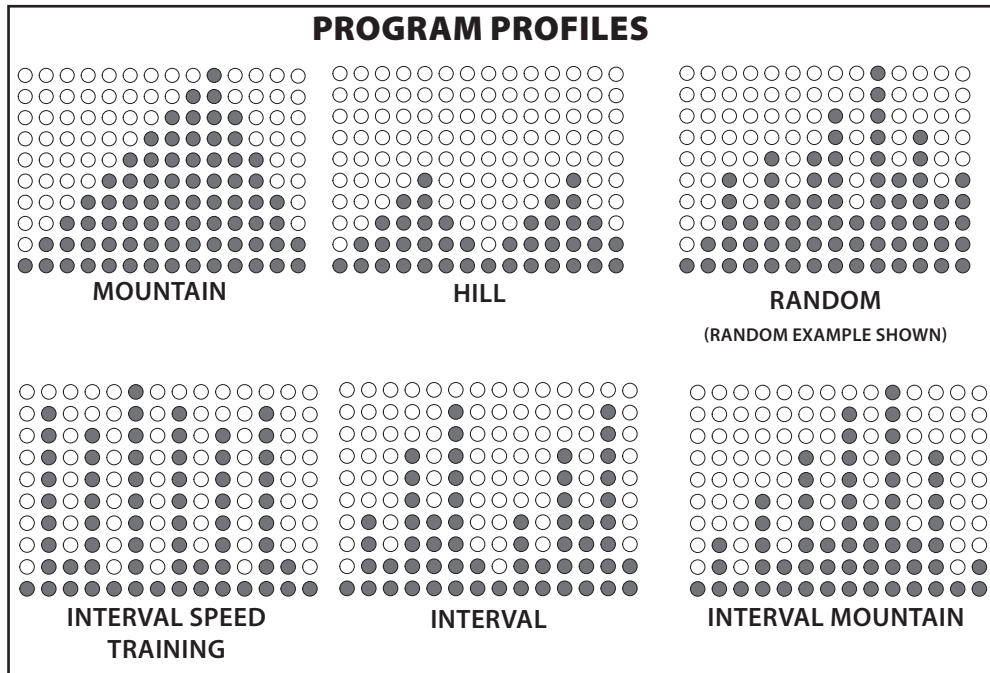

Program Profile Chart

MOUNTAIN

This program takes the user gradually up to a high resistance level, then brings the resistance level back down to the starting point. This program simulates what one might encounter on a true mountain course. This is a difficult program since higher tension levels are maintained for long periods of time.

HILL

This program takes the user through two hill profiles. Resistance changes are small during this program. This is a good program to get started with or for someone looking for a lower stress workout.

RANDOM

This program randomly generates a new program profile every time it is chosen. This allows you to keep the workouts fresh and motivating. When you scroll thru the programs to reach the RANDOM program, you will be able to see the program profile. If this profile is not to your liking, simply scroll thru the programs again and a new RANDOM program will be generated. The RANDOM program will be different every time you use it.

Console Operation

INTERVAL PROGRAMS OVERVIEW

These programs give users the best of both worlds. Lower intensity levels can provide effective fat burning while higher intensity levels can provide effective cardiovascular training. The E300 combines these benefits in three effective Interval programs.

INTERVAL

This program simulates interval training thru a series of two hill profiles.

INTERVAL MOUNTAIN

This program simulates interval training thru a difficult mountain profile.

INTERVAL SPEED TRAINING



This program simulates interval training with more extreme levels of high and low intensity levels.

USER PROFILES:



U1/U2

User Profiles U1 and U2 allow you to customize and save an exercise session.

Entering Data Into User Programs:

Scroll thru programs to U1 or U2. If no profile has been saved, the message window will scroll "EMPTY FILE PRESS START TO BUILD A NEW PROFILE". Press the **START**  button. You may make changes to the resistance level at any time during your exercise session. One you press the **PAUSE/RESET**  button and exit the program, the data is automatically saved.



Clearing A Saved User Program:

Press the **PROGRAM**  button to scroll to U1 or U2 program. Press the **ENTER/SCAN**  button to select the chosen program. Press and hold the **PAUSE/RESET**  button for 2 seconds. The console will beep twice to confirm that the selection was entered.

END

Console Operation

DURING OPERATION

The Console will display and update calculated workout data in each of the windows. The Console will continue to count down until TIME has reached 0:00. Use the **MORE** /LESS  buttons to adjust the resistance level at any time during your workout session. In the **PROFILE WINDOW**, the current column will be flashing.

The **PROFILE WINDOW** will toggle between the program profile and the track display. The program profile will actively display for 10 seconds while the track display will be active for 30 seconds.

URANCE®

by *Body-Solid*

Console Operation

STANDARD TO METRIC CONVERSION

The console allows the user to display the readout in either standard or metric units depending on the user's needs. To adjust the readout, press the **PAUSE/RESET** button for 2 seconds. The current readout, whether standard or metric, is displayed on the **MESSAGE WINDOW**. Use the **MORE** / **LESS** buttons to change the unit of measure. To confirm the selection, press the **ENTER/SCAN** button.

CONSOLE TESTING

Display Test

The display test allows the user the ability to test the **MESSAGE WINDOW** and the **PROFILE WINDOW** display for correct functionality. The display test is used perform a visual hardware check by allowing the **MESSAGE WINDOW** and the **PROFILE WINDOW** display the opportunity to display every LED in predetermined sequences. The **MESSAGE WINDOW** will display and cycle through the characters <0, 1, ... , 9> and <A, B, ... , F>. The **PROFILE WINDOW** will display and cycle through all the columns and rows illuminating an entire column or row with every cycle. To access the display test, first remove power and then reapply power to the elliptical. Once the elliptical is powered on, press the **MORE** and **LESS** buttons together and hold for 2 seconds.

Button Test

The button test allows the user to determine if the console's buttons are fully functional. Once the display test has been performed, press the **ENTER/SCAN** button to activate the button test. LEDs will be displayed next to the buttons as shown in the figure below.

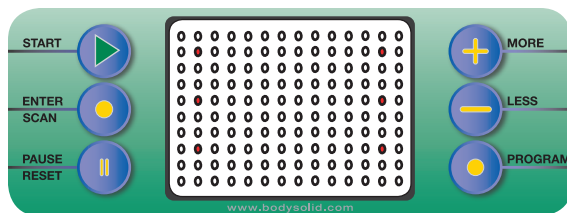

Button Test Display

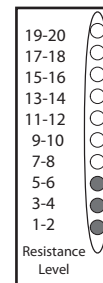

Resistance Level Chart

Pressing each button individually will turn off the adjacent LED signifying that each of the pressed buttons are active. When all the console buttons have been pressed, all the LEDs should be off in the **PROFILE WINDOW** display indicating that the buttons are working correctly. To exit this test once it has been completed, press the **PROGRAM** button.

Resistance Motor Test

Perform the resistance motor test to verify functionality of the resistance motor. Enter *Quick Start Mode* by pressing the **START** button to show the resistance level in the **PROFILE WINDOW**. The left column LEDs will illuminate as resistance is increased. See the Resistance Level Chart for reference.

Monitoring Your Heart Rate

To obtain the greatest cardiovascular benefits from your exercise workout, it is important to work within your target heart rate zone. The American Heart Association (AHA) defines this target as 60% -75% percent of the Maximum Heart Rate.

The Maximum Heart Rate may be roughly calculated by subtracting the user's age from 220.

The Maximum Heart Rate and aerobic capacity naturally decreases as the user ages. This may vary from one person to another, but use this number to find your approximate effective target zone. For example, the Maximum Heart Rate for an average 40 year-old is 180 bpm. The target heart rate zone is 60%-75% of 180 or 108-135 bpm. See the **FITNESS SAFETY** section.

Before beginning a workout, check the normal resting heart rate. The user can place their fingers lightly against the neck or wrist over the main artery. After finding the pulse, count the number of beats in 10 seconds. Multiply the number of beats by six to determine your pulse rate per minute. It is recommend to take a heart rate measurement at rest, after warming up, during the workout and two minutes into cooling down after the workout, to accurately track progress as it relates to better fitness.

During your first several months of exercising, the AHA recommends aiming for the lower part of the target heart rate zone - 60%, then gradually progressing up to 75%. According to the AHA, exercising above 75% of the Maximum Heart Rate may be too strenuous unless the user is in top physical condition. Exercising below 60% of the maximum will result in minimal cardiovascular conditioning.

CHECK YOUR PULSE RECOVERY RATE

If your pulse is over 100 bpm five minutes after stopping exercising, or if it's higher than normal the morning after exercising, the user's exertion may have been too strenuous for their current fitness level. Rest and reduce the intensity next time.

URANCE®

by *Body-Solid*

Stretching & Flexibility

Flexibility is an important component of physical fitness and needs to be addressed in a resistance training program. The two main purposes for stretching are injury prevention and a faster rate of recovery from exercise. Stretching should be performed in both the warm up and cool down phases of a training session. A good general guideline is that each workout session should be preceded by 5 to 15 minutes of general warm up, followed by 8 to 12 minutes of stretching, and concluded with 4 to 5 minutes of post-exercise stretching.

A regular stretching program will loosen muscle tissue, allowing an increased range of motion. This helps prevent micro-tears at the muscle-tendon junction. Almost 90% of all injuries from muscle strain occur at the muscle-tendon junction. Repeated injury at this junction can lead to a build-up of scar tissue, which impedes range of motion and adds stress to the joints.

Begin by stretching the major muscle groups first. Move in and out of your stretches with smooth, slow, controlled motion. Hold the stretch for at least 10 seconds when you feel you have reached your muscle's maximum distance. Do not use fast, hurried or reckless motions when stretching. Fast and bouncy motions will increase the risk of injury.

The most common and most popular type of stretching is the static stretching technique. This form of stretching involves voluntary, complete relaxation of the muscles while they are elongated. A static stretch is a constant, steady stretch in which the end position is held for 10 to 30 seconds. This technique is popular because it is easy to learn, effective, and accompanied by minimal soreness with the least risk of injury.

Ballistic stretching involves a bouncing or bobbing movement during the stretch. The final position in the movement is not held. Ballistic stretching is unpopular because of the increased amount of delayed muscle soreness and the possibility of injury during the stretching exercise. Ballistic stretching is not recommended.

A dynamic stretch involves flexibility during sport specific movements. Dynamic stretching is similar to ballistic stretching in that it utilizes movement, but dynamic stretching includes movements that may be specific to a sport or movement pattern. Dynamic stretching is most common among track and field athletes, but is also used in other sports, such as basketball and volleyball. An example of dynamic stretching would be a track sprinter performing high knees with an emphasis on knee height and arm action, not on horizontal speed.

The following pages show illustrations with descriptions of static stretching for warm up and post-exercise cool down. Remember... stretch your large muscle groups first and do all stretches in a smooth, slow, controlled manner.

END

Warm Up/Cool Down Exercises

UPPER BACK

Cross Arm in Front of Chest

MUSCLE(S) AFFECTED: *latissimus dorsi and teres major*

1. Stand or sit with the right arm slightly flexed (15° to 30°) and adducted across the chest.
2. Grasp the upper arm just above the elbow, placing the left hand on the posterior side of the upper arm.
3. Pull the right arm across the chest (toward the left) with the left hand; hold for 10 seconds.
4. Repeat with the left arm.



Stretching the upper back



Stretching the shoulders, chest and upper back

UPPER BACK

Arms Straight Up Above Head (Pillar)

MUSCLE(S) AFFECTED: *latissimus dorsi and wrist flexors*

1. Stand with arms in front of torso, fingers interlocked with palms facing each other.
2. Slowly straighten the arms above the head with palms up.
3. Continue to reach upward with hands and arms.
4. While continuing to reach upward, slowly reach slightly backward; hold for 10 seconds.

LOWER BACK

Spinal Twist (Pretzel)

MUSCLE(S) AFFECTED: *internal oblique, external oblique and spinal erectors*

1. Sitting with legs straight and upper body nearly vertical, place right foot on left side of left knee.
2. Place back of left elbow on right side of right knee, which is now bent.
3. Place right palm on floor 12 to 16 inches behind hips.
4. Push right knee to the left with left elbow while turning shoulders and head to the right as far as possible. Try to look behind the back. Hold for 10 seconds.
5. Repeat with left leg.



Stretching the lower back and sides

URANCE®

by Body-Solid

Warm Up/Cool Down Exercises

LOWER BACK

Semi-Leg Straddle

MUSCLE(S) AFFECTED: *spinal erectors*

1. Sitting, knees flexed 30 to 50 degrees, let the legs totally relax.
2. Point the knees outward; the lateral side of the knees may or may not touch the floor.
3. Lean forward from waist and reach forward with extended arms; hold position for 10 to 15 seconds.
4. Bending and relaxing legs decreases hamstring involvement and increases lower back stretch.



Stretching the lower back from a seated position



Rotational flexion of the neck

NECK

Look Right and Left

MUSCLE(S) AFFECTED: *sternocleidomastoid*

1. Stand or sit with head and neck upright.
2. Turn head to the right using a sub-maximal concentric contraction; hold for 10 seconds.
3. Turn head to the left using a sub-maximal concentric contraction; hold for 10 seconds.

NECK

Flexion and Extension

MUSCLE(S) AFFECTED: *sternocleidomastoid, suboccipitals and splenii*

1. Standing or sitting with head and neck upright, flex neck anteriorly (forward) by tucking chin in toward the chest; hold for 10 seconds.
2. If the chin touches the chest, try to touch lower on the chest with the chin.
3. Extend neck posteriorly (backward) by trying to touch the head to the trapezius; hold for 10 seconds.

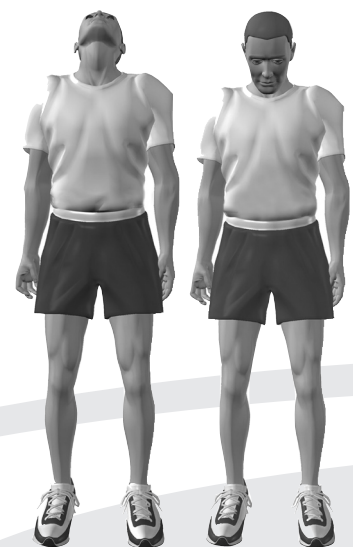

Neck Extension

Neck Flexion

Warm Up/Cool Down Exercises

CHEST/SHOULDER

Straight Arms Behind Back

MUSCLE(S) AFFECTED: *deltoids and pectoralis major*

1. Standing, place both arms behind back.
2. Interlock fingers with palms facing each other.
3. Straighten arms fully.
4. Slowly raise the straight arms; hold for 10 to 15 seconds.
5. Keep head upright and neck relaxed.



Stretching the sides, upper back and shoulders



Stretching shoulder joints and chest while standing

SIDES

Side Bend with Straight Arms

MUSCLE(S) AFFECTED: *external oblique, latissimus dorsi and serratus anterior*

1. Stand with feet 14 to 16 inches apart.
2. Interlace the fingers with palms facing each other.
3. Reach upward with straight arms.
4. Keeping arms straight, lean from waist to left side. Do not bend knees.
5. After moving as far as possible; hold for 10 seconds.
6. Repeat to the left side.

SIDES

Side Bend with Bent Arms

MUSCLE(S) AFFECTED: *external oblique, latissimus dorsi, serratus anterior and triceps*

1. Stand with feet 14 to 16 inches apart.
2. Flex right arm and raise elbow above head.
3. Reach the right hand down toward the left shoulder.
4. Grasp the right elbow (just above the elbow) with the left hand.
5. Pull the elbow behind head.
6. Keeping arm bent, lean from waist to left side.
7. Do not bend knees.
8. After moving as far as possible; hold for 10 to 15 seconds.
9. Repeat with the left arm.



Stretching the sides, triceps and upper back

URANCE®

by Body-Solid

Warm Up/Cool Down Exercises

ANTERIOR OF THIGH AND HIP FLEXOR

Side Quadricep Stretch

MUSCLE(S) AFFECTED: *quadriceps and iliopsoas*

1. Lie on left side with both legs straight.
2. Place left forearm flat on floor and upper arm perpendicular to floor.
3. Place left forearm at 45° angle with torso.
4. Flex right leg with heel of right foot moving toward buttocks.
5. Grasp front of ankle with right hand and pull toward buttocks.
WARNING: Do not pull on ankle so hard that pain or discomfort is felt in knee.
6. Move knee backward and slightly upward. The stretch occurs not so much from the excessive flexion of the knee but from moving the knee back and slightly up; hold for 10 to 15 seconds.
7. Repeat with the left leg.



Stretching the quadriceps
on side



Stretching the quadriceps
kneeling

ANTERIOR OF THIGH AND HIP FLEXOR

Kneeling Quadriceps Stretch

MUSCLE(S) AFFECTED: *quadriceps*

1. Kneel with the balls of the feet on the ground.
2. Keep hips straight (upper leg and torso should be in a straight line).
3. Place palms of hands on buttocks and push slightly forward.
4. With a straight body, lean slightly backward until developmental stretch is felt in quadriceps; hold for 10 to 15 seconds.



Stretching the hamstrings
with emphasis on insertion of
the hamstrings and calves.

POSTERIOR OF THIGH

Sitting Toe Touch

MUSCLE(S) AFFECTED: *hamstrings, spinal erectors and gastrocnemius*

1. Sit with the upper body nearly vertical and legs straight.
2. Lean forward from waist and grasp toes with each hand, slightly pull toes towards the upper body, and pull chest towards leg; hold for 10 seconds. (If you are very stiff, try to grasp the ankles.)
3. Release toes and relax foot.
4. Grasp ankles and continue to pull chest towards legs; hold for 10 seconds.
5. Still grasping the ankles, point away from body and continue to pull chest towards legs; hold for 10 seconds.



Stretching the hamstrings
with emphasis on the middle
portion.



Stretching the hamstrings
with emphasis on the
upper portion.

Warm Up/Cool Down Exercises

POSTERIOR OF THIGH

Semistraddle (Figure Four)

MUSCLE(S) AFFECTED: *gastrocnemius, hamstrings and spinal erectors*

1. Sit with the upper body nearly vertical and legs straight.
2. Place sole of left foot on left side of right knee. The lateral side of left leg should be resting on the floor.
3. Lean forward from the waist and grasp toes with right hand and slightly pull toes toward the upper body as the chest is also pulled toward right leg; hold for 10 seconds.
4. Release toes and relax foot.
5. Grasp ankle and continue to pull chest toward right leg; hold for 10 seconds.
6. Point toes away from body and continue to pull chest toward right leg; hold for 10 seconds.
7. Repeat with the left leg.



Stretching the hamstrings with emphasis on insertion of the hamstrings and calves



Stretching the hamstrings with emphasis on the middle portion



Stretching the hamstrings with emphasis on the upper portion



Stretching the hamstrings and groin with emphasis on insertion of the hamstrings and calves



Stretching the hamstrings and groin with emphasis on the middle portion



Stretching the hamstrings and groin with emphasis on the upper portion



Stretching the groin, low back and hamstrings

GROIN

Straddle (Spread Eagle)

MUSCLE(S) AFFECTED: *gastrocnemius, hamstrings, spinal erectors, adductors and sartorius*

1. Sit with the upper body nearly vertical and legs straight, and spread legs as far as possible.
2. With right hand, grasp toes of right foot and pull on toes slightly, while pulling chest toward right leg; hold for 10 seconds.
3. Release toes and relax foot.
4. Grasp ankle and continue to pull chest toward right leg; hold for 10 seconds.
5. Point toes away from body and continue to pull chest toward right leg; hold for 10 seconds.
6. Repeat process with the left leg.
7. Repeat process by grasping right toes with right hand and left toes with left hand. Move the torso forward and toward the ground.

UKRANCE®

by Body-Solid

Warm Up/Cool Down Exercises

GROIN

Butterfly

MUSCLE(S) AFFECTED: *adductors and sartorius*

1. Sitting with the upper body nearly vertical and legs straight, flex both knees as the soles of the feet come together.
2. Pull feet toward body.
3. Place hands on feet and elbows on legs.
4. Pull torso slightly forward as elbows push legs down; hold for 10 to 15 seconds.



Stretching the groin



Stretching calves without a step

POSTERIOR OF LOWER LEG

Bent-Over Toe Raise

MUSCLE(S) AFFECTED: *gastrocnemius and soleus*

1. Stand with heel of right foot 6 to 8 inches in front of left foot.
2. Flex right foot toward shin (dorsi-flexion) with heel in contact with floor.
3. Lean forward and try to touch right leg with chest while both legs are straight.
4. Continue to lean downward with upper body as the foot is dorsi-flexed near maximal toward the shin; hold for 10 to 15 seconds.
5. Repeat with the left leg.

POSTERIOR OF LOWER LEG

Step Stretch

MUSCLE(S) AFFECTED: *gastrocnemius and soleus;*
also, achilles tendon

1. Have ready a step or board 3 to 4 inches high.
2. Place balls of both feet on the step or board, 1 inch from its edge.
3. With straight legs, lower heels as far as possible; hold for 10 to 15 seconds.
4. To stretch achilles tendon, raise heels slightly. Slightly flex the knees and then lower the heels. This stretch will be felt in the achilles tendon; hold for 10 to 15 seconds.
5. For a more intense and individualized stretch, perform this stretch with one leg at a time.



Stretching the calves standing on a step



Preparing to stretch the achilles tendon by slightly bending the knee



Stretching the achilles tendon by lowering the heel

Warm Up/Cool Down Exercises

HIPS

Forward Lunge (Fencer)

MUSCLE(S) AFFECTED: *iliopsoas, rectus femoris*

1. Standing, take a long step forward (as with the lunge) with the right leg and flex the right knee until it is directly over the right foot.
2. Keep right foot flat on floor.
3. Keep back leg straight.
4. Keep back foot pointed in same direction as front foot; it is not necessary to have heel on floor.
5. Keep torso upright and rest hands on hips or front leg.
6. Slowly lower hips forward and downward; hold for 10 to 15 seconds.
7. Repeat with the left leg.



Stretching the hip flexors



Stretching the gluteals and hamstrings

HIPS

Supine Knee Flex

MUSCLE(S) AFFECTED: *hip extensors (gluteus maximus and hamstrings)*

1. Lie on back with legs straight.
2. Flex right leg and lift knee toward chest.
3. Place both hands below knee and continue to pull knee toward chest; hold for 10 to 15 seconds.
4. Repeat with left leg.

SHOULDER

Seated Lean-Back

MUSCLE(S) AFFECTED: *deltoids and pectoralis major*

1. Sitting with legs straight and arms extended, place palms on floor about 12 inches behind hips.
2. Point fingers away (backward) from body.
3. Slide hands backward and lean backward; hold for 10 seconds.



Stretching shoulder joints—sitting

URANCE®

by Body-Solid

Maintenance

Your Endurance® E300 Elliptical has been manufactured to withstand many hours of use with minimal maintenance. Here are some maintenance tips to keep your Endurance® E300 Elliptical running at its best.

IF SQUEAKING NOISE OCCURS

Your Endurance® E300 Elliptical may occasionally require Multi-Purpose Grease to be applied onto the underside of the foot pedal tube as shown. A small tube of Multi-Purpose Grease was included with your unit and can also be purchased at most stores. **DO NOT USE WD-40 OR SILICON SPRAY** since these compounds will increase squeaking noise over time.

Apply the Multi-Purpose Grease onto the bottom of both foot pedal tubes in the area that makes contact with the roller wheel as shown below. During normal usage (30 minutes of exercise per day), Multi-Purpose Grease is to be applied every 3 months or as needed.

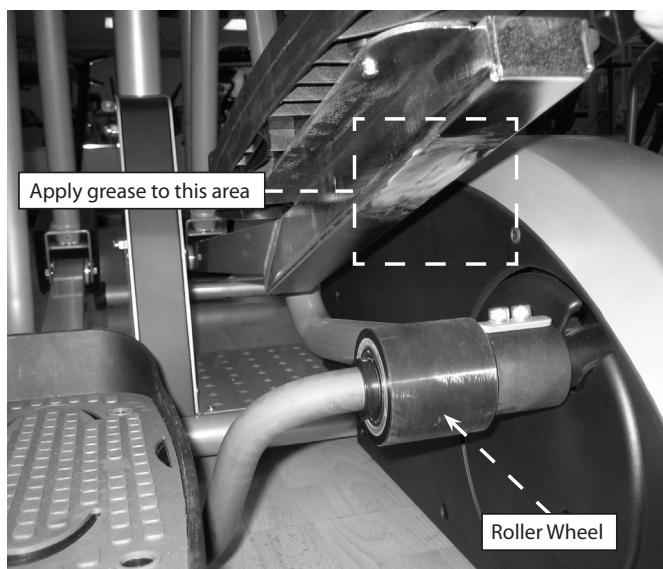

Correct Grease Application

CLEANING

Periodically wipe down your machine with mild, soapy water or a diluted general purpose non-abrasive household cleaner. Cleaner should never be applied directly to any part of the equipment. Instead, place the non-abrasive cleaning solution on a soft cloth and wipe down the unit. The elliptical should be wiped down to remove sweat after each use.

ERROR MESSAGES

The E300 console is equipped with auto-diagnostic technology if any fault to the machine is to occur in order to protect the safety of the user and the integrity and reliability of the machine. The E300 console automatically checks the brake motor status every time the unit is powered on. If the brake motor does not reply to the console's diagnostic call or does not move to its target position within 2 seconds, the console will display the error message 'MOTOR ERROR' immediately and disable button operation until power is reset. To clear the error message, unplug then plug in the unit.

If the console still displays the error message 'MOTOR ERROR', contact an authorized Endurance® dealer or an Endurance® factory-authorized service company or contact Endurance® Customer Tech Support at 1-800-556-3113.

Troubleshooting Guide

Symptom	Possible Cause	Solution
Console has no power.	DC adapter is not plugged into wall outlet?	Plug DC adapter into wall outlet.
	DC adapter is not plugged into the E300?	Plug DC adapter into the E300 power socket.
	Console cable is not connected?	Verify that the console cable is connected properly.
	The console is faulty?	Call the Endurance [®] service number.
Strides/Min or Speed shows 0	Computer isn't receiving a signal from the sensor?	Check that the sensor magnet is correctly fitted and passes in front of the sensor.
		Check that the gap between the sensor and the magnet is 3mm or less.
		Check that all the computer plugs and sockets are correctly and firmly connected.
	The sensor is faulty?	If all above checks are O.K., then replace sensor.
	The computer is faulty?	Call the Endurance [®] service number.
No HR signal or incorrect HR signal	Computer is receiving a faint or intermittent pulse signal.	Check that the pulse plugs firmly inserted into the sockets.
		Check to make sure that the batteries in the chest strap are installed correctly.
		Replace the chest strap batteries.
		Check to see if the receiver is properly installed.
		Check to see if the chest strap is being properly worn by the user - if skin is extremely dry, then moisten contact points on chest with water and try again.
		If the problem still exists then call the Endurance [®] service number.
Noise from motor	Symptoms include an unusually loud noise coming from the motor, which means the gears are not meshing correctly.	Try reversing the resistance and try again. If this fails, then replace the motor.

Any Questions?
Call the Customer Tech Hotline at:
1 (800) 556-3113

URANCE[®]

by Body-Solid

Endurance[®] E300 Parts List

Part #	Ref#	Quantity	Description
A	@2XSZ	2	MAINFRAME
E	@2XTF	1	HANDLE BAR
F	@2XTC	1	UPRIGHT
G	@2X7V	1	ARM (RIGHT)
H	@2X7U	1	ARM (LEFT)
K	@2XV4	1	MAINFRAME COVER
L	@2MJY	1	LEG
M	@2MK4	1	LEG
N	@2YAR	1	STRIDE FRAME (LEFT)
P	@2YAT	1	JUNCTION FRAME (RIGHT)
Q	@2YAU	1	JUNCTION FRAME (LEFT)
R	@2YAP	1	STRIDE FRAME (RIGHT)
1	01FD	1	LEFT STICKER
2	01FE	1	RIGHT STICKER
3	2XU2	1	STICKER
4	2Y7V	2	DO NOT STEP STICKER
5	2XVX	1	SHROUD STICKER (RIGHT)
6	2XVY	1	SHROUD STICKER (LEFT)
7	2XVS	1	SIDE SHROUD STICKER
8	2XTM	1	STRIDE STICKER
9	2XTY	1	SIDE STICKER
10	2XU1	1	SIDE STICKER
11	2YBR	1	STICKER (MADE IN TAIWAN)
12	2XVG	1	STICKER (SERIAL NUMBER)
13	2XS3	1	CONSOLE STICKER
14	2XV3	1	UPPER CONSOLE SHROUD
15	2XV5	1	LOWER CONSOLE SHROUD
16	2XK3	1	KNOB
17	2JC9	2	CARRY HANDLE
18	2XLF	1	KNOB
19	26LH	4	LEVELER
20	2XTZ	2	DISK COVER
21	@2XUT	1	TOP SHROUD (RIGHT/TOP)
22	2XTR	1	SIDE SHROUD (RIGHT/INNER)
23	2RY9	1	END CAP
23	2XTP	1	SIDE SHROUD (RIGHT/OUTER)
24	2NEK	1	END CAP STRAIN RELIEF 38x25mm
25	2XXM	2	PEDAL
26	2GQQ	1	GRIP, HANDRAIL SLEEVE
27	2Y09	2	BRACKET COVER
28	2XV6	2	STRIDE COVER (A)
29	2XU7	2	STRIDE COVER (B)
30	2XUG	2	BRACKET COVER
50	0K2W	3	SOCKET HEAD CAP SCREW M5x0.8-16

Endurance[®] E300 Parts List

Part #	Ref#	Quantity	Description	
51	2H66	1	HEX HEAD BOLT	M10*1.5-210
52	21NP	2	HEX HEAD BOLT (ZINC)	M12*1.75-110
53	2LXT	2	SOCKET HEAD BOLT CAP (BLACK)	M12X1.75-55
54	2J78	8	SOCKET HEAD CAP BOLT (ZINC w/PLASTIC)	M8x1.25-12
56	2Y04	2	TRUSS HEAD TAPPING SCREW (K-TYPE ZINC)	M5x16-8
57	0K94	18	TRUSS HEAD TAPPING SCREW	M5x12-16
58	2YGE	24	TRUSS HEAD TAPPING SCREW (K-TYPE BLACK)	M5X0.8-20
59	0K9C	4	THRUSS HEAD TAPPING SCREW	M3x24-8
60	0KA3	10	PAN HEAD TAPPING SCREW	M4x16-12
61	2XW7	4	SOCKET HEAD SCREW (ZINC w/PLASTIC)	M5x0.8-10
62	2N7U	2	SOCKET HEAD BOLT (ZINC w/PLASTIC)	M10x1.5-20
63	2DUD	6	TRUSS HEAD SCREW (ZINC)	M5x0.8-12
64	27JR	4	SOCKET SET SCREW	M5*0.8-6
65	2EZ1	2	TRUSS HEAD SCREW (BLACK)	M5x0.8-10
66	0K4R	2	TRUSS HEAD SCREW	M5x0.8-12
67	0KEQ	3	PAN HEAD SCREW (ZINC w/PLASTIC)	M5X0.8-12
68	2XUF	2	SOCKET HEAD CAP BOLT (ZINC)	M8x1.25-120
69	2XUH	2	SOCKET HEAD CAP BOLT (ZINC)	M8x1.25-75
70	2HMC	3	SOCKET TRUSS HEAD BOLT (ZINC w/PLASTIC)	M10X1.5-120
71	2XYT	2	CARRIAGE BOLT	M8x1.25-45
72	2D1X	3	PAN HEAD SCREW (ZINC w/PLASTIC)	M5x0.8-6
73	2P2Z	2	COMPRESSION SPRING	M1.2x7.1 T=4.2
74	0KDH	2	PAN HEAD SCREW	M5x0.8-8
75	0K7M	8	ROUND WASHER HD. SCREW	M6x1.0-18
76	0K3X	2	PAN HEAD SCREW & WASHER	M5x0.8-14
77	2HG6	6	SOCKET HEAD CAP BOLT (ZINC)	M8x1.25-16
78	21B8	2	HEX HEAD BOLT (ZINC)	M10*1.5-20
79	2P2E	1	BOLT	M6x1.0-16
80	143G		STOP PLATE	
81	21BA	2	HEX HEAD BOLT	M10*1.5-81.5
82	0J93	2	SPRING WASHER (BLACK) M10	
83	0J68	4	WASHER	OD=10 ID=5 T=1
84	22B4	2	WASHER	M10x35-2
85	0J4Z	4	FLAT WASHER	OD=20 ID=12 T=3
86	2XYS	2	FLAT WASHER	M8.4x15.5-0.8
87	2Y87(6)	6	FLAT WASHER (ZINC)	M10x20-1
88	0J69	6	FLAT WASHER	OD=13 ID=6 T=1
89	0GD9	2	WASHER	OD=30 ID=16 T=2.5
90	0J9C	2	SPRING WASHER (ZINC)	M10
91	018D	1	FLAT WASHER	M16x20-0.3
92	0KR0	2	NYLON LOCK NUT	M12*1.75 T12
93	0K2C	4	ALLEN HEAD SCREW	M8x1.25-16
94	20W4	2	NUT (BLACK)	M10x1.5 T=6
95	2Y85	4	CROWN NUT (ZINC)	M8x1.25 T=12.5
96	2HMB	3	CROWN NUT (ZINC)	M10x1.5 T=18
97	0KR4	2	NYLON LOCK NUT	M8x1.25 T=8

URANCE[®]

by Body-Solid

Endurance[®] E300 Parts List

Part #	Ref#	Quantity	Description	
98	22RR	2	NUT (ZINC)	M10*1.5,T8
99	21X8	3	SPACER	
100	01HR	1	TRANSFORMER	
101	01HU	1	POWER SOCKET	
102	01J8	1	REED SWITCH	
103	01HL	1	MOTOR	
104	2MXU	1	WIRE ASSEMBLY	1100MM 22AWG 7C
105	2MXV	1	WIRE ASSEMBLY	1300MM 22AWG 7C
106	2MY0	1	WIRE ASSEMBLY	350mm 22AWG 2C
107	2XYR	1	CHEST STRAP	
108	2QZ4	2	HR CONTACT	
109	2QZ2	2	HR CONTACT HOUSING (HANDLEBAR)	
110	21K5	1	MAGNET AND BRACKET	
111	2XZ0	1	UPPERBOARD	
112	2Y9X	1	OVERLAY	
113	2DB6	1	KEYPAD, START MEMBRANE	
114	2DB7	1	KEYPAD, +/- MEMBRANE	
115	2JZS	1	SPACER (CONSOLE)	
116	2152	1	WIRE ASSEMBLY (FOR WIRELESS HR)	
117	21PV	1	WIRELESS HR RECEIVER	
118	2X8S	1	CONTACT BOARD ASSEMBLY	
118	2XWJ	2	HR CONTACT WIRE	
119	@2XT9	1	WATER HOLDER ASSEMBLY	
120	2XS8	1	WARNING LABEL	
121	2XUK	2	TRANSPORT WHEEL	
122	2HJB	2	END CAP	
123	2XU7	1	SLIDER ASSEMBLY (R)	
124	2XU9	1	SLIDER ASSEMBLY (L)	
125	20N8	1	POP PIN, SEAT POST	
127	2GWU	1	MAG BRAKE CABLE	
128	2MT0	1	INDICATOR	
129	2KGJ	2	HAND CARD	
150	0JEG	1	C-RING	A-20
151	2KX8	2	BALL BEARING	6204ZZ
152	2H4J	1	RETAINING RING	
153	22LR	1	C-RING (BLACK)	A-16 T=1.2
154	@2H7B	1	SLEEVE ASSEMBLY	
155	2KX9	2	BALL BEARING	6005ZZ
156	2CU3	2	CENTER SHAFT WASHER	
157	2SDP	2	INNER BUSHING	
158	2CRJ	1	CRANK SHAFT	
159	2DUW	2	RETAINING RING	
160	2CU8	1	SHAFT WHEEL W/BALL BEARING, NO LIP	
161	2PJP	2	COLLAR	
162	2X72	1	ARBOR COLLAR (B)	
163	2X70	1	SHAFT SLEEVE	

END

Endurance[®] E300 Parts List

Part #	Ref#	Quantity	Description	
164	2UTT	1	BALL BEARING	2205
165	2NHZ	1	C-RING (BLACK)	B-52
166	2X71	1	ARBOR COLLAR (A)	
167	2PJQ	2	LINKING SEAT	
168	2HMD	3	SOCKET TRUSS HEAD BOLT (ZINC w/PLASTIC)	M10x1.5-80
169	0JEJ	2	C-RING	A-25
170	0KNM	4	NUT	M10X1.5 T=8
171	25VV	2	C-RING (BLACK)	B-47
172	2XXU	1	PLATE COVER	
173	2P30	2	FIXED COLUMN	
174	2P31	1	RUBBER PAD	
175	22B3	1	WASHER	OD=35 ID=26 T=0.8
176	2P36	1	SHAFT SLEEVE	
177	2KX7	2	BALL BEARING	6203ZZ
178	2GS1	1	PIN	
179	0JEE	2	C-RING	A-17
180	2GQN	1	MAGNETIC BRAKE ASSEMBLY	
181	2GQP	2	RETAINING CLIP	
182	21LG	2	COLLAR	
183	21AA	1	IDLER WHEEL BRACKET ASSEMBLY	
184	2CTQ	1	DRIVE WHEEL	
185	2N3N	2	CENTER SHAFT ASSEMBLY w/HOLE	
186	0KRK	18	U-TYPE NUT	M5-12mm
187	2CTS	1	DRIVE PULLEY	
188	2DAK	1	DRIVE BELT (POLY-V)	PJ450
189	@2XUV	1	TOP SHROUD (LEFT/TOP)	
190	157T	2	PAN HEAD SCREW	M3X0.5-35
191	0KNB	2	NUT (ZINC COATING)	M3x0.5 T=2.4
195	2Y87(3)	3		
196	0J4D	2	FLAT WASHER	M5x10-1
197	2XTT	1	SIDE SHROUD (LEFT/OUTER)	
198	2XTU	1	SIDE SHROUD (LEFT/INNER)	
200	0J3P	1	ALLEN WRENCH	
201	2CTD	4	SPECIAL NUT	
202	2CU7	4	SOCKET HEAD CAP BOLT	M12*1.75-30
203	2HNU	1	IDLER BELT TENSION ASSEMBLY	
204	2JAW	1	WRENCH	17MM
205	2JAX	1	CRESCENT WRENCH	17MM
206	2JAY	1	SCREWDRIVER	

URANCE[®]

by Body-Solid

TBA

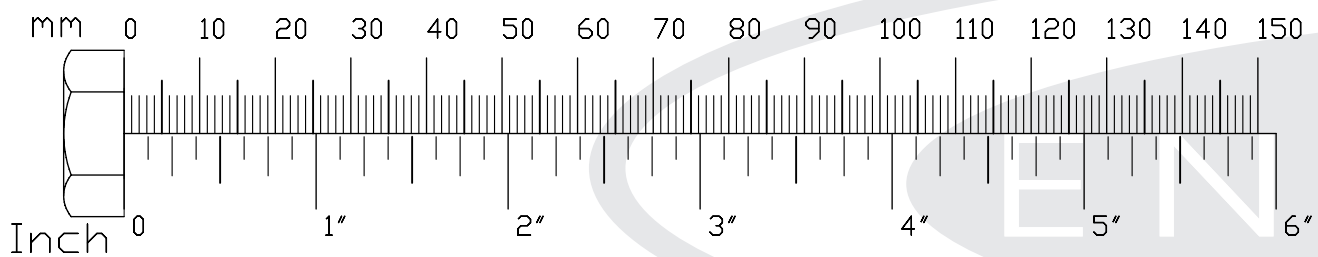

TBA

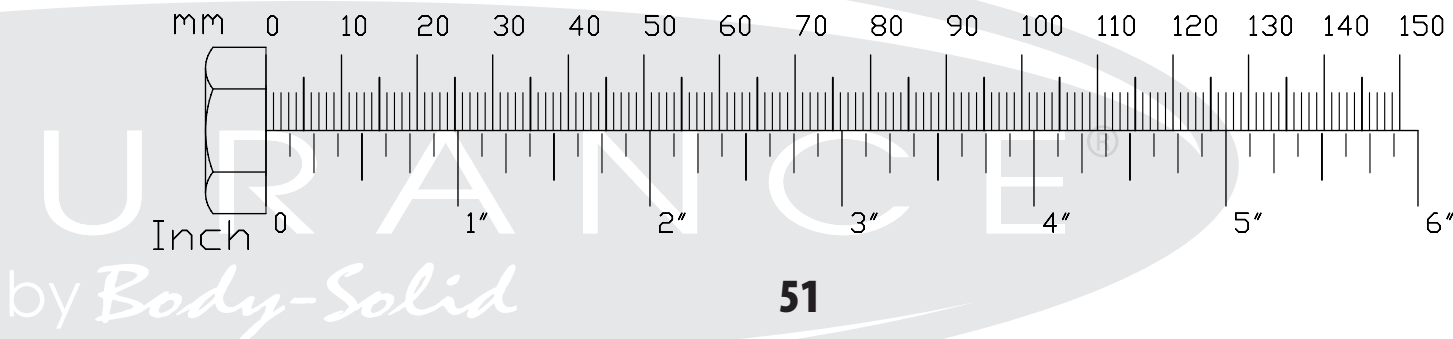

Endurance[®] E300

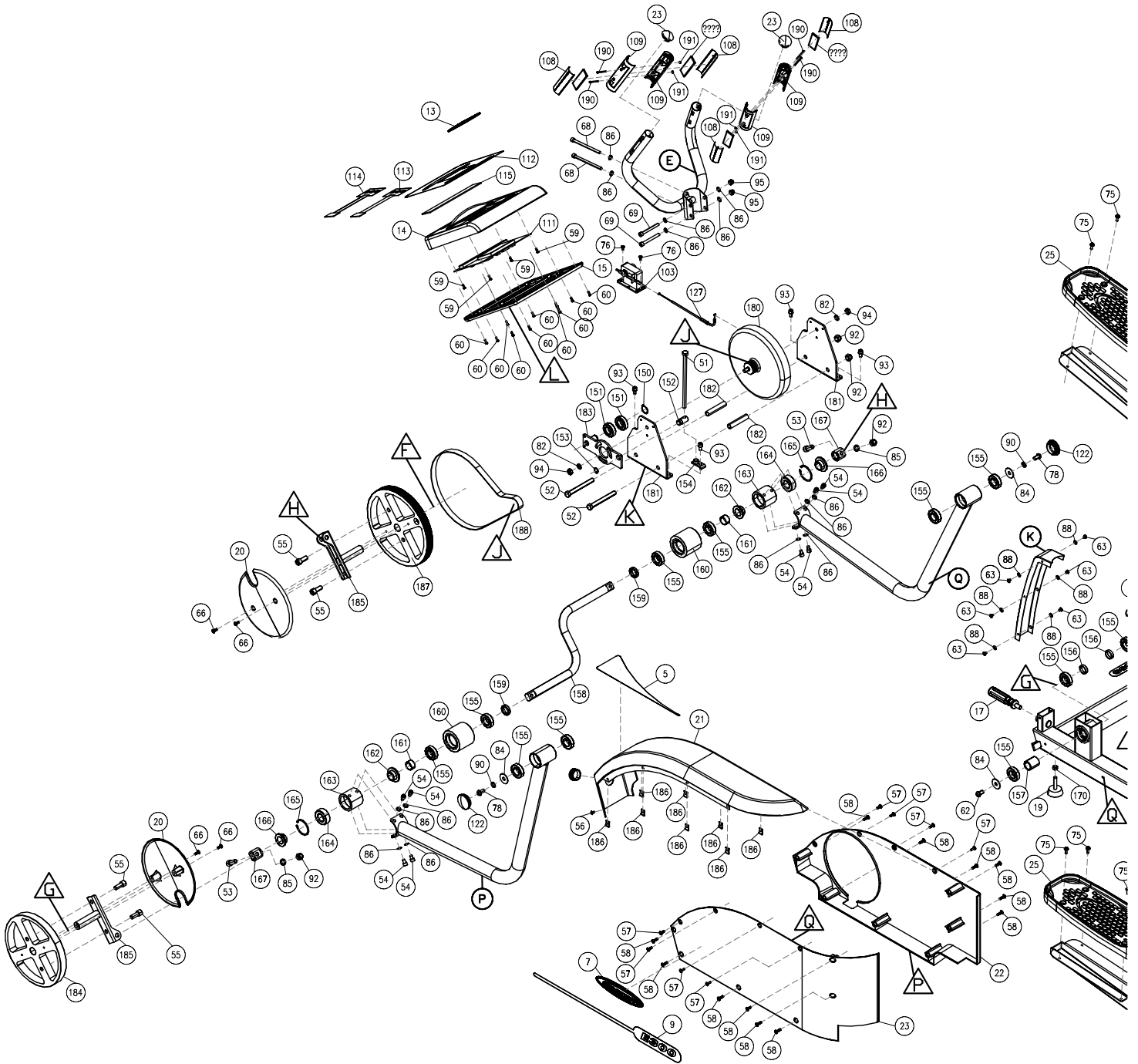

Exploded View

